



# THE DATASHEET OF NE555S-13



## Description

These devices are precision timing circuits capable of producing accurate time delays or oscillation. In the time-delay or monostable mode of operation, the timed interval is controlled by a single external resistor and capacitor network. In the astable mode of operation, the frequency and duty cycle can be controlled independently with two external resistors and a single external capacitor.

The threshold and trigger levels normally are two-thirds and one-third, respectively, of  $V_{CC}$ . These levels can be altered by use of the control-voltage terminal. When the trigger input falls below the trigger level, the flip-flop is set, and the output goes high. If the trigger input is above the trigger level and the threshold input is above the threshold level, the flip-flop is reset and the output is low. The reset (RESET) input can override all other inputs and can be used to initiate a new timing cycle. When RESET goes low, the flip-flop is reset, and the output goes low. When the output is low, a low-impedance path is provided between discharge (DISCH) and ground.

The output circuit is capable of sinking or sourcing current up to 200mA. Operation is specified for supplies of 5V to 15V. With a 5-V supply, output levels are compatible with TTL inputs.

## Pin Assignments

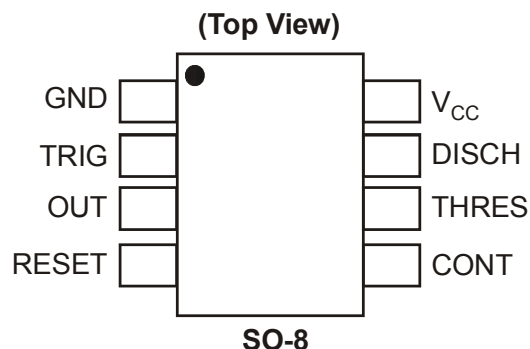

## Features

- Timing from microseconds to hours
- Astable or monostable operation
- Adjustable duty cycle
- TTL compatible output can source or sink up to 200mA
- **Totally Lead-Free & Fully RoHS Compliant (Notes 1 & 2)**
- **Halogen- and Antimony-Free. "Green" Device (Note 3)**
- **For automotive applications requiring specific change control (i.e. parts qualified to AEC-Q100/101/200, PPAP capable, and manufactured in IATF 16949 certified facilities), please [contact us](https://www.diodes.com/contact-us) or your local Diodes representative.**  
<https://www.diodes.com/quality/product-definitions/>

Notes:

1. No purposely added lead. Fully EU Directive 2002/95/EC (RoHS), 2011/65/EU (RoHS 2) & 2015/863/EU (RoHS 3) compliant.
2. See <https://www.diodes.com/quality/lead-free/> for more information about Diodes Incorporated's definitions of Halogen- and Antimony-free, "Green" and Lead-free.
3. Halogen- and Antimony-free "Green" products are defined as those which contain <900ppm bromine, <900ppm chlorine (<1500ppm total Br + Cl) and <1000ppm antimony compounds.

## Pin Descriptions

Pin Name	Pin Number	Description
GND	1	Ground
TRIG	2	Trigger set $1/3V_{CC}$
OUT	3	Timer output
RESET	4	Reset active low
CONT	5	External adjustment of internal threshold and trigger voltages
THRES	6	Threshold set to $2/3 V_{CC}$
DISCH	7	Low impedance discharge path
V <sub>CC</sub>	8	Chip supply voltage

## Functional Block Diagram

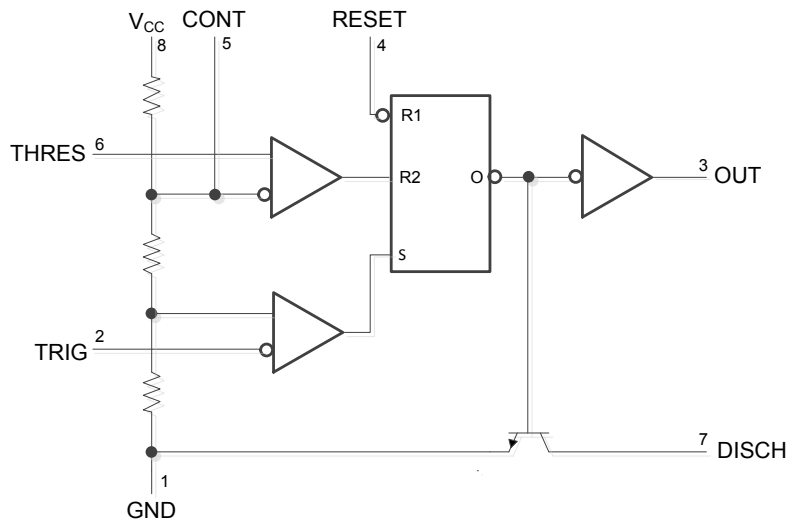

RESET can override TRIG, which can override THRESH

## Functional Table

RESET	Nominal Trigger Voltage	Threshold Voltage	Output	Discharge Switch
Low	Irrelevant	Irrelevant	Low	On
High	$<1/3V_{CC}$	Irrelevant	High	Off
High	$>1/3V_{CC}$	$>2/3V_{CC}$	Low	On
High	$>1/3V_{CC}$	$<2/3V_{CC}$	As previously established	

**Absolute Maximum Ratings** (Note 4) @  $T_A = 25^\circ\text{C}$  unless otherwise stated

Symbol	Parameter	Rating	Unit
$V_{CC}$	Supply voltage (Note 5)	18	V
$V_I$	Input voltage	CONT, RESET, THRES, TRIG	$V_{CC}$
$I_O$	Output current	$\pm 225$	mA
$\theta_{JA}$	Package thermal resistance Junction-to-Ambient (Note 6)	130	$^\circ\text{C/W}$
$\theta_{JC}$	Package thermal resistance Junction-to-Case (Note 7)	15	$^\circ\text{C/W}$
$T_J$	Junction temperature	150	$^\circ\text{C}$
$T_{STG}$	Storage temperature	-65 to 150	$^\circ\text{C}$

- Notes:
- Stresses beyond those listed under "absolute maximum ratings" may cause permanent damage to the device. These are stress ratings only. Functional operation of the device at these or any other conditions beyond those indicated under "recommended operating conditions" is not implied. Exposure to absolute-maximum-rated conditions for extended periods may affect device reliability.
  - All voltage values are with respect ground.
  - Maximum power dissipation is a function of  $T_J(\text{max})$ ,  $\theta_{JA}$ , and  $T_A$ . The maximum allowable power dissipation at any allowable ambient temperature is  $P_D = (T_J(\text{max}) - T_A)/\theta_{JA}$ . Operating at the absolute maximum  $T_J$  of  $150^\circ\text{C}$  can affect reliability.
  - Maximum power dissipation is a function of  $T_J(\text{max})$ ,  $\theta_{JC}$ , and  $T_A$ . The maximum allowable power dissipation at any allowable ambient temperature is  $P_D = (T_J(\text{max}) - T_C)/\theta_{JC}$ . Operating at the absolute maximum  $T_J$  of  $150^\circ\text{C}$  can affect reliability.

**Recommended Operating Conditions** ( $T_A = 25^\circ\text{C}$ )

Symbol	Parameter	Min	Max	Unit	
$V_{CC}$	Supply voltage	4.5	16	V	
$V_I$	Input voltage	—	$V_{CC}$	V	
$I_O$	Output current	—	$\pm 200$	mA	
$T_A$	Operating Ambient Temperature	NE555	0	70	$^\circ\text{C}$
		SA555	-40	85	
		NA555	-40	105	

**Electrical Characteristics** ( $V_{CC} = 5\text{V}$  to  $15\text{V}$ ,  $T_A = 25^\circ\text{C}$  unless otherwise stated)

Symbol	Parameter	Test conditions	Min	Typ.	Max	Unit
$V_{TH}$	Threshold voltage level	$V_{CC} = 15\text{V}$	8.8	10	11.2	V
		$V_{CC} = 5\text{V}$	2.4	3.3	4.2	
$I_{TH}$	Threshold current (Note 8)	—	—	30	250	nA
$V_{TR}$	Trigger voltage level	$V_{CC} = 15\text{V}$	4.5	5	5.6	V
		$V_{CC} = 5\text{V}$	1.1	1.67	2.2	
$I_{TR}$	Trigger current	TRIG at 0V	—	0.5	2	$\mu\text{A}$
$V_{RST}$	RESET voltage level	—	0.3	0.7	1	V
$I_{RST}$	RESET current	RESET at $V_{CC}$	—	0.1	0.4	mA
		RESET at 0V	—	-0.4	-1.5	
$I_{DIS}$	DISCH switch off-state current	—	—	20	100	nA
$V_{DIS}$	DISCH saturation voltage with output low (Note 9)	$V_{CC} = 15\text{V}$ , $I_{DIS} = 15\text{mA}$	—	180	480	mV
		$V_{CC} = 5\text{V}$ , $I_{DIS} = 4.5\text{mA}$	—	80	200	
$V_{CON}$	CONT voltage (open circuit)	$V_{CC} = 15\text{V}$	9	10	11	V
		$V_{CC} = 5\text{V}$	2.6	3.3	4	

- Notes:
- This parameter influences the maximum value of the timing resistors  $R_A$  and  $R_B$  in the circuit of Figure 12. For example, when  $V_{CC} = 5\text{V}$ , the maximum value is  $R = R_A + R_B \approx 3.4\text{M}\Omega$ , and for  $V_{CC} = 15\text{V}$ , the maximum value is  $10\text{M}\Omega$ .
  - No protection against excessive pin 7 current is necessary providing package dissipation rating is not exceeded

**Electrical Characteristics** ( $V_{CC} = 5V$  to  $15V$ ,  $T_A = 25^\circ C$  unless otherwise stated)

Symbol	Parameter	Test conditions	Min	Typ.	Max	Unit	
$V_{OL}$	Low level output voltage	$V_{CC} = 15V, I_{OL} = 10mA$	—	0.1	0.25	V	
		$V_{CC} = 15V, I_{OL} = 50mA$	—	0.4	0.75		
		$V_{CC} = 15V, I_{OL} = 100mA$	—	2	2.5		
		$V_{CC} = 15V, I_{OL} = 200mA$	—	2.5	—		
		$V_{CC} = 5V, I_{OL} = 5mA$	—	0.1	0.35		
		$V_{CC} = 5V, I_{OL} = 8mA$	—	0.15	0.4		
$V_{OH}$	High level output voltage	$V_{CC} = 15V, I_{OH} = -100mA$	12.75	13.3	—	V	
		$V_{CC} = 15V, I_{OH} = -200mA$	—	12.5	—		
		$V_{CC} = 5V, I_{OH} = -100mA$	2.75	3.3	—		
$I_{CC}$	Supply current	Output low, no load	$V_{CC} = 15V$	—	10	15	mA
			$V_{CC} = 5V$	—	3	6	
		Output high, no load	$V_{CC} = 15V$	—	9	13	
			$V_{CC} = 5V$	—	2	5	
$T_{ER}$	Initial error of timing interval (Note 10)	—	Each time, monostable (Note 11)	—	1	3	%
			Each time, astable (Note 12)	—	2.25	—	
$T_{TC}$	Temperature coefficient of timing interval	$T_A = \text{full range}$	Each time, monostable (Note 11)	—	50	—	ppm/ $^\circ C$
			Each time, astable (Note 12)	—	150	—	
$T_{VCC}$	Supply voltage sensitivity of timing interval	—	Each time, monostable (Note 11)	—	0.1	0.5	%V
			Each time, astable (Note 12)	—	0.3	—	
$T_{RI}$	Output pulse rise time	$C_L = 15pF$	—	—	300	ns	
$T_{FA}$	Output pulse fall time	$C_L = 15pF$	—	—	300	ns	

Notes: 10. Timing interval error is defined as the difference between the measured value and the average value of a random sample from each process run.  
11. Values specified are for a device in a monostable circuit similar to Figure 9, with the following component values:  $R_A = 2k\Omega$  to  $100k\Omega$ ,  $C = 0.1\mu F$ .  
12. Values specified are for a device in an astable circuit similar to Figure 12, with the following component values:  $R_A = 1k\Omega$  to  $100k\Omega$ ,  $C = 0.1\mu F$ .

**Typical Performance Characteristics**

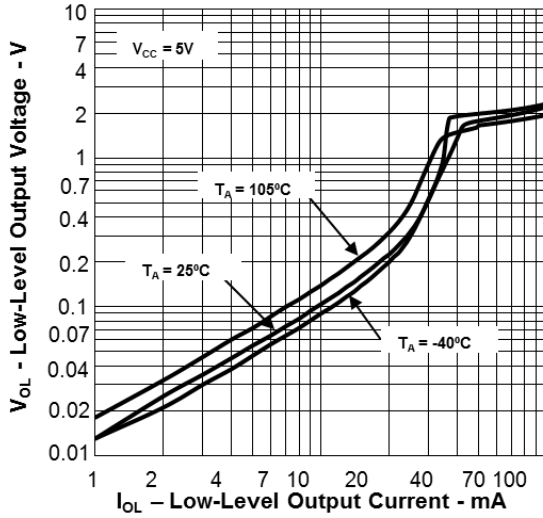

**Low Level Output Voltage vs.  
Low Level Output Current @  $V_{CC} = 5V$**

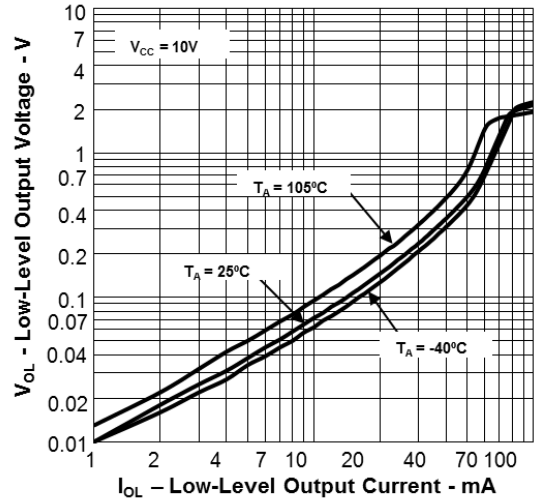

**Low Level Output Voltage vs.  
Low Level Output Current @  $V_{CC} = 10V$**

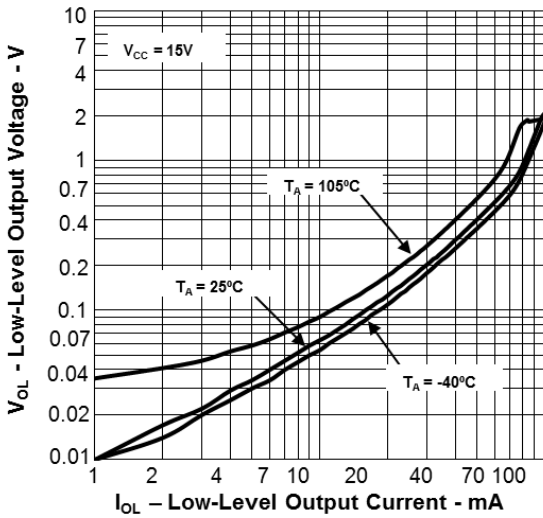

**Low Level Output Voltage vs.  
Low Level Output Current @  $V_{CC} = 15V$**

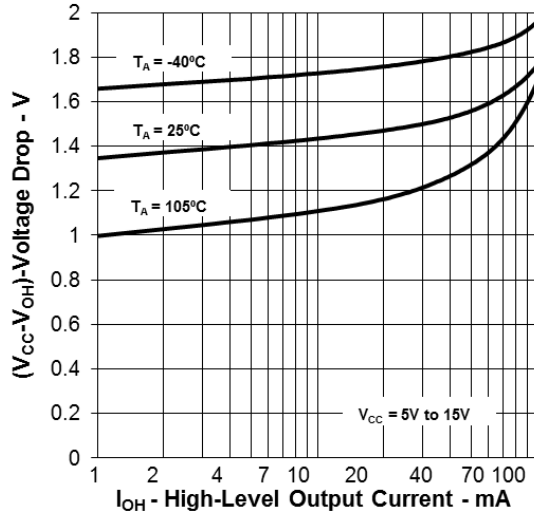

**Drop Between Supply Voltage and Output vs.  
High Level Output Current**

**Typical Performance Characteristics (cont.)**

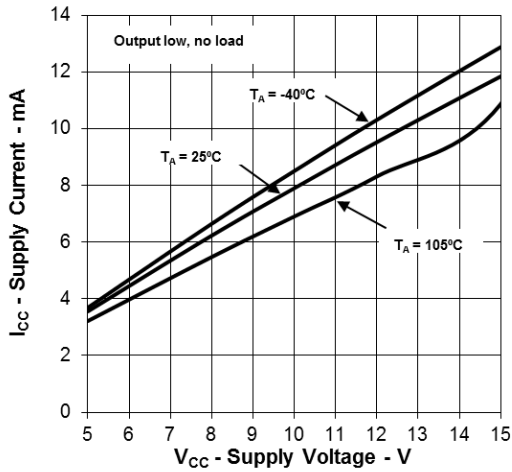

**Supply Current vs. Supply Voltage**

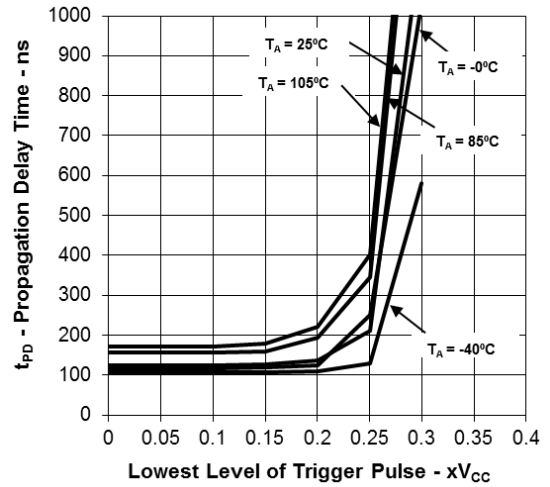

**Propagation Delay Time vs. Lowest Voltage Level of Trigger Pulse**

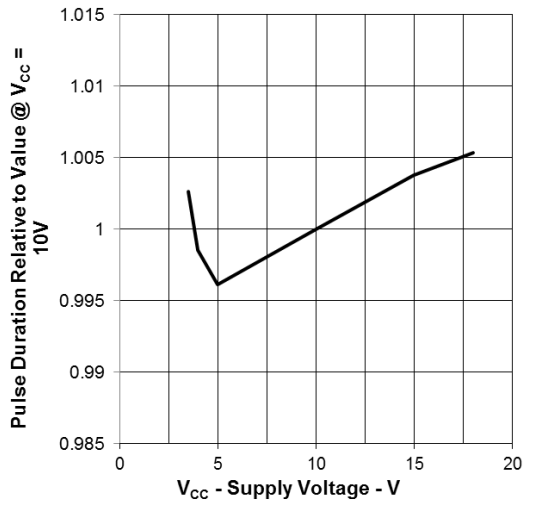

**Normalized Output Pulse Duration (Monostable Mode) vs. Supply Voltage**

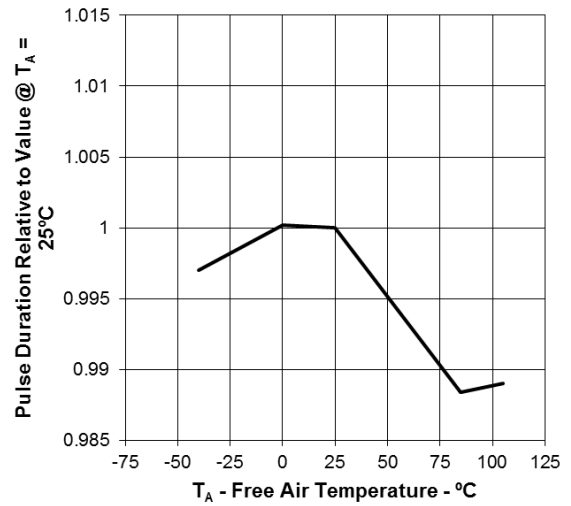

**Normalized Output Pulse Duration (Monostable Mode) vs. Free-Air Temperature**

## Typical Applications Characteristics

### Monostable Operation

For monostable operation, any of the '555 timers can be connected as shown in Figure 1. If the output is low, application of a negative-going pulse to the trigger (TRIG) sets the internal flip-flop and drives the output high. Capacitor C is then charged through  $R_A$  until the voltage across the capacitor reaches the threshold voltage of the threshold (THRES) input. If TRIG has returned to a high level, the output of the threshold comparator resets the internal flip-flop, drives the output low, and discharges C.

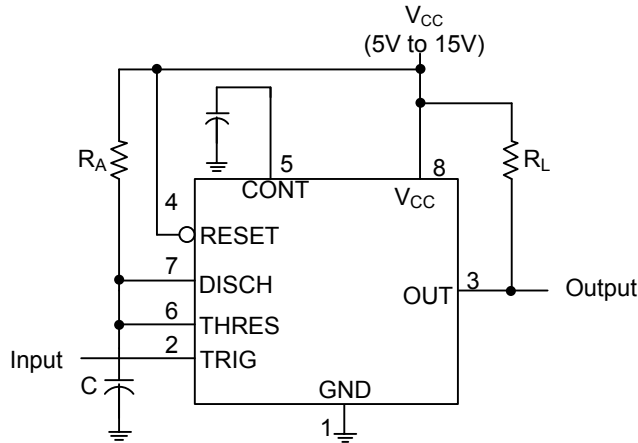

**Fig. 1 Monostable operation**

Monostable operation is initiated when TRIG voltage falls below the trigger threshold. Once initiated, the sequence ends only if TRIG is high for at least  $10\mu\text{s}$  before the end of the timing interval. When the trigger is grounded, the comparator storage time can be as long as  $10\mu\text{s}$ , which limits the minimum monostable pulse width to  $10\mu\text{s}$ . Because of the threshold level and saturation voltage of Q1, the output pulse duration is approximately  $t_w = 1.1R_A C$ . Figure 3 is a plot of the time constant for various values of  $R_A$  and C. The threshold levels and charge rates both are directly proportional to the supply voltage,  $V_{CC}$ . The timing interval is, therefore, independent of the supply voltage, so long as the supply voltage is constant during the time interval.

Applying a negative-going trigger pulse simultaneously to RESET and TRIG during the timing interval discharges C and reinitiates the cycle, commencing on the positive edge of the reset pulse. The output is held low as long as the reset pulse is low. To prevent false triggering, when RESET is not used, it should be connected to  $V_{CC}$ .

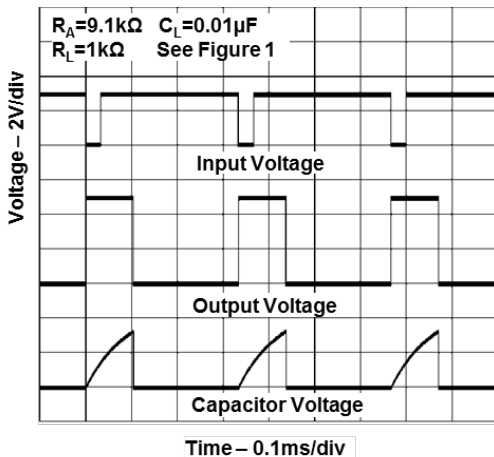

**Fig. 2 Typical Monostable Waveforms**

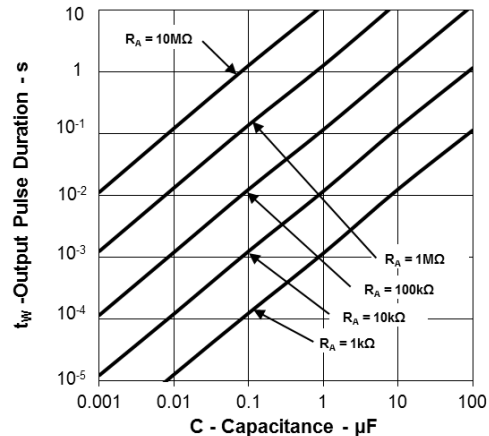

**Fig. 3 Output Pulse Duration vs. Capacitance**

**Typical Applications Characteristics** (cont.)

**Astable Operation**

As shown in Figure 4, adding a second resistor,  $R_B$ , to the circuit of Figure 1 and connecting the trigger input to the threshold input causes the timer to self-trigger and run as a multivibrator. The capacitor  $C$  charges through  $R_A$  and  $R_B$  and then discharges through  $R_B$ . Therefore, the duty cycle is controlled by the values of  $R_A$  and  $R_B$ .

This astable connection results in capacitor  $C$  charging and discharging between the threshold-voltage level ( $\approx 0.67V_{CC}$ ) and the trigger-voltage level ( $\approx 0.33V_{CC}$ ). As in the monostable circuit, charge and discharge times (and, therefore, the frequency and duty cycle) are independent of the supply voltage.

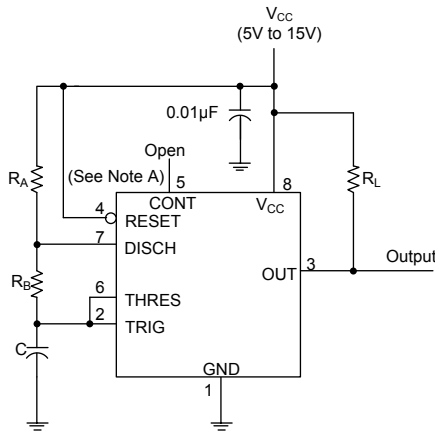

Decoupling CONT voltage to ground with a capacitor can improve operation. This should be evaluated for individual applications.

**Fig. 4 Circuit for Astable Operation**

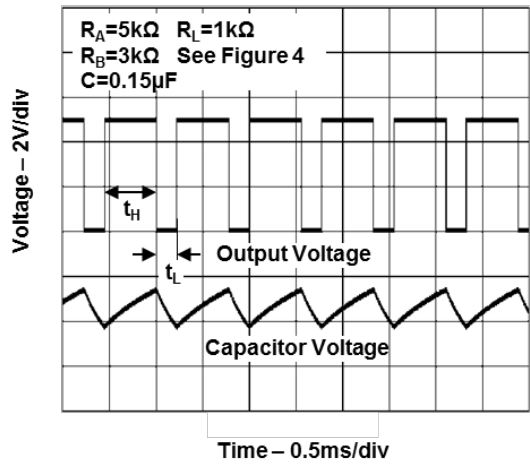

**Fig. 5 Typical Astable Waveforms**

Figure 5 shows typical waveforms generated during astable operation. The output high-level duration  $t_H$  and low-level duration  $t_L$  can be calculated as follows:

$$t_H = 0.693(R_A + R_B)C$$

$$t_L = 0.693(R_B)C$$

Other useful equations are:

$$\text{period} = t_H + t_L = 0.693(R_A + 2R_B)C$$

$$\text{frequency} = 1.44/(R_A + 2R_B)C$$

$$\text{output driver duty cycle} = t_L/(t_H + t_L) = R_B/(R_A + 2R_B)$$

$$\text{output waveform duty cycle} = t_H/(t_H + t_L) = 1 - R_B/(R_A + 2R_B)$$

$$\text{low to high ratio} = t_L/t_H = R_B/(R_A + R_B)$$

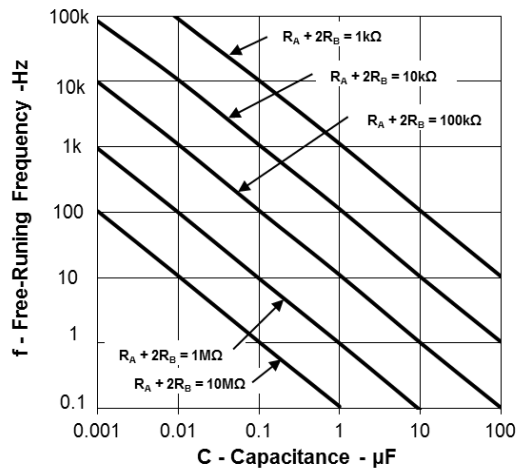

**Fig. 6 Free Running Frequency**



**Typical Applications Characteristics** (cont.)

**Pulse Width Modulation**

The operation of the timer can be modified by modulating the internal threshold and trigger voltages, which is accomplished by applying an external voltage (or current) to CONT. Figure 10 shows a circuit for pulse-width modulation. A continuous input pulse train triggers the monostable circuit, and a control signal modulates the threshold voltage. Figure 11 shows the resulting output pulse-width modulation. While a sine-wave modulation signal is shown, any wave shape could be used.

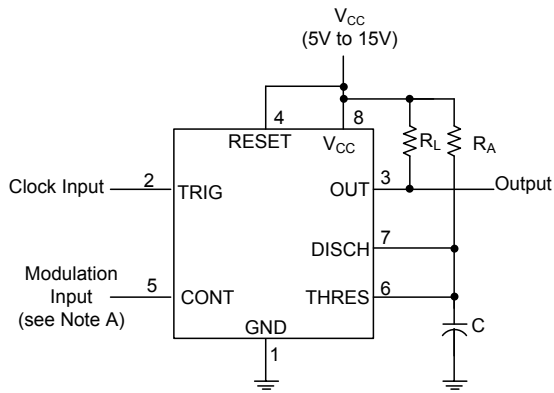

The modulating signal can be directly or capacitively coupled to CONT. For direct coupling, the effects of modulation source voltage and impedance on the bias of the timer should be considered.

**Fig. 10 Circuit for Pulse width modulation**

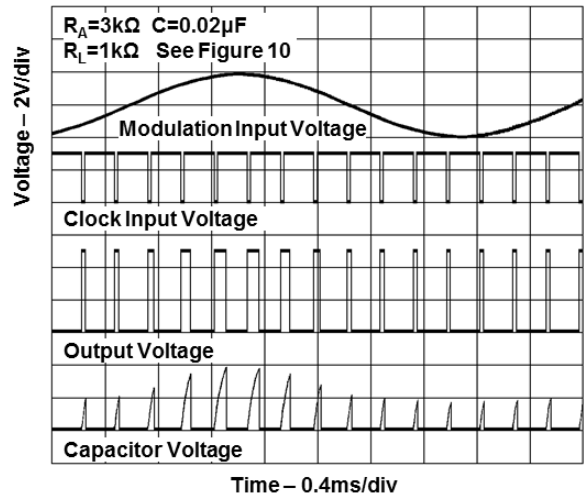

**Fig. 11 Pulse width modulation timing diagrams**

**Pulse Position Modulation**

As shown in Figure 12, any of these timers can be used as a pulse-position modulator. This application modulates the threshold voltage and, thereby, the time delay, of a free-running oscillator. Figure 13 shows a triangular-wave modulation signal for such a circuit; however, any wave shape could be used.

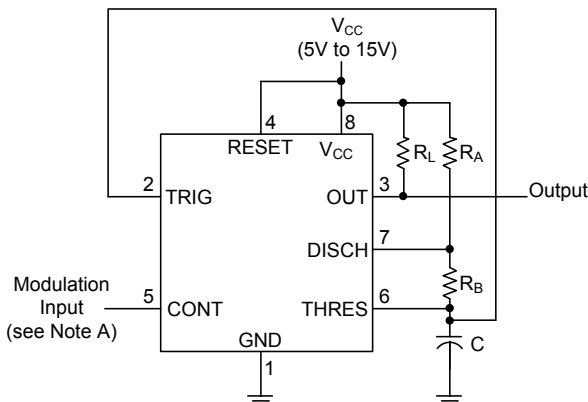

The modulating signal can be directly or capacitively coupled to CONT. For direct coupling, the effects of modulation source voltage and impedance on the bias of the timer should be considered.

**Fig. 12 Circuit for pulse position modulation**

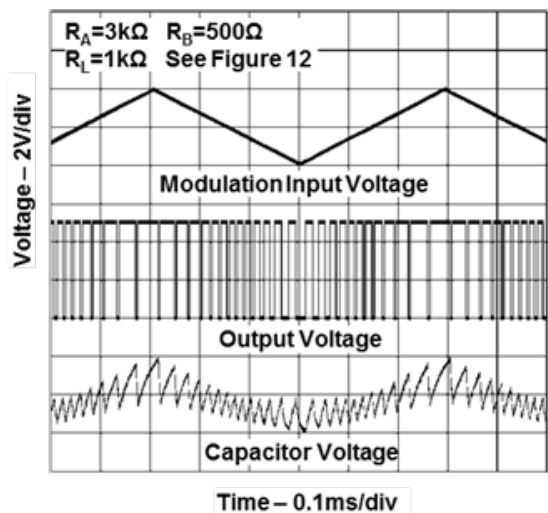
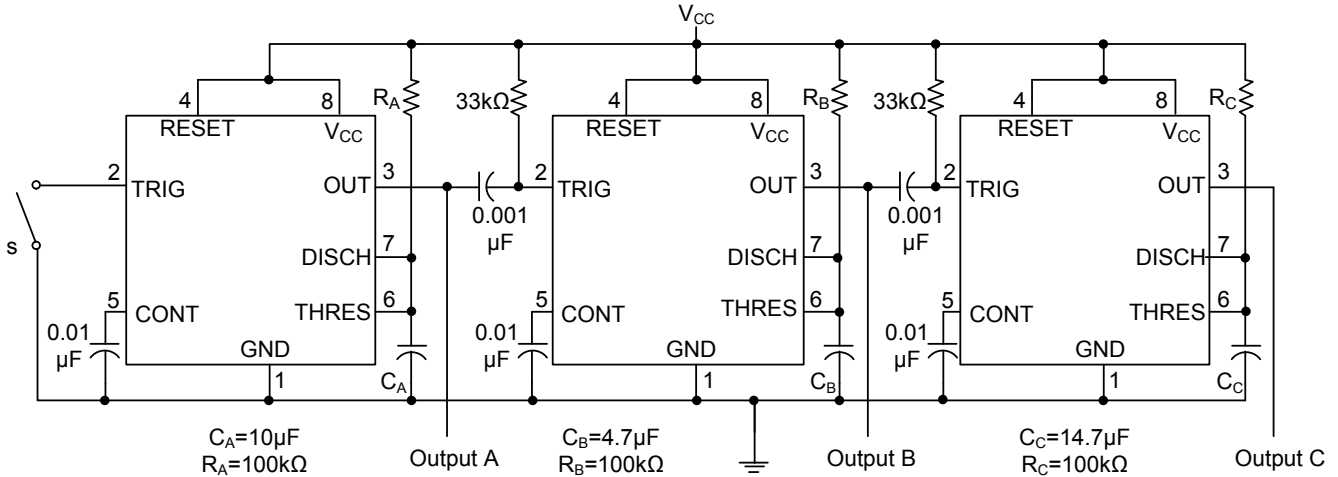

**Fig. 13 Pulse position modulation timing diagrams**

**Typical Applications Characteristics** (cont.)

**Sequential Timer**

Many applications, such as computers, require signals for initializing conditions during start-up. Other applications, such as test equipment, require activation of test signals in sequence. These timing circuits can be connected to provide such sequential control. The timers can be used in various combinations of astable or monostable circuit connections, with or without modulation, for extremely flexible waveform control. Figure 14 shows a sequencer circuit with possible applications in many systems, and Figure 15 shows the output waveforms.



Note A: S closes momentarily at t=0.

**Fig. 14 Circuit for Sequential Timer**

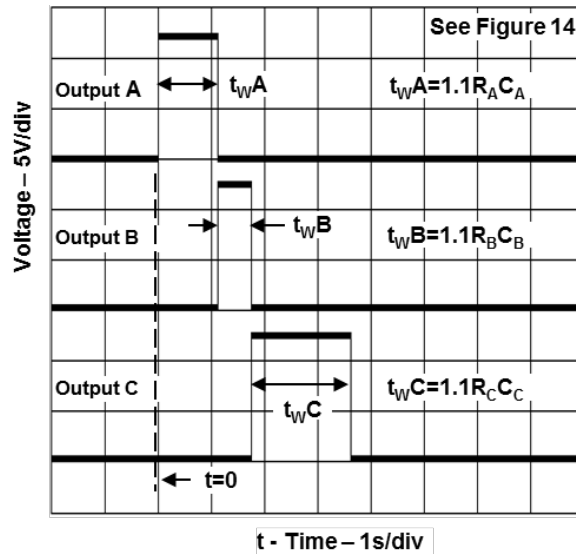

**Fig. 15 Sequential timer waveforms**

**Ordering Information**

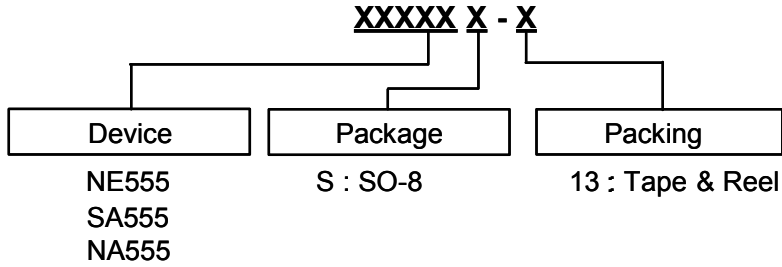

Device	Operating Temperature	Package Code	Packaging (Note 13)	13" Tape and Reel	
				Quantity	Part Number Suffix
NE555S-13	0 to 70°C	S	SO-8	2500/Tape & Reel	-13
SA555S-13	-40to 85°C	S	SO-8	2500/Tape & Reel	-13
NA555S-13	-40 to 105°C	S	SO-8	2500/Tape & Reel	-13

Notes: 13. For packaging details, go to our website at <https://www.diodes.com/design/support/packaging/diodes-packaging/>.

**Marking Information**

**SO-8**

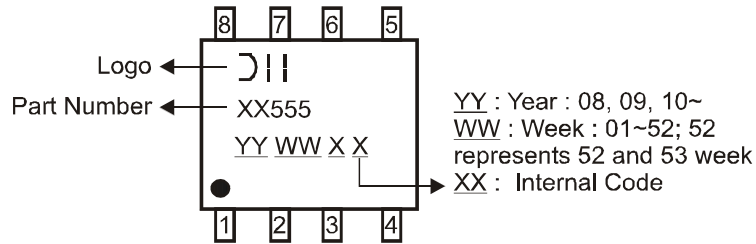

**Package Outline Dimensions (All Dimensions in mm)**

Please see <http://www.diodes.com/package-outlines.html> for the latest version.

SO-8

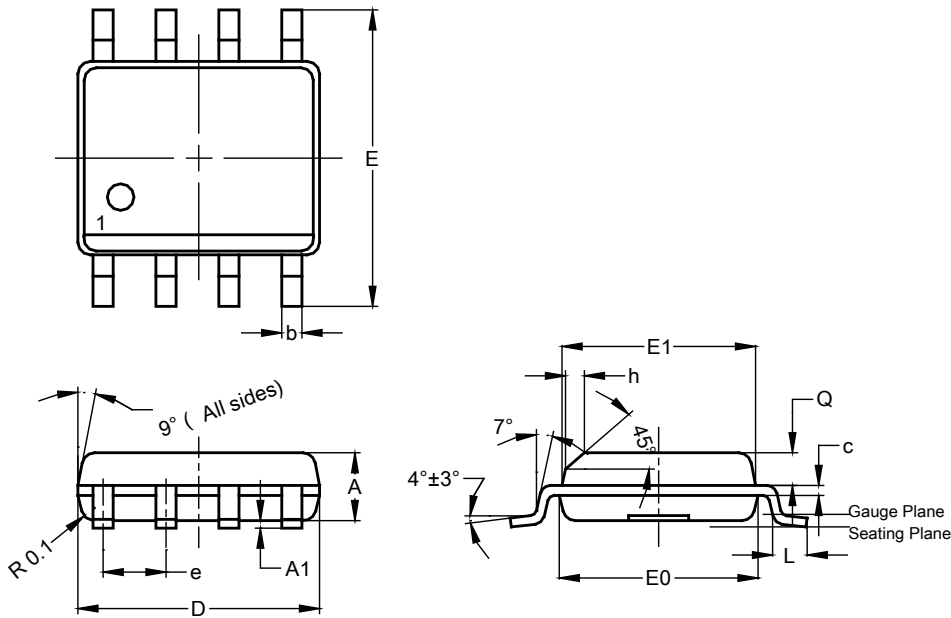

SO-8			
Dim	Min	Max	Typ
A	1.40	1.50	1.45
A1	0.10	0.20	0.15
b	0.30	0.50	0.40
c	0.15	0.25	0.20
D	4.85	4.95	4.90
E	5.90	6.10	6.00
E1	3.80	3.90	3.85
E0	3.85	3.95	3.90
e	--	--	1.27
h	-	--	0.35
L	0.62	0.82	0.72
Q	0.60	0.70	0.65
All Dimensions in mm			

**Suggested Pad Layout**

Please see <http://www.diodes.com/package-outlines.html> for the latest version.

SO-8

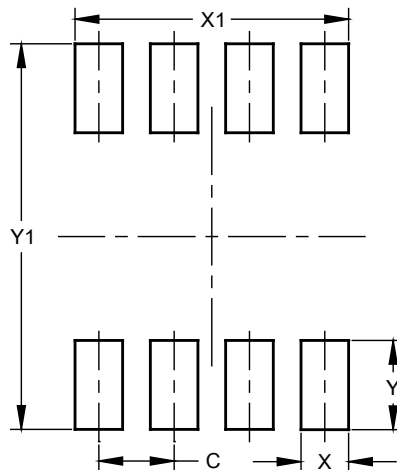

Dimensions	Value (in mm)
C	1.27
X	0.802
X1	4.612
Y	1.505
Y1	6.50

**IMPORTANT NOTICE**



1. DIODES INCORPORATED AND ITS SUBSIDIARIES (“DIODES”) MAKE NO WARRANTY OF ANY KIND, EXPRESS OR IMPLIED, WITH REGARDS TO ANY INFORMATION CONTAINED IN THIS DOCUMENT, INCLUDING, BUT NOT LIMITED TO, THE IMPLIED WARRANTIES OF MERCHANTABILITY, FITNESS FOR A PARTICULAR PURPOSE OR NON-INFRINGEMENT OF THIRD PARTY INTELLECTUAL PROPERTY RIGHTS (AND THEIR EQUIVALENTS UNDER THE LAWS OF ANY JURISDICTION).
2. The Information contained herein is for informational purpose only and is provided only to illustrate the operation of Diodes products described herein and application examples. Diodes does not assume any liability arising out of the application or use of this document or any product described herein. This document is intended for skilled and technically trained engineering customers and users who design with Diodes products. Diodes products may be used to facilitate safety-related applications; however, in all instances customers and users are responsible for (a) selecting the appropriate Diodes products for their applications, (b) evaluating the suitability of the Diodes products for their intended applications, (c) ensuring their applications, which incorporate Diodes products, comply the applicable legal and regulatory requirements as well as safety and functional-safety related standards, and (d) ensuring they design with appropriate safeguards (including testing, validation, quality control techniques, redundancy, malfunction prevention, and appropriate treatment for aging degradation) to minimize the risks associated with their applications.
3. Diodes assumes no liability for any application-related information, support, assistance or feedback that may be provided by Diodes from time to time. Any customer or user of this document or products described herein will assume all risks and liabilities associated with such use, and will hold Diodes and all companies whose products are represented herein or on Diodes' websites, harmless against all damages and liabilities.
4. Products described herein may be covered by one or more United States, international or foreign patents and pending patent applications. Product names and markings noted herein may also be covered by one or more United States, international or foreign trademarks and trademark applications. Diodes does not convey any license under any of its intellectual property rights or the rights of any third parties (including third parties whose products and services may be described in this document or on Diodes' website) under this document.
5. Diodes products are provided subject to Diodes' Standard Terms and Conditions of Sale (<https://www.diodes.com/about/company/terms-and-conditions/terms-and-conditions-of-sales/>) or other applicable terms. This document does not alter or expand the applicable warranties provided by Diodes. Diodes does not warrant or accept any liability whatsoever in respect of any products purchased through unauthorized sales channel.
6. Diodes products and technology may not be used for or incorporated into any products or systems whose manufacture, use or sale is prohibited under any applicable laws and regulations. Should customers or users use Diodes products in contravention of any applicable laws or regulations, or for any unintended or unauthorized application, customers and users will (a) be solely responsible for any damages, losses or penalties arising in connection therewith or as a result thereof, and (b) indemnify and hold Diodes and its representatives and agents harmless against any and all claims, damages, expenses, and attorney fees arising out of, directly or indirectly, any claim relating to any noncompliance with the applicable laws and regulations, as well as any unintended or unauthorized application.
7. While efforts have been made to ensure the information contained in this document is accurate, complete and current, it may contain technical inaccuracies, omissions and typographical errors. Diodes does not warrant that information contained in this document is error-free and Diodes is under no obligation to update or otherwise correct this information. Notwithstanding the foregoing, Diodes reserves the right to make modifications, enhancements, improvements, corrections or other changes without further notice to this document and any product described herein. This document is written in English but may be translated into multiple languages for reference. Only the English version of this document is the final and determinative format released by Diodes.
8. Any unauthorized copying, modification, distribution, transmission, display or other use of this document (or any portion hereof) is prohibited. Diodes assumes no responsibility for any losses incurred by the customers or users or any third parties arising from any such unauthorized use.

Copyright © 2021 Diodes Incorporated

[www.diodes.com](http://www.diodes.com)

## Looking for pricing, stock, or lifecycle information?

Click below to explore more details on WIN SOURCE:

-  [View NE555S-13 on WIN SOURCE](#)
-  [Diodes Incorporated Information](#)

## Optimize Your Supply Chain with WIN SOURCE Solutions

-  Global Sourcing Solution
-  Obsolete Management
-  Cost Control Management
-  Shortage Management
-  Alternative Solution
-  Excess Inventory Management