



**THE DATASHEET OF
NCS37012MNTWG**



NCS37012

Self Test Ground Fault Circuit Interrupter (GFCI)

Description

The NCS37012 is a fully UL943 compliant signal processor for GFCI applications with self test. The device integrates a flexible power supply (including both shunt and LDO regulators), differential fault, and grounded-neutral detection circuits. Proprietary impedance measurement and signal processing techniques are used to minimize the number of external components and improve performance. The device also includes a specialized DSP controller that offers best in class immunity to nuisance loads without the need for external analog filters. Self test is monitored every 17 minutes through an external current path and internally generated grounded neutral fault.

Features

- 6.0 V – 12 V Operation (120 – 480 V AC mains with the appropriate series impedance)
- –40 to 85°C
- Very Low Power Consumption: <15 mW @ 5 V
- 16 Pin QFN Package or 20 Pin TSSOP Package
- Single Current Transformer (CT) Detection of both Differential and Grounded–Neutral Faults
- Full Self Test and Trip Indicator Monitoring
- Self Syncing Internal Oscillator Adjusts to AC Mains Frequency to Guarantee Full Resolution on 50 and 60 Hz Distribution Systems
- Optimized Solenoid Deployment (coil is not energized near the AC mains zero crossings)
- Randomized Testing Sequence to Minimize Noise and Potential Interactions on the AC Mains
- >5 mA SCR Driver for use with High Igt SCR's for Improved Noise Immunity
- Superior Immunity to Nuisance Loads/Noise (up to 10 A) without Loss of Detection Capability or CT Saturation
- These Devices are Pb–Free, Halogen Free/BFR Free and are RoHS Compliant

Typical Applications

- Load Panel GFCI Breakers
- GFCI Receptacles
- In–line GFCI Circuits (power cords)



ON Semiconductor®

www.onsemi.com

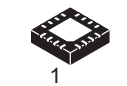

1
QFN16
MN SUFFIX
CASE 485G

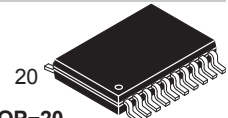

20
TSSOP–20
DA SUFFIX
CASE 948E

MARKING DIAGRAMS

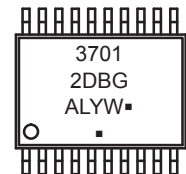
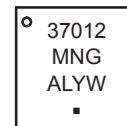

XXXXX = Specific Device Code
 A = Assembly Location
 L = Wafer Lot
 Y = Year
 W = Work Week
 ■ = Pb–Free Package

(Note: Microdot may be in either location)

PIN CONNECTIONS

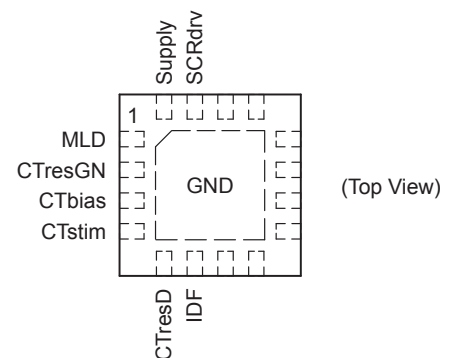

ORDERING INFORMATION

Device	Package	Shipping†
NCS37012MNTWG	QFN16 (Pb–Free)	3000 / Tape & Reel
NCS37012DBRG	TSSOP20 (Pb–Free)	2500 / Tape & Reel

†For information on tape and reel specifications, including part orientation and tape sizes, please refer to our Tape and Reel Packaging Specification Brochure, BRD8011/D.

NCS37012

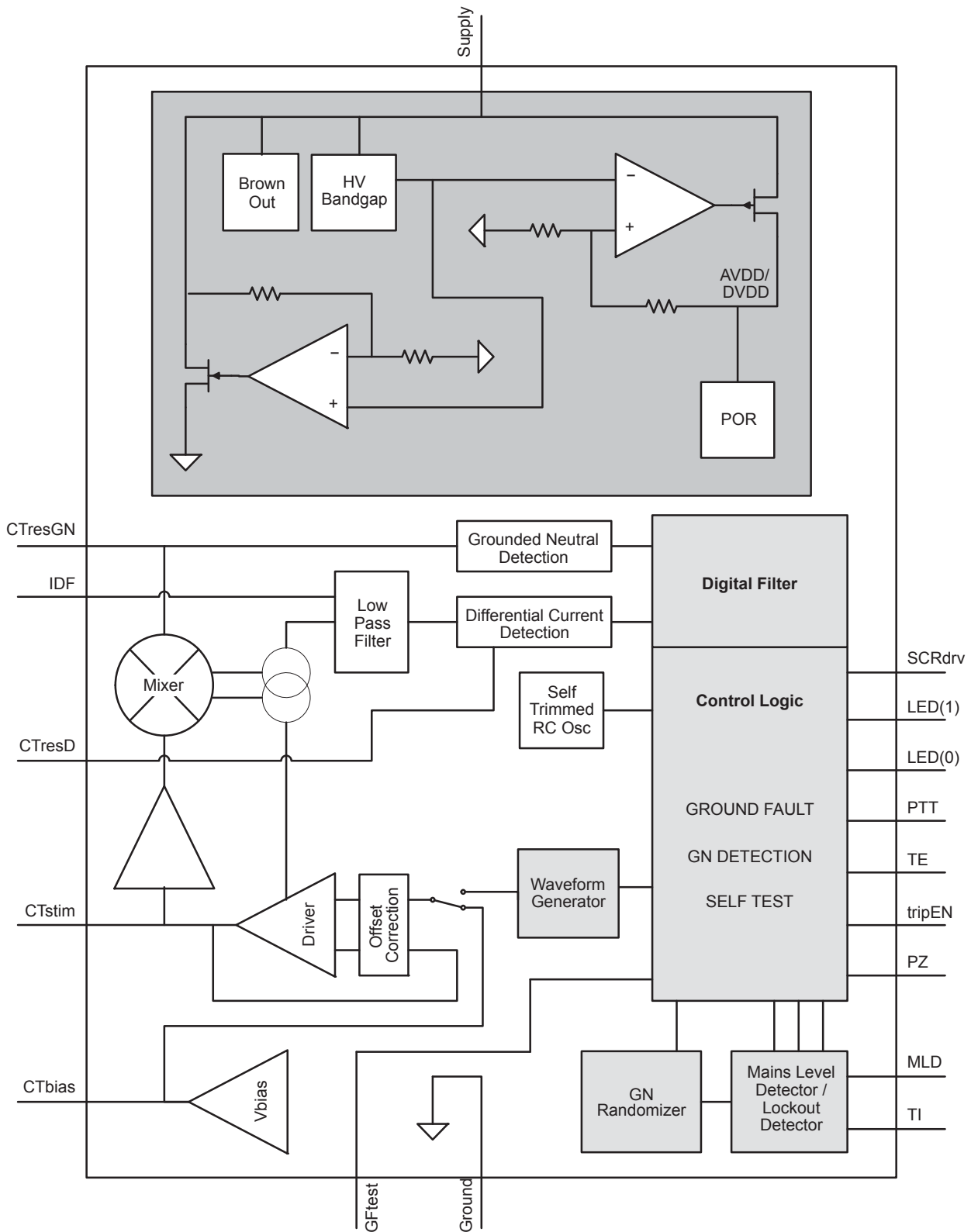

Figure 1. Simplified Block Diagram

NCS37012

Table 1. PIN FUNCTION DESCRIPTION – QFN

Pin #	Name	Pad Description
0	Ground	QFN center slug
1	MLD	Mains Level Detect (Zero Cross)
2	CTresGN	Determines IV converter gain for detection threshold / matched to CT turns ratio (Ground-Neutral)
3	CTbias	Direct connection to the CT
4	CTstim	Direct connection to the CT
5	CTresD	Determines IV converter gain for detection threshold / matched to CT turns ratio (Differential Current)
6	IDF	Front end noise filter capacitor
7	GFtest	Output to induce external differential current
8	TripEN	(H) Trip / (L) No Trip on Self Test Failure
9	PZ	Piezo output driver
10	NC	Tie to Ground or leave floating
11	PTT	Push to test input
12	TI	Tip indicator input
13	LED[0]	LED[0] output driver
14	LED[1]	LED[1] output driver
15	SCRdrv	Used to trigger the solenoid at a fault detection
16	Supply	Power supply

Table 2. PIN FUNCTION DESCRIPTION – TSSOP

Pin #	Name	Pad Description
1	CTstim	Differential and ground to neutral stimulus point for the current transformer
2	Ground	Ground connection for IC
3	CTresD	Determines IV converter gain for detection threshold / matched to CT turns ratio (Differential Current)
4	IDF	Determines corner frequency of the differential current path filter
5	GFtest	Output to induce external differential current
6	TripEN	(H) Trip / (L) No Trip on Self Test Failure
7	PZ	Piezo output driver
8	NC	Tie to Ground or leave floating
9	PTT	Push to test input
10	TI	Tip indicator input
11	Ground	Ground connection for IC
12	LED[0]	LED[0] output driver
13	LED[1]	LED[1] output driver
14	SCRdrv	Used to trigger the solenoid at a fault detection
15	DVDD	Internal digital 5 V regulated supply
16	AVDD	Internal analog 5 V regulated supply
17	Supply	12 V shunt regulated power supply
18	MLD	Mains Level Detect (Zero Cross) and AM slope detect (for oscillator sync/trim and AM init)
19	CTresGN	Determines IV converter gain for detection threshold / matched to CT turns ratio (Ground-Neutral)
20	CTbias	External 2 V bias for the current transformer

Table 3. ABSOLUTE MAXIMUM RATINGS

Rating	Symbol	Value	Unit
Supply Voltage Range	V _S	6.0 to 12 V	V
Input Voltage Range (Note 1)	V _{in}	-0.3 to 6.0	V
Output Voltage Range	V _{out}	-0.3 to 6.0 V or (V _{in} + 0.3), whichever is lower	V
Maximum Junction Temperature	T _{J(max)}	140	°C
Storage Temperature Range	T _{STG}	-65 to 150	°C
ESD Capability, Human Body Model (Note 2)	ESD _{HBM}	2	kV
ESD Capability, Machine Model (Note 2)	ESD _{MM}	200	V
Lead Temperature Soldering Reflow (SMD Styles Only), Pb-Free Versions (Note 3)	T _{SLD}	260	°C

Stresses exceeding those listed in the Maximum Ratings table may damage the device. If any of these limits are exceeded, device functionality should not be assumed, damage may occur and reliability may be affected.

1. Refer to ELECTRICAL CHARACTERISTICS and APPLICATION INFORMATION for Safe Operating Area.
2. This device series incorporates ESD protection and is tested by the following methods:
 ESD Human Body Model tested per AEC-Q100-002 (EIA/JESD22-A114)
 ESD Machine Model tested per AEC-Q100-003 (EIA/JESD22-A115)
 Latchup Current Maximum Rating: ≤ 150 mA per JEDEC standard: JESD78
3. For information, please refer to our Soldering and Mounting Techniques Reference Manual, SOLDERRM/D

Table 4. THERMAL CHARACTERISTICS

Rating	Symbol	Value	Unit
Thermal Characteristics, QFN16, 3x3.3 mm (Note 4) Thermal Resistance, Junction-to-Air (Note 5) Thermal Reference, Junction-to-Lead2 (Note 5)	R _{θJA} R _{ψJL}	TBD TBD	°C/W
Thermal Characteristics, TSSOP-20 (Note 4) Thermal Resistance, Junction-to-Air (Note 5)	R _{θJA}	TBD	°C/W

4. Refer to ELECTRICAL CHARACTERISTICS and APPLICATION INFORMATION for Safe Operating Area.
5. Values based on copper area of 645 mm² (or 1 in²) of 1 oz copper thickness and FR4 PCB substrate.

Table 5. OPERATING RANGES (Note 6)

Parameter	Conditions	Min	Typ	Max	Units
Operating Temperature		-40		85	C
IDD in typical power state			2.0		mA
Stimulus Generator Frequency	Tri-tone	3.1		3.4	kHz
SCR Trigger Current				8.0	mA
SCR Trigger output voltage	With 5 V supply	4.5		5.5	V
Fault Current Sensitivity	Programmable with CTresD	4.6	4.8	5.0	mA
Ground Fault Response Time	5 – 20 mA		150		ms
Ground Fault Response Time	20 – 40 mA		75		ms
Ground Fault Response Time	>40 mA		25		ms
Saturation Fault Response Time	>300 mA		1.4		ms
CT Turns Ratio		200		300	
Ground – Neutral Detection Threshold	Total series impedance (Rn and Rg)	3.0		6.0	Ω
Internal Oscillator Frequency			2.0		MHz
CT Stimulus Current	Internally limited			1.0	mA
CT Driver Closed Loop BW				500	kHz

Product parametric performance is indicated in the Electrical Characteristics for the listed test conditions, unless otherwise noted. Product performance may not be indicated by the Electrical Characteristics if operated under different conditions.

6. Refer to ELECTRICAL CHARACTERISTICS and APPLICATION INFORMATION for Safe Operating Area.

APPLICATIONS INFORMATION

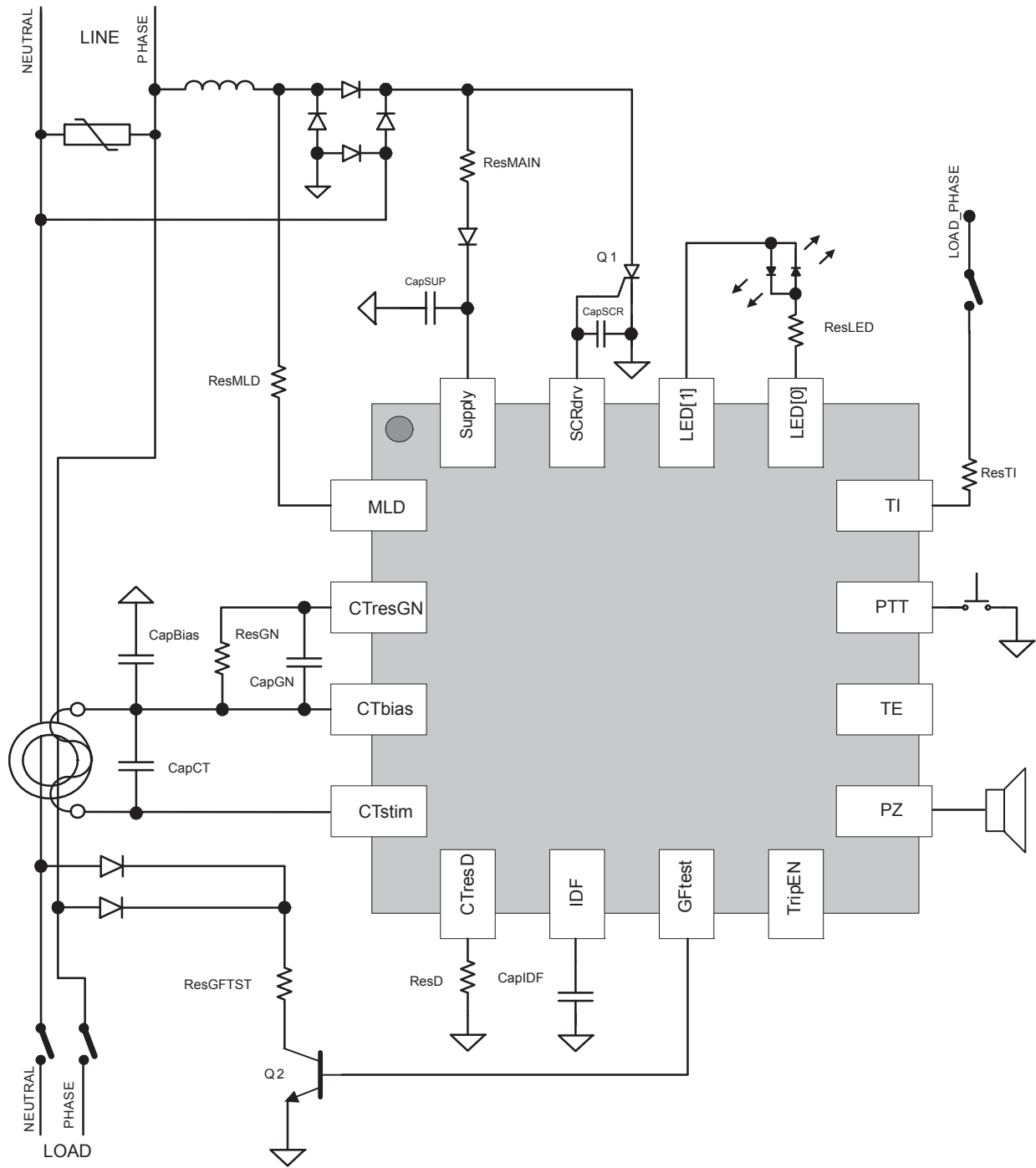

Figure 2. Typical Application Schematic

NCS37012

RECOMMENDED EXTERNAL COMPONENTS:

Component Type	Instance	Value	Note
SCR	Q1	-	ON-MCR08
Diode	Dx	-	ON-1N4007
NPN	Q2	-	MMBT6517LT1G
LED	Lx	-	LED pins drive opposite polarities
Capacitor	CapSUP	3.3 μ F	For a full bridge rectifier
Capacitor	CapGN	1-10 nF	Matched to current transformer
Capacitor	CapIDF	220 nF	Sets the differential corner frequency at 1 kHz
Capacitor	CapBias	10 nF	Filtering component for CTbias voltage
Capacitor	CapCT	2.2 - 10 nF	Filtering and resonant capacitor for CT
Capacitor	CapSCR	-	Filtering component
Resistor	ResD	40 - 80k	Matched to current transformer
Resistor	ResGN	100 - 400k	Matched to current transformer
Resistor	ResMLD	400 - 800k	Limiting resistor for the Mains Level Detector (MLD) input
Resistor	ResTI	400 - 800k	Limiting resistor for the Trip Indicator (TI) input
Resistor	ResMAIN	10k	For a full bridge rectifier
Resistor	ResGFTST	15k	Sets the external differential test current (8 mA)
Resistor	ResLED	1-5k	Sets the brightness of the LEDs
TVS	T1	-	~250-400V

LED AND SPEAKER FUNCTIONS

Device Function	Device State	LED[0]	LED[1]	Speaker
Normal	No Power / Line Load Reversed	OFF	LOW	OFF
	Power Up	HIGH for 500 ms	LOW	OFF
	Reset (Entered through PTT)	HIGH for 500 ms then LOW	HIGH	ON (250 ms)
	Tripped	LOW	HIGH	OFF
Abnormal	Self-Test Fails (Tripped)	(Blink) HIGH	LOW	OFF
	Self-Test Fails (Reset)	(Blink) HIGH	LOW	ON
	No Trip on Fault	(Blink) HIGH	LOW	ON

Filtering

The analog signal capture portion of the IC includes a single pole filter that can be set externally with Cidf. This provides an additional layer of protection against false tripping under steady state noise conditions. High frequency steady state noise is common with pumps, motors or other cyclic noise generators.

$Cidf = 220 \text{ nF} = 1 \text{ kHz low pass.}$

For additional filtering suggestions please contact ON Semiconductor.

Setting Trip Sensitivity

The CTresD resistor sets the threshold for the differential current fault levels. Increasing CTresD causes the fault

levels to trip at lower differential currents. CT efficiency at 60 Hz must be considered.

$CTresD = 400 * \#Turns$ – Subject to CT efficiency at 60 Hz

The CTresGN resistor sets the threshold for ground to neutral fault detection. The Rt parameter is the desired ground to neutral resistance trip level. Higher CTresGN values will cause the part to trip at higher ground to neutral impedances.

$CTresGN = \#Turns^2 \times Rt/2$ – Subject to CT efficiency from 3 kHz to 4 kHz

Setting Grounded – Neutral Response Time

C_{gn} is used to define the response time of the grounded-neutral detection circuit. The analog portion converts the impedance into a DC voltage and a high frequency (aliased) component. The capacitor is used to remove the high frequency component leaving just the DC representation of the impedance.

$$CT_{capGN} = 1.8E-4 / CT_{resGN}$$

Self Test

Automatic self test will occur every 17 minutes. If a failure is observed it will be retested every second until it passes. If it fails 8 successive tests then the GFCI will indicate that it has failed self test. See the LED and speaker functions table to see the different self test indicators. If TripEN is asserted high the GFCI unit will trip.

Differential ground fault test – tests the CT and the internal differential detection signal path by asserting the GFtest output high for 2 half cycles. The test will pass if a 6-8 mA differential current is enabled during these two half waves. Greater than 20 mA current during this test will cause a fault to be detected.

Ground neutral fault test – tests the internal ground neutral stimulus and detection paths by enabling an internal 50k resistor between the CTstim and CTbias pins. If the resistor and capacitor on CTresGN are connected this will pass the GN self test.

PTT

When the PTT input pin is de-asserted for greater than 80 ms a self test will be performed. If this test is successful the SCR will be fired which will trip the GFCI unit. If the test is unsuccessful the LED[0] pin will flash indicating a failure.

NCS37012

PACKAGE DIMENSIONS

TSSOP-20
CASE 948E-02
ISSUE C

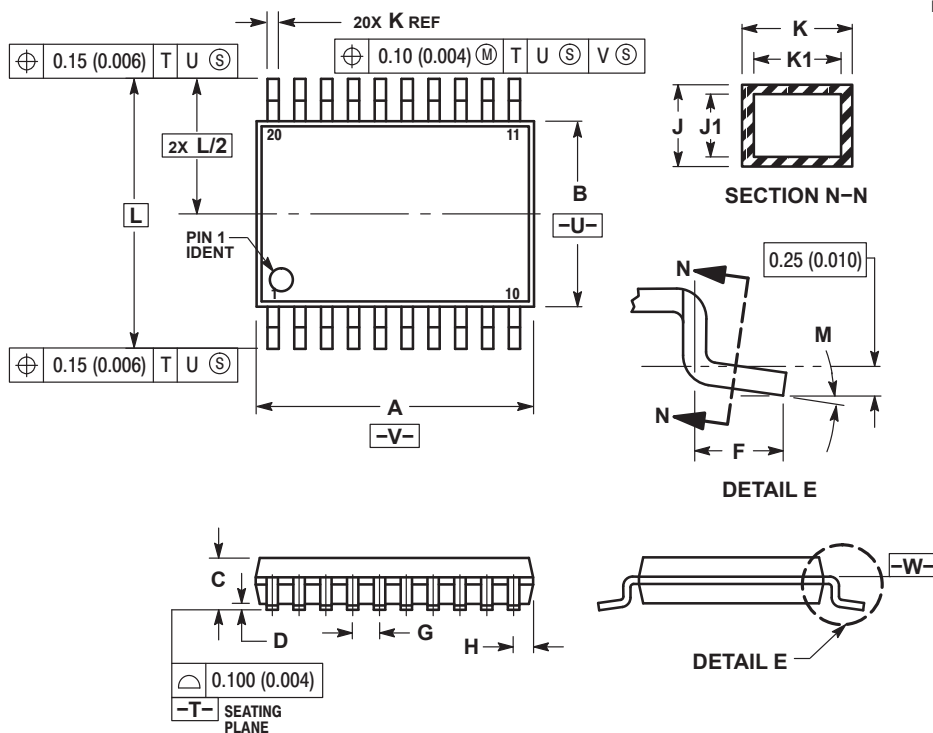

NOTES:

1. DIMENSIONING AND TOLERANCING PER ANSI Y14.5M, 1982.
2. CONTROLLING DIMENSION: MILLIMETER.
3. DIMENSION A DOES NOT INCLUDE MOLD FLASH, PROTRUSIONS OR GATE BURRS. MOLD FLASH OR GATE BURRS SHALL NOT EXCEED 0.15 (0.006) PER SIDE.
4. DIMENSION B DOES NOT INCLUDE INTERLEAD FLASH OR PROTRUSION. INTERLEAD FLASH OR PROTRUSION SHALL NOT EXCEED 0.25 (0.010) PER SIDE.
5. DIMENSION K DOES NOT INCLUDE DAMBAR PROTRUSION. ALLOWABLE DAMBAR PROTRUSION SHALL BE 0.08 (0.003) TOTAL IN EXCESS OF THE K DIMENSION AT MAXIMUM MATERIAL CONDITION.
6. TERMINAL NUMBERS ARE SHOWN FOR REFERENCE ONLY.
7. DIMENSION A AND B ARE TO BE DETERMINED AT DATUM PLANE -W-.

SOLDERING FOOTPRINT

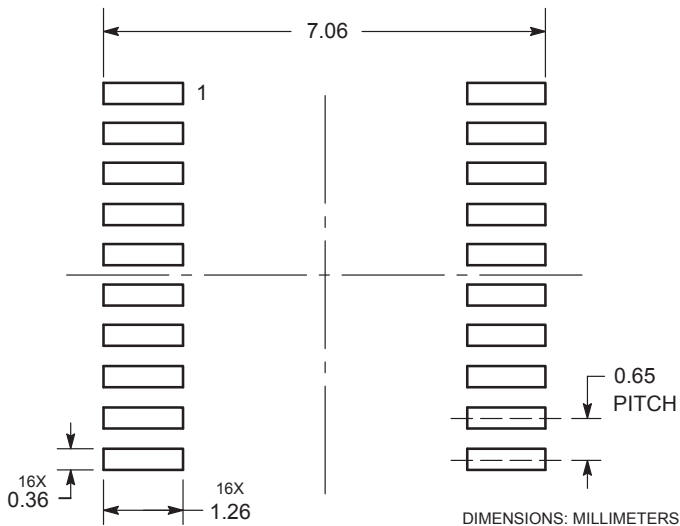

*For additional information on our Pb-Free strategy and soldering details, please download the ON Semiconductor Soldering and Mounting Techniques Reference Manual, SOLDERRM/D.

NCS37012

PACKAGE DIMENSIONS

QFN16 3x3, 0.5P
CASE 485G
ISSUE F

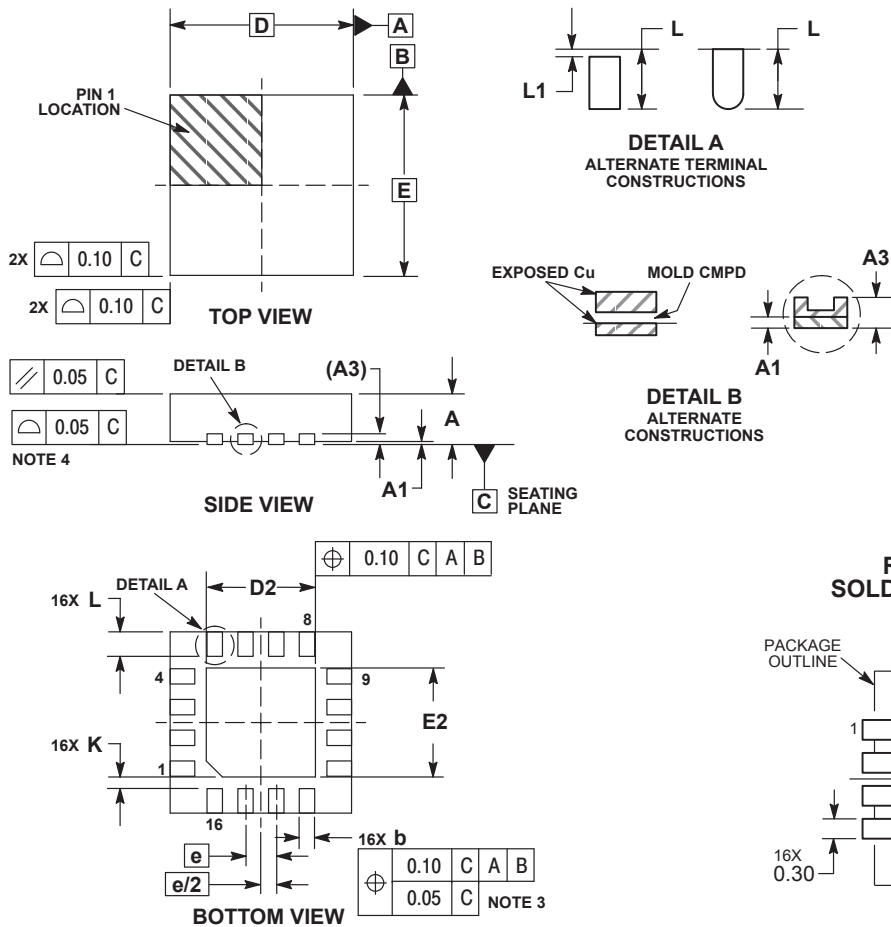

- NOTES:
1. DIMENSIONING AND TOLERANCING PER ASME Y14.5M, 1994.
 2. CONTROLLING DIMENSION: MILLIMETERS.
 3. DIMENSION b APPLIES TO PLATED TERMINAL AND IS MEASURED BETWEEN 0.25 AND 0.30 MM FROM TERMINAL.
 4. COPLANARITY APPLIES TO THE EXPOSED PAD AS WELL AS THE TERMINALS.

MILLIMETERS			
DIM	MIN	NOM	MAX
A	0.80	0.90	1.00
A1	0.00	0.03	0.05
A3	0.20 REF		
b	0.18	0.24	0.30
D	3.00 BSC		
D2	1.65	1.75	1.85
E	3.00 BSC		
E2	1.65	1.75	1.85
e	0.50 BSC		
K	0.18 TYP		
L	0.30	0.40	0.50
L1	0.00	0.08	0.15

*For additional information on our Pb-Free strategy and soldering details, please download the ON Semiconductor Soldering and Mounting Techniques Reference Manual, SOLDERRM/D.

ON Semiconductor and are trademarks of Semiconductor Components Industries, LLC dba ON Semiconductor or its subsidiaries in the United States and/or other countries. ON Semiconductor owns the rights to a number of patents, trademarks, copyrights, trade secrets, and other intellectual property. A listing of ON Semiconductor's product/patent coverage may be accessed at www.onsemi.com/site/pdf/Patent-Marketing.pdf. ON Semiconductor reserves the right to make changes without further notice to any products herein. ON Semiconductor makes no warranty, representation or guarantee regarding the suitability of its products for any particular purpose, nor does ON Semiconductor assume any liability arising out of the application or use of any product or circuit, and specifically disclaims any and all liability, including without limitation special, consequential or incidental damages. Buyer is responsible for its products and applications using ON Semiconductor products, including compliance with all laws, regulations and safety requirements or standards, regardless of any support or applications information provided by ON Semiconductor. "Typical" parameters which may be provided in ON Semiconductor data sheets and/or specifications can and do vary in different applications and actual performance may vary over time. All operating parameters, including "Typicals" must be validated for each customer application by customer's technical experts. ON Semiconductor does not convey any license under its patent rights nor the rights of others. ON Semiconductor products are not designed, intended, or authorized for use as a critical component in life support systems or any FDA Class 3 medical devices or medical devices with a same or similar classification in a foreign jurisdiction or any devices intended for implantation in the human body. Should Buyer purchase or use ON Semiconductor products for any such unintended or unauthorized application, Buyer shall indemnify and hold ON Semiconductor and its officers, employees, subsidiaries, affiliates, and distributors harmless against all claims, costs, damages, and expenses, and reasonable attorney fees arising out of, directly or indirectly, any claim of personal injury or death associated with such unintended or unauthorized use, even if such claim alleges that ON Semiconductor was negligent regarding the design or manufacture of the part. ON Semiconductor is an Equal Opportunity/Affirmative Action Employer. This literature is subject to all applicable copyright laws and is not for resale in any manner.

PUBLICATION ORDERING INFORMATION

LITERATURE FULFILLMENT:
Literature Distribution Center for ON Semiconductor
19521 E. 32nd Pkwy, Aurora, Colorado 80011 USA
Phone: 303-675-2175 or 800-344-3860 Toll Free USA/Canada
Fax: 303-675-2176 or 800-344-3867 Toll Free USA/Canada
Email: orderlit@onsemi.com

N. American Technical Support: 800-282-9855 Toll Free USA/Canada
Europe, Middle East and Africa Technical Support:
Phone: 421 33 790 2910
Japan Customer Focus Center
Phone: 81-3-5817-1050

ON Semiconductor Website: www.onsemi.com
Order Literature: <http://www.onsemi.com/orderlit>
For additional information, please contact your local Sales Representative

Looking for pricing, stock, or lifecycle information?

Click below to explore more details on WIN SOURCE:

- ⊖ [View NCS37012MNTWG on WIN SOURCE](#)
- ⊖ [ON Semiconductor Information](#)

Optimize Your Supply Chain with WIN SOURCE Solutions

- ✓ Global Sourcing Solution
- ✓ Obsolete Management
- ✓ Cost Control Management
- ✓ Shortage Management
- ✓ Alternative Solution
- ✓ Excess Inventory Management