



**THE DATASHEET OF
NB100LVEP222FA**



2.5 V/3.3 V 2:1:15 Differential ECL/PECL $\div 1/\div 2$ Clock Driver



ON Semiconductor®

www.onsemi.com

NB100LVEP222

The NB100LVEP222 is a low skew 2:1:15 differential $\div 1/\div 2$ ECL fanout buffer designed with clock distribution in mind. The LVECL/LVPECL input signal pairs can be used in a differential configuration or single-ended (with V_{BB} output reference bypassed and connected to the unused input of a pair). Either of two fully differential clock inputs may be selected. Each of the four output banks of 2, 3, 4, and 6 differential pairs may be independently configured to fanout 1X or 1/2X of the input frequency. When the output banks are configured with the $\div 1$ mode, data can also be distributed. The LVEP222 specifically guarantees low output to output skew. Optimal design, layout, and processing minimize skew within a device and from lot to lot. This device is an improved version of the MC100LVE222 with higher speed capability and reduced skew.

The fsel pins and CLK_Sel pin are asynchronous control inputs. Any changes may cause indeterminate output states requiring an MR pulse to resynchronize any 1/2X outputs (See Figure 3). Unused output pairs should be left unterminated (open) to reduce power and switching noise.

The NB100LVEP222, as with most ECL devices, can be operated from a positive V_{CC}/V_{CC0} supply in LVPECL mode. This allows the LVEP222 to be used for high performance clock distribution in +2.5/3.3 V systems. In a PECL environment series or Thevenin line, terminations are typically used as they require no additional power supplies. For more information on using PECL, designers should refer to Application Note AN1406/D. For a SPICE model, refer to Application Note AN1560/D.

The V_{BB} pin, an internally generated voltage supply, is available to this device only. For single-ended LVPECL input conditions, the unused differential input is connected to V_{BB} as a switching reference voltage. V_{BB} may also rebias AC coupled inputs. When used, decouple V_{BB} and V_{CC}/V_{CC0} via a 0.01 μ F capacitor and limit current sourcing or sinking to 0.5 mA. When not used, V_{BB} should be left open. Single-ended CLK input operation is limited to a $V_{CC}/V_{CC0} \geq 3.0$ V in LVPECL mode, or $V_{EE} \leq -3.0$ V in NECL mode.

Features

- 20 ps Output-to-Output Skew
- 85 ps Part-to-Part Skew
- Selectable 1x or 1/2x Frequency Outputs
- LVPECL Mode Operating Range:
 $V_{CC}/V_{CC0} = 2.375$ V to 3.8 V with $V_{EE} = 0$ V
- NECL Mode Operating Range:
 $V_{CC}/V_{CC0} = 0$ V with $V_{EE} = -2.375$ V to -3.8 V
- Internal Input Pulldown Resistors
- Performance Upgrade to ON Semiconductor's MC100LVE222
- V_{BB} Output
- These Devices are Pb-Free, Halogen Free and are RoHS Compliant

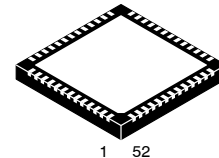

QFN-52
MN SUFFIX
CASE 485M

MARKING DIAGRAM*

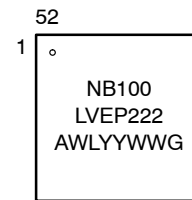

- A = Assembly Location
- WL = Wafer Lot
- YY = Year
- WW = Work Week
- G = Pb-Free Package

*For additional marking information, refer to Application Note [AND8002/D](#).

ORDERING INFORMATION

Device	Package	Shipping
NB100LVEP222MNG	QFN-52 (Pb-Free)	260 Units / Tray

NB100LVEP222

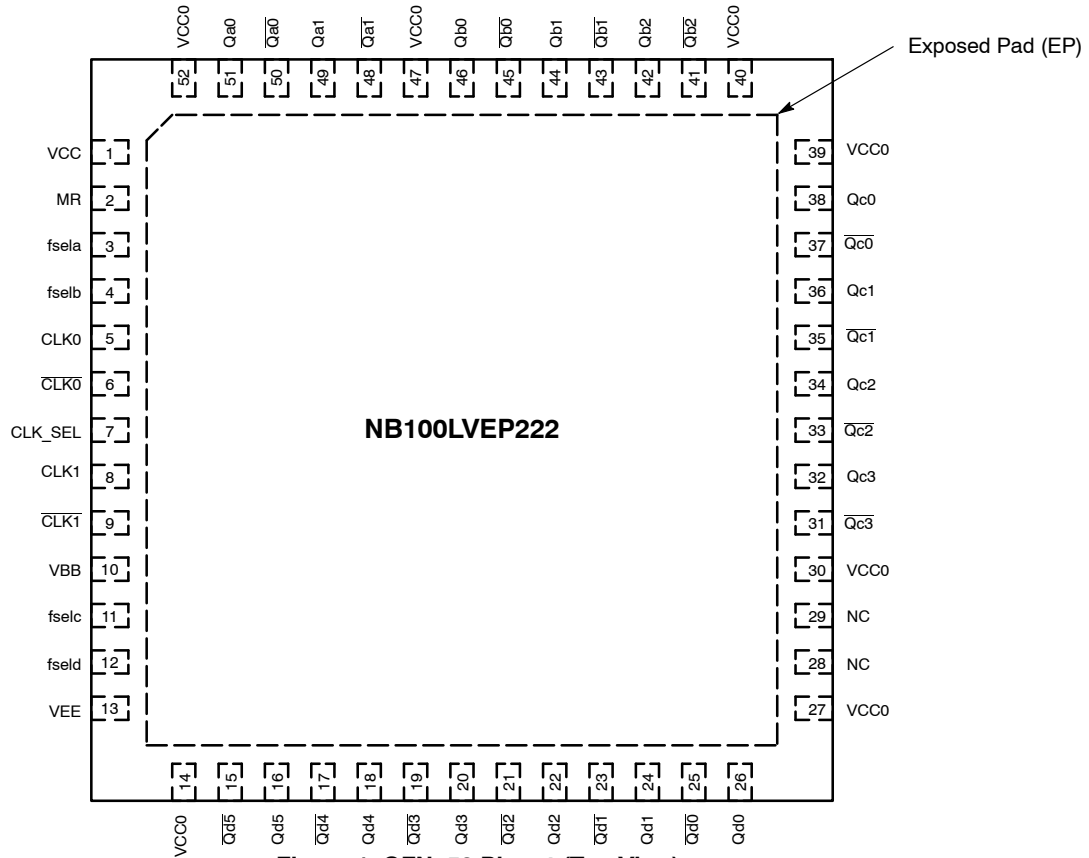

Figure 1. QFN-52 Pinout (Top View)

Table 1. PIN DESCRIPTION

PIN	FUNCTION
CLK0*, $\overline{\text{CLK0}}$ **	ECL Differential Input Clock
CLK1*, $\overline{\text{CLK1}}$ **	ECL Differential Input Clock
CLK_Sel*	ECL Clock Select
MR*	ECL Master Reset
Qa0:1, $\overline{\text{Qa0}}$:1	ECL Differential Outputs
Qb0:2, $\overline{\text{Qb0}}$:2	ECL Differential Outputs
Qc0:3, $\overline{\text{Qc0}}$:3	ECL Differential Outputs
Qd0:5, $\overline{\text{Qd0}}$:5	ECL Differential Outputs
fseln*	ECL $\div 1$ or $\div 2$ Select
V _{BB}	Reference Voltage Output
V _{CC} , V _{CC0}	Positive Supply, V _{CC} = V _{CC0}
V _{EE} ***	Negative Supply
NC	No Connect

* Pins will default LOW when left open.

** Pins will default HIGH when left open.

*** The thermally conductive exposed pad on the bottom of the package is electrically connected to V_{EE} internally.

Table 2. FUNCTION TABLE

Input	Function	
	L	H
MR	Active	Reset
CLK_Sel	CLK0	CLK1
fseln	$\div 1$	$\div 2$

NB100LVEP222

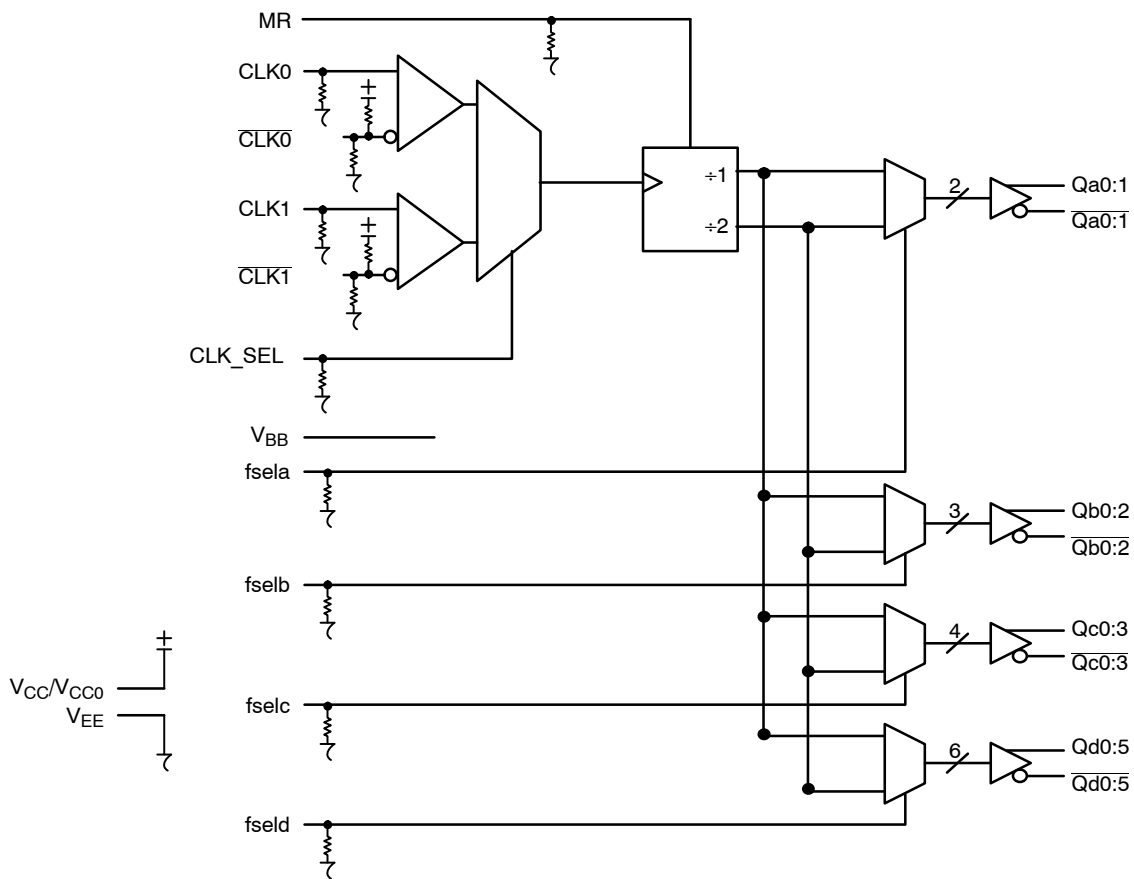

Figure 2. Logic Diagram

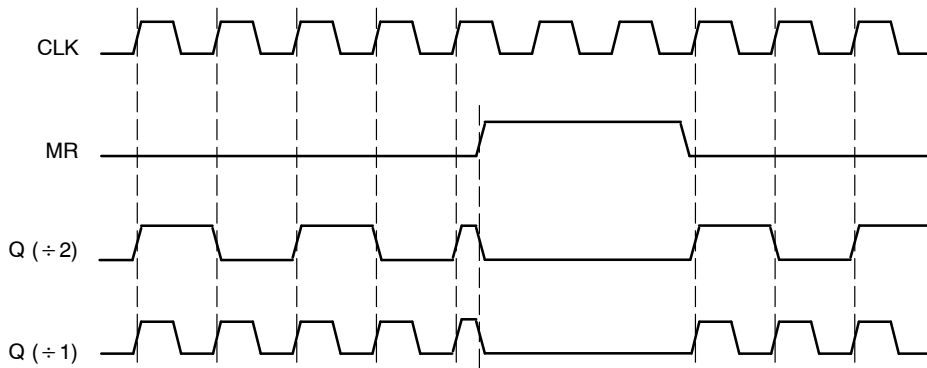

Figure 3. Master Reset (MR) Timing Diagram

NB100LVEP222

Table 3. ATTRIBUTES

Characteristics	Value
Internal Input Pulldown Resistor	75 kΩ
Internal Input Pullup Resistor	37.5 kΩ
ESD Protection Human Body Model Machine Model Charged Device Model	> 2 kV > 200 V > 2 kV
Moisture Sensitivity, Indefinite Time Out of Drypack (Note 1)	Pb-Free Pkg
QFN-52	Level 2
Flammability Rating Oxygen Index: 28 to 34	UL 94 V-O @ 0.125 in
Transistor Count	821 Devices
Meets or Exceeds JEDEC Spec EIA/JESD78 IC Latchup Test	

1. For additional information, refer to Application Note [AND8003/D](#).

Table 4. MAXIMUM RATINGS

Symbol	Parameter	Condition 1	Condition 2	Rating	Unit
V_{CC}/V_{CC0}	PECL Mode Power Supply	$V_{EE} = 0\text{ V}$		6	V
V_{EE}	NECL Mode Power Supply	$V_{CC}/V_{CC0} = 0\text{ V}$		-6	V
V_I	PECL Mode Input Voltage NECL Mode Input Voltage	$V_{EE} = 0\text{ V}$ $V_{CC}/V_{CC0} = 0\text{ V}$	$V_I \leq V_{CC}/V_{CC0}$ $V_I \geq V_{EE}$	6 to 0 -6 to 0	V V
I_{out}	Output Current	Continuous Surge		50 100	mA mA
I_{BB}	V_{BB} Sink/Source			±0.5	mA
T_A	Operating Temperature Range			-40 to +85	°C
T_{stg}	Storage Temperature Range			-65 to +150	°C
θ_{JA}	Thermal Resistance (Junction-to-Ambient) (Note)	0 lfpm 500 lfpm	QFN-52 QFN-52	25 19.6	°C/W °C/W
θ_{JC}	Thermal Resistance (Junction-to-Case) (Note)	2S2P	QFN-52	21	°C/W
T_{sol}	Wave Solder	< 2 to 3 sec @ 248°C		265	°C

Stresses exceeding those listed in the Maximum Ratings table may damage the device. If any of these limits are exceeded, device functionality should not be assumed, damage may occur and reliability may be affected.

NB100LVEP222

Table 5. LVPECL DC CHARACTERISTICS $V_{CC} = V_{CC0} = 2.5\text{ V}$; $V_{EE} = 0\text{ V}$ (Note 2)

Symbol	Characteristic	-40°C			25°C			85°C			Unit
		Min	Typ	Max	Min	Typ	Max	Min	Typ	Max	
I_{EE}	Power Supply Current	100	125	150	104	130	156	112	140	168	mA
V_{OH}	Output HIGH Voltage (Note 3)	1355	1480	1605	1355	1480	1605	1355	1480	1605	mV
V_{OL}	Output LOW Voltage (Note 3)	555	680	900	555	680	900	555	680	900	mV
V_{IH}	Input HIGH Voltage (Single-Ended) (Note 4)	1335		1620	1335		1620	1275		1620	mV
V_{IL}	Input LOW Voltage (Single-Ended) (Note 4)	555		900	555		900	555		900	mV
V_{IHCMR}	Input HIGH Voltage Common Mode Range (Differential Configuration) (Note 5) (Figure 5)	1.2		2.5	1.2		2.5	1.2		2.5	V
I_{IH}	Input HIGH Current			150			150			150	μA
I_{IL}	Input LOW Current	CLK CLK	0.5 -150		0.5 -150			0.5 -150			μA

NOTE: Device will meet the specifications after thermal equilibrium has been established when mounted in a test socket or printed circuit board with maintained transverse airflow greater than 500 lfm.

- Input and output parameters vary 1:1 with V_{CC}/V_{CC0} . V_{EE} can vary + 0.125 V to -1.3 V.
- All loading with 50 Ω to $V_{CC}/V_{CC0} - 2.0\text{ V}$.
- Do not use V_{BB} Pin #10 at $V_{CC}/V_{CC0} < 3.0\text{ V}$ (see [AND8066/D](#)).
- V_{IHCMR} min varies 1:1 with V_{EE} , V_{IHCMR} max varies 1:1 with V_{CC}/V_{CC0} . The V_{IHCMR} range is referenced to the most positive side of the differential input signal.

Table 6. LVPECL DC CHARACTERISTICS $V_{CC} = V_{CC0} = 3.3\text{ V}$; $V_{EE} = 0.0\text{ V}$ (Note 6)

Symbol	Characteristic	-40°C			25°C			85°C			Unit
		Min	Typ	Max	Min	Typ	Max	Min	Typ	Max	
I_{EE}	Power Supply Current	100	125	150	104	130	156	112	140	168	mA
V_{OH}	Output HIGH Voltage (Note 7)	2155	2280	2405	2155	2280	2405	2155	2280	2405	mV
V_{OL}	Output LOW Voltage (Note 7)	1355	1480	1700	1355	1480	1700	1355	1480	1700	mV
V_{IH}	Input HIGH Voltage (Single-Ended)	2135		2420	2135		2420	2135		2420	mV
V_{IL}	Input LOW Voltage (Single-Ended)	1355		1700	1355		1700	1355		1700	mV
V_{BB}	Output Reference Voltage (Note 8)	1775	1875	1975	1775	1875	1975	1775	1875	1975	mV
V_{IHCMR}	Input HIGH Voltage Common Mode Range (Differential Configuration) (Note 9) (Figure 5)	1.2		3.3	1.2		3.3	1.2		3.3	V
I_{IH}	Input HIGH Current			150			150			150	μA
I_{IL}	Input LOW Current	CLK CLK	0.5 -150		0.5 -150			0.5 -150			μA

NOTE: Device will meet the specifications after thermal equilibrium has been established when mounted in a test socket or printed circuit board with maintained transverse airflow greater than 500 lfm.

- Input and output parameters vary 1:1 with V_{CC}/V_{CC0} . V_{EE} can vary + 0.925 V to -0.5 V.
- All loading with 50 Ω to $V_{CC}/V_{CC0} - 2.0\text{ V}$.
- Single-Ended input operation is limited $V_{CC}/V_{CC0} \geq 3.0\text{ V}$ in LVPECL mode.
- V_{IHCMR} min varies 1:1 with V_{EE} , V_{IHCMR} max varies 1:1 with V_{CC}/V_{CC0} . The V_{IHCMR} range is referenced to the most positive side of the differential input signal.

NB100LVEP222

Table 7. LVNECL DC CHARACTERISTICS $V_{CC} = V_{CC0} = 0.0\text{ V}$; $V_{EE} = -3.8\text{ V}$ to -2.375 V (Note 10)

Symbol	Characteristic	-40°C			25°C			85°C			Unit
		Min	Typ	Max	Min	Typ	Max	Min	Typ	Max	
I_{EE}	Power Supply Current	100	125	150	104	130	156	112	140	168	mA
V_{OH}	Output HIGH Voltage (Note 11)	-1145	-1020	-895	-1145	-1020	-895	-1145	-1020	-895	mV
V_{OL}	Output LOW Voltage (Note 11)	-1945	-1820	-1600	-1945	-1820	-1600	-1945	-1820	-1600	mV
V_{IH}	Input HIGH Voltage (Single-Ended)	-1165		-880	-1165		-880	-1165		-880	mV
V_{IL}	Input LOW Voltage (Single-Ended)	-1945		-1600	-1945		-1600	-1945		-1600	mV
V_{BB}	Output Reference Voltage (Note 12)	-1525	-1425	-1325	-1525	-1425	-1325	-1525	-1425	-1325	mV
V_{IHCMR}	Input HIGH Voltage Common Mode Range (Differential Configuration) (Note 13) (Figure 5)	$V_{EE} + 1.2$		0.0	$V_{EE} + 1.2$		0.0	$V_{EE} + 1.2$		0.0	V
I_{IH}	Input HIGH Current			150			150			150	μA
I_{IL}	Input LOW Current	CLK CLK	0.5 -150		0.5 -150			0.5 -150			μA

NOTE: Device will meet the specifications after thermal equilibrium has been established when mounted in a test socket or printed circuit board with maintained transverse airflow greater than 500 lpm.

10. Input and output parameters vary 1:1 with V_{CC}/V_{CC0} .

11. All loading with $50\ \Omega$ to $V_{CC}/V_{CC0} - 2.0\text{ V}$.

12. Single-Ended input operation is limited $V_{EE} \leq -3.0\text{ V}$ in NECL mode.

13. V_{IHCMR} min varies 1:1 with V_{EE} , V_{IHCMR} max varies 1:1 with V_{CC}/V_{CC0} . The V_{IHCMR} range is referenced to the most positive side of the differential input signal.

NB100LVEP222

Table 8. AC CHARACTERISTICS $V_{CC} = V_{CC0} = 2.375$ to 3.8 V; $V_{EE} = 0.0$ V or $V_{CC} = V_{CC0} = 0.0$ V; $V_{EE} = -2.375$ to -3.8 V
(Note 14)

Symbol	Characteristic	-40°C			25°C			85°C			Unit
		Min	Typ	Max	Min	Typ	Max	Min	Typ	Max	
V_{Opp}	Differential Output Voltage (Figure 4) $f_{out} = 50$ MHz $f_{out} = 0.8$ GHz $f_{out} = 1.0$ GHz	500 550 500	600 650 650		500 525 425	600 650 650		500 500 400	600 650 600		mV
t_{PLH} t_{PHL}	Propagation Delay (Differential Configuration) CLKx-Qx MR-Qxx	650 700	800 900	900 1200	700 700	875 900	1000 1200	850 700	975 900	1150 1200	ps
t_{skew}	Within-Device Skew (Note 15) (+1 Mode) - Qa[0:1] - Qb[0:2] - Qc[0:3] - Qd[0:5] - QaN, QbN, QdN - All Outputs		10 10 20 10	40 40 60 40		10 10 20 10	40 40 60 40		10 10 20 10	40 40 60 40	ps
t_{skew}	Within-Device Skew (Note 15) (+2 Mode) - Qa[0:1] - Qb[0:2] - Qc[0:3] - Qd[0:5] - QaN, QbN, QdN - All Outputs		15 15 20 15	70 70 70 70		10 10 20 10	40 40 50 40		15 10 15 15	70 40 70 70	ps
t_{skew}	Device-to-Device Skew (Differential Configuration) (Note 16)		85	300		85	300		85	300	ps
t_{JITTER}	Random Clock Jitter (Figure 4) (RMS)		1	5		1	4		1	5	ps
V_{PP}	Input Swing (Differential Configuration) (Note 17) (Figure 5)	150	800	1200	150	800	1200	150	800	1200	mV
DCO	Output Duty Cycle	49.5	50	50.5	49.5	50	50.5	49.5	50	50.5	%
t_r/t_f	Output Rise/Fall Time 20%-80%	100	200	300	100	200	300	150	250	350	ps

NOTE: Device will meet the specifications after thermal equilibrium has been established when mounted in a test socket or printed circuit board with maintained transverse airflow greater than 500 lfm.

14. Measured with LVPECL 750 mV source, 50% duty cycle clock source. All outputs loaded with 50 Ω to $V_{CC}/V_{CC0} - 2.0$ V.

15. Skew is measured between outputs under identical transitions and operating conditions.

16. Device-to-Device skew for identical transitions at identical V_{CC}/V_{CC0} levels.

17. V_{PP} is the differential configuration input voltage swing required to maintain AC characteristics including t_{PD} and device-to-device skew.

NB100LVEP222

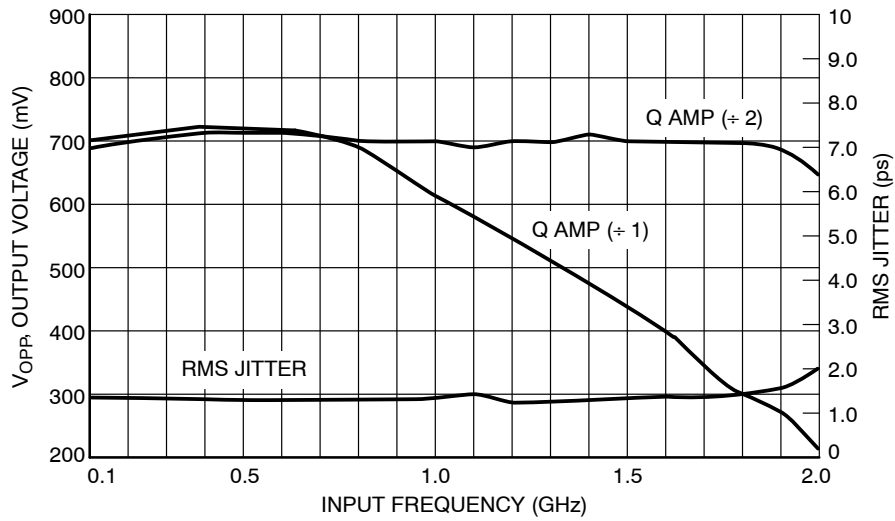

Figure 4. Output Voltage (V_{OPP}) versus Input Frequency and Random Clock Jitter (t_{JITTER}) @ 25°C

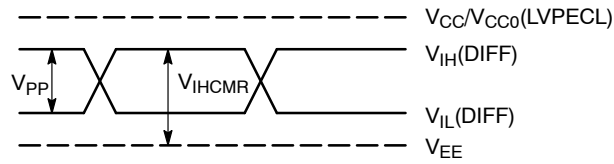

Figure 5. LVPECL Differential Input Levels

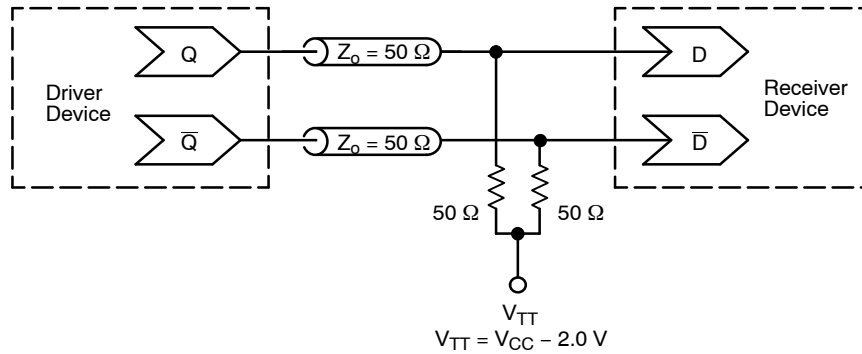

Figure 6. Typical Termination for Output Driver and Device Evaluation
(See Application Note [AND8020/D](#) – Termination of ECL Logic Devices.)

Resource Reference of Application Notes

- AN1405/D** – ECL Clock Distribution Techniques
- AN1406/D** – Designing with PECL (ECL at +5.0 V)
- AN1503/D** – ECLinPS™ I/O SPiCE Modeling Kit
- AN1504/D** – Metastability and the ECLinPS Family
- AN1568/D** – Interfacing Between LVDS and ECL
- AN1642/D** – The ECL Translator Guide
- AND8001/D** – Odd Number Counters Design
- AND8002/D** – Marking and Date Codes
- AND8020/D** – Termination of ECL Logic Devices
- AND8066/D** – Interfacing with ECLinPS
- AND8090/D** – AC Characteristics of ECL Devices

MECHANICAL CASE OUTLINE

PACKAGE DIMENSIONS

ON Semiconductor®



QFN52 8x8, 0.5P
CASE 485M-01
ISSUE C

DATE 16 FEB 2010

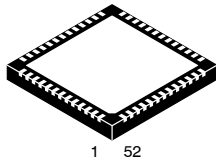

SCALE 2:1

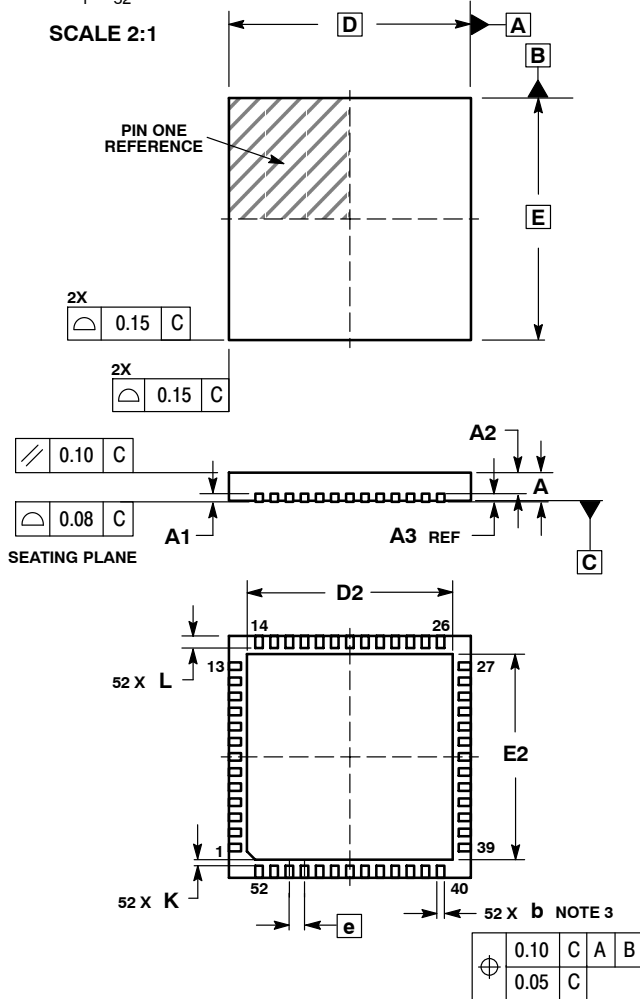

NOTES:

1. DIMENSIONING AND TOLERANCING PER ASME Y14.5M, 1994.
2. CONTROLLING DIMENSION: MILLIMETERS
3. DIMENSION b APPLIES TO PLATED TERMINAL AND IS MEASURED BETWEEN 0.25 AND 0.30 MM FROM TERMINAL.
4. COPLANARITY APPLIES TO THE EXPOSED PAD AS WELL AS THE TERMINALS.

MILLIMETERS		
DIM	MIN	MAX
A	0.80	1.00
A1	0.00	0.05
A2	0.60	0.80
A3	0.20 REF	
b	0.18	0.30
D	8.00 BSC	
D2	6.50	6.80
E	8.00 BSC	
E2	6.50	6.80
e	0.50 BSC	
K	0.20	---
L	0.30	0.50

GENERIC MARKING DIAGRAM

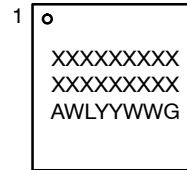

- XXXXXXXXXX = Device Code
- A = Assembly Site
- WL = Wafer Lot
- YY = Year
- WW = Work Week
- G = Pb-Free Package

RECOMMENDED SOLDERING FOOTPRINT

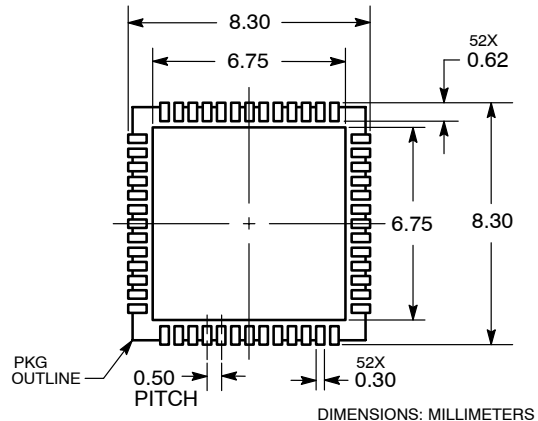

DOCUMENT NUMBER:	98AON12057D	Electronic versions are uncontrolled except when accessed directly from the Document Repository. Printed versions are uncontrolled except when stamped "CONTROLLED COPY" in red.
DESCRIPTION:	52 PIN QFN, 8X8, 0.5P	PAGE 1 OF 1

ON Semiconductor and are trademarks of Semiconductor Components Industries, LLC dba ON Semiconductor or its subsidiaries in the United States and/or other countries. ON Semiconductor reserves the right to make changes without further notice to any products herein. ON Semiconductor makes no warranty, representation or guarantee regarding the suitability of its products for any particular purpose, nor does ON Semiconductor assume any liability arising out of the application or use of any product or circuit, and specifically disclaims any and all liability, including without limitation special, consequential or incidental damages. ON Semiconductor does not convey any license under its patent rights nor the rights of others.

onsemi, **Onsemi**, and other names, marks, and brands are registered and/or common law trademarks of Semiconductor Components Industries, LLC dba "**onsemi**" or its affiliates and/or subsidiaries in the United States and/or other countries. **onsemi** owns the rights to a number of patents, trademarks, copyrights, trade secrets, and other intellectual property. A listing of **onsemi**'s product/patent coverage may be accessed at www.onsemi.com/site/pdf/Patent-Marking.pdf. **onsemi** reserves the right to make changes at any time to any products or information herein, without notice. The information herein is provided "as-is" and **onsemi** makes no warranty, representation or guarantee regarding the accuracy of the information, product features, availability, functionality, or suitability of its products for any particular purpose, nor does **onsemi** assume any liability arising out of the application or use of any product or circuit, and specifically disclaims any and all liability, including without limitation special, consequential or incidental damages. Buyer is responsible for its products and applications using **onsemi** products, including compliance with all laws, regulations and safety requirements or standards, regardless of any support or applications information provided by **onsemi**. "Typical" parameters which may be provided in **onsemi** data sheets and/or specifications can and do vary in different applications and actual performance may vary over time. All operating parameters, including "Typicals" must be validated for each customer application by customer's technical experts. **onsemi** does not convey any license under any of its intellectual property rights nor the rights of others. **onsemi** products are not designed, intended, or authorized for use as a critical component in life support systems or any FDA Class 3 medical devices or medical devices with a same or similar classification in a foreign jurisdiction or any devices intended for implantation in the human body. Should Buyer purchase or use **onsemi** products for any such unintended or unauthorized application, Buyer shall indemnify and hold **onsemi** and its officers, employees, subsidiaries, affiliates, and distributors harmless against all claims, costs, damages, and expenses, and reasonable attorney fees arising out of, directly or indirectly, any claim of personal injury or death associated with such unintended or unauthorized use, even if such claim alleges that **onsemi** was negligent regarding the design or manufacture of the part. **onsemi** is an Equal Opportunity/Affirmative Action Employer. This literature is subject to all applicable copyright laws and is not for resale in any manner.

ADDITIONAL INFORMATION

TECHNICAL PUBLICATIONS:

Technical Library: www.onsemi.com/design/resources/technical-documentation
onsemi Website: www.onsemi.com

ONLINE SUPPORT: www.onsemi.com/support

For additional information, please contact your local Sales Representative at www.onsemi.com/support/sales

Looking for pricing, stock, or lifecycle information?

Click below to explore more details on WIN SOURCE:

 [View NB100LVEP222FA on WIN SOURCE](#)

 [ON Semiconductor](#) Information

Optimize Your Supply Chain with WIN SOURCE Solutions

-  Global Sourcing Solution
-  Obsolete Management
-  Cost Control Management
-  Shortage Management
-  Alternative Solution
-  Excess Inventory Management