



**THE DATASHEET OF
MT47H64M16BT-5E:A**



DDR2 SDRAM

MT47H256M4 – 32 Meg x 4 x 8 banks

MT47H128M8 – 16 Meg x 8 x 8 banks

MT47H64M16 – 8 Meg x 16 x 8 banks

For the latest data sheet, refer to Micron's Web site: <http://www.micron.com/ddr2>

Features

- RoHS compliant
- VDD = +1.8V ±0.1V, VDDQ = +1.8V ±0.1V
- JEDEC standard 1.8V I/O (SSTL_18-compatible)
- Differential data strobe (DQS, DQS#) option
- 4-bit prefetch architecture
- Duplicate output strobe (RDQS) option for x8
- DLL to align DQ and DQS transitions with CK
- 8 internal banks for concurrent operation
- Programmable CAS latency (CL)
- Posted CAS additive latency (AL)
- WRITE latency = READ latency – 1 t_{CK}
- Programmable burst lengths: 4 or 8
- Adjustable data-output drive strength
- 64ms, 8,192-cycle refresh
- On-die termination (ODT)
- Industrial temperature (IT) option
- Supports JEDEC clock jitter specification

Options

- Configuration

| | |
|-------------------------------------|-------|
| 256 Meg x 4 (32 Meg x 4 x 8 banks) | 256M4 |
| 128 Meg x 8 (16 Meg x 8 x 8 banks) | 128M8 |
| 64 Meg x 16 (8 Meg x 16 x 8 banks) | 64M16 |
- FBGA package (lead-free)

| | |
|-----------------------------------|----|
| 92-ball FBGA (11mm x 19mm) (:A) | BT |
| 84-ball FBGA (10mm x 16.5mm) (:D) | B7 |
| 68-ball FBGA (10mm x 16.5mm) (:D) | B7 |
- Timing – cycle time

| | |
|----------------------------|------|
| 5.0ns @ CL = 3 (DDR2-400) | -5E |
| 3.75ns @ CL = 4 (DDR2-533) | -37E |
| 3.0ns @ CL = 5 (DDR2-667) | -3 |
| 3.0ns @ CL = 4 (DDR2-667) | -3E |
| 2.5ns @ CL = 6 (DDR2-800) | -25 |
| 2.5ns @ CL = 5 (DDR2-800) | -25E |
- Self refresh

| | |
|-----------|------|
| Standard | None |
| Low-power | L |
- Operating temperature

| | |
|---|------|
| Commercial (0°C ≤ T _c ≤ 85°C) | None |
| Industrial (-40°C ≤ T _c ≤ 95°C; -40°C ≤ T _a ≤ 85°C) | IT |
- Revision

| | |
|--|-------|
| | :A/:D |
|--|-------|

Marking

Table 1: Configuration Addressing

| Architecture | 256 Meg x 4 | 128 Meg x 8 | 64 Meg x 16 |
|---------------|----------------------|----------------------|----------------------|
| Configuration | 32 Meg x 4 x 8 banks | 16 Meg x 4 x 8 banks | 8 Meg x 16 x 8 banks |
| Refresh Count | 8K | 8K | 8K |
| Row Addr. | 16K (A0–A13) | 16K (A0–A13) | 8K (A0–A12) |
| Bank Addr. | 8 (BA0–BA2) | 8 (BA0–BA2) | 8 (BA0–BA2) |
| Column Addr. | 2K (A0–A9, A11) | 1K (A0–A9) | 1K (A0–A9) |

Table 2: Key Timing Parameters

| Speed Grade | Data Rate (MHz) | | | | t _{RCD} (ns) | t _{RP} (ns) | t _{RC} (ns) |
|-------------|-----------------|--------|--------|--------|-----------------------|----------------------|----------------------|
| | CL = 3 | CL = 4 | CL = 5 | CL = 6 | | | |
| -5E | 400 | 400 | N/A | N/A | 15 | 15 | 55 |
| -37E | 400 | 533 | N/A | N/A | 15 | 15 | 55 |
| -3 | 400 | 533 | 667 | N/A | 15 | 15 | 55 |
| -3E | N/A | 667 | 667 | N/A | 12 | 12 | 54 |
| -25 | N/A | N/A | 667 | 800 | 15 | 15 | 55 |
| -25E | N/A | 533 | 800 | N/A | 12.5 | 12.5 | 55 |

Note: CL = CAS latency.

Table of Contents

Features 1

Part Numbers 7

FBGA Part Marking Decoder 7

General Description 7

 Industrial Temperature 8

 General Notes 8

Ball Assignment and Description 9

Functional Description 18

State Diagram 20

Initialization 21

Mode Register (MR) 24

 Burst Length 24

 Burst Type 25

 Operating Mode 26

 DLL RESET 26

 Write Recovery 26

 Power-Down Mode 27

 CAS Latency (CL) 27

Extended Mode Register (EMR) 28

DLL Enable/Disable 29

Output Drive Strength 30

DQS# Enable/Disable 30

RDQS Enable/Disable 30

Output Enable/Disable 30

On-Die Termination (ODT) 30

Off-Chip Driver (OCD) Impedance Calibration 31

Posted CAS Additive Latency (AL) 31

Extended Mode Register 2 32

Extended Mode Register 3 33

Command Truth Tables 34

DESELECT, NOP, and LM Commands 39

 DESELECT 39

 NO OPERATION (NOP) 39

 LOAD MODE (LM) 39

Bank/Row Activation 39

 ACTIVE Command 39

 ACTIVE Operation 39

READ Command 41

 READ Operation 41

WRITE Command 54

 WRITE Operation 54

PRECHARGE Command 65

 PRECHARGE Operation 65

SELF REFRESH Command 66

REFRESH Command 68

Power-Down Mode 69

Precharge Power-Down Clock Frequency Change 76

RESET Function 77

 (CKE LOW Anytime) 77

ODT Timing 79

 MRS Command to ODT Update Delay 80

| | |
|--|-----|
| Absolute Maximum Ratings | 87 |
| Temperature and Thermal Impedance | 87 |
| AC and DC Operating Conditions | 89 |
| Input Electrical Characteristics and Operating Conditions | 90 |
| Input Slew Rate Derating | 93 |
| Power and Ground Clamp Characteristics | 109 |
| AC Overshoot/Undershoot Specification | 110 |
| Output Electrical Characteristics and Operating Conditions | 111 |
| Full Strength Pull-Down Driver Characteristics | 113 |
| Full Strength Pull-Up Driver Characteristics | 114 |
| Reduced Strength Pull-Down Driver Characteristics | 115 |
| Reduced Strength Pull-Up Driver Characteristics | 116 |
| FBGA Package Capacitance | 117 |
| IDD Specifications and Conditions | 118 |
| IDD7 Conditions | 120 |
| AC Operating Specifications | 121 |
| Notes | 131 |
| Package Dimensions | 135 |

List of Figures

| | | |
|------------|---|----|
| Figure 1: | 1Gb DDR2 Part Numbers | 7 |
| Figure 2: | 84-Ball FBGA (x16) | 9 |
| Figure 3: | 68-Ball FBGA (x4, x8) | 10 |
| Figure 4: | 92-Ball FBGA (x16) | 13 |
| Figure 5: | 92-Ball FBGA (x4/x8) | 14 |
| Figure 6: | Functional Block Diagram – 64 Meg x 16 | 18 |
| Figure 7: | Functional Block Diagram – 128 Meg x 8 | 19 |
| Figure 8: | Functional Block Diagram – 256 Meg x 4 | 19 |
| Figure 9: | Simplified State Diagram | 20 |
| Figure 10: | DDR2 Power-up and Initialization | 21 |
| Figure 11: | Mode Register (MR) Definition | 25 |
| Figure 12: | CAS Latency (CL) | 28 |
| Figure 13: | Extended Mode Register Definition | 29 |
| Figure 14: | READ Latency | 31 |
| Figure 15: | WRITE Latency | 32 |
| Figure 16: | Extended Mode Register 2 (EMR2) Definition | 32 |
| Figure 17: | Extended Mode Register 3 (EMR3) Definition | 33 |
| Figure 18: | ACTIVE Command | 40 |
| Figure 19: | 8-Bank Activate Restriction | 40 |
| Figure 20: | READ Command | 42 |
| Figure 21: | Example: Meeting ^t RRD (MIN) and ^t RCD (MIN) | 42 |
| Figure 22: | READ Latency | 43 |
| Figure 23: | Consecutive READ Bursts | 44 |
| Figure 24: | Nonconsecutive READ Bursts | 45 |
| Figure 25: | READ Interrupted by READ | 45 |
| Figure 26: | READ-to-PRECHARGE – BL = 4 | 47 |
| Figure 27: | READ-to-PRECHARGE – BL = 8 | 47 |
| Figure 28: | READ-to-WRITE | 48 |
| Figure 29: | Bank Read – without Auto Precharge | 49 |
| Figure 30: | Bank Read – with Auto Precharge | 50 |
| Figure 31: | x4, x8 Data Output Timing – ^t DQSQ, ^t QH, and Data Valid Window | 51 |
| Figure 32: | x16 Data Output Timing – ^t DQSQ, ^t QH, and Data Valid Window | 52 |
| Figure 33: | Data Output Timing – ^t AC and ^t DQSCK | 53 |
| Figure 34: | WRITE Command | 54 |
| Figure 35: | WRITE Burst | 56 |
| Figure 36: | Consecutive WRITE-to-WRITE | 57 |
| Figure 37: | Nonconsecutive WRITE-to-WRITE | 57 |
| Figure 38: | Random WRITE Cycles | 58 |
| Figure 39: | WRITE Interrupted by WRITE | 58 |
| Figure 40: | WRITE-to-READ | 59 |
| Figure 41: | WRITE-to-PRECHARGE | 60 |
| Figure 42: | Bank Write – without Auto Precharge | 61 |
| Figure 43: | Bank Write – with Auto Precharge | 62 |
| Figure 44: | WRITE – DM Operation | 63 |
| Figure 45: | Data Input Timing | 64 |
| Figure 46: | PRECHARGE Command | 65 |
| Figure 47: | Self Refresh | 67 |
| Figure 48: | Refresh Mode | 68 |
| Figure 49: | Power-Down | 70 |
| Figure 50: | READ to Power-Down or Self Refresh Entry | 72 |
| Figure 51: | READ with Auto Precharge to Power-Down or Self Refresh Entry | 72 |
| Figure 52: | WRITE to Power-Down or Self-Refresh Entry | 73 |
| Figure 53: | WRITE with Auto Precharge to Power-Down or Self Refresh Entry | 73 |
| Figure 54: | REFRESH Command to Power-Down Entry | 74 |
| Figure 55: | ACTIVE Command to Power-Down Entry | 74 |
| Figure 56: | PRECHARGE Command to Power-Down Entry | 75 |

| | | |
|------------|--|-----|
| Figure 57: | LOAD MODE Command to Power-Down Entry | 75 |
| Figure 58: | Input Clock Frequency Change During Precharge Power-Down Mode | 76 |
| Figure 59: | RESET Function | 78 |
| Figure 60: | ODT Timing for Entering and Exiting Power-Down Mode | 80 |
| Figure 61: | Timing for MRS Command to ODT Update Delay | 80 |
| Figure 62: | ODT Timing for Active or Fast-Exit Power-Down Mode | 81 |
| Figure 63: | ODT Timing for Slow-Exit or Precharge Power-Down Modes | 82 |
| Figure 64: | ODT Turn-off Timings When Entering Power-Down Mode | 83 |
| Figure 65: | ODT Turn-On Timing When Entering Power-Down Mode | 84 |
| Figure 66: | ODT Turn-Off Timing When Exiting Power-Down Mode | 85 |
| Figure 67: | ODT Turn-on Timing When Exiting Power-Down Mode | 86 |
| Figure 68: | Example Temperature Test Point Location | 88 |
| Figure 69: | Single-Ended Input Signal Levels | 90 |
| Figure 70: | Differential Input Signal Levels | 91 |
| Figure 71: | Nominal Slew Rate for t_{IS} | 95 |
| Figure 72: | Tangent Line for t_{IS} | 96 |
| Figure 73: | Nominal Slew Rate for t_{IH} | 97 |
| Figure 74: | Tangent Line for t_{IH} | 98 |
| Figure 75: | Nominal Slew Rate for t_{DS} | 103 |
| Figure 76: | Tangent Line for t_{DS} | 104 |
| Figure 77: | Nominal Slew Rate for t_{DH} | 105 |
| Figure 78: | Tangent Line for t_{DH} | 106 |
| Figure 79: | AC Input Test Signal Waveform Command/Address Balls | 107 |
| Figure 80: | AC Input Test Signal Waveform for Data with DQS, DQS# (Differential) | 107 |
| Figure 81: | AC Input Test Signal Waveform for Data with DQS (single-ended) | 108 |
| Figure 82: | AC Input Test Signal Waveform (differential) | 108 |
| Figure 83: | Input Clamp Characteristics | 109 |
| Figure 84: | Overshoot | 110 |
| Figure 85: | Undershoot | 110 |
| Figure 86: | Differential Output Signal Levels | 111 |
| Figure 87: | Output Slew Rate Load | 112 |
| Figure 88: | Full Strength Pull-Down Characteristics | 113 |
| Figure 89: | Full Strength Pull-Up Characteristics | 114 |
| Figure 90: | Reduced Strength Pull-Down Characteristics | 115 |
| Figure 91: | Reduced Strength Pull-Up Characteristics | 116 |
| Figure 92: | 84-Ball FBGA Package – 10mm x 16.5mm (x16) | 135 |
| Figure 93: | 68-Ball FBGA Package – 10mm x 16.5mm (x4/x8) | 136 |
| Figure 94: | 92-Ball FBGA Package – 11mm x 19mm (x4/x8/x16) | 137 |

List of Tables

| | | |
|-----------|--|-----|
| Table 1: | Configuration Addressing | 1 |
| Table 2: | Key Timing Parameters | 1 |
| Table 3: | 84-/68-Ball Descriptions – 256 Meg x 4, 128 Meg x 8, 64 Meg x 16. | 11 |
| Table 4: | 92-Ball Descriptions – 256 Meg x 4, 128 Meg x 8, 64 Meg x 16. | 15 |
| Table 5: | Burst Definition. | 26 |
| Table 6: | Truth Table – DDR2 Commands. | 34 |
| Table 7: | Truth Table – Current State Bank <i>n</i> – Command to Bank <i>n</i> | 35 |
| Table 8: | Truth Table – Current State Bank <i>n</i> – Command to Bank <i>m</i> | 37 |
| Table 9: | Minimum Delay with Auto Precharge Enabled | 38 |
| Table 10: | READ Using Concurrent Auto Precharge | 46 |
| Table 11: | WRITE Using Concurrent Auto Precharge | 55 |
| Table 12: | CKE Truth Table | 71 |
| Table 13: | DDR2-400/533 ODT Timing for Active and Fast-Exit Power-Down Modes | 81 |
| Table 14: | DDR2-400/533 ODT Timing for Slow-Exit and Precharge Power-Down Modes | 82 |
| Table 15: | DDR2-400/533 ODT Turn-off Timings When Entering Power-Down Mode. | 83 |
| Table 16: | DDR2-400/533 ODT Turn-on Timing When Entering Power-Down Mode. | 84 |
| Table 17: | DDR2-400/533 ODT Turn-off Timing When Exiting Power-Down Mode | 85 |
| Table 18: | DDR2-400/533 ODT Turn-On Timing When Exiting Power-Down Mode. | 86 |
| Table 17: | Absolute Maximum DC Ratings | 87 |
| Table 18: | Temperature Limits | 88 |
| Table 19: | Thermal Impedance. | 88 |
| Table 20: | Recommended DC Operating Conditions (SSTL_18). | 89 |
| Table 21: | ODT DC Electrical Characteristics | 89 |
| Table 22: | Input DC Logic Levels | 90 |
| Table 23: | Input AC Logic Levels | 90 |
| Table 24: | Differential Input Logic Levels. | 91 |
| Table 25: | AC Input Test Conditions | 92 |
| Table 26: | DDR2-400/533 Setup and Hold Time Derating Values (^t IS and ^t IH) | 94 |
| Table 27: | DDR2-667 Setup and Hold Time Derating Values (^t IS and ^t IH) | 94 |
| Table 28: | DDR2-400/533 ^t DS, ^t DH Derating Values with Differential Strobe | 99 |
| Table 29: | DDR2-667 ^t DS, ^t DH Derating Values with Differential Strobe | 100 |
| Table 30: | Single-Ended DQS Slew Rate Derating Values Using ^t DS _b and ^t DH _b | 101 |
| Table 31: | Single-Ended DQS Slew Rate Fully Derated (DQS, DQ at VREF) at DDR2-667 | 101 |
| Table 32: | Single-Ended DQS Slew Rate Fully Derated (DQS, DQ at VREF) at DDR2-533 | 102 |
| Table 33: | Single-Ended DQS Slew Rate Fully Derated (DQS, DQ at VREF) at DDR2-400 | 102 |
| Table 34: | Input Clamp Characteristics | 109 |
| Table 35: | Address and Control Balls. | 110 |
| Table 36: | Clock, Data, Strobe, and Mask Balls | 110 |
| Table 37: | Differential AC Output Parameters. | 111 |
| Table 38: | Output DC Current Drive | 112 |
| Table 39: | Output Characteristics. | 112 |
| Table 40: | Full Strength Pull-Down Current (mA) | 113 |
| Table 41: | Full Strength Pull-Up Current (mA) | 114 |
| Table 42: | Reduced Strength Pull-Down Current (mA) | 115 |
| Table 43: | Reduced Strength Pull-Up Current (mA) | 116 |
| Table 44: | Input Capacitance | 117 |
| Table 45: | DDR2 IDD Specifications and Conditions (continued). | 118 |
| Table 46: | General IDD Parameters | 120 |
| Table 47: | IDD7 Timing Patterns (8-bank) | 120 |
| Table 48: | AC Operating Conditions for -3E, -3, -37E, and -5E Speeds | 121 |
| Table 49: | AC Operating Conditions for -25E and -25 Speeds | 127 |

Part Numbers

Figure 1: 1Gb DDR2 Part Numbers

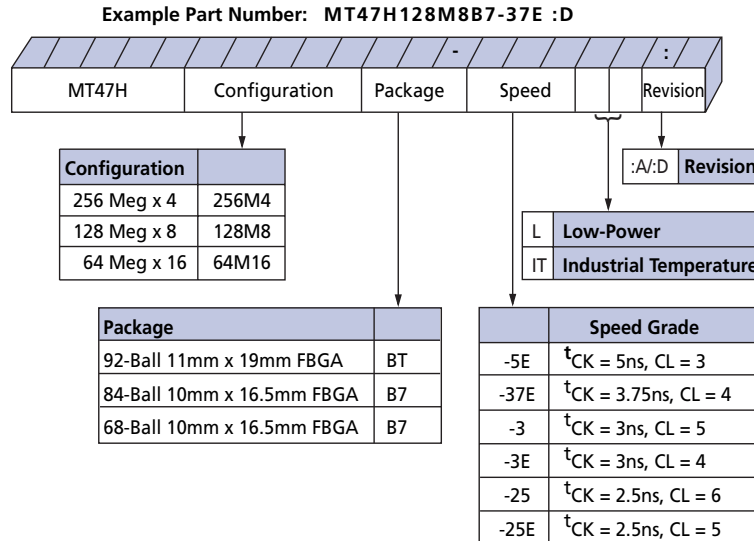

Note: Not all speeds and configurations are available. Contact Micron sales for current revision.

FBGA Part Marking Decoder

Due to space limitations, FBGA-packaged components have an abbreviated part marking that is different from the part number. Micron's FBGA Part Marking Decoder is available at www.micron.com/decoder.

General Description

The 1Gb DDR2 SDRAM is a high-speed CMOS, dynamic random access memory containing 1,073,741,824 bits. It is internally configured as an 8-bank DRAM. The functional block diagrams of the all device configurations are shown in "Functional Description" on page 18. Ball assignments and signal descriptions are shown in "Ball Assignment and Description" on page 9.

The 1Gb DDR2 SDRAM uses a double data rate architecture to achieve high-speed operation. The double data rate architecture is essentially a $4n$ -prefetch architecture, with an interface designed to transfer two data words per clock cycle at the I/O balls. A single read or write access for the 1Gb DDR2 SDRAM effectively consists of a single $4n$ -bit-wide, one-clock-cycle data transfer at the internal DRAM core and four corresponding n -bit-wide, one-half-clock-cycle data transfers at the I/O balls.

A bidirectional data strobe (DQS, DQS#) is transmitted externally, along with data, for use in data capture at the receiver. DQS is a strobe transmitted by the DDR2 SDRAM during READs and by the memory controller during WRITEs. DQS is edge-aligned with data for READs and center-aligned with data for WRITEs. The x16 offering has two data strobes, one for the lower byte (LDQS, LDQS#) and one for the upper byte (UDQS, UDQS#).

The 1Gb DDR2 SDRAM operates from a differential clock (CK and CK#); the crossing of CK going HIGH and CK# going LOW will be referred to as the positive edge of CK. Commands (address and control signals) are registered at every positive edge of CK. Input data is registered on both edges of DQS, and output data is referenced to both edges of DQS as well as to both edges of CK.

Read and write accesses to the DDR2 SDRAM are burst-oriented; accesses start at a selected location and continue for a programmed number of locations in a programmed sequence. Accesses begin with the registration of an ACTIVE command, which is then followed by a READ or WRITE command. The address bits registered coincident with the ACTIVE command are used to select the bank and row to be accessed. The address bits registered coincident with the READ or WRITE command are used to select the bank and the starting column location for the burst access.

The DDR2 SDRAM provides for programmable read or write burst lengths of four or eight locations. DDR2 SDRAM supports interrupting a burst read of eight with another read or a burst write of eight with another write. An auto precharge function may be enabled to provide a self-timed row precharge that is initiated at the end of the burst access.

As with standard DDR SDRAMs, the pipelined, multibank architecture of DDR2 SDRAMs allows for concurrent operation, thereby providing high, effective bandwidth by hiding row precharge and activation time.

A self refresh mode is provided, along with a power-saving, power-down mode.

All inputs are compatible with the JEDEC standard for SSTL_18. All full drive-strength outputs are SSTL_18-compatible.

Industrial Temperature

The industrial temperature (IT) device has two simultaneous requirements: ambient temperature surrounding the device cannot exceed -40°C or $+85^{\circ}\text{C}$, and the case temperature cannot exceed -40°C or 95°C . JEDEC specifications require the refresh rate to double when T_C exceeds 85°C ; this also requires use of the high-temperature self refresh option. Additionally, ODT resistance and the input/output impedance must be derated when the T_C is $< 0^{\circ}\text{C}$ or $> 85^{\circ}\text{C}$.

General Notes

- The functionality and the timing specifications discussed in this data sheet are for the DLL-enabled mode of operation.
- Throughout the data sheet, the various figures and text refer to DQs as “DQ.” The DQ term is to be interpreted as any and all DQ collectively, unless specifically stated otherwise. Additionally, the x16 is divided into 2 bytes, the lower byte and upper byte. For the lower byte (DQ0–DQ7), DM refers to LDM and DQS refers to LDQS. For the upper byte (DQ8–DQ15), DM refers to UDM and DQS refers to UDQS.
- Complete functionality is described throughout the document, and any page or diagram may have been simplified to convey a topic and may not be inclusive of all requirements.
- Any specific requirement takes precedence over a general statement.

Ball Assignment and Description

Figure 2: 84-Ball FBGA (x16)
10mm x 16.5mm (top view)

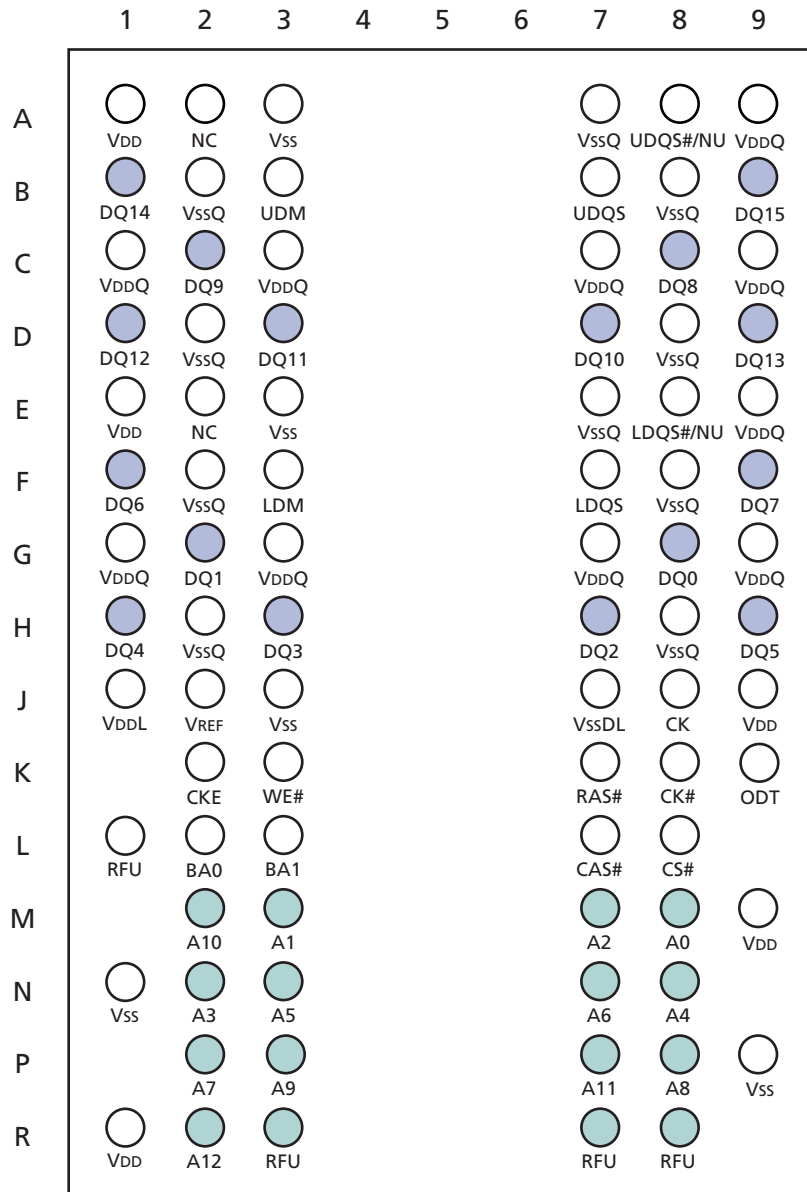

Figure 3: 68-Ball FBGA (x4, x8)
10mm x 16.5mm (top view)

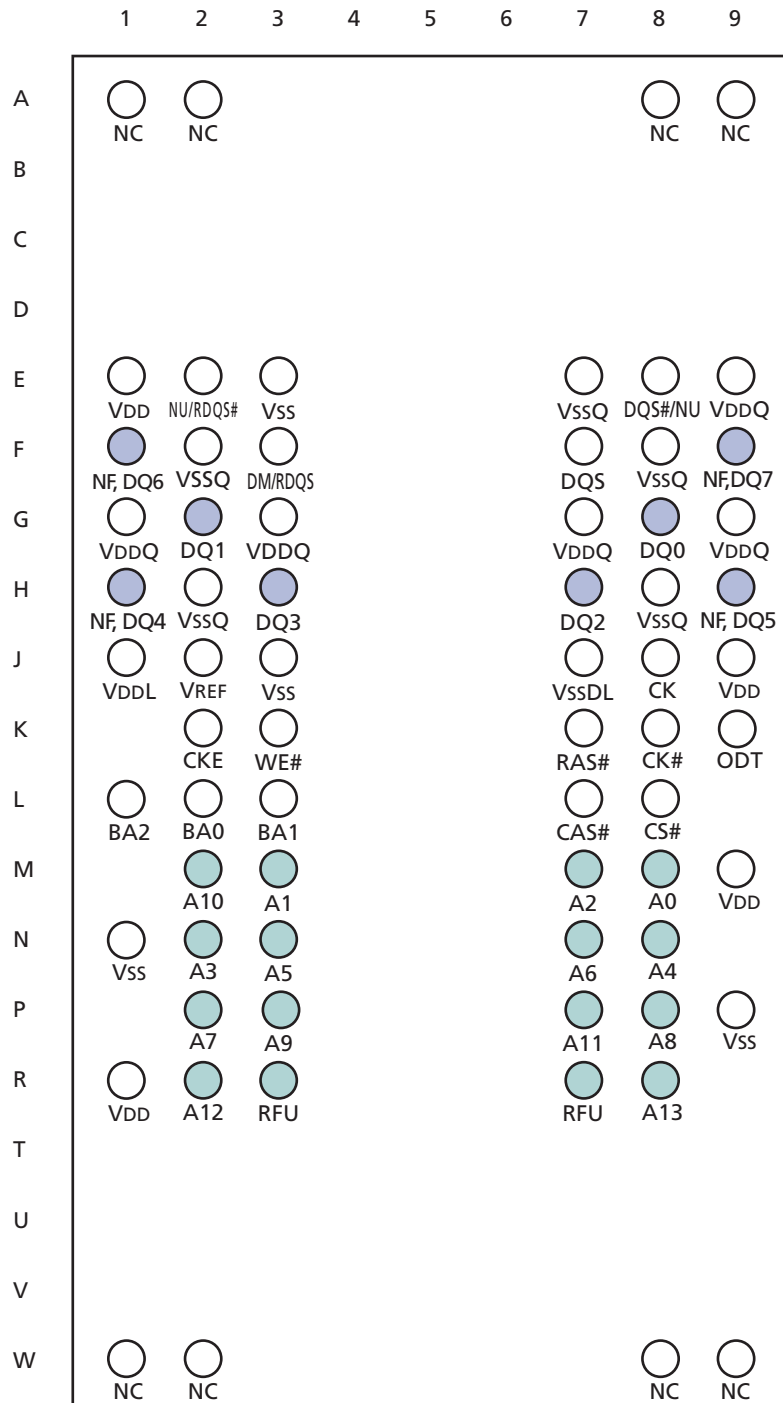

Table 3: 84-/68-Ball Descriptions – 256 Meg x 4, 128 Meg x 8, 64 Meg x 16

| x16 Ball Number | x4, x8 Ball Number | Symbol | Type | Description |
|--|--|--|-------|---|
| K9 | K9 | ODT | Input | On-die termination: ODT (registered HIGH) enables termination resistance internal to the DDR2 SDRAM. When enabled, ODT is only applied to each of the following balls: DQ0–DQ15, LDM, UDM, LDQS, LDQS#, UDQS, and UDQS# for the x16; DQ0–DQ7, DQS, DQS#, RDQS, RDQS#, and DM for the x8; DQ0–DQ3, DQS, DQS#, and DM for the x4. The ODT input will be ignored if disabled via the LOAD MODE command. |
| J8, K8 | J8, K8 | CK, CK# | Input | Clock: CK and CK# are differential clock inputs. All address and control input signals are sampled on the crossing of the positive edge of CK and negative edge of CK#. Output data (DQs and DQS/DQS#) is referenced to the crossings of CK and CK#. |
| K2 | K2 | CKE | Input | Clock enable: CKE (registered HIGH) activates and CKE (registered LOW) deactivates clocking circuitry on the DDR2 SDRAM. The specific circuitry that is enabled/disabled is dependent on the DDR2 SDRAM configuration and operating mode. CKE LOW provides precharge power-down mode and SELF REFRESH operation (all banks idle), or active power-down (row active in any bank). CKE is synchronous for power-down entry, power-down exit, output disable, and for self refresh entry. CKE is asynchronous for SELF REFRESH exit. Input buffers (excluding CK, CK#, CKE, and ODT) are disabled during power-down. Input buffers (excluding CKE) are disabled during self refresh. CKE is an SSTL_18 input but will detect a LVCMOS LOW level once VDD is applied during first power-up. After VREF has become stable during the power on and initialization sequence, it must be maintained for proper operation of the CKE receiver. For proper SELF REFRESH operation, VREF must be maintained. |
| L8 | L8 | CS# | Input | Chip select: CS# enables (registered LOW) and disables (registered HIGH) the command decoder. All commands are masked when CS# is registered HIGH. CS# provides for external bank selection on systems with multiple ranks. CS# is considered part of the command code. |
| K7, L7, K3 | K7, L7, K3 | RAS#, CAS#, WE# | Input | Command inputs: RAS#, CAS#, and WE# (along with CS#) define the command being entered. |
| F3, B3 | F3 | LDM, UDM (DM) | Input | Input data mask: DM is an input mask signal for write data. Input data is masked when DM is concurrently sampled HIGH during a WRITE access. DM is sampled on both edges of DQS. Although DM balls are input-only, the DM loading is designed to match that of DQ and DQS balls. LDM is DM for lower byte DQ0–DQ7 and UDM is DM for upper byte DQ8–DQ15. |
| L2, L3, L1 | L2, L3, L1 | BA0–BA2 | Input | Bank address inputs: BA0–BA2 define to which bank an ACTIVE, READ, WRITE, or PRECHARGE command is being applied. BA0–BA2 define which mode register, including MR, EMR, EMR(2), and EMR(3), is loaded during the LOAD MODE command. |
| M8, M3, M7, N2, N8, N3, N7, P2, P8, P3, M2, P7, R2 | M8, M3, M7, N2, N8, N3, N7, P2, P8, P3, M2, P7, R2, R8 | A0–A2, A3–A5, A6–A7, A8–A10, A11–A12, A13 (x4, x8) | Input | Address inputs: Provide the row address for ACTIVE commands, and the column address and auto precharge bit (A10) for READ/WRITE commands, to select one location out of the memory array in the respective bank. A10 sampled during a PRECHARGE command determines whether the PRECHARGE applies to one bank (A10 LOW, bank selected by BA2–BA0) or all banks (A10 HIGH). The address inputs also provide the op-code during a LOAD MODE command. |

Table 3: 84-/68-Ball Descriptions – 256 Meg x 4, 128 Meg x 8, 64 Meg x 16 (Continued)

| x16 Ball Number | x4, x8 Ball Number | Symbol | Type | Description |
|--|--------------------------------|--|--------|--|
| G8, G2, H7, H3, H1, H9, F1, F9, C8, C2, D7, D3, D1, D9, B1, B9 | – | DQ0–DQ3, DQ4–DQ7, DQ8–DQ10, DQ11–DQ13, DQ14–DQ15 | I/O | Data input/output: Bidirectional data bus for 64 Meg x 16. |
| – | G8, G2, H7, H3, H1, H9, F1, F9 | DQ0–DQ3, DQ4–DQ7 | I/O | Data input/output: Bidirectional data bus for 128 Meg x 8. |
| – | G8, G2, H7, H3 | DQ0–DQ2, DQ3 | I/O | Data input/output: Bidirectional data bus for 256 Meg x 4. |
| B7, A8 | – | UDQS, UDQS# | I/O | Data strobe for upper byte: Output with read data, input with write data for source synchronous operation. Edge-aligned with read data, center-aligned with write data. UDQS# is only used when differential data strobe mode is enabled via the LOAD MODE command. |
| F7, E8 | – | LDQS, LDQS# | I/O | Data strobe for lower byte: Output with read data, input with write data for source synchronous operation. Edge-aligned with read data, center-aligned with write data. LDQS# is only used when differential data strobe mode is enabled via the LOAD MODE command. |
| – | F7, E8 | DQS, DQS# | I/O | Data strobe: Output with read data, input with write data for source synchronous operation. Edge-aligned with read data, center-aligned with write data. DQS# is only used when differential data strobe mode is enabled via the LOAD MODE command. |
| – | F3, E2 | RDQS, RDQS# | Output | Redundant data strobe for 128 Meg x 8 only. RDQS is enabled/disabled via the LOAD MODE command to the extended mode register (EMR). When RDQS is enabled, RDQS is output with read data only and is ignored during write data. When RDQS is disabled, ball F3 becomes data mask (see DM ball). RDQS# is only used when RDQS is enabled and differential data strobe mode is enabled. |
| A1, E1, J9, M9, R1 | E1, J9, M9, R1 | VDD | Supply | Power supply: 1.8V ±0.1V. |
| J1 | J1 | VDDL | Supply | DLL power supply: 1.8V ±0.1V. |
| A9, C1, C3, C7, C9, E9, G1, G3, G7, G9 | E9, G1, G3, G7, G9 | VDDQ | Supply | DQ power supply: 1.8V ±0.1V. Isolated on the device for improved noise immunity. |
| J2 | J2 | VREF | Supply | SSTL_18 reference voltage. |
| A3, E3, J3, N1, P9 | J3, E3, N1, P9 | VSS | Supply | Ground. |
| J7 | J7 | VSSDL | Supply | DLL ground. Isolated on the device from VSS and VSSQ. |
| A7, B2, B8, D2, D8, E7, F2, F8, H2, H8 | E7, F2, F8, H2, H8 | VSSQ | Supply | DQ ground. Isolated on the device for improved noise immunity. |
| A2, E2 | W1, W2, W8, W9, A1, A2, A8, A9 | NC | – | No connect: These balls should be left unconnected. |
| A8, E8 | – | NU | – | Not used: Not used only on x16. If EMR[E10] = 0, A8 and E8 are UDQS# and LDQS#. If EMR[E10] = 1, then A8 and E8 are not used. |
| – | E2, E8 | NU | – | Not used: Not used only on x8. If EMR[E10] = 0, E2 and E8 are RDQS# and DQS#. If EMR[E10] = 1, then E2 and E8 are not used. |
| – | F1, F9, H1, H9, E2 | NF | – | Not function: Not used only on x4. These are data lines on the x8. |
| R8, R3, R7 | R3, R7 | RFU | – | Reserved for future use: Row address bits A14 (R3) and A13 (R8). |

Figure 4: 92-Ball FBGA (x16)
11mm x 19mm top (view)

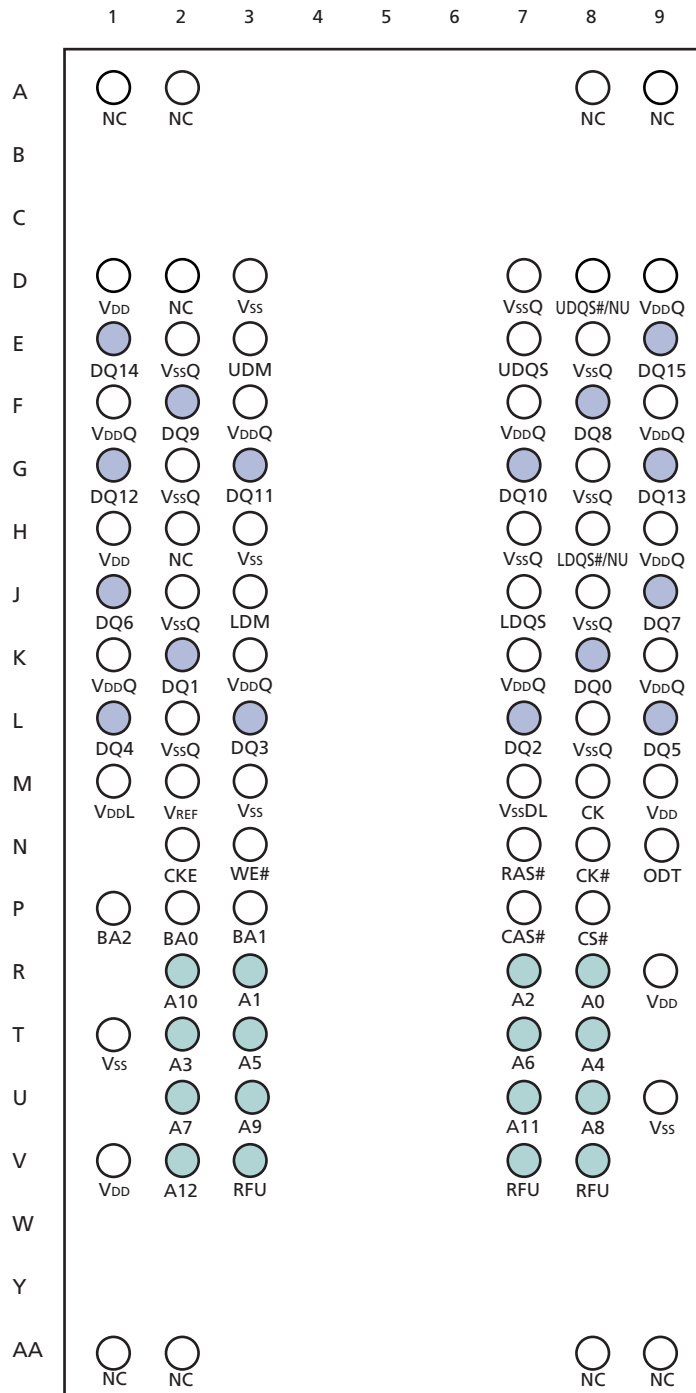

Figure 5: 92-Ball FBGA (x4/x8)
11mm x 19mm top (view)

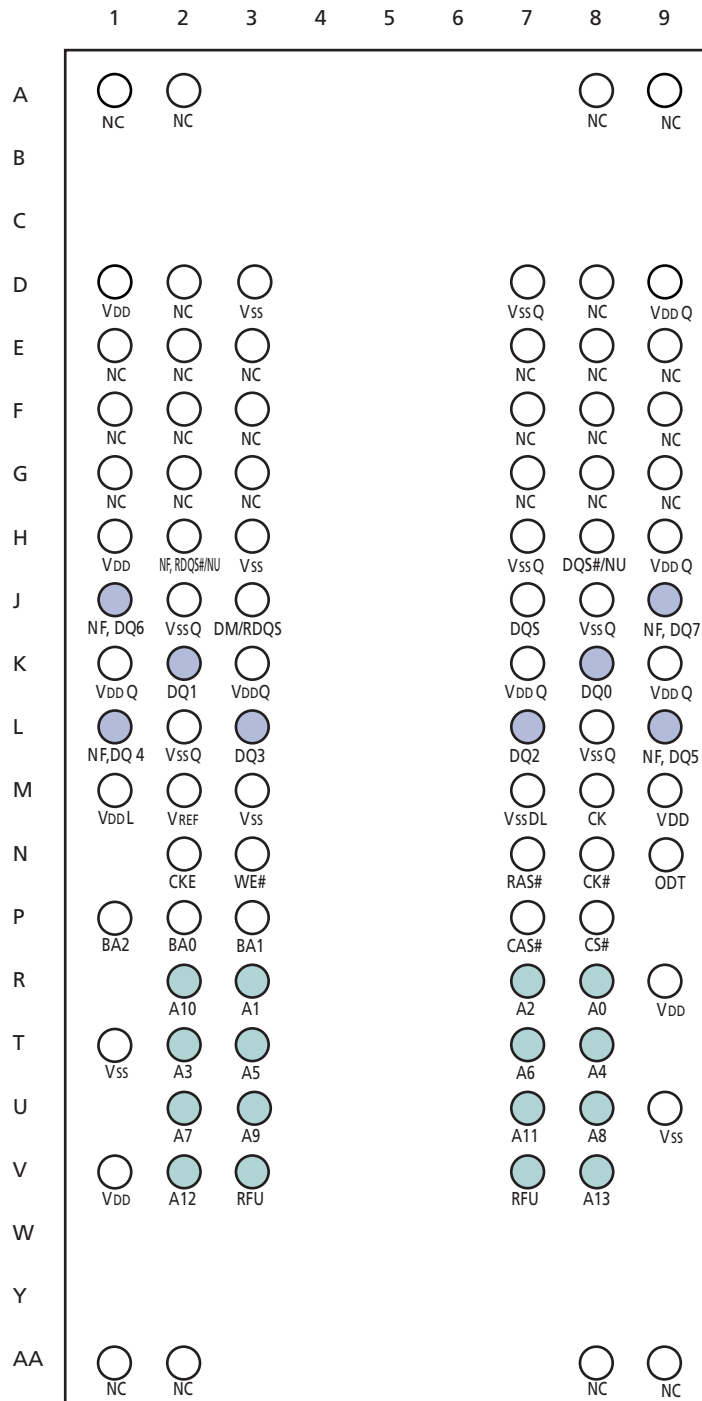

Table 4: 92-Ball Descriptions – 256 Meg x 4, 128 Meg x 8, 64 Meg x 16

| x16 Ball Number | x4, x8 Ball Number | Symbol | Type | Description |
|--|--------------------|------------------------------|-------|--|
| N9 | N9 | ODT | Input | On-die termination: ODT (registered HIGH) enables termination resistance internal to the DDR2 SDRAM. When enabled, ODT is only applied to each of the following balls: DQ0–DQ15, LDM, UDM, LDQS, LDQS#, UDQS, and UDQS# for the x16; DQ0–DQ7, DQS, DQS#, RDQS, RDQS#, and DM for the x8; DQ0–DQ3, DQS, DQS#, and DM for the x4. The ODT input will be ignored if disabled via the LOAD MODE command. |
| M8, N8 | M8, N8 | CK, CK# | Input | Clock: CK and CK# are differential clock inputs. All address and control input signals are sampled on the crossing of the positive edge of CK and negative edge of CK#. Output data (DQs and DQS/ DQS#) is referenced to the crossings of CK and CK#. |
| N2 | N2 | CKE | Input | Clock enable: CKE (registered HIGH) activates and CKE (registered LOW) deactivates clocking circuitry on the DDR2 SDRAM. The specific circuitry that is enabled/disabled is dependent on the DDR2 SDRAM configuration and operating mode. CKE LOW provides precharge power-down mode and SELF REFRESH operation (all banks idle), or active power-down (row active in any bank). CKE is synchronous for power-down entry, power-down exit, output disable, and self refresh entry. CKE is asynchronous for SELF REFRESH exit. Input buffers (excluding CK, CK#, and ODT) are disabled during power-down. Input buffers (excluding CKE) are disabled during self refresh. CKE is an SSTL_18 input but will detect a LVCMOS LOW level once VDD is applied during first power-up. After VREF has become stable during the power on and initialization sequence, it must be maintained for proper operation of the CKE receiver. For proper SELF REFRESH operation, VREF must be maintained. |
| P8 | P8 | CS# | Input | Chip select: CS# enables (registered LOW) and disables (registered HIGH) the command decoder. All commands are masked when CS# is registered HIGH. CS# provides for external bank selection on systems with multiple ranks. CS# is considered part of the command code. |
| N7, P7, N3 | N7, P7, N3 | RAS#, CAS#, WE# | Input | Command inputs: RAS#, CAS#, and WE# (along with CS#) define the command being entered. |
| J3, E3 | J3 | LDM, UDM, (DM) | Input | Input data mask: DM is an input mask signal for write data. Input data is masked when DM is concurrently sampled HIGH during a WRITE access. DM is sampled on both edges of DQS. Although DM balls are input-only, the DM loading is designed to match that of DQ and DQS balls. LDM is DM for lower byte DQ0–DQ7 and UDM is DM for upper byte DQ8–DQ15. |
| P2, P3, P1 | P2, P3, P1 | BA0–BA2 | Input | Bank address inputs: BA0–BA2 define to which bank an ACTIVE, READ, WRITE, or PRECHARGE command is being applied. BA0–BA2 define which mode register including MR, EMR, EMR(2), and EMR(3) is loaded during the LOAD MODE command. |
| R8, R3, R7, T2, T8, T3, T7, U2, U8, U3, R2, U7, V2 | – | A0–A2, A3–A6, A7–A9, A10–A12 | Input | Address inputs: Provide the row address for ACTIVE commands, and the column address and auto precharge bit (A10) for READ/ WRITE commands, to select one location out of the memory array in the respective bank. A10 sampled during a PRECHARGE command determines whether the PRECHARGE applies to one bank (A10 LOW, bank selected by BA2–BA0) or all banks (A10 HIGH). The address inputs also provide the op-code during a LOAD MODE command. |

Table 4: 92-Ball Descriptions – 256 Meg x 4, 128 Meg x 8, 64 Meg x 16

| x16 Ball Number | x4, x8 Ball Number | Symbol | Type | Description |
|--|--|--|--------|--|
| – | R8, R3, R7, T2, T8, T3, T7, U2, U8, U3, R2, U7, V2, V8 | A0–A3, A4–A7, A8–A10, A11–A13 | Input | Address inputs: Provide the row address for ACTIVE commands, and the column address and auto precharge bit (A10) for READ/ WRITE commands, to select one location out of the memory array in the respective bank. A10 sampled during a PRECHARGE command determines whether the PRECHARGE applies to one bank (A10 LOW, bank selected by BA2–BA0) or all banks (A10 HIGH). The address inputs also provide the op-code during a LOAD MODE command. |
| K8, K2, L7, L3, L1, L9, J1, J9, F8, F2, G7, G3, G1, G9, E1, E9 | – | DQ0–DQ3, DQ4–DQ7, DQ8–DQ10, DQ11–DQ13, DQ14–DQ15 | I/O | Data input/output: Bidirectional data bus for 64 Meg x 16. |
| – | K8, K2, L7, L3, L1, L9, J1, J9 | DQ0–DQ3, DQ4–DQ7 | I/O | Data input/output: Bidirectional data bus for 128 Meg x 8. |
| – | K8, K2, L7, L3 | DQ0–DQ3 | I/O | Data input/output: Bidirectional data bus for 256 Meg x 4. |
| E7, D8 | – | UDQS, UDQS# | I/O | Data strobe for upper byte: Output with read data, input with write data for source synchronous operation. Edge-aligned with read data, center-aligned with write data. UDQS# is only used when differential data strobe mode is enabled via the LOAD MODE command. |
| J7, H8 | – | LDQS, LDQS# | I/O | Data strobe for lower byte: Output with read data, input with write data for source synchronous operation. Edge-aligned with read data, center-aligned with write data. LDQS# is only used when differential data strobe mode is enabled via the LOAD MODE command. |
| – | J7, H8 | DQS, DQS# | I/O | Data strobe: Output with read data, input with write data for source synchronous operation. Edge-aligned with read data, center-aligned with write data. DQS# is only used when differential data strobe mode is enabled via the LOAD MODE command. |
| – | J3, H2 | RDQS, RDQS# | Output | Redundant data strobe for 128 Meg x 8 only. RDQS is enabled/ disabled via the LOAD MODE command to the extended mode register (EMR). When RDQS is enabled, RDQS is output with read data only and is ignored during write data. When RDQS is disabled, ball J3 becomes data mask (see DM ball). RDQS# is only used when RDQS is enabled <i>and</i> differential data strobe mode is enabled. |
| D1, H1, M9, R9, V1 | D1, H1, M9, R9, V1 | VDD | Supply | Power Supply: 1.8V ±0.1V. |
| M1 | M1 | VDDL | Supply | DLL Power supply: 1.8V ±0.1V. |
| D9, F1, F3, F7, F9, H9, K1, K3, K7, K9 | D9, H9, K1, K3, K7, K9 | VDDQ | Supply | DQ Power supply: 1.8V ±0.1V. Isolated on the device for improved noise immunity. |
| M2 | M2 | VREF | Supply | SSTL_18 reference voltage. |
| D3, H3, M3, T1, U9 | D3, H3, M3, T1, U9 | VSS | Supply | Ground. |
| M7 | M7 | VSSDL | Supply | DLL ground: Isolated on the device from VSS and VSSQ. |
| D7, E2, E8, G2, G8, H7, J2, J8, L2, L8 | D7, H7, J2, J8, L2, L8 | VSSQ | Supply | DQ ground: Isolated on the device for improved noise immunity. |

Table 4: 92-Ball Descriptions – 256 Meg x 4, 128 Meg x 8, 64 Meg x 16

| x16 Ball Number | x4, x8 Ball Number | Symbol | Type | Description |
|---|--|--------|------|---|
| A1, A2, A8, A9 D2, H2, AA1, AA2, AA8, AA9 | A1, A2, A8, A9, D2, D8, E1–E3, E7–E9, F1–F3, F7–F9, G1–G3, G7–G9, AA1, AA2, AA8, AA9 | NC | – | No connect: These balls should be left unconnected. |
| – | J1, J9, L1, L9, H2, | NF | – | No function: These balls are used as DQ4–DQ7 on the 128 Meg x8 , but are NF (no function) on the 256 Meg x 4 configuration. |
| D8, H8 | – | NU | – | Not used: Not used only on x16. If EMR[E10] = 0, D8 and H8 are UDQS# and LDQS#. If EMR[E10] = 1, then D8 and H8 are not used. |
| – | H2, H8 | NU | – | Not used: Not used only on x8. If EMR[E10] = 0, H2 and H8 are RDQS# and DQS#. If EMR[E10] = 1, then H2 and H8 are not used. |
| V3, V7, V8 | V3, V7 | RFU | – | Reserved for future use: Row address bits A13 (V8), A14(V3), and A15(V7) are reserved. |

Functional Description

The 1Gb DDR2 SDRAM is a high-speed CMOS dynamic random access memory containing 1,073,741,824 bits. The 1Gb DDR2 SDRAM is internally configured as an 8-bank DRAM.

The 1Gb DDR2 SDRAM uses a double data rate architecture to achieve high-speed operation. The DDR2 architecture is essentially a $4n$ -prefetch architecture, with an interface designed to transfer two data words per clock cycle at the I/O balls. A single read or write access for the 1Gb DDR2 SDRAM consists of a single $4n$ -bit-wide, one-clock-cycle data transfer at the internal DRAM core and four corresponding n -bit-wide, one-half-clock-cycle data transfers at the I/O balls.

Prior to normal operation, the DDR2 SDRAM must be initialized. The following sections provide detailed information covering device initialization, register definition, command descriptions, and device operation.

Figure 9 on page 20 shows a simplified state diagram to provide the basic command flow. It is not comprehensive and does not identify all timing requirements or possible command restrictions.

Figure 6: Functional Block Diagram – 64 Meg x 16

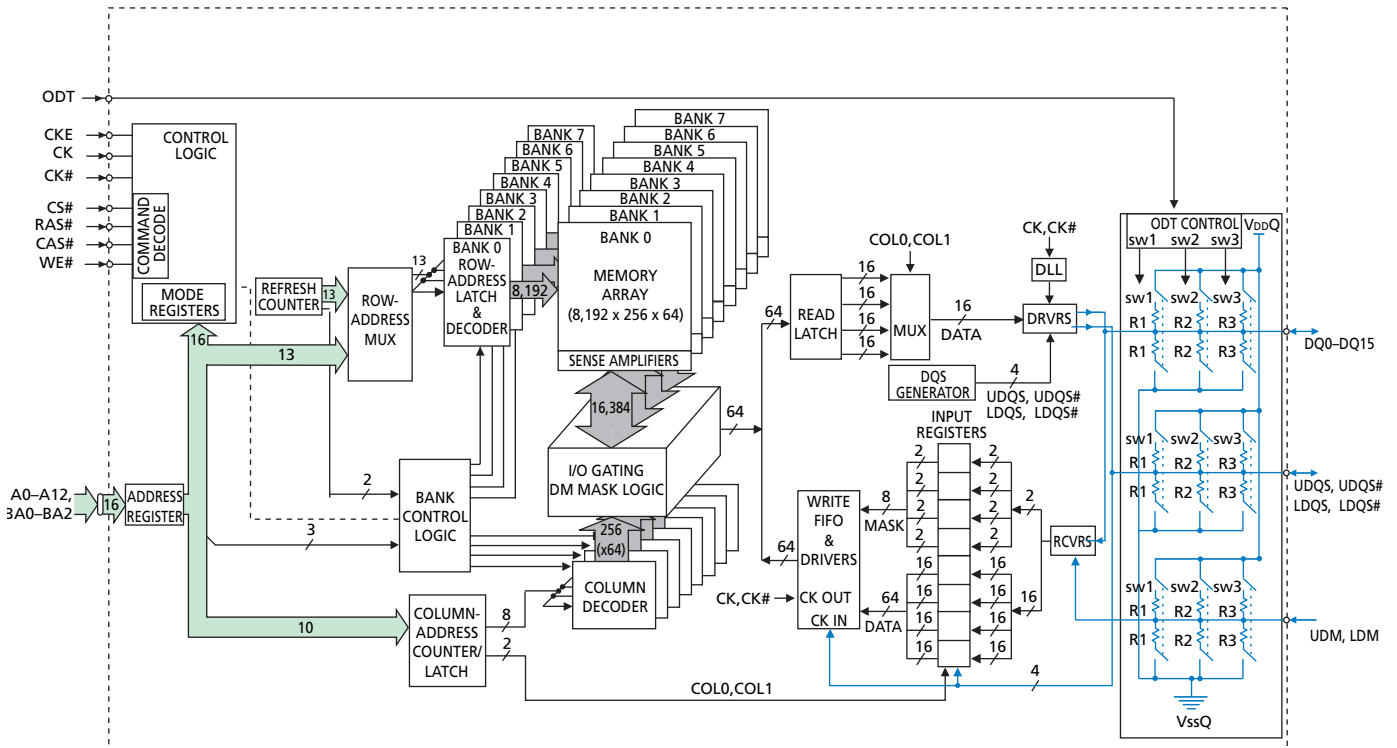

Figure 7: Functional Block Diagram – 128 Meg x 8

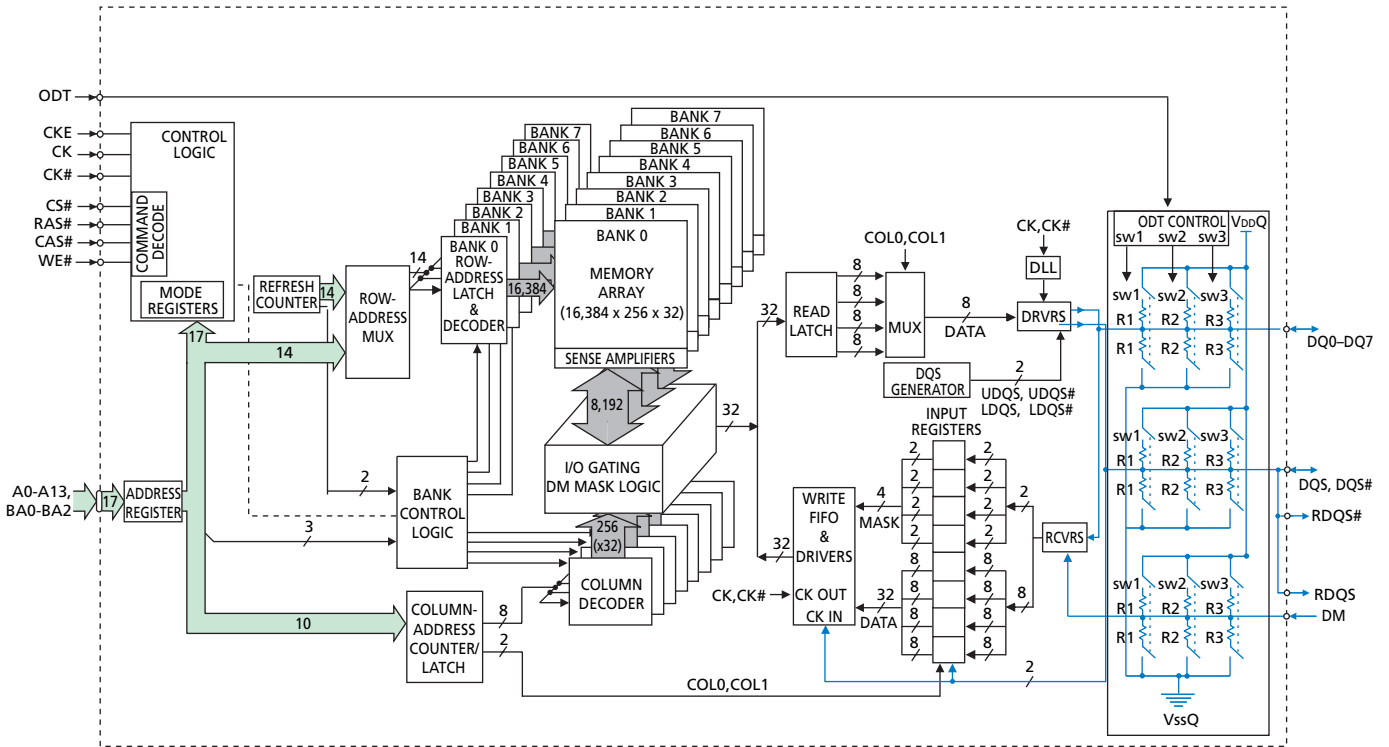
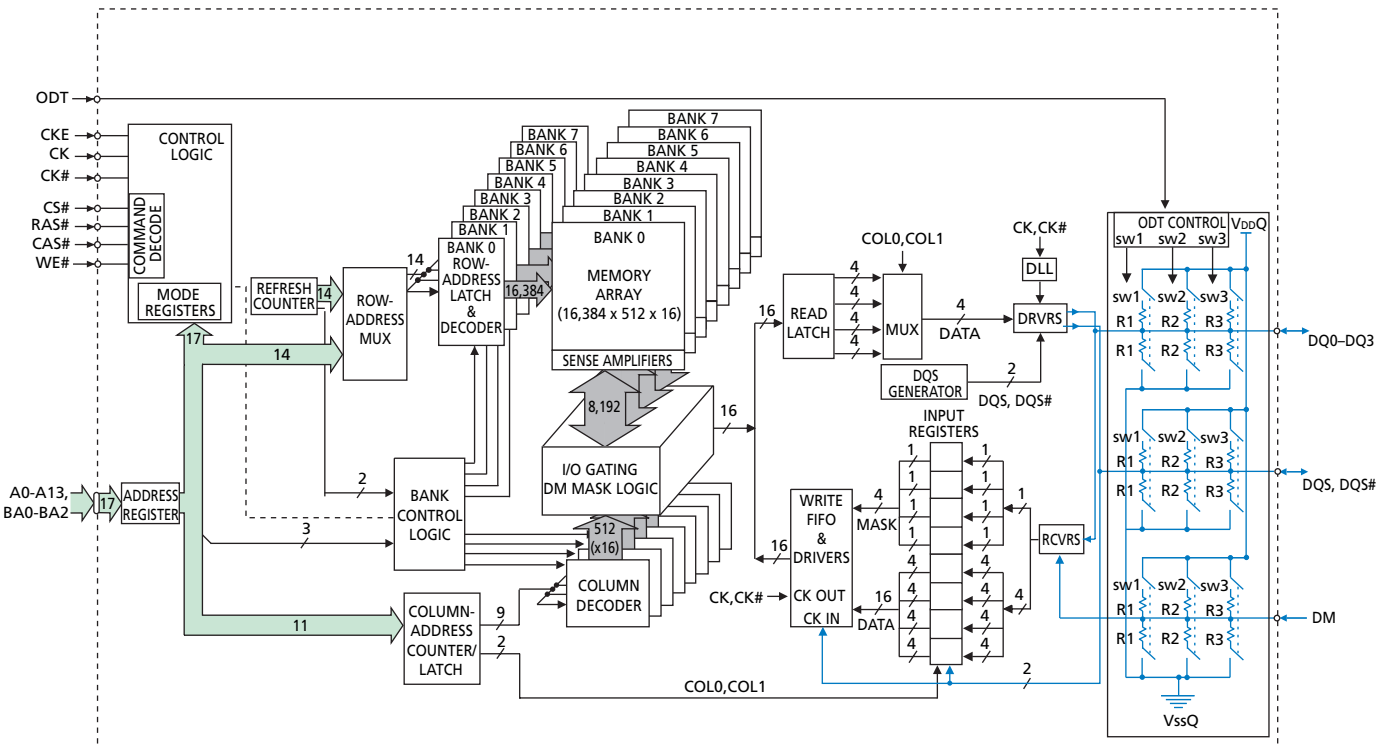

Figure 8: Functional Block Diagram – 256 Meg x 4



State Diagram

Figure 9 shows a simplified state diagram to provide the basic command flow. It is not comprehensive and does not identify all timing requirements or possible command restrictions.

Figure 9: Simplified State Diagram

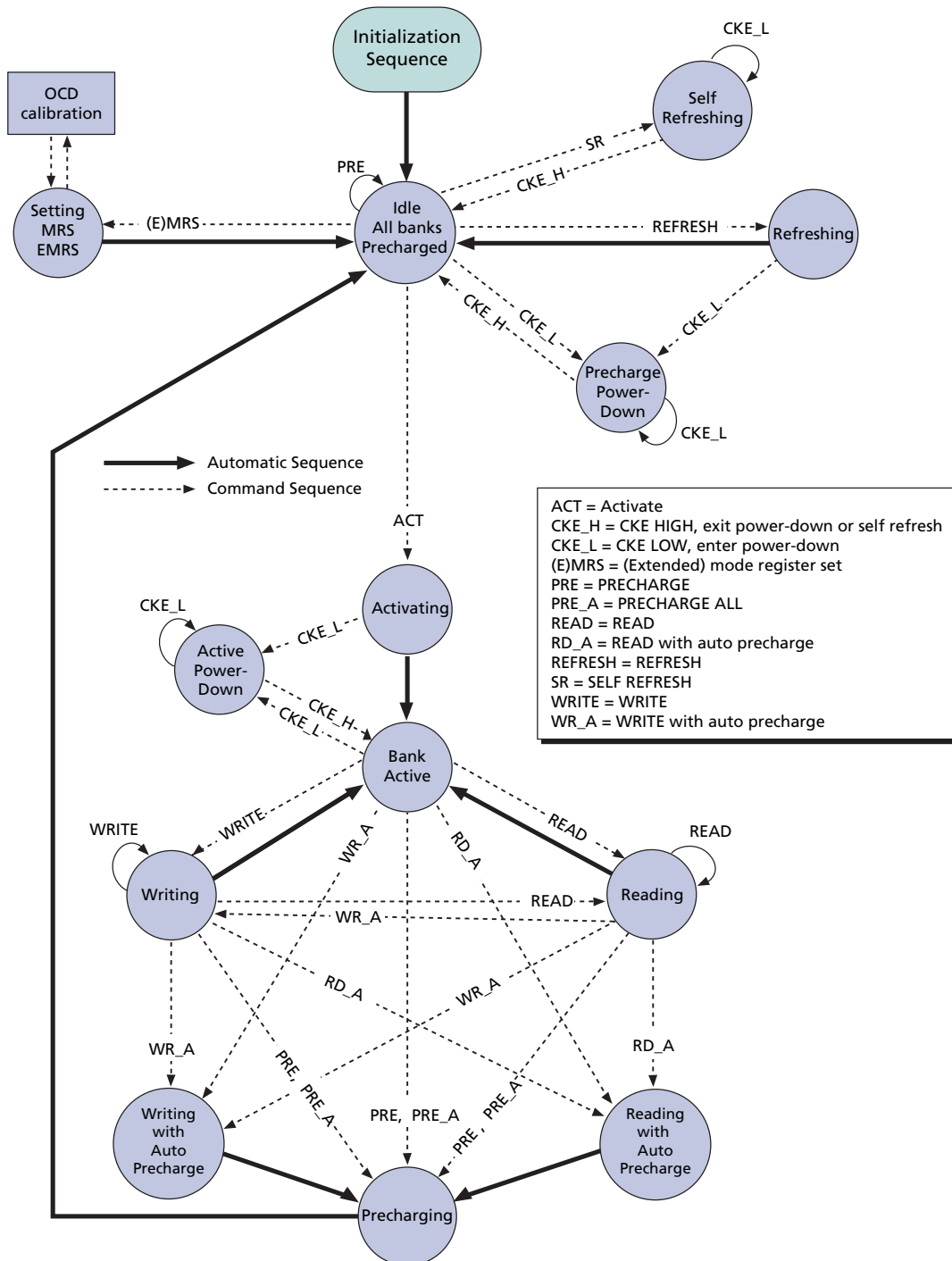

Initialization

DDR2 SDRAMs must be powered up and initialized in a predefined manner. Operational procedures those specified may result in undefined operation. Figure 10 illustrates the sequence required for initialization.

Figure 10: DDR2 Power-up and Initialization

Notes appear on page 22

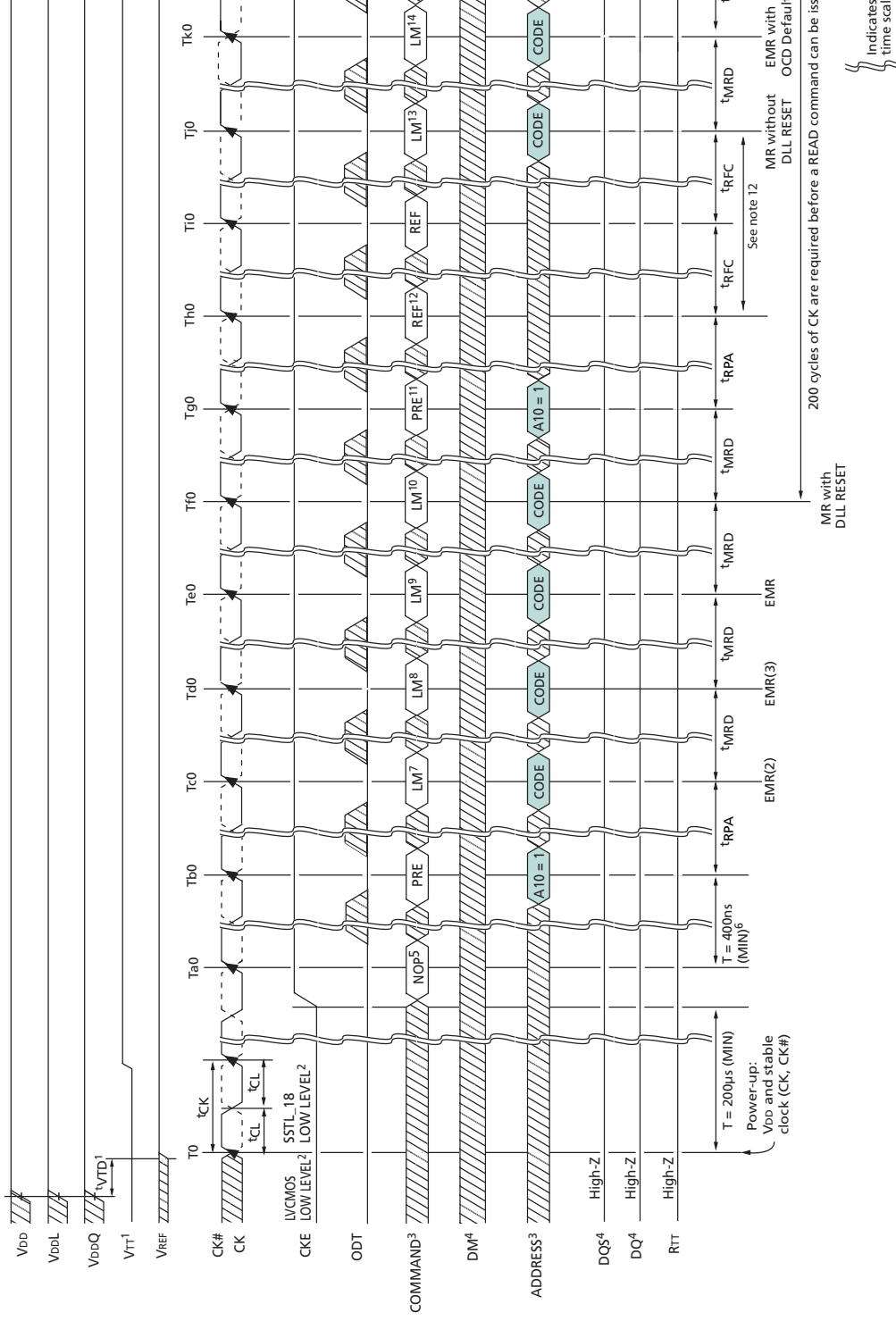

- Notes:
1. Applying power; if CKE is maintained below $0.2 \times V_{DDQ}$, outputs remain disabled. To guarantee R_{TT} (ODT resistance) is off, V_{REF} must be valid and a low level must be applied to the ODT ball (all other inputs may be undefined; I/Os and outputs must be less than V_{DDQ} during voltage ramp time to avoid DDR2 SDRAM device latch-up). V_{TT} is not applied directly to the device; however, V_{TT} should be ≥ 0 to avoid device latch-up. At least one of the following two sets of conditions (A or B) must be met to obtain a stable supply state (stable supply defined as V_{DD} , V_{DDL} , V_{DDQ} , V_{REF} , and V_{TT} are between their minimum and maximum values as stated in Table 20 on page 89):
 - A. Single power source: The V_{DD} voltage ramp from 300mV to V_{DD} (MIN) must take no longer than 200ms; during the V_{DD} voltage ramp, $|V_{DD} - V_{DDQ}| \leq 0.3V$. Once supply voltage ramping is complete (when V_{DDQ} crosses V_{DD} [MIN]), Table 20 specifications apply.
 - V_{DD} , V_{DDL} , and V_{DDQ} are driven from a single power converter output
 - V_{TT} is limited to 0.95V MAX
 - V_{REF} tracks $V_{DDQ}/2$; V_{REF} must be within $\pm 0.3V$ with respect to $V_{DDQ}/2$ during supply ramp time
 - $V_{DDQ} \geq V_{REF}$ at all times
 - B. Multiple power sources: $V_{DD} \geq V_{DDL} \geq V_{DDQ}$ must be maintained during supply voltage ramping, for both AC and DC levels, until supply voltage ramping completes (V_{DDQ} crosses V_{DD} [MIN]). Once supply voltage ramping is complete, Table 20 specifications apply.
 - Apply V_{DD} and V_{DDL} before or at the same time as V_{DDQ} ; V_{DD}/V_{DDL} voltage ramp time must be $\leq 200ms$ from when V_{DD} ramps from 300mV to V_{DD} (MIN)
 - Apply V_{DDQ} before or at the same time as V_{TT} ; the V_{DDQ} voltage ramp time from when V_{DD} (MIN) is achieved to when V_{DDQ} (MIN) is achieved must be $\leq 500ms$; while V_{DD} is ramping, current can be supplied from V_{DD} through the device to V_{DDQ}
 - V_{REF} must track $V_{DDQ}/2$; V_{REF} must be within $\pm 0.3V$ with respect to $V_{DDQ}/2$ during supply ramp time; $V_{DDQ} \geq V_{REF}$ must be met at all times
 - Apply V_{TT} ; the V_{TT} voltage ramp time from when V_{DDQ} (MIN) is achieved to when V_{TT} (MIN) is achieved must be no greater than 500ms
 2. CKE uses LVCMOS input levels prior to state T0 to ensure DQs are High-Z during device power-up prior to V_{REF} being stable. After state T0, CKE is required to have SSTL₁₈ input levels. Once CKE transitions to a high level, it must stay HIGH for the duration of the initialization sequence.
 3. PRE = PRECHARGE command, LM = LOAD MODE command, MR = Mode Register, EMR = extended mode register, EMR2 = extended mode register 2, EMR3 = extended mode register 3, REF = REFRESH command, ACT = ACTIVE command, A10 = PRECHARGE ALL, CODE = desired values for mode registers (bank addresses are required to be decoded), VALID - any valid command/address, RA = row address, bank address.
 4. DM represents DM for x4, x8 configurations and UDM, LDM for x16 configuration; DQS represents DQS, DQS#, UDQS, UDQS#, LDQS, LDQS#, RDQS, RDQS# for the appropriate configuration (x4, x8, x16); DQ represents DQ0–DQ3 for x4, DQ–DQ7 for x8, and DQ0–DQ15 for x16.
 5. For a minimum of 200 μ s after stable power and clock (CK, CK#), apply NOP or DESELECT commands, then take CKE HIGH.
 6. Wait a minimum of 400ns, then issue a PRECHARGE ALL command.
 7. Issue a LOAD MODE command to the EMR(2). (To issue an EMR(2) command, provide LOW to BA2 and BA0, and provide HIGH to BA1.) Set register E7 to "0" or "1;" all others must be "0."
 8. Issue a LOAD MODE command to the EMR(3). (To issue an EMR(3) command, provide HIGH to BA0 = 1, BA1 = 1, and BA2 = 0.) Set all registers to "0."
 9. Issue a LOAD MODE command to the EMR to enable DLL. To issue a DLL ENABLE command, provide LOW to BA1, BA2, and A0; provide HIGH to BA0. Bits E7, E8, and E9 can be set to "0" or "1;" Micron recommends setting them to "0."
 10. Issue a LOAD MODE command for DLL RESET. 200 cycles of clock input is required to lock the DLL. (To issue a DLL RESET, provide HIGH to A8 and provide LOW to BA2 = BA1 = BA0 = 0.) CKE must be HIGH the entire time.
 11. Issue PRECHARGE ALL command.
 12. Issue two or more REFRESH commands.

13. Issue a LOAD MODE command with LOW to A8 to initialize device operation (i.e., to program operating parameters without resetting the DLL). To access the mode registers, BA0 = 0, BA1 = 0, BA2 = 0.
14. Issue a LOAD MODE command to the EMR to enable OCD default by setting bits E7, E8, and E9 to "1," and then setting all other desired parameters. To access the extended mode register, BA2 = 0, BA1 = 0, BA0 = 1.
15. Issue a LOAD MODE command to the EMR to enable OCD exit by setting bits E7, E8, and E9 to "0," and then setting all other desired parameters. To access the extended mode registers, BA2 = 0, BA1 = 0, BA0 = 1.
16. The DDR2 SDRAM is now initialized and ready for normal operation 200 clock cycles after the DLL RESET at Tf0.

Mode Register (MR)

The mode register is used to define the specific mode of operation of the DDR2 SDRAM. This definition includes the selection of a burst length, burst type, CAS latency, operating mode, DLL RESET, write recovery, and power-down mode, as shown in Figure 11 on page 25. Contents of the mode register can be altered by re-executing the LOAD MODE (LM) command. If the user chooses to modify only a subset of the MR variables, all variables (M0–M13 for x4 and x8 or M0–M12 for x16) must be programmed when the command is issued.

The MR is programmed via the LM command (bits BA2–BA0 = 0, 0, 0) and other bits (M13–M0 for x4 and x8, M12–M0 for x16) will retain the stored information until it is programmed again or the device loses power (except for bit M8, which is self-clearing). Reprogramming the mode register will not alter the contents of the memory array, provided it is performed correctly.

The LM command can only be issued (or reissued) when all banks are in the precharged state (idle state) and no bursts are in progress. The controller must wait the specified time t_{MRD} before initiating any subsequent operations such as an ACTIVE command. Violating either of these requirements will result in unspecified operation.

Burst Length

Burst length is defined by bits M0–M3, as shown in Figure 11 on page 25. Read and write accesses to the DDR2 SDRAM are burst-oriented, with the burst length being programmable to either four or eight. The burst length determines the maximum number of column locations that can be accessed for a given READ or WRITE command.

When a READ or WRITE command is issued, a block of columns equal to the burst length is effectively selected. All accesses for that burst take place within this block, meaning that the burst will wrap within the block if a boundary is reached. The block is uniquely selected by A2–A_i when BL = 4 and by A3–A_i when BL = 8 (where A_i is the most significant column address bit for a given configuration). The remaining (least significant) address bit(s) is (are) used to select the starting location within the block. The programmed burst length applies to both READ and WRITE bursts.

Figure 11: Mode Register (MR) Definition

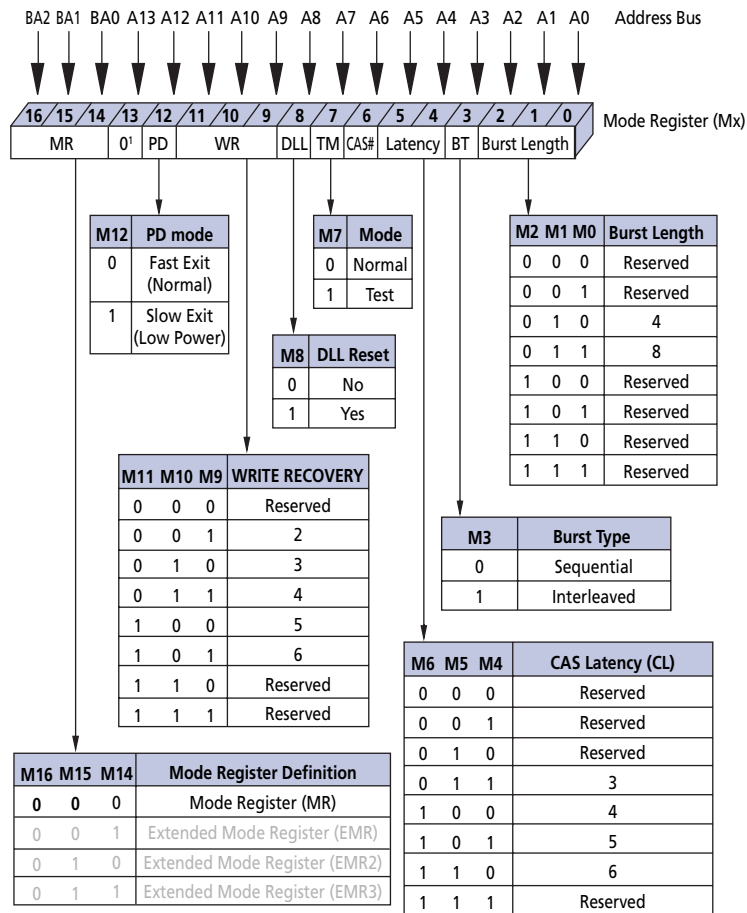

- Notes:
1. M13 (A13) is reserved for future use and must be programmed to "0." A13 is not used in x16 configuration.
 2. Not all listed CL options are supported in any individual speed grade.

Burst Type

Accesses within a given burst may be programmed to be either sequential or interleaved. The burst type is selected via bit M3, as shown in Figure 11. The ordering of accesses within a burst is determined by the burst length, the burst type, and the starting column address, as shown in Table 5 on page 26. DDR2 SDRAM supports 4-bit burst mode and 8-bit burst mode only. For 8-bit burst mode, full, interleaved address ordering is supported; however, sequential address ordering is nibble-based.

Table 5: Burst Definition

| Burst Length | Starting Column Address (A2, A1, A0) | Order of Accesses Within a Burst | |
|--------------|--------------------------------------|----------------------------------|--------------------------|
| | | Burst Type = Sequential | Burst Type = Interleaved |
| 4 | 0 0 | 0, 1, 2, 3 | 0, 1, 2, 3 |
| | 0 1 | 1, 2, 3, 0 | 1, 0, 3, 2 |
| | 1 0 | 2, 3, 0, 1 | 2, 3, 0, 1 |
| | 1 1 | 3, 0, 1, 2 | 3, 2, 1, 0 |
| 8 | 0 0 0 | 0, 1, 2, 3, 4, 5, 6, 7 | 0, 1, 2, 3, 4, 5, 6, 7 |
| | 0 0 1 | 1, 2, 3, 0, 5, 6, 7, 4 | 1, 0, 3, 2, 5, 4, 7, 6 |
| | 0 1 0 | 2, 3, 0, 1, 6, 7, 4, 5 | 2, 3, 0, 1, 6, 7, 4, 5 |
| | 0 1 1 | 3, 0, 1, 2, 7, 4, 5, 6 | 3, 2, 1, 0, 7, 6, 5, 4 |
| | 1 0 0 | 4, 5, 6, 7, 0, 1, 2, 3 | 4, 5, 6, 7, 0, 1, 2, 3 |
| | 1 0 1 | 5, 6, 7, 4, 1, 2, 3, 0 | 5, 4, 7, 6, 1, 0, 3, 2 |
| | 1 1 0 | 6, 7, 4, 5, 2, 3, 0, 1 | 6, 7, 4, 5, 2, 3, 0, 1 |
| | 1 1 1 | 7, 4, 5, 6, 3, 0, 1, 2 | 7, 6, 5, 4, 3, 2, 1, 0 |

Operating Mode

The normal operating mode is selected by issuing a command with bit M7 set to “0,” and all other bits set to the desired values, as shown in Figure 11 on page 25. When bit M7 is “1,” no other bits of the mode register are programmed. Programming bit M7 to “1” places the DDR2 SDRAM into a test mode that is only used by the manufacturer and should *not* be used. No operation or functionality is guaranteed if M7 bit is “1.”

DLL RESET

DLL RESET is defined by bit M8, as shown in Figure 11 on page 25. Programming bit M8 to “1” will activate the DLL RESET function. Bit M8 is self-clearing, meaning it returns back to a value of “0” after the DLL RESET function has been issued.

Anytime the DLL RESET function is used, 200 clock cycles must occur before a READ command can be issued to allow time for the internal clock to be synchronized with the external clock. Failing to wait for synchronization to occur may result in a violation of the t_{AC} or t_{DQSCK} parameters.

Write Recovery

Write recovery (WR) time is defined by bits M9–M11, as shown in Figure 11 on page 25. The WR register is used by the DDR2 SDRAM during WRITE with auto precharge operation. During WRITE with auto precharge operation, the DDR2 SDRAM delays the internal auto precharge operation by WR clocks (programmed in bits M9–M11) from the last data burst. An example of WRITE with auto precharge is shown in Figure 43 on page 62.

WR values of 2, 3, 4, 5, or 6 clocks may be used for programming bits M9–M11. The user is required to program the value of WR, which is calculated by dividing t_{WR} (in nanoseconds) by t_{CK} (in nanoseconds) and rounding up a noninteger value to the next integer; $WR [cycles] = t_{WR} [ns] / t_{CK} [ns]$. Reserved states should not be used as unknown operation or incompatibility with future versions may result.

Power-Down Mode

Active power-down (PD) mode is defined by bit M12, as shown in Figure 11 on page 25. PD mode allows the user to determine the active power-down mode, which determines performance versus power savings. PD mode bit M12 does not apply to precharge PD mode.

When bit M12 = 0, standard active PD mode, or “fast-exit” active PD mode, is enabled. The t^{XARD} parameter is used for fast-exit active PD exit timing. The DLL is expected to be enabled and running during this mode.

When bit M12 = 1, a lower-power active PD mode, or “slow-exit” active PD mode, is enabled. The t^{XARDS} parameter is used for slow-exit active PD exit timing. The DLL can be enabled but “frozen” during active PD mode since the exit-to-READ command timing is relaxed. The power difference expected between IDD3P normal and IDD3P low-power mode is defined in Table 45 on page 118.

CAS Latency (CL)

The CAS latency (CL) is defined by bits M4–M6, as shown in Figure 11 on page 25. CL is the delay, in clock cycles, between the registration of a READ command and the availability of the first bit of output data. The CL can be set to 3, 4, 5, or 6 clocks, depending on the speed grade option being used.

DDR2 SDRAM does not support any half-clock latencies. Reserved states should not be used as unknown operation or incompatibility with future versions may result.

DDR2 SDRAM also supports a feature called posted CAS additive latency (AL). This feature allows the READ command to be issued prior to $t^{\text{RCD}}(\text{MIN})$ by delaying the internal command to the DDR2 SDRAM by AL clocks. The AL feature is described in more detail in “Posted CAS Additive Latency (AL)” on page 31.

Examples of CL = 3 and CL = 4 are shown in Figure 12 on page 28; both assume AL = 0. If a READ command is registered at clock edge n , and the CL is m clocks, the data will be available nominally coincident with clock edge $n + m$ (this assumes AL = 0).

Figure 12: CAS Latency (CL)

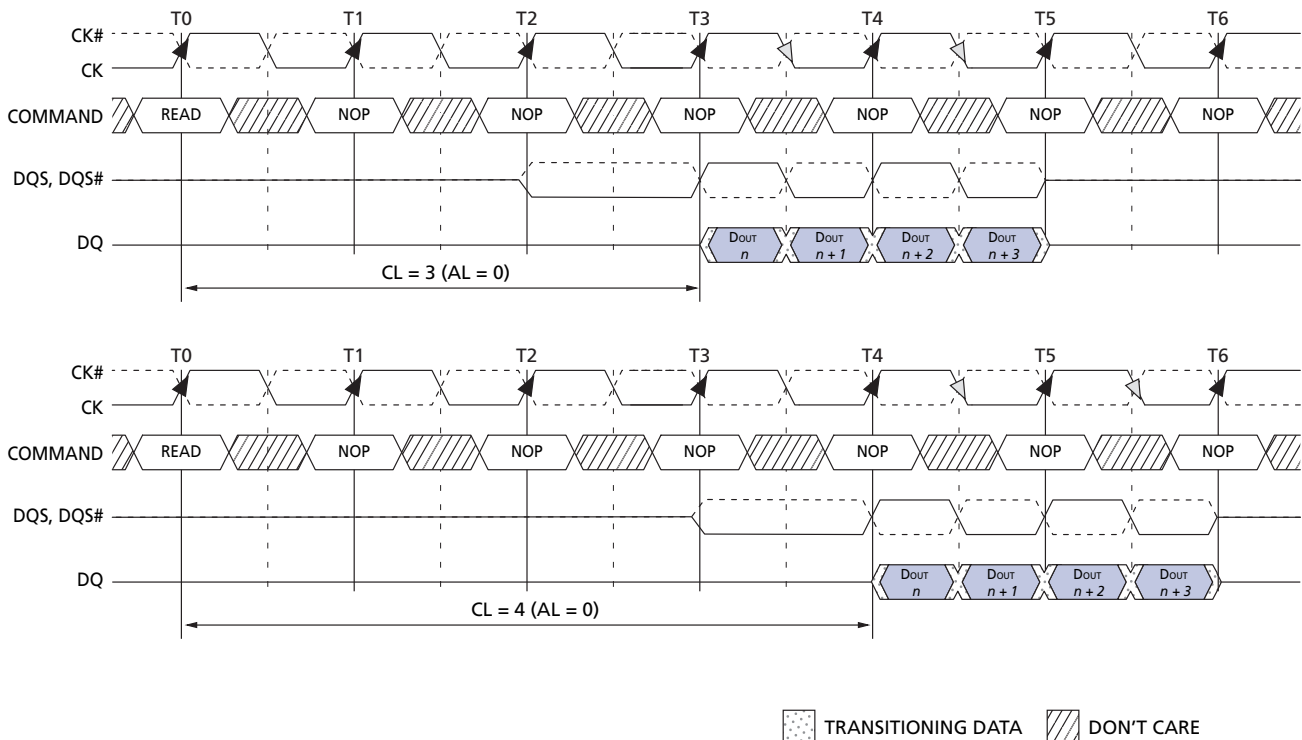

- Notes:
1. BL = 4.
 2. Posted CAS# additive latency (AL) = 0.
 3. Shown with nominal t_{AC} , t_{DQSCk} , and t_{DQSQ} .

Extended Mode Register (EMR)

The extended mode register controls functions beyond those controlled by the mode register; these additional functions are DLL enable/disable, output drive strength, on-die termination (ODT) (RTT), posted AL, off-chip driver impedance calibration (OCD), DQS# enable/disable, RDQS/RDQS# enable/disable, and output disable/enable. These functions are controlled via the bits shown in Figure 13 on page 29. The EMR is programmed via the LM command and will retain the stored information until it is programmed again or the device loses power. Reprogramming the EMR will not alter the contents of the memory array, provided it is performed correctly.

The EMR must be loaded when all banks are idle and no bursts are in progress, and the controller must wait the specified time t_{MRD} before initiating any subsequent operation. Violating either of these requirements could result in unspecified operation.

Figure 13: Extended Mode Register Definition

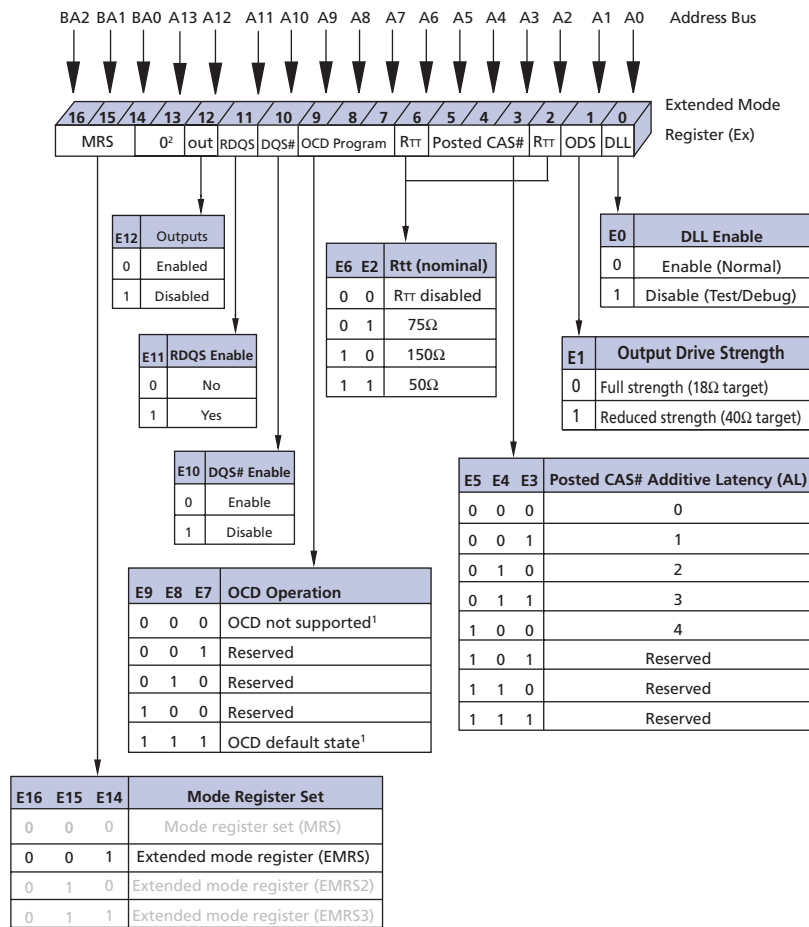

- Notes: 1. During initialization, all three bits must be set to "1" for OCD default state, then must be set to "0" before initialization is finished, as detailed in the notes on pages 22–23.
2. E13 (A13) is not used on the x16 configuration.

DLL Enable/Disable

The DLL may be enabled or disabled by programming bit E0 during the LM command, as shown in Figure 13. The DLL must be enabled for normal operation. DLL enable is required during power-up initialization and upon returning to normal operation after having disabled the DLL for the purpose of debugging or evaluation. Enabling the DLL should always be followed by resetting the DLL using the LM command.

The DLL is automatically disabled when entering SELF REFRESH operation and is automatically re-enabled and reset upon exit of SELF REFRESH operation.

Anytime the DLL is enabled (and subsequently reset), 200 clock cycles must occur before a READ command can be issued, to allow time for the internal clock to synchronize with the external clock. Failing to wait for synchronization to occur may result in a violation of the ^tAC or ^tDQSK parameters.

Output Drive Strength

The output drive strength is defined by bit E1, as shown in Figure 13 on page 29. The normal drive strength for all outputs are specified to be SSTL_18. Programming bit E1 = 0 selects normal (full strength) drive strength for all outputs. Selecting a reduced drive strength option (E1 = 1) will reduce all outputs to approximately 60 percent of the SSTL_18 drive strength. This option is intended for the support of lighter load and/or point-to-point environments.

DQS# Enable/Disable

The DQS# ball is enabled by bit E10. When E10 = 0, DQS# is the complement of the differential data strobe pair DQS/DQS#. When disabled (E10 = 1), DQS is used in a single-ended mode and the DQS# ball is disabled. When disabled, DQS# should be left floating. This function is also used to enable/disable RDQS#. If RDQS is enabled (E11 = 1) and DQS# is enabled (E10 = 0), then both DQS# and RDQS# will be enabled.

RDQS Enable/Disable

The RDQS ball is enabled by bit E11, as shown in Figure 13 on page 29. This feature is only applicable to the x8 configuration. When enabled (E11 = 1), RDQS is identical in function and timing to data strobe DQS during a READ. During a WRITE operation, RDQS is ignored by the DDR2 SDRAM.

Output Enable/Disable

The OUTPUT ENABLE function is defined by bit E12, as shown in Figure 13 on page 29. When enabled (E12 = 0), all outputs (DQs, DQS, DQS#, RDQS, RDQS#) function normally. When disabled (E12 = 1), all DDR2 SDRAM outputs (DQs, DQS, DQS#, RDQS, RDQS#) are disabled, thus removing output buffer current. The output disable feature is intended to be used during IDD characterization of read current.

On-Die Termination (ODT)

ODT effective resistance, $R_{TT} (EFF)$, is defined by bits E2 and E6 of the EMR, as shown in Figure 13 on page 29. The ODT feature is designed to improve signal integrity of the memory channel by allowing the DDR2 SDRAM controller to independently turn on/off ODT for any or all devices. R_{TT} effective resistance values of 50 Ω , 75 Ω , and 150 Ω are selectable and apply to each DQ, DQS/DQS#, RDQS/RDQS#, UDQS/UDQS#, LDQS/LDQS#, DM, and UDM/LDM signals. Bits (E6, E2) determine what ODT resistance is enabled by turning on/off “sw1,” “sw2,” or “sw3.” The ODT effective resistance value is selected by enabling switch “sw1,” which enables all R1 values that are 150 Ω each, enabling an effective resistance of 75 Ω ($R_{TT2} (EFF) = R2/2$). Similarly, if “sw2” is enabled, all R2 values that are 300 Ω each, enable an effective ODT resistance of 150 Ω ($R_{TT2} (EFF) = R2/2$). Switch “sw3” enables R1 values of 100 Ω , enabling effective resistance of 50 Ω . Reserved states should not be used, as unknown operation or incompatibility with future versions may result.

The ODT control ball is used to determine when $R_{TT} (EFF)$ is turned on and off, assuming ODT has been enabled via bits E2 and E6 of the EMR. The ODT feature and ODT input ball are only used during active, active power-down (both fast-exit and slow-exit modes), and precharge power-down modes of operation. ODT must be turned off prior to entering self refresh. During power-up and initialization of the DDR2 SDRAM, ODT should be disabled until issuing the EMR command to enable the ODT feature, at

which point the ODT ball will determine the t_{RT} (EFF) value. Any time the EMR enables the ODT function, ODT may not be driven HIGH until eight clocks after the EMR has been enabled. See “ODT Timing” on page 79 for ODT timing diagrams.

Off-Chip Driver (OCD) Impedance Calibration

The OFF-CHIP DRIVER function is no longer supported and must be set to the default state. See “Initialization” on page 21 for proper setting of OCD defaults.

Posted CAS Additive Latency (AL)

Posted CAS additive latency (AL) is supported to make the command and data bus efficient for sustainable bandwidths in DDR2 SDRAM. Bits E3–E5 define the value of AL, as shown in Figure 13 on page 29. Bits E3–E5 allow the user to program the DDR2 SDRAM with an inverse AL of 0, 1, 2, 3, or 4 clocks. Reserved states should not be used as unknown operation or incompatibility with future versions may result.

In this operation, the DDR2 SDRAM allows a READ or WRITE command to be issued prior to t_{RCD} (MIN) with the requirement that $AL \leq t_{RCD}$ (MIN). A typical application using this feature would set $AL = t_{RCD}$ (MIN) - $1 \times t_{CK}$. The READ or WRITE command is held for the time of the AL before it is issued internally to the DDR2 SDRAM device. RL is controlled by the sum of AL and CL; $RL = AL + CL$. Write latency (WL) is equal to RL minus one clock; $WL = AL + CL - 1 \times t_{CK}$. An example of RL is shown in Figure 14. An example of a WL is shown in Figure 15 on page 32.

Figure 14: READ Latency

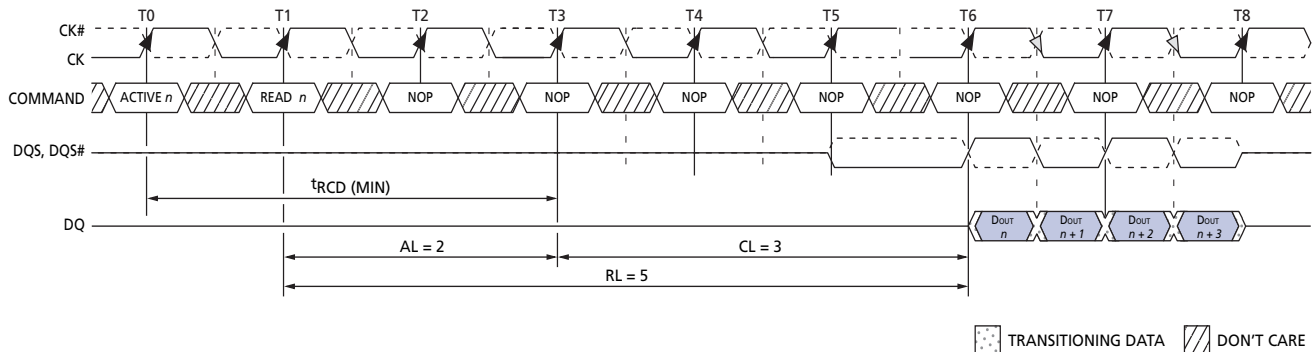

- Notes:
1. BL = 4.
 2. Shown with nominal t_{AC} , t_{DQ5CK} , and t_{DQ5Q} .
 3. CL = 3.
 4. AL = 2.
 5. $RL = AL + CL = 5$.

Figure 15: WRITE Latency

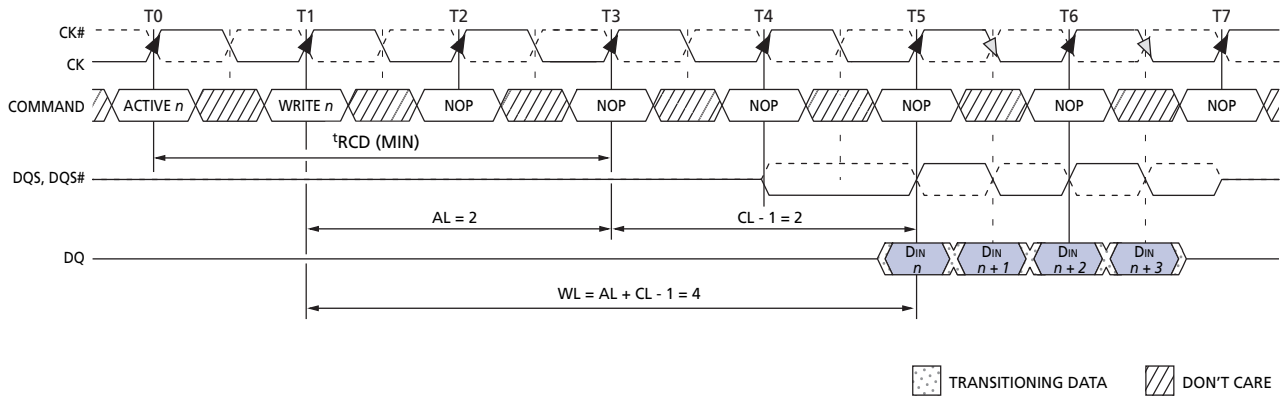

- Notes:
1. BL = 4.
 2. CL = 3.
 3. AL = 2.
 4. WL = AL + CL - 1 = 4.

Extended Mode Register 2

The extended mode register 2 (EMR2) controls functions beyond those controlled by the mode register. Currently all bits in EMR2 are reserved, except for E7, which is for commercial or high-temperature operations, as shown in Figure 16. The EMR2 is programmed via the LM command and will retain the stored information until it is programmed again or the device loses power. Reprogramming the EMR will not alter the contents of the memory array, provided it is performed correctly.

Bit E7 (A7) must be programmed as “1” to provide a faster refresh rate on IT devices if the TCASE exceeds 85°C.

EMR2 must be loaded when all banks are idle and no bursts are in progress, and the controller must wait the specified time ^tMRD before initiating any subsequent operation. Violating either of these requirements could result in unspecified operation.

Figure 16: Extended Mode Register 2 (EMR2) Definition

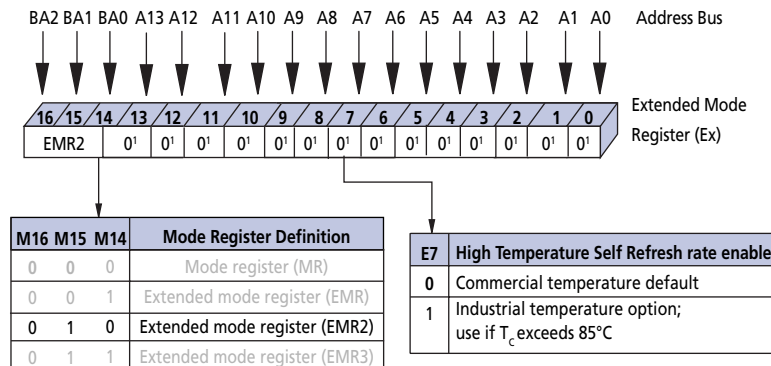

- Notes:
1. E13 (A13)–E8 (A8) and E6 (A6)–E0 (A0) are reserved for future use and must all be programmed to “0.” A13 is not used in x16 configuration.

Extended Mode Register 3

The extended mode register 3 (EMR3) controls functions beyond those controlled by the mode register. Currently all bits in EMR3 are reserved, as shown in Figure 17 on page 33. The EMR3 is programmed via the LM command and will retain the stored information until it is programmed again or the device loses power. Reprogramming the EMR will not alter the contents of the memory array, provided it is performed correctly.

EMR3 must be loaded when all banks are idle and no bursts are in progress, and the controller must wait the specified time ^tMRD before initiating any subsequent operation. Violating either of these requirements could result in unspecified operation.

Figure 17: Extended Mode Register 3 (EMR3) Definition

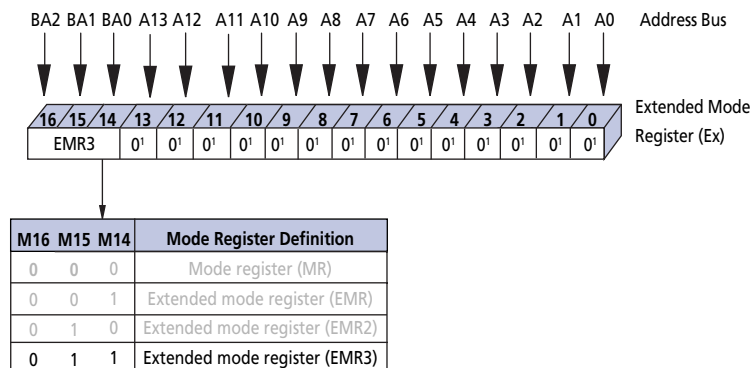

- Notes: 1. E13 (A13)–E0 (A0) are reserved for future use and must all be programmed to “0.” A13 is not used in x16 configuration.

Command Truth Tables

The following tables provide a quick reference of DDR2 SDRAM available commands, including CKE power-down modes and bank-to-bank commands.

Table 6: Truth Table – DDR2 Commands

Notes: 1, 5, and 6 apply to all

| Function | CKE | | CS# | RAS# | CAS# | WE# | BA2 BA1 BA0 | A13, A12, A11 | A10 | A9–A0 | Notes |
|---------------------------|----------------|---------------|-----|------|------|-----|-------------------|---------------------|-----|----------------|-------|
| | Previous Cycle | Current Cycle | | | | | | | | | |
| LOAD MODE | H | H | L | L | L | L | BA | OP Code | | | 2 |
| REFRESH | H | H | L | L | L | H | X | X | X | X | |
| SELF REFRESH entry | H | L | L | L | L | H | X | X | X | X | |
| SELF REFRESH exit | L | H | H | X | X | X | X | X | X | X | 7 |
| | | | L | H | H | H | | | | | |
| Single bank PRECHARGE | H | H | L | L | H | L | BA | X | L | X | 2 |
| All banks PRECHARGE | H | H | L | L | H | L | X | X | H | X | |
| Bank activate | H | H | L | L | H | H | BA | Row Address | | | |
| WRITE | H | H | L | H | L | L | BA | Column Address | L | Column Address | 2, 3 |
| WRITE with auto precharge | H | H | L | H | L | L | BA | Column Address | H | Column Address | 2, 3 |
| READ | H | H | L | H | L | H | BA | Column Address | L | Column Address | 2, 3 |
| READ with auto precharge | H | H | L | H | L | H | BA | Column Address | H | Column Address | 2, 3 |
| NO OPERATION | H | X | L | H | H | H | X | X | X | X | |
| Device DESELECT | H | X | H | X | X | X | X | X | X | X | |
| Power-down entry | H | L | H | X | X | X | X | X | X | X | 4 |
| | | | L | H | H | H | | | | | |
| Power-down exit | L | H | H | X | X | X | X | X | X | X | 4 |
| | | | L | H | H | H | | | | | |

- Notes:
1. All DDR2 SDRAM commands are defined by states of CS#, RAS#, CAS#, WE#, and CKE at the rising edge of the clock.
 2. Bank addresses (BA) BA0–BA2 determine which bank is to be operated upon. BA during a LM command selects which mode register is programmed.
 3. Burst reads or writes at BL = 4 cannot be terminated or interrupted. See Figure 25 on page 45 and Figure 39 on page 58 for other restrictions and details.
 4. The power-down mode does not perform any REFRESH operations. The duration of power-down is limited by the refresh requirements outlined in the AC parametric section.
 5. The state of ODT does not affect the states described in this table. The ODT function is not available during self refresh. See “ODT Timing” on page 79 for details.
 6. “X” means “H or L” (but a defined logic level).
 7. SELF REFRESH exit is asynchronous.

Table 7: Truth Table – Current State Bank *n* – Command to Bank *n*

Notes: 1–6; notes appear below and on next page

| Current State | CS# | RAS# | CAS# | WE# | Command/Action | Notes |
|---------------------------------|-----|------|------|-----|---|-------|
| Any | H | X | X | X | DESELECT (NOP/continue previous operation) | |
| | L | H | H | H | NO OPERATION (NOP/continue previous operation) | |
| Idle | L | L | H | H | ACTIVE (select and activate row) | |
| | L | L | L | H | REFRESH | 7 |
| | L | L | L | L | LOAD MODE | 7 |
| Row active | L | H | L | H | READ (select column and start READ burst) | 9 |
| | L | H | L | L | WRITE (select column and start WRITE burst) | 9 |
| | L | L | H | L | PRECHARGE (deactivate row in bank or banks) | 8 |
| Read (auto-precharge Disabled) | L | H | L | H | READ (select column and start new READ burst) | 9 |
| | L | H | L | L | WRITE (select column and start WRITE burst) | 9, 10 |
| | L | L | H | L | PRECHARGE (start PRECHARGE) | 8 |
| Write (auto-precharge disabled) | L | H | L | H | READ (select column and start READ burst) | 9 |
| | L | H | L | L | WRITE (select column and start new WRITE burst) | 9 |
| | L | L | H | L | PRECHARGE (start PRECHARGE) | 8 |

- Notes:
- This table applies when $CKEn - 1$ was HIGH and $CKEn$ is HIGH and after t_{XSNR} has been met (if the previous state was self refresh).
 - This table is bank-specific, except where noted (the current state is for a specific bank and the commands shown are those allowed to be issued to that bank when in that state). Exceptions are covered in the notes below.
 - Current state definitions:
 - Idle: The bank has been precharged, t_{RP} has been met, and any READ burst is complete.
 - Row active: A row in the bank has been activated, and t_{RCD} has been met. No data bursts/ accesses and no register accesses are in progress.
 - Read: A READ burst has been initiated, with auto precharge disabled, and has not yet terminated.
 - Write: A WRITE burst has been initiated, with auto precharge disabled, and has not yet terminated.
 - The following states must not be interrupted by a command issued to the same bank. Issue DESELECT or NOP commands, or allowable commands to the other bank, on any clock edge occurring during these states. Allowable commands to the other bank are determined by its current state and this table, and according to Table 8 on page 37.
 - Precharging: Starts with registration of a PRECHARGE command and ends when t_{RP} is met. Once t_{RP} is met, the bank will be in the idle state.
 - Read with auto precharge enabled: Starts with registration of a READ command with auto precharge enabled and ends when t_{RP} has been met. Once t_{RP} is met, the bank will be in the idle state.
 - Row activating: Starts with registration of an ACTIVE command and ends when t_{RCD} is met. Once t_{RCD} is met, the bank will be in the "row active" state.
 - Write with auto precharge enabled: Starts with registration of a WRITE command with auto precharge enabled and ends when t_{RP} has been met. Once t_{RP} is met, the bank will be in the idle state.

5. The following states must not be interrupted by any executable command (DESELECT or NOP commands must be applied on each positive clock edge during these states):
 - Refreshing: Starts with registration of a REFRESH command and ends when t_{RFC} is met. Once t_{RFC} is met, the DDR2 SDRAM will be in the all banks idle state.
 - Accessing mode register: Starts with registration of the LM command and ends when t_{MRD} has been met. Once t_{MRD} is met, the DDR2 SDRAM will be in the all banks idle state.
 - Precharging all: Starts with registration of a PRECHARGE ALL command and ends when t_{RP} is met. Once t_{RP} is met, all banks will be in the idle state.
6. All states and sequences not shown are illegal or reserved.
7. Not bank-specific; requires that all banks are idle and bursts are not in progress.
8. May or may not be bank-specific; if multiple banks are to be precharged, each must be in a valid state for precharging.
9. READs or WRITEs listed in the Command/Action column include READs or WRITEs with auto precharge enabled and READs or WRITEs with auto precharge disabled.
10. A WRITE command may be applied after the completion of the READ burst.

Table 8: Truth Table – Current State Bank *n* – Command to Bank *m*

Notes: 1–6; notes appear below and on next page

| Current State | CS# | RAS# | CAS# | WE# | Command/Action | Notes |
|--|-----|------|------|-----|---|---------|
| Any | H | X | X | X | DESELECT (NOP/continue previous operation) | |
| | L | H | H | H | NO OPERATION (NOP/continue previous operation) | |
| Idle | X | X | X | X | Any command otherwise allowed to bank <i>m</i> | |
| Row Activating, Active, or Precharging | L | L | H | H | ACTIVE (select and activate row) | |
| | L | H | L | H | READ (select column and start READ burst) | 7 |
| | L | H | L | L | WRITE (select column and start WRITE burst) | 7 |
| | L | L | H | L | PRECHARGE | |
| Read (auto precharge disabled) | L | L | H | H | ACTIVE (select and activate row) | |
| | L | H | L | H | READ (select column and start new READ burst) | 7 |
| | L | H | L | L | WRITE (select column and start WRITE burst) | 7, 9 |
| | L | L | H | L | PRECHARGE | |
| Write (auto precharge disabled.) | L | L | H | H | ACTIVE (select and activate row) | |
| | L | H | L | H | READ (select column and start READ burst) | 7, 8 |
| | L | H | L | L | WRITE (select column and start new WRITE burst) | 7 |
| | L | L | H | L | PRECHARGE | |
| Read (with auto-precharge) | L | L | H | H | ACTIVE (select and activate row) | |
| | L | H | L | H | READ (select column and start new READ burst) | 7, 3 |
| | L | H | L | L | WRITE (select column and start WRITE burst) | 7, 9, 3 |
| | L | L | H | L | PRECHARGE | |
| Write (with auto-precharge) | L | L | H | H | ACTIVE (select and activate row) | |
| | L | H | L | H | READ (select column and start READ burst) | 7, 3 |
| | L | H | L | L | WRITE (select column and start new WRITE burst) | 7, 3 |
| | L | L | H | L | PRECHARGE | |

- Notes:
- This table applies when CKE_{n-1} was HIGH and CKE_n is HIGH and after t_{XSNR} has been met (if the previous state was self refresh).
 - This table describes alternate bank operation, except where noted (i.e., the current state is for bank *n* and the commands shown are those allowed to be issued to bank *m*, assuming that bank *m* is in such a state that the given command is allowable). Exceptions are covered in the notes below.
 - Current state definitions:
 - Idle: The bank has been precharged, t_{RP} has been met, and any READ burst is complete.
 - Row active: A row in the bank has been activated and t_{RCD} has been met. No data bursts/ accesses and no register accesses are in progress.
 - Read: A READ burst has been initiated with auto precharge disabled, and has not yet terminated.
 - Write: A WRITE burst has been initiated, with auto precharge disabled, and has not yet terminated.

READ with auto precharge enabled/ WRITE with auto precharge enabled: The READ with auto precharge enabled or WRITE with auto precharge enabled states can each be broken into two parts: the access period and the precharge period. For READ with auto precharge, the precharge period is defined as if the same burst was executed with auto precharge disabled and then followed with the earliest possible PRECHARGE command that still accesses all of the data in the burst. For WRITE with auto precharge, the precharge period begins when t_{WR} ends, with t_{WR} measured as if auto precharge was disabled. The access period starts with registration of the command and ends where the precharge period (or t_{RP}) begins. This device supports concurrent auto precharge such that when a READ with auto precharge is enabled or a WRITE with auto precharge is enabled, any command to other banks is allowed, as long as that command does not interrupt the read or write data transfer already in process. In either case, all other related limitations apply (contention between read data and write data must be avoided).

The minimum delay from a READ or WRITE command with auto precharge enabled to a command to a different bank is summarized in Table 9:

Table 9: Minimum Delay with Auto Precharge Enabled

| From Command (Bank <i>n</i>) | To Command (Bank <i>m</i>) | Minimum Delay (with concurrent auto precharge) | Units |
|-------------------------------|------------------------------------|--|----------|
| WRITE with auto precharge | READ or READ with auto precharge | $(CL - 1) + (BL / 2) + t_{WTR}$ | t_{CK} |
| | WRITE or WRITE with auto precharge | $(BL / 2)$ | t_{CK} |
| | PRECHARGE or ACTIVE | 1 | t_{CK} |
| READ with auto precharge | READ or READ with auto precharge | $(BL / 2)$ | t_{CK} |
| | WRITE or WRITE with auto precharge | $(BL / 2) + 2$ | t_{CK} |
| | PRECHARGE or ACTIVE | 1 | t_{CK} |

4. REFRESH and LM commands may only be issued when all banks are idle.
5. Not used.
6. All states and sequences not shown are illegal or reserved.
7. READs or WRITEs listed in the Command/Action column include READs or WRITEs with auto precharge enabled and READs or WRITEs with auto precharge disabled.
8. Requires appropriate DM.
9. A WRITE command may be applied after the completion of the READ burst.
10. The number of clock cycles required to meet t_{WTR} is either 2 or t_{WTR}/t_{CK} , whichever is greater.

DESELECT, NOP, and LM Commands

DESELECT

The Deselect function (CS# HIGH) prevents new commands from being executed by the DDR2 SDRAM. The DDR2 SDRAM is effectively deselected. Operations already in progress are not affected. Deselect is also referred to as COMMAND INHIBIT.

NO OPERATION (NOP)

The NO OPERATION (NOP) command is used to instruct the selected DDR2 SDRAM to perform a NOP (CS# is LOW; RAS#, CAS#, and WE are HIGH). This prevents unwanted commands from being registered during idle or wait states. Operations already in progress are not affected.

LOAD MODE (LM)

The mode registers are loaded via inputs BA2–BA0 and A13–A0 for x4 and x8, and A12–A0 for x16 configurations. BA2–BA0 determine which mode register will be programmed. See “Mode Register (MR)” on page 24. The LM command can only be issued when all banks are idle, and a subsequent executable command cannot be issued until t_{MRD} is met.

Bank/Row Activation

ACTIVE Command

The ACTIVE command is used to open (or activate) a row in a particular bank for a subsequent access. The value on the BA2–BA0 inputs selects the bank, and the address provided on inputs (A13–A0 for x4 and x8, and A12–A0 for x16) selects the row. This row remains active (or open) for accesses until a PRECHARGE command is issued to that bank. A PRECHARGE command must be issued before opening a different row in the same bank.

ACTIVE Operation

Before any READ or WRITE commands can be issued to a bank within the DDR2 SDRAM, a row in that bank must be opened (activated), even when additive latency is used. This is accomplished via the ACTIVE command, which selects both the bank and the row to be activated, as shown in Figure 18 on page 40.

After a row is opened with an ACTIVE command, a READ or WRITE command may be issued to that row subject to the t_{RCD} specification. $t_{RCD}(\text{MIN})$ should be divided by the clock period and rounded up to the next whole number to determine the earliest clock edge after the ACTIVE command on which a READ or WRITE command can be entered. The same procedure is used to convert other specification limits from time units to clock cycles. For example, a $t_{RCD}(\text{MIN})$ specification of 20ns with a 266 MHz clock ($t_{CK} = 3.75\text{ns}$) results in 5.3 clocks, rounded up to 6. This is reflected in Figure 21 on page 42, which covers any case where $5 < t_{RCD}(\text{MIN}) / t_{CK} \leq 6$. Figure 21 also shows the case for t_{RRD} where $2 < t_{RRD}(\text{MIN}) / t_{CK} \leq 3$.

A subsequent ACTIVE command to a different row in the same bank can only be issued after the previous active row has been closed (precharged). The minimum time interval between successive ACTIVE commands to the same bank is defined by t_{RC} .

A subsequent ACTIVE command to another bank can be issued while the first bank is being accessed, which results in a reduction of total row-access overhead. The minimum time interval between successive ACTIVE commands to different banks is defined by t_{RRD} .

Figure 18: ACTIVE Command

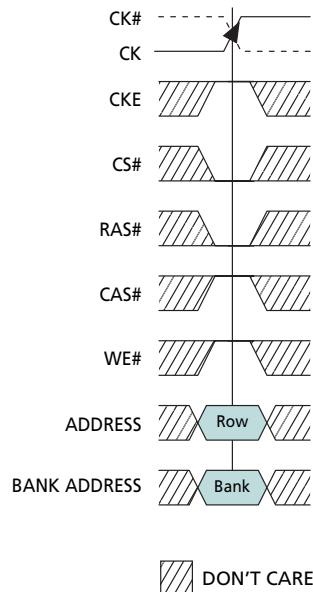

DDR2 SDRAM also supports the AL feature, which allows a READ or WRITE command to be issued prior to t_{RCD} (MIN) by delaying the actual registration of the READ/WRITE command to the internal device by AL clock cycles.

No more than 4-bank ACTIVE commands may be issued in a given t_{FAW} (MIN) period. t_{RRD} (MIN) restriction still applies. The t_{FAW} (MIN) parameters apply to all 8-bank DDR2 devices, regardless of the number of banks already open or closed, as shown in Figure 19.

Figure 19: 8-Bank Activate Restriction

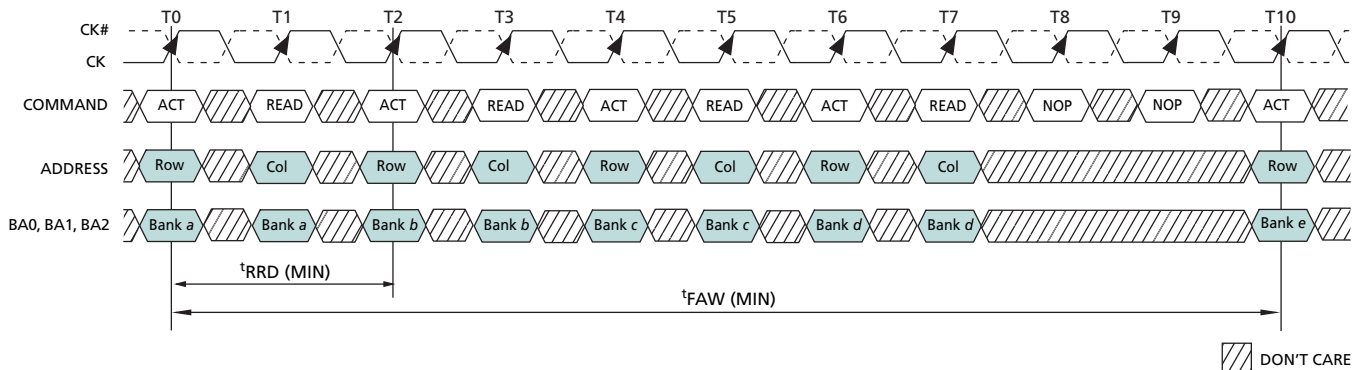

Note: 8-bank DDR2-533 (-37E, x4 or x8), $t_{CK} = 3.75ns$, BL = 4, AL = 3, CL = 4, t_{RRD} (MIN) = 7.5ns, t_{FAW} (MIN) = 37.5ns.

READ Command

The READ command is used to initiate a burst read access to an active row. The value on the BA2–BA0 inputs selects the bank, and the address provided on inputs A0–*i* (where *i* = A9 for x16, A9 for x8, or A9, A11 for x4) selects the starting column location. The value on input A10 determines whether or not auto precharge is used. If auto precharge is selected, the row being accessed will be precharged at the end of the READ burst; if auto precharge is not selected, the row will remain open for subsequent accesses.

READ Operation

READ bursts are initiated with a READ command, as shown in Figure 20 on page 42. The starting column and bank addresses are provided with the READ command and auto precharge is either enabled or disabled for that burst access. If auto precharge is enabled, the row being accessed is automatically precharged at the completion of the burst. If auto precharge is disabled, the row will be left open after the completion of the burst.

During READ bursts, the valid data-out element from the starting column address will be available READ latency (RL) clocks later. RL is defined as the sum of AL and CL; $RL = AL + CL$. The value for AL and CL are programmable via the MR and EMR commands, respectively. Each subsequent data-out element will be valid nominally at the next positive or negative clock edge (i.e., at the next crossing of CK and CK#). Figure 22 on page 43 shows examples of RL based on different AL and CL settings.

DQS/DQS# is driven by the DDR2 SDRAM along with output data. The initial LOW state on DQS and HIGH state on DQS# is known as the read preamble (t_{RPRE}). The LOW state on DQS and HIGH state on DQS# coincident with the last data-out element is known as the read postamble (t_{RPST}).

Upon completion of a burst, assuming no other commands have been initiated, the DQ will go High-Z. A detailed explanation of t_{DQSQ} (valid data-out skew), t_{QH} (data-out window hold), and the valid data window are depicted in Figure 31 on page 51 and Figure 32 on page 52. A detailed explanation of t_{DQSCK} (DQS transition skew to CK) and t_{AC} (data-out transition skew to CK) is shown in Figure 33 on page 53.

Data from any READ burst may be concatenated with data from a subsequent READ command to provide a continuous flow of data. The first data element from the new burst follows the last element of a completed burst. The new READ command should be issued *x* cycles after the first READ command, where *x* equals $BL / 2$ cycles. This is shown in Figure 23 on page 44.

Figure 20: READ Command

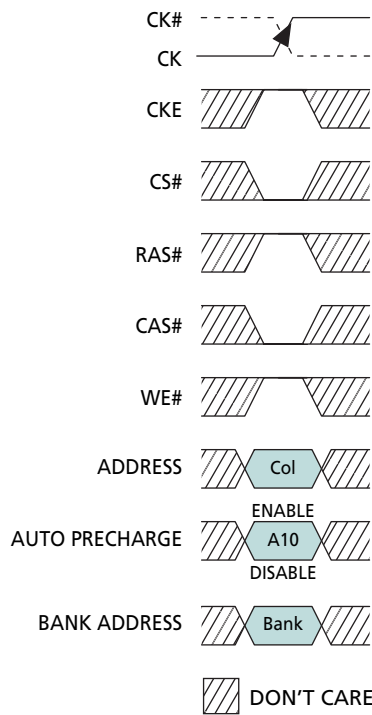

Figure 21: Example: Meeting $t_{RRD}^{(MIN)}$ and $t_{RCD}^{(MIN)}$

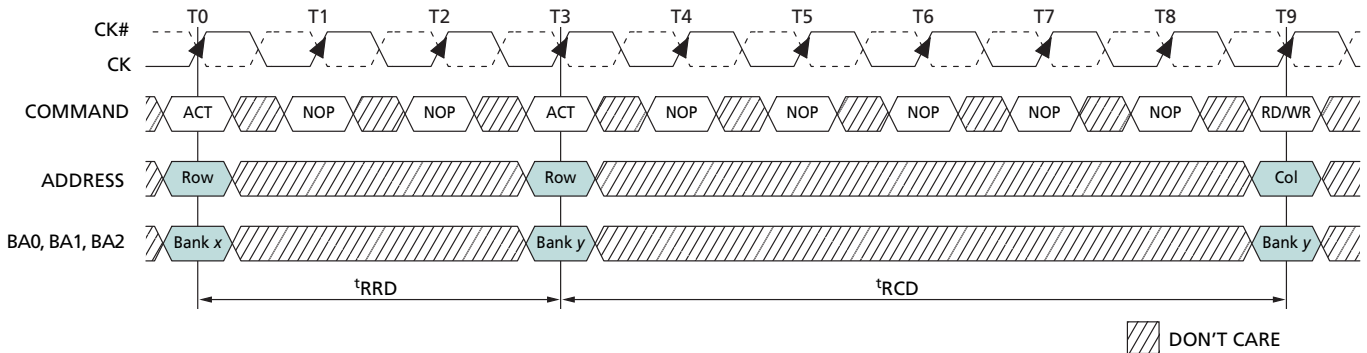
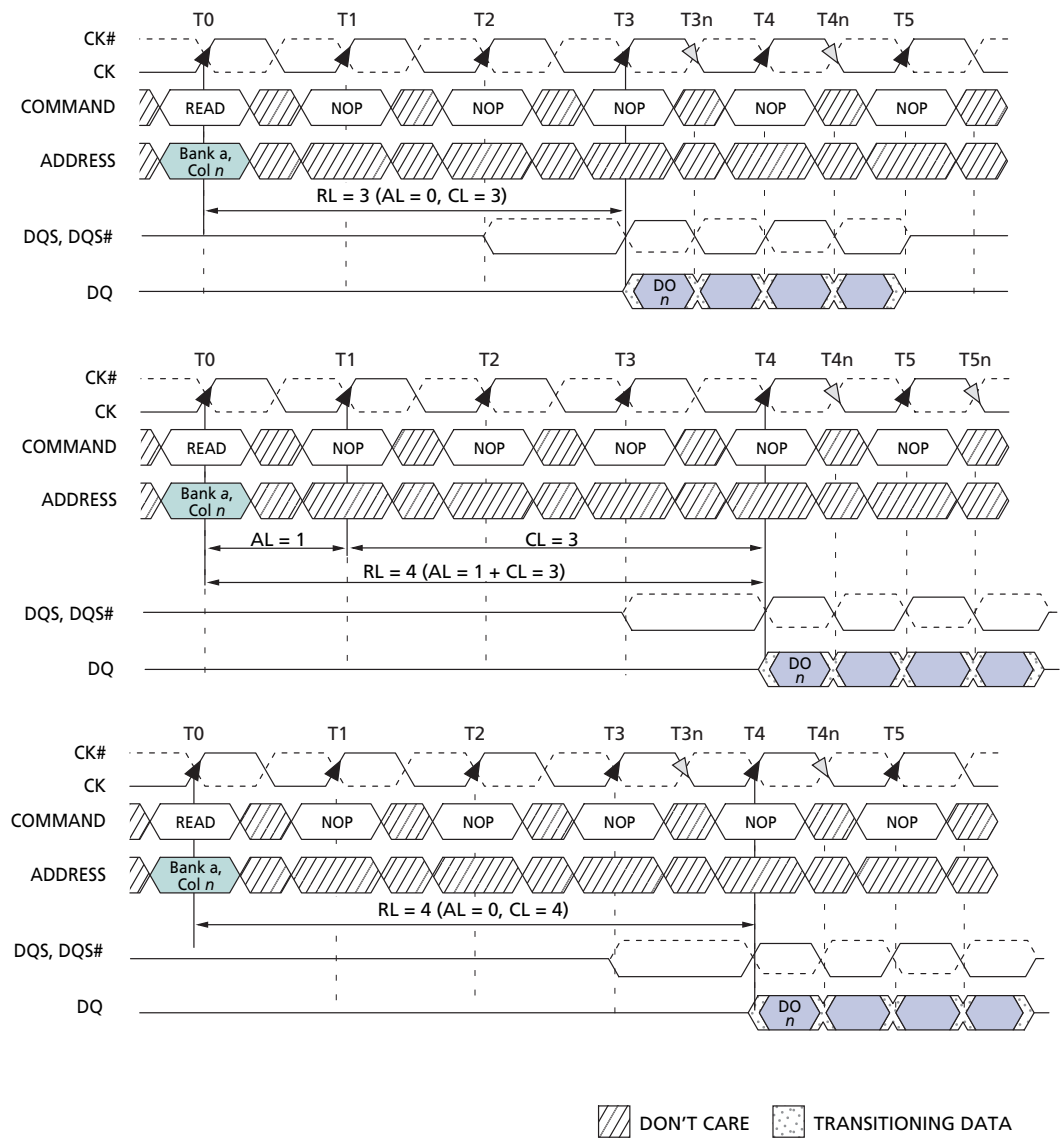
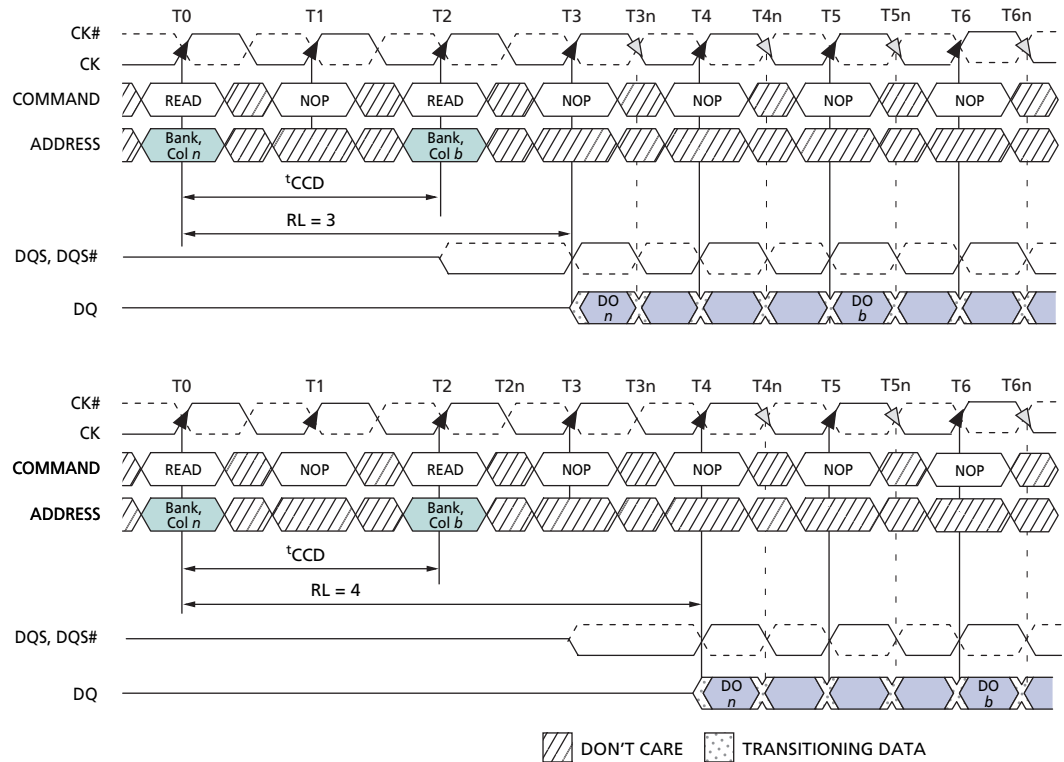

Figure 22: READ Latency



- Notes:
1. DO n = data-out from column n .
 2. BL = 4.
 3. Three subsequent elements of data-out appear in the programmed order following DO n .
 4. Shown with nominal t_{AC} , t_{DQSK} , and t_{DQSQ} .

Figure 23: Consecutive READ Bursts



- Notes:
1. DO *n* (or *b*) = data-out from column *n* (or column *b*).
 2. BL = 4.
 3. Three subsequent elements of data-out appear in the programmed order following DO *n*.
 4. Three subsequent elements of data-out appear in the programmed order following DO *b*.
 5. Shown with nominal t_{AC} , t_{DQSK} , and t_{DQSQ} .
 6. Example applies only when READ commands are issued to same device.

Nonconsecutive read data is illustrated in Figure 24 on page 45. Full-speed random read accesses within a page (or pages) can be performed. DDR2 SDRAM supports the use of concurrent auto precharge timing, shown in Table 10 on page 46.

DDR2 SDRAM does not allow interrupting or truncating of any READ burst using BL = 4 operations. Once the BL = 4 READ command is registered, it must be allowed to complete the entire READ burst. However, a READ (with auto precharge disabled) using BL = 8 operation may be interrupted and truncated *only* by another READ burst as long as the interruption occurs on a 4-bit boundary due to the 4*n* prefetch architecture of DDR2 SDRAM. READ burst BL = 8 operations may not be interrupted or truncated with any command except another READ command, as shown in Figure 25 on page 45.

Figure 24: Nonconsecutive READ Bursts

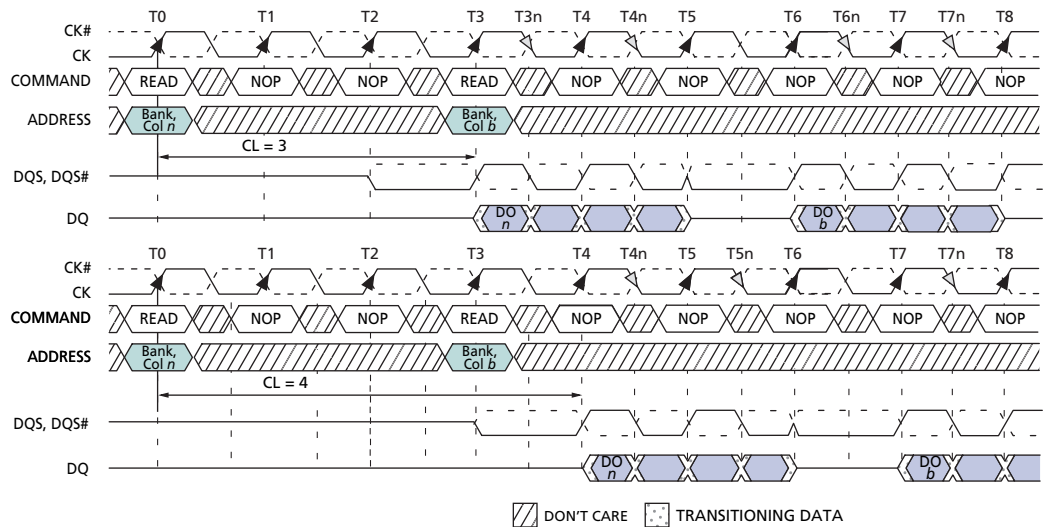

- Notes:
1. DO *n* (or *b*) = data-out from column *n* (or column *b*).
 2. BL = 4.
 3. Three subsequent elements of data-out appear in the programmed order following DO *n*.
 4. Three subsequent elements of data-out appear in the programmed order following DO *b*.
 5. Shown with nominal t_{AC} , t_{DQSK} , and t_{DQSQ} .
 6. Example applies when READ commands are issued to different devices or nonconsecutive READs.

Figure 25: READ Interrupted by READ

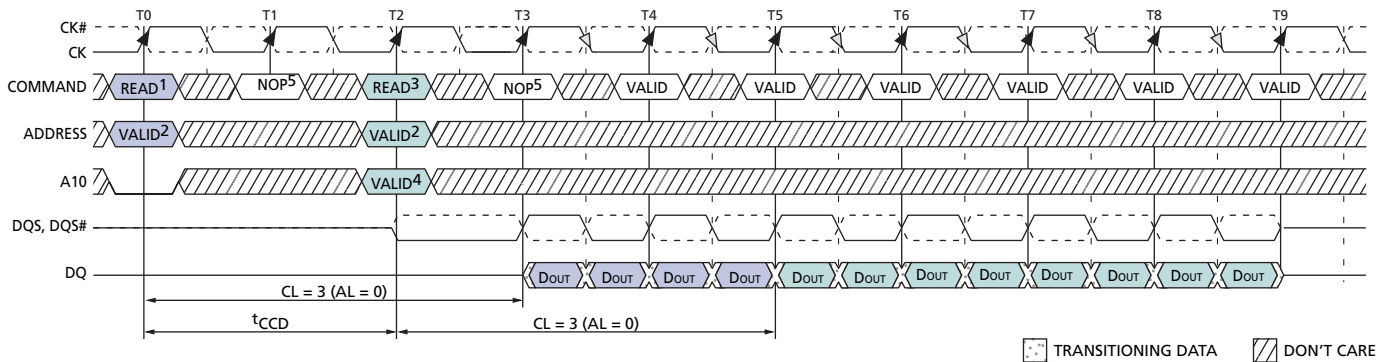

- Notes:
1. BL = 8 required; auto precharge must be disabled (A10 = LOW).
 2. READ command can be issued to any valid bank and row address (READ command at T0 and T2 can be either same bank or different bank).
 3. Interrupting READ command must be issued exactly $2 \times t_{CK}$ from previous READ.
 4. Auto precharge can be either enabled (A10 = HIGH) or disabled (A10 = LOW) by the interrupting READ command.
 5. NOP or COMMAND INHIBIT commands are valid. PRECHARGE command cannot be issued to banks used for READs at T0 and T2.
 6. Example shown uses AL = 0; CL = 3, BL = 8, shown with nominal t_{AC} , t_{DQSK} , and t_{DQSQ} .

Table 10: READ Using Concurrent Auto Precharge

| From Command (Bank <i>n</i>) | To Command (Bank <i>m</i>) | Minimum Delay (with Concurrent Auto Precharge) | Units |
|-------------------------------|------------------------------------|--|-----------------|
| READ with auto precharge | READ or READ with auto precharge | BL/2 | ^t CK |
| | WRITE or WRITE with auto precharge | (BL/2) + 2 | ^t CK |
| | PRECHARGE or ACTIVE | 1 | ^t CK |

Data from any READ burst must be completed before a subsequent WRITE burst is allowed. An example of a READ burst followed by a WRITE burst is shown in Figure 28 on page 48. The ^tDQSS (MIN) case is shown; the ^tDQSS (MAX) case has a longer bus idle time. (^tDQSS [MIN] and ^tDQSS [MAX] are defined in Figure 35 on page 56.)

A READ burst may be followed by a PRECHARGE command to the same bank, provided that auto precharge was not activated. The minimum READ-to-PRECHARGE command spacing to the same bank is AL + BL/2 clocks and must also satisfy a minimum analog time from the rising clock edge that initiates the last 4-bit prefetch of a READ-to-PRECHARGE command. This READ-to-PRECHARGE time is called ^tRTP. For BL = 4 this is the time from the actual READ (AL after the READ command) to PRECHARGE command. For BL = 8 this is the time from AL + 2CK after the READ-to-PRECHARGE command. Following the PRECHARGE command, a subsequent command to the same bank cannot be issued until ^tRP is met.

Note: Part of the row precharge time is hidden during the access of the last data elements.

Examples of READ-to-PRECHARGE are shown in Figure 26 on page 47 for BL = 4 and Figure 27 on page 47 for BL = 8. The delay from READ-to-PRECHARGE command to the same bank is AL + BL/2 + MAX (^tRTP/^tCK or 2CK) - 2CK.

If A10 is HIGH when a READ command is issued, the READ with auto precharge function is engaged. The DDR2 SDRAM starts an auto precharge operation on the rising edge, which is AL + (BL/2) cycles later than the READ with auto precharge command if ^tRAS (MIN) and ^tRTP are satisfied. If ^tRAS (MIN) is not satisfied at the edge, the start point of auto precharge operation will be delayed until ^tRAS (MIN) is satisfied. If ^tRTP (MIN) is not satisfied at the edge, the start point of the auto precharge operation will be delayed until ^tRTP (MIN) is satisfied. In case the internal precharge is pushed out by ^tRTP, ^tRP starts at the point where the internal precharge happens (not at the next rising clock edge after this event). For BL = 4, the minimum time from READ with auto precharge to the next ACTIVATE command becomes AL + (^tRTP + ^tRP)*, shown in Figure 26 on page 47; for BL = 8, the time from READ with auto precharge to the next ACTIVATE command is AL + 2 clocks + (^tRTP + ^tRP)*, shown in Figure 27 on page 47. The * indicates each parameter term is divided by ^tCK and rounded up to the next integer. In any event, internal precharge does not start earlier than two clocks after the last 4-bit prefetch.

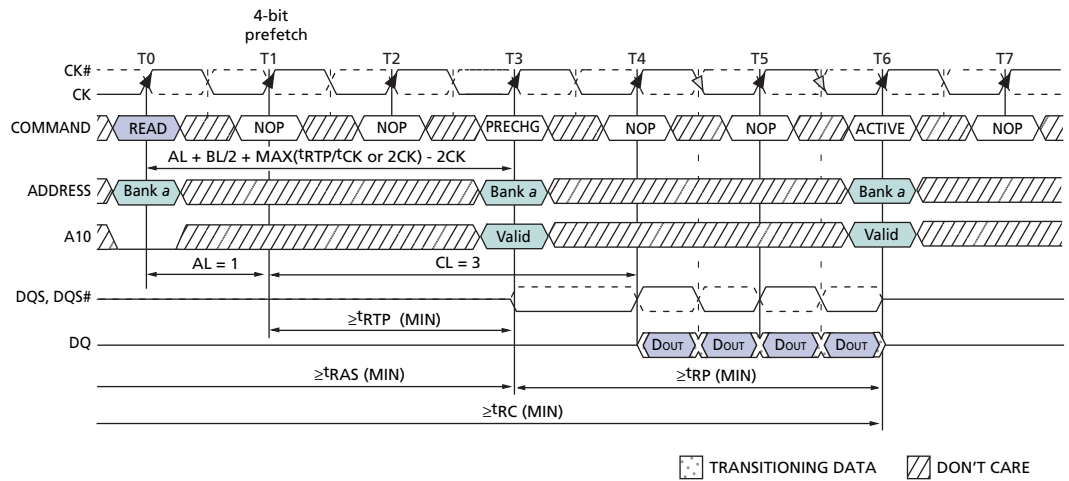
Figure 26: READ-to-PRECHARGE – BL = 4

- Notes:
1. RL = 4 (AL = 1, CL = 3); BL = 4.
 2. $t_{RTP} \geq 2$ clocks.
 3. Shown with nominal t_{AC} , t_{DQSC} , and t_{DQSQ} .

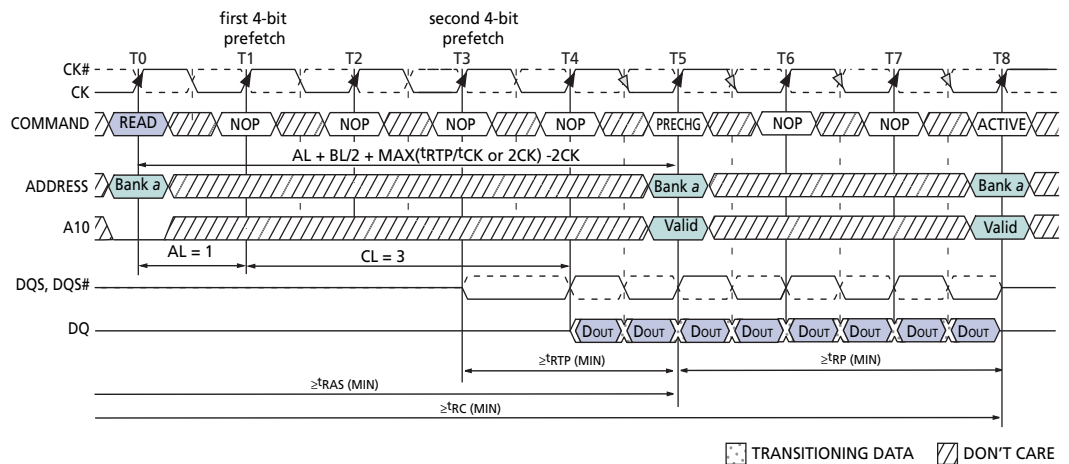
Figure 27: READ-to-PRECHARGE – BL = 8

- Notes:
1. RL = 4 (AL = 1, CL = 3); BL = 8.
 2. $t_{RTP} \geq 2$ clocks.
 3. Shown with nominal t_{AC} , t_{DQSC} , and t_{DQSQ} .

Figure 28: READ-to-WRITE

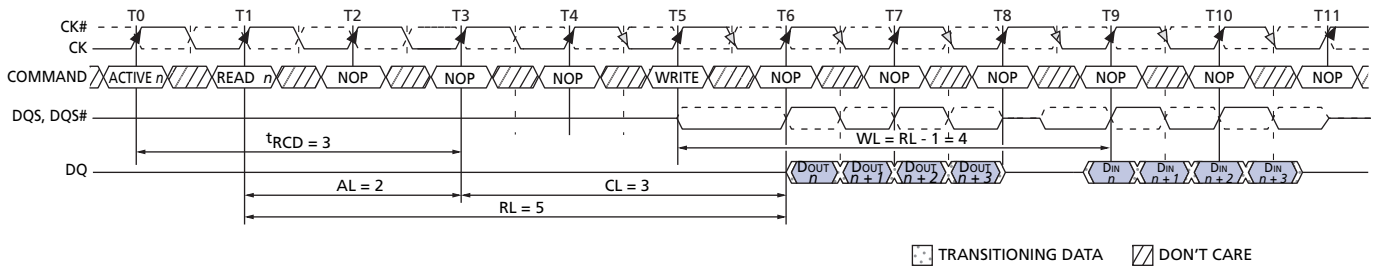

- Notes:
1. BL = 4; CL = 3; AL = 2.
 2. Shown with nominal t_{AC} , t_{DQSCK} , and t_{DQSQ} .

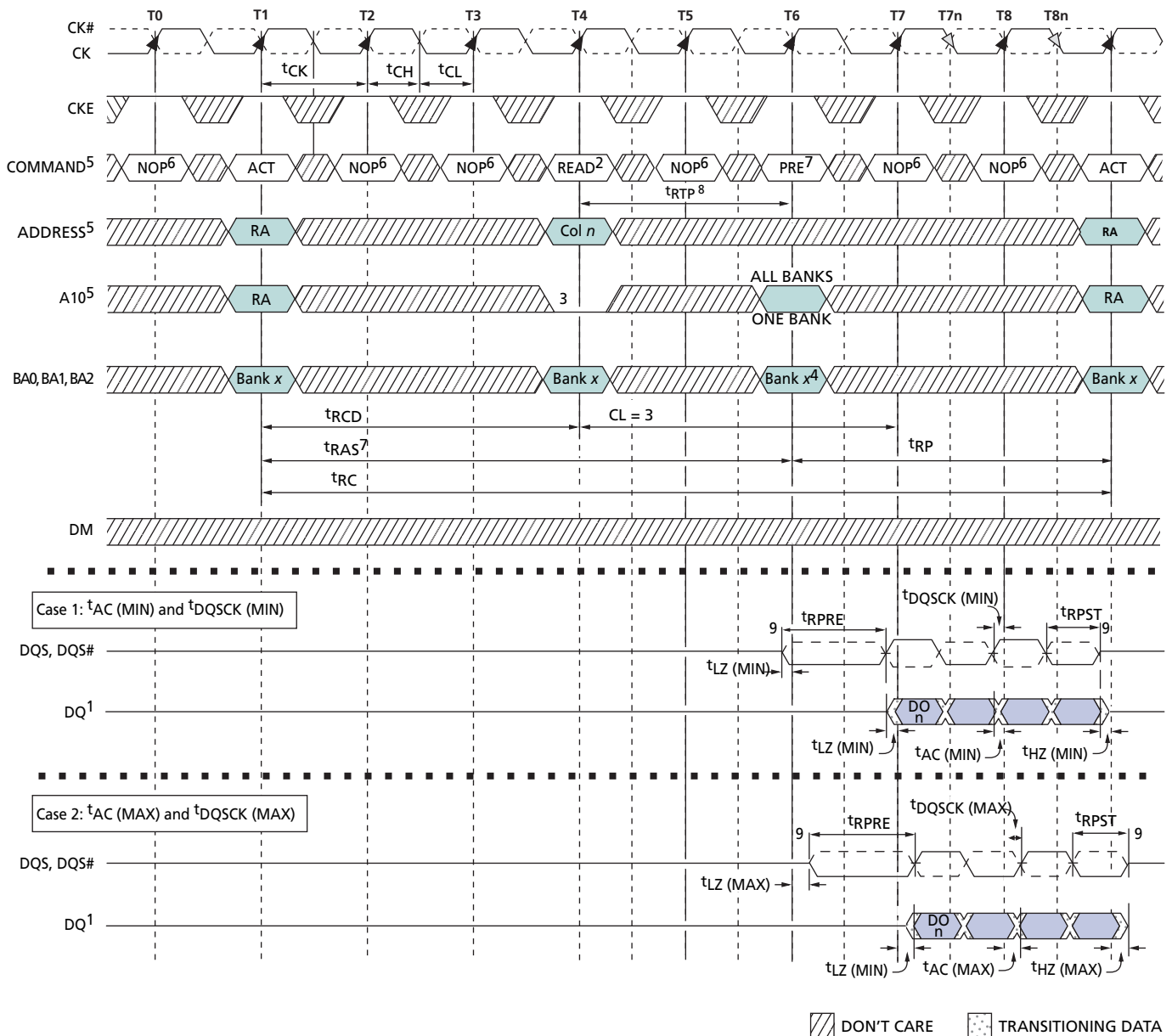
Figure 29: Bank Read – without Auto Precharge

- Notes:
1. DO n = data-out from column n ; subsequent elements are applied in the programmed order.
 2. BL = 4 and AL = 0 in the case shown.
 3. Disable auto precharge.
 4. "Don't Care" if A10 is HIGH at T5.
 5. PRE = PRECHARGE, ACT = ACTIVE, RA = row address, BA = bank address.
 6. NOP commands are shown for ease of illustration; other commands may be valid at these times.
 7. The PRECHARGE command can only be applied at T6 if t_{RAS} (MIN) is met.
 8. READ-to-PRECHARGE = AL + BL/2 + (t_{RTP} - 2 clocks).
 9. I/O balls, when entering or exiting HIGH-Z, are not referenced to a specific voltage level, but to when the device begins to drive or no longer drives, respectively.

Figure 30: Bank Read – with Auto Precharge

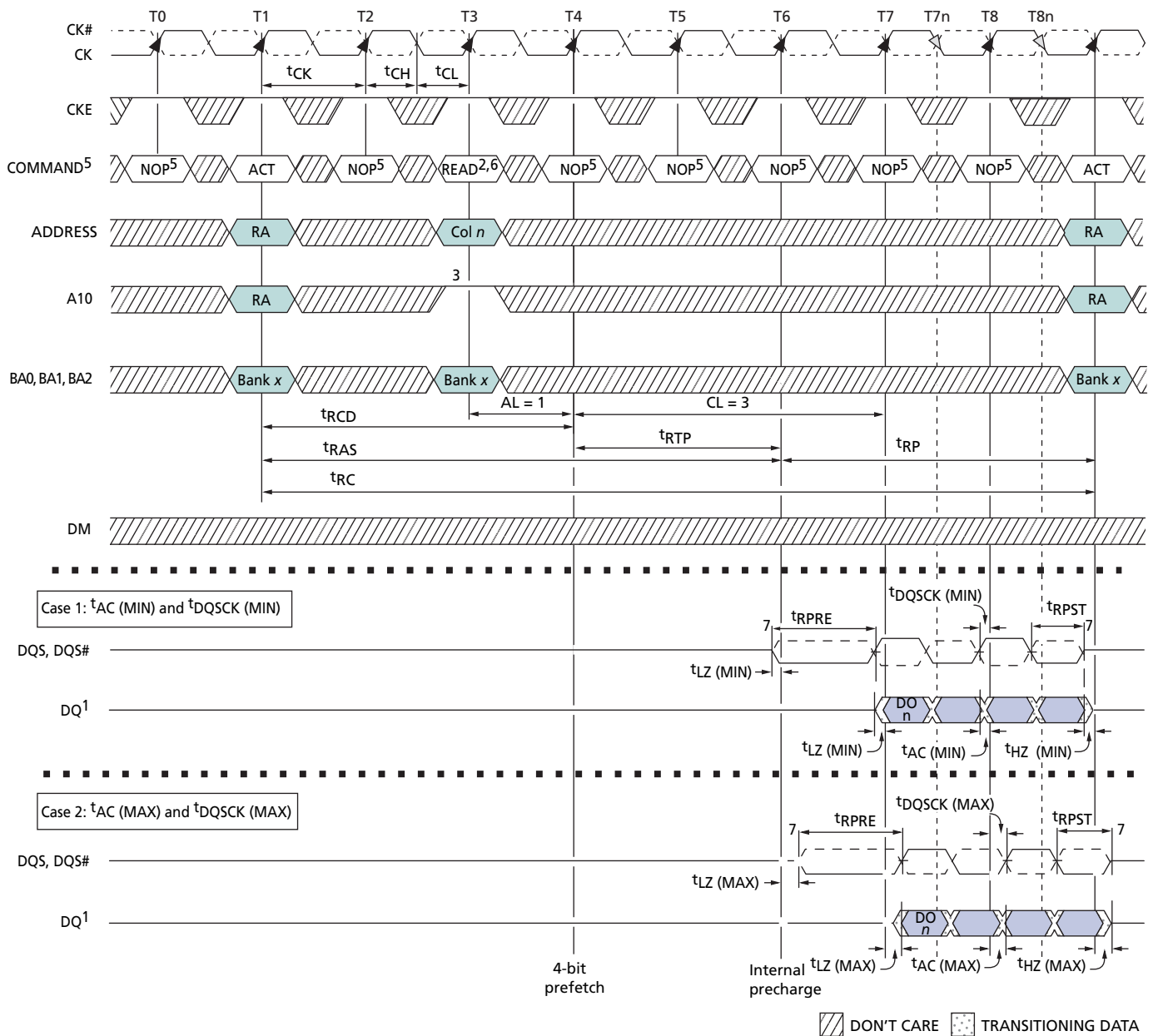

- Notes:
1. DO n = data-out from column n ; subsequent elements are applied in the programmed order.
 2. BL = 4, RL = 4 (AL = 1, CL = 3) in the case shown.
 3. Enable auto precharge.
 4. ACT = ACTIVE, RA = row address, BA = bank address.
 5. NOP commands are shown for ease of illustration; other commands may be valid at these times.
 6. The DDR2 SDRAM internally delays auto precharge until both t_{RAS} (MIN) and t_{RTP} (MIN) have been satisfied.
 7. I/O balls, when entering or exiting HIGH-Z, are not referenced to a specific voltage level, but to when the device begins to drive or no longer drives, respectively.

Figure 31: x4, x8 Data Output Timing – t_{DQSQ} , t_{QH} , and Data Valid Window

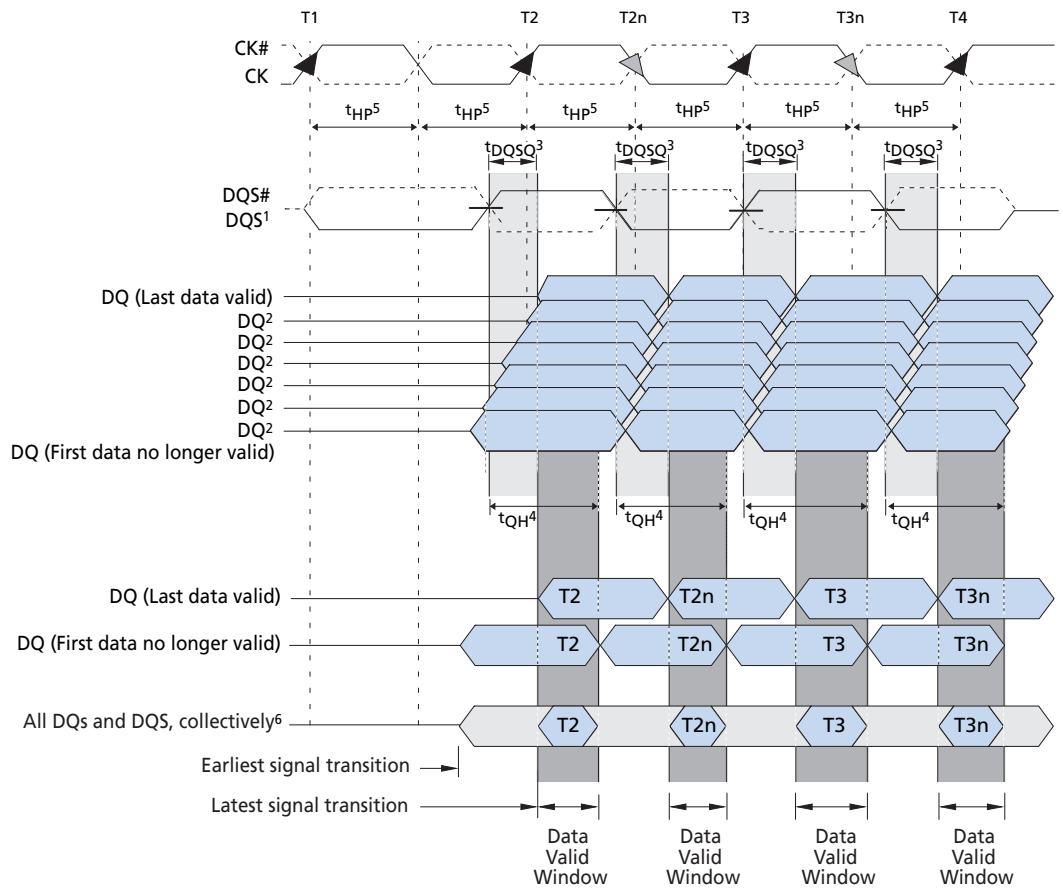

- Notes:
1. DQ transitioning after DQS transition define t_{DQSQ} window. DQS transitions at T2 and at T2n are "early DQS," at T3 are "nominal DQS," and at T3n are "late DQS."
 2. DQ0, DQ1, DQ2, DQ3 for x4 or DQ0–DQ7 for x8.
 3. t_{DQSQ} is derived at each DQS clock edge, is not cumulative over time, begins with DQS transitions, and ends with the last valid transition of DQ.
 4. t_{QH} is derived from t_{HP} : $t_{QH} = t_{HP} - t_{QHS}$.
 5. t_{HP} is the lesser of t_{CL} or t_{CH} clock transitions collectively when a bank is active.
 6. The data valid window is derived for each DQS transition and is defined as $t_{QH} - t_{DQSQ}$.

Figure 32: x16 Data Output Timing – t_{DQSQ} , t_{QH} , and Data Valid Window

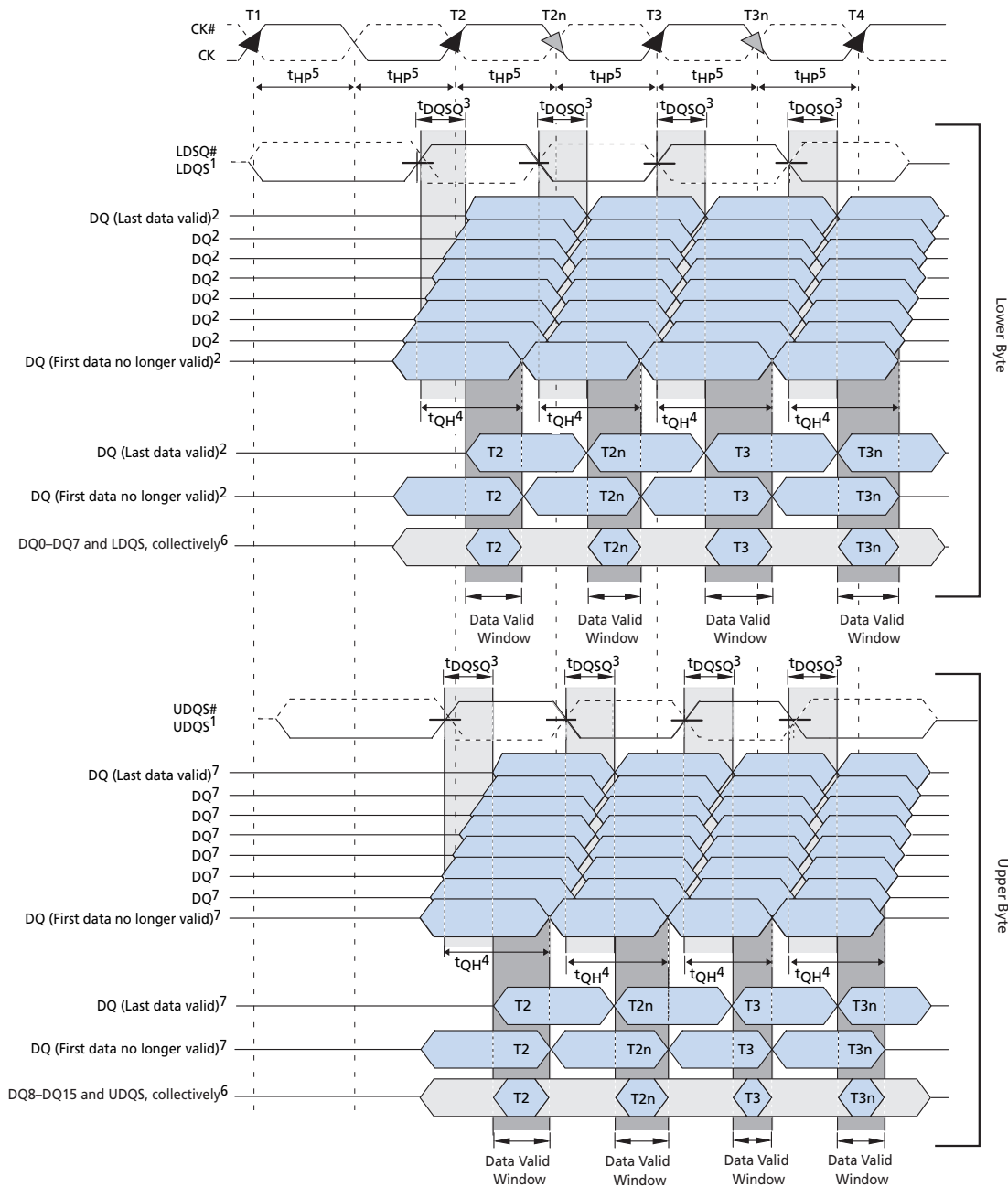

- Notes:
1. DQ transitioning after DQS transitions define the t_{DQSQ} window. LDQS defines the lower byte, and UDQS defines the upper byte.
 2. DQ0, DQ1, DQ2, DQ3, DQ4, DQ5, DQ6, or DQ7.
 3. t_{DQSQ} is derived at each DQS clock edge, is not cumulative over time, begins with DQS transitions, and ends with the last valid transition of DQ.
 4. t_{QH} is derived from t_{HP} : $t_{QH} = t_{HP} - t_{QHS}$.
 5. t_{HP} is the lesser of t_{CL} or t_{CH} clock transitions collectively when a bank is active.
 6. The data valid window is derived for each DQS transition and is $t_{QH} - t_{DQSQ}$.
 7. DQ8, DQ9, DQ10, DQ11, DQ12, DQ13, DQ14, or DQ15.

Figure 33: Data Output Timing – t_{AC} and t_{DQSCK}

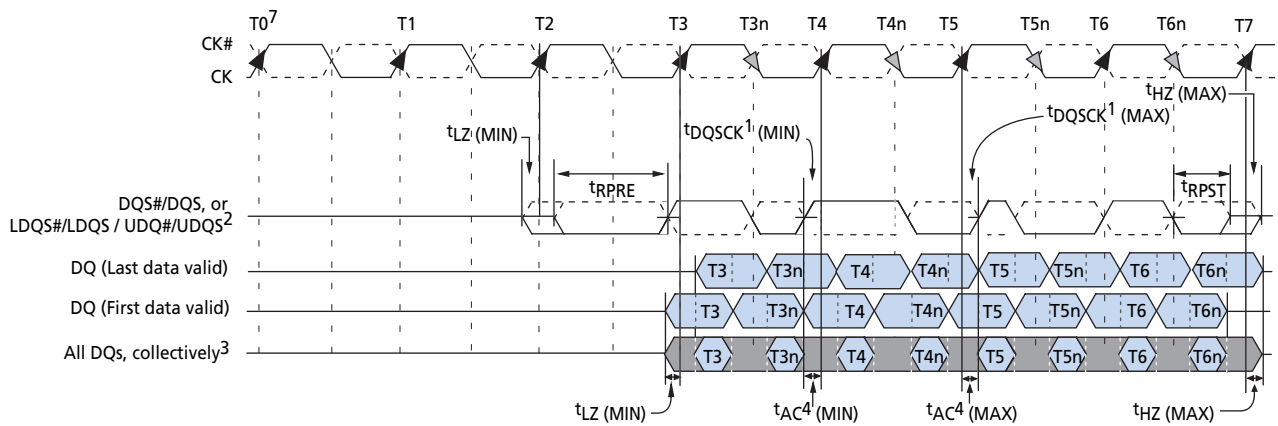

- Notes:
1. t_{DQSK} is the DQS output window relative to CK and is the “long-term” component of DQS skew.
 2. DQ transitioning after DQS transitions define t_{DQSQ} window.
 3. All DQ must transition by t_{DQSQ} after DQS transitions, regardless of t_{AC} .
 4. t_{AC} is the DQ output window relative to CK and is the “long term” component of DQ skew.
 5. $t_{LZ}(\text{MIN})$ and $t_{AC}(\text{MIN})$ are the first valid signal transitions.
 6. $t_{HZ}(\text{MAX})$ and $t_{AC}(\text{MAX})$ are the latest valid signal transitions.
 7. READ command with CL = 3, AL = 0 issued at T0.
 8. I/O balls, when entering or exiting HIGH-Z, are not referenced to a specific voltage level, but to when the device begins to drive or no longer drives, respectively.

WRITE Command

The WRITE command is used to initiate a burst write access to an active row. The value on the BA2–BA0 inputs selects the bank, and the address provided on inputs A0–*i* (where *i* = A9 for x8 and x16; or A9, A11 for x4) selects the starting column location. The value on input A10 determines whether or not auto precharge is used. If auto precharge is selected, the row being accessed will be precharged at the end of the WRITE burst; if auto precharge is not selected, the row will remain open for subsequent accesses.

Figure 34: WRITE Command

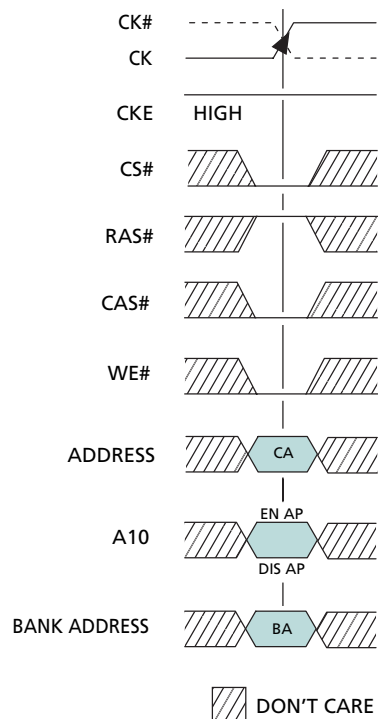

Note: CA = column address; BA = bank address; EN AP = enable auto precharge; and DIS AP = disable auto precharge.

Input data appearing on the DQ is written to the memory array subject to the DM input logic level appearing coincident with the data. If a given DM signal is registered LOW, the corresponding data will be written to memory; if the DM signal is registered HIGH, the corresponding data inputs will be ignored, and a WRITE will not be executed to that byte/column location (Figure 44 on page 63).

WRITE Operation

WRITE bursts are initiated with a WRITE command, as shown in Figure 34. DDR2 SDRAM uses WL equal to RL minus one clock cycle [WL = RL - 1CK = AL + (CL - 1CK)]. The starting column and bank addresses are provided with the WRITE command, and auto precharge is either enabled or disabled for that access. If auto precharge is enabled, the row being accessed is precharged at the completion of the burst.

Note: For the generic WRITE commands used in the following illustrations, auto precharge is disabled.

During WRITE bursts, the first valid data-in element will be registered on the first rising edge of DQS following the WRITE command, and subsequent data elements will be registered on successive edges of DQS. The LOW state on DQS between the WRITE command and the first rising edge is known as the write preamble; the LOW state on DQS following the last data-in element is known as the write postamble.

The time between the WRITE command and the first rising DQS edge is $WL \pm {}^tDQSS$. Subsequent DQS positive rising edges are timed, relative to the associated clock edge, as $\pm {}^tDQSS$. tDQSS is specified with a relatively wide range (25 percent of one clock cycle). All of the WRITE diagrams show the nominal case, and where the two extreme cases (tDQSS [MIN] and tDQSS [MAX]) might not be intuitive, they have also been included. Figure 35 on page 56 shows the nominal case and the extremes of tDQSS for BL = 4. Upon completion of a burst, assuming no other commands have been initiated, the DQ will remain High-Z and any additional input data will be ignored.

Data for any WRITE burst may be concatenated with a subsequent WRITE command to provide continuous flow of input data. The first data element from the new burst is applied after the last element of a completed burst. The new WRITE command should be issued x cycles after the first WRITE command, where x equals BL/2.

Figure 36 on page 57 shows concatenated bursts of BL = 4. An example of nonconsecutive WRITES is shown in Figure 37 on page 57. Full-speed random write accesses within a page or pages can be performed as shown in Figure 38 on page 58. DDR2 SDRAM supports concurrent auto precharge options, as shown in Table 11.

DDR2 SDRAM does not allow interrupting or truncating any WRITE burst using BL = 4 operation. Once the BL = 4 WRITE command is registered, it must be allowed to complete the entire WRITE burst cycle. However, a WRITE BL = 8 operation (with auto precharge disabled) might be interrupted and truncated ONLY by another WRITE burst as long as the interruption occurs on a 4-bit boundary, due to the $4n$ prefetch architecture of DDR2 SDRAM. WRITE burst BL = 8 operations may *not* be interrupted or truncated with any command except another WRITE command, as shown in Figure 39 on page 58.

Data for any WRITE burst may be followed by a subsequent READ command. To follow a WRITE, tWTR should be met, as shown in Figure 40 on page 59. The number of clock cycles required to meet tWTR is either 2 or ${}^tWTR/{}^tCK$, whichever is greater. Data for any WRITE burst may be followed by a subsequent PRECHARGE command. tWR must be met, as shown in Figure 41 on page 60. tWR starts at the end of the data burst, regardless of the data mask condition.

Table 11: WRITE Using Concurrent Auto Precharge

| From Command (Bank n) | To Command (Bank m) | Minimum Delay (with concurrent auto precharge) | Units |
|---------------------------|------------------------------------|--|----------|
| WRITE with auto precharge | READ or READ with auto precharge | $(CL - 1) + (BL/2) + {}^tWTR$ | tCK |
| | WRITE or WRITE with auto precharge | $(BL/2)$ | tCK |
| | PRECHARGE or ACTIVE | 1 | tCK |

Figure 35: WRITE Burst

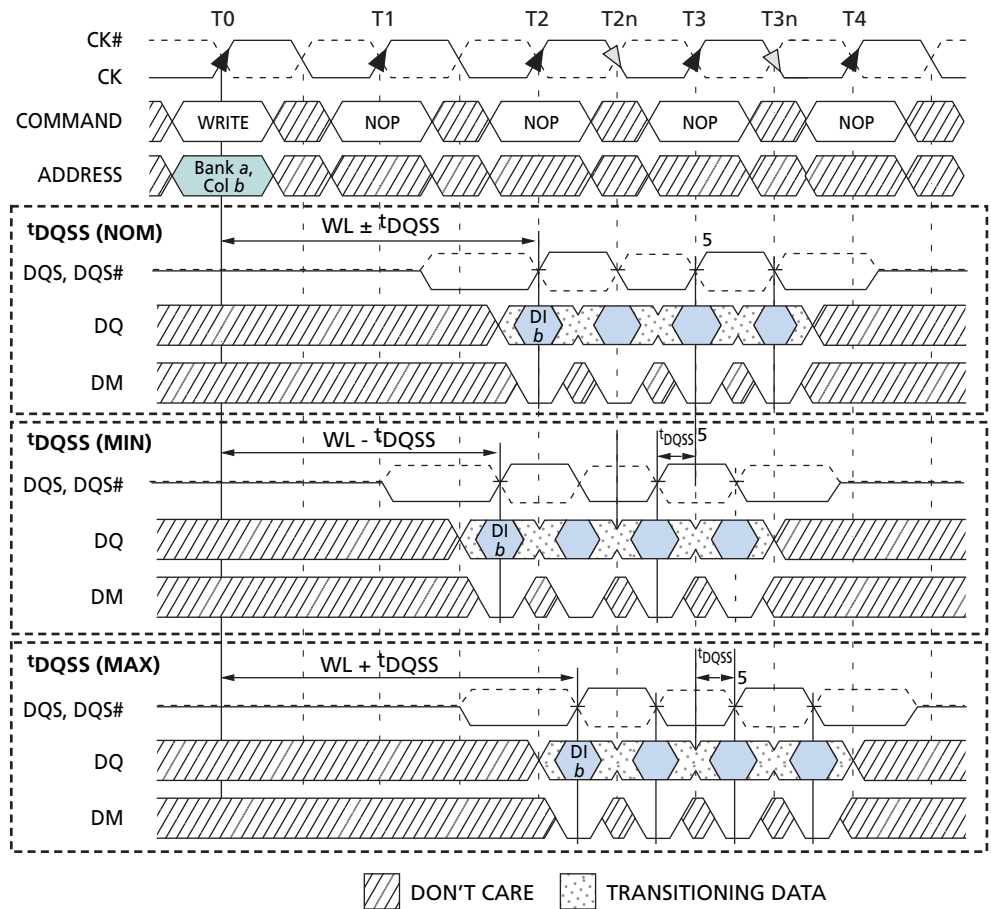

- Notes:
1. DI *b* = data-in for column *b*.
 2. Three subsequent elements of data-in are applied in the programmed order following DI *b*.
 3. Shown with BL = 4, AL = 0, CL = 3; thus, WL = 2.
 4. A10 is LOW with the WRITE command (auto precharge is disabled).
 5. Subsequent rising DQS signals must align to the clock within t_{DQSS} .

Figure 36: Consecutive WRITE-to-WRITE

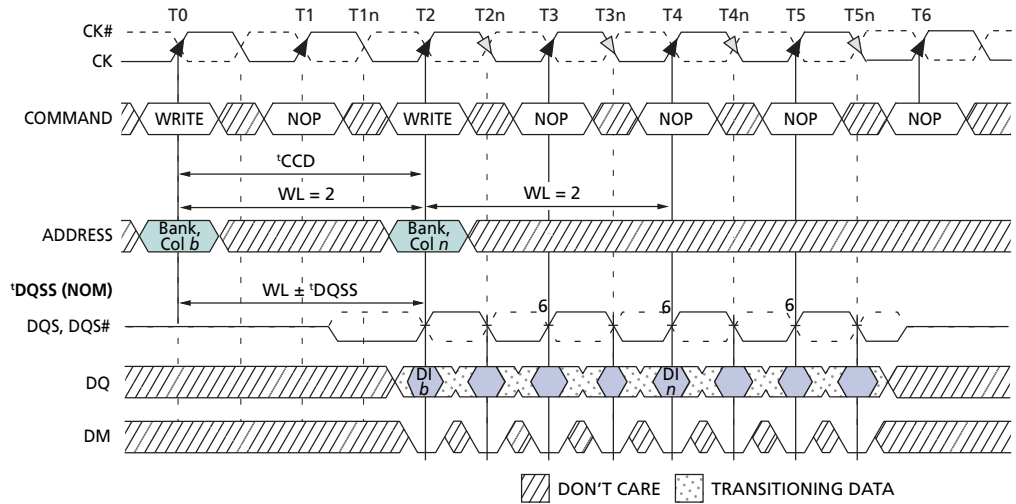

- Notes:
1. DI *b*, etc. = data-in for column *b*, etc.
 2. Three subsequent elements of data-in are applied in the programmed order following DI *b*.
 3. Three subsequent elements of data-in are applied in the programmed order following DI *n*.
 4. Shown with BL = 4, AL = 0, CL = 3; thus, WL = 2.
 5. Each WRITE command may be to any bank.
 6. Subsequent rising DQS signals must align to the clock within t^{DQSS} .

Figure 37: Nonconsecutive WRITE-to-WRITE

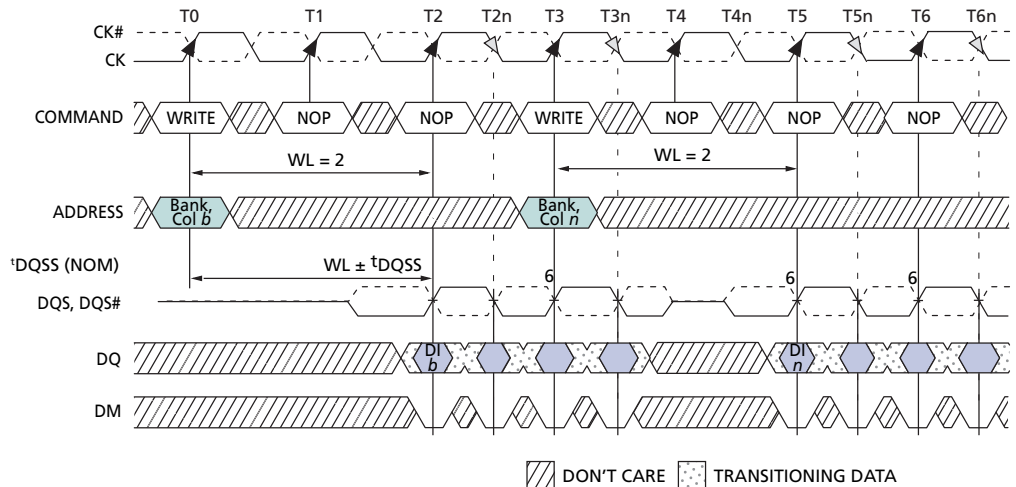

- Notes:
1. DI *b*, etc. = data-in for column *b*, etc.
 2. Three subsequent elements of data-in are applied in the programmed order following DI *b*.
 3. Three subsequent elements of data-in are applied in the programmed order following DI *n*.
 4. Shown with BL = 4, AL = 0, CL = 3; thus, WL = 2.
 5. Each WRITE command may be to any bank.
 6. Subsequent rising DQS signals must align to the clock within t^{DQSS} .

Figure 38: Random WRITE Cycles

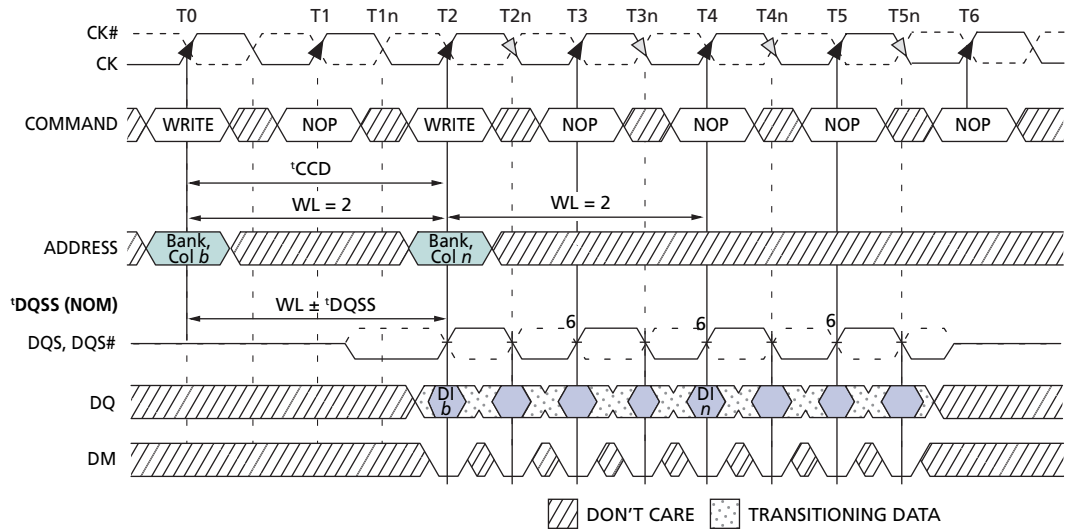

- Notes:
1. DI *b*, etc. = data-in for column *b*, etc.
 2. Three subsequent elements of data-in are applied in the programmed order following DI *b*.
 3. Three subsequent elements of data-in are applied in the programmed order following DI *n*.
 4. Shown with BL = 4, AL = 0, CL = 3; thus, WL = 2.
 5. Each WRITE command may be to any bank.
 6. Subsequent rising DQS signals must align to the clock within t^{DQSS} .

Figure 39: WRITE Interrupted by WRITE

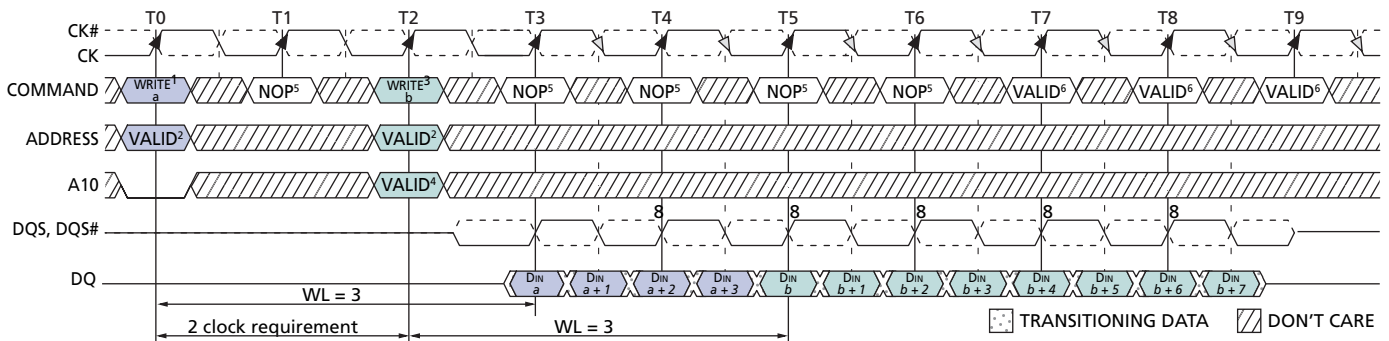

- Notes:
1. BL = 8 required and auto precharge must be disabled (A10 = LOW).
 2. WRITE command can be issued to any valid bank and row address (WRITE command at T0 and T2 can be either same bank or different bank).
 3. Interrupting WRITE command must be issued exactly $2 \times t^{\text{CK}}$ from previous WRITE.
 4. Auto precharge can be either enabled (A10 = HIGH) or disabled (A10 = LOW) by the interrupting WRITE command.
 5. NOP or COMMAND INHIBIT commands are valid. PRECHARGE command cannot be issued to banks used for WRITES at T0 and T2.
 6. Earliest WRITE-to-PRECHARGE timing for WRITE at T0 is $WL + BL/2 + t^{\text{WR}}$ where t^{WR} starts with T7 and not T5 (since BL = 8 from MR and not the truncated length).
 7. Example shown uses AL = 0; CL = 4, BL = 8.
 8. Subsequent rising DQS signals must align to the clock within t^{DQSS} .

Figure 40: WRITE-to-READ

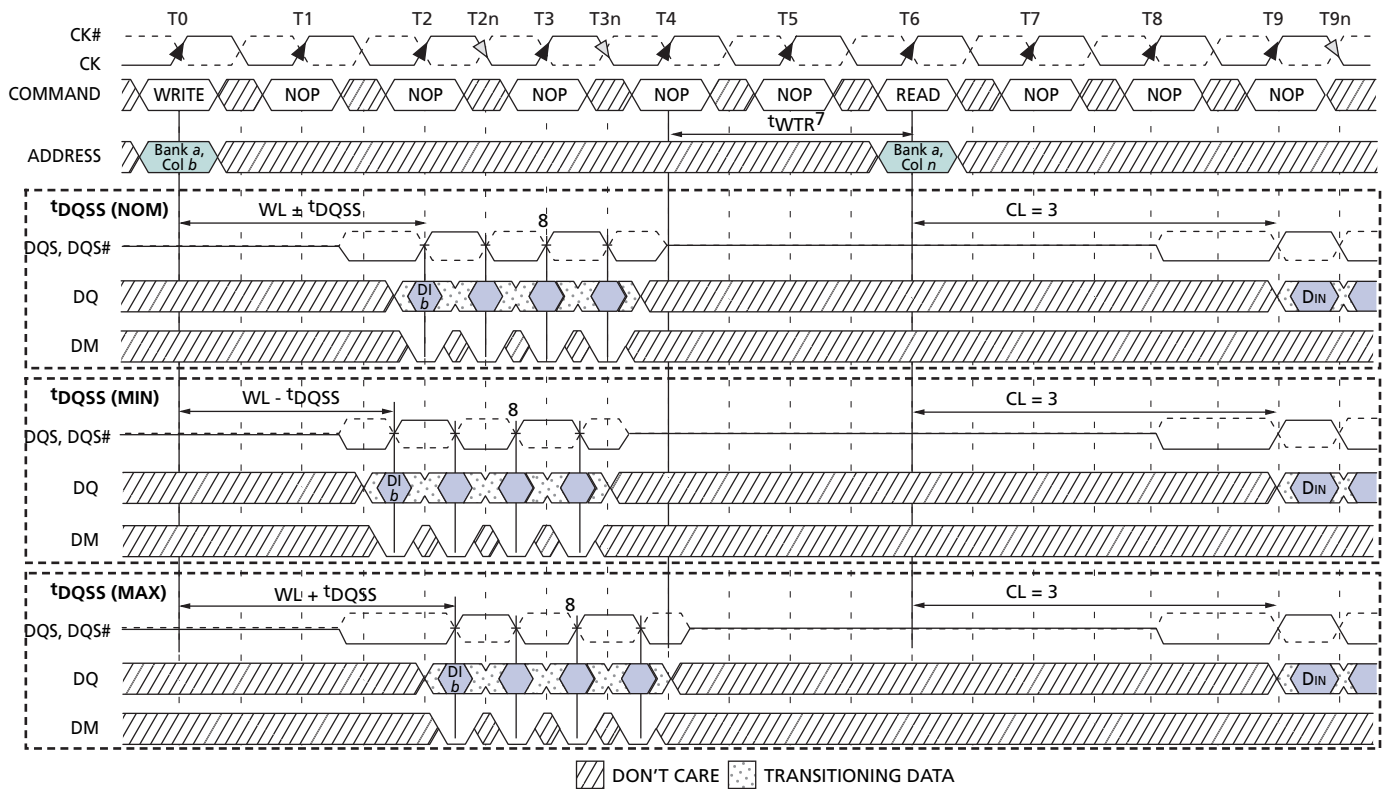

- Notes:
1. DI b = data-in for column b ; DOUT n = data-out from column n .
 2. BL = 4, AL = 0, CL = 3; thus, WL = 2.
 3. One subsequent element of data-in is applied in the programmed order following DI b .
 4. t_{WTR} is referenced from the first positive CK edge after the last data-in pair.
 5. A10 is LOW with the WRITE command (auto precharge is disabled).
 6. The number of clock cycles required to meet t_{WTR} is either 2 or t_{WTR}/t_{CK} , whichever is greater.
 7. t_{WTR} is required for any READ following a WRITE to the same device, but it is not required between module ranks.
 8. Subsequent rising DQS signals must align to the clock within t_{DQSS} .

Figure 41: WRITE-to-PRECHARGE

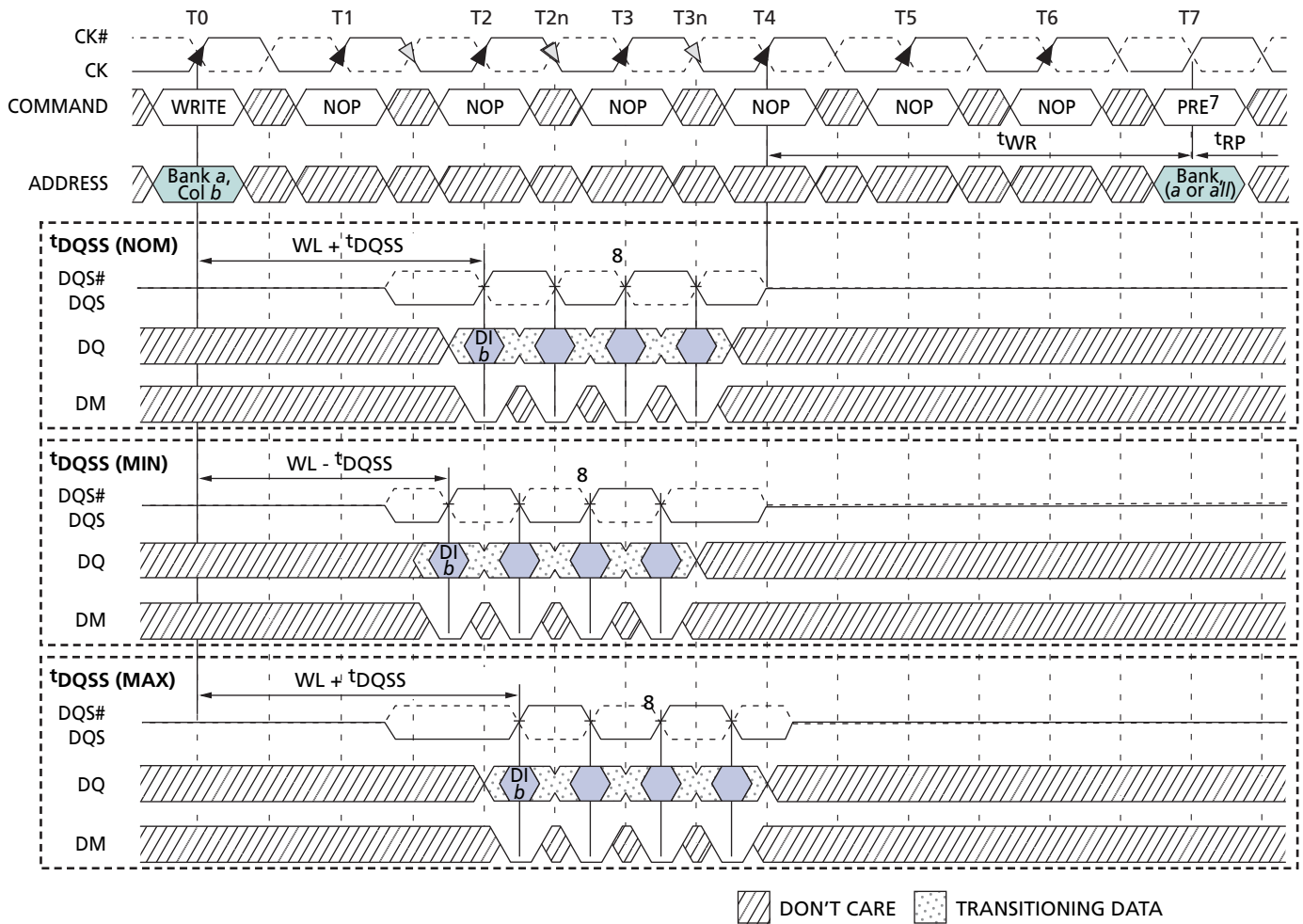

- Notes:
1. DI *b* = data-in for column *b*.
 2. Three subsequent elements of data-in are applied in the programmed order following DI *b*.
 3. BL = 4, CL = 3, AL = 0; thus, WL = 2.
 4. t_{WR} is referenced from the first positive CK edge after the last data-in pair.
 5. The PRECHARGE and WRITE commands are to the same bank. However, the PRECHARGE and WRITE commands may be to different banks, in which case t_{WR} is not required and the PRECHARGE command could be applied earlier.
 6. A10 is LOW with the WRITE command (auto precharge is disabled).
 7. PRE = PRECHARGE command.
 8. Subsequent rising DQS signals must align to the clock within t_{DQSS} .

Figure 42: Bank Write – without Auto Precharge

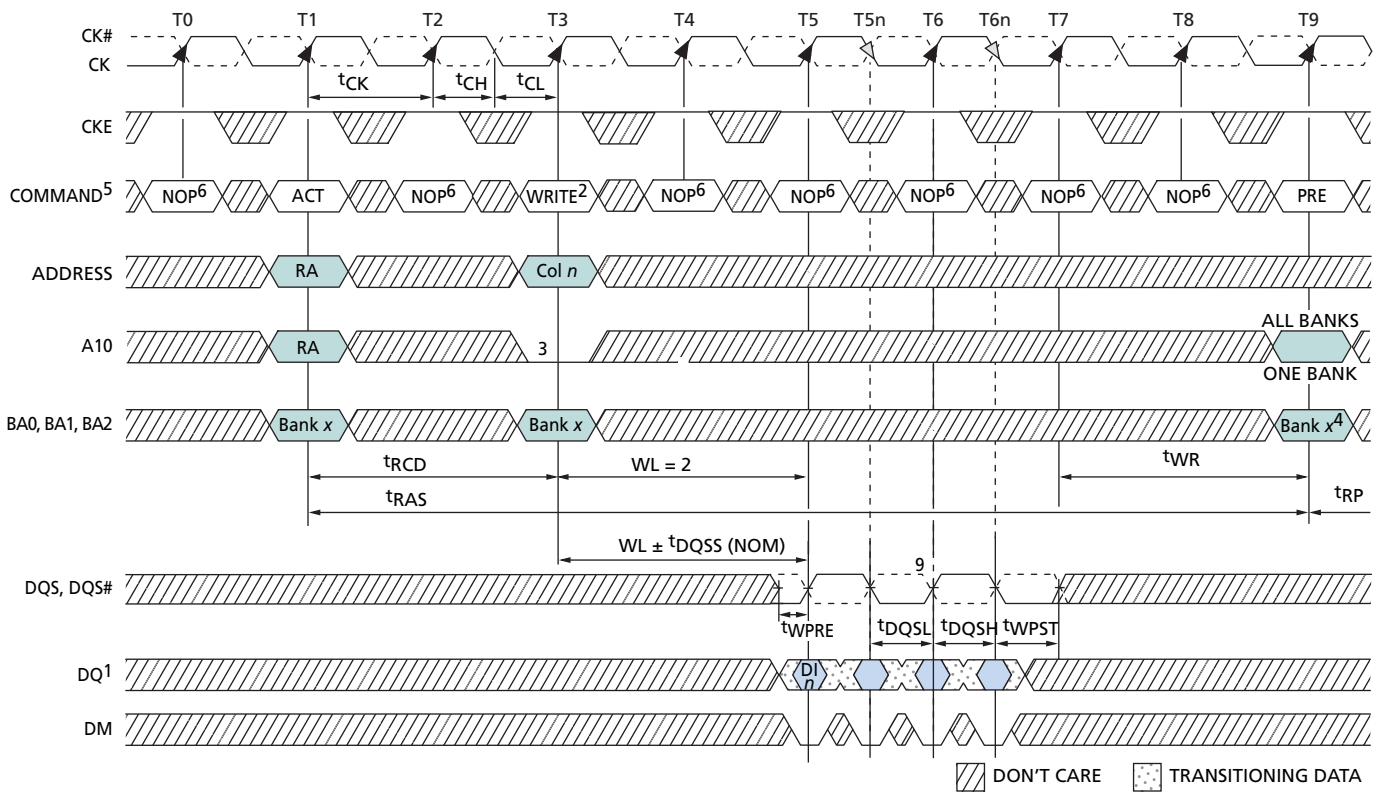

- Notes:
1. DI n = data-in from column n ; subsequent elements are applied in the programmed order.
 2. BL = 4, AL = 0, and WL = 2 in the case shown.
 3. Disable auto precharge.
 4. "Don't Care" if A10 is HIGH at T9.
 5. PRE = PRECHARGE, ACT = ACTIVE, RA = row address, BA = bank address.
 6. NOP commands are shown for ease of illustration; other commands may be valid at these times.
 7. t_{DSH} is applicable during t_{DQSS} (MIN) and is referenced from CK T5 or T6.
 8. t_{DSS} is applicable during t_{DQSS} (MAX) and is referenced from CK T6 or T7.
 9. Subsequent rising DQS signals must align to the clock within t_{DQSS} .

Figure 43: Bank Write – with Auto Precharge

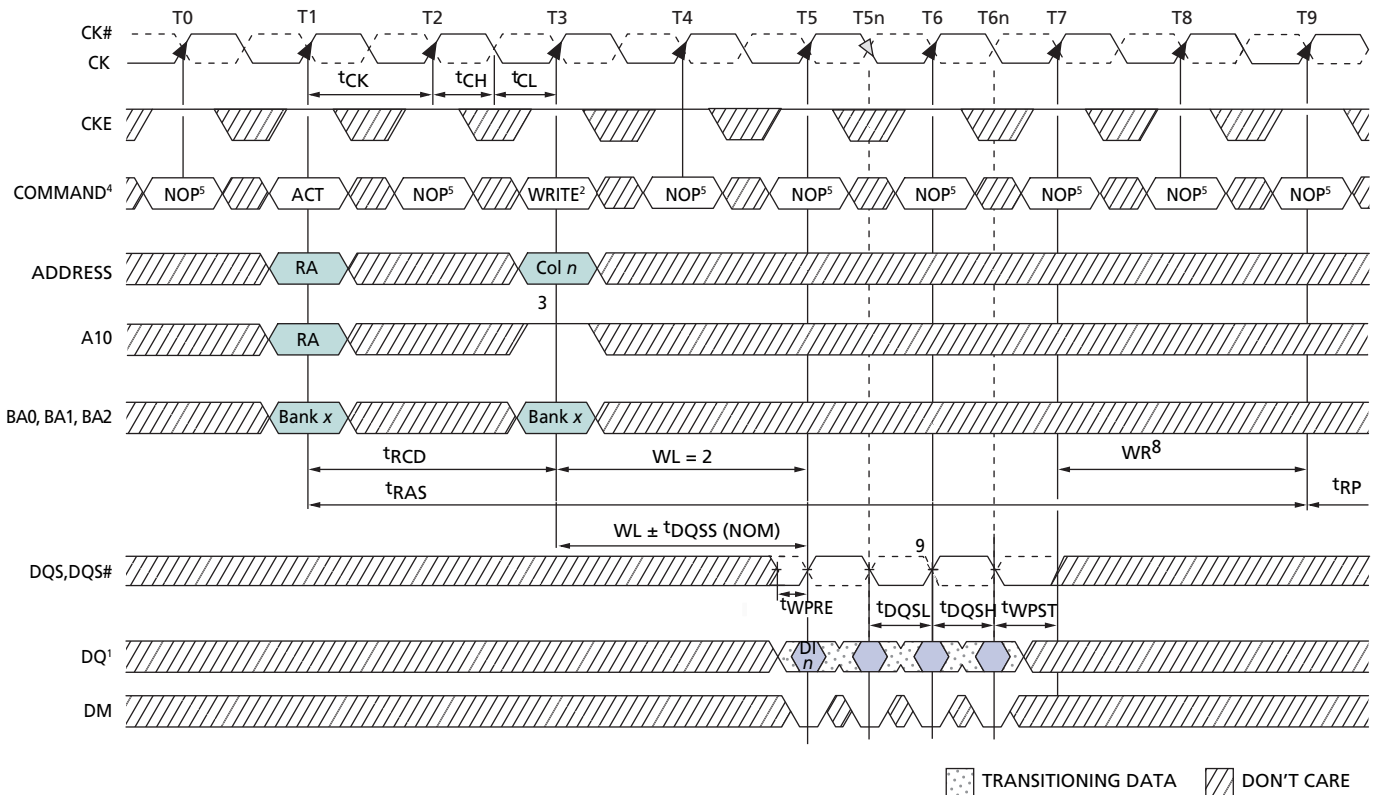

- Notes:
1. DI n = data-in from column n ; subsequent elements are applied in the programmed order.
 2. BL = 4, AL = 0, and WL = 2 in the case shown.
 3. Enable auto precharge.
 4. ACT = ACTIVE, RA = row address, BA = bank address.
 5. NOP commands are shown for ease of illustration; other commands may be valid at these times.
 6. t_{DSH} is applicable during t_{DQSS} (MIN) and is referenced from CK T5 or T6.
 7. t_{DSS} is applicable during t_{DQSS} (MAX) and is referenced from CK T6 or T7.
 8. WR is programmed via MR[11, 10, 9] and is calculated by dividing t_{WR} (in nanoseconds) by t_{CK} and rounding up to the next integer value.
 9. Subsequent rising DQS signals must align to the clock within t_{DQSS} .

Figure 44: WRITE – DM Operation

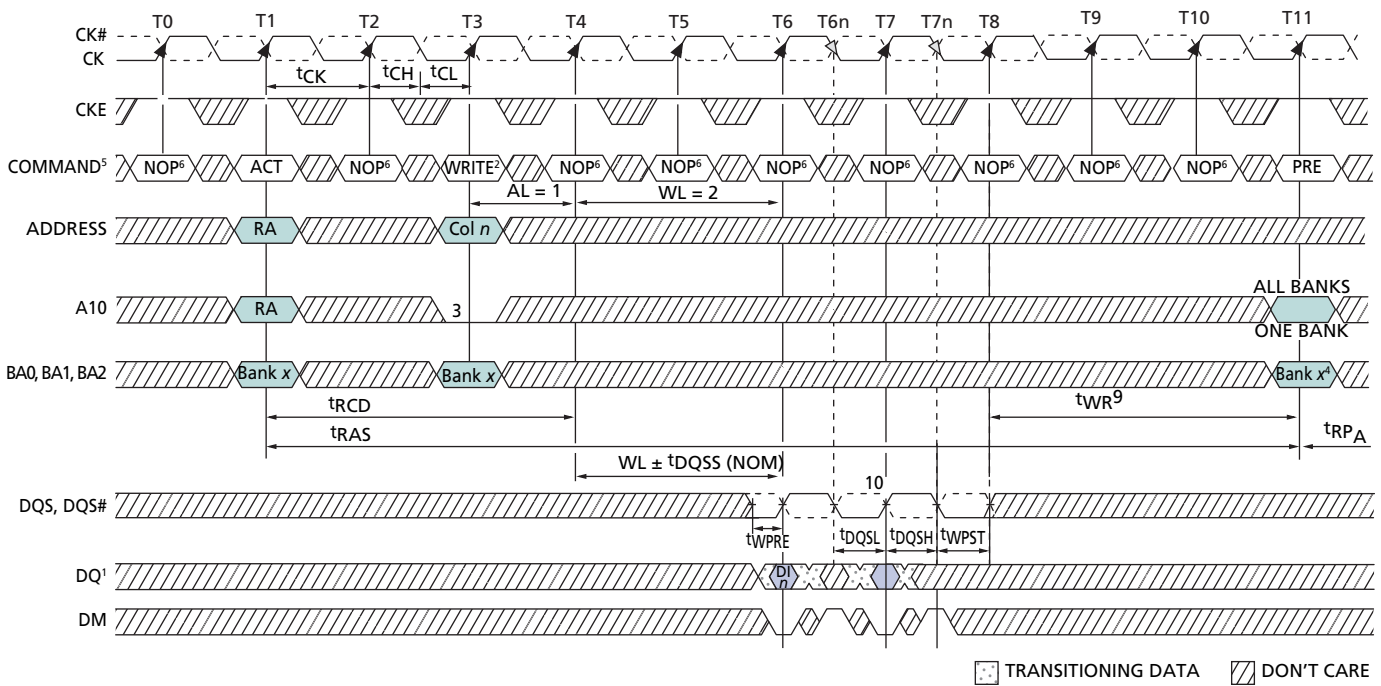

- Notes:
1. DI n = data-in from column n ; subsequent elements are applied in the programmed order.
 2. Burst length = 4, AL = 1, and WL = 2 in the case shown.
 3. Disable auto precharge.
 4. "Don't Care" if A10 is HIGH at T11.
 5. PRE = PRECHARGE, ACT = ACTIVE, RA = row address, BA = bank address.
 6. NOP commands are shown for ease of illustration; other commands may be valid at these times.
 7. t_{DSH} is applicable during t_{DQSS} (MIN) and is referenced from CK T6 or T7.
 8. t_{DSS} is applicable during t_{DQSS} (MAX) and is referenced from CK T7 or T8.
 9. t_{WR} starts at the end of the data burst regardless of the data mask condition.
 10. Subsequent rising DQS signals must align to the clock within t_{DQSS} .

Figure 45: Data Input Timing

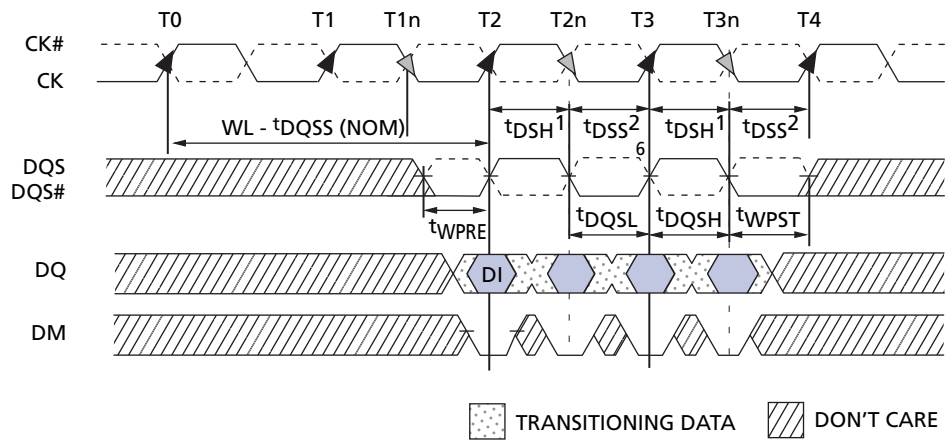

- Notes:
1. t_{DSH} (MIN) generally occurs during t_{DQSS} (MIN).
 2. t_{DSS} (MIN) generally occurs during t_{DQSS} (MAX).
 3. WRITE command issued at T0.
 4. For x16, LDQS controls the lower byte and UDQS controls the upper byte.
 5. WRITE command with WL = 2 (CL = 3, AL = 0) issued at T0.
 6. Subsequent rising DQS signals must align to the clock within t_{DQSS} .

PRECHARGE Command

The PRECHARGE command, illustrated in Figure 46, is used to deactivate the open row in a particular bank or the open row in all banks. The bank(s) will be available for a subsequent row activation a specified time (t_{RP}) after the PRECHARGE command is issued, except in the case of concurrent auto precharge, where a READ or WRITE command to a different bank is allowed as long as it does not interrupt the data transfer in the current bank and does not violate any other timing parameters. Once a bank has been precharged, it is in the idle state and must be activated prior to any READ or WRITE commands being issued to that bank. A PRECHARGE command is allowed if there is no open row in that bank (idle state) or if the previously open row is already in the process of precharging. However, the precharge period will be determined by the last PRECHARGE command issued to the bank.

PRECHARGE Operation

Input A10 determines whether one or all banks are to be precharged, and in the case where only one bank is to be precharged, inputs BA2–BA0 select the bank. Otherwise BA2–BA0 are treated as “Don’t Care.”

When all banks are to be precharged, inputs BA2–BA0 are treated as “Don’t Care.” Once a bank has been precharged, it is in the idle state and must be activated prior to any READ or WRITE commands being issued to that bank. t_{RPA} timing applies when the PRECHARGE (ALL) command is issued, regardless of the number of banks already open or closed. If a single-bank PRECHARGE command is issued, t_{RP} timing applies. t_{RPA} (MIN) applies to all 8-bank DDR2 devices.

Figure 46: PRECHARGE Command

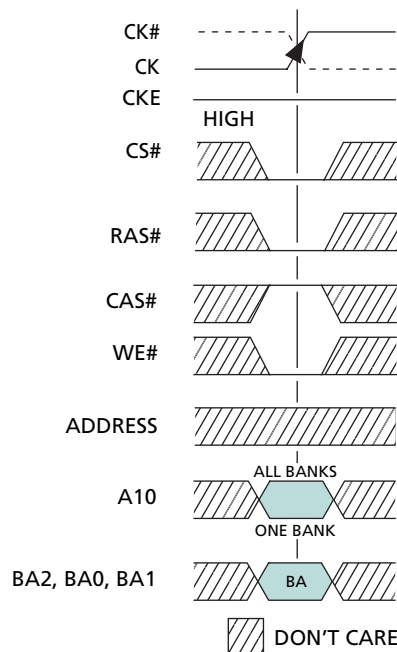

Note: BA = bank address (if A10 is LOW; otherwise “Don’t Care”).

SELF REFRESH Command

The SELF REFRESH command can be used to retain data in the DDR2 SDRAM, even if the rest of the system is powered down. When in the self refresh mode, the DDR2 SDRAM retains data without external clocking. All power supply inputs (including V_{REF}) must be maintained at valid levels upon entry/exit *and* during SELF REFRESH operation.

The SELF REFRESH command is initiated like a REFRESH command except CKE is LOW. The DLL is automatically disabled upon entering self refresh and is automatically enabled upon exiting self refresh (200 clock cycles must then occur before a READ command can be issued). The differential clock should remain stable and meet t_{CKE} specifications at least $1 \times t_{CK}$ after entering self refresh mode. All command and address input signals except CKE are “Don’t Care” during self refresh.

The procedure for exiting self refresh requires a sequence of commands. First, the differential clock must be stable and meet t_{CK} specifications at least $1 \times t_{CK}$ prior to CKE going back HIGH. Once CKE is HIGH ($t_{CKE} [MIN]$ has been satisfied with four clock registrations), the DDR2 SDRAM must have NOP or DESELECT commands issued for t_{XSNR} because time is required for the completion of any internal refresh in progress. A simple algorithm for meeting both refresh and DLL requirements is to apply NOP or DESELECT commands for 200 clock cycles before applying any other command.

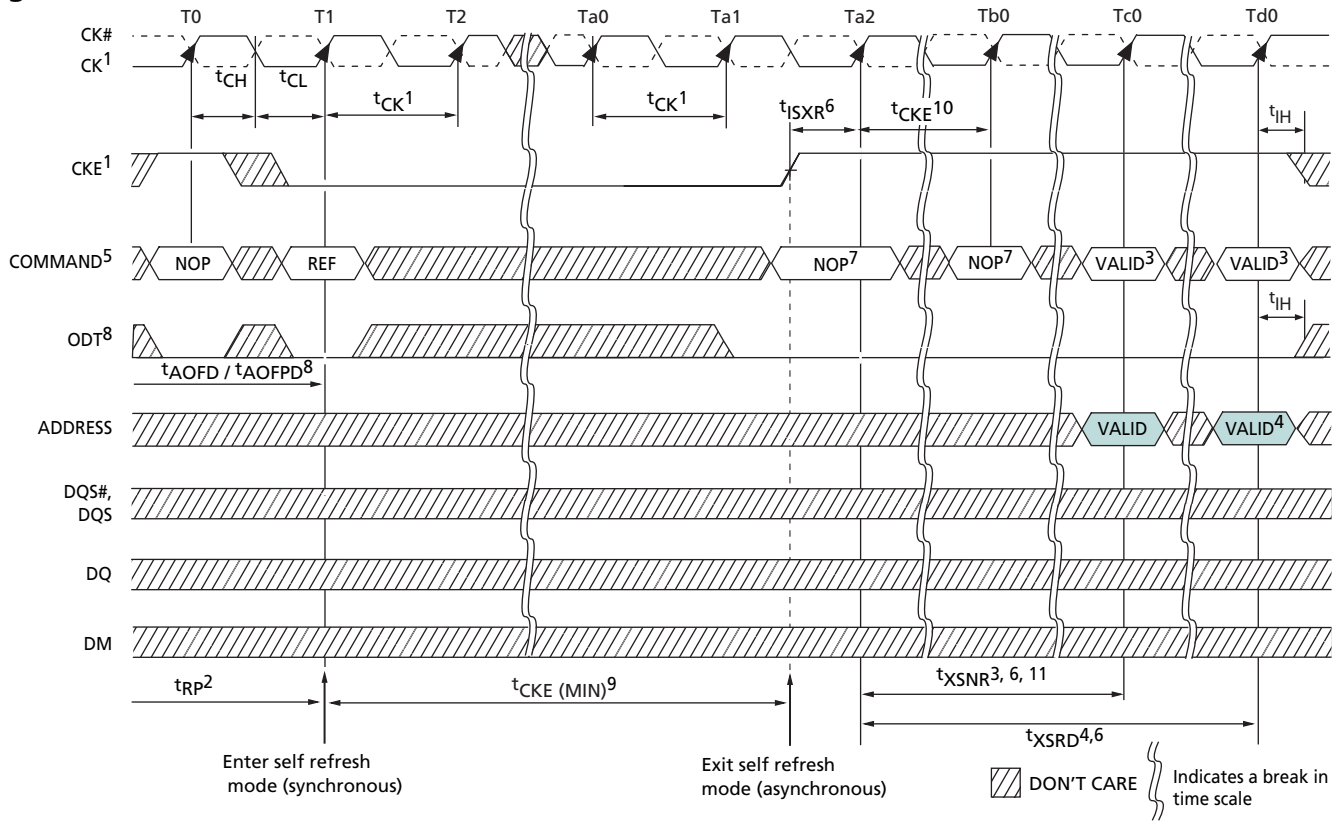
Figure 47: Self Refresh

- Notes:
1. Clock must be stable and meeting t_{CK} specifications at least $1 \times t_{CK}$ after entering self refresh mode and at least $1 \times t_{CK}$ prior to exiting self refresh mode.
 2. Device must be in the all banks idle state prior to entering self refresh mode.
 3. t_{XSNR} is required before any non-READ command can be applied.
 4. t_{XSRD} (200 cycles of CK) is required before a READ command can be applied at state Td0.
 5. REF = REFRESH command.
 6. Self refresh exit is asynchronous; however, t_{XSNR} and t_{XSRD} timing starts at the first rising clock edge where CKE HIGH satisfies t_{ISXR} .
 7. NOP or DESELECT commands are required prior to exiting self refresh until state Tc0, which allows any non-READ command.
 8. ODT must be disabled and RTT off (t_{AOFD} and t_{AOFDP} have been satisfied) prior to entering SELF REFRESH at state T1.
 9. Once self refresh has been entered, $t_{CKE (MIN)}$ must be satisfied prior to exiting self refresh.
 10. CKE must stay HIGH until t_{XSRD} is met; however, if self refresh is being re-entered, CKE may go back LOW after t_{XSNR} is satisfied.
 11. Once exiting SELF REFRESH, ODT must remain LOW until t_{XSRD} is satisfied.

REFRESH Command

REFRESH is used during normal operation of the DDR2 SDRAM and is analogous to CAS#-Before-RAS# (CBR) REFRESH. This command is nonpersistent, so it must be issued each time a refresh is required. The addressing is generated by the internal refresh controller. This makes the address bits a “Don’t Care” during an REFRESH command. The 1Gb DDR2 SDRAM requires REFRESH cycles at an average interval of 7.8125µs (MAX). To allow for improved efficiency in scheduling and switching between tasks, some flexibility in the absolute refresh interval is provided. A maximum of eight REFRESH commands can be posted (to defer issuing REFRESH commands) to any given DDR2 SDRAM, meaning that the maximum absolute interval between any REFRESH command and the next REFRESH command is $9 \times 7.8125\mu\text{s}$ (70.3µs; 3.9µs for high-temperature operation). The refresh period begins when the REFRESH command is registered and ends t_{RFC} (MIN) later.

Figure 48: Refresh Mode

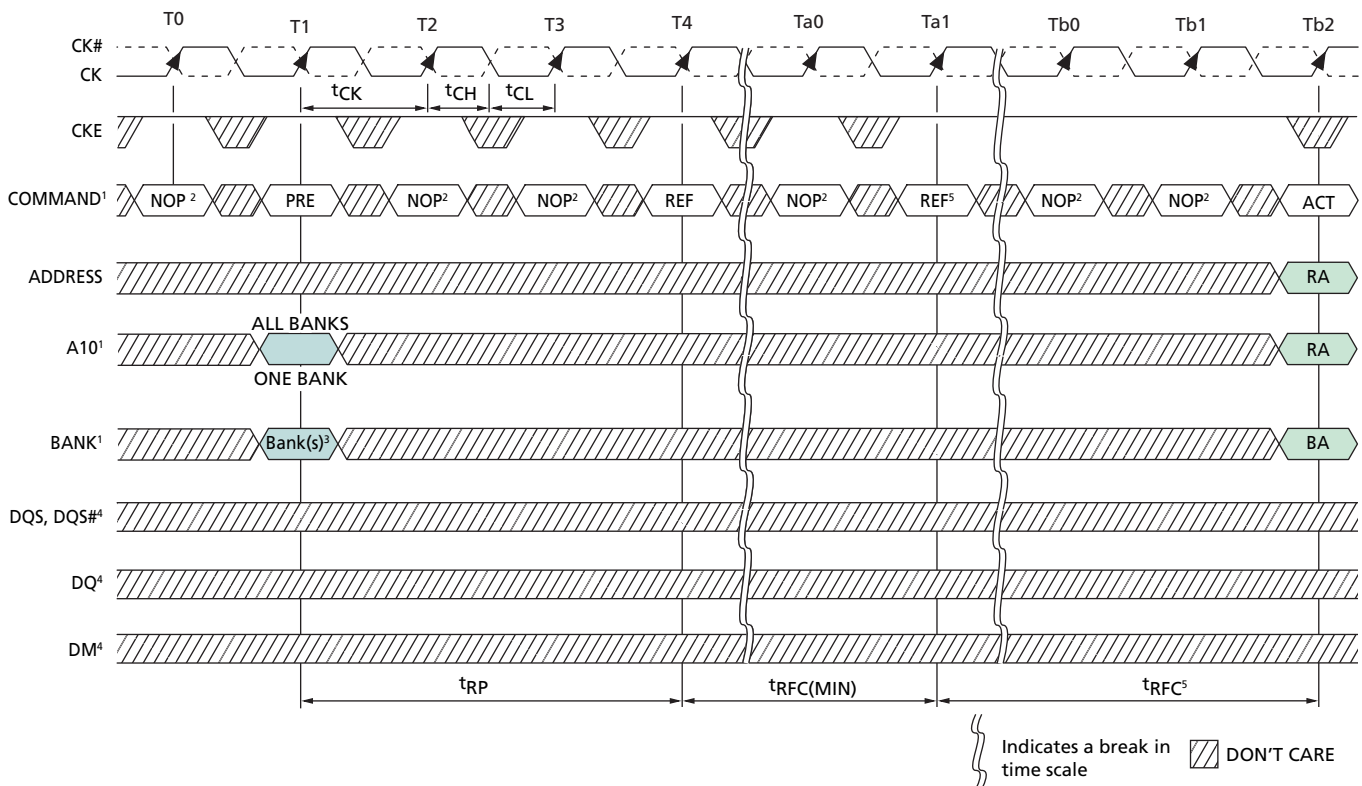

- Notes:
1. PRE = PRECHARGE, ACT = ACTIVE, AR = REFRESH, RA = row address, BA = bank address.
 2. NOP commands are shown for ease of illustration; other valid commands may be possible at these times. CKE must be active during clock positive transitions.
 3. “Don’t Care” if A10 is HIGH at this point; A10 must be HIGH if more than one bank is active (i.e., must precharge all active banks).
 4. DM, DQ, and DQS signals are all “Don’t Care”/High-Z for operations shown.
 5. The second REFRESH is not required and is only shown as an example of two back-to-back REFRESH commands.

Power-Down Mode

DDR2 SDRAMs support multiple power-down modes that allow significant power savings over normal operating modes. CKE is used to enter and exit different power-down modes. Power-down entry and exit timings are shown in Figure 49 on page 70. Detailed power-down entry conditions are shown in Figures 50 through 57. The CKE Truth Table, Table 12, is shown on page 71.

DDR2 SDRAMs require CKE to be registered HIGH (active) at all times that an access is in progress—from the issuing of a READ or WRITE command until completion of the burst. Thus, a clock suspend is not supported. For READs, a burst completion is defined when the read postamble is satisfied; for WRITEs, a burst completion is defined when the write postamble and t_{WR} or t_{WTR} are satisfied, as shown in Figures 52 and 53 on page 73. The number of clock cycles required to meet t_{WTR} is either two or t_{WTR}/t_{CK} , whichever is greater.

Power-down mode (see Figure 49 on page 70) is entered when CKE is registered LOW coincident with a NOP or DESELECT command. CKE is not allowed to go LOW during a mode register or extended mode register command time, or while a READ or WRITE operation is in progress. If power-down occurs when all banks are idle, this mode is referred to as precharge power-down. If power-down occurs when there is a row active in any bank, this mode is referred to as active power-down. Entering power-down deactivates the input and output buffers, excluding CK, CK#, ODT, and CKE. For maximum power savings, the DLL is frozen during precharge power-down. Exiting active power-down requires the device to be at the same voltage and frequency as when it entered power-down. Exiting precharge power-down requires the device to be at the same voltage as when it entered power-down; however, the clock frequency is allowed to change. See “Precharge Power-Down Clock Frequency Change” on page 76.

The maximum duration for either active or precharge power-down is limited by the refresh requirements of the device t_{RFC} (MAX). The minimum duration for power-down entry and exit is limited by the t_{CKE} (MIN) parameter. While in power-down mode, CKE LOW, a stable clock signal, and stable power supply signals must be maintained at the inputs of the DDR2 SDRAM, while all other input signals are “Don’t Care” except ODT. Detailed ODT timing diagrams for different power-down modes are shown in Figures 60 through 67.

The power-down state is synchronously exited when CKE is registered HIGH (in conjunction with an NOP or DESELECT command), as shown in Figure 49 on page 70.

Figure 49: Power-Down

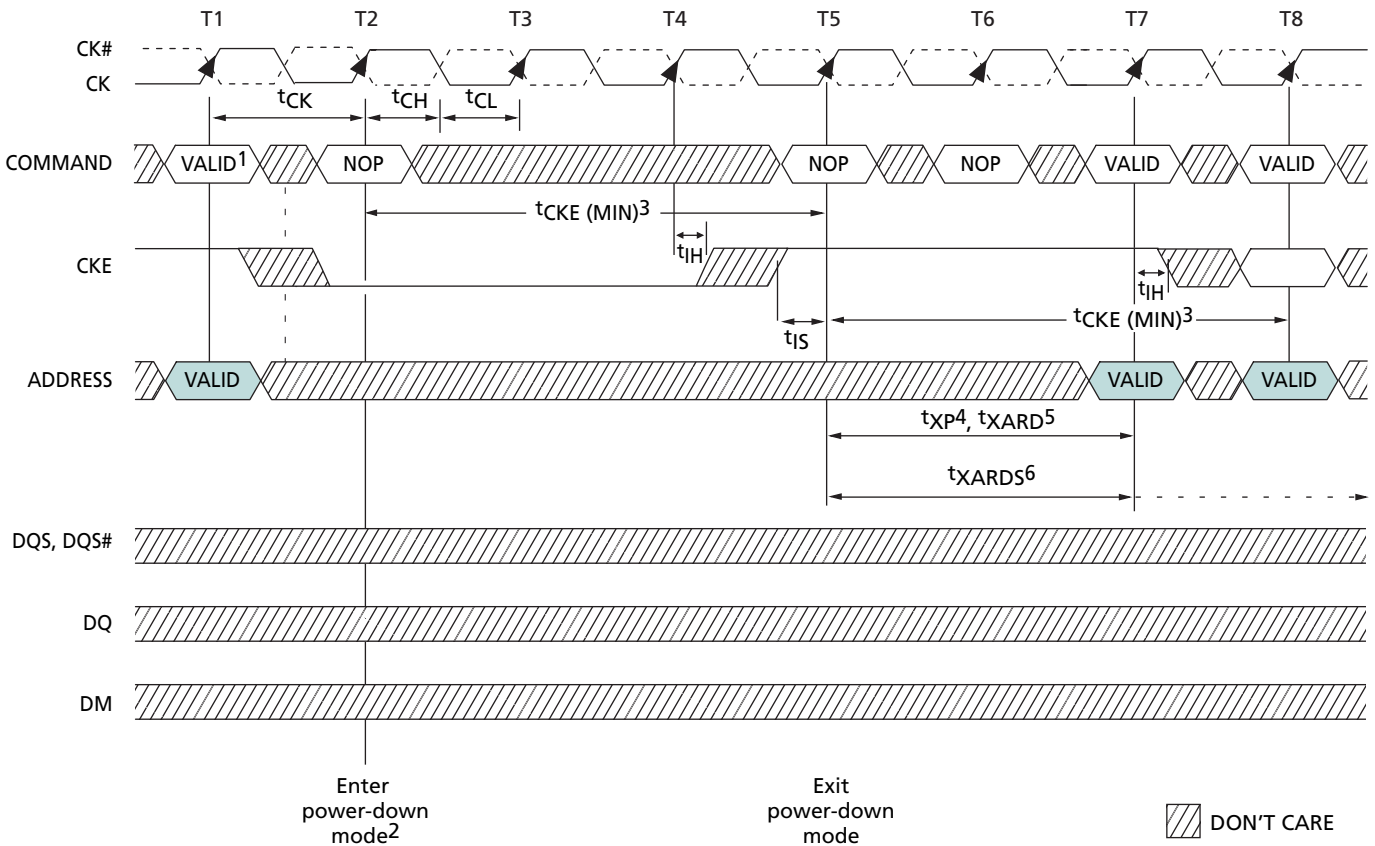

- Notes:
1. If this command is a PRECHARGE (or if the device is already in the idle state), then the power-down mode shown is precharge power-down. If this command is an ACTIVE (or if at least one row is already active), then the power-down mode shown is active power-down.
 2. No column accesses are allowed to be in progress at the time power-down is entered. If the DLL was not in a locked state when CKE went LOW, the DLL must be reset after exiting power-down mode for proper READ operation.
 3. $t_{CKE (MIN)}$ of three clocks means CKE must be registered on three consecutive positive clock edges. CKE must remain at the valid input level the entire time it takes to achieve the three clocks of registration. Thus, after any CKE transition, CKE may not transition from its valid level during the time period of $t_{IS} + 2 \times t_{CK} + t_{IH}$. CKE must not transition during its t_{IS} and t_{IH} window.
 4. t_{XP} timing is used for exit precharge power-down and active power-down to any non-READ command.
 5. t_{XARD} timing is used for exit active power-down to READ command if fast exit is selected via MR (bit 12 = 0).
 6. t_{XARDS} timing is used for exit active power-down to READ command if slow exit is selected via MR (bit 12 = 1).

Table 12: CKE Truth Table
Notes 1–3, 12

| Current State | CKE | | Command (n) CS#, RAS#, CAS#, WE# | Action (n) | Notes |
|----------------|----------------------|-------------------|--|----------------------------|--------------|
| | Previous Cycle (n-1) | Current Cycle (n) | | | |
| Power-down | L | L | X | Maintain power-down | 13, 14 |
| | L | H | DESELECT or NOP | Power-down exit | 4, 8 |
| Self refresh | L | L | X | Maintain self refresh | 14 |
| | L | H | DESELECT or NOP | Self refresh exit | 4, 5, 9 |
| Bank(s) active | H | L | DESELECT or NOP | Active power-down entry | 4, 8, 10, 11 |
| All banks idle | H | L | DESELECT or NOP | Precharge power-down entry | 4, 8, 10 |
| | H | L | REFRESH | Self refresh entry | 6, 9, 11 |
| | H | H | Shown in Table 6 on page 34 | | 7 |

- Notes:
1. CKE (n) is the logic state of CKE at clock edge n; CKE (n-1) was the state of CKE at the previous clock edge.
 2. Current state is the state of the DDR2 SDRAM immediately prior to clock edge n.
 3. Command (n) is the command registered at clock edge n, and action (n) is a result of command (n).
 4. All states and sequences not shown are illegal or reserved unless explicitly described elsewhere in this document.
 5. On self refresh exit, DESELECT or NOP commands must be issued on every clock edge occurring during the t_{XSNR} period. READ commands may be issued only after t_{XSRD} (200 clocks) is satisfied.
 6. Self refresh mode can only be entered from the all banks idle state.
 7. Must be a legal command, as defined in Table 6 on page 34.
 8. Valid commands for power-down entry and exit are NOP and DESELECT only.
 9. Valid commands for self refresh exit are NOP and DESELECT only.
 10. Power-down and self refresh can not be entered while READ or WRITE operations, LOAD MODE operations, or PRECHARGE operations are in progress. See "Power-Down Mode" on page 69 and See "SELF REFRESH Command" on page 66 for a list of detailed restrictions.
 11. Minimum CKE HIGH time is $t_{CKE} = 3 \times t_{CK}$. Minimum CKE LOW time is $t_{CKE} = 3 \times t_{CK}$. This requires a minimum of 3 clock cycles of registration.
 12. The state of ODT does not affect the states described in this table. The ODT function is not available during self refresh. See "ODT Timing" on page 79 for more details and specific restrictions.
 13. Power-down modes do not perform any REFRESH operations. The duration of power-down mode is therefore limited by the refresh requirements.
 14. "X" means "Don't Care" (including floating around V_{REF}) in self refresh and power-down. However, ODT must be driven HIGH or LOW in power-down if the ODT function is enabled via EMR(1).

Figure 50: READ to Power-Down or Self Refresh Entry

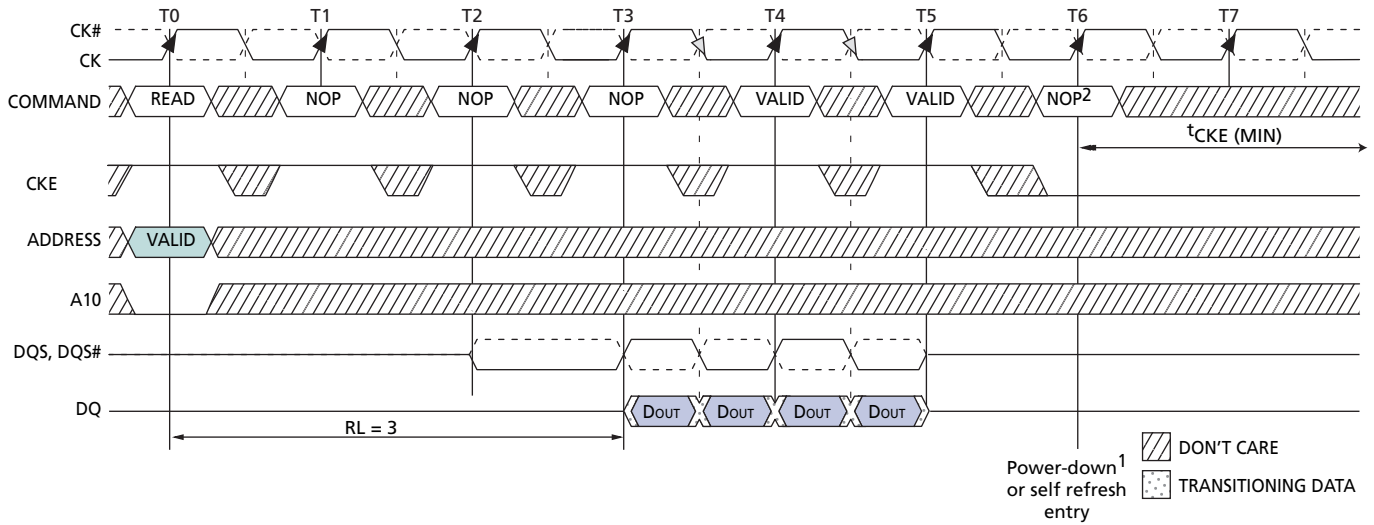

- Notes:
1. Power-down or self refresh entry may occur after the READ burst completes.
 2. In the example shown, READ burst completes at T5; earliest power-down or self refresh entry is at T6.

Figure 51: READ with Auto Precharge to Power-Down or Self Refresh Entry

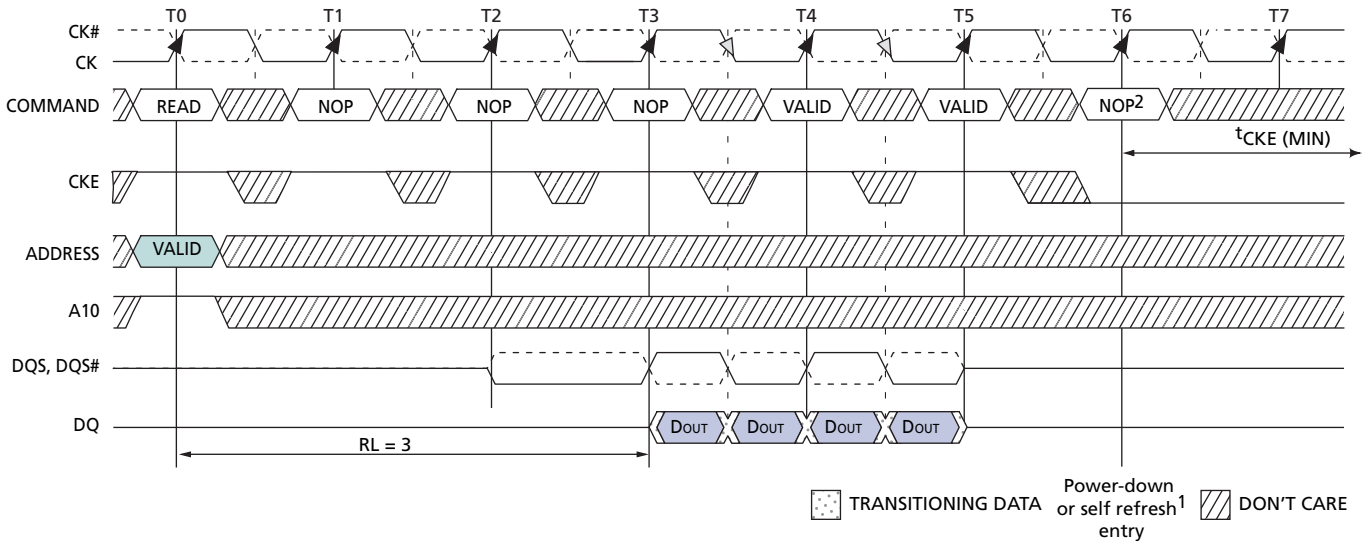

- Notes:
1. Power-down or self refresh entry may occur after the READ burst completes.
 2. In the example shown, READ burst completes at T5; earliest power-down or self refresh entry is at T6.

Figure 52: WRITE to Power-Down or Self-Refresh Entry

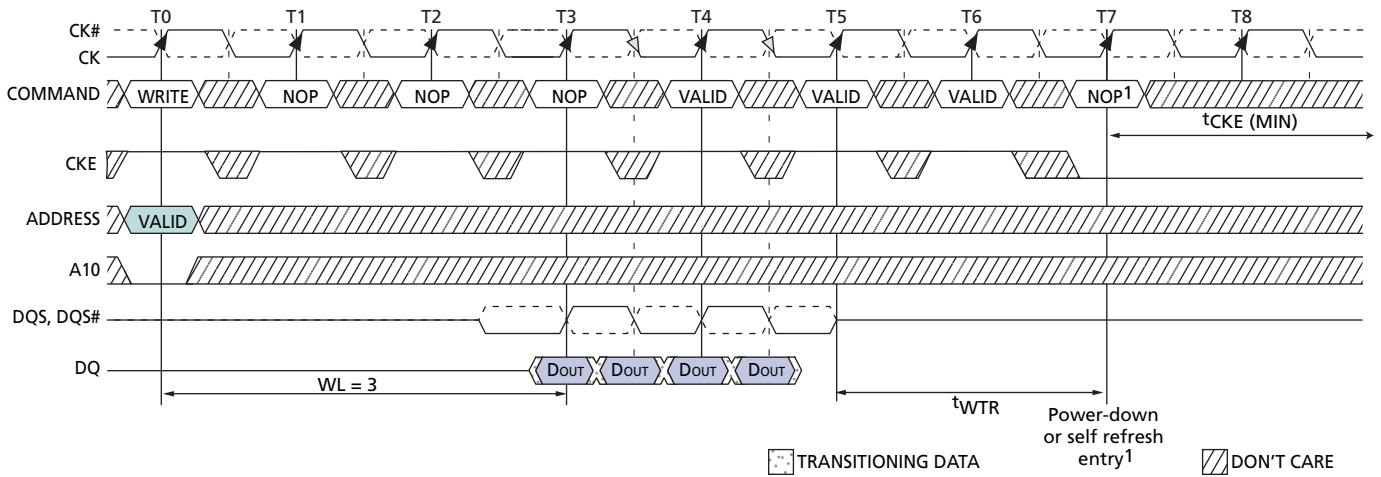

Notes: 1. Power-down or self refresh entry may occur after the WRITE burst completes.

Figure 53: WRITE with Auto Precharge to Power-Down or Self Refresh Entry

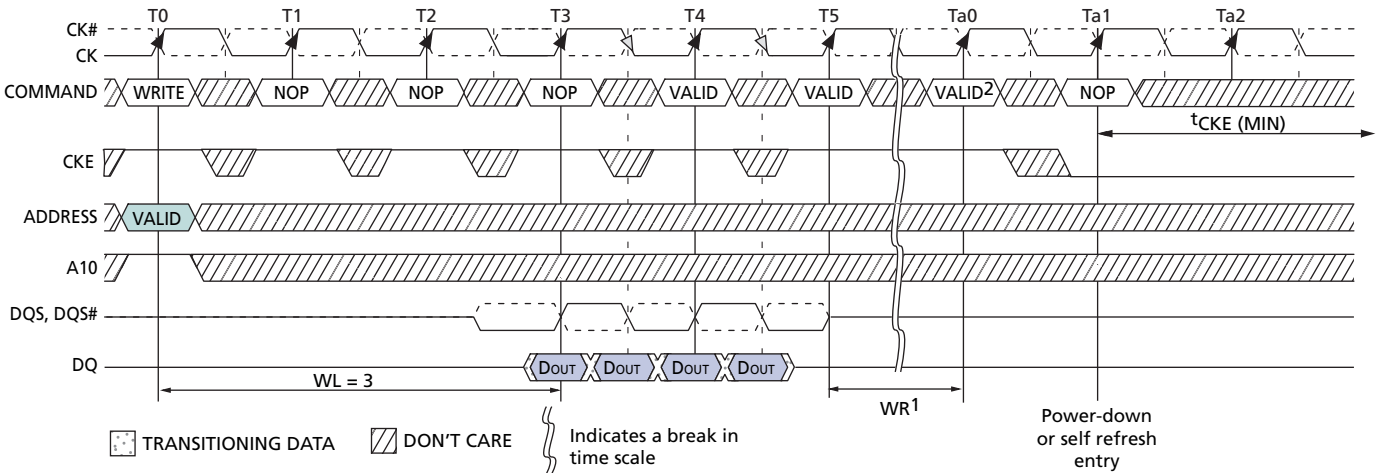

Notes: 1. WR is programmed through MR[9, 10, 11] and represents ($t_{WR} [MIN] \text{ ns} / t_{CK}$) rounded up to next integer t_{CK} .
2. Internal PRECHARGE occurs at Ta0 when WR has completed; power-down entry may occur $1 \times t_{CK}$ later at Ta1, prior to t_{RP} being satisfied.

Figure 54: REFRESH Command to Power-Down Entry

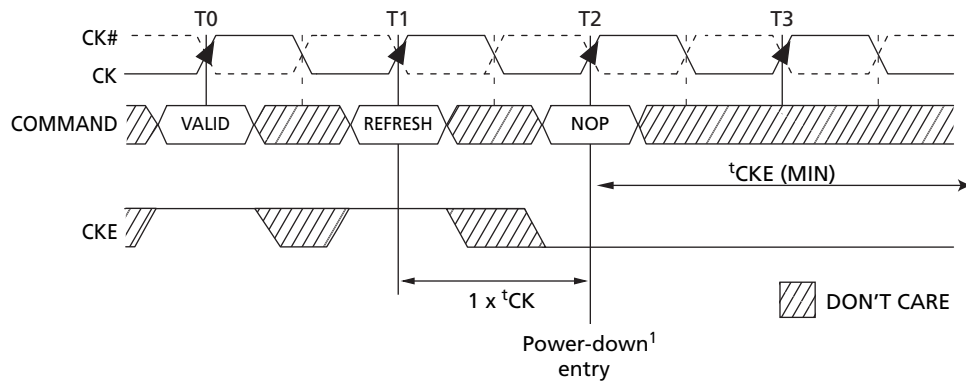

Notes: 1. The earliest precharge power-down entry may occur is at T2 which is $1 \times t_{CK}$ after the REFRESH command. Precharge power down entry occurs prior to $t_{RFC} (MIN)$ being satisfied.

Figure 55: ACTIVE Command to Power-Down Entry

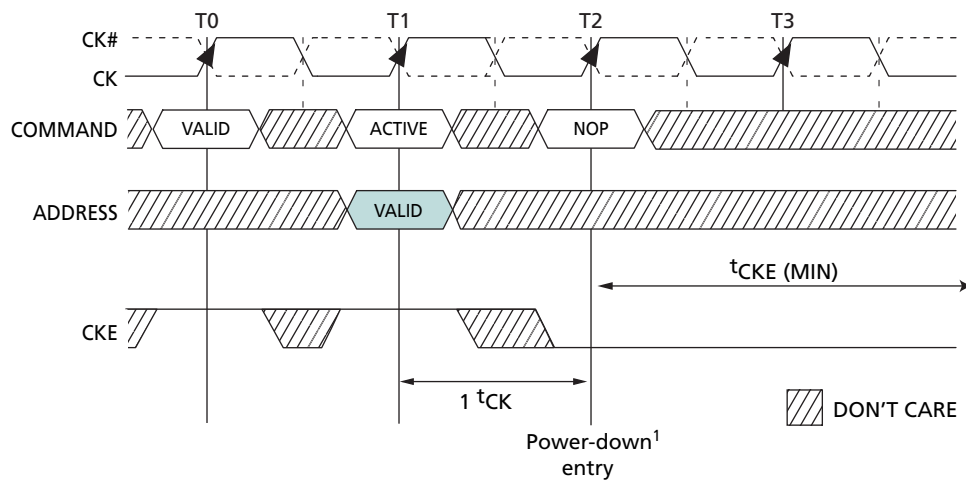

Notes: 1. The earliest active power-down entry may occur is at T2, which is $1 \times t_{CK}$ after the ACTIVE command. Active power-down entry occurs prior to $t_{RCD} (MIN)$ being satisfied.

Figure 56: PRECHARGE Command to Power-Down Entry

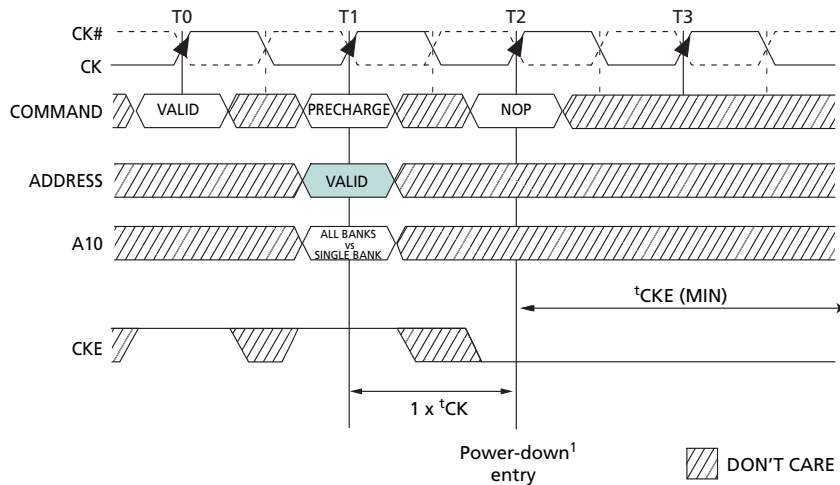

- Notes: 1. The earliest precharge power-down entry may occur is at T2, which is $1 \times t_{CK}$ after the PRECHARGE command. Precharge power-down entry occurs prior to $t_{RP}(\text{MIN})$ being satisfied.

Figure 57: LOAD MODE Command to Power-Down Entry

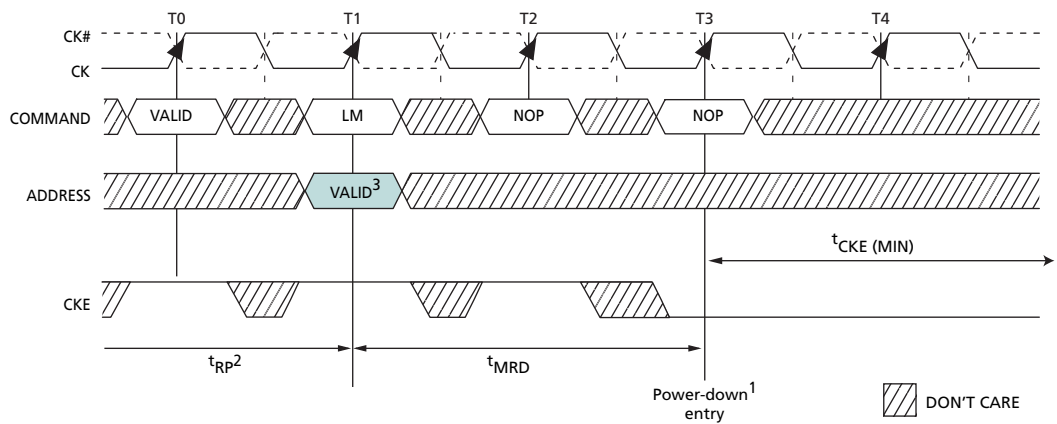

- Notes: 1. The earliest precharge power-down entry is at T3, which is after t_{MRD} is satisfied.
2. All banks must be in the precharged state and t_{RP} met prior to issuing LM command.
3. Valid address for LM command includes MR, EMR, EMR(2), and EMR(3) registers.

Precharge Power-Down Clock Frequency Change

When the DDR2 SDRAM is in precharge power-down mode, ODT must be turned off and CKE must be at a logic LOW level. A minimum of two differential clock cycles must pass after CKE goes LOW before clock frequency may change. The device input clock frequency is allowed to change only within minimum and maximum operating frequencies specified for the particular speed grade. During input clock frequency change, ODT and CKE must be held at stable LOW levels. Once the input clock frequency is changed, new stable clocks must be provided to the device before precharge power-down may be exited, and DLL must be reset via EMR after precharge power-down exit. Depending on the new clock frequency, an additional LM command might be required to appropriately set the WR MR[11, 10, 9]. During the DLL relock period of 200 cycles, ODT must remain off. After the DLL lock time, the DRAM is ready to operate with a new clock frequency.

Figure 58: Input Clock Frequency Change During Precharge Power-Down Mode

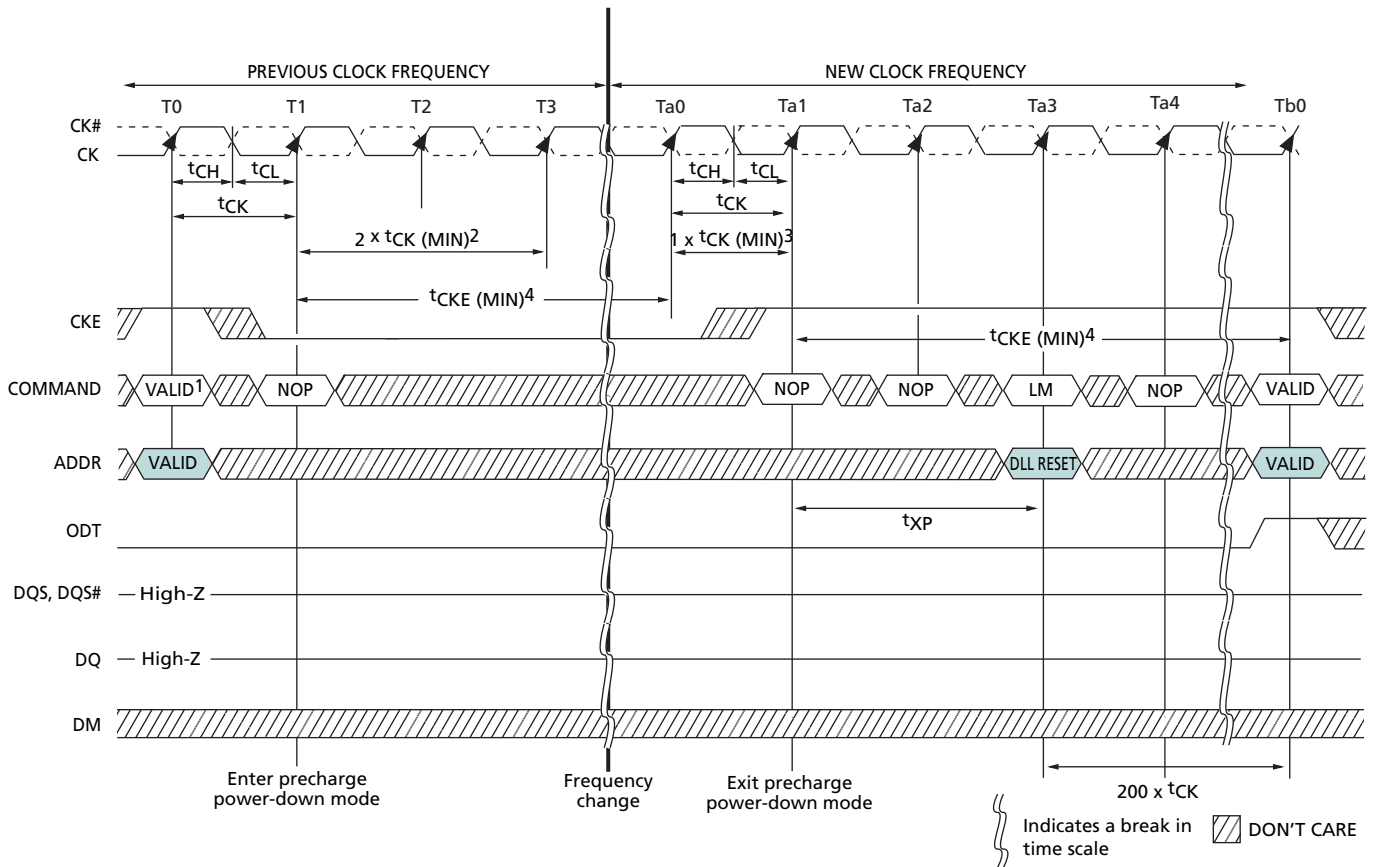

- Notes:
1. If this command is a PRECHARGE (or if the device is already in the idle state), then the power-down mode shown is precharge power-down, which is required prior to the clock frequency change.
 2. A minimum of $2 \times t_{CK}$ is required after entering precharge power-down prior to changing clock frequencies.
 3. Once the new clock frequency has changed and is stable, a minimum of $1 \times t_{CK}$ is required prior to exiting precharge power-down.
 4. Minimum CKE HIGH time is $t_{CKE} = 3 \times t_{CK}$. Minimum CKE LOW time is $t_{CKE} = 3 \times t_{CK}$. This requires a minimum of three clock cycles of registration.

RESET Function

(CKE LOW Anytime)

DDR2 SDRAM applications may go into a reset state anytime during normal operation. If an application enters a reset condition, CKE is used to ensure the DDR2 SDRAM device resumes normal operation after re-initializing. All data will be lost during a reset condition; however, the DDR2 SDRAM device will continue to operate properly if the following conditions outlined in this section are satisfied.

The reset condition defined here assumes all supply voltages (V_{DD} , V_{DDQ} , V_{DDL} , and V_{REF}) are stable and meet all DC specifications prior to, during, and after the RESET operation. All other input pins of the DDR2 SDRAM device are a “Don’t Care” during RESET with the exception of CKE.

If CKE asynchronously drops LOW during any valid operation (including a READ or WRITE burst), the memory controller must satisfy the timing parameter t_{DELAY} before turning off the clocks. Stable clocks must exist at the CK, CK# inputs of the DRAM before CKE is raised HIGH, at which time the normal initialization sequence must occur. See “Initialization” on page 21. The DDR2 SDRAM device is now ready for normal operation after the initialization sequence. Figure 59 on page 78 shows the proper sequence for a RESET operation.

Figure 59: RESET Function

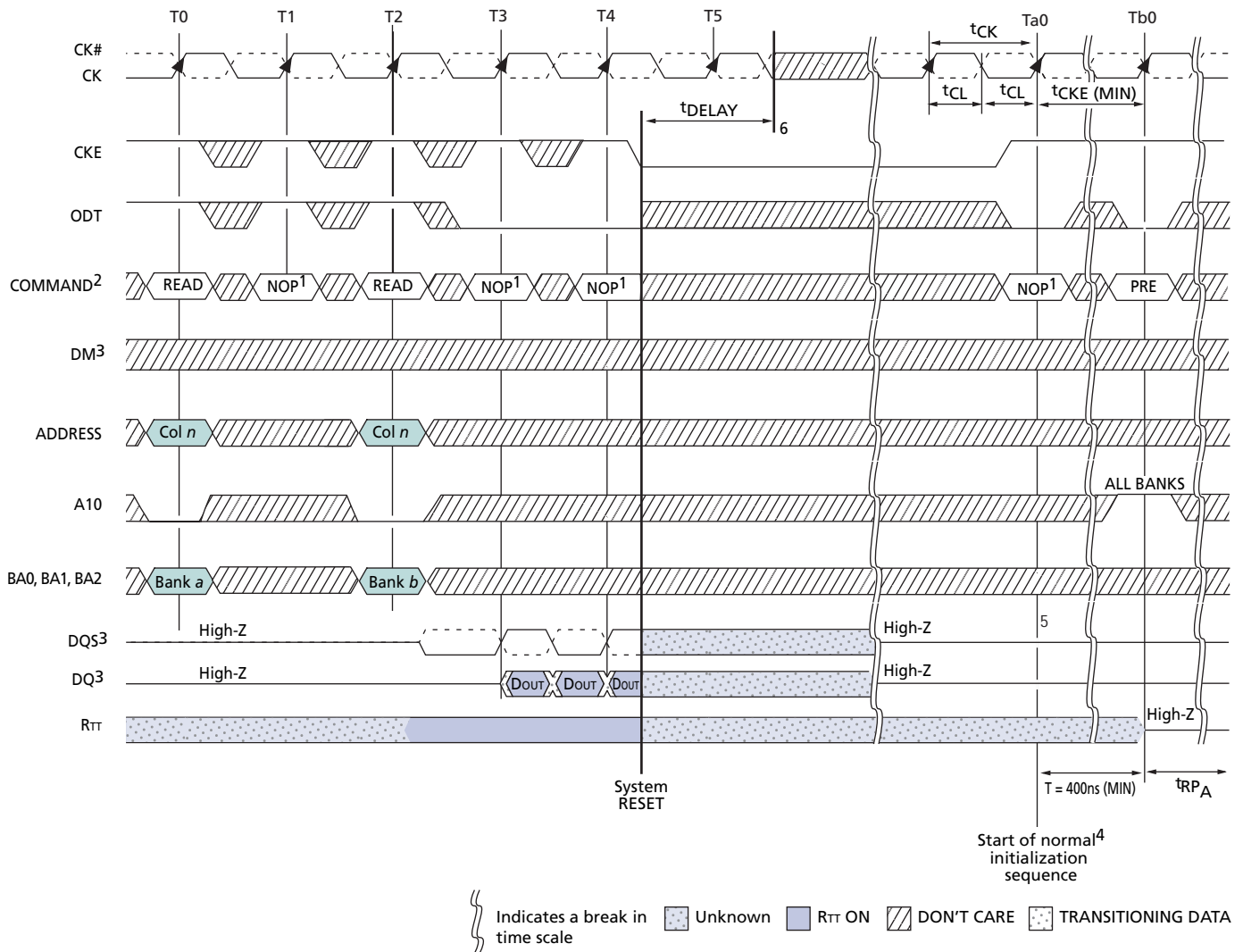

- Notes:
1. Either NOP or DESELECT command may be applied.
 2. PRE = PRECHARGE command.
 3. DM represents DM for x4/x8 configuration and UDM, LDM for x16 configuration. DQS represents DQS, DQS#, UDQS, UDQS#, LDQS, LDQS#, RDQS, RDQS# for the appropriate configuration (x4, x8, x16).
 4. Initialization timing is shown in Figure 10 on page 21.
 5. In certain cases where a READ cycle is interrupted, CKE going HIGH may result in the completion of the burst.
 6. VDD, VDDL, VDDQ, VTT, and VREF must be valid at all times.

ODT Timing

Once a 12ns delay (t_{MOD}) has been satisfied, and after the ODT function has been enabled via the EMR LOAD MODE command, ODT can be accessed under two timing categories. ODT will operate in either synchronous mode or asynchronous mode, depending on the state of CKE. ODT can switch anytime except during self refresh mode and a few clocks after being enabled via EMR, as shown in Figure 60 on page 80.

There are two timing categories for ODT—turn-on and turn-off. During active mode (CKE HIGH) and fast-exit power-down mode (any row of any bank open, CKE LOW, MR[12 = 0]), t_{AOND} , t_{AON} , t_{AOFD} , and t_{AOF} timing parameters are applied, as shown in Figure 62 on page 81 and Table 13 on page 81.

During slow-exit power-down mode (any row of any bank open, CKE LOW, MR[12] = 1) and precharge power-down mode (all banks/rows precharged and idle, CKE LOW), t_{AONPD} and t_{AOFPD} timing parameters are applied, as shown in Figure 63 on page 82 and Table 14 on page 82.

ODT turn-off timing, prior to entering any power-down mode, is determined by the parameter t_{ANPD} (MIN), as shown in Figure 64 on page 83. At state T2, the ODT HIGH signal satisfies t_{ANPD} (MIN) prior to entering power-down mode at T5. When t_{ANPD} (MIN) is satisfied, t_{AOFD} and t_{AOF} timing parameters apply. Figure 64 on page 83 also shows the example where t_{ANPD} (MIN) is *not* satisfied since ODT HIGH does not occur until state T3. When t_{ANPD} (MIN) is *not* satisfied, t_{AOFPD} timing parameters apply.

ODT turn-on timing prior to entering any power-down mode is determined by the parameter t_{ANPD} , as shown in Figure 65 on page 84. At state T2, the ODT HIGH signal satisfies t_{ANPD} (MIN) prior to entering power-down mode at T5. When t_{ANPD} (MIN) is satisfied, t_{AOND} and t_{AON} timing parameters apply. Figure 65 also shows the example where t_{ANPD} (MIN) is *not* satisfied since ODT HIGH does not occur until state T3. When t_{ANPD} (MIN) is *not* satisfied, t_{AONPD} timing parameters apply.

ODT turn-off timing after exiting any power-down mode is determined by the parameter t_{AXPD} (MIN), as shown in Figure 66 on page 85. At state Ta1, the ODT LOW signal satisfies t_{AXPD} (MIN) after exiting power-down mode at state T1. When t_{AXPD} (MIN) is satisfied, t_{AOFD} and t_{AOF} timing parameters apply. Figure 66 also shows the example where t_{AXPD} (MIN) is *not* satisfied since ODT LOW occurs at state Ta0. When t_{AXPD} (MIN) is *not* satisfied, t_{AOFPD} timing parameters apply.

ODT turn-on timing after exiting either slow-exit power-down mode or precharge power-down mode is determined by the parameter t_{AXPD} (MIN), as shown in Figure 67 on page 86. At state Ta1, the ODT HIGH signal satisfies t_{AXPD} (MIN) after exiting power-down mode at state T1. When t_{AXPD} (MIN) is satisfied, t_{AOND} and t_{AON} timing parameters apply. Figure 67 also shows the example where t_{AXPD} (MIN) is *not* satisfied since ODT HIGH occurs at state Ta0. When t_{AXPD} (MIN) is *not* satisfied, t_{AONPD} timing parameters apply.

Figure 60: ODT Timing for Entering and Exiting Power-Down Mode

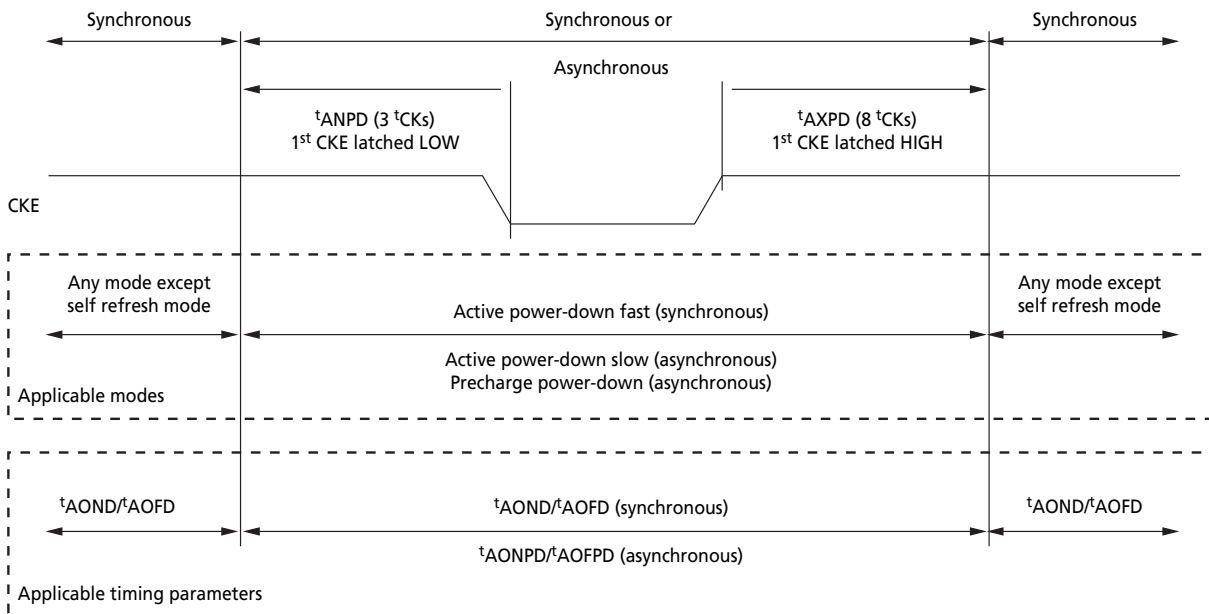

MRS Command to ODT Update Delay

During normal operation, the value of the effective termination resistance can be changed with an EMRS set command. t_{MOD} (MAX) updates the R_{TT} setting.

Figure 61: Timing for MRS Command to ODT Update Delay

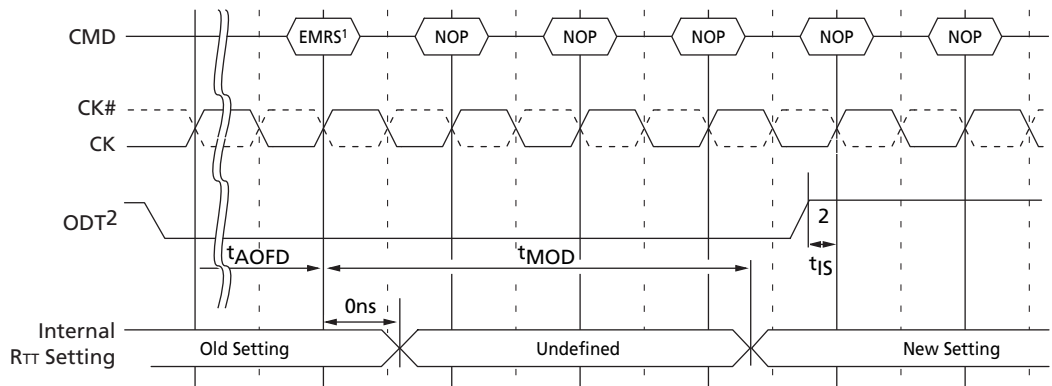

- Notes:
1. LM command directed to mode register, which updates the information in EMR(1)[A6, A2], i.e., R_{TT} (nominal).
 2. To prevent any impedance glitch on the channel, the following conditions must be met: t_{AOFD} must be met before issuing the LM command; ODT must remain LOW for the entire duration of the t_{MOD} window, until t_{MOD} is met.

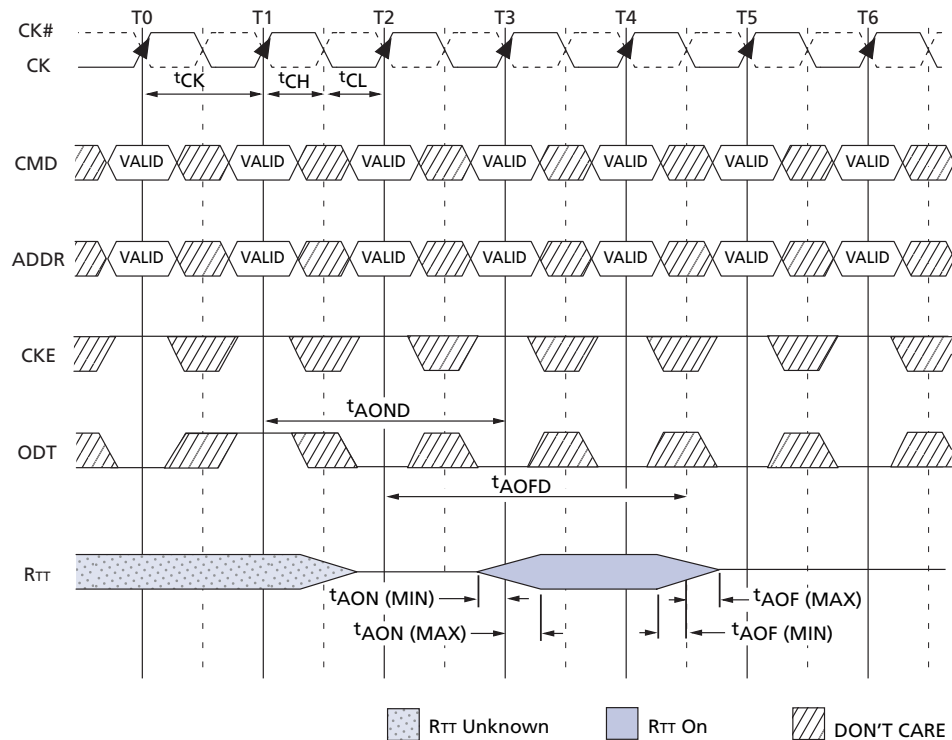
Figure 62: ODT Timing for Active or Fast-Exit Power-Down Mode

Table 13: DDR2-400/533 ODT Timing for Active and Fast-Exit Power-Down Modes

| Parameter | Symbol | Min | Max | Units |
|--------------------|------------|----------------|------------------------|----------|
| ODT turn-on delay | t_{AOND} | 2 | 2 | t_{CK} |
| ODT turn-on | t_{AON} | $t_{AC} (MIN)$ | $t_{AC} (MAX) + 1,000$ | ps |
| ODT turn-off delay | t_{AOFD} | 2.5 | 2.5 | t_{CK} |
| ODT turn-off | t_{AOF} | $t_{AC} (MIN)$ | $t_{AC} (MAX) + 600$ | ps |

Note: The half-clock of t_{AOFD} 's 2.5 t_{CK} assumes a 50/50 clock duty cycle. This half-clock value must be derated by the amount of half-clock duty cycle error. For example, if the clock duty cycle was 47/53, t_{AOFD} would actually be 2.5 - 0.03, or 2.47, for $t_{AOF} (MIN)$ and 2.5 + 0.03, or 2.53, for $t_{AOF} (MAX)$.

Figure 63: ODT Timing for Slow-Exit or Precharge Power-Down Modes

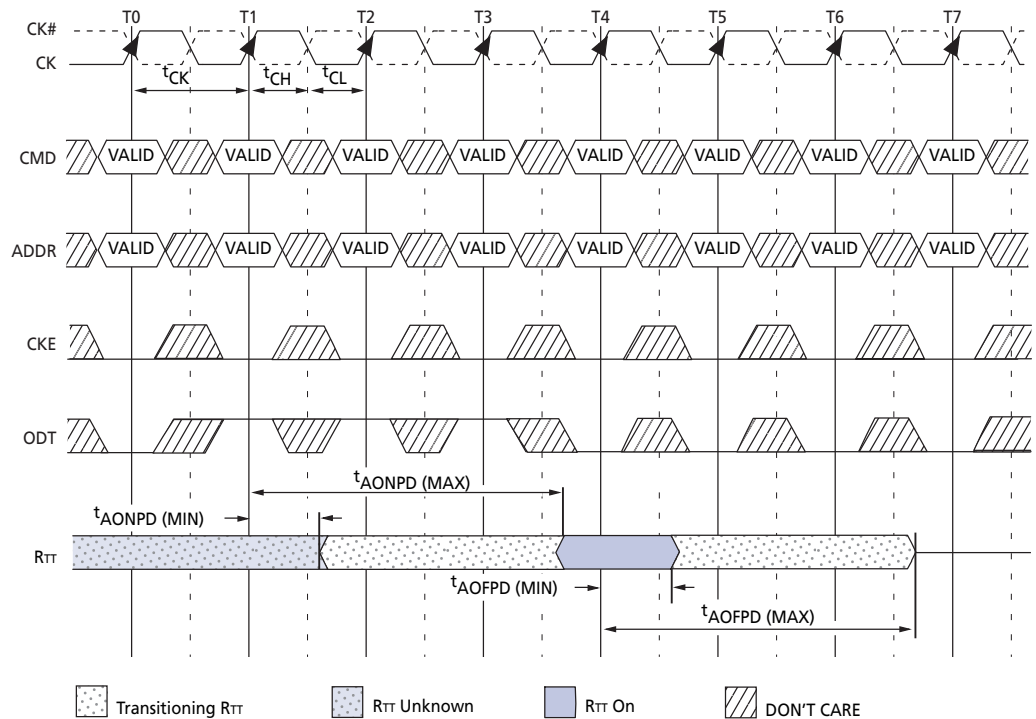
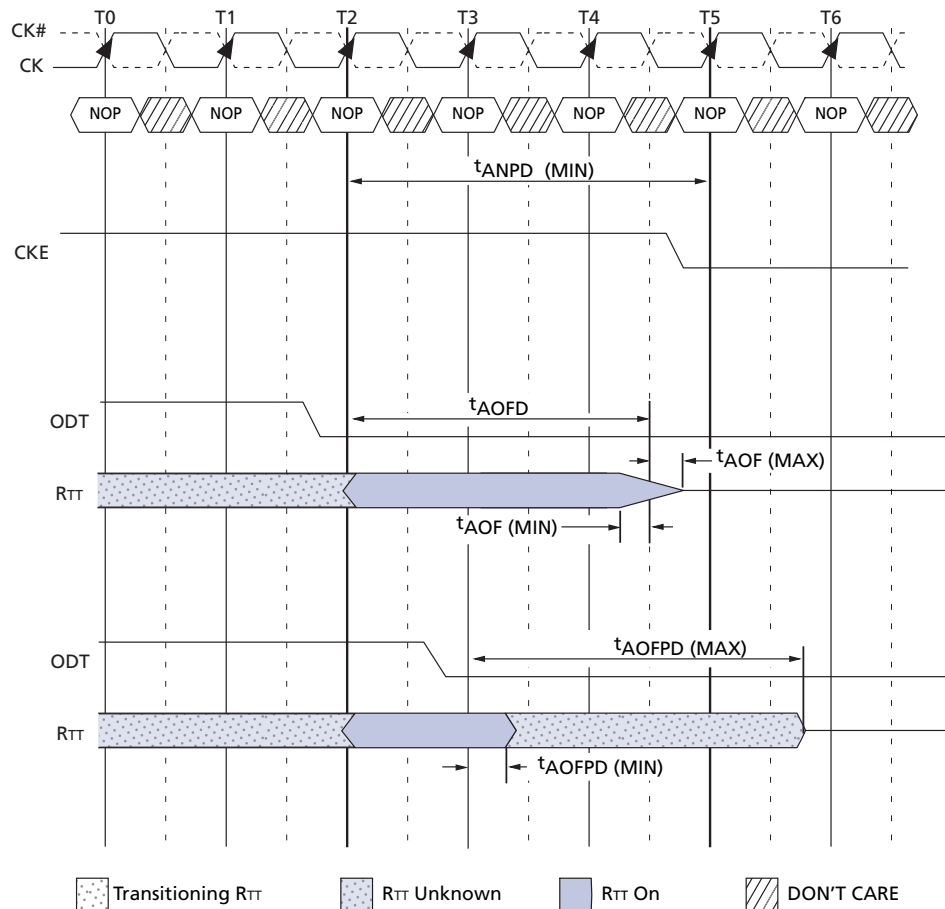

Table 14: DDR2-400/533 ODT Timing for Slow-Exit and Precharge Power-Down Modes

| Parameter | Symbol | Min | Max | Units |
|--------------------------------|-------------|------------------------|--|-------|
| ODT turn-on (power-down mode) | t_{AONPD} | $t_{AC} (MIN) + 2,000$ | $2 \times t_{CK} + t_{AC} (MAX) + 1,000$ | ps |
| ODT turn-off (power-down mode) | t_{AOFPD} | $t_{AC} (MIN) + 2,000$ | $2.5 \times t_{CK} + t_{AC} (MAX) + 1,000$ | ps |

Figure 64: ODT Turn-off Timings When Entering Power-Down Mode

Table 15: DDR2-400/533 ODT Turn-off Timings When Entering Power-Down Mode

| Parameter | Symbol | Min | Max | Units |
|---------------------------------|-------------|------------------------|--|----------|
| ODT turn-off delay | t_{AOFD} | 2.5 | 2.5 | t_{CK} |
| ODT turn-off | t_{AOF} | $t_{AC} (MIN)$ | $t_{AC} (MAX) + 600$ | ps |
| ODT turn-off (power-down mode) | t_{AOFPD} | $t_{AC} (MIN) + 2,000$ | $2.5 \times t_{CK} + t_{AC} (MAX) + 1,000$ | ps |
| ODT to power-down entry latency | t_{ANPD} | 3 | | t_{CK} |

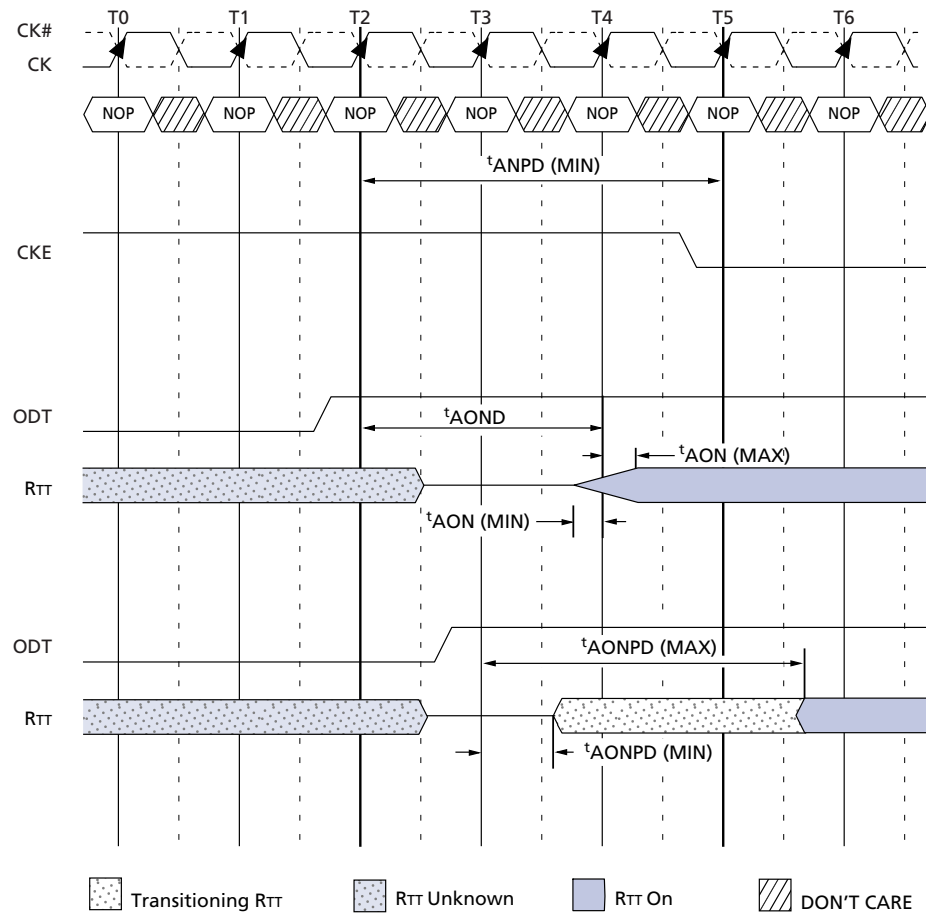
Note: The half-clock of t_{AOFD} 's $2.5 t_{CK}$ assumes a 50/50 clock duty cycle. This half-clock value must be derated by the amount of half-clock duty cycle error. For example, if the clock duty cycle was 47/53, t_{AOFD} would actually be $2.5 - 0.03$, or 2.47, for $t_{AOF} (MIN)$ and $2.5 + 0.03$, or 2.53, for $t_{AOF} (MAX)$.

Figure 65: ODT Turn-On Timing When Entering Power-Down Mode

Table 16: DDR2-400/533 ODT Turn-on Timing When Entering Power-Down Mode

| Parameter | Symbol | Min | Max | Units |
|---------------------------------|-------------|------------------------|--|----------|
| ODT turn-on delay | t_{AOND} | 2 | 2 | t_{CK} |
| ODT turn-on | t_{AON} | $t_{AC} (MIN)$ | $t_{AC} (MAX) + 1,000$ | ps |
| ODT turn-on (power-down mode) | t_{AONPD} | $t_{AC} (MIN) + 2,000$ | $2 \times t_{CK} + t_{AC} (MAX) + 1,000$ | ps |
| ODT to power-down entry latency | t_{ANPD} | 3 | | t_{CK} |

Figure 66: ODT Turn-Off Timing When Exiting Power-Down Mode

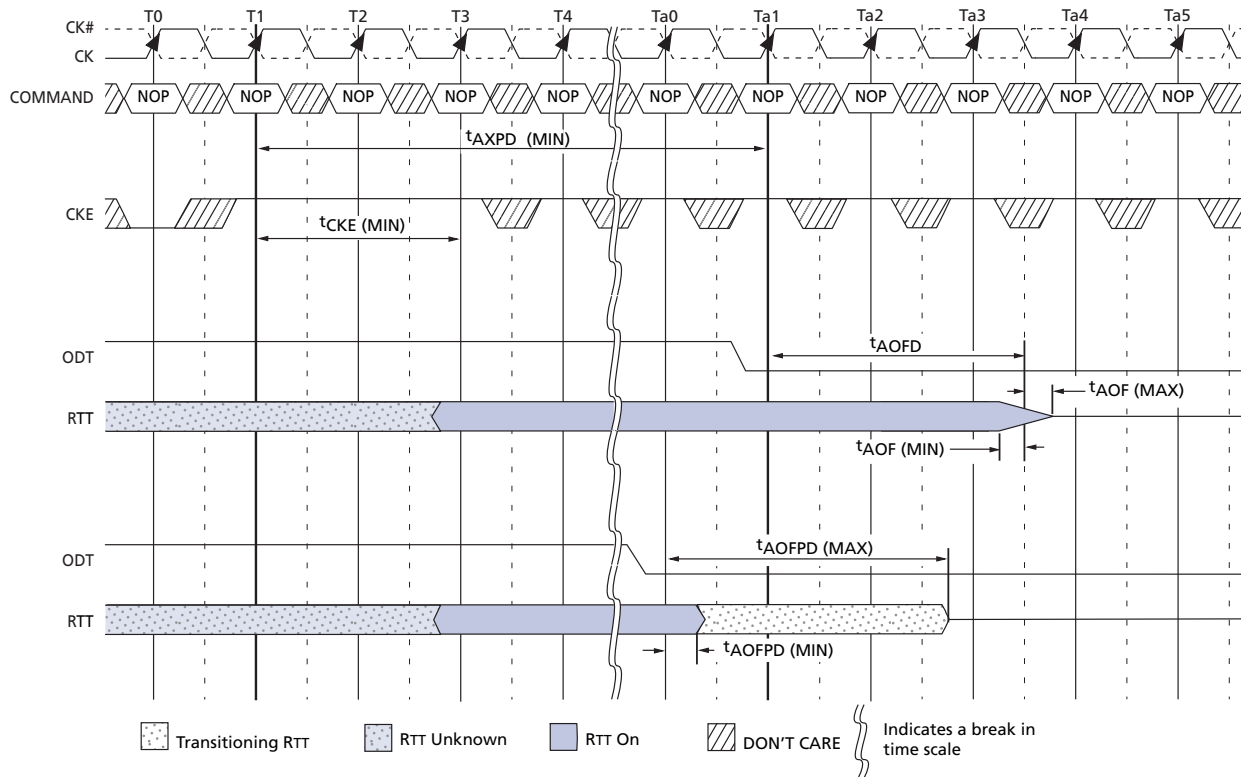
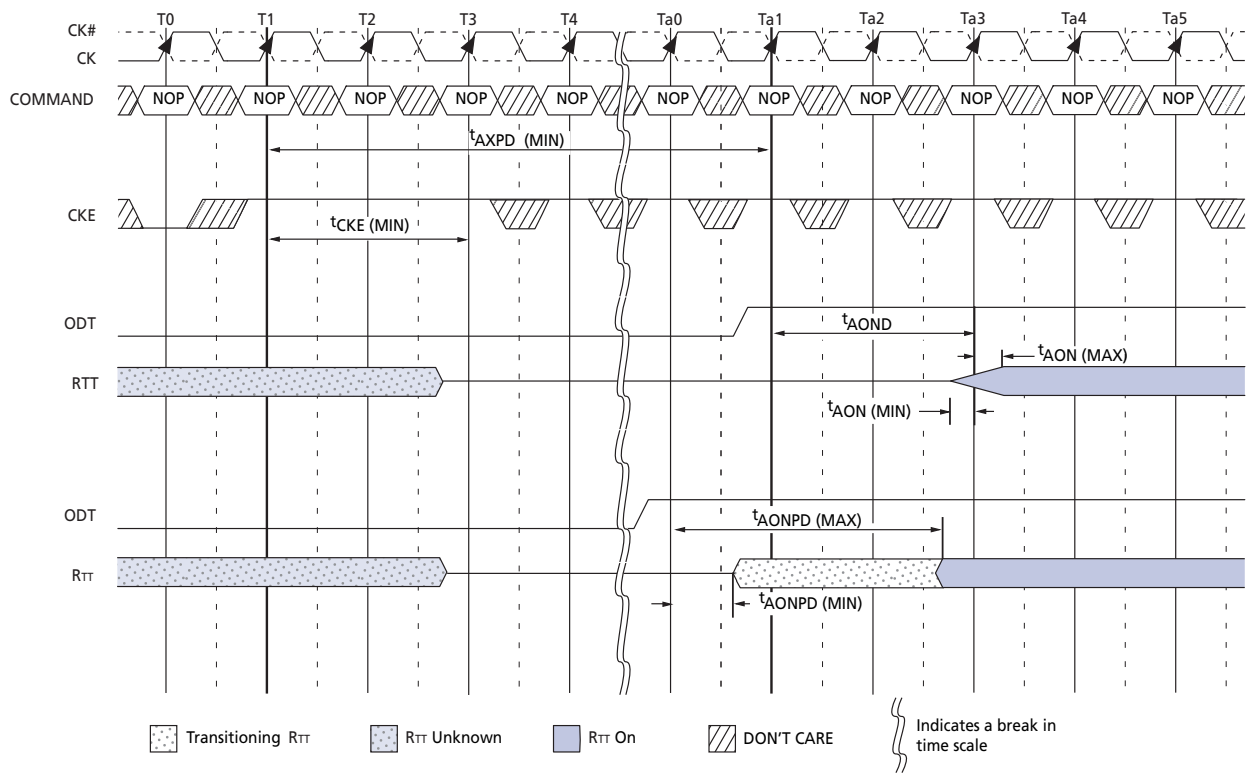

Table 17: DDR2-400/533 ODT Turn-off Timing When Exiting Power-Down Mode

| Parameter | Symbol | Min | Max | Units |
|--------------------------------|-------------|------------------------|--|----------|
| ODT turn-off delay | t_{AOFD} | 2.5 | 2.5 | t_{CK} |
| ODT turn-off | t_{AOF} | $t_{AC} (MIN)$ | $t_{AC} (MAX) + 600$ | ps |
| ODT turn-off (power-down mode) | t_{AOFDP} | $t_{AC} (MIN) + 2,000$ | $2.5 \times t_{CK} + t_{AC} (MAX) + 1,000$ | ps |
| ODT to power-down exit latency | t_{AXPD} | 8 | | t_{CK} |

Note: The half-clock of t_{AOFD} 's 2.5 t_{CK} assumes a 50/50 clock duty cycle. This half-clock value must be derated by the amount of half-clock duty cycle error. For example, if the clock duty cycle was 47/53, t_{AOFD} would actually be 2.5 - 0.03, or 2.47, for $t_{AOF} (MIN)$ and 2.5 + 0.03, or 2.53, for $t_{AOF} (MAX)$.

Figure 67: ODT Turn-on Timing When Exiting Power-Down Mode

Table 18: DDR2-400/533 ODT Turn-On Timing When Exiting Power-Down Mode

| Parameter | Symbol | Min | Max | Units |
|--------------------------------|-------------|------------------------|--|----------|
| ODT turn-on delay | t_{AOND} | 2 | 2 | t_{CK} |
| ODT turn-on | t_{AON} | $t_{AC} (MIN)$ | $t_{AC} (MAX) + 1,000$ | ps |
| ODT turn-on (power-down mode) | t_{AONPD} | $t_{AC} (MIN) + 2,000$ | $2 \times t_{CK} + t_{AC} (MAX) + 1,000$ | ps |
| ODT to power-down exit latency | t_{AXPD} | 8 | | t_{CK} |

Absolute Maximum Ratings

Stresses greater than those listed may cause permanent damage to the device. This is a stress rating only, and functional operation of the device at these or any other conditions above those indicated in the operational sections of this specification is not implied. Exposure to absolute maximum rating conditions for extended periods may affect reliability.

Table 17: Absolute Maximum DC Ratings

| Parameter | Symbol | Min | Max | Units | Notes |
|--|------------|------|-----|---------|-------|
| VDD supply voltage relative to VSS | VDD | -1.0 | 2.3 | V | 1 |
| VDDQ supply voltage relative to VSSQ | VDDQ | -0.5 | 2.3 | V | 1, 2 |
| VDDL supply voltage relative to VSSL | VDDL | -0.5 | 2.3 | V | 1 |
| Voltage on any ball relative to VSS | VIN, VOUT | -0.5 | 2.3 | V | 3 |
| Input leakage current; any input $0V \leq V_{IN} \leq V_{DD}$; all other balls not under test = 0V) | I_I | -5 | 5 | μA | |
| Output leakage current; $0V \leq V_{OUT} \leq V_{DDQ}$; DQ and ODT disabled | I_{OZ} | -5 | 5 | μA | |
| VREF leakage current; VREF = Valid VREF level | I_{VREF} | -2 | 2 | μA | |

- Notes:
1. VDD, VDDQ, and VDDL must be within 300mV of each other at all times.
 2. $V_{REF} \leq 0.6 \times V_{DDQ}$; however, V_{REF} may be $\geq V_{DDQ}$ provided that $V_{REF} \leq 300mV$.
 3. Voltage on any I/O may not exceed voltage on VDDQ.

Temperature and Thermal Impedance

It is imperative that the DDR2 SDRAM device's temperature specifications, shown in Table 18 on page 88, be maintained in order to ensure the junction temperature is in the proper operating range to meet data sheet specifications. An important step in maintaining the proper junction temperature is using the device's thermal impedances correctly. The thermal impedances are listed in Table 19 on page 88 for the applicable and available die revision and packages.

Incorrectly using thermal impedances can produce significant errors. Read Micron technical note TN-00-08, "Thermal Applications," prior to using the thermal impedances listed below. For designs that are expected to last several years and require the flexibility to use several designs, consider using final target theta values, rather than existing values, to account for larger thermal impedances.

The DDR2 SDRAM device's safe junction temperature range can be maintained when the T_{CASE} (T_C) specification is not exceeded. In applications where the device's ambient temperature is too high, use of forced air and/or heat sinks may be required in order to satisfy the case temperature specifications.

Table 18: Temperature Limits

| Parameter | Symbol | Min | Max | Units | Notes |
|------------------------------------|-----------|-----|-----|-------|---------|
| Storage temperature | T_{STG} | -55 | 100 | °C | 1 |
| Operating temperature – commercial | T_C | 0 | 85 | °C | 2, 3 |
| Operating temperature – industrial | T_C | -40 | 95 | °C | 2, 3, 4 |
| | T_{AMB} | -40 | 85 | °C | 4, 5 |

- Notes:
1. MAX storage case temperature; T_{STG} is measured in the center of the package, as shown in Figure 68. This case temperature limit is allowed to be exceeded briefly during package reflow, as noted in Micron technical note TN-00-15, "Recommended Soldering Parameters."
 2. MAX operating case temperature; T_C is measured in the center of the package, as shown in Figure 68.
 3. Device functionality is not guaranteed if the device exceeds maximum T_C during operation.
 4. Both temperature specifications must be satisfied.
 5. Operating ambient temperature surrounding the package.

Table 19: Thermal Impedance

| Die Rev | Package | Substrate | θ_{JA} (°C/W) Airflow = 0m/s | θ_{JA} (°C/W) Airflow = 1m/s | θ_{JA} (°C/W) Airflow = 2m/s | θ_{JB} (°C/W) | θ_{JC} (°C/W) |
|---------------------------------|---------|-----------|---|---|---|----------------------|----------------------|
| A ¹ | 92-ball | 2-layer | 38.3 | 25.3 | 21.3 | 11.8 | 1.7 |
| | | 4-layer | 24.7 | 18.1 | 16.0 | 10.8 | |
| D ¹ | 68-ball | 2-layer | 46.6 | 33.5 | 28.7 | 18.3 | 2.5 |
| | | 4-layer | 32.8 | 26.1 | 23.3 | 18.0 | |
| | 84-ball | 2-layer | 46.6 | 33.5 | 28.7 | 18.3 | 2.5 |
| | | 4-layer | 32.8 | 26.1 | 23.3 | 18.0 | |
| Last shrink target ² | 68-ball | 2-layer | 60.0 | 48.0 | 45.0 | 22.0 | 6.0 |
| | | 4-layer | 39.0 | 34.0 | 32.0 | 22.0 | |
| | 84-ball | 2-layer | 55.0 | 42.0 | 37.0 | 22.0 | 6.0 |
| | | 4-layer | 38.0 | 32.0 | 30.0 | 21.0 | |

- Notes:
1. Thermal resistance data is based on a number of samples from multiple lots and should be viewed as a typical number.
 2. This is an estimate; simulated number and actual results could vary.

Figure 68: Example Temperature Test Point Location

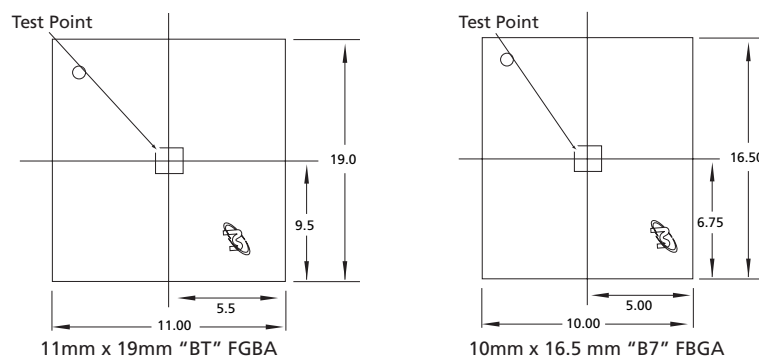

AC and DC Operating Conditions

Table 20: Recommended DC Operating Conditions (SSTL_18)

All voltages referenced to Vss

| Parameter | Symbol | Min | Nom | Max | Units | Notes |
|----------------------------------|----------|---------------|-------------|---------------|-------|-------|
| Supply voltage | VDD | 1.7 | 1.8 | 1.9 | V | 1, 5 |
| VDDL supply voltage | VDDL | 1.7 | 1.8 | 1.9 | V | 4, 5 |
| I/O supply voltage | VDDQ | 1.7 | 1.8 | 1.9 | V | 4, 5 |
| I/O reference voltage | VREF(DC) | 0.49 x VDDQ | 0.50 x VDDQ | 0.51 x VDDQ | V | 2 |
| I/O termination voltage (system) | VTT | VREF(DC) - 40 | VREF(DC) | VREF(DC) + 40 | mV | 3 |

- Notes:
1. VDD and VDDQ must track each other. VDDQ must be \leq VDD.
 2. VREF is expected to equal VDDQ/2 of the transmitting device and to track variations in the DC level of the same. Peak-to-peak noise (non-common mode) on VREF may not exceed ± 1 percent of the DC value. Peak-to-peak AC noise on VREF may not exceed ± 2 percent of VREF(DC). This measurement is to be taken at the nearest VREF bypass capacitor.
 3. VTT is not applied directly to the device. VTT is a system supply for signal termination resistors, is expected to be set equal to VREF, and must track variations in the DC level of VREF.
 4. VDDQ tracks with VDD; VDDL tracks with VDD.
 5. VSSQ = VSSL = VSS.

Table 21: ODT DC Electrical Characteristics

All voltages referenced to Vss

| Parameter | Symbol | Min | Nom | Max | Units | Notes |
|---|------------------------|-----|-----|-----|-------|-------|
| R _{TT} effective impedance value for 75Ω setting EMR (A6, A2) = 0, 1 | R _{TT1} (EFF) | 60 | 75 | 90 | Ω | 1, 3 |
| R _{TT} effective impedance value for 150Ω setting EMR (A6, A2) = 1, 0 | R _{TT2} (EFF) | 120 | 150 | 180 | Ω | 1, 3 |
| R _{TT} effective impedance value for 50Ω setting EMR (A6, A2) = 1, 1 | R _{TT3} (EFF) | 40 | 50 | 60 | Ω | 1, 3 |
| Deviation of VM with respect to VDDQ/2 | ΔVM | -6 | | 6 | % | 2 |

- Notes:
1. R_{TT1}(EFF) and R_{TT2}(EFF) are determined by separately applying V_{IH}(AC) and V_{IL}(AC) to the ball being tested, and then measuring current, I(V_{IH}(AC)), and I(V_{IL}(AC)), respectively.

$$R_{TT}(\text{EFF}) = \frac{V_{IH}(\text{AC}) - V_{IL}(\text{AC})}{I(V_{IH}(\text{AC})) - I(V_{IL}(\text{AC}))}$$

2. Measure voltage (VM) at tested ball with no load.

$$\Delta VM = \left(\frac{2 \times VM}{V_{DDQ}} - 1 \right) \times 100$$

3. IT device minimum values are derated by six percent when device operates between -40°C and 0°C (T_C).

Input Electrical Characteristics and Operating Conditions

Table 22: Input DC Logic Levels
 All voltages referenced to V_{SS}

| Parameter | Symbol | Min | Max | Units |
|------------------------------|---------------------|----------------------------|----------------------------|-------|
| Input HIGH (logic 1) voltage | V _{IH(DC)} | V _{REF(DC)} + 125 | V _{DDQ} + 300 | mV |
| Input LOW (logic 0) voltage | V _{IL(DC)} | -300 | V _{REF(DC)} - 125 | mV |

Table 23: Input AC Logic Levels
 All voltages referenced to V_{SS}

| Parameter | Symbol | Min | Max | Units |
|--|---------------------|----------------------------|----------------------------|-------|
| Input HIGH (logic 1) voltage (-5E/-37E) | V _{IH(AC)} | V _{REF(DC)} + 250 | - | mV |
| Input HIGH (logic 1) voltage (-3/-3E/-25/-25E) | V _{IH(AC)} | V _{REF(DC)} + 200 | - | mV |
| Input LOW (logic 0) voltage (-5E/-37E) | V _{IL(AC)} | - | V _{REF(DC)} - 250 | mV |
| Input LOW (logic 0) voltage (-3/-3E/-25/-25E) | V _{IL(AC)} | - | V _{REF(DC)} - 200 | mV |

Figure 69: Single-Ended Input Signal Levels

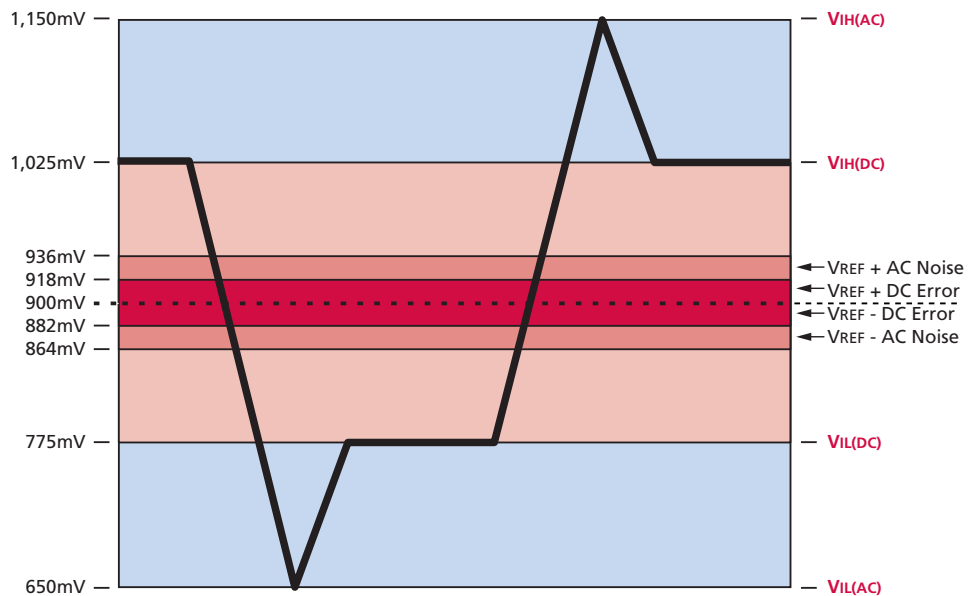

Note: Numbers in diagram reflect nominal values.

Table 24: Differential Input Logic Levels

All voltages referenced to V_{SS}

| Parameter | Symbol | Min | Max | Units | Notes |
|-------------------------------------|---------------------|-------------------------------|-------------------------------|-------|-------|
| DC input signal voltage | V _{IN(DC)} | -300 | V _{DDQ} + 300 | mV | 1 |
| DC differential input voltage | V _{ID(DC)} | 250 | V _{DDQ} + 600 | mV | 2 |
| AC differential input voltage | V _{ID(AC)} | 500 | V _{DDQ} + 600 | mV | 3 |
| AC differential cross-point voltage | V _{IX(AC)} | 0.50 x V _{DDQ} - 175 | 0.50 x V _{DDQ} + 175 | mV | 4 |
| Input midpoint voltage | V _{MP(DC)} | 850 | 950 | mV | 5 |

- Notes:
- V_{IN(DC)} specifies the allowable DC execution of each input of differential pair such as CK, CK#, DQS, DQS#, LDQS, LDQS#, UDQS, UDQS#, and RDQS, RDQS#.
 - V_{ID(DC)} specifies the input differential voltage |V_{TR} - V_C| required for switching, where V_{TR} is the true input (such as CK, DQS, LDQS, UDQS) level and V_C is the complementary input (such as CK#, DQS#, LDQS#, UDQS#). The minimum value is equal to V_{IH(DC)} - V_{IL(DC)}. Differential input signal levels are shown in Figure 70.
 - V_{ID(AC)} specifies the input differential voltage |V_{TR} - V_C| required for switching, where V_{TR} is the true input (such as CK, DQS, LDQS, UDQS, RDQS) level and V_C is the complementary input (such as CK#, DQS#, LDQS#, UDQS#, RDQS#). The minimum value is equal to V_{IH(AC)} - V_{IL(AC)}, as shown in Table 23 on page 90.
 - The typical value of V_{IX(AC)} is expected to be about 0.5 x V_{DDQ} of the transmitting device and V_{IX(AC)} is expected to track variations in V_{DDQ}. V_{IX(AC)} indicates the voltage at which differential input signals must cross, as shown in Figure 70.
 - V_{MP(DC)} specifies the input differential common mode voltage (V_{TR} + V_C)/2 where V_{TR} is the true input (CK, DQS) level and V_C is the complementary input (CK#, DQS#). V_{MP(DC)} is expected to be approximately 0.5 x V_{DDQ}.

Figure 70: Differential Input Signal Levels

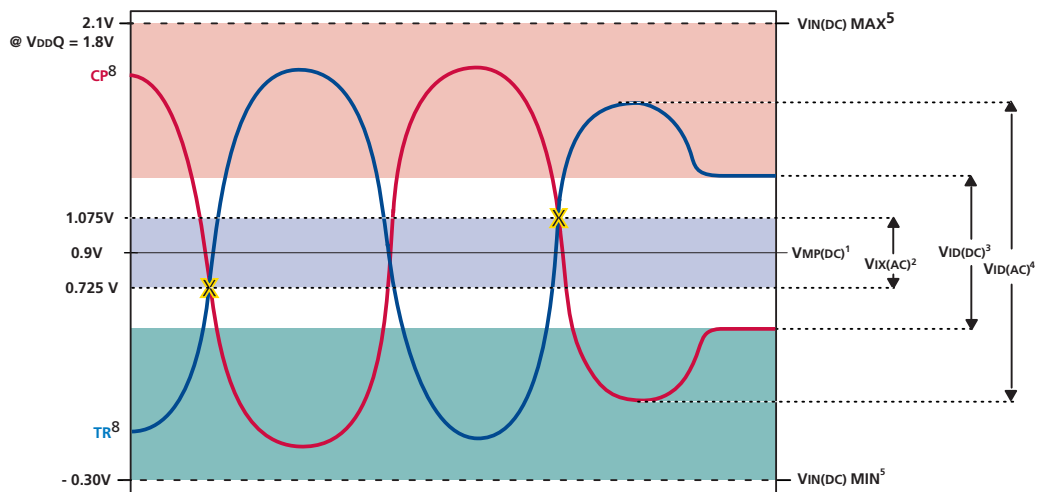

- Notes:
- This provides a minimum of 850mV to a maximum of 950mV and is expected to be V_{DDQ}/2.
 - TR and CP must cross in this region.
 - TR and CP must meet at least V_{ID(DC)} MIN when static and is centered around V_{MP(DC)}.
 - TR and CP must have a minimum 500mV peak-to-peak swing.
 - TR and CP may not be more positive than V_{DDQ} + 0.3V or more negative than V_{SS} - 0.3V.
 - For AC operation, all DC clock requirements must also be satisfied.
 - Numbers in diagram reflect nominal values (V_{DDQ} = 1.8V).
 - TR represents the CK, DQS, RDQS, LDQS, and UDQS signals; CP represents CK#, DQS#, RDQS#, LDQS#, and UDQS# signals.

Table 25: AC Input Test Conditions

| Parameter | Symbol | Min | Max | Units | Notes |
|--|----------|----------------------|-------------|-------|---------------|
| Input setup timing measurement reference level BA2–BA0, A0–A12 A0–A13 (A12 x16) A0–A13 A0–A14, CS#, RAS#, CAS#, WE#, ODT, DM, UDM, LDM, and CKE | VRS | See Note 2 | | | 1, 2, 7, 8 |
| Input hold timing measurement reference level BA2–BA0, A0–A12 A0–A13 (A12 x16) A0–A13 A0–A14, CS#, RAS#, CAS#, WE#, ODT, DM, UDM, LDM, and CKE | VRH | See Note 3 | | | 1, 3, 7, 8 |
| Input timing measurement reference level (single-ended) DQS for x4, x8; UDQS, LDQS for x16 | VREF(DC) | VDDQ x 0.49 | VDDQ x 0.51 | V | 1, 4, 7, 8 |
| Input timing measurement reference level (differential) CK, CK# for x4, x8, x16 DQS, DQS# for x4, x8; RDQS, RDQS# for x8 UDQS, UDQS#, LDQS, LDQS# for x16 | VRD | V _{Ix} (AC) | | V | 1, 5, 6, 7, 9 |

- Notes:
1. All voltages referenced to V_{ss}.
 2. Input waveform setup timing (t_{ISb}) is referenced from the input signal crossing at the V_{IH}(AC) level for a rising signal and V_{IL}(AC) for a falling signal applied to the device under test, as shown in Figure 79 on page 107.
 3. Input waveform hold (t_{IHb}) timing is referenced from the input signal crossing at the V_{IL}(DC) level for a rising signal and V_{IH}(DC) for a falling signal applied to the device under test, as shown in Figure 79 on page 107.
 4. Input waveform setup timing (t_{DS}) and hold timing (t_{DH}) for single-ended data strobe is referenced from the crossing of DQS, UDQS, or LDQS through the VREF level applied to the device under test, as shown in Figure 81 on page 108.
 5. Input waveform setup timing (t_{DS}) and hold timing (t_{DH}) when differential data strobe is enabled is referenced from the cross-point of DQS/DQS#, UDQS/UDQS#, or LDQS/LDQS#, as shown in Figure 80 on page 107.
 6. Input waveform timing is referenced to the crossing point level (V_{Ix}) of two input signals (V_{TR} and V_{CP}) applied to the device under test, where V_{TR} is the “true” input signal and V_{CP} is the complementary input signal, as shown in Figure 82 on page 108.
 7. See “Input Slew Rate Derating” on page 93.
 8. The slew rate for single-ended inputs is measured from DC-level to AC-level, (V_{IL}(DC) to V_{IH}(AC) on the rising edge and V_{IL}(AC) to V_{IH}(DC) on the falling edge. For signals referenced to VREF, the valid intersection is where the “tangent” line intersects VREF, as shown in Figures 72, 74, 76, and 78.
 9. The slew rate for differentially ended inputs is measured from twice the DC-level to twice the AC-level: 2 x V_{IL}(DC) to 2 x V_{IH}(AC) on the rising edge and 2 x V_{IL}(AC) to 2 x V_{IH}(DC) on the falling edge). For example, the CK/CK# would be –250mV to +500mV for CK rising edge and would be +250mV to –500mV for CK falling edge.

Input Slew Rate Derating

For all input signals, the total t_{IS} (setup time) and t_{IH} (hold time) required is calculated by adding the data sheet t_{IS} (base) and t_{IH} (base) value to the Δt_{IS} and Δt_{IH} derating value, respectively. Example: t_{IS} (total setup time) = t_{IS} (base) + Δt_{IS} .

t_{IS} , the nominal slew rate for a rising signal, is defined as the slew rate between the last crossing of $V_{REF(DC)}$ and the first crossing of $V_{IH(AC)}$ MIN. Setup nominal slew rate (t_{IS}) for a falling signal is defined as the slew rate between the last crossing of $V_{REF(DC)}$ and the first crossing of $V_{IL(AC)}$ MAX.

If the actual signal is always earlier than the nominal slew rate line between shaded “ $V_{REF(DC)}$ to AC region,” use nominal slew rate for derating value (Figure 71 on page 95).

If the actual signal is later than the nominal slew rate line anywhere between shaded “ $V_{REF(DC)}$ to AC region,” the slew rate of a tangent line to the actual signal from the AC level to DC level is used for derating value (see Figure 72 on page 96).

t_{IH} , the nominal slew rate for a rising signal, is defined as the slew rate between the last crossing of $V_{IL(DC)}$ MAX and the first crossing of $V_{REF(DC)}$. t_{IH} , nominal slew rate for a falling signal, is defined as the slew rate between the last crossing of $V_{IH(DC)}$ MIN and the first crossing of $V_{REF(DC)}$.

If the actual signal is always later than the nominal slew rate line between shaded “DC to $V_{REF(DC)}$ region,” use nominal slew rate for derating value (Figure 73 on page 97).

If the actual signal is earlier than the nominal slew rate line anywhere between shaded “DC to $V_{REF(DC)}$ region,” the slew rate of a tangent line to the actual signal from the DC level to $V_{REF(DC)}$ level is used for the derating value (Figure 74 on page 98).

Although the total setup time might be negative for slow slew rates (a valid input signal will not have reached $V_{IH(AC)}/V_{IL(AC)}$ at the time of the rising clock transition), a valid input signal is still required to complete the transition and reach $V_{IH(AC)}/V_{IL(AC)}$.

For slew rates in between the values listed in Tables 26 and 27, the derating values may be obtained by linear interpolation.

Table 26: DDR2-400/533 Setup and Hold Time Derating Values (t_{IS} and t_{IH})

| Command/ Address Slew Rate (V/ns) | CK, CK# Differential Slew Rate | | | | | | Units |
|---|--------------------------------|-----------------|-----------------|-----------------|-----------------|-----------------|-------|
| | 2.0 V/ns | | 1.5 V/ns | | 1.0 V/ns | | |
| | Δt_{IS} | Δt_{IH} | Δt_{IS} | Δt_{IH} | Δt_{IS} | Δt_{IH} | |
| 4.0 | +187 | +94 | +217 | +124 | +247 | +154 | ps |
| 3.5 | +179 | +89 | +209 | +119 | +239 | +149 | ps |
| 3.0 | +167 | +83 | +197 | +113 | +227 | +143 | ps |
| 2.5 | +150 | +75 | +180 | +105 | +210 | +135 | ps |
| 2.0 | +125 | +45 | +155 | +75 | +185 | +105 | ps |
| 1.5 | +83 | +21 | +113 | +51 | +143 | +81 | ps |
| 1.0 | 0 | 0 | +30 | +30 | +60 | +60 | ps |
| 0.9 | -11 | -14 | +19 | +16 | +49 | +46 | ps |
| 0.8 | -25 | -31 | +5 | -1 | +35 | +29 | ps |
| 0.7 | -43 | -54 | -13 | -24 | +17 | +6 | ps |
| 0.6 | -67 | -83 | -37 | -53 | -7 | -23 | ps |
| 0.5 | -110 | -125 | -80 | -95 | -50 | -65 | ps |
| 0.4 | -175 | -188 | -145 | -158 | -115 | -128 | ps |
| 0.3 | -285 | -292 | -255 | -262 | -225 | -232 | ps |
| 0.25 | -350 | -375 | -320 | -345 | -290 | -315 | ps |
| 0.2 | -525 | -500 | -495 | -470 | -465 | -440 | ps |
| 0.15 | -800 | -708 | -770 | -678 | -740 | -648 | ps |
| 0.1 | -1,450 | -1,125 | -1,420 | -1,095 | -1,390 | -1,065 | ps |

Table 27: DDR2-667 Setup and Hold Time Derating Values (t_{IS} and t_{IH})

| Command/ Address Slew Rate (V/ns) | CK, CK# Differential Slew Rate | | | | | | Units |
|---|--------------------------------|-----------------|-----------------|-----------------|-----------------|-----------------|-------|
| | 2.0 V/ns | | 1.5 V/ns | | 1.0 V/ns | | |
| | Δt_{IS} | Δt_{IH} | Δt_{IS} | Δt_{IH} | Δt_{IS} | Δt_{IH} | |
| 4.0 | +150 | +94 | +180 | +124 | +210 | +154 | ps |
| 3.5 | +143 | +89 | +173 | +119 | +203 | +149 | ps |
| 3.0 | +133 | +83 | +163 | +113 | +193 | +143 | ps |
| 2.5 | +120 | +75 | +150 | +105 | +180 | +135 | ps |
| 2.0 | +100 | +45 | +160 | +75 | +160 | +105 | ps |
| 1.5 | +67 | +21 | +97 | +51 | +127 | +81 | ps |
| 1.0 | 0 | 0 | +30 | +30 | +60 | +60 | ps |
| 0.9 | -5 | -14 | +25 | +16 | +55 | +46 | ps |
| 0.8 | -13 | -31 | +17 | -1 | +47 | +29 | ps |
| 0.7 | -22 | -54 | +8 | -24 | +38 | +6 | ps |
| 0.6 | -34 | -83 | -4 | -53 | +36 | -23 | ps |
| 0.5 | -60 | -125 | -30 | -95 | 0 | -65 | ps |
| 0.4 | -100 | -188 | -70 | -158 | -40 | -128 | ps |
| 0.3 | -168 | -292 | -138 | -262 | -108 | -232 | ps |
| 0.25 | -200 | -375 | -170 | -345 | -140 | -315 | ps |
| 0.2 | -325 | -500 | -295 | -470 | -265 | -440 | ps |
| 0.15 | -517 | -708 | -487 | -678 | -457 | -648 | ps |
| 0.1 | -1,000 | -1,125 | -970 | -1,095 | -940 | -1,065 | ps |

Figure 71: Nominal Slew Rate for t_{IS}

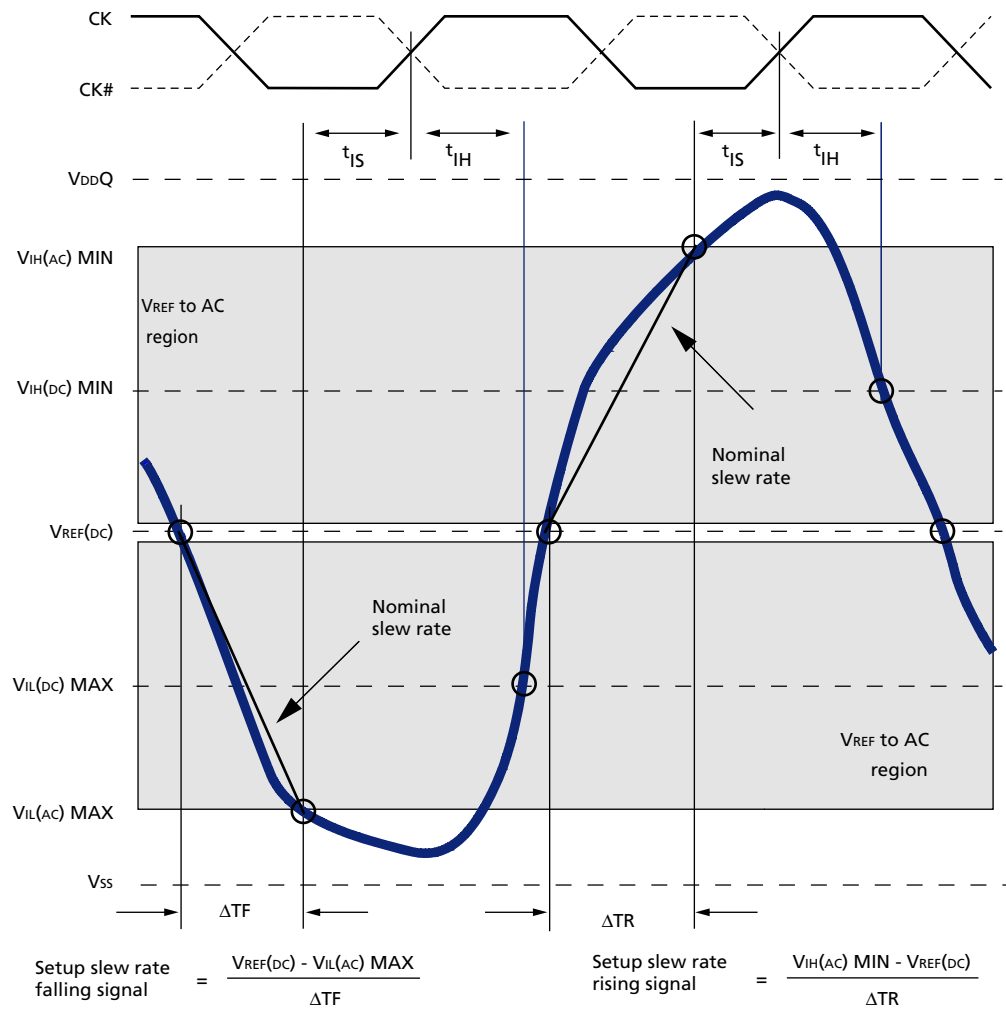

Figure 72: Tangent Line for t_{IS}

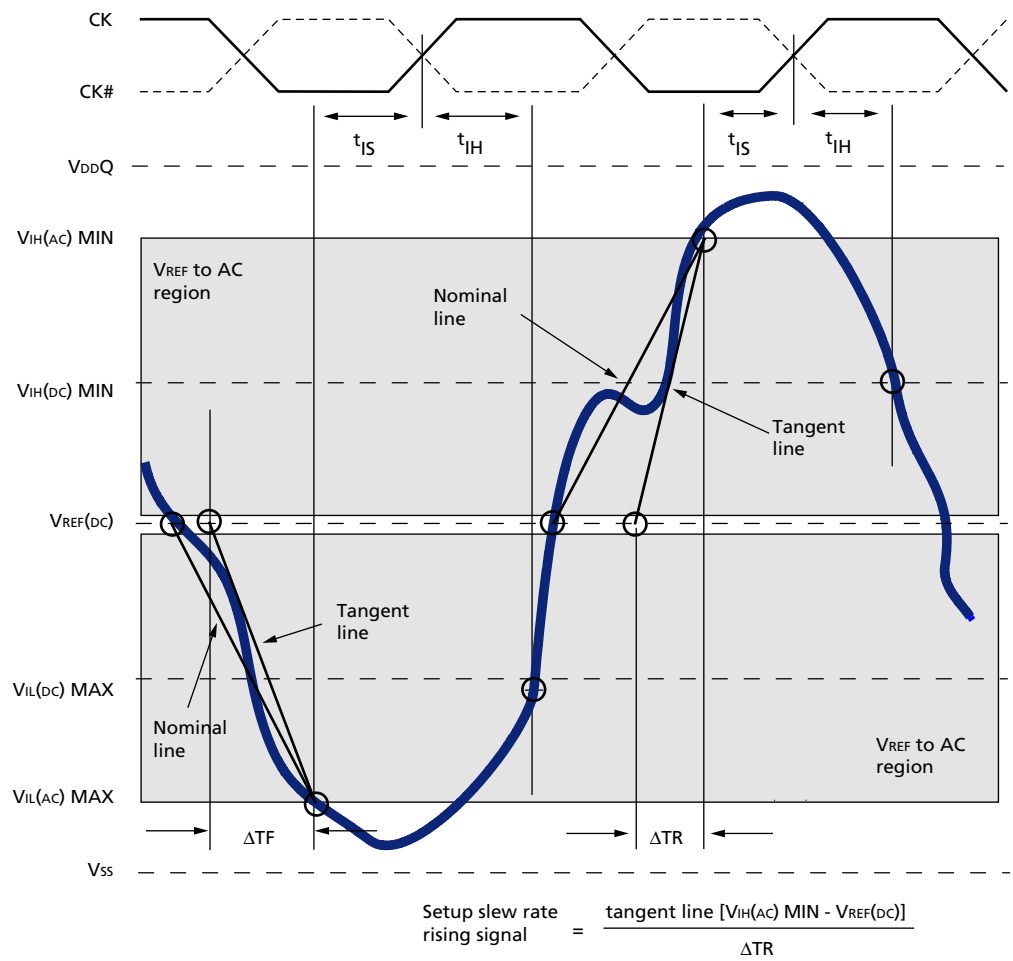

Figure 73: Nominal Slew Rate for t_{IH}

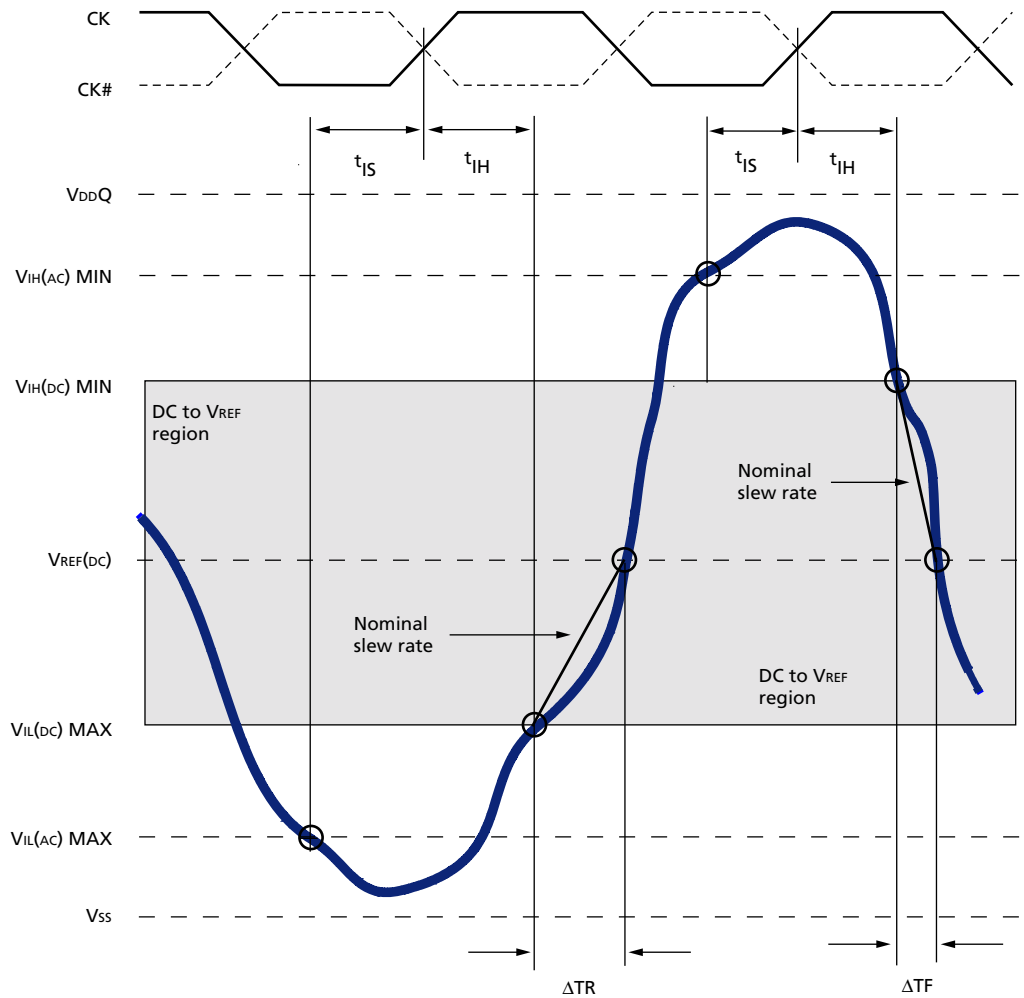

Figure 74: Tangent Line for t_{IH}

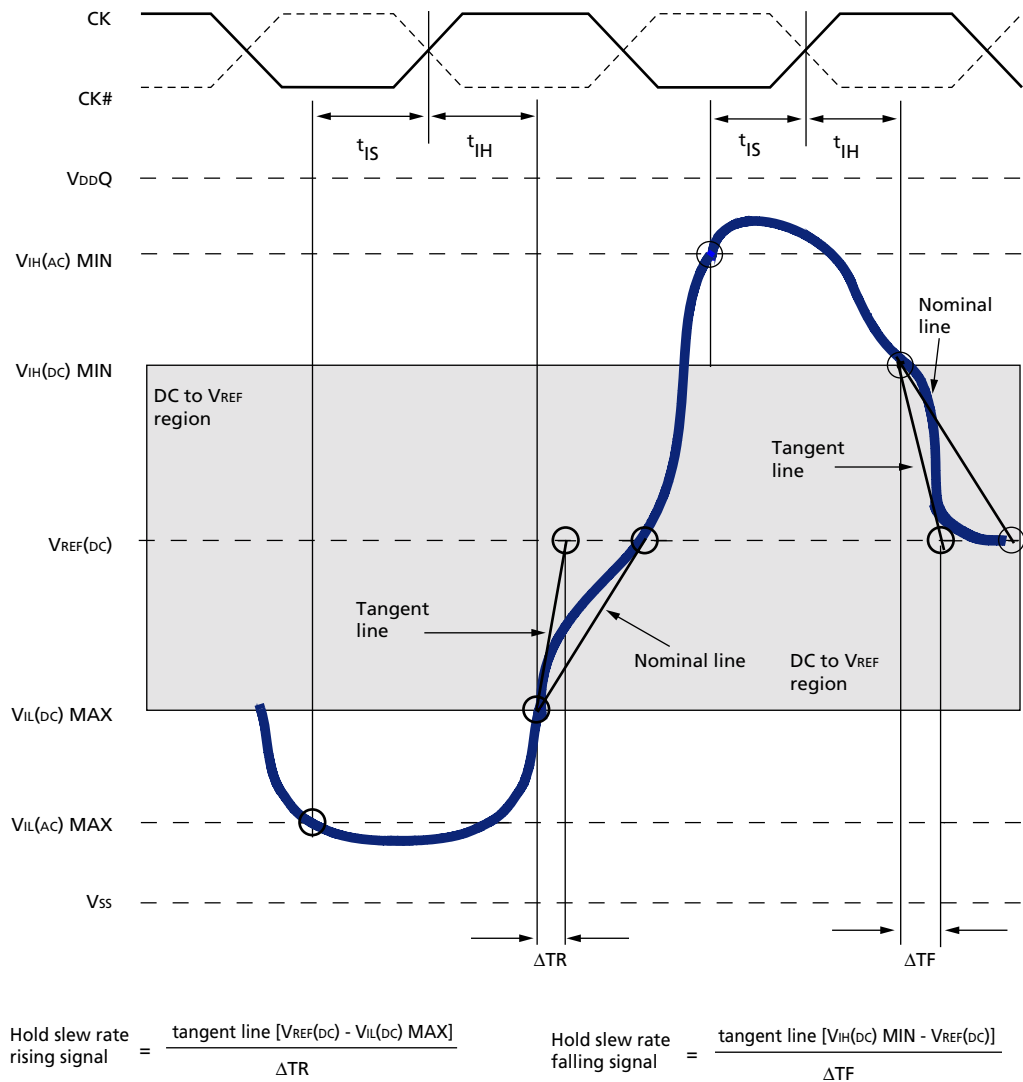

Table 28: DDR2-400/533 t_{DS} , t_{DH} Derating Values with Differential Strobe

Notes: 1–7; all units in ps

| DQ Slew Rate (V/ns) | DQS, DQS# Differential Slew Rate | | | | | | | | | | | | | | | | | |
|---------------------|----------------------------------|-----------------|-----------------|-----------------|-----------------|-----------------|-----------------|-----------------|-----------------|-----------------|-----------------|-----------------|-----------------|-----------------|-----------------|-----------------|-----------------|-----------------|
| | 4.0 V/ns | | 3.0 V/ns | | 2.0 V/ns | | 1.8 V/ns | | 1.6 V/ns | | 1.4 V/ns | | 1.2 V/ns | | 1.0 V/ns | | 0.8 V/ns | |
| | Δt_{DS} | Δt_{DH} | Δt_{DS} | Δt_{DH} | Δt_{DS} | Δt_{DH} | Δt_{DS} | Δt_{DH} | Δt_{DS} | Δt_{DH} | Δt_{DS} | Δt_{DH} | Δt_{DS} | Δt_{DH} | Δt_{DS} | Δt_{DH} | Δt_{DS} | Δt_{DH} |
| 2.0 | 125 | 45 | 125 | 45 | 125 | 45 | – | – | – | – | – | – | – | – | – | – | – | – |
| 1.5 | 83 | 21 | 83 | 21 | 83 | 21 | 95 | 33 | – | – | – | – | – | – | – | – | – | – |
| 1.0 | 0 | 0 | 0 | 0 | 0 | 0 | 12 | 12 | 24 | 24 | – | – | – | – | – | – | – | – |
| 0.9 | – | – | –11 | –14 | –11 | –14 | 1 | –2 | 13 | 10 | 25 | 22 | – | – | – | – | – | – |
| 0.8 | – | – | – | – | –25 | –31 | –13 | –19 | –1 | –7 | 11 | 5 | 23 | 17 | – | – | – | – |
| 0.7 | – | – | – | – | – | – | –31 | –42 | –19 | –30 | –7 | –18 | 5 | –6 | 17 | 6 | – | – |
| 0.6 | – | – | – | – | – | – | – | – | –43 | –59 | –31 | –47 | –19 | –35 | –7 | –23 | 5 | –11 |
| 0.5 | – | – | – | – | – | – | – | – | – | – | –74 | –89 | –62 | –77 | –50 | –65 | –38 | –53 |
| 0.4 | – | – | – | – | – | – | – | – | – | – | – | – | –127 | –140 | –115 | –128 | –103 | –116 |

- Notes:
- For all input signals, the total t_{DS} and t_{DH} required is calculated by adding the data sheet value to the derating value listed in Table 28.
 - t_{DS} nominal slew rate for a rising signal is defined as the slew rate between the last crossing of $V_{REF}(DC)$ and the first crossing of $V_{IH}(AC)$ MIN. t_{DS} nominal slew rate for a falling signal is defined as the slew rate between the last crossing of $V_{REF}(DC)$ and the first crossing of $V_{IL}(AC)$ MAX. If the actual signal is always earlier than the nominal slew rate line between shaded “ $V_{REF}(DC)$ to AC region,” use nominal slew rate for derating value (see Figure 75). If the actual signal is later than the nominal slew rate line anywhere between shaded “ $V_{REF}(DC)$ to AC region,” the slew rate of a tangent line to the actual signal from the AC level to DC level is used for derating value (see Figure 76).
 - t_{DH} nominal slew rate for a rising signal is defined as the slew rate between the last crossing of $V_{IL}(DC)$ MAX and the first crossing of $V_{REF}(DC)$. t_{DH} nominal slew rate for a falling signal is defined as the slew rate between the last crossing of $V_{IH}(DC)$ MIN and the first crossing of $V_{REF}(DC)$. If the actual signal is always later than the nominal slew rate line between shaded “DC level to $V_{REF}(DC)$ region,” use nominal slew rate for derating value (see Figure 77). If the actual signal is earlier than the nominal slew rate line anywhere between shaded “DC to $V_{REF}(DC)$ region,” the slew rate of a tangent line to the actual signal from the DC level to $V_{REF}(DC)$ level is used for derating value (see Figure 78).
 - Although the total setup time might be negative for slow slew rates (a valid input signal will not have reached $V_{IH}(AC)/V_{IL}(AC)$ at the time of the rising clock transition), a valid input signal is still required to complete the transition and reach $V_{IH}(AC)/V_{IL}(AC)$.
 - For slew rates between the values listed in this table, the derating values may be obtained by linear interpolation.
 - These values are typically not subject to production test. They are verified by design and characterization.
 - Single-ended DQS requires special derating. The values in Table 30 are the DQS single-ended slew rate derating with DQS referenced at V_{REF} and DQ referenced at the logic levels t_{DS_b} and t_{DH_b} . Table 31 provides the V_{REF} -based fully derated values for the DQ (t_{DS_a} and t_{DH_a}) for DDR2-667. Table 32 provides the V_{REF} -based fully derated values for the DQ (t_{DS_a} and t_{DH_a}) for DDR2-533. Table 33 provides the V_{REF} -based fully derated values for the DQ (t_{DS_a} and t_{DH_a}) for DDR2-400.

Table 29: DDR2-667 t_{DS} , t_{DH} Derating Values with Differential Strobe

Notes: 1–7; all units in ps

| DQ Slew Rate (V/ns) | DQS, DQS# Differential Slew Rate | | | | | | | | | | | | | | | | | |
|---------------------|----------------------------------|-----------------|-----------------|-----------------|-----------------|-----------------|-----------------|-----------------|-----------------|-----------------|-----------------|-----------------|-----------------|-----------------|-----------------|-----------------|-----------------|-----------------|
| | 2.8 V/ns | | 2.4 V/ns | | 2.0 V/ns | | 1.8 V/ns | | 1.6 V/ns | | 1.4 V/ns | | 1.2 V/ns | | 1.0 V/ns | | 0.8 V/ns | |
| | Δt_{DS} | Δt_{DH} | Δt_{DS} | Δt_{DH} | Δt_{DS} | Δt_{DH} | Δt_{DS} | Δt_{DH} | Δt_{DS} | Δt_{DH} | Δt_{DS} | Δt_{DH} | Δt_{DS} | Δt_{DH} | Δt_{DS} | Δt_{DH} | Δt_{DS} | Δt_{DH} |
| 2.0 | 100 | 63 | 100 | 63 | 100 | 63 | 112 | 75 | 124 | 87 | 136 | 99 | 148 | 111 | 160 | 123 | 172 | 135 |
| 1.5 | 67 | 42 | 67 | 42 | 67 | 42 | 79 | 54 | 91 | 66 | 103 | 78 | 115 | 90 | 127 | 102 | 139 | 114 |
| 1.0 | 0 | 0 | 0 | 0 | 0 | 0 | 12 | 12 | 24 | 24 | 36 | 36 | 48 | 48 | 60 | 60 | 72 | 72 |
| 0.9 | -5 | -14 | -5 | -14 | -5 | -14 | 7 | -2 | 19 | 10 | 31 | 22 | 43 | 34 | 55 | 46 | 67 | 58 |
| 0.8 | -13 | -31 | -13 | -31 | -13 | -31 | -1 | -19 | 11 | -7 | 23 | 5 | 35 | 17 | 47 | 29 | 59 | 41 |
| 0.7 | -22 | -54 | -22 | -54 | -22 | -54 | -10 | -42 | 2 | -30 | 14 | -18 | 26 | -6 | 38 | 6 | 50 | 18 |
| 0.6 | -34 | -83 | -34 | -83 | -34 | -83 | -22 | -71 | -10 | -59 | 2 | -47 | 14 | -35 | 26 | -23 | 38 | -11 |
| 0.5 | -60 | -125 | -60 | -125 | -60 | -125 | -48 | -113 | -36 | -101 | -24 | -89 | -12 | -77 | 0 | -65 | 12 | -53 |
| 0.4 | -100 | -188 | -100 | -188 | -100 | -188 | -88 | -176 | -76 | -164 | -64 | -152 | -52 | -140 | -40 | -128 | -28 | -116 |

- Notes:
- For all input signals the total t_{DS} and t_{DH} required is calculated by adding the data sheet value to the derating value listed in Table 29.
 - t_{DS} nominal slew rate for a rising signal is defined as the slew rate between the last crossing of $V_{REF}(DC)$ and the first crossing of $V_{IH}(AC)$ MIN. t_{DS} nominal slew rate for a falling signal is defined as the slew rate between the last crossing of $V_{REF}(DC)$ and the first crossing of $V_{IL}(AC)$ MAX. If the actual signal is always earlier than the nominal slew rate line between shaded "VREF(DC) to AC region," use nominal slew rate for derating value (see Figure 75). If the actual signal is later than the nominal slew rate line anywhere between shaded "VREF(DC) to AC region," the slew rate of a tangent line to the actual signal from the AC level to DC level is used for derating value (see Figure 76).
 - t_{DH} nominal slew rate for a rising signal is defined as the slew rate between the last crossing of $V_{IL}(DC)$ MAX and the first crossing of $V_{REF}(DC)$. t_{DH} nominal slew rate for a falling signal is defined as the slew rate between the last crossing of $V_{IH}(DC)$ MIN and the first crossing of $V_{REF}(DC)$. If the actual signal is always later than the nominal slew rate line between shaded "DC level to VREF(DC) region," use nominal slew rate for derating value (see Figure 77). If the actual signal is earlier than the nominal slew rate line anywhere between shaded "DC to VREF(DC) region," the slew rate of a tangent line to the actual signal from the DC level to $V_{REF}(DC)$ level is used for derating value (see Figure 78).
 - Although the total setup time might be negative for slow slew rates (a valid input signal will not have reached $V_{IH}(AC)/V_{IL}(AC)$ at the time of the rising clock transition), a valid input signal is still required to complete the transition and reach $V_{IH}(AC)/V_{IL}(AC)$.
 - For slew rates between the values listed in this table, the derating values may be obtained by linear interpolation.
 - These values are typically not subject to production test. They are verified by design and characterization.
 - Single-ended DQS requires special derating. The values in Table 30 are the DQS single-ended slew rate derating with DQS referenced at V_{REF} and DQ referenced at the logic levels t_{DS_b} and t_{DH_b} . Table 31 provides the V_{REF} -based fully derated values for the DQ (t_{DS_a} and t_{DH_a}) for DDR2-667. Table 32 provides the V_{REF} -based fully derated values for the DQ (t_{DS_a} and t_{DH_a}) for DDR2-533. Table 33 provides the V_{REF} -based fully derated values for the DQ (t_{DS_a} and t_{DH_a}) for DDR2-400.

Table 30: Single-Ended DQS Slew Rate Derating Values Using t_{DS_b} and t_{DH_b}
Reference points indicated in bold

| DQ (V/ns) | DQS Single-Ended Slew Rate Derated (at VREF) | | | | | | | | | | | | | | | | | |
|--------------|--|----------|----------|----------|----------|----------|----------|----------|----------|----------|-----------|------------|----------|----------|----------|----------|----------|----------|
| | 2.0 V/ns | | 1.8 V/ns | | 1.6 V/ns | | 1.4 V/ns | | 1.2 V/ns | | 1.0 V/ns | | 0.8 V/ns | | 0.6 V/ns | | 0.4V/ns | |
| | t_{DS} | t_{DH} | t_{DS} | t_{DH} | t_{DS} | t_{DH} | t_{DS} | t_{DH} | t_{DS} | t_{DH} | t_{DS} | t_{DH} | t_{DS} | t_{DH} | t_{DS} | t_{DH} | t_{DS} | t_{DH} |
| 2 | 130 | 53 | 130 | 53 | 130 | 53 | 130 | 53 | 130 | 53 | 145 | 48 | 155 | 45 | 165 | 41 | 175 | 38 |
| 1.5 | 97 | 32 | 97 | 32 | 97 | 32 | 97 | 32 | 97 | 32 | 112 | 27 | 122 | 24 | 132 | 20 | 142 | 17 |
| 1 | 30 | -10 | 30 | -10 | 30 | -10 | 30 | -10 | 30 | -10 | 45 | -15 | 55 | -18 | 65 | -22 | 75 | -25 |
| 0.9 | 25 | -24 | 25 | -24 | 25 | -24 | 25 | -24 | 25 | -24 | 40 | -29 | 50 | -32 | 60 | -36 | 70 | -39 |
| 0.8 | 17 | -41 | 17 | -41 | 17 | -41 | 17 | -41 | 17 | -41 | 32 | -46 | 42 | -49 | 52 | -53 | 61 | -56 |
| 0.7 | 5 | -64 | 5 | -64 | 5 | -64 | 5 | -64 | 5 | -64 | 20 | -69 | 30 | -72 | 40 | -75 | 50 | -79 |
| 0.6 | -7 | -93 | -7 | -93 | -7 | -93 | -7 | -93 | -7 | -93 | 8 | -98 | 18 | -102 | 28 | -105 | 38 | -108 |
| 0.5 | -28 | -135 | -28 | -135 | -28 | -135 | -28 | -135 | -28 | -135 | -13 | -140 | -3 | -143 | 7 | -147 | 17 | -150 |
| 0.4 | -78 | -198 | -78 | -198 | -78 | -198 | -78 | -198 | -78 | -198 | -63 | -203 | -53 | -206 | -43 | -210 | -33 | -213 |

 Notes: 1. Derating values, to be used with base t_{DS_b} - and t_{DH_b} -specified values.

Table 31: Single-Ended DQS Slew Rate Fully Derated (DQS, DQ at VREF) at DDR2-667
Reference points indicated in bold

| DQ (V/ns) | DQS Single-Ended Slew Rate Derated (at VREF) | | | | | | | | | | | | | | | | | |
|--------------|--|----------|----------|----------|----------|----------|----------|----------|----------|----------|------------|------------|----------|----------|----------|----------|----------|----------|
| | 2.0 V/ns | | 1.8 V/ns | | 1.6 V/ns | | 1.4 V/ns | | 1.2 V/ns | | 1.0 V/ns | | 0.8 V/ns | | 0.6 V/ns | | 0.4V/ns | |
| | t_{DS} | t_{DH} | t_{DS} | t_{DH} | t_{DS} | t_{DH} | t_{DS} | t_{DH} | t_{DS} | t_{DH} | t_{DS} | t_{DH} | t_{DS} | t_{DH} | t_{DS} | t_{DH} | t_{DS} | t_{DH} |
| 2 | 330 | 291 | 330 | 291 | 330 | 291 | 330 | 291 | 330 | 291 | 345 | 286 | 355 | 282 | 365 | 29 | 375 | 276 |
| 1.5 | 330 | 290 | 330 | 290 | 330 | 290 | 330 | 290 | 330 | 290 | 345 | 285 | 355 | 282 | 365 | 279 | 375 | 275 |
| 1 | 330 | 290 | 330 | 290 | 330 | 290 | 330 | 290 | 330 | 290 | 345 | 285 | 355 | 282 | 365 | 278 | 375 | 275 |
| 0.9 | 347 | 290 | 347 | 290 | 347 | 290 | 347 | 290 | 347 | 290 | 362 | 285 | 372 | 282 | 382 | 278 | 392 | 275 |
| 0.8 | 367 | 290 | 367 | 290 | 367 | 290 | 367 | 290 | 367 | 290 | 382 | 285 | 392 | 282 | 402 | 278 | 412 | 275 |
| 0.7 | 391 | 290 | 391 | 290 | 391 | 290 | 391 | 290 | 391 | 290 | 406 | 285 | 416 | 281 | 426 | 278 | 436 | 275 |
| 0.6 | 426 | 290 | 426 | 290 | 426 | 290 | 426 | 290 | 426 | 290 | 441 | 285 | 451 | 282 | 461 | 278 | 471 | 275 |
| 0.5 | 472 | 290 | 472 | 290 | 472 | 290 | 472 | 290 | 472 | 290 | 487 | 285 | 497 | 282 | 507 | 278 | 517 | 275 |
| 0.4 | 522 | 289 | 522 | 289 | 522 | 289 | 522 | 289 | 522 | 289 | 537 | 284 | 547 | 281 | 557 | 278 | 567 | 274 |

Table 32: Single-Ended DQS Slew Rate Fully Derated (DQS, DQ at VREF) at DDR2-533
Reference points indicated in bold

| DQ (V/ns) | DQS Single-Ended Slew Rate Derated (at VREF) | | | | | | | | | | | | | | | | | |
|--------------|--|-----------------|-----------------|-----------------|-----------------|-----------------|-----------------|-----------------|-----------------|-----------------|-----------------|-----------------|-----------------|-----------------|-----------------|-----------------|-----------------|-----------------|
| | 2.0 V/ns | | 1.8 V/ns | | 1.6 V/ns | | 1.4 V/ns | | 1.2 V/ns | | 1.0 V/ns | | 0.8 V/ns | | 0.6 V/ns | | 0.4V/ns | |
| | t _{DS} | t _{DH} | t _{DS} | t _{DH} | t _{DS} | t _{DH} | t _{DS} | t _{DH} | t _{DS} | t _{DH} | t _{DS} | t _{DH} | t _{DS} | t _{DH} | t _{DS} | t _{DH} | t _{DS} | t _{DH} |
| 2 | 355 | 341 | 355 | 341 | 355 | 341 | 355 | 341 | 355 | 341 | 370 | 336 | 380 | 332 | 390 | 329 | 400 | 326 |
| 1.5 | 364 | 340 | 364 | 340 | 364 | 340 | 364 | 340 | 364 | 340 | 379 | 335 | 389 | 332 | 399 | 329 | 409 | 325 |
| 1 | 380 | 340 | 380 | 340 | 380 | 340 | 380 | 340 | 380 | 340 | 395 | 335 | 405 | 332 | 415 | 328 | 425 | 325 |
| 0.9 | 402 | 340 | 402 | 340 | 402 | 340 | 402 | 340 | 402 | 340 | 417 | 335 | 427 | 332 | 437 | 328 | 447 | 325 |
| 0.8 | 429 | 340 | 429 | 340 | 429 | 340 | 429 | 340 | 429 | 340 | 444 | 335 | 454 | 332 | 464 | 328 | 474 | 325 |
| 0.7 | 463 | 340 | 463 | 340 | 463 | 340 | 463 | 340 | 463 | 340 | 478 | 335 | 488 | 331 | 498 | 328 | 508 | 325 |
| 0.6 | 510 | 340 | 510 | 340 | 510 | 340 | 510 | 340 | 510 | 340 | 525 | 335 | 535 | 332 | 545 | 328 | 555 | 325 |
| 0.5 | 572 | 340 | 572 | 340 | 572 | 340 | 572 | 340 | 572 | 340 | 587 | 335 | 597 | 332 | 607 | 328 | 617 | 325 |
| 0.4 | 647 | 339 | 647 | 339 | 647 | 339 | 647 | 339 | 647 | 339 | 662 | 334 | 672 | 331 | 682 | 328 | 692 | 324 |

Table 33: Single-Ended DQS Slew Rate Fully Derated (DQS, DQ at VREF) at DDR2-400
Reference points indicated in bold

| DQ (V/ns) | DQS Single-Ended Slew Rate Derated (at VREF) | | | | | | | | | | | | | | | | | |
|--------------|--|-----------------|-----------------|-----------------|-----------------|-----------------|-----------------|-----------------|-----------------|-----------------|-----------------|-----------------|-----------------|-----------------|-----------------|-----------------|-----------------|-----------------|
| | 2.0 V/ns | | 1.8 V/ns | | 1.6 V/ns | | 1.4 V/ns | | 1.2 V/ns | | 1.0 V/ns | | 0.8 V/ns | | 0.6 V/ns | | 0.4V/ns | |
| | t _{DS} | t _{DH} | t _{DS} | t _{DH} | t _{DS} | t _{DH} | t _{DS} | t _{DH} | t _{DS} | t _{DH} | t _{DS} | t _{DH} | t _{DS} | t _{DH} | t _{DS} | t _{DH} | t _{DS} | t _{DH} |
| 2 | 405 | 391 | 405 | 391 | 405 | 391 | 405 | 391 | 405 | 391 | 420 | 386 | 430 | 382 | 440 | 379 | 450 | 376 |
| 1.5 | 414 | 390 | 414 | 390 | 414 | 390 | 414 | 390 | 414 | 390 | 429 | 385 | 439 | 382 | 449 | 379 | 459 | 375 |
| 1 | 430 | 390 | 430 | 390 | 430 | 390 | 430 | 390 | 430 | 390 | 445 | 385 | 455 | 382 | 465 | 378 | 475 | 375 |
| 0.9 | 452 | 390 | 452 | 390 | 452 | 390 | 452 | 390 | 452 | 390 | 467 | 385 | 477 | 382 | 487 | 378 | 497 | 375 |
| 0.8 | 479 | 390 | 479 | 390 | 479 | 390 | 479 | 390 | 479 | 390 | 494 | 385 | 504 | 382 | 514 | 378 | 524 | 375 |
| 0.7 | 513 | 390 | 513 | 390 | 513 | 390 | 513 | 390 | 513 | 390 | 528 | 385 | 538 | 381 | 548 | 378 | 558 | 375 |
| 0.6 | 560 | 390 | 560 | 390 | 560 | 390 | 560 | 390 | 560 | 390 | 575 | 385 | 585 | 382 | 595 | 378 | 605 | 375 |
| 0.5 | 622 | 390 | 622 | 390 | 622 | 390 | 622 | 390 | 622 | 390 | 637 | 385 | 647 | 382 | 657 | 378 | 667 | 375 |
| 0.4 | 697 | 389 | 697 | 389 | 697 | 389 | 697 | 389 | 697 | 389 | 712 | 384 | 722 | 381 | 732 | 378 | 742 | 374 |

Figure 75: Nominal Slew Rate for t_{DS}

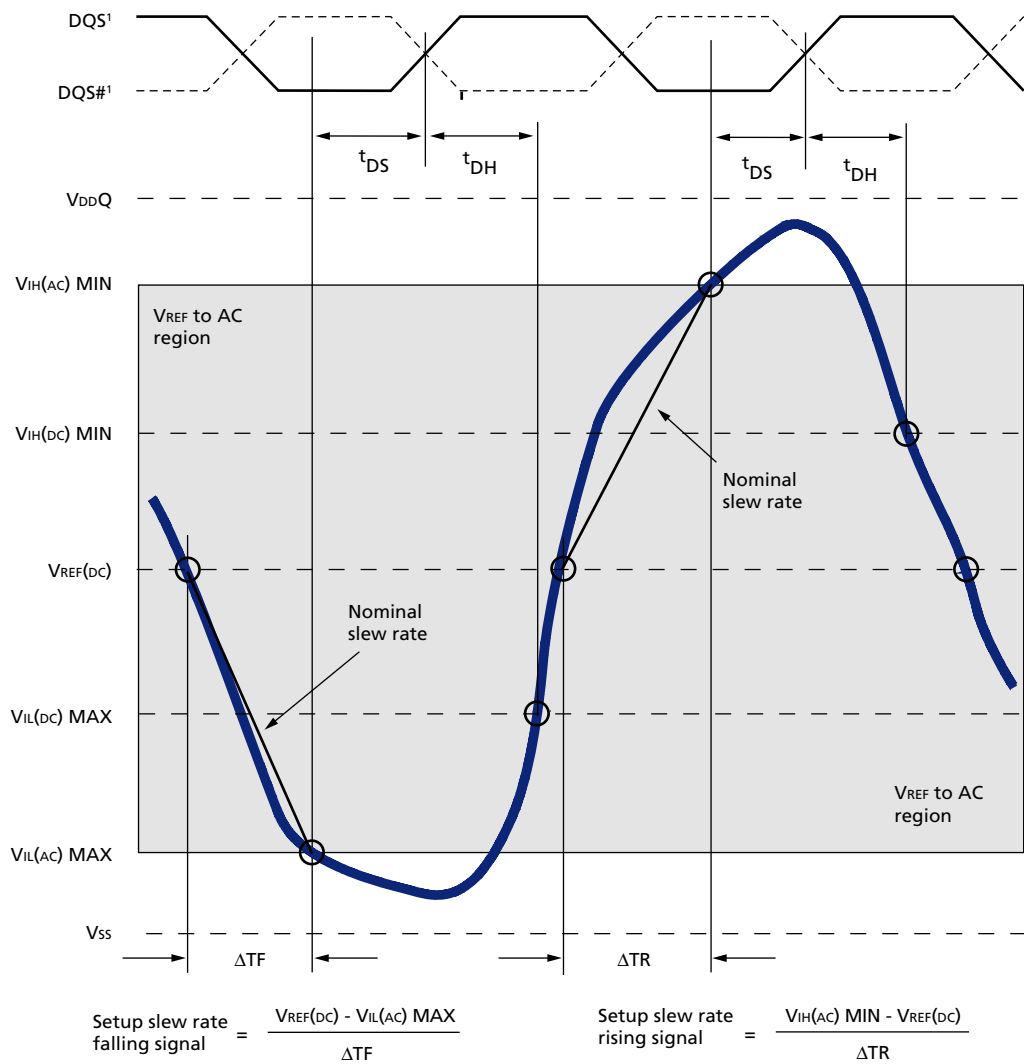

Notes: 1. DQS, DQS# signals must be monotonic between $V_{IL(DC) MAX}$ and $V_{IH(DC) MIN}$.

Figure 76: Tangent Line for t_{DS}

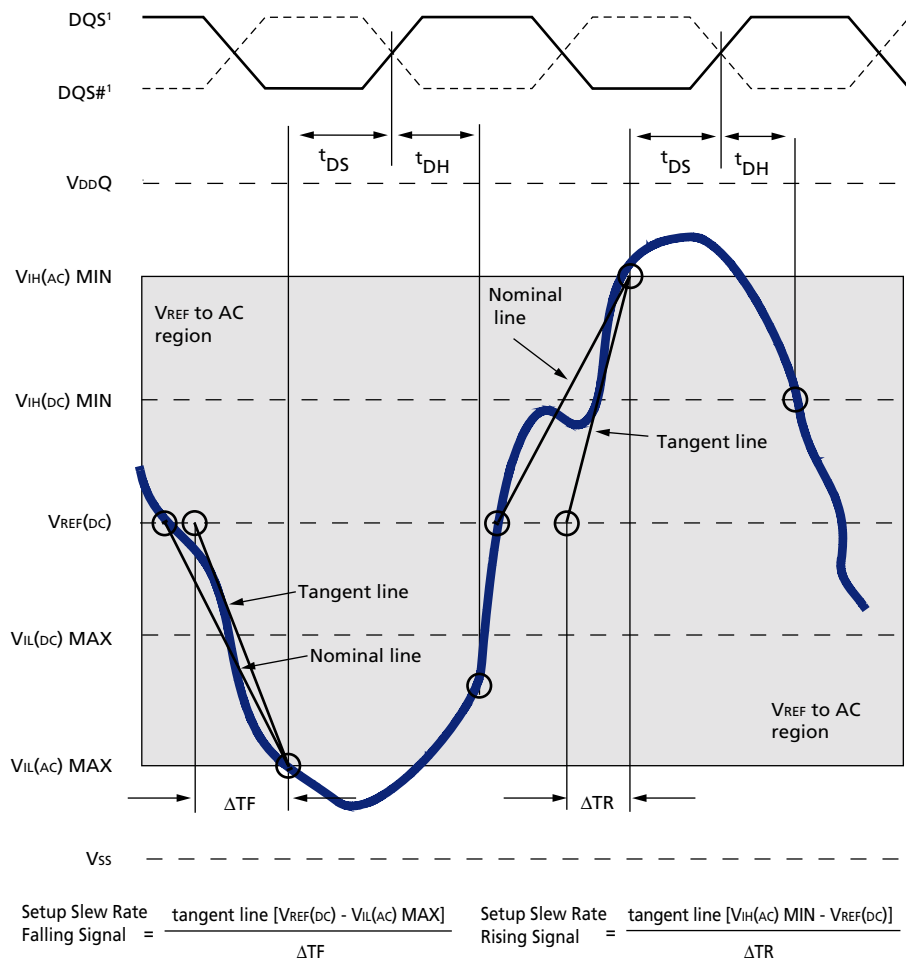

Notes: 1. DQS, DQS# signals must be monotonic between $V_{IL(DC) MAX}$ and $V_{IH(DC) MIN}$.

Figure 77: Nominal Slew Rate for t_{DH}

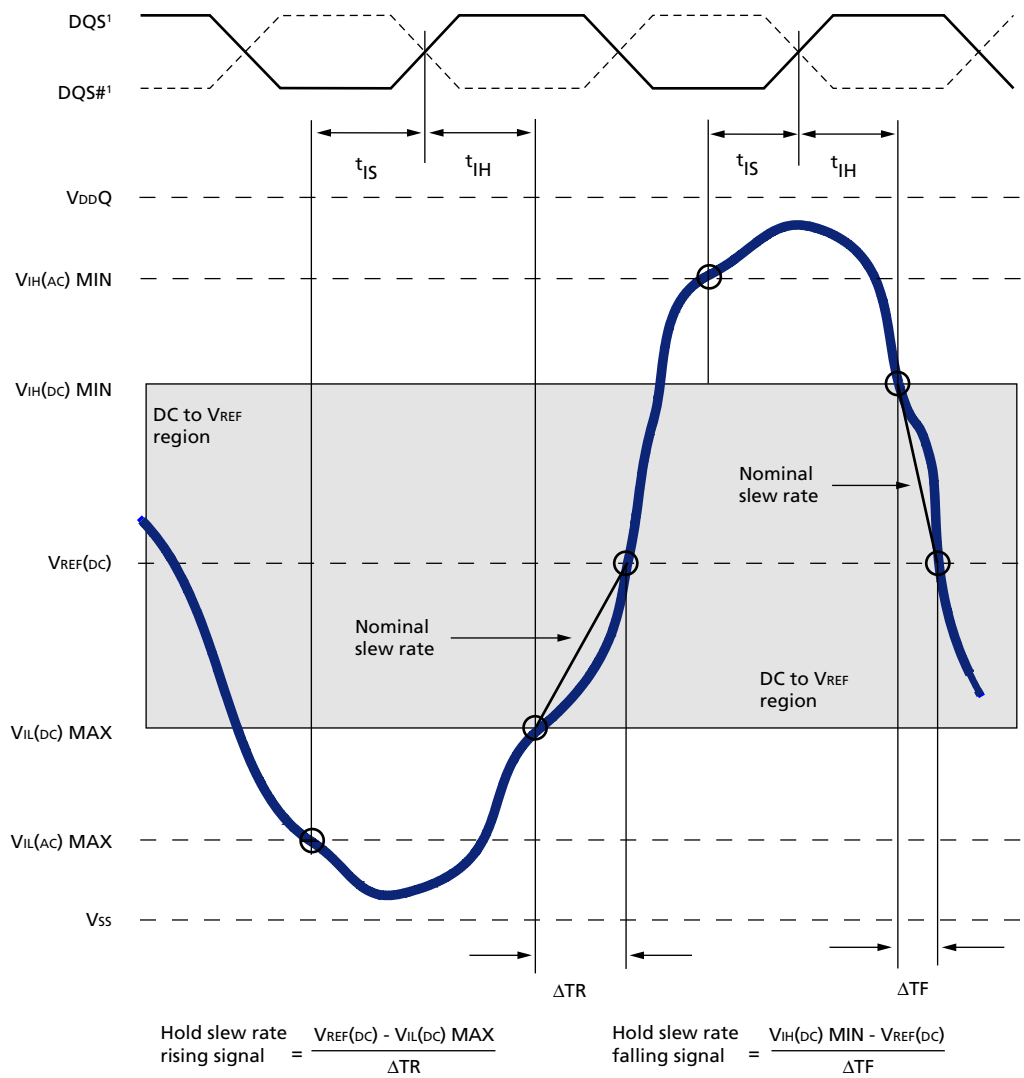

Notes: 1. DQS, DQS# signals must be monotonic between $V_{IL(DC) MAX}$ and $V_{IH(DC) MIN}$.

Figure 78: Tangent Line for t_{DH}

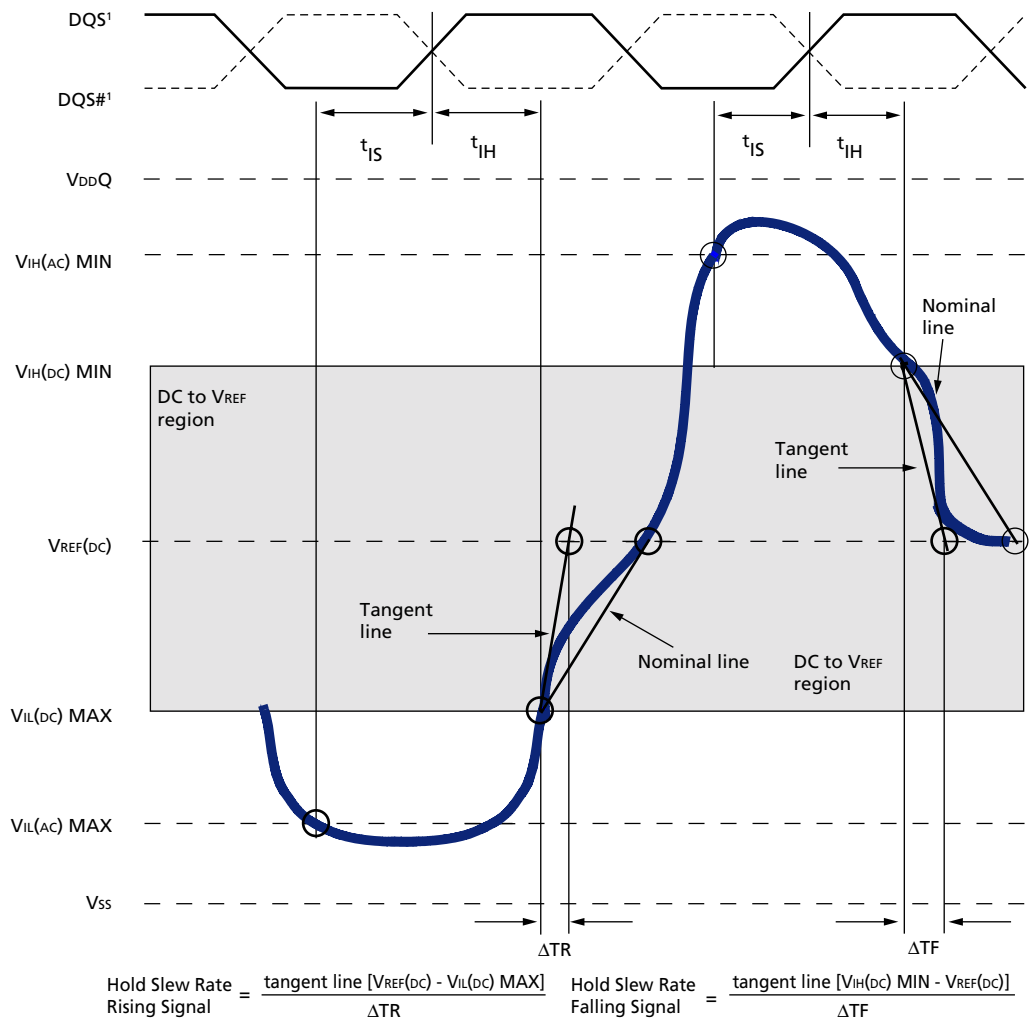

Notes: 1. DQS, DQS# signals must be monotonic between $V_{IL(DC) MAX}$ and $V_{IH(DC) MIN}$.

Figure 79: AC Input Test Signal Waveform Command/Address Balls

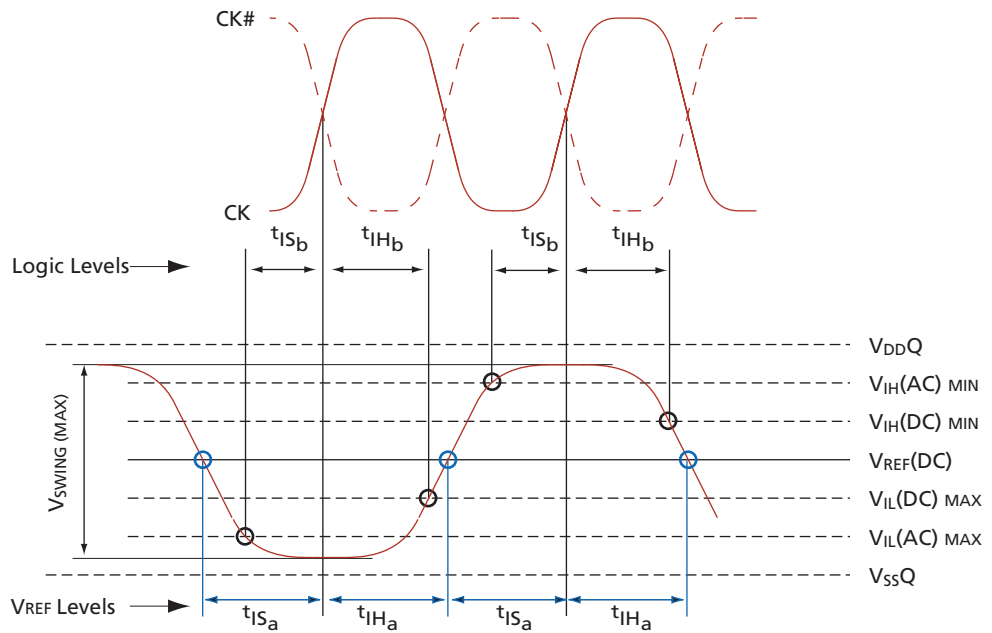

Figure 80: AC Input Test Signal Waveform for Data with DQS, DQS# (Differential)

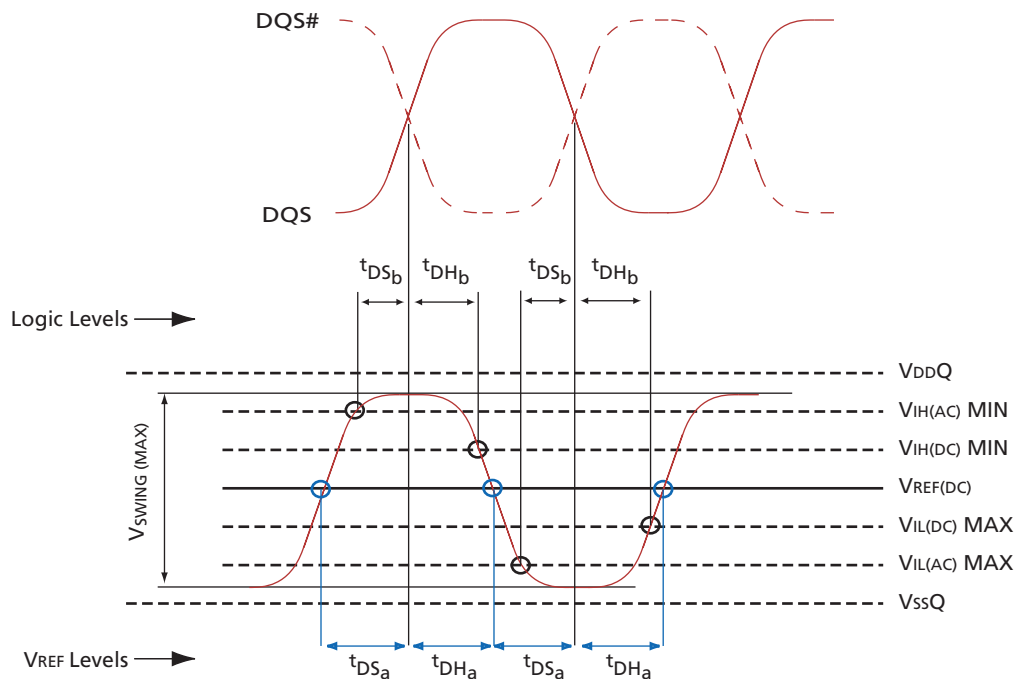

Figure 81: AC Input Test Signal Waveform for Data with DQS (single-ended)

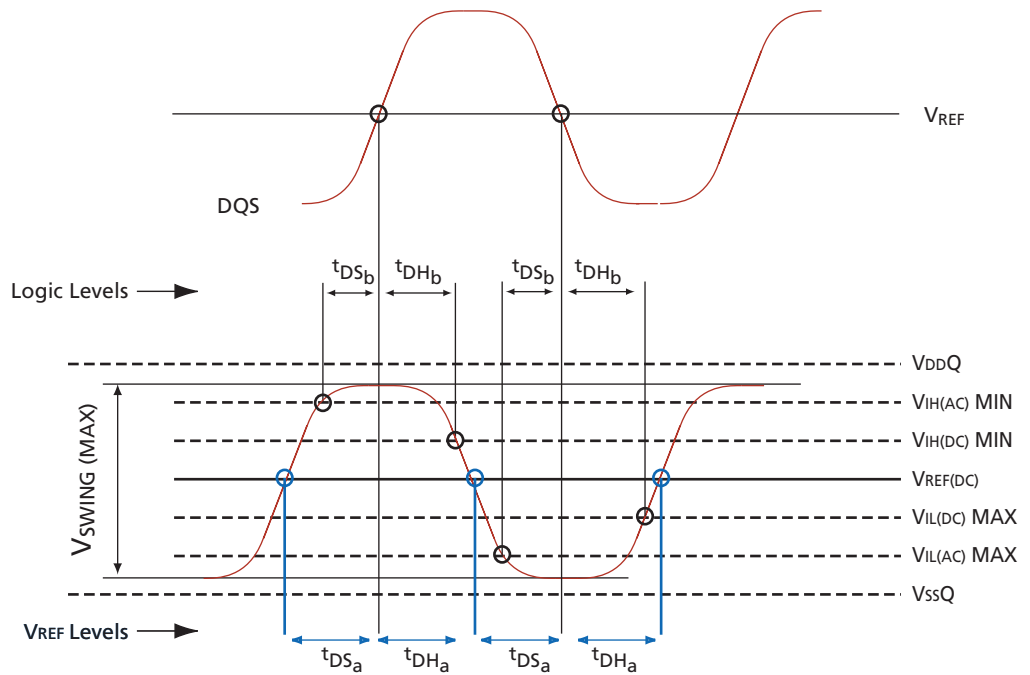
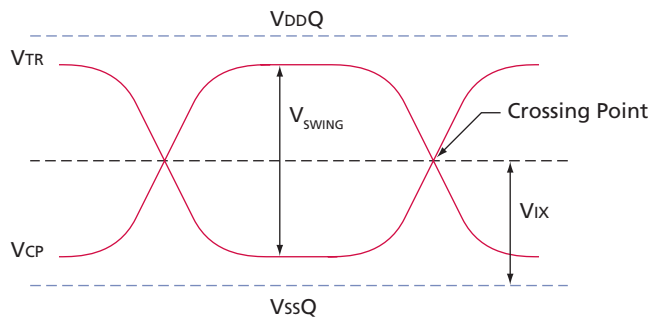

Figure 82: AC Input Test Signal Waveform (differential)



Power and Ground Clamp Characteristics

Power and ground clamps are provided on the following input-only balls: BA2–BA0, A0–A13 (x4, x8), A0–A12 (x16), CS#, RAS#, CAS#, WE#, ODT, and CKE.

Table 34: Input Clamp Characteristics

| Voltage Across Clamp (V) | Minimum Power Clamp Current (mA) | Minimum Ground Clamp Current (mA) |
|--------------------------|----------------------------------|-----------------------------------|
| 0.0 | 0.0 | 0.0 |
| 0.1 | 0.0 | 0.0 |
| 0.2 | 0.0 | 0.0 |
| 0.3 | 0.0 | 0.0 |
| 0.4 | 0.0 | 0.0 |
| 0.5 | 0.0 | 0.0 |
| 0.6 | 0.0 | 0.0 |
| 0.7 | 0.0 | 0.0 |
| 0.8 | 0.1 | 0.1 |
| 0.9 | 1.0 | 1.0 |
| 1.0 | 2.5 | 2.5 |
| 1.1 | 4.7 | 4.7 |
| 1.2 | 6.8 | 6.8 |
| 1.3 | 9.1 | 9.1 |
| 1.4 | 11.0 | 11.0 |
| 1.5 | 13.5 | 13.5 |
| 1.6 | 16.0 | 16.0 |
| 1.7 | 18.2 | 18.2 |
| 1.8 | 21.0 | 21.0 |

Figure 83: Input Clamp Characteristics

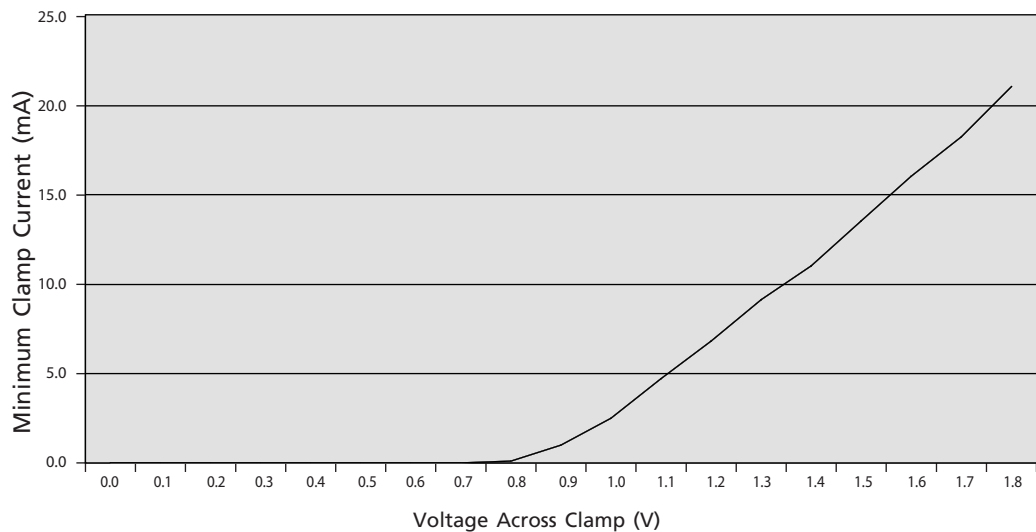

AC Overshoot/Undershoot Specification

Some revisions will support the 0.9V maximum average amplitude instead of the 0.5V maximum average amplitude that is shown in Table 35 and Table 36.

Table 35: Address and Control Balls

Applies to BA2–BA0, A0–A13 (x4, x8), A0–A12 (x16), CS#, RAS#, CAS#, WE#, CKE, ODT

| Parameter | Specification | | | |
|--|---------------|----------|----------|----------|
| | -5E | -37E | -3/-3E | -25/-25E |
| Maximum peak amplitude allowed for overshoot area (see Figure 84) | 0.50V | 0.50V | 0.50V | 0.50V |
| Maximum peak amplitude allowed for undershoot area (see Figure 85) | 0.50V | 0.50V | 0.50V | 0.50V |
| Maximum overshoot area above V_{DD} (see Figure 84) | 1.33 Vns | 1.00 Vns | 0.80 Vns | 0.66 Vns |
| Maximum undershoot area below V_{SS} (see Figure 85) | 1.33 Vns | 1.00 Vns | 0.80 Vns | 0.66 Vns |

Table 36: Clock, Data, Strobe, and Mask Balls

Applies to DQ, DQS, DQS#, RDQS, RDQS#, UDQS, UDQS#, LDQS, LDQS#, DM, UDM, LDM

| Parameter | Specification | | | |
|--|---------------|----------|----------|----------|
| | -5E | -37E | -3/-3E | -25/-25E |
| Maximum peak amplitude allowed for overshoot area (see Figure 84) | 0.50V | 0.50V | 0.50V | 0.50V |
| Maximum peak amplitude allowed for undershoot area (see Figure 85) | 0.50V | 0.50V | 0.50V | 0.50V |
| Maximum overshoot area above V_{DDQ} (see Figure 84) | 0.38 Vns | 0.28 Vns | 0.23 Vns | 0.19 Vns |
| Maximum undershoot area below V_{SSQ} (see Figure 85) | 0.38 Vns | 0.28 Vns | 0.23 Vns | 0.19 Vns |

Figure 84: Overshoot

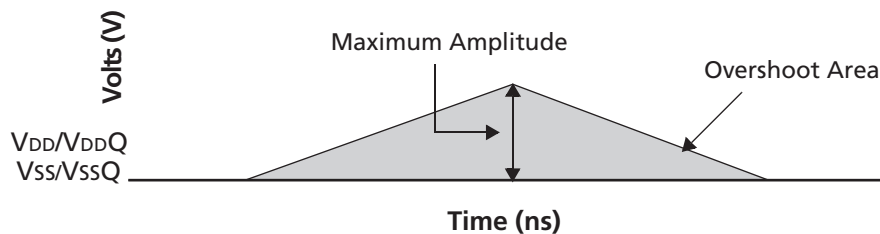
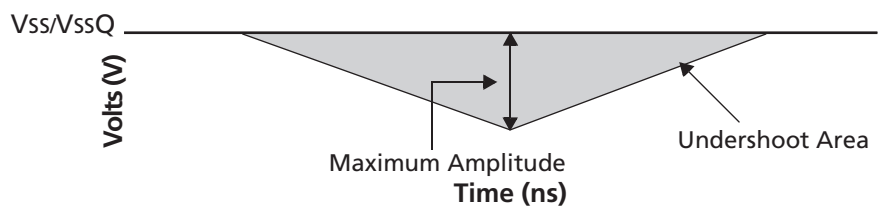

Figure 85: Undershoot



Output Electrical Characteristics and Operating Conditions

Table 37: Differential AC Output Parameters

| Parameter | Symbol | Min | Max | Units | Notes |
|-------------------------------------|--------------|-----------------------------|-----------------------------|-------|-------|
| AC differential cross-point voltage | $V_{OX(AC)}$ | $0.50 \times V_{DDQ} - 125$ | $0.50 \times V_{DDQ} + 125$ | mV | 1 |
| AC differential voltage swing | V_{SWING} | 1.0 | | mV | |

Notes: 1. The typical value of $V_{OX(AC)}$ is expected to be about $0.5 \times V_{DDQ}$ of the transmitting device and $V_{OX(AC)}$ is expected to track variations in V_{DDQ} . $V_{OX(AC)}$ indicates the voltage at which differential output signals must cross.

Figure 86: Differential Output Signal Levels

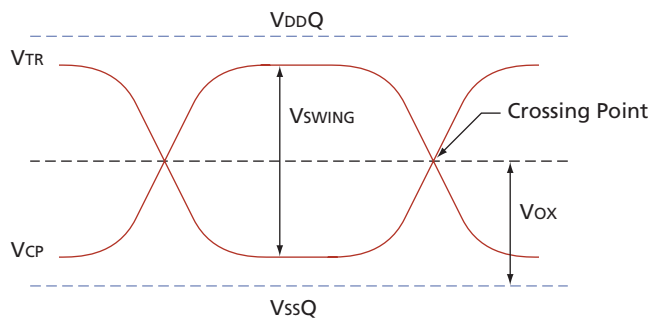

Table 38: Output DC Current Drive

| Parameter | Symbol | Value | Units | Notes |
|----------------------------------|-----------------|-------|-------|---------|
| Output minimum source DC current | I _{OH} | -13.4 | mA | 1, 2, 4 |
| Output minimum sink DC current | I _{OL} | 13.4 | mA | 2, 3, 4 |

- Notes:
- For I_{OH}(DC); V_{DDQ} = 1.7V, V_{OUT} = 1,420mV. (V_{OUT} - V_{DDQ})/I_{OH} must be less than 21Ω for values of V_{OUT} between V_{DDQ} and V_{DDQ} - 280mV.
 - For I_{OL}(DC); V_{DDQ} = 1.7V, V_{OUT} = 280mV. V_{OUT}/I_{OL} must be less than 21Ω for values of V_{OUT} between 0V and 280mV.
 - The DC value of V_{REF} applied to the receiving device is set to V_{TT}.
 - The values of I_{OH}(DC) and I_{OL}(DC) are based on the conditions given in Notes 1 and 2. They are used to test device drive current capability to ensure V_{IH} (MIN) plus a noise margin and V_{IL} (MAX) minus a noise margin are delivered to an SSTL_18 receiver. The actual current values are derived by shifting the desired driver operating point (see output IV curves) along a 21Ω load line to define a convenient driver current for measurement.

Table 39: Output Characteristics

| Parameter | Min | Nom | Max | Units | Notes |
|--------------------------------|--|-----|-----|-------|------------|
| Output impedance | See "Full Strength Pull-Down Driver Characteristics" on page 113 | | | Ω | 1, 2 |
| Pull-up and pull-down mismatch | 0 | | 4 | Ω | 1, 2, 3 |
| Output slew rate | 1.5 | | 5 | V/ns | 1, 4, 5, 6 |

- Notes:
- Absolute specifications: 0°C ≤ T_C ≤ +85°C; V_{DDQ} = +1.8V ±0.1V, V_{DD} = +1.8V ±0.1V.
 - Impedance measurement conditions for output source DC current: V_{DDQ} = 1.7V; V_{OUT} = 1,420mV; (V_{OUT} - V_{DDQ})/I_{OH} must be less than 23.4Ω for values of V_{OUT} between V_{DDQ} and V_{DDQ} - 280mV. Impedance measurement condition for output sink DC current: V_{DDQ} = 1.7V; V_{OUT} = 280mV; V_{OUT}/I_{OL} must be less than 23.4Ω for values of V_{OUT} between 0V and 280mV.
 - Mismatch is absolute value between pull-up and pull-down; both are measured at same temperature and voltage.
 - Output slew rate for falling and rising edges is measured between V_{TT} - 250mV and V_{TT} + 250mV for single-ended signals. For differential signals (DQS - DQS#), output slew rate is measured between DQS - DQS# = -500mV and DQS# - DQS = +500mV. Output slew rate is guaranteed by design, but is not necessarily tested on each device.
 - The absolute value of the slew rate as measured from V_{IL}(DC) MAX to V_{IH}(DC) MIN is equal to or greater than the slew rate as measured from V_{IL}(AC) MAX to V_{IH}(AC) MIN. This is guaranteed by design and characterization.
 - IT devices require an additional 0.4 V/ns in the MAX limit when T_C is between -40°C and 0°C.

Figure 87: Output Slew Rate Load

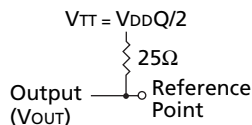

Full Strength Pull-Down Driver Characteristics

Figure 88: Full Strength Pull-Down Characteristics

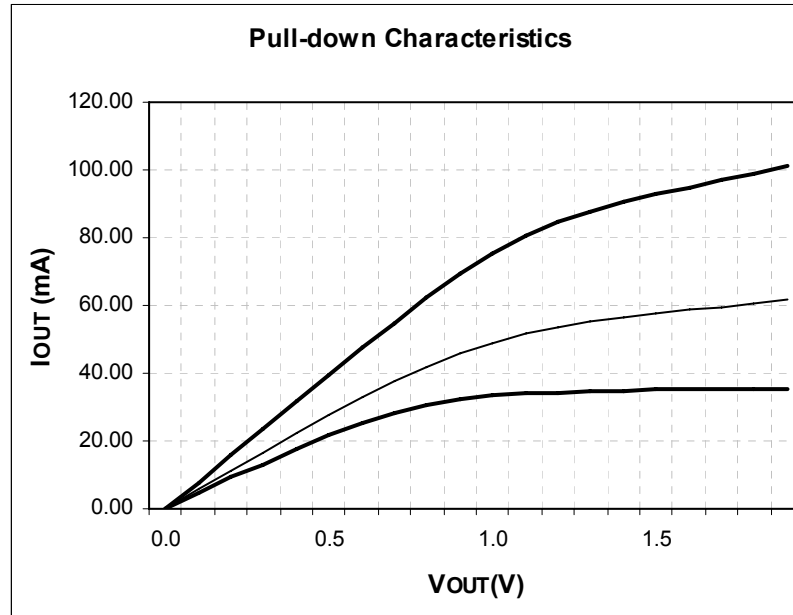

Table 40: Full Strength Pull-Down Current (mA)

| Voltage (V) | Minimum | Nominal | Maximum |
|-------------|---------|---------|---------|
| 0.0 | 0.00 | 0.00 | 0.00 |
| 0.1 | 4.3 | 5.63 | 7.95 |
| 0.2 | 8.6 | 11.3 | 15.90 |
| 0.3 | 12.9 | 16.52 | 23.85 |
| 0.4 | 16.9 | 22.19 | 31.80 |
| 0.5 | 20.4 | 27.59 | 39.75 |
| 0.6 | 23.28 | 32.39 | 47.70 |
| 0.7 | 25.44 | 36.45 | 55.55 |
| 0.8 | 26.79 | 40.38 | 62.95 |
| 0.9 | 27.67 | 44.01 | 69.55 |
| 1.0 | 28.38 | 47.01 | 75.35 |
| 1.1 | 28.96 | 49.63 | 80.35 |
| 1.2 | 29.46 | 51.71 | 84.55 |
| 1.3 | 29.90 | 53.32 | 87.95 |
| 1.4 | 30.29 | 54.9 | 90.70 |
| 1.5 | 30.65 | 56.03 | 93.00 |
| 1.6 | 30.98 | 57.07 | 95.05 |
| 1.7 | 31.31 | 58.16 | 97.05 |
| 1.8 | 31.64 | 59.27 | 99.05 |
| 1.9 | 31.96 | 60.35 | 101.05 |

Full Strength Pull-Up Driver Characteristics

Figure 89: Full Strength Pull-Up Characteristics

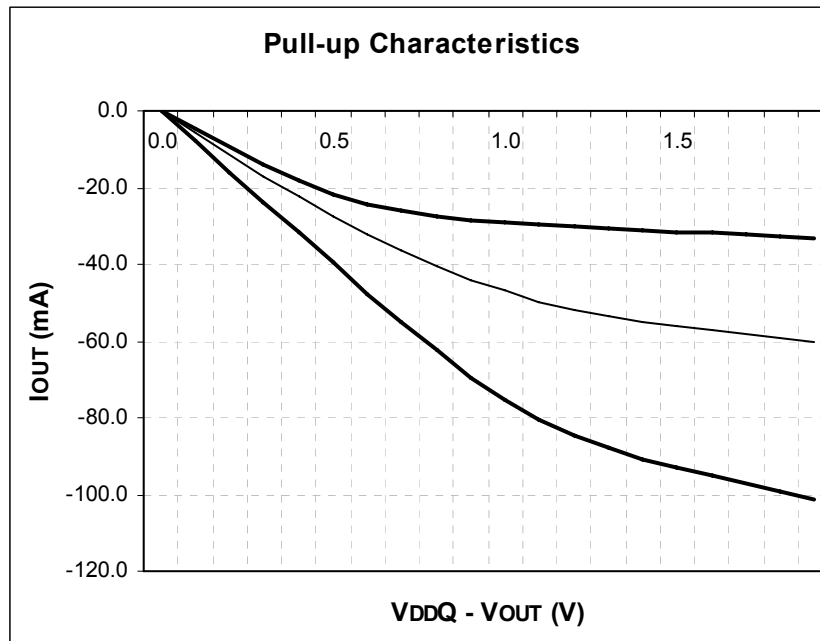

Table 41: Full Strength Pull-Up Current (mA)

| Voltage (V) | Minimum | Nominal | Maximum |
|-------------|---------|---------|---------|
| 0.0 | 0.00 | 0.00 | 0.00 |
| 0.1 | -4.3 | -5.63 | -7.95 |
| 0.2 | -8.6 | -11.3 | -15.90 |
| 0.3 | -12.9 | -16.52 | -23.85 |
| 0.4 | -16.9 | -22.19 | -31.80 |
| 0.5 | -20.4 | -27.59 | -39.75 |
| 0.6 | -23.28 | -32.39 | -47.70 |
| 0.7 | -25.44 | -36.45 | -55.55 |
| 0.8 | -26.79 | -40.38 | -62.95 |
| 0.9 | -27.67 | -44.01 | -69.55 |
| 1.0 | -28.38 | -47.01 | -75.35 |
| 1.1 | -28.96 | -49.63 | -80.35 |
| 1.2 | -29.46 | -51.71 | -84.55 |
| 1.3 | -29.90 | -53.32 | -87.95 |
| 1.4 | -30.29 | -54.90 | -90.70 |
| 1.5 | -30.65 | -56.03 | -93.00 |
| 1.6 | -30.98 | -57.07 | -95.05 |
| 1.7 | -31.31 | -58.16 | -97.05 |
| 1.8 | -31.64 | -59.27 | -99.05 |
| 1.9 | -31.96 | -60.35 | -101.05 |

Reduced Strength Pull-Down Driver Characteristics

Figure 90: Reduced Strength Pull-Down Characteristics

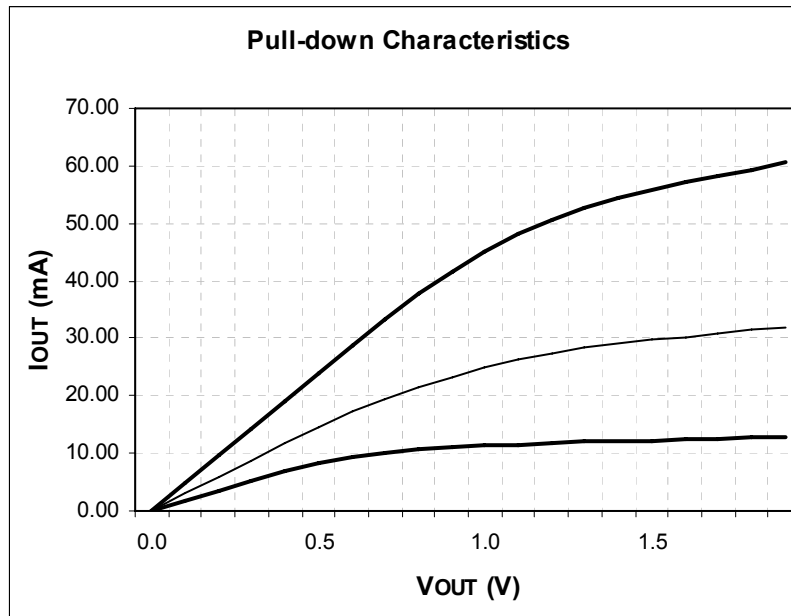

Table 42: Reduced Strength Pull-Down Current (mA)

| Voltage (V) | Minimum | Nominal | Maximum |
|-------------|---------|---------|---------|
| 0.0 | 0.00 | 0.00 | 0.00 |
| 0.1 | 1.72 | 2.98 | 4.77 |
| 0.2 | 3.44 | 5.99 | 9.54 |
| 0.3 | 5.16 | 8.75 | 14.31 |
| 0.4 | 6.76 | 11.76 | 19.08 |
| 0.5 | 8.16 | 14.62 | 23.85 |
| 0.6 | 9.31 | 17.17 | 28.62 |
| 0.7 | 10.18 | 19.32 | 33.33 |
| 0.8 | 10.72 | 21.40 | 37.77 |
| 0.9 | 11.07 | 23.32 | 41.73 |
| 1.0 | 11.35 | 24.92 | 45.21 |
| 1.1 | 11.58 | 26.30 | 48.21 |
| 1.2 | 11.78 | 27.41 | 50.73 |
| 1.3 | 11.96 | 28.26 | 52.77 |
| 1.4 | 12.12 | 29.10 | 54.42 |
| 1.5 | 12.26 | 29.70 | 55.80 |
| 1.6 | 12.39 | 30.25 | 57.03 |
| 1.7 | 12.52 | 30.82 | 58.23 |
| 1.8 | 12.66 | 31.41 | 59.43 |
| 1.9 | 12.78 | 31.98 | 60.63 |

Reduced Strength Pull-Up Driver Characteristics

Figure 91: Reduced Strength Pull-Up Characteristics

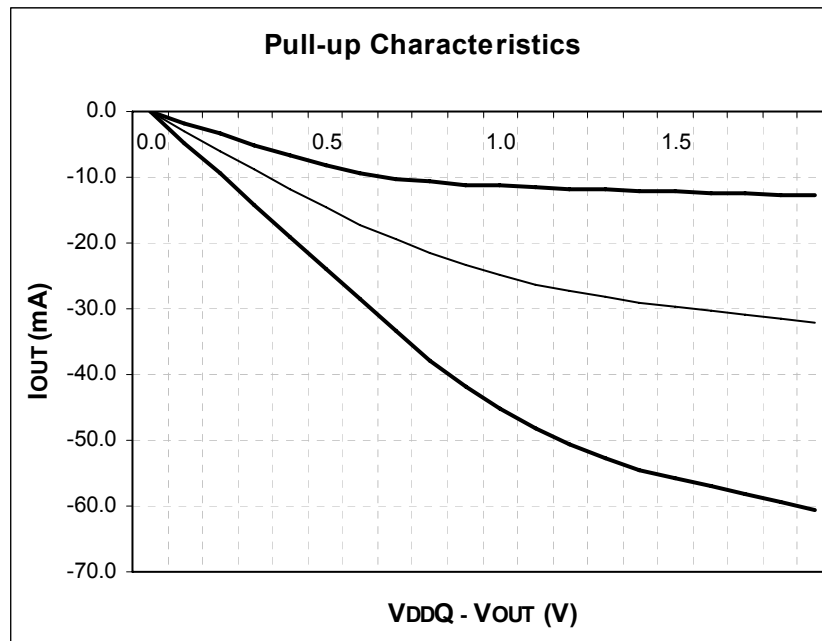

Table 43: Reduced Strength Pull-Up Current (mA)

| Voltage (V) | Minimum | Nominal | Maximum |
|-------------|---------|---------|---------|
| 0.0 | 0.00 | 0.00 | 0.00 |
| 0.1 | -1.72 | -2.98 | -4.77 |
| 0.2 | -3.44 | -5.99 | -9.54 |
| 0.3 | -5.16 | -8.75 | -14.31 |
| 0.4 | -6.76 | -11.76 | -19.08 |
| 0.5 | -8.16 | -14.62 | -23.85 |
| 0.6 | -9.31 | -17.17 | -28.62 |
| 0.7 | -10.18 | -19.32 | -33.33 |
| 0.8 | -10.72 | -21.40 | -37.77 |
| 0.9 | -11.07 | -23.32 | -41.73 |
| 1.0 | -11.35 | -24.92 | -45.21 |
| 1.1 | -11.58 | -26.30 | -48.21 |
| 1.2 | -11.78 | -27.41 | -50.73 |
| 1.3 | -11.96 | -28.26 | -52.77 |
| 1.4 | -12.12 | -29.10 | -54.42 |
| 1.5 | -12.26 | -29.69 | -55.8 |
| 1.6 | -12.39 | -30.25 | -57.03 |
| 1.7 | -12.52 | -30.82 | -58.23 |
| 1.8 | -12.66 | -31.42 | -59.43 |
| 1.9 | -12.78 | -31.98 | -60.63 |

FBGA Package Capacitance

Table 44: Input Capacitance

| Parameter | Symbol | Min | Max | Units | Notes |
|--|--------|-----|------|-------|-------|
| Input capacitance: CK, CK# | CCK | 1.0 | 2.0 | pF | 1 |
| Delta input capacitance: CK, CK# | CDCK | – | 0.25 | pF | 2 |
| Input capacitance: BA2–BA0, A0–A13 (A0–A12 on x16), CS#, RAS#, CAS#, WE#, CKE, ODT | CI | 1.0 | 2.0 | pF | 1 |
| Delta input capacitance: BA2–BA0, A0–A13 (A0–A12 on x16), CS#, RAS#, CAS#, WE#, CKE, ODT | CDI | – | 0.25 | pF | 2 |
| Input/Output capacitance: DQs, DQS, DM, NF | CIO | 2.5 | 4.0 | pF | 1, 4 |
| Delta input/output capacitance: DQs, DQS, DM, NF | CDIO | – | 0.5 | pF | 3 |

- Notes:
1. This parameter is sampled. $V_{DD} = +1.8V \pm 0.1V$, $V_{DDQ} = +1.8V \pm 0.1V$, $V_{REF} = V_{SS}$, $f = 100$ MHz, $T_C = 25^\circ\text{C}$, $V_{OUT}(\text{DC}) = V_{DDQ}/2$, V_{OUT} (peak-to-peak) = 0.1V. DM input is grouped with I/O balls, reflecting the fact that they are matched in loading.
 2. The input capacitance per ball group will not differ by more than this maximum amount for any given device.
 3. The I/O capacitance per DQS and DQ byte/group will not differ by more than this maximum amount for any given device.
 4. Reduce MAX limit by 0.5pF for -3/-3E/-25/-25E speed devices.
 5. Reduce MAX limit by 0.25pF for -3/-3E/-25/-25E speed devices.

IDD Specifications and Conditions

Table 45: DDR2 IDD Specifications and Conditions (continued)

Notes: 1–7; notes appear on page 119

| Parameter/Condition | Sym | Config | -25E | -25 | -3E/-3 | -37E | -5E | Units |
|--|-------|-----------------------------|------|-----|--------|------|-----|-------|
| Operating one bank active-precharge current: $t_{CK} = t_{CK} (IDD)$, $t_{RC} = t_{RC} (IDD)$, $t_{RAS} = t_{RAS} MIN (IDD)$; CKE is HIGH, CS# is HIGH between valid commands; Address bus inputs are switching; Data bus inputs are switching | IDD0 | x4, x8 | 100 | 100 | 90 | 80 | 70 | mA |
| | | x16 | 150 | 150 | 135 | 110 | 110 | |
| Operating one bank active-read-precharge current: $I_{OUT} = 0mA$; BL = 4, CL = CL (IDD), AL = 0; $t_{CK} = t_{CK} (IDD)$, $t_{RC} = t_{RC} (IDD)$, $t_{RAS} = t_{RAS} MIN (IDD)$, $t_{RCD} = t_{RCD} (IDD)$; CKE is HIGH, CS# is HIGH between valid commands; Address bus inputs are switching; Data pattern is same as IDD4W | IDD1 | x4, x8 | 110 | 110 | 100 | 95 | 80 | mA |
| | | x16 | 175 | 175 | 130 | 120 | 115 | |
| Precharge power-down current: All banks idle; $t_{CK} = t_{CK} (IDD)$; CKE is LOW; Other control and address bus inputs are stable; Data bus inputs are floating | IDD2P | x4, x8, x16 | 7 | 7 | 7 | 7 | 7 | mA |
| Precharge quiet standby current: All banks idle; $t_{CK} = t_{CK} (IDD)$; CKE is HIGH, CS# is HIGH; Other control and address bus inputs are stable; Data bus inputs are floating | IDD2Q | x4, x8 | 65 | 65 | 55 | 41 | 35 | mA |
| | | x16 | 75 | 75 | 65 | 45 | 40 | |
| Precharge standby current: All banks idle; $t_{CK} = t_{CK} (IDD)$; CKE is HIGH, CS# is HIGH; Other control and address bus inputs are switching; Data bus inputs are switching | IDD2N | x4, x8 | 70 | 70 | 60 | 45 | 40 | mA |
| | | x16 | 80 | 80 | 70 | 50 | 40 | |
| Active power-down current: All banks open; $t_{CK} = t_{CK} (IDD)$; CKE is LOW; Other control and address bus inputs are stable; Data bus inputs are floating | IDD3P | Fast PDN exit MR[12] = 0 | 45 | 45 | 40 | 30 | 25 | mA |
| | | Slow PDN exit MR[12] = 1 | 10 | 10 | 10 | 10 | 10 | |
| Active standby current: All banks open; $t_{CK} = t_{CK} (IDD)$, $t_{RAS} = t_{RAS} MAX (IDD)$, $t_{RP} = t_{RP} (IDD)$; CKE is HIGH, CS# is HIGH between valid commands; Other control and address bus inputs are switching; Data bus inputs are switching | IDD3N | x4, x8 | 75 | 75 | 70 | 55 | 45 | mA |
| | | x16 | 85 | 85 | 75 | 60 | 55 | |
| Operating burst write current: All banks open, continuous burst writes; BL = 4, CL = CL (IDD), AL = 0; $t_{CK} = t_{CK} (IDD)$, $t_{RAS} = t_{RAS} MAX (IDD)$, $t_{RP} = t_{RP} (IDD)$; CKE is HIGH, CS# is HIGH between valid commands; Address bus inputs are switching; Data bus inputs are switching | IDD4W | x4, x8 | 185 | 185 | 160 | 130 | 110 | mA |
| | | x16 | 315 | 315 | 200 | 180 | 160 | |
| Operating burst read current: All banks open, continuous burst reads, $I_{OUT} = 0mA$; BL = 4, CL = CL (IDD), AL = 0; $t_{CK} = t_{CK} (IDD)$, $t_{RAS} = t_{RAS} MAX (IDD)$, $t_{RP} = t_{RP} (IDD)$; CKE is HIGH, CS# is HIGH between valid commands; Address bus inputs are switching; Data bus inputs are switching | IDD4R | x4, x8 | 190 | 190 | 160 | 145 | 110 | mA |
| | | x16 | 320 | 320 | 220 | 180 | 160 | |
| Burst refresh current: $t_{CK} = t_{CK} (IDD)$; refresh command at every $t_{RFC} (IDD)$ interval; CKE is HIGH, CS# is HIGH between valid commands; Other control and address bus inputs are switching; Data bus inputs are switching | IDD5 | x4, x8 | 280 | 280 | 260 | 250 | 220 | mA |
| | | x16 | 280 | 280 | 270 | 250 | 240 | |
| Self refresh current: CK and CK# at 0V; CKE $\leq 0.2V$; Other control and address bus inputs are floating; Data bus inputs are floating | IDD6 | x4, x8, x16 | 7 | 7 | 7 | 7 | 7 | mA |
| | IDD6L | | 3 | 3 | 3 | 3 | 3 | |

Table 45: DDR2 IDD Specifications and Conditions (continued)

Notes: 1–7; notes appear on page 119

| Parameter/Condition | Sym | Config | -25E | -25 | -3E/-3 | -37E | -5E | Units |
|---|------|--------|------|-----|--------|------|-----|-------|
| Operating bank interleave read current: All bank interleaving reads, I _{OUT} = 0mA; BL = 4, CL = CL (IDD), AL = t _{RCD} (IDD) - 1 x t _{CK} (IDD); t _{CK} = t _{CK} (IDD), t _{RC} = t _{RC} (IDD), t _{RRD} = t _{RRD} (IDD), t _{RCD} = t _{RCD} (IDD); CKE is HIGH, CS# is HIGH between valid commands; Address bus inputs are stable during deselects; Data bus inputs are switching (see Table 47 on page 120 for details) | IDD7 | x4, x8 | 335 | 335 | 300 | 290 | 260 | mA |
| | | x16 | 440 | 430 | 350 | 330 | 300 | |

- Notes:
- IDD specifications are tested after the device is properly initialized. $0^{\circ}\text{C} \leq T_C \leq +85^{\circ}\text{C}$.
 $V_{DD} = +1.8\text{V} \pm 0.1\text{V}$, $V_{DDQ} = +1.8\text{V} \pm 0.1\text{V}$, $V_{DDL} = +1.8\text{V} \pm 0.1\text{V}$, $V_{REF} = V_{DDQ}/2$.
 $-37\text{V } V_{DDQ} = +1.9\text{V} \pm 0.1\text{V}$, $V_{DDL} = +1.9\text{V} \pm 0.1$.
 - Input slew rate is specified by AC parametric test conditions (Table 46 on page 120).
 - IDD parameters are specified with ODT disabled.
 - Data bus consists of DQ, DM, DQS, DQS#, RDQS, RDQS#, LDQS, LDQS#, UDQS, and UDQS#. IDD values must be met with all combinations of EMR bits 10 and 11.
 - Definitions for IDD conditions:
 - LOW $V_{IN} \leq V_{IL(AC)}$ MAX
 - HIGH $V_{IN} \geq V_{IH(AC)}$ MIN
 - Stable Inputs stable at a HIGH or LOW level
 - Floating Inputs at $V_{REF} = V_{DDQ}/2$
 - Switching Inputs changing between HIGH and LOW every other clock cycle (once per two clocks) for address and control signals
 - Switching Inputs changing between HIGH and LOW every other data transfer (once per clock) for DQ signals, not including masks or strobes
 - IDD1, IDD4R, and IDD7 require A12 in EMR1 to be enabled during testing.
 - The following IDDs must be derated (IDD limits increase) on IT-option devices when operated outside of the range $0^{\circ}\text{C} \leq T_C \leq 85^{\circ}\text{C}$:
 - When $T_C \leq 0^{\circ}\text{C}$ IDD2P and IDD3P (slow) must be derated by 4 percent; IDD4R and IDD5W must be derated by 2 percent; and IDD6 and IDD7 must be derated by 7 percent
 - When $T_C \geq 85^{\circ}\text{C}$ IDD0, IDD1, IDD2N, IDD2Q, IDD3N, IDD3P (fast), IDD4R, IDD4W, and IDD5W must be derated by 2 percent; IDD2P must be derated by 20 percent; IDD3Pslow must be derated by 30 percent; and IDD6 must be derated by 80 percent (IDD6 will increase by this amount if $T_C < 85^{\circ}\text{C}$ and the 2x refresh option is still enabled)

Table 46: General IDD Parameters

| IDD Parameter | -25E | -25 | -3E | -3 | -37E | -5E | Units |
|--------------------------------------|--------|--------|--------|--------|--------|--------|-----------------|
| CL (IDD) | 5 | 6 | 4 | 5 | 4 | 3 | ^t CK |
| ^t RCD (IDD) | 12.5 | 15 | 12 | 15 | 15 | 15 | ns |
| ^t RC (IDD) | 57.5 | 60 | 57 | 60 | 60 | 55 | ns |
| ^t RRD (IDD) - x4/x8 (1KB) | 7.5 | 7.5 | 7.5 | 7.5 | 7.5 | 7.5 | ns |
| ^t RRD (IDD) - x16 (2KB) | 10 | 10 | 10 | 10 | 10 | 10 | ns |
| ^t CK (IDD) | 2.5 | 2.5 | 3 | 3 | 3.75 | 5 | ns |
| ^t RAS MIN (IDD) | 45 | 45 | 45 | 45 | 45 | 40 | ns |
| ^t RAS MAX (IDD) | 70,000 | 70,000 | 70,000 | 70,000 | 70,000 | 70,000 | ns |
| ^t RP (IDD) | 12.5 | 15 | 12 | 15 | 15 | 15 | ns |
| ^t RFC (IDD) | 127.5 | 127.5 | 127.5 | 127.5 | 127.5 | 127.5 | ns |
| ^t FAW (1KB) (IDD) | 35 | 35 | 37.5 | 37.5 | 37.5 | 37.5 | ns |
| ^t FAW (2KB) (IDD) | 45 | 45 | 50 | 50 | 50 | 50 | ns |

IDD7 Conditions

The detailed timings are shown below for IDD7. Changes will be required if timing parameter changes are made to the specification. Where general IDD parameters in Table 46 on page 120 conflict with pattern requirements of Table 47, then Table 47 requirements take precedence.

Table 47: IDD7 Timing Patterns (8-bank)

All bank interleave READ operation

| Speed Grade | IDD7 Timing Patterns for x4/x8/x16 |
|--|---|
| Timing Patterns for 8-bank devices x4/x8 | |
| -5E | A0 RA0 A1 RA1 A2 RA2 A3 RA3 A4 RA4 A5 RA5 A6 RA6 A7 RA7 |
| -37E | A0 RA0 A1 RA1 A2 RA2 A3 RA3 D D A4 RA4 A5 RA5 A6 RA6 A7 RA7 D D |
| -3 | A0 RA0 D A1 RA1 D A2 RA2 D A3 RA3 D D A4 RA4 D A5 RA5 D A6 RA6 D A7 RA7 D D |
| -3E | A0 RA0 D A1 RA1 D A2 RA2 D A3 RA3 D D A4 RA4 D A5 RA5 D A6 RA6 D A7 RA7 D D |
| -25 | A0 RA0 D A1 RA1 D A2 RA2 D A3 RA3 D D D A4 RA4 D A5 RA5 D A6 RA6 D A7 RA7 D D D |
| -25E | A0 RA0 D A1 RA1 D A2 RA2 D A3 RA3 D D D A4 RA4 D A5 RA5 D A6 RA6 D A7 RA7 D D D |
| Timing Patterns for 8-bank devices x16 | |
| -5E | A0 RA0 A1 RA1 A2 RA2 A3 RA3 D D A4 RA4 A5 RA5 A6 RA6 A7 RA7 D D |
| -37E | A0 RA0 D A1 RA1 D A2 RA2 D A3 RA3 D D D A4 RA4 D A5 RA5 D A6 RA6 D A7 RA7 D D D |
| -3 | A0 RA0 D D A1 RA1 D D A2 RA2 D D A3 RA3 D D D A4 RA4 D D A5 RA5 D D A6 RA6 D D A7 RA7 D D D |
| -3E | A0 RA0 D D A1 RA1 D D A2 RA2 D D A3 RA3 D D D A4 RA4 D D A5 RA5 D D A6 RA6 D D A7 RA7 D D D |
| -25 | A0 RA0 D D A1 RA1 D D A2 RA2 D D A3 RA3 D D D D A4 RA4 D D A5 RA5 D D A6 RA6 D D A7 RA7 D D D D |
| -25E | A0 RA0 D D A1 RA1 D D A2 RA2 D D A3 RA3 D D D D A4 RA4 D D A5 RA5 D D A6 RA6 D D A7 RA7 D D D D |

- Notes:
1. A = active; RA = read auto precharge; D = deselect.
 2. All banks are being interleaved at minimum ^tRC (IDD) without violating ^tRRD (IDD) using a BL = 4.
 3. Control and address bus inputs are STABLE during DESELECTS.
 4. IOUT = 0mA.

AC Operating Specifications

Table 48: AC Operating Conditions for -3E, -3, -37E, and -5E Speeds (Sheet 1 of 6)

Notes: 1–5; notes appear on page 131; VDDQ = +1.8V ±0.1V, VDD = +1.8V ±0.1V

| AC Characteristics | | | -3E | | -3 | | -37E | | -5E | | Units | Notes | |
|--------------------|---------------------------------------|-----------------------------------|--|--|--|--|--|--|--|--|----------|--------|----------------|
| Parameter | Symbol | Min | Max | Min | Max | Min | Max | Min | Max | | | | |
| Clock | Clock cycle time | CL = 5 | $t_{CK_{AVG}(5)}$ | 3,000 | 8,000 | 3,000 | 8,000 | – | – | – | – | ps | 16, 22, 36, 38 |
| | | CL = 4 | $t_{CK_{AVG}(4)}$ | 3,000 | 8,000 | 3,750 | 8,000 | 3,750 | 8,000 | 5,000 | 8,000 | ps | |
| | | CL = 3 | $t_{CK_{AVG}(3)}$ | – | – | 5,000 | 8,000 | 5,000 | 8,000 | 5,000 | 8,000 | ps | |
| | CK high-level width | $t_{CH_{AVG}}$ | 0.48 | 0.52 | 0.48 | 0.52 | 0.48 | 0.52 | 0.48 | 0.52 | t_{CK} | 45 | |
| | CK low-level width | $t_{CL_{AVG}}$ | 0.48 | 0.52 | 0.48 | 0.52 | 0.48 | 0.52 | 0.48 | 0.52 | t_{CK} | | |
| Half clock period | t_{HP} | MIN (t_{CH} , t_{CL}) | | MIN (t_{CH} , t_{CL}) | | MIN (t_{CH} , t_{CL}) | | MIN (t_{CH} , t_{CL}) | | MIN (t_{CH} , t_{CL}) | | ps | 46 |
| Clock (absolute) | Absolute t_{CK} | $t_{CK_{abs}}$ | $t_{CK_{AVG}}$ (MIN) + $t_{JIT_{PER}}$ (MIN) | $t_{CK_{AVG}}$ (MAX) + $t_{JIT_{PER}}$ (MAX) | $t_{CK_{AVG}}$ (MIN) + $t_{JIT_{PER}}$ (MIN) | $t_{CK_{AVG}}$ (MAX) + $t_{JIT_{PER}}$ (MAX) | $t_{CK_{AVG}}$ (MIN) + $t_{JIT_{PER}}$ (MIN) | $t_{CK_{AVG}}$ (MAX) + $t_{JIT_{PER}}$ (MAX) | $t_{CK_{AVG}}$ (MIN) + $t_{JIT_{PER}}$ (MIN) | $t_{CK_{AVG}}$ (MAX) + $t_{JIT_{PER}}$ (MAX) | ps | | |
| | Absolute CK high-level width | $t_{CH_{abs}}$ | $t_{CK_{AVG}}$ (MIN) * $t_{CH_{AVG}}$ (MIN) + $t_{JIT_{DTY}}$ (MIN) | $t_{CK_{AVG}}$ (MAX) * $t_{CH_{AVG}}$ (MAX) + $t_{JIT_{DTY}}$ (MAX) | $t_{CK_{AVG}}$ (MIN) * $t_{CH_{AVG}}$ (MIN) + $t_{JIT_{DTY}}$ (MIN) | $t_{CK_{AVG}}$ (MAX) * $t_{CH_{AVG}}$ (MAX) + $t_{JIT_{DTY}}$ (MAX) | $t_{CK_{AVG}}$ (MIN) * $t_{CH_{AVG}}$ (MIN) + $t_{JIT_{DTY}}$ (MIN) | $t_{CK_{AVG}}$ (MAX) * $t_{CH_{AVG}}$ (MAX) + $t_{JIT_{DTY}}$ (MAX) | $t_{CK_{AVG}}$ (MIN) * $t_{CH_{AVG}}$ (MIN) + $t_{JIT_{DTY}}$ (MIN) | $t_{CK_{AVG}}$ (MAX) * $t_{CH_{AVG}}$ (MAX) + $t_{JIT_{DTY}}$ (MAX) | ps | | |
| | Absolute CK low-level width | $t_{CL_{abs}}$ | $t_{CK_{AVG}}$ (MIN) * $t_{CL_{AVG}}$ (MIN) + $t_{JIT_{DTY}}$ (MIN) | $t_{CK_{AVG}}$ (MAX) * $t_{CL_{AVG}}$ (MAX) + $t_{JIT_{DTY}}$ (MAX) | $t_{CK_{AVG}}$ (MIN) * $t_{CL_{AVG}}$ (MIN) + $t_{JIT_{DTY}}$ (MIN) | $t_{CK_{AVG}}$ (MAX) * $t_{CL_{AVG}}$ (MAX) + $t_{JIT_{DTY}}$ (MAX) | $t_{CK_{AVG}}$ (MIN) * $t_{CL_{AVG}}$ (MIN) + $t_{JIT_{DTY}}$ (MIN) | $t_{CK_{AVG}}$ (MAX) * $t_{CL_{AVG}}$ (MAX) + $t_{JIT_{DTY}}$ (MAX) | $t_{CK_{AVG}}$ (MIN) * $t_{CL_{AVG}}$ (MIN) + $t_{JIT_{DTY}}$ (MIN) | $t_{CK_{AVG}}$ (MAX) * $t_{CL_{AVG}}$ (MAX) + $t_{JIT_{DTY}}$ (MAX) | ps | | |
| Clock Jitter | Clock jitter – period | $t_{JIT_{PER}}$ | –125 | 125 | –125 | 125 | –125 | 125 | –125 | 125 | ps | 39 | |
| | Clock jitter – half period | $t_{JIT_{DUTY}}$ | –125 | 125 | –125 | 125 | –125 | 125 | –150 | 150 | ps | 40 | |
| | Clock jitter – cycle to cycle | $t_{JIT_{CC}}$ | 250 | | 250 | | 250 | | 250 | | ps | 41 | |
| | Cumulative jitter error, 2 cycles | $t_{ERR_{2per}}$ | –175 | 175 | –175 | 175 | –175 | 175 | –175 | 175 | ps | 42 | |
| | Cumulative jitter error, 3 cycles | $t_{ERR_{3per}}$ | –225 | 225 | –225 | 225 | –225 | 225 | –225 | 225 | ps | 42 | |
| | Cumulative jitter error, 4 cycles | $t_{ERR_{4per}}$ | –250 | 250 | –250 | 250 | –250 | 250 | –250 | 250 | ps | 42 | |
| | Cumulative jitter error, 5 cycles | $t_{ERR_{5per}}$ | –250 | 250 | –250 | 250 | –250 | 250 | –250 | 250 | ps | 42, 48 | |
| | Cumulative jitter error, 6–10 cycles | $t_{ERR_{6-10per}}$ | –350 | 350 | –350 | 350 | –350 | 350 | –350 | 350 | ps | 42, 48 | |
| | Cumulative jitter error, 11–50 cycles | $t_{ERR_{11-50per}}$ | –450 | 450 | –450 | 450 | –450 | 450 | –450 | 450 | ps | 42 | |

Table 48: AC Operating Conditions for -3E, -3, -37E, and -5E Speeds (Sheet 2 of 6)

Notes: 1–5; notes appear on page 131; VDDQ = +1.8V ±0.1V, VDD = +1.8V ±0.1V

| AC Characteristics | | -3E | | -3 | | -37E | | -5E | | Units | Notes | |
|--------------------|---|-------------------|-------------------------------------|-----------------------|-------------------------------------|-----------------------|-------------------------------------|-----------------------|-------------------------------------|-----------------------|-----------------|------------|
| Parameter | Symbol | Min | Max | Min | Max | Min | Max | Min | Max | | | |
| Data | DQ hold skew factor | t _{QHS} | – | 340 | – | 340 | – | 400 | – | 450 | ps | 47 |
| | DQ output access time from CK/CK# | t _{AC} | –450 | +450 | –450 | +450 | –500 | +500 | –600 | +600 | ps | 34, 43 |
| | Data-out High-Z window from CK/CK# | t _{HZ} | | t _{AC} (MAX) | | t _{AC} (MAX) | | t _{AC} (MAX) | | t _{AC} (MAX) | ps | 8, 9, 43 |
| | DQS Low-Z window from CK/CK# | t _{LZ1} | t _{AC} (MIN) | t _{AC} (MAX) | t _{AC} (MIN) | t _{AC} (MAX) | t _{AC} (MIN) | t _{AC} (MAX) | t _{AC} (MIN) | t _{AC} (MAX) | ps | 8, 10, 43 |
| | DQ Low-Z window from CK/CK# | t _{LZ2} | 2 * t _{AC} (MIN) | t _{AC} (MAX) | 2 * t _{AC} (MIN) | t _{AC} (MAX) | 2 * t _{AC} (MIN) | t _{AC} (MAX) | 2 * t _{AC} (MIN) | t _{AC} (MAX) | ps | 8, 10, 43 |
| | DQ and DM input setup time relative to DQS | t _{DSa} | 300 | | 300 | | 350 | | 400 | | ps | 7, 15, 19 |
| | DQ and DM input hold time relative to DQS | t _{DHa} | 300 | | 300 | | 350 | | 400 | | ps | 7, 15, 19 |
| | DQ and DM input setup time relative to DQS | t _{DSb} | 100 | | 100 | | 100 | | 150 | | ps | 7, 15, 19 |
| | DQ and DM input hold time relative to DQS | t _{DHb} | 175 | | 175 | | 225 | | 275 | | ps | 7, 15, 19 |
| | DQ and DM input pulse width (for each input) | t _{DIPW} | 0.35 | | 0.35 | | 0.35 | | 0.35 | | t _{CK} | 37 |
| | Data hold skew factor | t _{QHS} | | 340 | | 340 | | 400 | | 450 | ps | 47 |
| | DQ–DQS hold, DQS to first DQ to go nonvalid, per access | t _{QH} | t _{HP} - t _{QHS} | | t _{HP} - t _{QHS} | | t _{HP} - t _{QHS} | | t _{HP} - t _{QHS} | | ps | 15, 17, 47 |
| | Data valid output window (DVW) | t _{DVW} | t _{QH} - t _{DQSQ} | | t _{QH} - t _{DQSQ} | | t _{QH} - t _{DQSQ} | | t _{QH} - t _{DQSQ} | | ns | 15, 17 |

Table 48: AC Operating Conditions for -3E, -3, -37E, and -5E Speeds (Sheet 3 of 6)

Notes: 1–5; notes appear on page 131; VDDQ = +1.8V ±0.1V, VDD = +1.8V ±0.1V

| AC Characteristics | | -3E | | -3 | | -37E | | -5E | | Units | Notes | |
|--------------------|--|--------------------|------------------------|------------------------|------------------------|------------------------|------------------------|------------------------|------------------------|------------------------|-----------------|----------------|
| Parameter | Symbol | Min | Max | Min | Max | Min | Max | Min | Max | | | |
| Data Strobe | DQS input-high pulse width | t _{DQSH} | 0.35 | | 0.35 | | 0.35 | | 0.35 | | t _{CK} | 37 |
| | DQS input-low pulse width | t _{DQSL} | 0.35 | | 0.35 | | 0.35 | | 0.35 | | t _{CK} | 37 |
| | DQS output access time from CK/CK# | t _{DQSCK} | -400 | +400 | -400 | +400 | -450 | +450 | -500 | +500 | ps | 34, 43 |
| | DQS falling edge to CK rising – setup time | t _{DSS} | 0.2 | | 0.2 | | 0.2 | | 0.2 | | t _{CK} | 37 |
| | DQS falling edge from CK rising – hold time | t _{DSH} | 0.2 | | 0.2 | | 0.2 | | 0.2 | | t _{CK} | 37 |
| | DQS–DQ skew, DQS to last DQ valid, per group, per access | t _{DQSQ} | | 240 | | 240 | | 300 | | 350 | ps | 15, 17 |
| | DQS read preamble | t _{RPRE} | 0.9 | 1.1 | 0.9 | 1.1 | 0.9 | 1.1 | 0.9 | 1.1 | t _{CK} | 33, 34, 37, 43 |
| | DQS read postamble | t _{RPST} | 0.4 | 0.6 | 0.4 | 0.6 | 0.4 | 0.6 | 0.4 | 0.6 | t _{CK} | 33, 34, 37, 43 |
| | Write preamble setup time | t _{WPRES} | 0 | | 0 | | 0 | | 0 | | ps | 12, 13 |
| | DQS write preamble | t _{WPRE} | 0.35 | | 0.35 | | 0.25 | | 0.25 | | t _{CK} | 37 |
| | DQS write postamble | t _{WPST} | 0.4 | 0.6 | 0.4 | 0.6 | 0.4 | 0.6 | 0.4 | 0.6 | t _{CK} | 11, 37 |
| | Positive DQS latching edge to associated clock edge | t _{DQSS} | -0.25 | 0.25 | -0.25 | 0.25 | -0.25 | 0.25 | -0.25 | 0.25 | t _{CK} | 37 |
| | WRITE command to first DQS latching transition | | WL - t _{DQSS} | WL + t _{DQSS} | WL - t _{DQSS} | WL + t _{DQSS} | WL - t _{DQSS} | WL + t _{DQSS} | WL - t _{DQSS} | WL + t _{DQSS} | t _{CK} | |

Table 48: AC Operating Conditions for -3E, -3, -37E, and -5E Speeds (Sheet 4 of 6)

Notes: 1-5; notes appear on page 131; VDDQ = +1.8V ±0.1V, VDD = +1.8V ±0.1V

| AC Characteristics | | | -3E | | -3 | | -37E | | -5E | | Units | Notes |
|---------------------|--|--------------------|-------------------|--------|-------------------|--------|-------------------|--------|-------------------|--------|----------|------------|
| Parameter | Symbol | Min | Max | Min | Max | Min | Max | Min | Max | | | |
| Command and Address | Address and control input pulse width for each input | t_{IPW} | 0.6 | | 0.6 | | 0.6 | | 0.6 | | t_{CK} | 37 |
| | Address and control input setup time | t_{ISa} | 400 | | 400 | | 500 | | 600 | | ps | 6, 19 |
| | Address and control input hold time | t_{IHa} | 400 | | 400 | | 500 | | 600 | | ps | 6, 19 |
| | Address and control input setup time | t_{ISb} | 200 | | 200 | | 250 | | 350 | | ps | 6, 19 |
| | Address and control input hold time | t_{IHb} | 275 | | 275 | | 375 | | 475 | | ps | 6, 19 |
| | CAS# to CAS# command delay | t_{CCD} | 2 | | 2 | | 2 | | 2 | | t_{CK} | 37 |
| | ACTIVE-to-ACTIVE (same bank) command | t_{RC} | 54 | | 55 | | 55 | | 55 | | ns | 31, 37 |
| | ACTIVE bank <i>a</i> to ACTIVE bank <i>b</i> command | t_{RRD} (x4, x8) | 7.5 | | 7.5 | | 7.5 | | 7.5 | | ns | 25, 37 |
| | | t_{RRD} (x16) | 10 | | 10 | | 10 | | 10 | | ns | 25, 37 |
| | ACTIVE-to-READ or WRITE delay | t_{RCD} | 12 | | 15 | | 15 | | 15 | | ns | 37 |
| | 4-Bank activate period | t_{FAW} (x4, x8) | 37.5 | | 37.5 | | 37.5 | | 37.5 | | ns | 28, 37 |
| | 4-Bank activate period | t_{FAW} (x16) | 50 | | 50 | | 50 | | 50 | | ns | 28, 37 |
| | ACTIVE-to-PRECHARGE command | t_{RAS} | 40 | 70,000 | 40 | 70,000 | 40 | 70,000 | 40 | 70,000 | ns | 18, 31, 37 |
| | Internal READ-to-PRECHARGE command delay | t_{RTP} | 7.5 | | 7.5 | | 7.5 | | 7.5 | | ns | 21, 25, 37 |
| | Write recovery time | t_{WR} | 15 | | 15 | | 15 | | 15 | | ns | 25, 37 |
| | Auto precharge write recovery + precharge time | t_{DAL} | $t_{WR} + t_{RP}$ | | $t_{WR} + t_{RP}$ | | $t_{WR} + t_{RP}$ | | $t_{WR} + t_{RP}$ | | ns | 20 |
| | Internal WRITE-to-READ command delay | t_{WTR} | 7.5 | | 7.5 | | 7.5 | | 10 | | ns | 25, 37 |
| | PRECHARGE command period | t_{RP} | 12 | | 15 | | 15 | | 15 | | ns | 29, 37 |
| | PRECHARGE ALL command period | t_{RPA} | $t_{RP} + t_{CK}$ | | $t_{RP} + t_{CK}$ | | $t_{RP} + t_{CK}$ | | $t_{RP} + t_{CK}$ | | ns | 29 |
| | LOAD MODE command cycle time | t_{MRD} | 2 | | 2 | | 2 | | 2 | | t_{CK} | 37 |

Table 48: AC Operating Conditions for -3E, -3, -37E, and -5E Speeds (Sheet 5 of 6)

Notes: 1–5; notes appear on page 131; VDDQ = +1.8V ±0.1V, VDD = +1.8V ±0.1V

| AC Characteristics | | -3E | | -3 | | -37E | | -5E | | Units | Notes | |
|--------------------|--|-------------------------------|---|--|---|--|---|--|---|--|-----------------|--------|
| Parameter | Symbol | Min | Max | Min | Max | Min | Max | Min | Max | | | |
| Refresh | CKE LOW to CK, CK# uncertainty | t_{DELAY} | $t_{\text{IS}} + t_{\text{CK}} + t_{\text{IH}}$ | | $t_{\text{IS}} + t_{\text{CK}} + t_{\text{IH}}$ | | $t_{\text{IS}} + t_{\text{CK}} + t_{\text{IH}}$ | | $t_{\text{IS}} + t_{\text{CK}} + t_{\text{IH}}$ | | ns | 26 |
| | REFRESH-to-ACTIVE or REFRESH-to-REFRESH command interval | t_{RFC} | 127.5 | 70,000 | 127.5 | 70,000 | 127.5 | 70,000 | 127.5 | 70,000 | ns | 14, 37 |
| | Average periodic refresh interval (commercial) | t_{REFI} | | 7.8 | | 7.8 | | 7.8 | | 7.8 | μs | 14, 37 |
| | Average periodic refresh interval (industrial) | $t_{\text{REFI}_{\text{IT}}}$ | | 3.9 | | 3.9 | | 3.9 | | 3.9 | μs | 14, 37 |
| Self Refresh | Exit SELF REFRESH to non-READ command | t_{XSNR} | t_{RFC} (MIN) + 10 | | t_{RFC} (MIN) + 10 | | t_{RFC} (MIN) + 10 | | t_{RFC} (MIN) + 10 | | ns | |
| | Exit SELF REFRESH to READ command | t_{XSRD} | 200 | | 200 | | 200 | | 200 | | t_{CK} | 37 |
| | Exit SELF REFRESH timing reference | t_{ISXR} | t_{IS} | | t_{IS} | | t_{IS} | | t_{IS} | | ps | 6, 27 |
| ODT | ODT turn-on delay | t_{AOND} | 2 | 2 | 2 | 2 | 2 | 2 | 2 | 2 | t_{CK} | 37 |
| | ODT turn-on | t_{AON} | t_{AC} (MIN) | t_{AC} (MAX) + 700 | t_{AC} (MIN) | t_{AC} (MAX) + 700 | t_{AC} (MIN) | t_{AC} (MAX) + 1,000 | t_{AC} (MIN) | t_{AC} (MAX) + 1000 | ps | 23, 43 |
| | ODT turn-off delay | t_{AOFD} | 2.5 | 2.5 | 2.5 | 2.5 | 2.5 | 2.5 | 2.5 | 2.5 | t_{CK} | 35, 37 |
| | ODT turn-off | t_{AOF} | t_{AC} (MIN) | t_{AC} (MAX) + 600 | t_{AC} (MIN) | t_{AC} (MAX) + 600 | t_{AC} (MIN) | t_{AC} (MAX) + 600 | t_{AC} (MIN) | t_{AC} (MAX) + 600 | ps | 24, 44 |
| | ODT turn-on (power-down mode) | t_{AONPD} | t_{AC} (MIN) + 2,000 | $2 \times t_{\text{CK}} + t_{\text{AC}}$ (MAX) + 1,000 | t_{AC} (MIN) + 2,000 | $2 \times t_{\text{CK}} + t_{\text{AC}}$ (MAX) + 1,000 | t_{AC} (MIN) + 2000 | $2 \times t_{\text{CK}} + t_{\text{AC}}$ (MAX) + 1,000 | t_{AC} (MIN) + 2,000 | $2 \times t_{\text{CK}} + t_{\text{AC}}$ (MAX) + 1000 | ps | |
| | ODT turn-off (power-down mode) | t_{AOFPD} | t_{AC} (MIN) + 2,000 | $2.5 \times t_{\text{CK}} + t_{\text{AC}}$ (MAX) + 1,000 | t_{AC} (MIN) + 2,000 | $2.5 \times t_{\text{CK}} + t_{\text{AC}}$ (MAX) + 1,000 | t_{AC} (MIN) + 2,000 | $2.5 \times t_{\text{CK}} + t_{\text{AC}}$ (MAX) + 1,000 | t_{AC} (MIN) + 2,000 | $2.5 \times t_{\text{CK}} + t_{\text{AC}}$ (MAX) + 1,000 | ps | |
| | ODT to power-down entry latency | t_{ANPD} | 3 | | 3 | | 3 | | 3 | | t_{CK} | 37 |
| | ODT power-down exit latency | t_{AXPD} | 8 | | 8 | | 8 | | 8 | | t_{CK} | 37 |
| | ODT enable from MRS command | t_{MOD} | 12 | | 12 | | 12 | | 12 | | ns | 37, 49 |

Table 48: AC Operating Conditions for -3E, -3, -37E, and -5E Speeds (Sheet 6 of 6)

Notes: 1–5; notes appear on page 131; VDDQ = +1.8V ±0.1V, VDD = +1.8V ±0.1V

| AC Characteristics | | -3E | | -3 | | -37E | | -5E | | Units | Notes | |
|--------------------|--|--------------------|--------|-----|--------|------|--------|-----|--------|-------|-----------------|--------|
| Parameter | Symbol | Min | Max | Min | Max | Min | Max | Min | Max | | | |
| Power-Down | Exit active power-down to READ command, MR[12] = 0 | t _{XARD} | 2 | | 2 | | 2 | | 2 | | t _{CK} | 37 |
| | Exit active power-down to READ command, MR[12] = 1 | t _{XARDS} | 7 - AL | | 7 - AL | | 6 - AL | | 6 - AL | | t _{CK} | 37 |
| | Exit precharge power-down to any non-READ command | t _{XP} | 2 | | 2 | | 2 | | 2 | | t _{CK} | 37 |
| | CKE MIN HIGH/LOW time | t _{CKE} | 3 | | 3 | | 3 | | 3 | | t _{CK} | 32, 37 |

Table 49: AC Operating Conditions for -25E and -25 Speeds (Sheet 1 of 4)

Notes: 1–5; notes appear on page 131; VDDQ = +1.8V ±0.1V, VDD = +1.8V ±0.1V

| AC Characteristics | | | -25E | | -25 | | Units | Notes | |
|---------------------------------------|--------------------------------------|---------------------|--|--|--|--|----------|--------|----------------|
| Parameter | Symbol | Min | Max | Min | Max | | | | |
| Clock | Clock cycle time | CL = 6 | $t_{CK_{AVG}(6)}$ | – | – | 2,500 | 8,000 | ps | 16, 22, 36, 38 |
| | | CL = 5 | $t_{CK_{AVG}(5)}$ | 2,500 | 8,000 | 3,000 | 8,000 | ps | |
| | | CL = 4 | $t_{CK_{AVG}(4)}$ | 3,750 | 8,000 | N/A | N/A | ps | |
| | CK high-level width | $t_{CH_{AVG}}$ | 0.48 | 0.52 | 0.48 | 0.52 | t_{CK} | 45 | |
| | CK low-level width | $t_{CL_{AVG}}$ | 0.48 | 0.52 | 0.48 | 0.52 | t_{CK} | 45 | |
| | Half-clock period | t_{HP} | MIN (t_{CH} , t_{CL}) | | MIN (t_{CH} , t_{CL}) | | ps | 46 | |
| | Absolute t_{CK} | $t_{CK_{abs}}$ | $t_{CK_{AVG}(MIN)} + t_{JIT_{PER}(MIN)}$ | $t_{CK_{AVG}(MAX)} + t_{JIT_{PER}(MAX)}$ | $t_{CK_{AVG}(MIN)} + t_{JIT_{PER}(MIN)}$ | $t_{CK_{AVG}(MAX)} + t_{JIT_{PER}(MAX)}$ | ps | | |
| | Absolute CK high-level width | $t_{CH_{ABS}}$ | $t_{CK_{AVG}(MIN)} * t_{CH_{AVG}(MIN)} + t_{JIT_{DTY}(MIN)}$ | $t_{CK_{AVG}(MAX)} * t_{CH_{AVG}(MAX)} + t_{JIT_{DTY}(MAX)}$ | $t_{CK_{AVG}(MIN)} * t_{CH_{AVG}(MIN)} + t_{JIT_{DTY}(MIN)}$ | $t_{CK_{AVG}(MAX)} * t_{CH_{AVG}(MAX)} + t_{JIT_{DTY}(MAX)}$ | ps | | |
| | Absolute CK low-level width | $t_{CL_{ABS}}$ | $t_{CK_{AVG}(MIN)} * t_{CL_{AVG}(MIN)} + t_{JIT_{DTY}(MIN)}$ | $t_{CK_{AVG}(MAX)} * t_{CL_{AVG}(MAX)} + t_{JIT_{DTY}(MAX)}$ | $t_{CK_{AVG}(MIN)} * t_{CL_{AVG}(MIN)} + t_{JIT_{DTY}(MIN)}$ | $t_{CK_{AVG}(MAX)} * t_{CL_{AVG}(MAX)} + t_{JIT_{DTY}(MAX)}$ | ps | | |
| Clock Jitter | Clock jitter – period | $t_{JIT_{PER}}$ | –100 | 100 | –100 | 100 | ps | 39 | |
| | Clock jitter – half period | $t_{JIT_{DUTY}}$ | –100 | 100 | –100 | 100 | ps | 40 | |
| | Clock jitter – cycle to cycle | $t_{JIT_{CC}}$ | 200 | | 200 | | ps | 41 | |
| | Cumulative jitter error, 2 cycles | $t_{ERR_{2per}}$ | –150 | 150 | –150 | 150 | ps | 42 | |
| | Cumulative jitter error, 3 cycles | $t_{ERR_{3per}}$ | –175 | 175 | –175 | 175 | ps | 42 | |
| | Cumulative jitter error, 4 cycles | $t_{ERR_{4per}}$ | –200 | 200 | –200 | 200 | ps | 42 | |
| | Cumulative jitter error, 5 cycles | $t_{ERR_{5per}}$ | –200 | 200 | –200 | 200 | ps | 42, 48 | |
| | Cumulative jitter error, 6–10 cycles | $t_{ERR_{6-10per}}$ | –300 | 300 | –300 | 300 | ps | 42, 48 | |
| Cumulative jitter error, 11–50 cycles | $t_{ERR_{11-50per}}$ | –450 | 450 | –450 | 450 | ps | 42 | | |

Table 49: AC Operating Conditions for -25E and -25 Speeds (Sheet 2 of 4)

Notes: 1–5; notes appear on page 131; VDDQ = +1.8V ±0.1V, VDD = +1.8V ±0.1V

| AC Characteristics | | | -25E | | -25 | | Units | Notes |
|--------------------|--|-------------|---------------------|-----------------|---------------------|-----------------|----------|----------------|
| Parameter | Symbol | Min | Max | Min | Max | | | |
| Data | DQ output access time from CK/CK# | t_{AC} | -400 | +400 | -400 | +400 | ps | 34, 43 |
| | Data-out High-Z window from CK/CK# | t_{HZ} | | $t_{AC} (MAX)$ | | $t_{AC} (MAX)$ | ps | 8, 9, 43 |
| | DQS Low-Z window from CK/CK# | t_{LZ1} | $t_{AC} (MIN)$ | $t_{AC} (MAX)$ | $t_{AC} (MIN)$ | $t_{AC} (MAX)$ | ps | 8, 10, 43 |
| | DQ Low-Z window from CK/CK# | t_{LZ2} | $2 * t_{AC} (MIN)$ | $t_{AC} (MAX)$ | $2 * t_{AC} (MIN)$ | $t_{AC} (MAX)$ | ps | 8, 10, 43 |
| | DQ and DM input setup time relative to DQS | t_{DSa} | 250 | | 250 | | ps | 15, 19 |
| | DQ and DM input hold time relative to DQS | t_{DH_a} | 250 | | 250 | | ps | 15, 19 |
| | DQ and DM input setup time relative to DQS | t_{DSb} | 50 | | 50 | | ps | 15, 19 |
| | DQ and DM input hold time relative to DQS | t_{DH_b} | 125 | | 125 | | ps | 15, 19 |
| | DQ and DM input pulse width (for each input) | t_{DIPW} | 0.35 | | 0.35 | | t_{CK} | 37 |
| | Data hold skew factor | t_{QHS} | | 300 | | 300 | ps | 47 |
| | DQ–DQS hold from DQS | t_{QH} | $t_{HP} - t_{QHS}$ | | $t_{HP} - t_{QHS}$ | | ps | 15, 17, 47 |
| | Data valid output window (DVW) | t_{DVW} | $t_{QH} - t_{DQSQ}$ | | $t_{QH} - t_{DQSQ}$ | | ns | 15, 17 |
| Data Strobe | DQS input-high pulse width | t_{DQSH} | 0.35 | | 0.35 | | t_{CK} | 37 |
| | DQS input-low pulse width | t_{DQSL} | 0.35 | | 0.35 | | t_{CK} | 37 |
| | DQS output access time from CK/CK# | t_{DQSCK} | -350 | +350 | -350 | +350 | ps | 34, 43 |
| | DQS falling edge to CK rising – setup time | t_{DSS} | 0.2 | | 0.2 | | t_{CK} | 37 |
| | DQS falling edge from CK rising – hold time | t_{DSH} | 0.2 | | 0.2 | | t_{CK} | 37 |
| | DQS–DQ skew, DQS to last DQ valid, per group, per access | t_{DQSQ} | | 200 | | 200 | ps | 15, 17 |
| | DQS read preamble | t_{RPRE} | 0.9 | 1.1 | 0.9 | 1.1 | t_{CK} | 33, 34, 37, 43 |
| | DQS read postamble | t_{RPST} | 0.4 | 0.6 | 0.4 | 0.6 | t_{CK} | 33, 34, 37, 43 |
| | Write preamble setup time | t_{WPRES} | 0 | | 0 | | ps | 12, 13 |
| | DQS write preamble | t_{WPRE} | 0.35 | | 0.35 | | t_{CK} | 37 |
| | DQS write postamble | t_{WPST} | 0.4 | 0.6 | 0.4 | 0.6 | t_{CK} | 11, 37 |
| | Positive DQS latching edge to associated clock edge | t_{DQSS} | -0.25 | +0.25 | -0.25 | +0.25 | t_{CK} | 37 |
| | WRITE command to first DQS latching transition | | $WL - t_{DQSS}$ | $WL + t_{DQSS}$ | $WL - t_{DQSS}$ | $WL + t_{DQSS}$ | t_{CK} | |



Table 49: AC Operating Conditions for -25E and -25 Speeds (Sheet 3 of 4)

Notes: 1–5; notes appear on page 131; VDDQ = +1.8V ±0.1V, VDD = +1.8V ±0.1V

| AC Characteristics | | -25E | | -25 | | Units | Notes |
|------------------------------|--|------------------------|----------------------------|-------------------|----------------------------|-------------|----------------|
| Parameter | Symbol | Min | Max | Min | Max | | |
| Command and Address | Address and control input pulse width for each input | t_{IPW} | 0.6 | | 0.6 | | t_{CK} 37 |
| | Address and control input setup time | t_{IS_a} | 375 | | 375 | | ps 19 |
| | Address and control input hold time | t_{IH_a} | 375 | | 375 | | ps 19 |
| | Address and control input setup time | t_{IS_b} | 175 | | 175 | | ps 19 |
| | Address and control input hold time | t_{IH_b} | 250 | | 250 | | ps 19 |
| | CAS# to CAS# command delay | t_{CCD} | 2 | | 2 | | t_{CK} 37 |
| | ACTIVE-to-ACTIVE (same bank) command | t_{RC} | 55 | | 55 | | ns 31, 37 |
| | ACTIVE bank a to ACTIVE bank b command | t_{RRD} (x4, x8) | 7.5 | | 7.5 | | ns 25, 37 |
| | | t_{RRD} (x16) | 10 | | 10 | | ns 25, 37 |
| | ACTIVE-to-READ or WRITE delay | t_{RCD} | 12.5 | | 15 | | ns 37 |
| | 4-bank activate period | t_{FAW} (1K page) | 37.5 | | 37.5 | | ns 28, 37 |
| | 4-bank activate period | t_{FAW} (2K page) | 50 | | 50 | | ns 28, 37 |
| | ACTIVE-to-PRECHARGE command | t_{RAS} | 45 | 70,000 | 45 | 70,000 | ns 18, 31, 37 |
| | Internal READ-to-PRECHARGE command delay | t_{RTP} | 7.5 | | 7.5 | | ns 21, 25, 37 |
| | Write recovery time | t_{WR} | 15 | | 15 | | ns 25, 37 |
| | Auto precharge write recovery + precharge time | t_{DAL} | $t_{WR} + t_{RP}$ | | $t_{WR} + t_{RP}$ | | ns 20 |
| | Internal WRITE-to-READ command delay | t_{WTR} | 7.5 | | 10 | | ns 25, 37 |
| | PRECHARGE command period | t_{RP} | 12.5 | | 15 | | ns 29, 37 |
| PRECHARGE ALL command period | t_{RPA} | $t_{RP} + t_{CK}$ | | $t_{RP} + t_{CK}$ | | ns 29 | |
| LOAD MODE command cycle time | t_{MRD} | 2 | | 2 | | t_{CK} 37 | |
| Refresh | CKE low to CK, CK# uncertainty | t_{DELAY} | $t_{IS} + t_{CK} + t_{IH}$ | | $t_{IS} + t_{CK} + t_{IH}$ | | ns 26 |
| | REFRESH-to-ACTIVE or REFRESH-to-REFRESH command interval | t_{RFC} | 127.5 | 70,000 | 127.5 | 70,000 | ns 14, 37 |
| | Average periodic refresh interval | t_{REFI} | | 7.8 | | 7.8 | μs 14, 37 |
| | Average periodic refresh interval (industrial) | $t_{REFI_{IT}}$ | | 3.9 | | 3.9 | μs 14, 37 |
| Self Refresh | Exit self refresh to non-READ command | t_{XSNR} | t_{RFC} (MIN) + 10 | | t_{RFC} (MIN) + 10 | | ns |
| | Exit self refresh to READ command | t_{XSRD} | 200 | | 200 | | t_{CK} 37 |
| | Exit self refresh timing reference | t_{ISXR} | t_{IS} | | t_{IS} | | ps 6, 27 |

Table 49: AC Operating Conditions for -25E and -25 Speeds (Sheet 4 of 4)

Notes: 1–5; notes appear on page 131; VDDQ = +1.8V ±0.1V, VDD = +1.8V ±0.1V

| AC Characteristics | | -25E | | -25 | | Units | Notes | |
|--------------------|--|--------------|------------------------|--|------------------------|--|----------|--------|
| Parameter | Symbol | Min | Max | Min | Max | | | |
| ODT | ODT turn-on delay | t_{AOND} | 2 | 2 | 2 | 2 | t_{CK} | 37 |
| | ODT turn-on | t_{AON} | $t_{AC} (MIN)$ | $t_{AC} (MAX) + 700$ | $t_{AC} (MIN)$ | $t_{AC} (MAX) + 700$ | ps | 23, 43 |
| | ODT turn-off delay | t_{AOFD} | 2.5 | 2.5 | 2.5 | 2.5 | t_{CK} | 35, 37 |
| | ODT turn-off | t_{AOF} | $t_{AC} (MIN)$ | $t_{AC} (MAX) + 600$ | $t_{AC} (MIN)$ | $t_{AC} (MAX) + 600$ | ps | 24, 44 |
| | ODT turn-on (power-down mode) | t_{AONPD} | $t_{AC} (MIN) + 2,000$ | $2 \times t_{CK} + t_{AC} (MAX) + 1,000$ | $t_{AC} (MIN) + 2,000$ | $2 \times t_{CK} + t_{AC} (MAX) + 1,000$ | ps | |
| | ODT turn-off (power-down mode) | t_{AOFDPD} | $t_{AC} (MIN) + 2,000$ | $2.5 \times t_{CK} + t_{AC} (MAX) + 1,000$ | $t_{AC} (MIN) + 2,000$ | $2.5 \times t_{CK} + t_{AC} (MAX) + 1,000$ | ps | |
| | ODT to power-down entry latency | t_{ANPD} | 3 | | 3 | | t_{CK} | 37 |
| | ODT power-down exit latency | t_{AXPD} | 10 | | 10 | | t_{CK} | 37 |
| | ODT enable from MRS command | t_{MOD} | 12 | | 12 | | ns | 37, 49 |
| Power-Down | Exit active power-down to READ command, MR[12] = 0 | t_{XARD} | 2 | | 2 | | t_{CK} | 37 |
| | Exit active power-down to READ command, MR[12] = 1 | t_{XARDS} | 8 - AL | | 8 - AL | | t_{CK} | 37 |
| | Exit precharge power-down to any non-READ command | t_{XP} | 2 | | 2 | | t_{CK} | 37 |
| | CKE MIN HIGH/LOW time | t_{CKE} | 3 | | 3 | | t_{CK} | 32, 37 |

Notes

1. All voltages are referenced to Vss.
2. Tests for AC timing, IDD, and electrical AC and DC characteristics may be conducted at nominal reference/supply voltage levels, but the related specifications and device operation are guaranteed for the full voltage range specified. ODT is disabled for all measurements that are not ODT-specific.
3. Outputs measured with equivalent load:

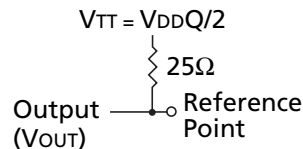

4. AC timing and IDD tests may use a V_{IL}-to-V_{IH} swing of up to 1.0V in the test environment and parameter specifications are guaranteed for the specified AC input levels under normal use conditions. The slew rate for the input signals used to test the device is 1.0 V/ns for signals in the range between V_{IL(AC)} and V_{IH(AC)}. Slew rates other than 1.0 V/ns may require the timing parameters to be derated as specified.
5. The AC and DC input level specifications are as defined in the SSTL_18 standard (i.e., the receiver will effectively switch as a result of the signal crossing the AC input level and will remain in that state as long as the signal does not ring back above [below] the DC input LOW [HIGH] level).
6. There are two sets of values listed for Command/Address: ^tIS_a, ^tIH_a and ^tIS_b, ^tIH_b. The ^tIS_a, ^tIH_a values (for reference only) are equivalent to the baseline values of ^tIS_b, ^tIH_b at V_{REF} when the slew rate is 1 V/ns. The baseline values, ^tIS_b, ^tIH_b, are the JEDEC-defined values, referenced from the logic trip points. ^tIS_b is referenced from V_{IH(AC)} for a rising signal and V_{IL(AC)} for a falling signal, while ^tIH_b is referenced from V_{IL(DC)} for a rising signal and V_{IH(DC)} for a falling signal. If the Command/Address slew rate is not equal to 1 V/ns, then the baseline values must be derated by adding the values from Tables 26 and 27 on page 94.
7. The values listed are for the differential DQS strobe (DQS and DQS#) with a differential slew rate of 2 V/ns (1 V/ns for each signal). There are two sets of values listed: ^tDS_a, ^tDH_a and ^tDS_b, ^tDH_b. The ^tDS_a, ^tDH_a values (for reference only) are equivalent to the baseline values of ^tDS_b, ^tDH_b at V_{REF} when the slew rate is 2 V/ns, differentially. The baseline values, ^tDS_b, ^tDH_b, are the JEDEC-defined values, referenced from the logic trip points. ^tDS_b is referenced from V_{IH(AC)} for a rising signal and V_{IL(AC)} for a falling signal, while ^tDH_b is referenced from V_{IL(DC)} for a rising signal and V_{IH(DC)} for a falling signal. If the differential DQS slew rate is not equal to 2 V/ns, then the baseline values must be derated by adding the values from Tables 28 and 29 on pages 99–100. If the DQS differential strobe feature is not enabled, then the DQS strobe is single-ended, the baseline values not applicable, and timing is not referenced to the logic trip points. Single-ended DQS data timing is referenced to DQS crossing V_{REF}. The correct timing values for a single-ended DQS strobe are listed in Tables 30–33 on pages 101–102; listed values are already derated for slew rate variations and can be used directly from the table.
8. ^tHZ and ^tLZ transitions occur in the same access time windows as valid data transitions. These parameters are not referenced to a specific voltage level, but specify when the device output is no longer driving (^tHZ) or begins driving (^tLZ).
9. This maximum value is derived from the referenced test load. ^tHZ (MAX) will prevail over ^tDQSCK (MAX) + ^tRPST (MAX) condition.
10. ^tLZ (MIN) will prevail over a ^tDQSCK (MIN) + ^tRPRE (MAX) condition.

11. The intent of the “Don’t Care” state after completion of the postamble is that the DQS-driven signal should either be HIGH, LOW, or High-Z, and that any signal transition within the input switching region must follow valid input requirements. That is, if DQS transitions HIGH (above $V_{IH[DC]}$ MIN), then it must not transition LOW (below $V_{IH[DC]}$) prior to t_{DQSH} (MIN).
12. This is not a device limit. The device will operate with a negative value, but system performance could be degraded due to bus turnaround.
13. It is recommended that DQS be valid (HIGH or LOW) on or before the WRITE command. The case shown (DQS going from High-Z to logic LOW) applies when no WRITES were previously in progress on the bus. If a previous WRITE was in progress, DQS could be HIGH during this time, depending on t_{DQSS} .
14. The refresh period is 64ms (commercial) or 32ms (industrial). This equates to an average refresh rate of 7.8125 μ s (commercial) or 3.9607 μ s (industrial). However, a REFRESH command must be asserted at least once every 70.3 μ s or t_{RFC} (MAX). To ensure all rows of all banks are properly refreshed, 8,192 REFRESH commands must be issued every 64ms (commercial) or 32ms (industrial).
15. Referenced to each output group: x4 = DQS with DQ0–DQ3; x8 = DQS with DQ0–DQ7; x16 = LDQS with DQ0–DQ7; and UDQS with DQ8–DQ15.
16. CK and CK# input slew rate is referenced at 1 V/ns (2 V/ns if measured differentially).
17. The data valid window is derived by achieving other specifications: t_{HP} ($t_{CK}/2$), t_{DQSQ} , and t_{QH} ($t_{QH} = t_{HP} - t_{QHS}$). The data valid window derates in direct proportion to the clock duty cycle and a practical data valid window can be derived.
18. READs and WRITEs with auto precharge *are* allowed to be issued before t_{RAS} (MIN) is satisfied since t_{RAS} lockout feature is supported in DDR2 SDRAM.
19. V_{IL}/V_{IH} DDR2 overshoot/undershoot. See “AC Overshoot/Undershoot Specification” on page 110.
20. $t_{DAL} = (nWR) + (t_{RP}/t_{CK})$. Each of these terms, if not already an integer, should be rounded up to the next integer. t_{CK} refers to the application clock period; nWR refers to the t_{WR} parameter stored in the MR[11, 10, 9]. For example, -37E at $t_{CK} = 3.75$ ns with t_{WR} programmed to four clocks would have $t_{DAL} = 4 + (15\text{ns}/3.75\text{ns})$ clocks = 4 + (4) clocks = 8 clocks.
21. The minimum internal READ to PRECHARGE time. This is the time from the last 4-bit prefetch begins to when the PRECHARGE command can be issued. A 4-bit prefetch is when the READ command internally latches the READ so that data will output CL later. This parameter is only applicable when $t_{RTP} / (2 \times t_{CK}) > 1$, such as frequencies faster than 533 MHz when $t_{RTP} = 7.5$ ns. If $t_{RTP} / (2 \times t_{CK}) \leq 1$, then equation AL + BL/2 applies. t_{RAS} (MIN) also has to be satisfied as well. The DDR2 SDRAM will automatically delay the internal PRECHARGE command until t_{RAS} (MIN) has been satisfied.
22. Operating frequency is only allowed to change during self refresh mode (see Figure 58 on page 76), precharge power-down mode, or system reset condition (See “Reset Function” on page 77). SSC allows for small deviations in operating frequency, provided the SSC guidelines are satisfied.
23. ODT turn-on time t_{AON} (MIN) is when the device leaves High-Z and ODT resistance begins to turn on. ODT turn-on time t_{AON} (MAX) is when the ODT resistance is fully on. Both are measured from t_{AOND} .
24. ODT turn-off time t_{AOF} (MIN) is when the device starts to turn off ODT resistance. ODT turn off time t_{AOF} (MAX) is when the bus is in High-Z. Both are measured from t_{AOFD} .
25. This parameter has a two clock minimum requirement at any t_{CK} .

26. t^{DELAY} is calculated from $t^{\text{IS}} + t^{\text{CK}} + t^{\text{IH}}$ so that CKE registration LOW is guaranteed prior to CK, CK# being removed in a system RESET condition. See "Reset Function" on page 77.
27. t^{ISXR} is equal to t^{IS} and is used for CKE setup time during self refresh exit, as shown in Figure 47 on page 67.
28. No more than four bank-ACTIVE commands may be issued in a given t^{FAW} (MIN) period. t^{RRD} (MIN) restriction still applies. The t^{FAW} (MIN) parameter applies to all 8-bank DDR2 devices, regardless of the number of banks already open or closed.
29. t^{RPA} timing applies when the PRECHARGE (ALL) command is issued, regardless of the number of banks already open or closed. If a single-bank PRECHARGE command is issued, t^{RP} timing applies. t^{RPA} (MIN) applies to all 8-bank DDR2 devices.
30. N/A.
31. This is applicable to READ cycles only. WRITE cycles generally require additional time due to t^{WR} during auto precharge.
32. t^{CKE} (MIN) of three clocks means CKE must be registered on three consecutive positive clock edges. CKE must remain at the valid input level the entire time it takes to achieve the three clocks of registration. Thus, after any CKE transition, CKE may not transition from its valid level during the time period of $t^{\text{IS}} + 2 \times t^{\text{CK}} + t^{\text{IH}}$.
33. This parameter is not referenced to a specific voltage level, but specified when the device output is no longer driving (t^{RPST}) or beginning to drive (t^{RPRE}).
34. When DQS is used single-ended, the minimum limit is reduced by 100ps.
35. The half-clock of t^{AOFD} 's $2.5 t^{\text{CK}}$ assumes a 50/50 clock duty cycle. This half-clock value must be derated by the amount of half-clock duty cycle error. For example, if the clock duty cycle was 47/53, t^{AOFD} would actually be $2.5 - 0.03$, or 2.47, for t^{AOF} (MIN) and $2.5 + 0.03$, or 2.53, for t^{AOF} (MAX).
36. The clock's $t^{\text{CK}_{\text{AVG}}}$ is the average clock over any 200 consecutive clocks and $t^{\text{CK}_{\text{AVG}}}$ (MIN) is the smallest clock rate allowed, except a deviation due to allowed clock jitter. Input clock jitter is allowed provided it does not exceed values specified. Also, the jitter must be of a random Gaussian distribution in nature.
37. The inputs to the DRAM must be aligned to the associated clock; that is, the actual clock that latches it in. However, the input timing (in ns) references to the $t^{\text{CK}_{\text{AVG}}}$ when determining the required number of clocks. The following input parameters are determined by taking the specified percentage times the $t^{\text{CK}_{\text{AVG}}}$ rather than t^{CK} : t^{IPW} , t^{DIPW} , t^{DQSS} , t^{DQSH} , t^{DQSL} , t^{DSS} , t^{DSH} , t^{WPST} , and t^{WPRE} .
38. Spread spectrum is not included in the jitter specification values. However, the input clock can accommodate spread spectrum at a sweep rate in the range 20–60 KHz with additional one percent of $t^{\text{CK}_{\text{AVG}}}$ as a long-term jitter component; however, the spread spectrum may not use a clock rate below $t^{\text{CK}_{\text{AVG}}(\text{MIN})}$ or above $t^{\text{CK}_{\text{AVG}}(\text{MAX})}$.
39. The period jitter ($t^{\text{JIT}}_{\text{PER}}$) is the maximum deviation in the clock period from the average or nominal clock allowed in either the positive or negative direction. JEDEC specifies tighter jitter numbers during DLL locking time. During DLL lock time, the jitter values should be 20 percent less than noted in the table (DLL locked).
40. The half-period jitter ($t^{\text{JIT}}_{\text{DTY}}$) applies to either the high pulse of clock or the low pulse of clock; however, the two cumulatively can not exceed $t^{\text{JIT}}_{\text{PER}}$.
41. The cycle-to-cycle jitter ($t^{\text{JIT}}_{\text{CC}}$) is the amount the clock period can deviate from one cycle to the following cycle. JEDEC specifies tighter jitter numbers during DLL locking time. During DLL lock time, the jitter values should be 20 percent less than noted in the table (DLL locked).
42. The cumulative jitter error ($t^{\text{ERR}}_{\text{nPER}}$), where n is 2, 3, 4, 5, 6–10, or 11–50, is the amount of clock time allowed to consecutively accumulate away from the average clock over any number of clock cycles.

43. The DRAM output timing is aligned to the nominal or average clock. Most output parameters must be derated by the actual jitter error when input clock jitter is present; this will result in each parameter becoming larger. The following parameters are required to be derated by subtracting $t_{ERR_{5PER}}^{(MAX)}$: $t_{AC}^{(MIN)}$, $t_{DQSCK}^{(MIN)}$, $t_{LZ_{DQS}}^{(MIN)}$, $t_{LZ_{DQ}}^{(MIN)}$, $t_{AON}^{(MIN)}$; while these following parameters are required to be derated by subtracting $t_{ERR_{5PER}}^{(MIN)}$: $t_{AC}^{(MAX)}$, $t_{DQSCK}^{(MAX)}$, $t_{HZ}^{(MAX)}$, $t_{LZ_{DQS}}^{(MAX)}$, $t_{LZ_{DQ}}^{(MAX)}$, $t_{AON}^{(MAX)}$. The parameter $t_{RPRE}^{(MIN)}$ is derated by subtracting $t_{JIT_{PER}}^{(MAX)}$, while $t_{RPRE}^{(MAX)}$, is derated by subtracting $t_{JIT_{PER}}^{(MIN)}$. The parameter $t_{RPST}^{(MIN)}$ is derated by subtracting $t_{JIT_{DTY}}^{(MAX)}$, while $t_{RPST}^{(MAX)}$, is derated by subtracting $t_{JIT_{DTY}}^{(MIN)}$.
44. Half-clock output parameters must be derated by the actual $t_{ERR_{5PER}}$ and $t_{JIT_{DTY}}$ when input clock jitter is present; this will result in each parameter becoming larger. The parameter $t_{AOF}^{(MIN)}$ is required to be derated by subtracting both $t_{ERR_{5PER}}^{(MAX)}$ and $t_{JIT_{DTY}}^{(MAX)}$. The parameter $t_{AOF}^{(MAX)}$ is required to be derated by subtracting both $t_{ERR_{5PER}}^{(MIN)}$ and $t_{JIT_{DTY}}^{(MIN)}$.
45. $\text{MIN}(t_{CL}, t_{CH})$ refers to the smaller of the actual clock LOW time and the actual clock HIGH time driven to the device. The clock's half period must also be of a Gaussian distribution; $t_{CH_{AVG}}$ and $t_{CL_{AVG}}$ must be met with or without clock jitter and with or without duty cycle jitter. $t_{CH_{AVG}}$ and $t_{CL_{AVG}}$ are the average of any 200 consecutive CK falling edges.
46. $t_{HP}^{(MIN)}$ is the lesser of t_{CL} and t_{CH} actually applied to the device CK and CK# inputs; thus, $t_{HP}^{(MIN)} \geq$ the lesser of $t_{CL_{ABS}}^{(MIN)}$ and $t_{CH_{ABS}}^{(MIN)}$.
47. $t_{QH} = t_{HP} - t_{QHS}$; the worst case t_{QH} would be the smaller of $t_{CL_{ABS}}^{(MAX)}$ or $t_{CH_{ABS}}^{(MAX)}$ times $t_{CK_{ABS}}^{(MIN)} - t_{QHS}$. Minimizing the amount of $t_{CH_{AVG}}$ offset and value of $t_{JIT_{DTY}}$ will provide a larger t_{QH} , which in turn will provide a larger valid data out window.
48. JEDEC specifies using $t_{ERR_{6-10PER}}$ when derating clock-related output timing (notes 43–44). Micron requires less derating by allowing $t_{ERR_{5PER}}$ to be used.
49. Requires 8 t_{CK} for backward compatibility.

Package Dimensions

Figure 92: 84-Ball FBGA Package – 10mm x 16.5mm (x16)

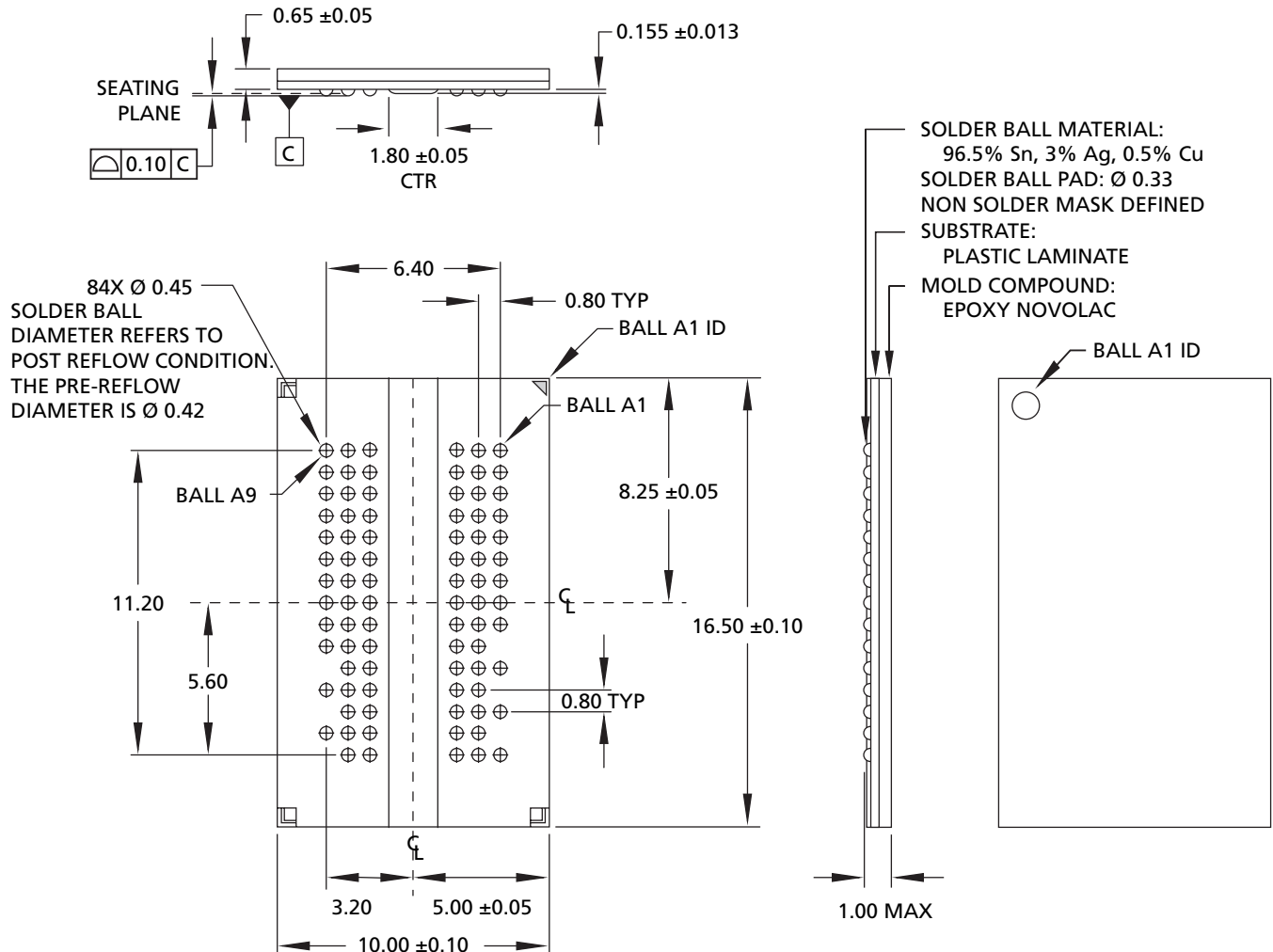

Note: All dimensions are in millimeters.

Figure 93: 68-Ball FBGA Package – 10mm x 16.5mm (x4/x8)

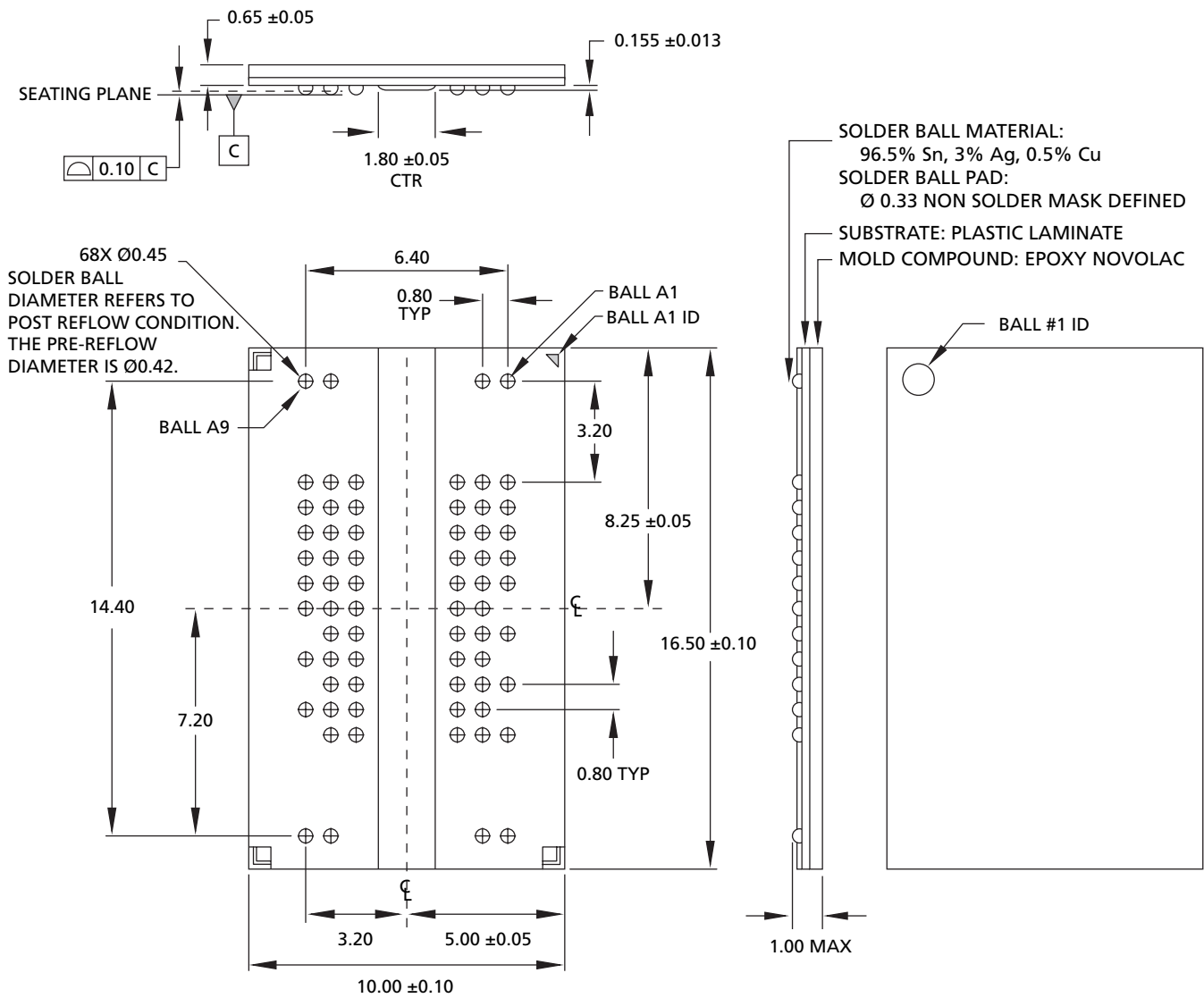

Note: All dimensions are in millimeters.

Figure 94: 92-Ball FBGA Package – 11mm x 19mm (x4/x8/x16)

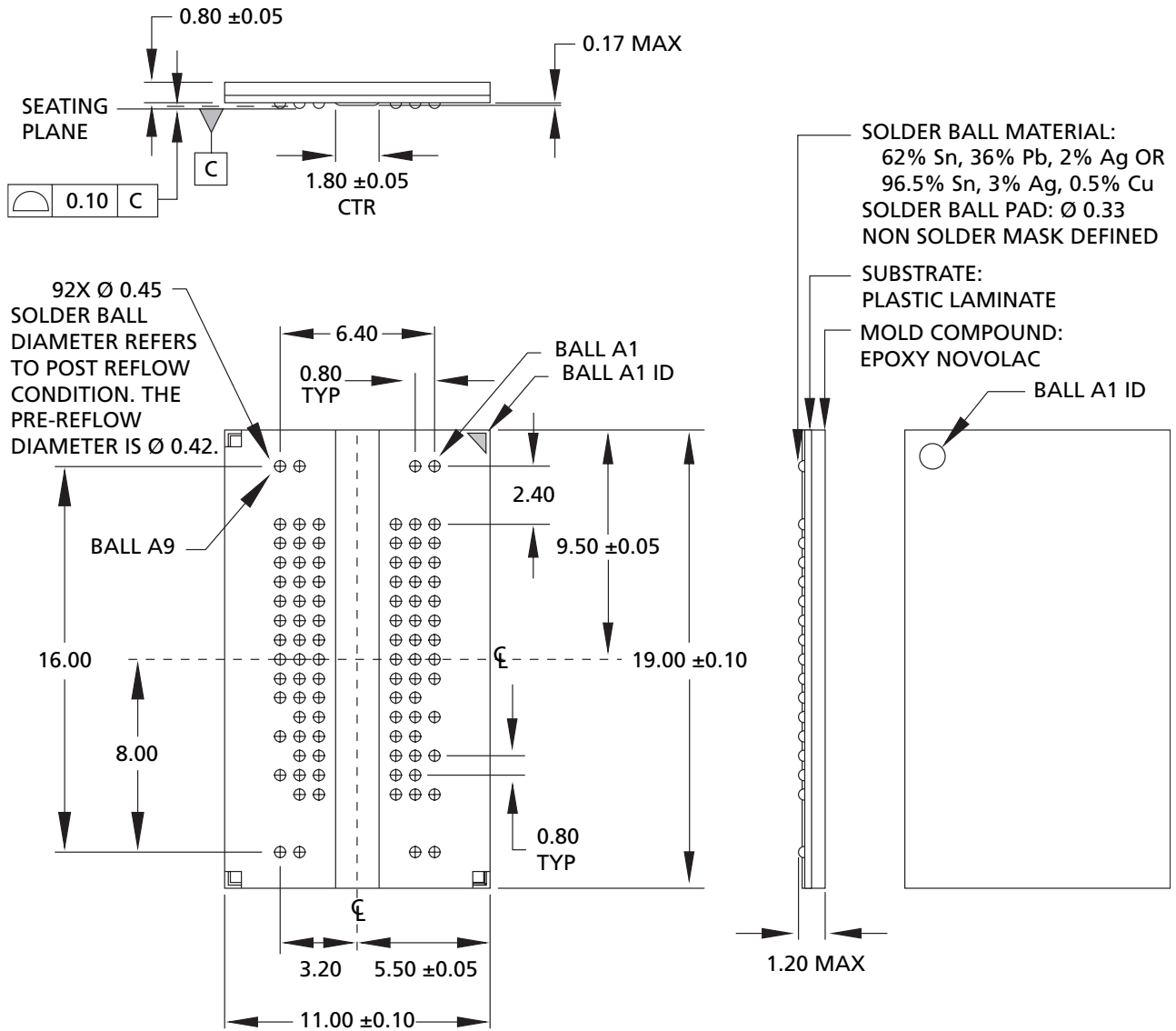

Note: All dimensions are in millimeters.



8000 S. Federal Way, P.O. Box 6, Boise, ID 83707-0006, Tel: 208-368-3900



prodmarkt@micron.com www.micron.com Customer Comment Line: 800-932-4992

Micron, the M logo, and the Micron logo are trademarks of Micron Technology, Inc. All other trademarks are the property of their respective owners.







This data sheet contains minimum and maximum limits specified over the complete power supply and temperature range for production devices. Although considered final, these specifications are subject to change, as further product development and data characterization sometimes occur.

Looking for pricing, stock, or lifecycle information?

Click below to explore more details on WIN SOURCE:

-  [View MT47H64M16BT-5E:A on WIN SOURCE](#)
-  [Micron Technology Inc. Information](#)

Optimize Your Supply Chain with WIN SOURCE Solutions

-  Global Sourcing Solution
-  Obsolete Management
-  Cost Control Management
-  Shortage Management
-  Alternative Solution
-  Excess Inventory Management