



THE DATASHEET OF MSMLJ10CAE3



MSMLG5.0A – MSMLG170CAe3, MSMLJ5.0A – MSMLJ170CAe3 Surface Mount 3000 Watt Transient Voltage Suppressor

1 Product Overview

The MSMLG5.0A–MSMLG170CA and the MSMLJ5.0A–MSMLJ170CA series of high-reliability transient voltage suppressors (TVS) protect circuits from voltage spikes containing up to 3000 W (10/1000 μ s model pulse). The SMLG gull-wing design in the DO-215AB package allows for visible solder connections. The SMLJ J-bend design in the DO-214AB package allows for greater PC board mounting density. Selections include unidirectional and bidirectional as well as RoHS-compliant versions. These are available with a variety of upscreening options for enhanced reliability. They protect against the secondary effects of lightning per IEC61000-4-5 and against voltage pulses from inductive switching environments and induced by RF radiation. Since their response time is virtually instantaneous, they can also be used in protection from ESD and EFT per IEC61000-4-2 and IEC61000-4-4.

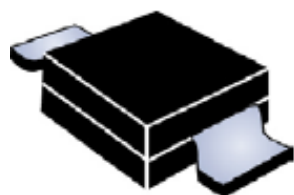

**DO-215AB
Package**



**DO-214AB
Package**

For the latest information, visit our website www.microsemi.com.

1.1 Features

The following are key features of the MSMLG5.0A through MSMLG170CAe3 and the MSMLJ5.0A through MSMLJ170CAe3 devices:

- High-reliability devices with fabrication and assembly lot traceability for all M prefix devices
- All devices are 100% surge tested
- 3σ lot norm screening performed on standby current (I_b) for all M prefix devices
- Available in both unidirectional and bidirectional versions
- Moisture classification is “Level 1” with no dry pack required per IPC/JEDEC J-STD-020B for all M prefix devices.
- Enhanced reliability screening options with M prefix are available in reference to MIL-PRF-19500. Refer to [High Reliability Up-Screened Plastic Products Portfolio](#) for more details on the screening options (see Part Nomenclature for all available options).
- RoHS compliant versions available
- Axial-lead equivalent packages for thru-hole mounting are available as M5KP5.0A to M5KP110CA with 5000 W rating (contact Microsemi for other surface mount options).

1.2 Applications and Benefits

The following are benefits of the MSMLG5.0A through MSMLG170CAe3 and the MSMLJ5.0A through MSMLJ170CAe3 devices.

- Suppresses transients up to 3000 W (10/1000 μ s test pulse—see [Figure 2 \(see page 7\)](#))
- Protection from switching transients and induced RF
- Protection from ESD, and EFT per IEC 61000-4-2 and IEC 61000-4-4
- Secondary lightning protection per IEC 61000-4-5 with 42 Ω source impedance:

Class 1 and 2: SML 5.0A to SML 170A or CA

Class 3: SML 5.0A to SML 150A or CA

Class 4: SML 5.0A to SML 75A or CA

- Secondary lightning protection per IEC 61000-4-5 with 12 Ω source impedance:

Class 1: SML 5.0A to SML 170A or CA

Class 2: SML 5.0A to SML 90A or CA

Class 3: SML 5.0A to SML 48A or CA

Class 4: SML 5.0A to SML 24A or CA

- Secondary lightning protection per IEC 61000-4-5 with 2 Ω source impedance:

Class 2: SML 5.0A to SML 43A or CA

Class 3: SML 5.0A to SML 22A or CA

Class 4: SML 5.0A to SML10A or CA

1.3 Part Nomenclature

The following table lists the part nomenclature for the MSMLG5.0A through MSMLG170CAe3 and the MSMLJ5.0 through MSMLJ170CAe3 devices.

Table 1 • MXSMLG5.0CAe3 Part Nomenclature

MX	Reliability level*	M (controlled product) MA (avionics grade) MX (reference JANTX) MXL (MX life) Blank = commercial *(see Hirel Non-Hermetic Product Portfolio)
SM	Surface-mount package	
L	3000 W power level	
G or J	Gull-wing or J-bend lead frame	
5.0	Reverse standoff voltage	(see Typical Electrical Performance (see page 5) table)
C	Uni/bidirectional	C = Bidirectional Blank = Unidirectional
A	± 5% Tolerance level	
e3	RoHS Compliance	e3 = RoHS compliant Blank = non-RoHS compliant

1.4 Symbols and Definitions

The following table lists the symbols and definitions used for the MSMLG5.0A through MSMLG170CAe3 and the MSMLJ5.0 through MSMLJ170CAe3 devices.

Table 2 • Symbols and Definitions

Symbol	Value	Definition
$I_{(BR)}$	Breakdown current	The current used for measuring breakdown voltage $V_{(BR)}$.
I_D	Standby current	The current at the rated standoff voltage V_{WM} .
I_F	Forward current	The forward current dc value, no alternating component.
I_{PP}	Peak impulse current	The peak current during the impulse.
P_{PP}	Peak pulse Power	The peak power dissipation resulting from peak impulse current I_{PP} .
$V_{(BR)}$	Minimum breakdown voltage	The minimum voltage the device will exhibit at a specified current.
V_C	Clamping voltage	Clamping voltage at I_{PP} (peak pulse current) at the specified pulse conditions (typically shown as maximum value).
V_{WM}	Rated working standoff voltage	The maximum peak voltage that can be applied over the operating temperature range.

2 Electrical Specifications

This section shows the electrical specifications for the MSMLG5.0A–MSMLG170CA and the MSMLJ5.0A–MSMLJ170CA devices.

2.1 Maximum Ratings

The following table shows you the absolute maximum ratings for the MSMLG5.0A–MSMLG170CA and the MSMLJ5.0A–MSMLJ170CA devices.

Table 3 • Absolute Maximum Ratings

Parameter/Test Conditions	Symbol	Value	Unit
Junction and storage temperature	T_J and T_{STG}	–65 to 150	°C
Thermal resistance junction-to-lead	$R_{\theta JL}$	17.5	°C/W
Thermal resistance junction-to-ambient ¹	$R_{\theta JA}$	77.5	
Peak pulse power dissipation at 25 °C (10/1000 μ s, see Figures 1, 2, and 3).	P_{PP}	3000	W
Impulse repetition rate (duty factor)	df	0.01 or less	%
$t_{clamping}$ (0 V to $V_{(BR)}$ min)	Unidirectional	$t_{clamping}$	<100 ps
	Bidirectional		<5 ns
Rated average power dissipation	TL = 45 °C	$P_{M(AV)}$	6 W
	TL = 25 °C		1.61 ¹
Maximum forward surge current ²	I_{FSM}	200	A (pk)
Solder temperature at 10 s	T_{SP}	260	°C

Notes:

1. When mounted on FR4 PC board (1 oz Cu) with recommended mounting pad (see pad layout).
2. Peak impulse of 8.3 ms half-sine wave at 25 °C (unidirectional only).

2.2 Typical Electrical Performance

The following table shows the Electrical characteristics for the MSMLG5.0A–MSMLG170CA and the MSMLJ5.05A–MSMLJ170CA devices at 25 °C unless otherwise specified.

For bidirectional device types, indicate a CA suffix after the part number (i.e. MSMLG170CA).

Table 4 • Typical Electrical Performance

Part Number		V _{WM} Reverse Standoff Voltage	V _{BR} Breakdown Voltage at I _{BR}	I _{BR} Test Current	V _c Max Clamping Voltage at I _{PP}	I _{PP} Max Peak Pulse Current	I _D Max Stand-by Current at V _{WM}
Gull-wing	J-bend	(V)	(V)	(mA)	(V)	(A)	(μA)
SMLG5.0A	SMLJ5.0A	5.0	6.40 – 7.00	10	9.2	326.0	1000
SMLG6.0A	SMLJ6.0A	6.0	6.67 – 7.37	10	10.3	291.3	1000
SMLG6.5A	SMLJ6.5A	6.5	7.22 – 7.98	10	11.2	267.9	500
SMLG7.0A	SMLJ7.0A	7.0	7.78 – 8.60	10	12.0	250.0	200
SMLG7.5A	SMLJ7.5A	7.5	8.33 – 9.21	1	12.9	232.6	100
SMLG8.0A	SMLJ8.0A	8.0	8.89 – 9.83	1	13.6	220.6	50
SMLG8.5A	SMLJ8.5A	8.5	9.44 – 10.4	1	14.4	208.4	25
SMLG9.0A	SMLJ9.0A	9.0	10.0 – 11.1	1	15.4	194.8	10
SMLG10A	SMLJ10A	10	11.1 – 12.3	1	17.0	176.4	5
SMLG11A	SMLJ11A	11	12.2 – 13.5	1	18.2	164.8	5
SMLG12A	SMLJ12A	12	13.3 – 14.7	1	19.9	150.6	5
SMLG13A	SMLJ13A	13	14.4 – 15.9	1	21.5	139.4	5
SMLG14A	SMLJ14A	14	15.6 – 17.2	1	23.2	129.4	2
SMLG15A	SMLJ15A	15	16.7 – 18.5	1	24.4	123.0	2
SMLG16A	SMLJ16A	16	17.8 – 19.7	1	26.0	115.4	2
SMLG17A	SMLJ17A	17	18.9 – 20.9	1	27.6	106.6	2
SMLG18A	SMLJ18A	18	20.0 – 22.1	1	29.2	102.8	2
SMLG20A	SMLJ20A	20	22.2 – 24.5	1	32.4	92.6	2
SMLG22A	SMLJ22A	22	24.4 – 26.9	1	35.5	84.4	2
SMLG24A	SMLJ24A	24	26.7 – 29.5	1	38.9	77.2	2
SMLG26A	SMLJ26A	26	28.9 – 31.9	1	42.1	71.2	2
SMLG28A	SMLJ28A	28	31.1 – 34.4	1	45.4	66.0	2
SMLG30A	SMLJ30A	30	33.3 – 36.8	1	48.4	62.0	2
SMLG33A	SMLJ33A	33	36.7 – 40.6	1	53.3	56.2	2
SMLG36A	SMLJ36A	36	40.0 – 44.2	1	58.1	51.6	2
SMLG40A	SMLJ40A	40	44.4 – 49.1	1	64.5	46.4	2
SMLG43A	SMLJ43A	43	47.8 – 52.8	1	69.4	43.2	2
SMLG45A	SMLJ45A	45	50.0 – 55.3	1	72.7	41.2	2
SMLG48A	SMLJ48A	48	53.3 – 58.9	1	77.4	38.8	2
SMLG51A	SMLJ51A	51	56.7 – 62.7	1	82.4	36.4	2
SMLG54A	SMLJ54A	54	60.0 – 66.3	1	87.1	34.4	2
SMLG58A	SMLJ58A	58	64.4 – 71.2	1	93.6	32.0	2
SMLG60A	SMLJ60A	60	66.7 – 73.7	1	96.8	31.0	2
SMLG64A	SMLJ64A	64	71.1 – 78.6	1	103.0	29.2	2
SMLG70A	SMLJ70A	70	77.8 – 86.0	1	113	26.6	2
SMLG75A	SMLJ75A	75	83.3 – 92.1	1	121	24.8	2

Part Number		V _{WM} Reverse Standoff Voltage	V _{BR} Breakdown Voltage at I _{BR}	I _{BR} Test Current	V _c Max Clamping Voltage at I _{PP}	I _{PP} Max Peak Pulse Current	I _b Max Stand-by Current at V _{WM}
SMLG78A	SMLJ78A	78	86.7 – 95.8	1	126	22.8	2
SMLG85A	SMLJ85A	85	94.4 – 104.0	1	137	20.8	2
SMLG90A	SMLJ90A	90	100 – 111	1	146	20.6	2
SMLG100A	SMLJ100A	100	111 – 123	1	162	18.6	2
SMLG110A	SMLJ110A	110	122 – 135	1	177	16.8	2
SMLG120A	SMLJ120A	120	133 – 147	1	193	15.6	2
SMLG130A	SMLJ130A	130	144 – 159	1	209	14.4	2
SMLG150A	SMLJ150A	150	167 – 185	1	243	12.4	2
SMLG160A	SMLJ160A	160	178 – 197	1	259	11.6	2
SMLG170A	SMLJ170A	170	189 – 209	1	275	11.0	2

Bidirectional capacitance is half that shown in [Figure 4](#) (see page 8) at 0 V.

2.3 Typical Performance Curves

This section shows the typical performance curves of the MSMLG5.0A–MSMLG170CA and the MSMLJ5.0A–MSMLJ170CA devices.

The following graph shows peak-pulse power versus pulse time (up to 50% of exponentially decaying pulse).

Figure 1 • Peak Pulse Power vs. Pulse Time (to 50% of exponentially decaying pulse)

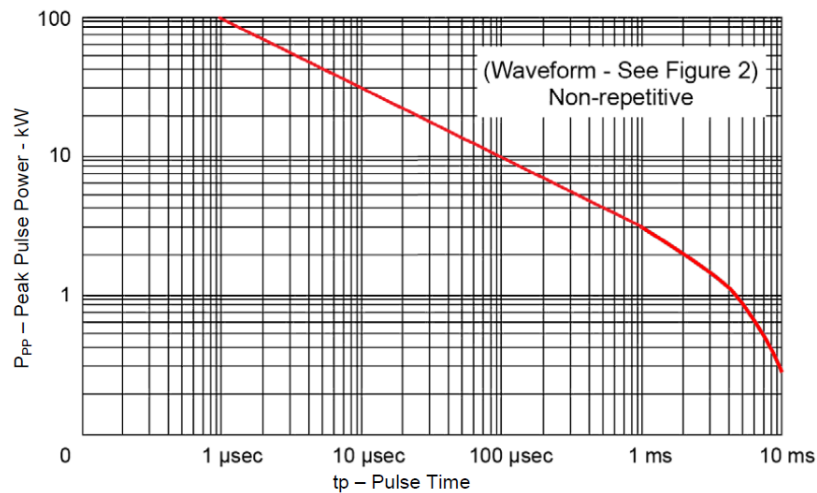

The following graph shows the pulse waveform with these parameters: $t_r = 10 \mu s$ and $t_p = 1000 \mu s$.

Figure 2 • Pulse Waveform

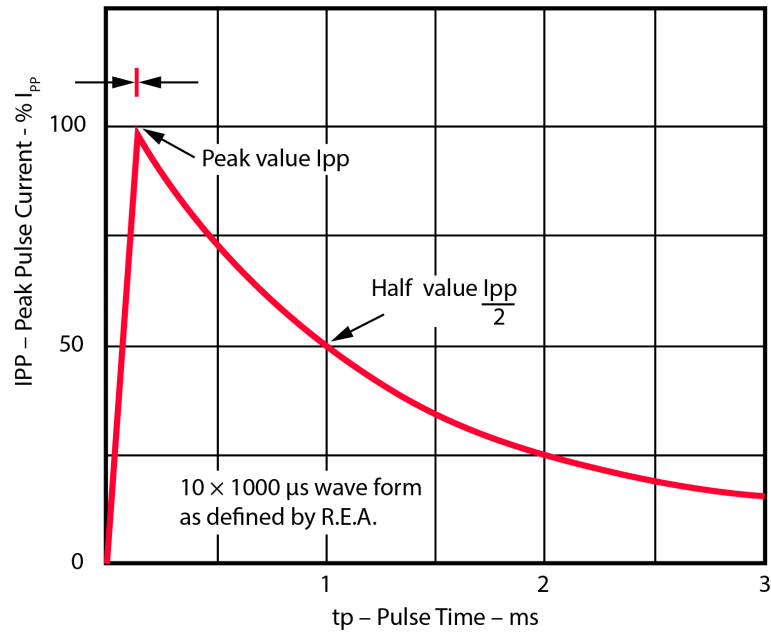

The following graph shows the derating curve.

Figure 3 • Derating Curve

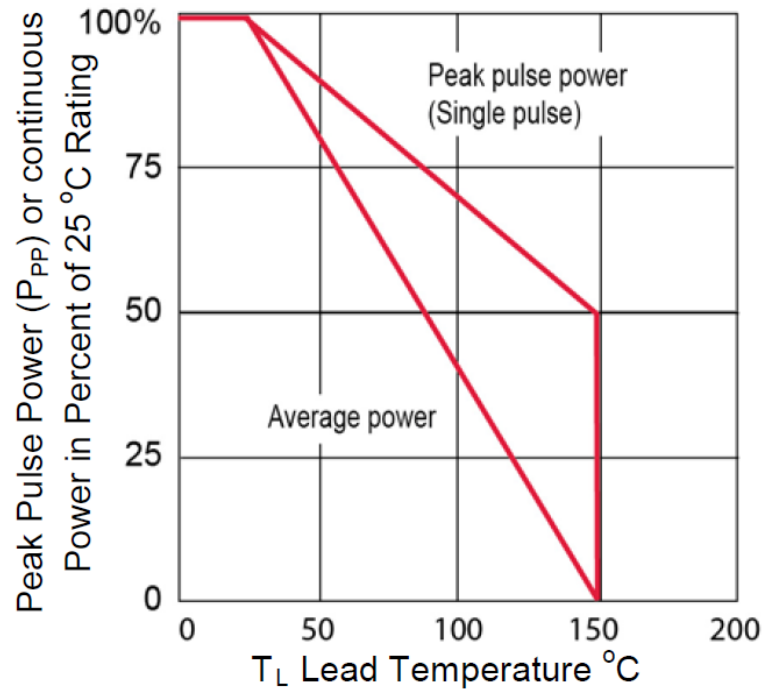

The following graph shows the typical capacitance versus the breakdown voltage. Note that the bidirectional capacitance is half that shown at 0 V.

Figure 4 • Typical Capacitance vs. Breakdown Voltage (Unidirectional Configuration)

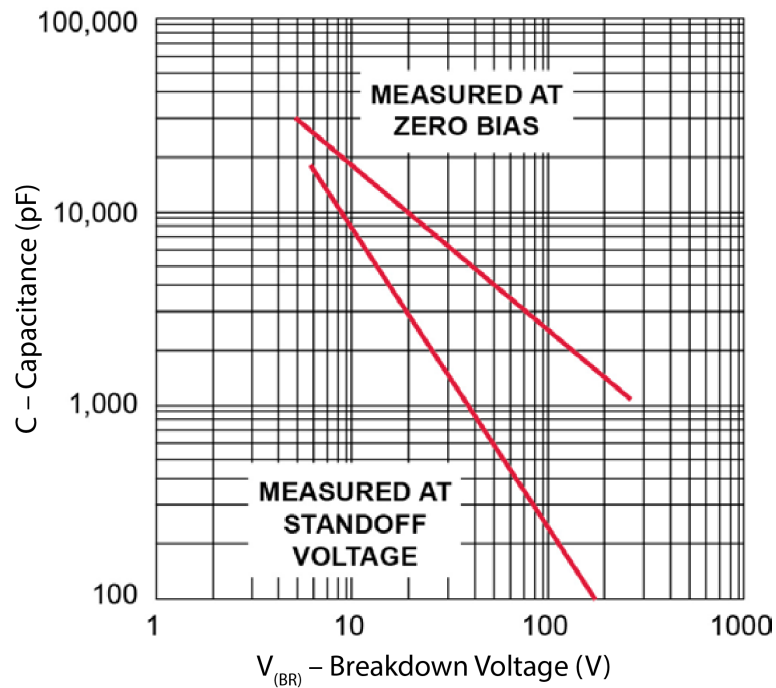

Note:

Bidirectional capacitance is half that shown in Figure 4 at 0 V.

3 Package Specification

The following sections shows the package specifications for the SMLG (DO-215AB) and SMLG (DO-214AB) packages.

3.1 Package Information

The following illustration shows the SMLJ DO-214AB package dimensions. The typical standoff height is 0.004 in—0.008 in (0.1—0.2 mm).

Figure 5 • SMLG (DO-215AB) Package Dimensions

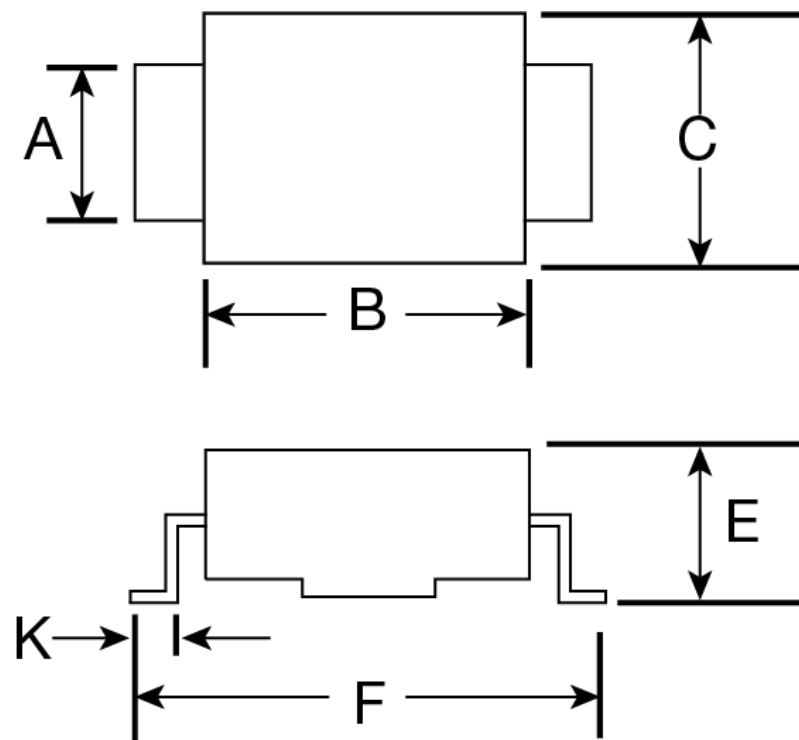

The following table shows the SMLG DO-215AB mechanical and packaging information.

Table 5 • SMLG (DO-215AB) Mechanical and Package Information

Letter	Dimensions (in.)	Dimensions (mm)
A	0.115—0.121	2.92—3.07
B	0.260—0.280	6.60—7.11
C	0.220—0.245	5.59—6.22
E	0.077—0.110	1.95—2.80
F ¹	0.380—0.400	9.65—10.16
K	0.025—0.040	0.635—1.016

Note:

1. Dimension "E" exceeds the JEDEC outline as shown.

The following illustration shows the mechanical and packaging information for the SMLG (DO-214AB) package.

Figure 6 • SMLJ_(DO-214AB)_Package_Dimensions

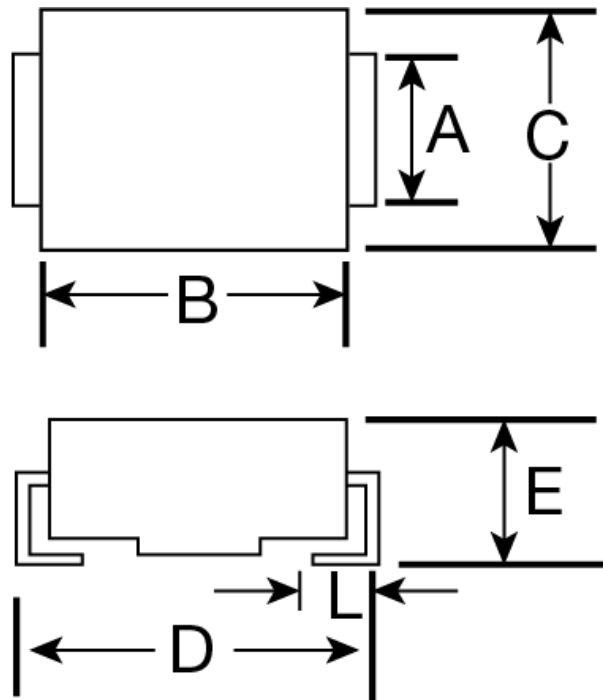

The following table shows the SMLJ DO-214AB mechanical and packaging information.

Table 6 • SMLJ (DO-214AB) Mechanical and Package Information

Letter	Dimensions (in.)	Dimensions (mm)
A	0.115–0.121	2.92–3.07
B	0.260–0.280	6.60–7.11
C	0.220–0.245	5.59–6.22
D	0.305–0.320	7.75–8.13
E	0.077–0.110	1.95–2.80
L	0.030–0.060	0.760–1.52

3.2 Pad Layout

The following illustration shows the pad layout for the SMLG (DO-215AB) and SMLJ (DO-214AB) packages.

Figure 7 • Pad Layout

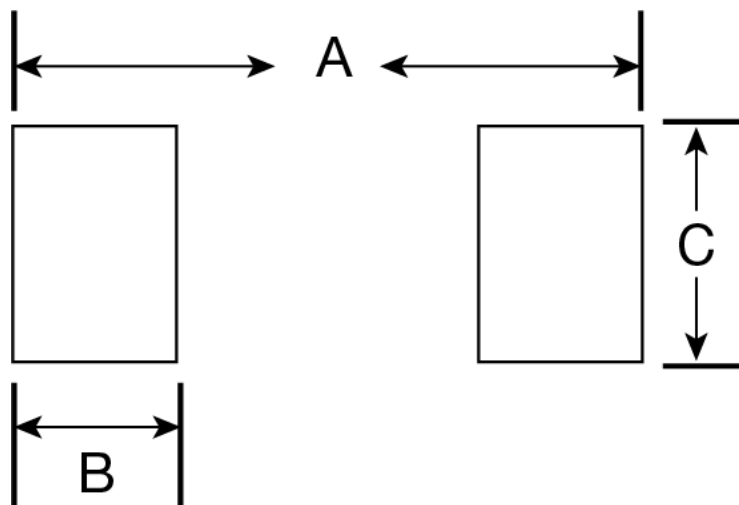

The following table shows the SMLG DO-215AB pad layout dimensions.

Table 7 • SMLG (DO-215AB) Pad Layout Dimensions

Letter	Dimensions (in.)	Dimensions (mm)
A	0.510	12.95
B	0.110	2.79
C	0.150	3.81

The following table shows the SMLJ DO-214AB pad layout dimensions.

Table 8 • SMLJ (DO-214AB) Pad Layout Dimensions

Letter	Dimensions (in.)	Dimensions (mm)
A	0.390	9.90
B	0.110	2.79
C	0.150	3.81



Microsemi Headquarters

One Enterprise, Aliso Viejo,
CA 92656 USA

Within the USA: +1 (800) 713-4113

Outside the USA: +1 (949) 380-6100

Sales: +1 (949) 380-6136

Fax: +1 (949) 215-4996

Email: sales.support@microsemi.com

www.microsemi.com

© 2018 Microsemi. All rights reserved. Microsemi and the Microsemi logo are trademarks of Microsemi Corporation. All other trademarks and service marks are the property of their respective owners.

Microsemi makes no warranty, representation, or guarantee regarding the information contained herein or the suitability of its products and services for any particular purpose, nor does Microsemi assume any liability whatsoever arising out of the application or use of any product or circuit. The products sold hereunder and any other products sold by Microsemi have been subject to limited testing and should not be used in conjunction with mission-critical equipment or applications. Any performance specifications are believed to be reliable but are not verified, and Buyer must conduct and complete all performance and other testing of the products, alone and together with, or installed in, any end-products. Buyer shall not rely on any data and performance specifications or parameters provided by Microsemi. It is the Buyer's responsibility to independently determine suitability of any products and to test and verify the same. The information provided by Microsemi hereunder is provided "as is, where is" and with all faults, and the entire risk associated with such information is entirely with the Buyer. Microsemi does not grant, explicitly or implicitly, to any party any patent rights, licenses, or any other IP rights, whether with regard to such information itself or anything described by such information. Information provided in this document is proprietary to Microsemi, and Microsemi reserves the right to make any changes to the information in this document or to any products and services at any time without notice.

Microsemi, a wholly owned subsidiary of Microchip Technology Inc. (Nasdaq: MCHP), offers a comprehensive portfolio of semiconductor and system solutions for aerospace & defense, communications, data center and industrial markets. Products include high-performance and radiation-hardened analog mixed-signal integrated circuits, FPGAs, SoCs and ASICs; power management products; timing and synchronization devices and precise time solutions, setting the world's standard for time; voice processing devices; RF solutions; discrete components; enterprise storage and communication solutions; security technologies and scalable anti-tamper products; Ethernet solutions; Power-over-Ethernet ICs and midspans; as well as custom design capabilities and services. Microsemi is headquartered in Aliso Viejo, California, and has approximately 4,800 employees globally. Learn more at www.microsemi.com.

RF01003

Looking for pricing, stock, or lifecycle information?

Click below to explore more details on WIN SOURCE:

- ⊖ [View MSMLJ10CAE3 on WIN SOURCE](#)
- ⊖ [Microchip Technology Information](#)

Optimize Your Supply Chain with WIN SOURCE Solutions

- ✓ Global Sourcing Solution
- ✓ Obsolete Management
- ✓ Cost Control Management
- ✓ Shortage Management
- ✓ Alternative Solution
- ✓ Excess Inventory Management