



**THE DATASHEET OF
MPQ2483ADQ-AEC1-LF-Z**





The Future of Analog IC Technology®

MPQ2483A

Industrial/Automotive-Grade
55V, 2.5A Programmable
Frequency LED Driver
Available in AEC-Q100

DESCRIPTION

The MPQ2483A is a 55V LED driver suitable for either step-down or inverting step-up and step-down applications. It achieves a 2.5A peak current with excellent load and line regulation over a wide input supply range.

The MPQ2483A incorporates both DC and PWM dimming into a single control pin. The separate input reference ground allows for direct enable and dimming control for positive-to-negative power conversion.

Current-mode operation provides fast transient response and eases loop stabilization. Full protection features include cycle-by-cycle peak current limiting, output over-voltage protection (OVP), open-string protection, output short-circuit protection (SCP), and thermal shutdown.

The MPQ2483A requires a minimal number of readily available, standard, external components and is available in 10-pin QFN (3mmx3mm) and 14-pin SOIC14 packages.

FEATURES

- 2.5A Maximum Peak Current
- Buck or Buck-Boost Modes
- Wide 4.5V to 55V Operating Input Range
- 0.28Ω Internal Power MOSFET Switch
- Analog and PWM Dimming
- 0.198V Reference Voltage
- 5µA Shutdown Mode
- Stable with Low ESR Capacitors
- Cycle-by-Cycle Over-Current Protection (OCP)
- Thermal Shutdown, Over-Voltage (OVP), Short-Circuit (SCP), and Open-String Protection
- AEC-Q100 Qualified

APPLICATIONS

- General LED Illumination
- LCD Backlight Panels
- Automotive Lighting

All MPS parts are lead-free, halogen-free, and adhere to the RoHS directive. For MPS green status, please visit the MPS website under Quality Assurance. "MPS" and "The Future of Analog IC Technology" are registered trademarks of Monolithic Power Systems, Inc.

TYPICAL APPLICATION

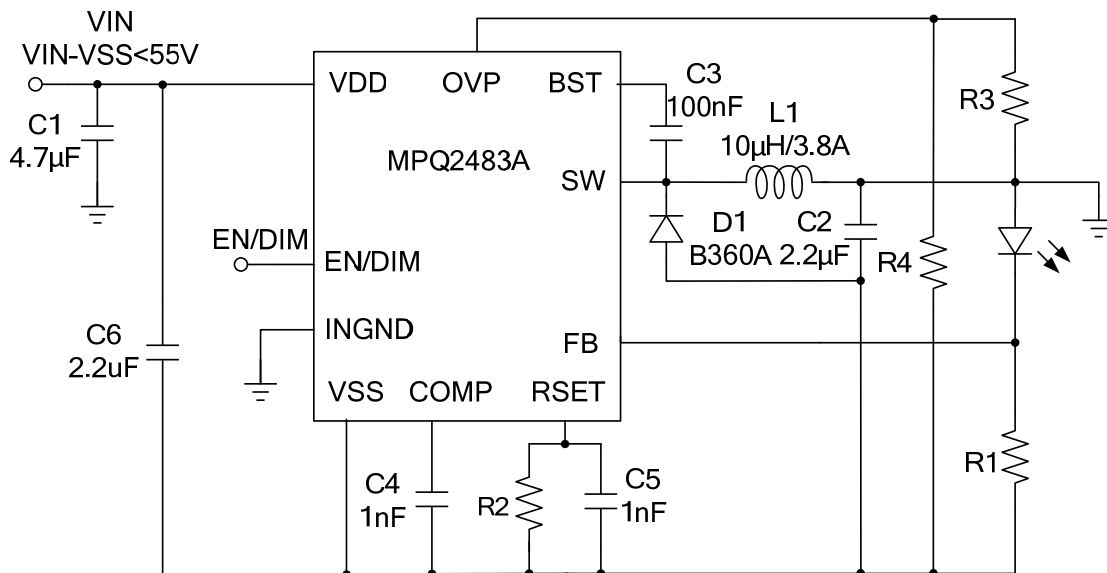

ORDERING INFORMATION

| Part Number | Package | Top Marking |
|-----------------|------------------|-------------|
| MPQ2483ADQ* | QFN-10 (3mmx3mm) | See Below |
| MPQ2483ADQ-AEC1 | QFN-10 (3mmx3mm) | See Below |
| MPQ2483ADS** | SOIC-14 | See Below |
| MPQ2483ADS-AEC1 | SOIC-14 | See Below |

* For Tape & Reel, add suffix –Z (e.g. MPQ2483ADQ–Z)

For RoHS compliant packaging, add suffix –LF (e.g. MPQ2483ADQ–LF–Z)

** For Tape & Reel, add suffix –Z (e.g. MPQ2483ADS–Z)

For RoHS compliant packaging, add suffix –LF (e.g. MPQ2483ADS–LF–Z)

TOP MARKING (MPQ2483ADQ)

—
ATKY
LLL

ATK: Product code of MPQ2483ADQ

Y: Year code

LLL: Lot number

TOP MARKING (MPQ2483ADS)

MPSYYWW
MP2483A
LLLLLLLLLL

MPS: MPS prefix

YY: Year code

WW: Week code

MP2483A: Part number

LLLLLLLLLL: Lot number

PACKAGE REFERENCE

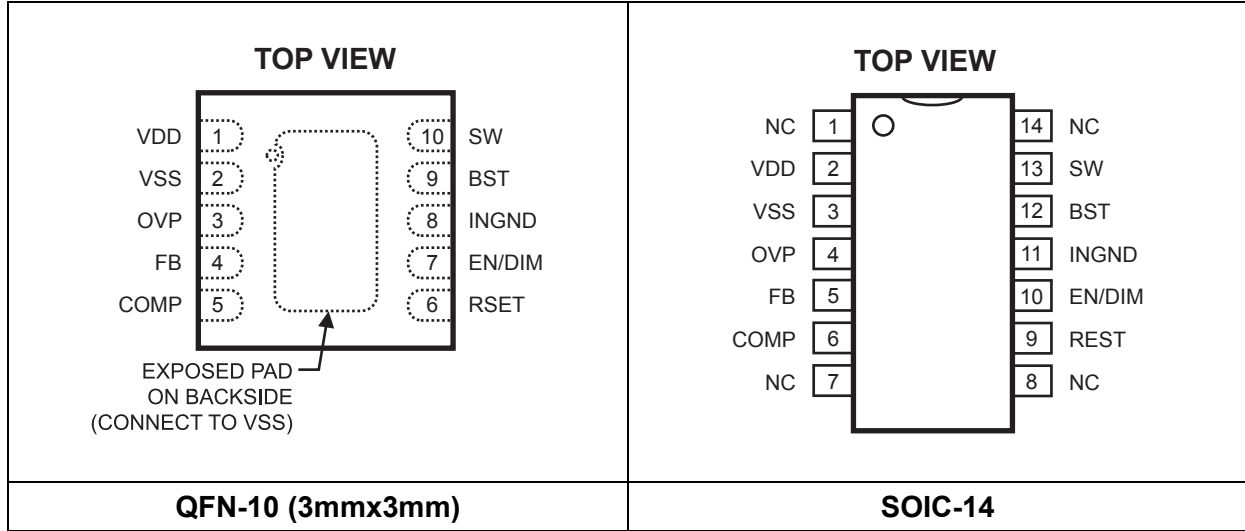

ABSOLUTE MAXIMUM RATINGS ⁽¹⁾

| | |
|---|---------------------------------|
| $V_{DD} - V_{SS}$ ($0^{\circ}\text{C} \leq T_J \leq 125^{\circ}\text{C}$) | 60V |
| $V_{DD} - V_{SS}$ ($-40^{\circ}\text{C} \leq T_J < 0^{\circ}\text{C}$) | 58V |
| $V_{SW} - V_{SS}$ | -0.3V to $V_{DD} + 0.3\text{V}$ |
| V_{BST} | $V_{SW} + 6\text{V}$ |
| $V_{OVP} - V_{SS}$ | -0.3V to +6V |
| $V_{EN} - V_{INGND}$ | -0.3V to +6V |
| $V_{DIM} - V_{INGND}$ | -0.3V to +6V |
| $V_{INGND} - V_{SS}$ | -0.3V to 60V |
| Other pins - V_{SS} | -0.3V to 6V |
| Continuous power dissipation ($T_A = +25^{\circ}\text{C}$) ⁽²⁾ | |
| QFN-10 (3mmx3mm) | 2.5W |
| SOIC-14 | 1.54W |
| Junction temperature | 150°C |
| Lead temperature | 260°C |
| Storage temperature | -65°C to +150°C |

Recommended Operating Conditions ⁽³⁾

| | |
|---|-----------------|
| Supply voltage ($V_{DD} - V_{SS}$) | |
| $0^{\circ}\text{C} \leq T_J \leq 125^{\circ}\text{C}$ | 4.5V to 55V |
| $-40^{\circ}\text{C} \leq T_J < 0^{\circ}\text{C}$ | 4.5V to 50V |
| Operating junction temp. (T_J) | -40°C to +125°C |

Thermal Resistance ⁽⁴⁾

| | θ_{JA} | θ_{JC} |
|------------------|---------------|---------------|
| QFN-10 (3mmx3mm) | 50 | 12 ... °C/W |
| SOIC-14 | 86 | 38 ... °C/W |

NOTES:

- 1) Exceeding these ratings may damage the device.
- 2) The maximum allowable power dissipation is a function of the maximum junction temperature T_J (MAX), the junction-to-ambient thermal resistance θ_{JA} , and the ambient temperature T_A . The maximum allowable continuous power dissipation at any ambient temperature is calculated by P_D (MAX) = $(T_J$ (MAX) - T_A) / θ_{JA} . Exceeding the maximum allowable power dissipation produces an excessive die temperature, causing the regulator to go into thermal shutdown. Internal thermal shutdown circuitry protects the device from permanent damage.
- 3) The device is not guaranteed to function outside of its recommended operating conditions.
- 4) Measured on JESD51-7, 4-layer PCB.

ELECTRICAL CHARACTERISTICS

$V_{IN} = 12V$, $T_J = -40^{\circ}C$ to $+125^{\circ}C$, all voltages with respect to V_{SS} . Typical values are based on the average value when $T_J = 25^{\circ}C$, unless otherwise noted.

| Parameters | Symbol | Condition | Min | Typ | Max | Units |
|--|-------------------|---|-------|-------|-------|-------------|
| Feedback voltage | V_{FB} | $4.5V \leq V_{IN} \leq 12V$ | 0.180 | 0.198 | 0.215 | V |
| | | $12V \leq V_{IN} \leq 55V$ | 0.170 | 0.198 | 0.220 | |
| Feedback current | I_{FB} | $V_{FB} = 0.22V$ | | | 1.0 | μA |
| Switch-on resistance | $R_{DS(ON)}$ | | | 280 | | m Ω |
| Switch leakage | | $V_{EN} = 0V, V_{SW} = 0V$ | | | 2 | μA |
| Current limit ⁽⁵⁾ | I_{LIM} | $-40^{\circ}C \leq T_J \leq 125^{\circ}C$, duty cycle $\leq 61\%$ | 2.7 | 3.0 | | A |
| Oscillator frequency | f_{SW} | $V_{FB} = 0.19V$, $RSET = 200k\Omega$ | | 0.25 | | MHz |
| Oscillator frequency ⁽⁶⁾ | f_{SW} | $V_{FB} = 0.19V$, $RSET = 124k\Omega$ | 0.31 | 0.41 | 0.51 | MHz |
| Default oscillator frequency | $f_{SW_default}$ | $V_{FB} = 0.19V$, RSET open | 1.0 | 1.35 | 1.7 | MHz |
| Foldback frequency | | $V_{FB} = 0V, V_{OVP} = 0V$, RSET open | | 250 | | kHz |
| Maximum duty cycle | | $V_{FB} = 0.19V$ | | 90 | | % |
| Minimum on time ⁽⁵⁾ | t_{ON} | | | 100 | | ns |
| Under-voltage lockout threshold rising | | | 2.9 | 3.3 | 3.7 | V |
| Under-voltage lockout threshold hysteresis | | | | 200 | | mV |
| EN input current | | $V_{EN} = 2V$ | | 1.4 | | μA |
| EN off threshold (with respect to INGND) | | V_{EN} falling | 0.4 | | | V |
| EN on threshold (with respect to INGND) | | V_{EN} rising | | | 0.6 | V |
| Minimum EN dimming threshold | | $V_{FB} = 0V$ | 0.55 | 0.7 | 0.85 | V |
| Maximum EN dimming threshold | | $V_{FB} = 0.2V$ | 1.2 | 1.4 | 1.55 | V |
| Supply current (quiescent) | I_Q | $V_{EN} = 2V, V_{FB} = 1V$ | | 0.8 | 1.5 | mA |
| Shutdown current | I_{off} | $V_{EN} = 0V$ | | 3.4 | 20 | μA |
| Thermal shutdown ⁽⁵⁾ | | | | 150 | | $^{\circ}C$ |
| Open LED OV threshold | V_{OVP_th} | | 1.1 | 1.2 | 1.3 | V |
| Open LED OV hysteresis | V_{OVP_hys} | | | 60 | | mV |

NOTE:

- 5) Derived from part characterization. Not tested in production.
- 6) Only tested on QFN package.

TYPICAL PERFORMANCE CHARACTERISTICS

$V_{IN} = 20V$, $I_{LED} = 0.7A$, two 3W LED in series, step-down application, unless otherwise noted.

LED Current vs. Dimming Duty

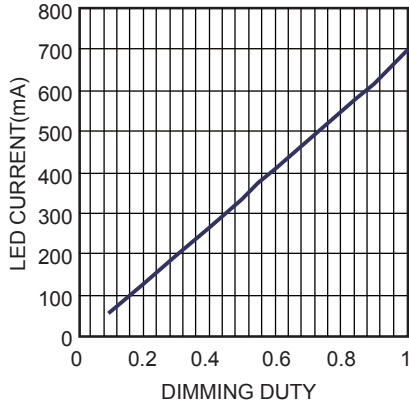

LED Current vs. VEN

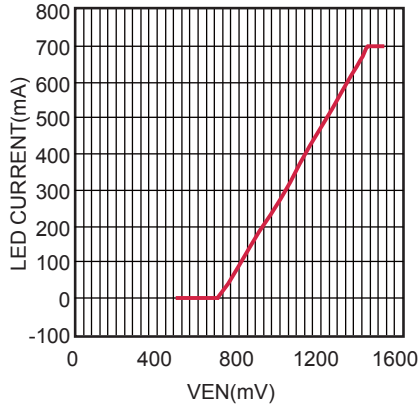

IPEAK vs. Duty

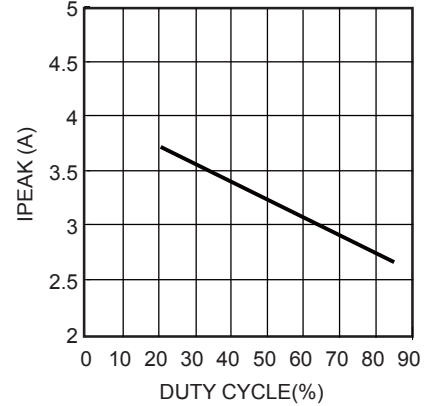

Efficiency vs. Input Voltage

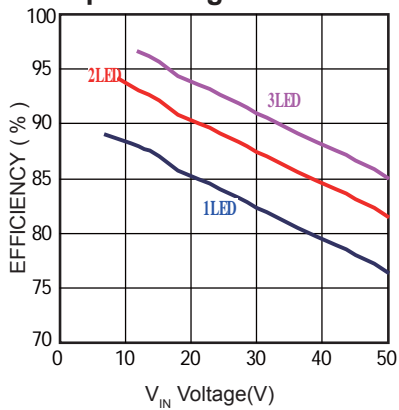

I_Q vs. Temperature

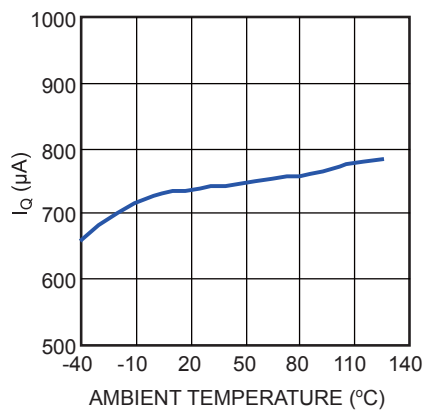

V_{FB} vs. Temperature

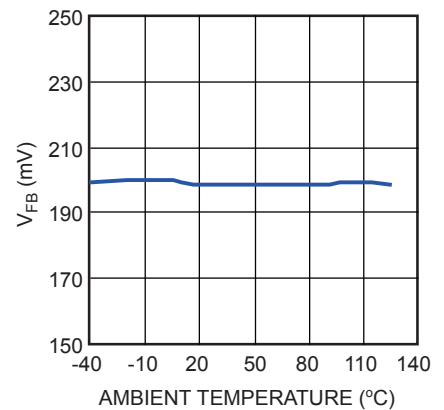

F_{sw} vs. Temperature

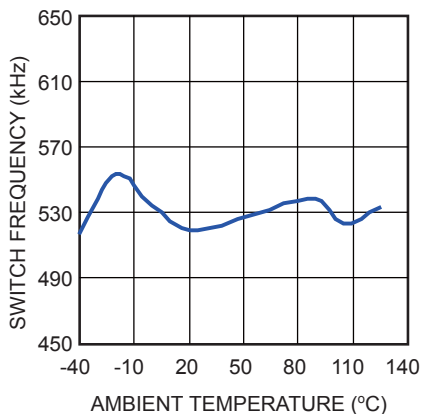

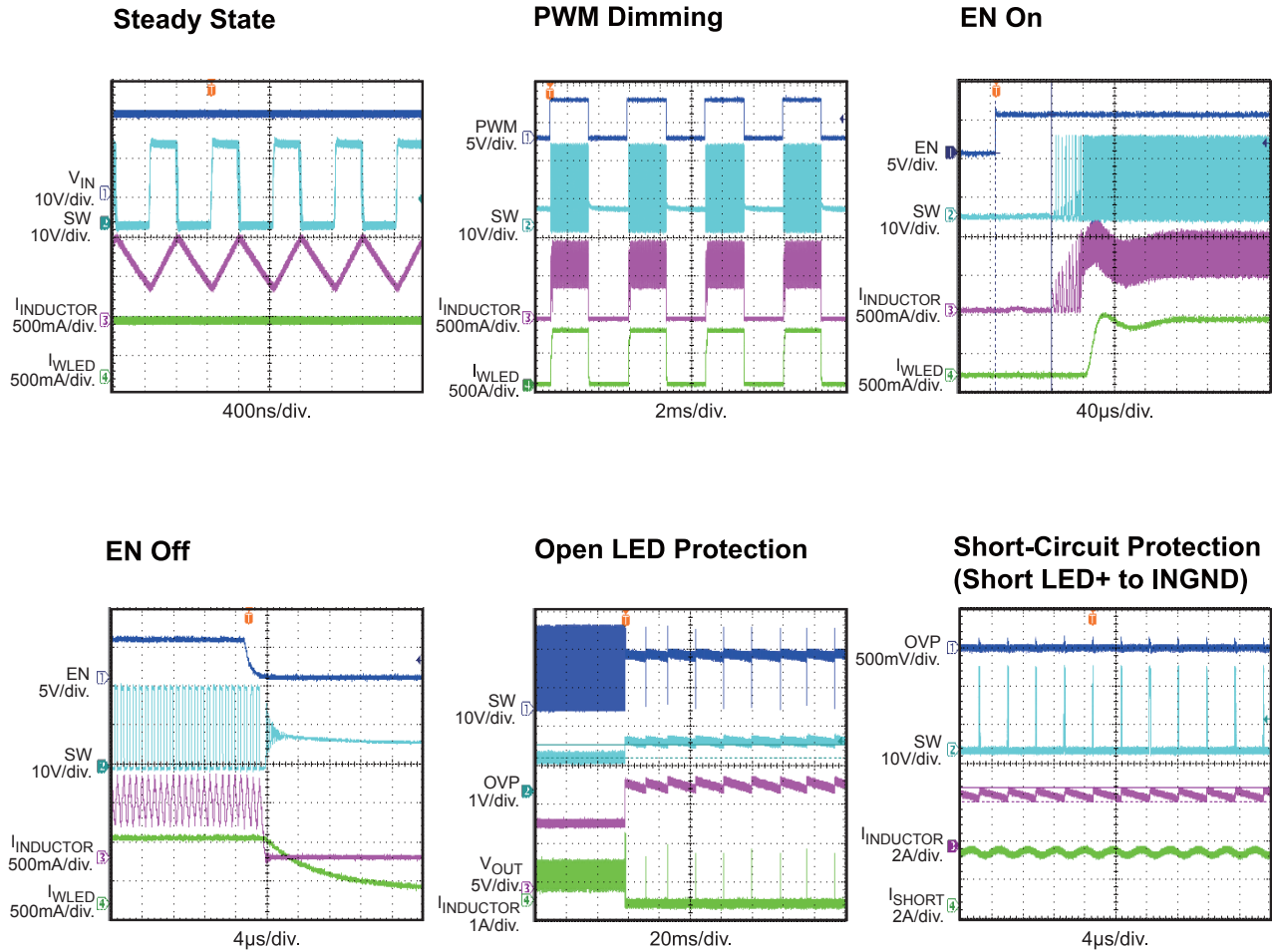
TYPICAL PERFORMANCE CHARACTERISTICS (continued)
 $V_{IN} = 20V$, $I_{LED} = 0.7A$, two 3W LED in series, step-down application, unless otherwise noted.

TYPICAL PERFORMANCE CHARACTERISTICS *(continued)*

$V_{IN} = 20V$, $I_{LED} = 0.7A$, seven 3W LED in series, buck-boost application, referred to V_{SS} , unless otherwise noted.

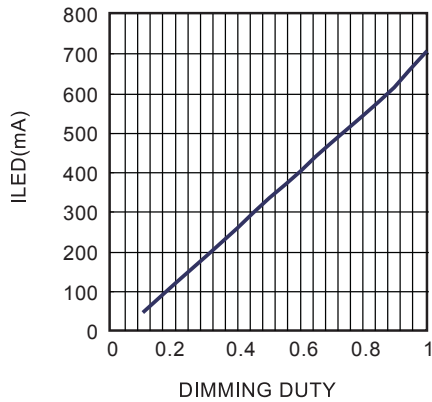
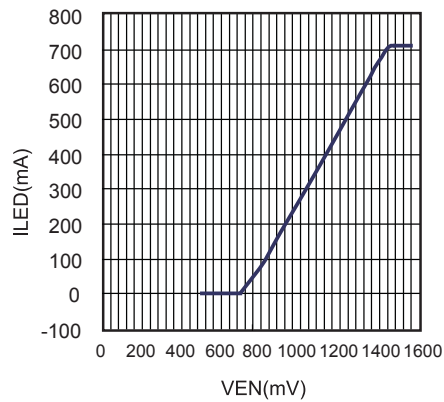
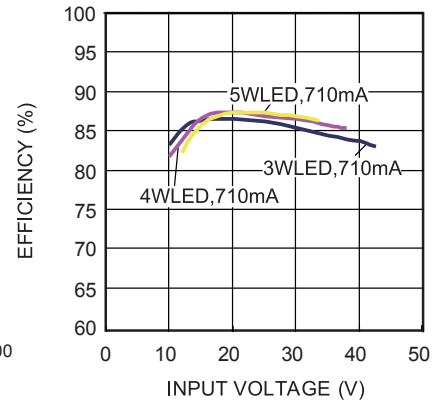
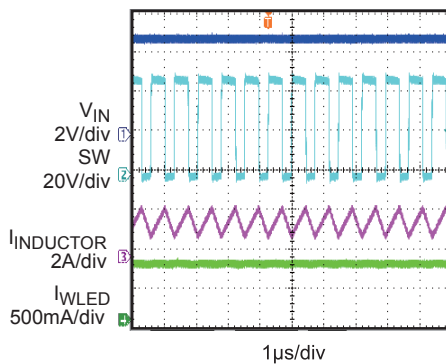
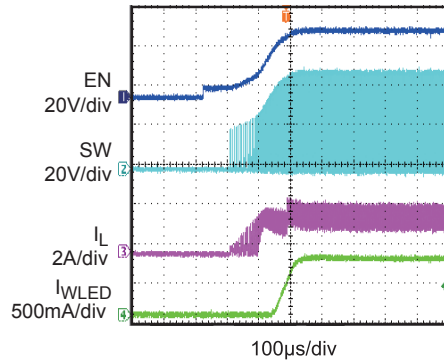
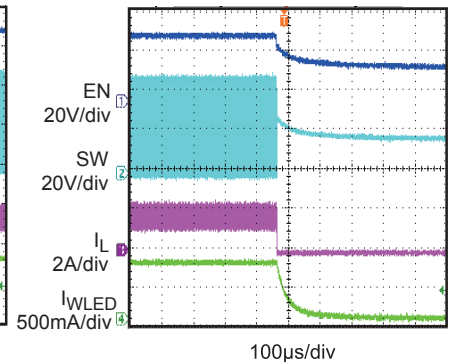
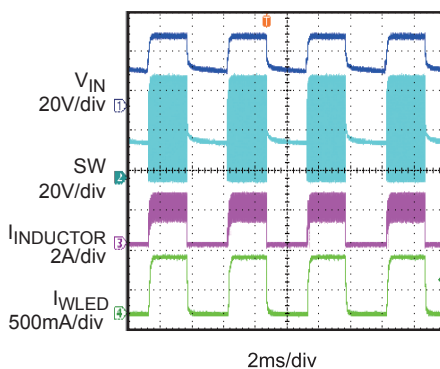
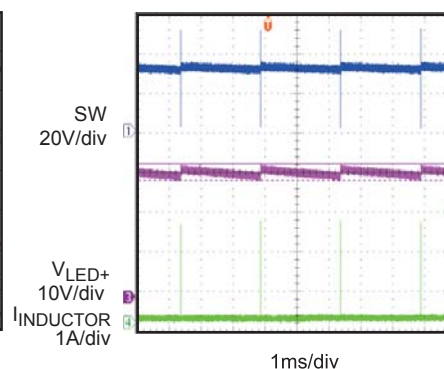
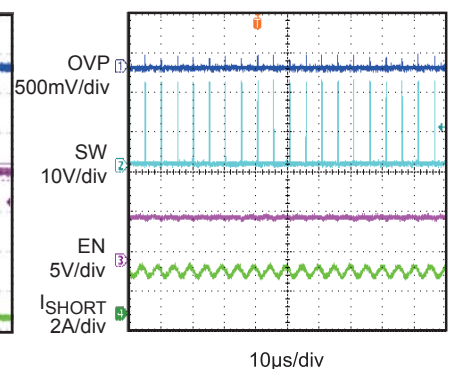
I_{LED} vs. Dimming Duty

I_{LED} vs. VEN

Efficiency vs. Input Voltage

Steady State

EN On

EN Off

PWM Dimming

Open LED Protection

Short-Circuit Protection (Short LED + to VSS)

PIN FUNCTIONS

| QFN-10 Pin # | SOIC-14 Pin # | Name | Description |
|-----------------|------------------|-------------|--|
| 1 | 2 | VDD | Supply voltage. The MPQ2483A operates from a +4.5V to +55V unregulated input with respect to VSS. C1 and C2 are needed to prevent large voltage spikes from occurring at input. |
| 2 | 3 | VSS | Power return. Connect VSS to the lowest potential in the circuit, typically the Schottky rectifier anode. VSS is the voltage reference for the regulated output voltage. Place VSS outside of the D1 to C1 and C2 ground paths to prevent switching current spikes from inducing voltage noise in the part. The exposed pad is also connected to VSS. |
| 3 | 4 | OVP | Over-voltage protection. Use a voltage divider to program the OVP threshold. When the OVP voltage reaches the shutdown threshold of 1.2V, the switch turns off and recovers when the OVP voltage decreases sufficiently. When the OVP voltage (with respect to VSS) is lower than 0.4V, and the FB voltage is lower than 0.1V, the chip recognizes this as a short-circuit condition, and the operating frequency folds back. Program the OVP voltage from 0.4V to 1.2V for normal operation. |
| 4 | 5 | FB | LED current feedback input. The MPQ2483A regulates the voltage across the current-sensing resistor between FB and VSS. Connect the current-sensing resistor from the bottom of the LED strings to VSS. FB is connected to the bottom of the LED strings. The regulation voltage is 0.198V. |
| 5 | 6 | COMP | Error amplifier output. Connect a capacitor 1nF or larger to COMP to improve stability, provide PWM dimming, and provide a soft-on at start-up. |
| 6 | 9 | RSET | Frequency set. Connect a resistor to VSS to set the switching frequency. Connect a 1nF capacitor to VSS to bypass the noise. When RSET is left open, the default operating frequency is 1.35MHz. |
| 7 | 10 | EN/DIM | On/Off control input and dimming command input. A voltage greater than 0.6V turns the chip on. Both DC and PWM dimming are implemented on EN/DIM. When the EN/DIM voltage (with respect to INGND) rises from 0.7V to 1.4V, the LED current changes from 0% to 100% of the maximum LED current. To use PWM dimming, apply a 100Hz to 2kHz square wave signal with an amplitude greater than 1.4V to EN/DIM. |
| 8 | 11 | INGND | Input ground reference. INGND is the reference for the EN/DIM signal. |
| 9 | 12 | BST | Bootstrap. A capacitor is connected between SW and BST to form a floating supply across the power switch driver. A ceramic capacitor of 100nF or larger is recommended to provide sufficient energy to drive the power switch's gate above the supply voltage. |
| 10 | 13 | SW | Switch output. SW is the source of the internal MOSFET switch. Connect SW to the power inductor and the cathode of the Schottky rectifier. |
| | 1, 7, 8, 14 | NC | No connection. |
| | | Exposed Pad | Connect exposed pad to VSS in step-up/down mode. |

FUNCTIONAL BLOCK DIAGRAM

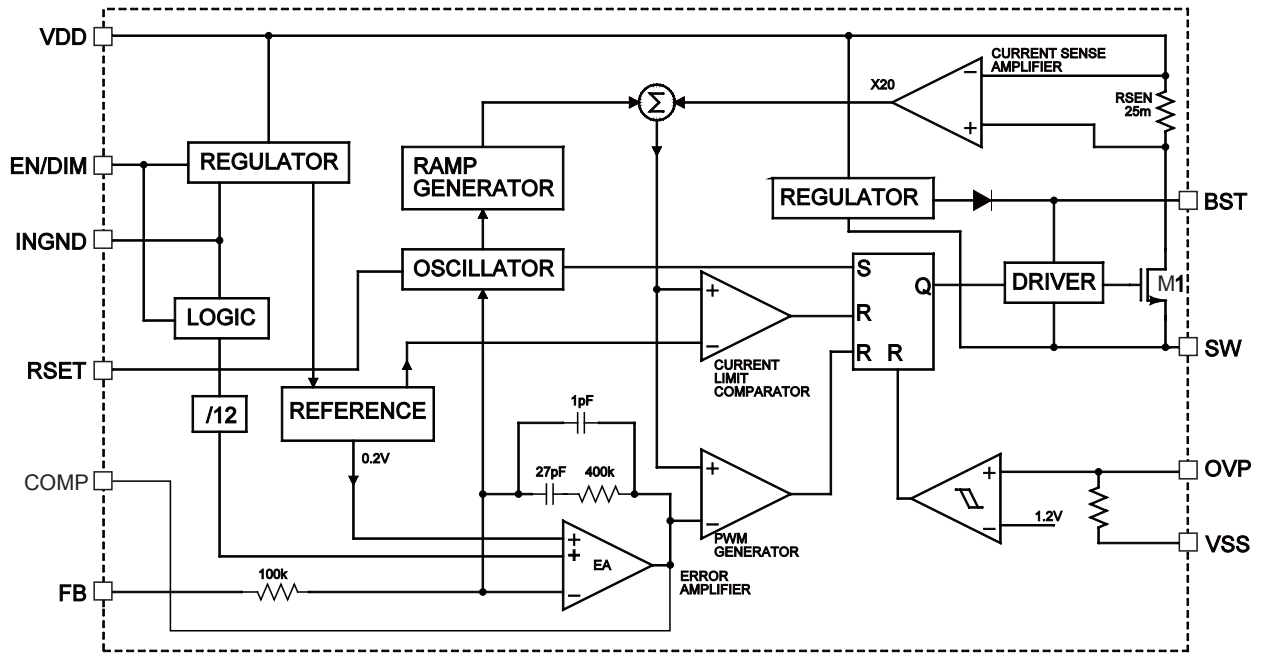

Figure 1: Functional Block Diagram

OPERATION

The MPQ2483A is a current-mode regulator. The error amplifier (EA) output voltage is proportional to the peak inductor current.

At the beginning of a cycle, M1 is off. The EA output voltage is higher than the current sense amplifier output, and the current comparator's output is low. The rising edge of the 1.35MHz CLK signal sets the RS flip-flop. Its output turns M1 on and connects SW and the inductor to the input supply.

The increasing inductor current is sensed and amplified by the current sense amplifier. Ramp compensation is summed to the current sense amplifier output and is compared to the error amplifier output by the PWM comparator. When the sum of the current sense amplifier output and the slope compensation signal exceeds the EA output voltage, the RS flip-flop is reset, and M1 is turned off. The external Schottky rectifier diode (D1) conducts the inductor current.

If the sum of the current sense amplifier output and the slope compensation signal does not exceed the EA output for the entire cycle, then the falling edge of the CLK resets the flip-flop.

The output of the error amplifier integrates the voltage difference between the feedback and the 0.198V reference. The polarity is a FB voltage lower than 0.198V, which increases the EA output voltage. Since the EA output voltage is proportional to the peak inductor current, an increase in its voltage also increases the current delivered to the output.

Open LED Protection

If the LED is open, there is no voltage on FB. The duty cycle increases until OVP-VSS reaches the shutdown threshold set by the external resistor divider. The top switch turns off and remains off until the voltage on OVP-VSS decreases sufficiently.

Dimming Control

The MPQ2483A allows for both DC and PWM dimming. When the voltage on EN is less than 0.6V, the chip turns off.

For analog dimming, the LED current changes from 0% to 100% of the maximum LED current when the voltage on EN is between 0.7V and 1.4V. If the voltage on EN is higher than 1.4V, a maximum LED current is generated.

For PWM dimming, the VDIM-VINGND amplitude must exceed 1.4V. The PWM frequency is recommended to be in the range of 100Hz to 2kHz for optimal dimming linearity.

Output Short-Circuit Protection

The MPQ2483A has output short-circuit protection. When the output is shorted to VSS, the voltage on OVP (which detects the output voltage) drops to under 0.4V. FB cannot sense any voltage (<0.1V) since there is no current running through the LED. In this condition, the operating frequency is folded back to decrease power consumption.

APPLICATION INFORMATION

Setting the LED Current

The external resistor is used to set the maximum LED current and can be calculated with Equation (1):

$$R_{\text{SENSE}} = \frac{0.198\text{V}}{I_{\text{LED}}} \quad (1)$$

Setting the Operating Frequency

The resistor on RSET is used to set the operating frequency. A 1nF capacitor is recommended to bypass RSET to GND.

The relationship between the operating frequency and the RSET resistor is shown in the curve in Figure 2. A 20kΩ to 200kΩ RSET resistor is recommended to set the operating frequency from around 1.35MHz to 250 kHz. Leaving RSET open sets the operating frequency to the default 1.35MHz.

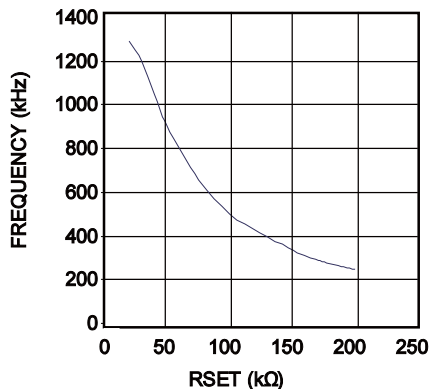

Figure 2: Frequency vs. RSET

Selecting the Inductor

A 1μH to 47μH inductor with a DC current rating at least 25% higher than the maximum load current is recommended for most applications. For high efficiency, the inductor's DC resistance should be less than 200mΩ. Refer to Table 1 on page 13 for suggested surface mount inductors. For most designs, calculate the required inductance value with Equation (2):

$$L = \frac{V_{\text{OUT}} \times (V_{\text{IN}} - V_{\text{OUT}})}{V_{\text{IN}} \times \Delta I_L \times f_{\text{SW}}} \quad (2)$$

Where ΔI_L is the inductor ripple current.

Choose the inductor ripple current to be 30% of the maximum load current. The maximum inductor peak current can be calculated with Equation (3):

$$I_{L(\text{MAX})} = I_{\text{LOAD}} + \frac{\Delta I_L}{2} \quad (3)$$

Note that under light-load conditions below 100mA, a larger inductance is recommended for improved efficiency.

Also note that the maximum recommended load current is 2A if the duty cycle exceeds 35%.

Selecting the Input Capacitor

The input capacitor reduces the surge current drawn from the input supply and the switching noise from the device. The input capacitor impedance at the switching frequency should be less than the input source impedance to prevent a high-frequency switching current from passing through the input. Ceramic capacitors with X5R or X7R dielectrics are recommended highly because of their low ESR and small temperature coefficients. For most applications, a 4.7μF capacitor is sufficient.

Selecting the Output Capacitor

The output capacitor keeps the output voltage ripple small and ensures a stable feedback loop. The output capacitor impedance should be low at the switching frequency. Ceramic capacitors with X5R or X7R dielectrics are recommended for their low ESR characteristics. For most applications, a 2.2μF ceramic capacitor is sufficient.

Selecting VSS-INGND Positive Spike-Protection Circuit

In some applications, such as input power-on, LED+ can short circuit from LED+ to VSS in both buck boost and boost applications. When INGND and VSS are not connected, there is a potential risk that VSS-INGND can have a >0.3V positive spike, which may cause false actions or damage.

To clamp the VSS-INGND positive spike, it is recommended to add a 100Ω resistor from INGND to input GND to clamp the current from VSS to INGND. Add a low forward voltage Schottky diode (e.g. B160) from VSS to INGND to clamp the negative oscillation voltage (see Figure 3). The voltage rating of the Schottky diode should be higher than the OVP voltage set by R3 and R4.

For extremely high VSS-INGND spike conditions, a bigger R2 and a higher current rating for D2 are needed to clamp the current.

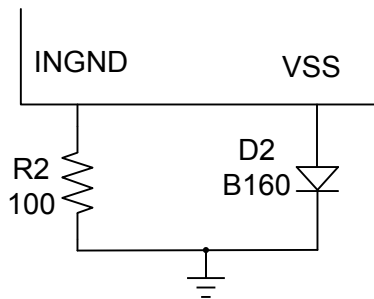

Figure 3: VSS-INGND Positive Spike-Protection Circuit

Selecting the FB Positive Spike-Protection Circuit

In applications where there is a possibility that FB can have an abnormally high positive spike, such as load transients from high to low, or LED+ short circuit from LED+ to LED- in buck, boost, and buck-boost applications, an abnormally high positive spike on FB can create false actions or damage.

To protect FB from positive spikes that are too high, it is recommended to add a 10kΩ resistor between LED- and FB to clamp the current from LED- to FB, and to add a <2V voltage range Zener diode (e.g. BZT52C2V0) from FB to VSS to clamp the voltage from FB to VSS (see Figure 4).

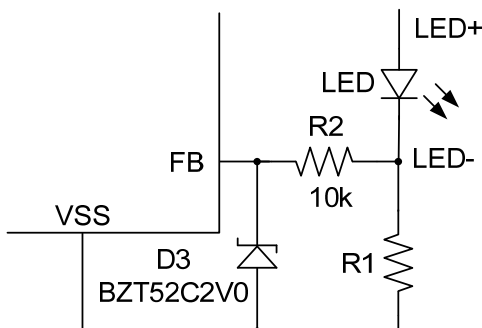

Figure 4: FB Positive Spike-Protection Circuit

PCB Layout Guidelines

Efficient PCB layout is critical for stable operation. For best results, follow the guidelines below.

1. Place the high-current paths (VSS, VDD, and SW) as close to the device as possible with short, direct, and wide traces.
2. Place the input capacitor as close to VDD and VSS as possible.
3. Place the external feedback resistors next to FB.
4. Keep the switch node traces short and away from the feedback network.

Table 1: Suggested Surface Mount Inductors

| Manufacturer | Part Number | Inductance (μH) | Max DCR (Ω) | Current Rating (A) | Dimensions LxWxH (mm ³) |
|--------------|----------------------|-----------------|-------------|--------------------|-------------------------------------|
| Toko | DS84LC-B1015AS-4R7N | 4.7 | 0.038 | 3.8 | 8.2x8.1x3.7 |
| Cooper | DR73-4R7-R | 4.7 | 0.0297 | 3.78 | 7.35x7.35x3.3 |
| TDK | SLF7055T-4R7N3R1-3PF | 4.7 | 0.028 | 3.6 | 7.1x7.3x5.5 |

TYPICAL APPLICATION CIRCUITS

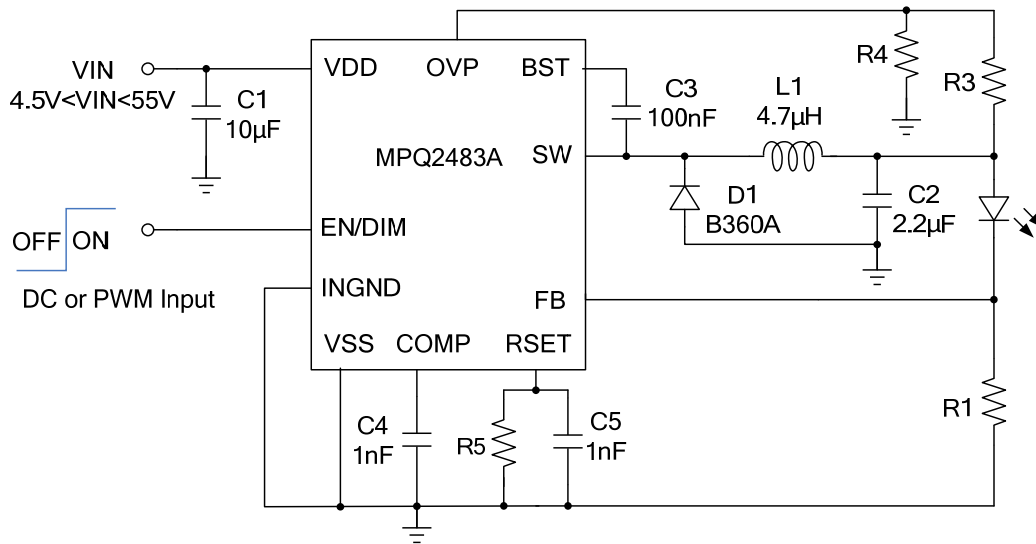
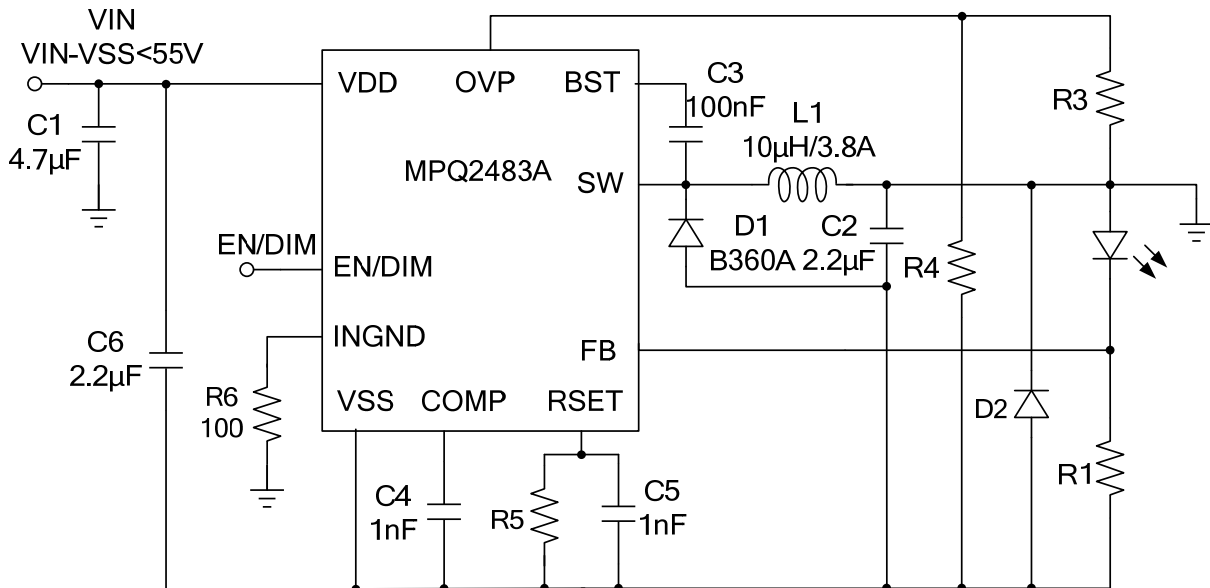
Figure 5: Step-Down LED Driver Application

Figure 6: Step-Up/Down LED Driver Application

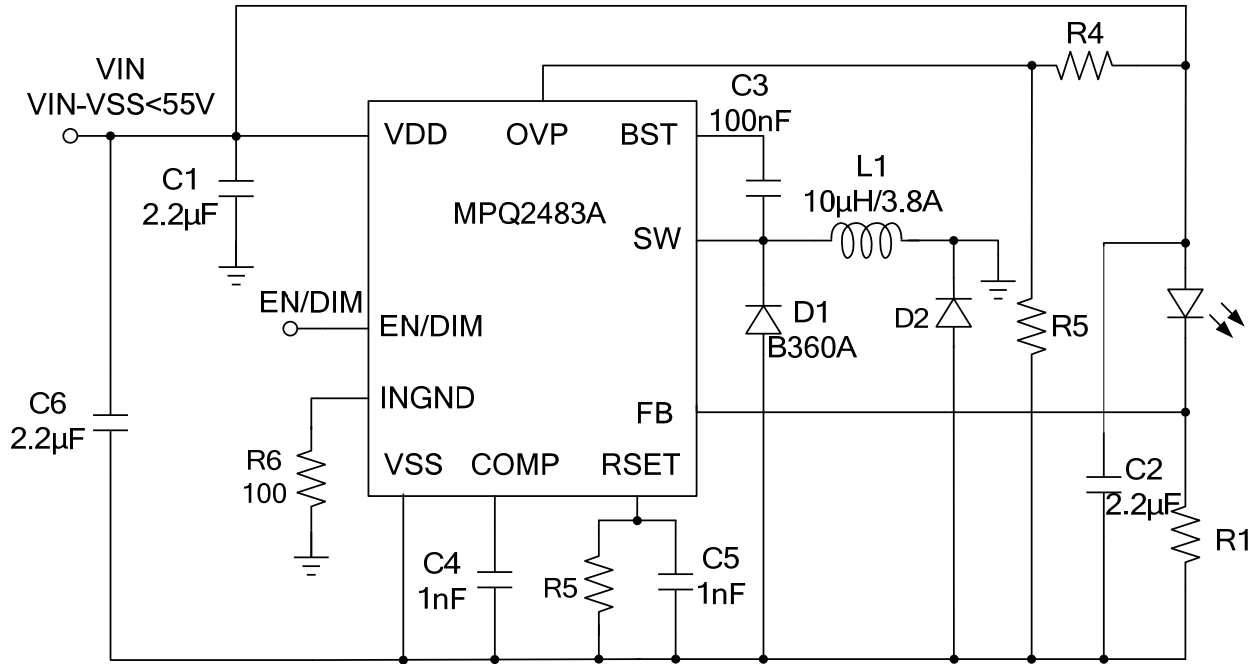
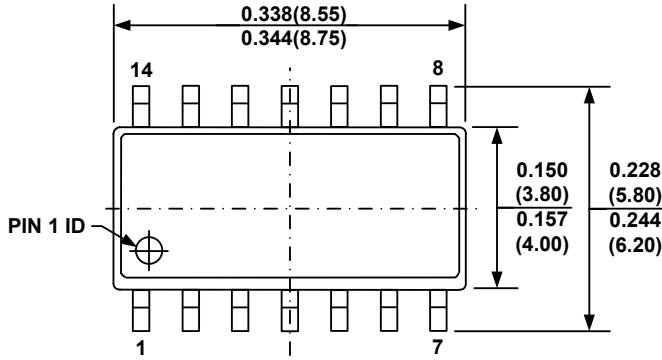

Figure 7: Step-Up LED Driver Application

PACKAGE INFORMATION

SOIC-14



TOP VIEW

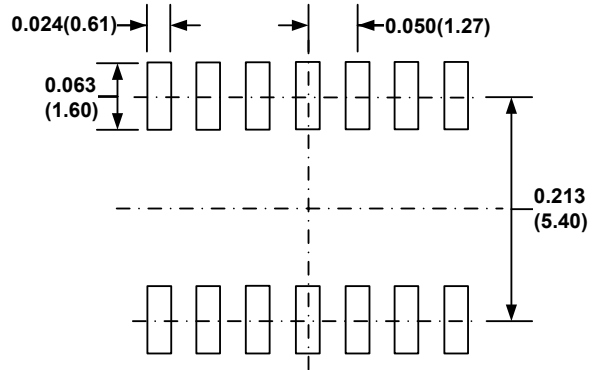

RECOMMENDED LAND PATTERN

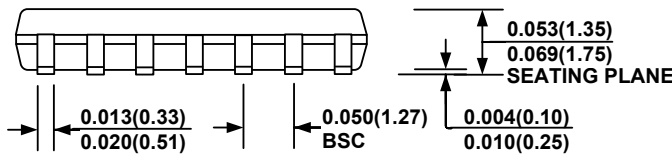

FRONT VIEW

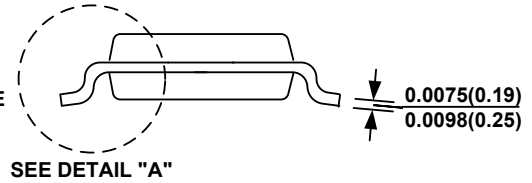

SIDE VIEW

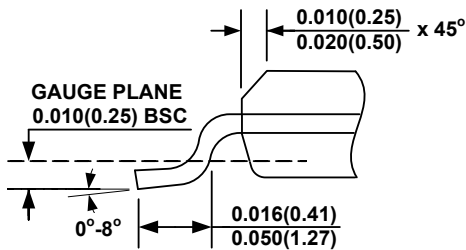

DETAIL "A"

NOTE:

- 1) CONTROL DIMENSION IS IN INCHES. DIMENSION IN BRACKET IS IN MILLIMETERS.
- 2) PACKAGE LENGTH DOES NOT INCLUDE MOLD FLASH, PROTRUSIONS OR GATE BURRS.
- 3) PACKAGE WIDTH DOES NOT INCLUDE INTERLEAD FLASH OR PROTRUSIONS.
- 4) LEAD COPLANARITY (BOTTOM OF LEADS AFTER FORMING) SHALL BE 0.004" INCHES MAX.
- 5) DRAWING CONFORMS TO JEDEC MS-012, VARIATION AB.
- 6) DRAWING IS NOT TO SCALE.

PACKAGE INFORMATION

QFN-10 (3mmx3mm)

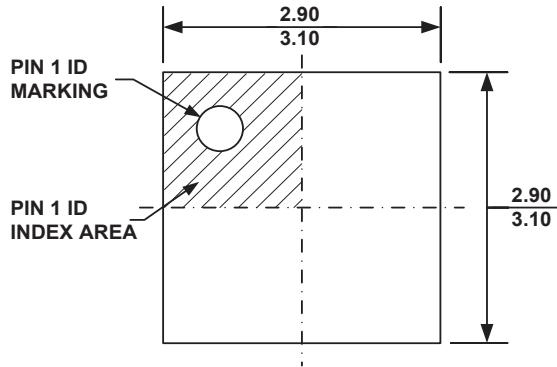

TOP VIEW

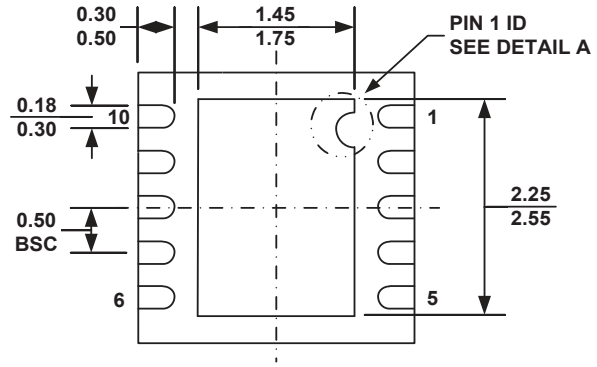

BOTTOM VIEW

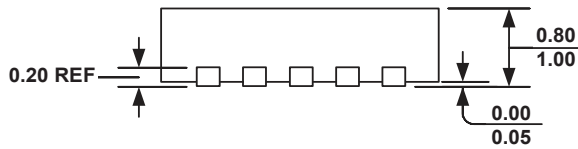

SIDE VIEW

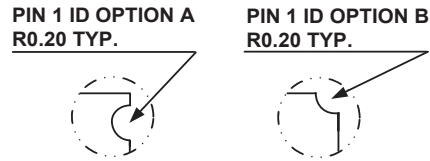

DETAIL A

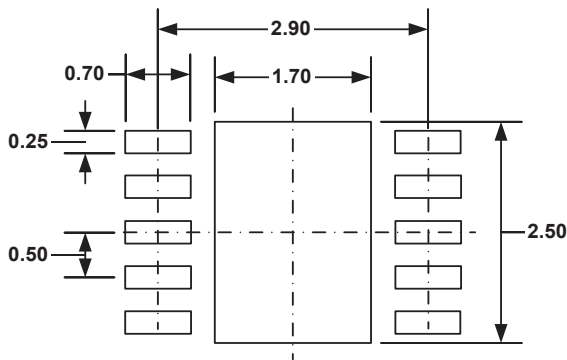

RECOMMENDED LAND PATTERN

NOTE:

- 1) ALL DIMENSIONS ARE IN MILLIMETERS.
- 2) EXPOSED PADDLE SIZE DOES NOT INCLUDE MOLD FLASH.
- 3) LEAD COPLANARITY SHALL BE 0.10 MILLIMETER MAX.
- 4) DRAWING CONFORMS TO JEDEC MO-229, VARIATION VEED-5.
- 5) DRAWING IS NOT TO SCALE.

NOTICE: The information in this document is subject to change without notice. Users should warrant and guarantee that third party Intellectual Property rights are not infringed upon when integrating MPS products into any application. MPS will not assume any legal responsibility for any said applications.

Looking for pricing, stock, or lifecycle information?

Click below to explore more details on WIN SOURCE:

- [View MPQ2483ADQ-AEC1-LF-Z on WIN SOURCE](#)
- [Monolithic Power Systems Inc. Information](#)

Optimize Your Supply Chain with WIN SOURCE Solutions

- ✓ Global Sourcing Solution
- ✓ Obsolete Management
- ✓ Cost Control Management
- ✓ Shortage Management
- ✓ Alternative Solution
- ✓ Excess Inventory Management