



**THE DATASHEET OF
MP5090GC-Z**



DESCRIPTION

The MP5090 integrates dual load switches to provide load protection covering a 0.5V to 5.5V voltage range. Each channel provides up to 3A/2A of load protection covering a 0.5V to 5.5V voltage range with a 1.85V VCC power supply. With a small R_{DS(ON)} in a tiny package, the MP5090 provides a highly efficient and space-saving solution for notebook, tablet, and other portable device applications.

With an internal soft-start function, the MP5090 can prevent inrush current during circuit start-up. The MP5090 also provides internal current limit, hiccup protection, and thermal shutdown features. The MP5090 also parallels both channels easily to double the current capability.

The MP5090 is available in TQFN-8 (1.5mmx2.0mm) and 8-ball CSP (1.05mmx1.60mm) packages.

FEATURES

- Low Quiescent Current: 40µA
- Wide V_{IN} Range from 0.5V to 5.5V
- <1µA Shutdown Current
- Output Discharge Function
- Continuous Current Capability
 - MP5090GQHT: 3A
 - MP5090GC: 2A
- Integrated Low R_{DS(ON)} MOSFETs
 - MP5090GQHT: 20mΩ
 - MP5090GC: 30mΩ
- Enable Pin (EN1, EN2)
- Short-Circuitry Response Protection
- Easily Parallel-Connect Dual Channel
- Supports Reverse Block Connection
- Thermal Protection
- Available in TQFN-8 (1.5mmx2.0mm) and 8-Ball CSP (1.05mmx1.60mm) Packages

APPLICATIONS

- Notebook and Tablet Computers
- Portable Devices
- Solid-State Drives
- Handheld Devices

All MPS parts are lead-free, halogen-free, and adhere to the RoHS directive. For MPS green status, please visit MPS website under Quality Assurance. "MPS" and "The Future of Analog IC Technology" are registered trademarks of Monolithic Power Systems, Inc.

TYPICAL APPLICATION

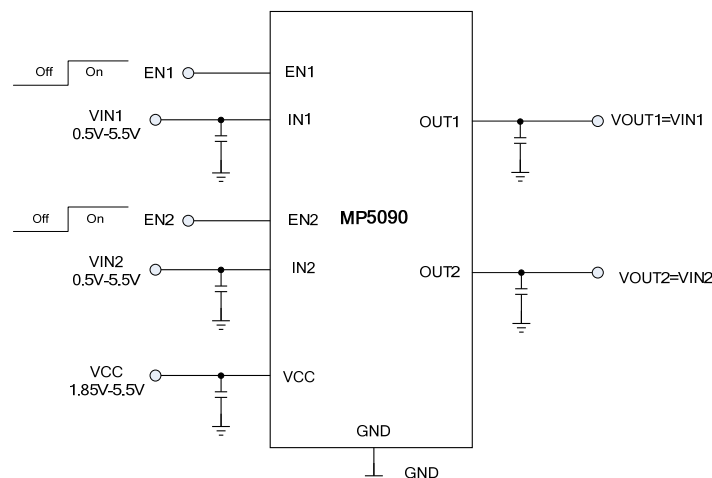

ORDERING INFORMATION

Part Number	Package	Top Marking
MP5090GQHT*	TQFN (1.5mmx2.0mm)	See Below
MP5090GC**	CSP (1.05mmx1.60mm)	See Below

* For Tape & Reel, add suffix -Z (e.g. MP5090GQHT-Z)

** For Tape & Reel, add suffix -Z (e.g. MP5090GC-Z)

TOP MARKING (MP5090GQHT)

—
EE

LL

EE: Product code of MP5090GQHT

LL: Lot number

TOP MARKING (MP5090GC)

—
EMY

LLL

EM: Product code of MP5090GC

Y: Year code

LLL: Lot number

PACKAGE REFERENCE

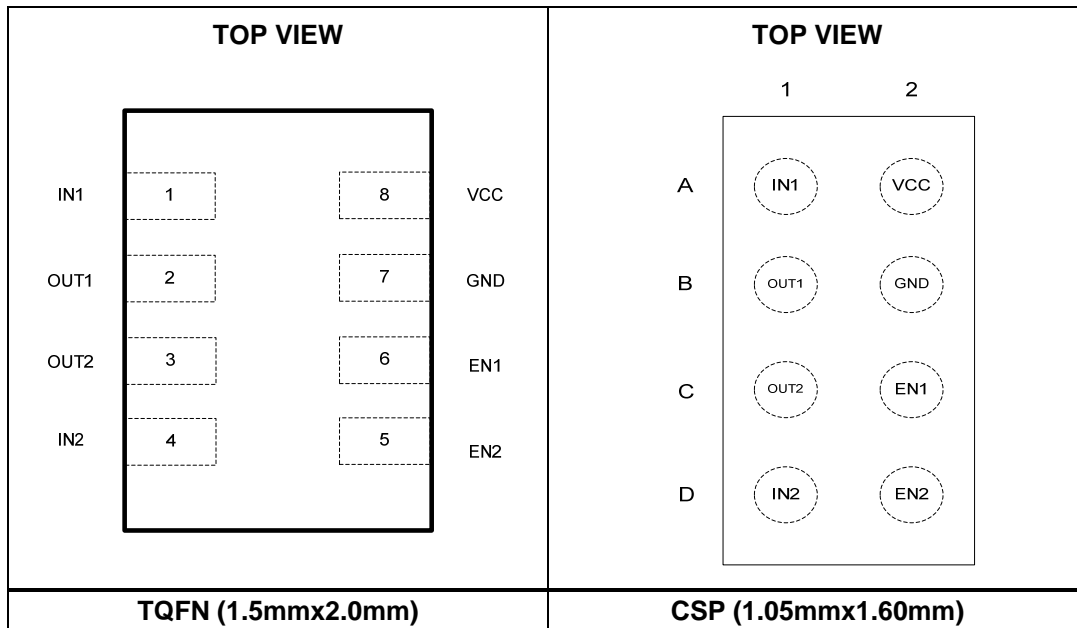

ABSOLUTE MAXIMUM RATINGS ⁽¹⁾

V _{IN1/2}	-0.3V to +6V
VCC	-0.3V to +6V
V _{OUT1/2}	-0.3V to +6V
All other pins	-0.3V to +6V
Junction temperature	150°C
Lead temperature	260°C

Continuous power dissipation ⁽²⁾⁽⁴⁾⁽⁵⁾

TQFN (1.5mmx2.0mm)	3.4W
CSP (1.05mmx1.60mm)	1.7W

Recommended Operating Conditions ⁽³⁾

Supply voltage (V _{IN1/2})	0.5V to 5.5V
Supply voltage (VCC)	1.85V to 5.5V
Output voltage (V _{OUT1/2})	0.5V to 5.5V
Operating junction temp. (T _J)	-40°C to +125°C

<i>Thermal Resistance</i> ⁽²⁾	θ_{JA}	θ_{JC}	
EV5090-C-00A ⁽⁴⁾	69	28	°C/W
TQFN-8 (1.5mmx2.0mm) ⁽⁶⁾	110	55	°C/W
EV5090-Q-00A ⁽⁵⁾	35	6	°C/W
CSP (1.05mmx1.60mm) ⁽⁶⁾	170	NA	°C/W

NOTES:

- 1) Exceeding these ratings may damage the device.
- 2) The maximum allowable power dissipation is a function of the maximum junction temperature T_J (MAX), the junction-to-ambient thermal resistance θ_{JA} , and the ambient temperature T_A. The maximum allowable continuous power dissipation at any ambient temperature is calculated by P_D (MAX) = (T_J (MAX) - T_A) / θ_{JA} . Exceeding the maximum allowable power dissipation produces an excessive die temperature, causing the regulator to go into thermal shutdown. Internal thermal shutdown circuitry protects the device from permanent damage.
- 3) The device is not guaranteed to function outside of its operating conditions.
- 4) Measured on EV5090-C-00A, 2-layer PCB.
- 5) Measured on EV5090-Q-00A, 2-layer PCB.
- 6) Measured on JESD51-7, 4-layer PCB.

ELECTRICAL CHARACTERISTICS

V_{IN} = 3.6V, V_{CC} = 3.6V, T_J = -40°C to +125°C, Typical value is tested at T_J = +25°C. The limit over temperature is guaranteed by characterization, unless otherwise noted.

Parameters	Symbol	Condition	Min	Typ	Max	Units
Input and Supply Voltage Range						
Input voltage	V _{IN1/2}		0.5		5.5	V
Supply voltage	V _{CC}		1.85		5.5	V
Supply Current (Single Channel)						
Off state leakage current	I _{OFF}	V _{IN} = 5V, EN = 0, T _J = 25°C			1	μA
VCC standby current	I _{STBY}	VCC = 3.6V, EN = 0, T _J = 25°C		0.1	1	μA
		VCC = 3.6V, enable, no load		40		
Power MOSFET						
On resistance	R _{DSON1/2}	TQFN, VCC = 5.0V, single channel		20		mΩ
		TQFN, VCC = 3.3V, single channel		24		
	R _{DSON1/2}	CSP, VCC = 5.0V, single channel		30		
		CSP, VCC = 3.3V, single channel		35		
Thermal Shutdown and Recovery						
Shutdown temperature ⁽⁵⁾	T _{STD}			155		°C
Hysteresis ⁽⁵⁾	T _{HYS}			30		°C
Under-Voltage Lockout (UVLO) Protection						
VCC under-voltage lockout threshold	V _{CC UVLO}	UVLO rising threshold		1.7	1.85	V
UVLO hysteresis	V _{UVLOHYS}			100		mV
Soft Start (SS)						
Vo rise time	T _{SS}	Vo = 3.6V, 10% to 90%		30		μs
EN turn on time	T _{DELAY}			30		μs
Enable (ENx)						
EN rising threshold	V _{ENH}			1	1.2	V
EN hysteresis	V _{ENHYS}			200		mV
EN resistance		Between EN and GND		1		MΩ
ILIM						
Current limit ⁽⁵⁾	I _{LIM}	TQFN package, VCC = 5V, T _J = 25°C	3.2	3.6		A
		CSP package, VCC = 5V, T _J = 25°C	2.1	2.5		A
Hiccup on time	T _{ON}			2		ms
Hiccup off time	T _{OFF}			90		ms
Discharge Resistance (Single Channel)						
Resistance	R _{DIS}			50		Ω

NOTE:

7) Guaranteed by characterization, not tested in production.

TYPICAL PERFORMANCE CHARACTERISTICS

V_{IN} = 3.6V, V_{CC} = 3.6V, T_A = 25°C, unless otherwise noted.

R_{DS(ON)} vs. V_{CC} (CSP)

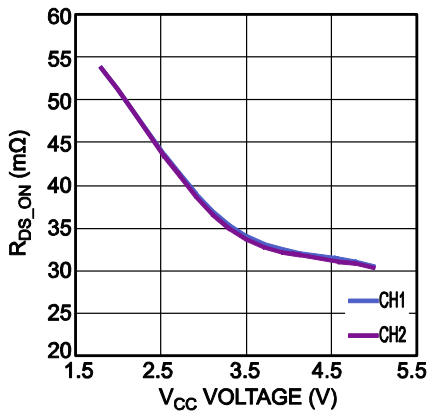

R_{DS(ON)} vs. V_{CC} (TQFN)

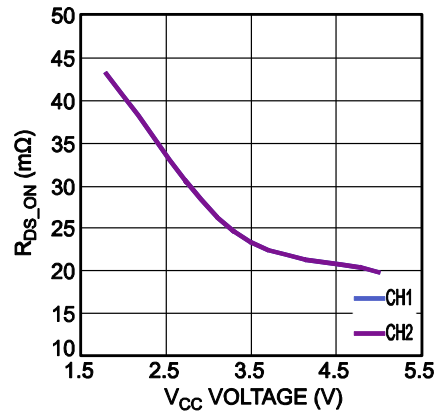

EN Rising Threshold

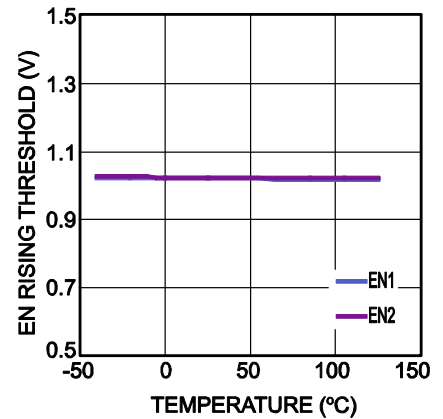

EN Falling Threshold

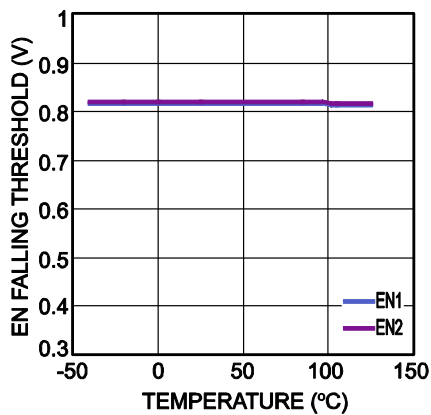

V_{CC} Rising Threshold

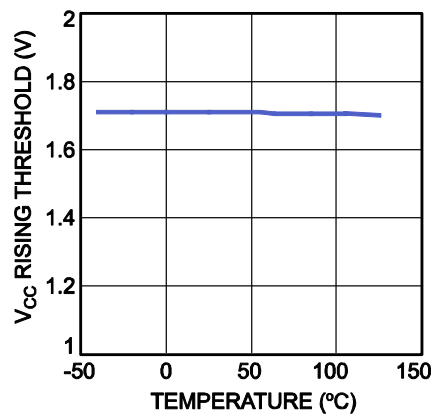

V_{CC} Falling Threshold

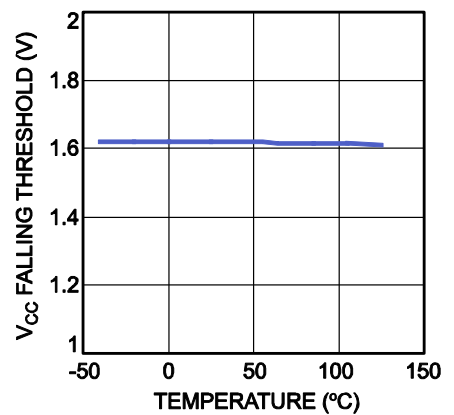

TYPICAL PERFORMANCE CHARACTERISTICS (continued)

V_{IN} = 3.6V, V_{CC} = 3.6V, T_A = 25°C, for MP5090GQHT, unless otherwise noted.

V_{IN} Start-Up
with No Load

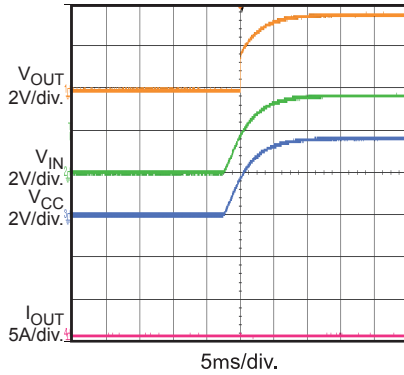

V_{IN} Shutdown
with No Load

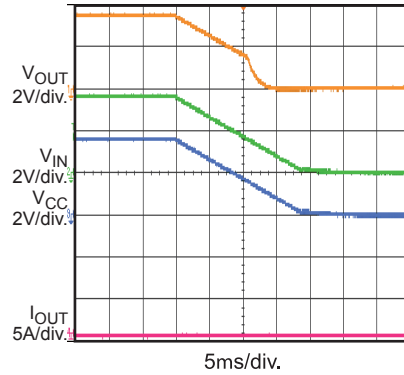

V_{IN} Start-Up
with 3A Load

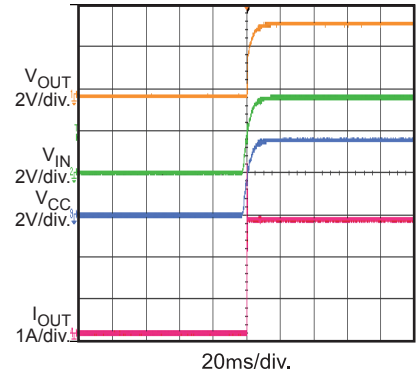

V_{IN} Shutdown
with 3A Load

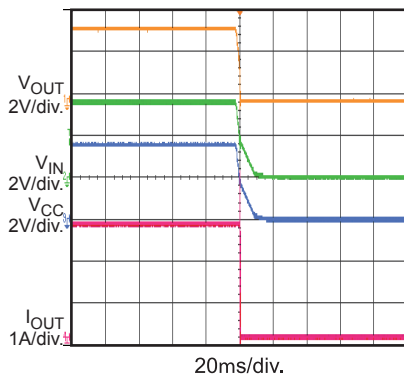

EN Start-Up
with No Load

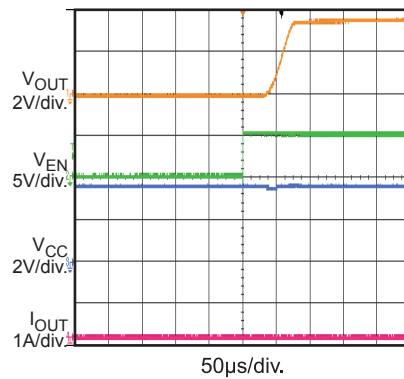

EN Shutdown
with No Load

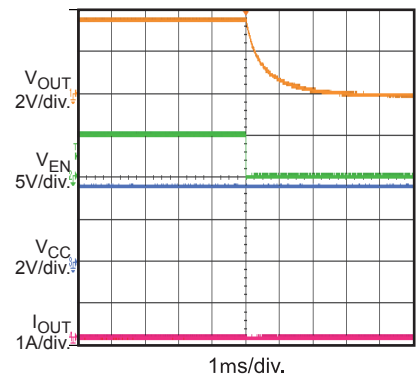

EN Start-Up
with 3A Load

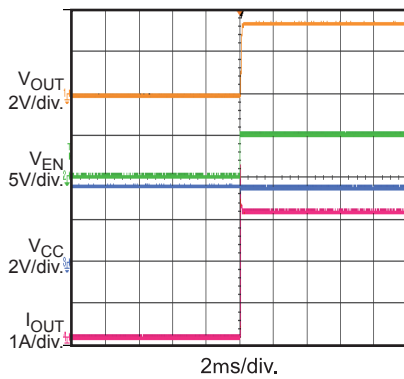

EN Shutdown
with 3A Load

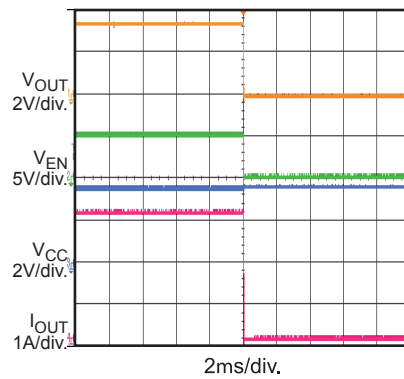

Short Enter

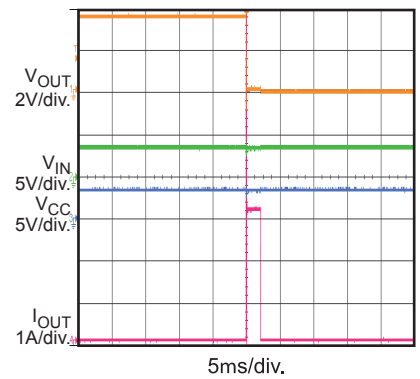

TYPICAL PERFORMANCE CHARACTERISTICS (continued)

V_{IN} = 3.6V, V_{CC} = 3.6V, T_A = 25°C, for MP5090GQHT, unless otherwise noted.

Short Steady State

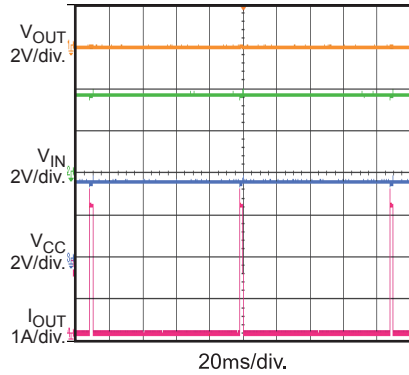

Short Recovery

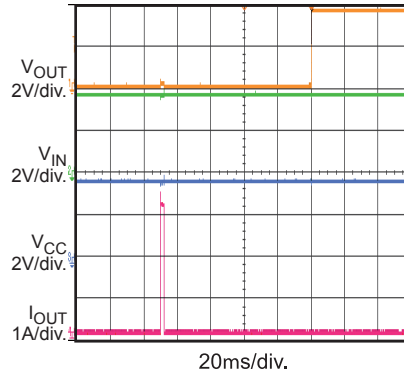

V_{IN} Start-Up with Short

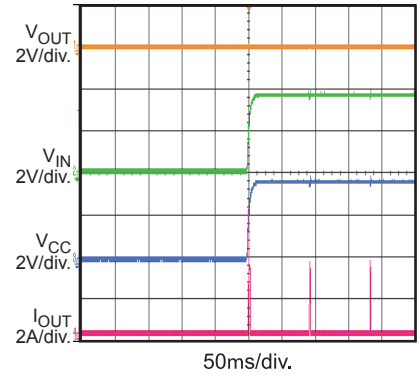

V_{IN} Shutdown with Short

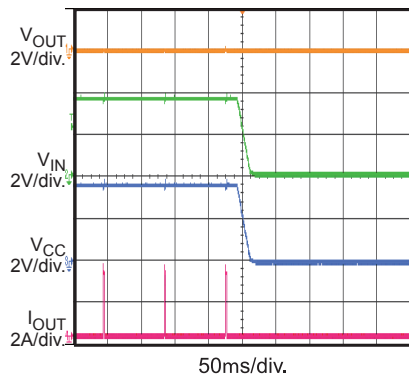

EN Start-Up with Short

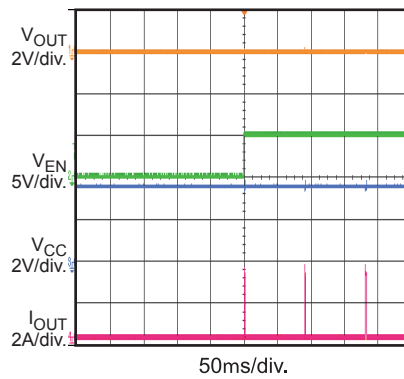

EN Shutdown with Short

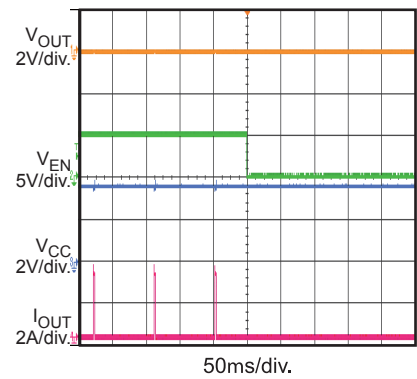

Short Enter (Parallel)

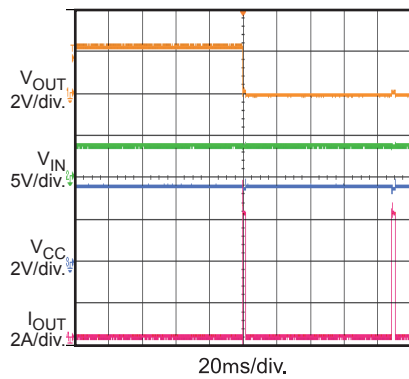

Short Steady (Parallel)

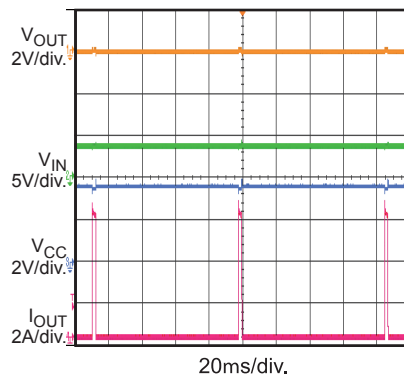

Short Recovery (Parallel)

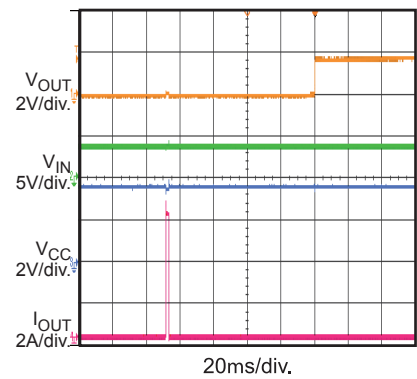

PIN FUNCTIONS

Package Pin #		Name	Description
TQFN	CSP		
1	A1	IN1	Input power supply of switch 1.
2	B1	OUT1	Output to the load of switch 1.
3	C1	OUT2	Output to the load of switch 2.
4	D1	IN2	Input power supply of switch 2.
5	D2	EN2	Enable input of switch 2. Pull EN2 below the specified threshold to shut the chip down.
6	C2	EN1	Enable input of switch 1. Pull EN1 below the specified threshold to shut the chip down.
7	B2	GND	Ground.
8	A2	VCC	Load switch supply voltage to the control circuitry.

BLOCK DIAGRAM

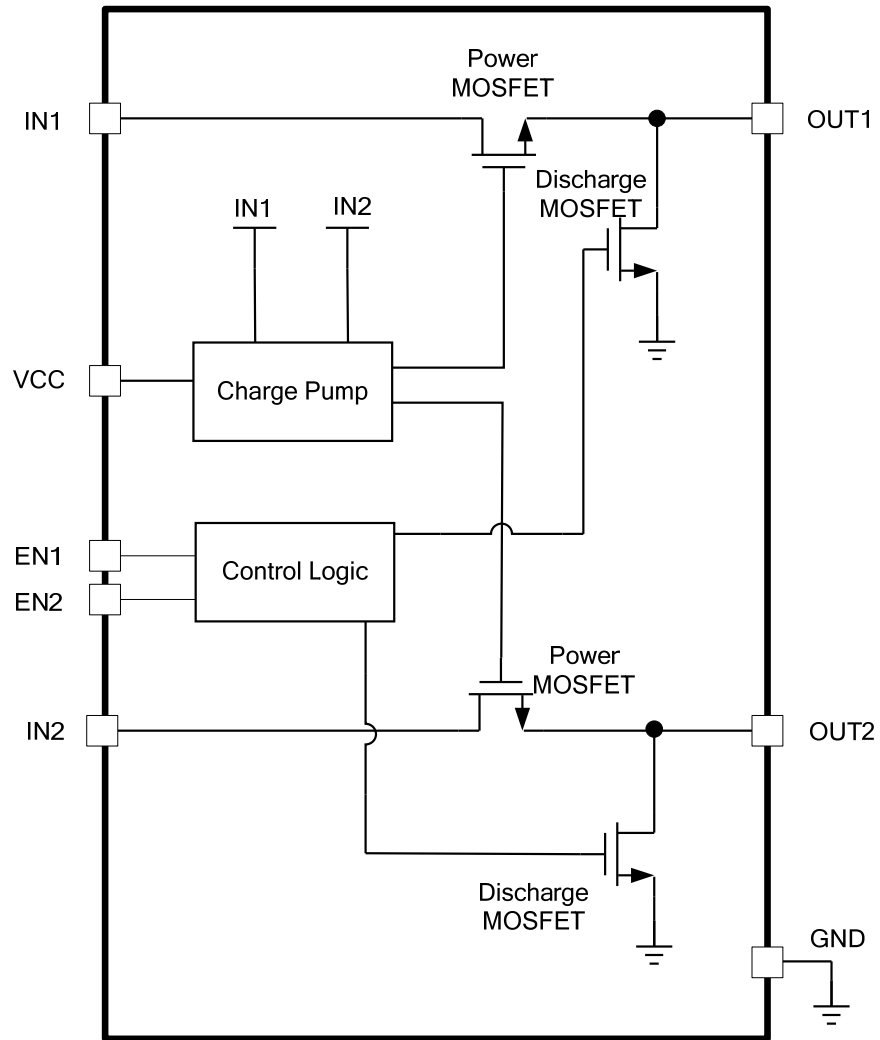

Figure 1: Functional Block Diagram

OPERATION

The MP5090 is designed to limit the inrush current to the load when a circuit card is inserted into a live backplane power source, thereby limiting the backplane's voltage drop and the slew rate of the voltage to the load. The MP5090 integrates dual load switches. Each channel can provide 3A of current (for the MP5090GQHT. The CSP package (MP5090GC) can provide 2A of load capability. The MP5090 can also easily parallel both channels connected together to achieve a maximum 6A load for the MP5090GQHT. The CSP package, MP5090GC, can achieve 4A if the parallel is used.

Enable (EN1, EN2)

When the input voltage is greater than the under-voltage lockout threshold (UVLO) (typically 0.5V), and VCC is higher than 1.85V, the MP5090 can be enabled by pulling EN above 1.2V. Pull EN to ground to disable the MP5090. The recommended start-up sequence is to power up VCC and V_{IN} first. After they are ready, pull the EN voltage high.

Short-Circuit Protection (SCP)

If the load current increases rapidly due to a short circuit, the current may exceed the current limit threshold greatly before the control loop can respond. If the current reaches an internal secondary current limit level (about 5A), a fast turn-off circuit activates to turn off the power MOSFET. This limits the peak current through the switch to limit the input voltage drop. The total short-circuit response time is about 200ns. Fast off keeps the power MOSFET off for about 80µs before turning it back on.

If the current limit block starts to regulate the output current, the power loss on the power MOSFET causes the IC temperature to rise. Hiccup protection limits the current for 2ms and turns it off for another 90ms for the thermal sink. If the junction temperature rises high enough during the hiccup on time, thermal shutdown is triggered. After thermal shutdown, the output is disabled until the over temperature fault is removed. The over-temperature threshold is 155°C, and the hysteresis is 30°C.

Output Discharge

The MP5090 has an output discharge function. The output discharge resistor is active when EN or VCC is low. This function can discharge V_o by pulling down the resistance internally when the IC is disabled and the load is very light.

APPLICATION INFORMATION

Selecting the VCC Capacitor

VCC is an internal load switch supply voltage to the control circuitry. Use low ESR capacitors for the best performance. Ceramic capacitors with X5R or X7R dielectrics are highly recommended because of their low ESR and small temperature coefficients. For most applications, a 1 μ F capacitor is sufficient.

Selecting the Input and Output Capacitor

The input capacitor is very important for protecting the part from input voltage spikes when a dead short or V_{IN} hot-plug occurs. 0805 ceramic capacitors with X5R or X7R dielectrics are highly recommended because of their low ESR and small temperature coefficients. For most applications, a 10 μ F 0805 input capacitor and a 1 μ F 0603 output capacitor are sufficient for each channel. For high output voltage applications, a 22 μ F input capacitor for each channel is recommended.

Reverse Current Block Usage

The dual-channel load switch can be combined into a single-channel load switch with a reverse current block function (see Figure 2). IN1 is the input port, and IN2 is the output port. When EN1 = EN2 = high, the internal MOSFET is on. When EN1 = EN2 = low, the internal MOSFET is off, and the body diode blocks the reverse current.

Parallel Channel Usage

The MP5090 can be parallel-connected to achieve a 6A single-load switch for the MP5090GQHT. The CSP package, MP5090GC, can achieve 4A (see Figure 3). In this parallel connection, IN1 is connected to IN2 externally, and OUT1 is connected to OUT2 externally.

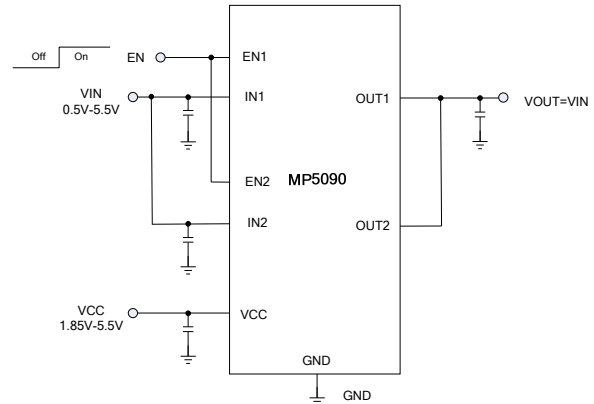

Figure 3: Parallel Channel Usage

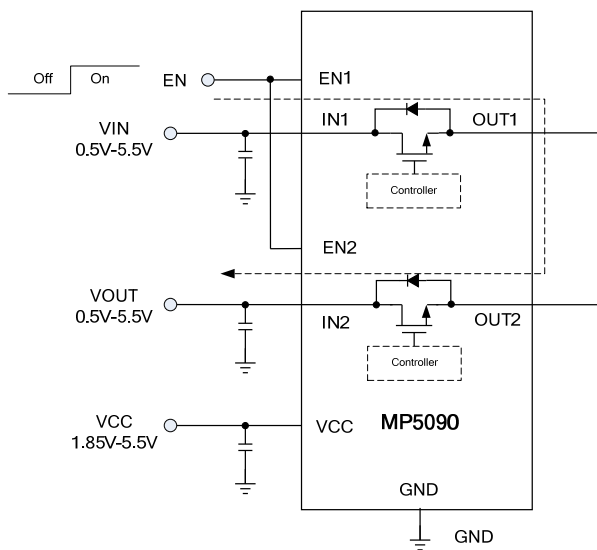
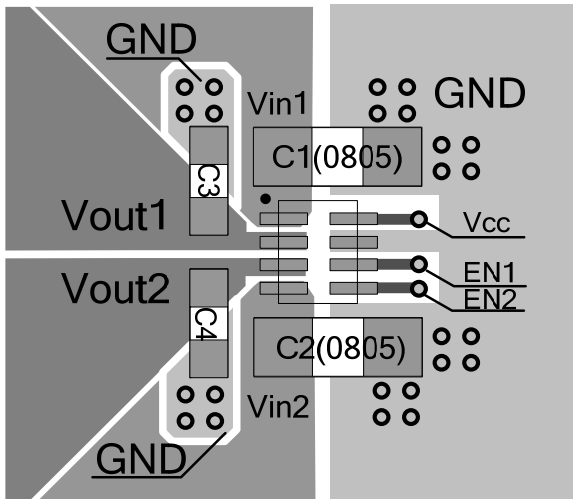

Figure 2: Reverse Current Block Usage

PCB Layout Guidelines

Efficient PCB layout is critical for stable operation. For best results, refer to Figure 4 and follow the guidelines below.

1. Place the caps close to the pins.
2. Place enough vias around the IC to achieve better thermal performance.



Top Layer (TQFN)

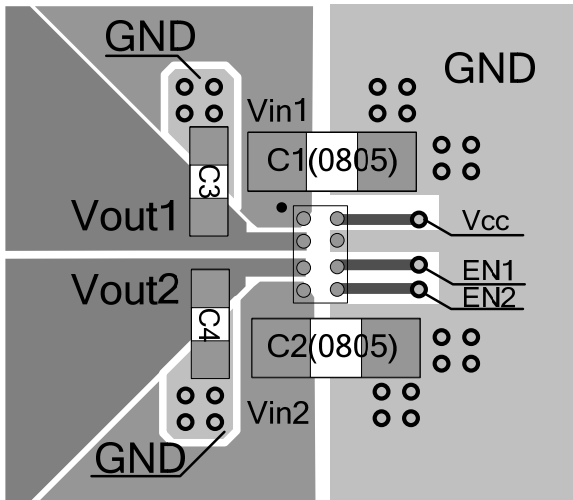

Top Layer (CSP)

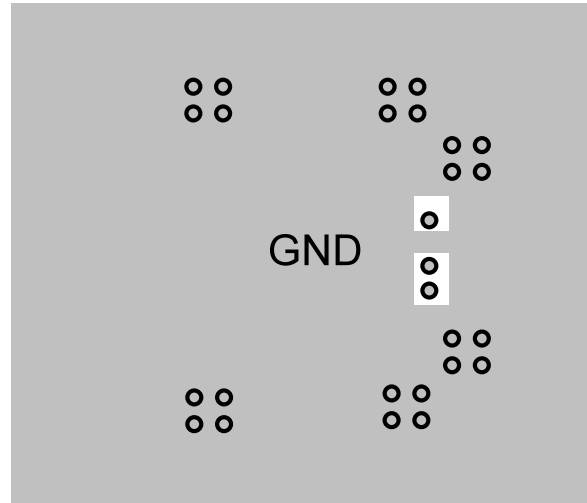

Bottom Layer

Figure 4: Recommended Layout

TYPICAL APPLICATION CIRCUIT

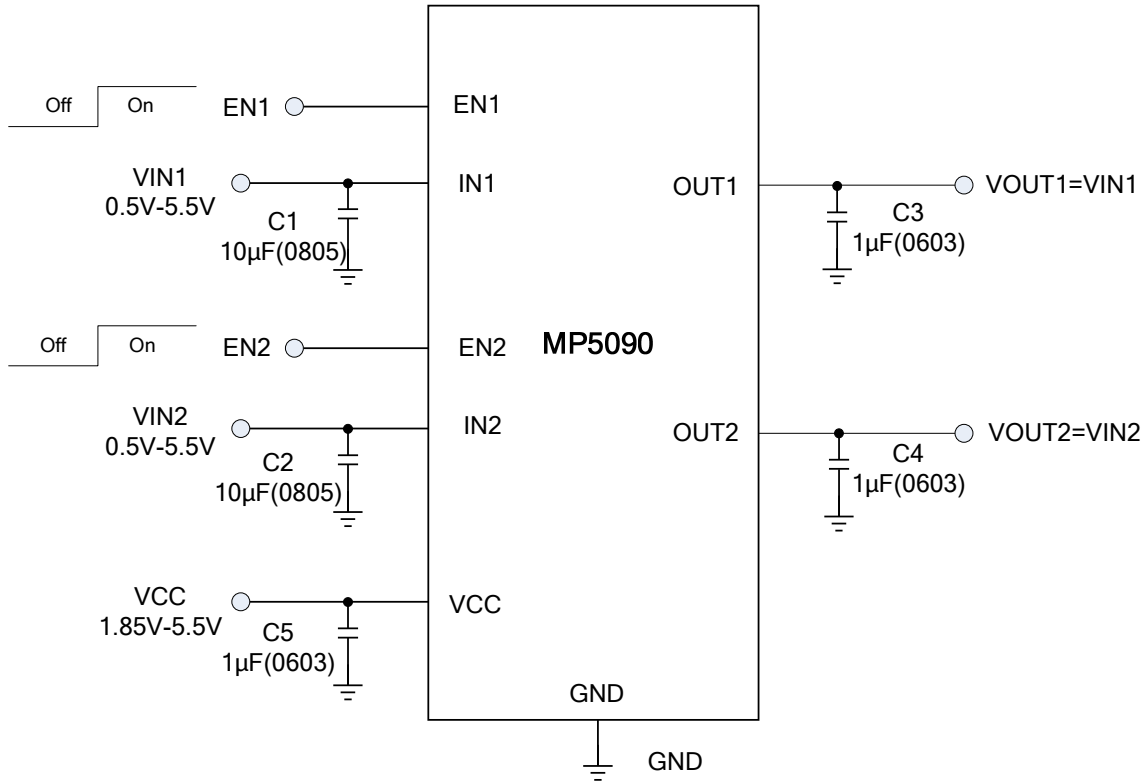
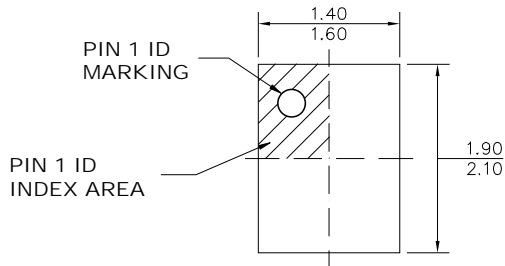

Figure 5: Typical Application Schematic

PACKAGE INFORMATION

TQFN (1.5mmx2.0mm)



TOP VIEW

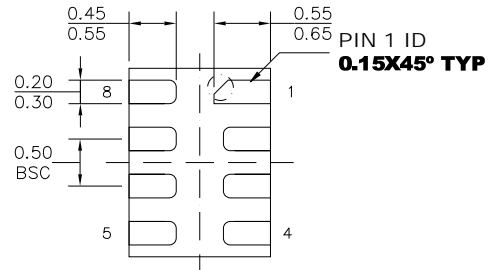

BOTTOM VIEW

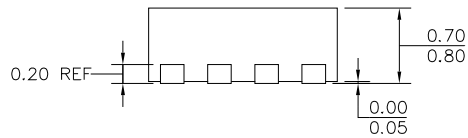

SIDE VIEW

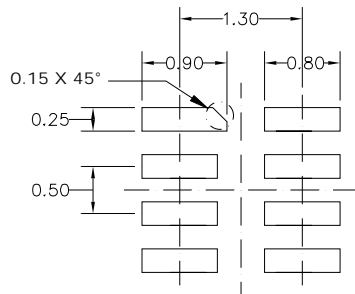

RECOMMENDED LAND PATTERN

NOTE:

- 1) ALL DIMENSIONS ARE IN MILLIMETERS.
- 2) LEAD COPLANARITY SHALL BE 0.10 MILLIMETERS MAX.
- 3) JEDEC REFERENCE IS MO-220.
- 4) DRAWING IS NOT TO SCALE.

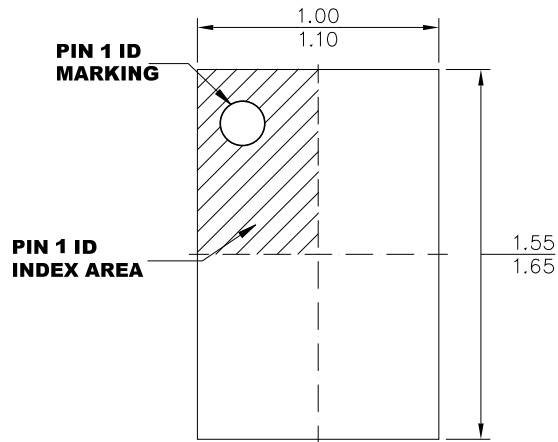
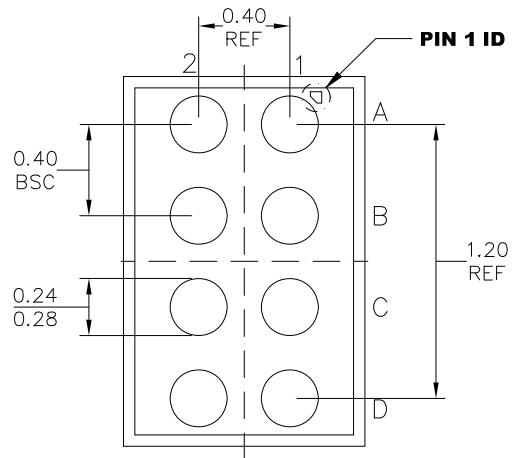
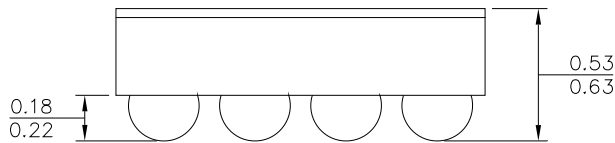
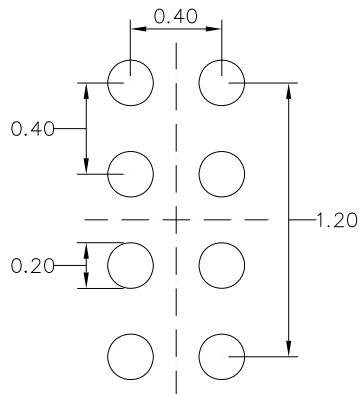

PACKAGE INFORMATION (continued)
CSP (1.05mmx1.60mm)

TOP VIEW

BOTTOM VIEW

SIDE VIEW

RECOMMENDED LAND PATTERN
NOTE:

- 1) ALL DIMENSIONS ARE IN MILLIMETERS.
- 2) BALL COPLANARITY SHALL BE 0.05 MILLIMETER MAX.
- 3) JEDEC REFERENCE IS MO-211.
- 4) DRAWING IS NOT TO SCALE.

NOTICE: The information in this document is subject to change without notice. Users should warrant and guarantee that third party Intellectual Property rights are not infringed upon when integrating MPS products into any application. MPS will not assume any legal responsibility for any said applications.

Looking for pricing, stock, or lifecycle information?

Click below to explore more details on WIN SOURCE:

-  [View MP5090GC-Z on WIN SOURCE](#)
-  [Monolithic Power Systems Inc. Information](#)

Optimize Your Supply Chain with WIN SOURCE Solutions

-  Global Sourcing Solution
-  Obsolete Management
-  Cost Control Management
-  Shortage Management
-  Alternative Solution
-  Excess Inventory Management