



THE DATASHEET OF MOC8204



4N38M, H11D1M, H11D2M, H11D3M, MOC8204M High Voltage Phototransistor Optocouplers

Features

- High voltage:
 - MOC8204M, $BV_{CER} = 400V$
 - H11D1M, H11D2M, $BV_{CER} = 300V$
 - H11D3M, $BV_{CER} = 200V$
- High isolation voltage:
 - 7500 V_{AC} peak, 1 second
- Underwriters Laboratory (UL) recognized
File # E90700, Volume 2
- IEC 60747-5-2 approved (ordering option V)

Applications

- Power supply regulators
- Digital logic inputs
- Microprocessor inputs
- Appliance sensor systems
- Industrial controls

General Description

The 4N38M, H11DXM and MOC8204M are phototransistor-type optically coupled optoisolators. A gallium arsenide infrared emitting diode is coupled with a high voltage NPN silicon phototransistor. The device is supplied in a standard plastic six-pin dual-in-line package.

Schematic

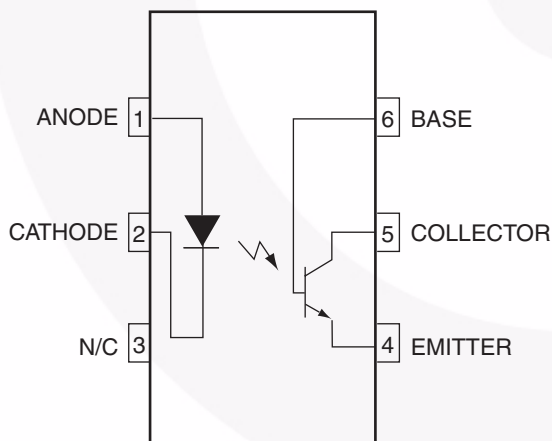

Package Outlines

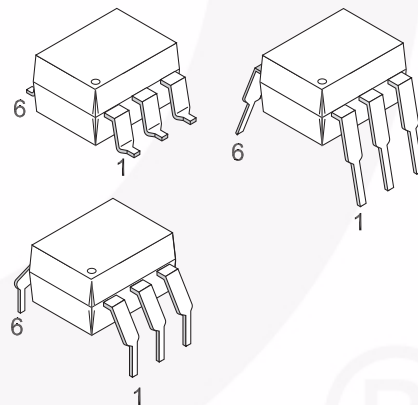

Absolute Maximum Ratings

Stresses exceeding the absolute maximum ratings may damage the device. The device may not function or be operable above the recommended operating conditions and stressing the parts to these levels is not recommended. In addition, extended exposure to stresses above the recommended operating conditions may affect device reliability. The absolute maximum ratings are stress ratings only.

Symbol	Parameter	Device	Value	Units
TOTAL DEVICE				
T _{STG}	Storage Temperature	All	-40 to +150	°C
T _{OPR}	Operating Temperature	All	-40 to +100	°C
T _{SOL}	Lead Solder Temperature (Wave Solder)	All	260 for 10 sec	°C
P _D	Total Device Power Dissipation @ T _A = 25°C Derate Above 25°C	All	260	mW
			3.5	mW/°C
EMITTER				
I _F	Forward DC Current ⁽¹⁾	All	80	mA
V _R	Reverse Input Voltage ⁽¹⁾	All	6.0	V
I _{F(pk)}	Forward Current – Peak (1µs pulse, 300pps) ⁽¹⁾	All	3.0	A
P _D	LED Power Dissipation @ T _A = 25°C ⁽¹⁾ Derate Above 25°C	All	150	mW
			1.41	mW/°C
DETECTOR				
P _D	Power Dissipation @ T _A = 25°C Derate linearly above 25°C	All	300	mW
			4.0	mW/°C
V _{CER}	Collector to Emitter Voltage ⁽¹⁾	MOC8204M	400	V
		H11D1M, H11D2M	300	
		H11D3M	200	
		4N38M	80	
V _{CBO}	Collector Base Voltage ⁽¹⁾	MOC8204M	400	V
		H11D1M, H11D2M	300	
		H11D3M	200	
		4N38M	80	
V _{ECO}	Emitter to Collector Voltage ⁽¹⁾	H11D1M, H11D2M, H11D3M, MOC8204M	7	V
I _C	Collector Current (Continuous)	All	100	mA

Note:

- Parameters meet or exceed JEDEC registered data (for 4N38M only).

Electrical Characteristics (T_A = 25°C unless otherwise specified.)

Individual Component Characteristics

Symbol	Characteristic	Test Conditions	Device	Min.	Typ.*	Max.	Unit
EMITTER							
V _F	Forward Voltage ⁽²⁾	I _F = 10mA	All		1.15	1.5	V
$\frac{\Delta V_F}{\Delta T_A}$	Forward Voltage Temp. Coefficient		All		-1.8		mV/°C
BV _R	Reverse Breakdown Voltage	I _R = 10μA	All	6	25		V
C _J	Junction Capacitance	V _F = 0V, f = 1MHz	All		50		pF
		V _F = 1V, f = 1MHz			65		pF
I _R	Reverse Leakage Current ⁽²⁾	V _R = 6V	All		0.05	10	μA
DETECTOR							
BV _{CER}	Breakdown Voltage Collector to Emitter ⁽²⁾	R _{BE} = 1MΩ, I _C = 1.0mA, I _F = 0	MOC8204M	400			V
			H11D1M/2M	300			
			H11D3M	200			
BV _{CEO}		No RBE, I _C = 1.0mA	4N38M	80			
BV _{CBO}	Collector to Base ⁽²⁾	I _C = 100μA, I _F = 0	MOC8204M	400			V
			H11D1M/2M	300			
			H11D3M	200			
			4N38M	80			
BV _{EBO}	Emitter to Base	I _E = 100μA, I _F = 0	4N38M	7			V
BV _{ECO}	Emitter to Collector	I _E = 100μA, I _F = 0	All	7	10		V
I _{CER}	Leakage Current Collector to Emitter ⁽²⁾ (R _{BE} = 1MΩ)	V _{CE} = 300V, I _F = 0, T _A = 25°C	MOC8204M			100	nA
		V _{CE} = 300V, I _F = 0, T _A = 100°C				250	μA
		V _{CE} = 200V, I _F = 0, T _A = 25°C	H11D1M/2M			100	nA
		V _{CE} = 200V, I _F = 0, T _A = 100°C				250	μA
		V _{CE} = 100V, I _F = 0, T _A = 25°C	H11D3M			100	nA
		V _{CE} = 100V, I _F = 0, T _A = 100°C				250	μA
I _{CEO}		No RBE, V _{CE} = 60V, I _F = 0, T _A = 25°C	4N38M			50	nA

Transfer Characteristics (T_A = 25°C Unless otherwise specified.)

Symbol	Characteristics	Test Conditions	Device	Min.	Typ.*	Max.	Units
EMITTER							
CTR	Current Transfer Ratio, Collector to Emitter	I _F = 10mA, V _{CE} = 10V, R _{BE} = 1MΩ	H11D1M/2M/3M, MOC8204M	2 (20)			mA (%)
		I _F = 10mA, V _{CE} = 10V	4N38M	2 (20)			
V _{CE(SAT)}	Saturation Voltage ⁽²⁾	I _F = 10mA, I _C = 0.5mA, R _{BE} = 1MΩ	H11D1M/2M/3M, MOC8204M		0.1	0.40	V
		I _F = 20mA, I _C = 4mA	4N38M			1.0	
SWITCHING TIMES							
t _{ON}	Non-Saturated Turn-on Time	V _{CE} = 10V, I _{CE} = 2mA, R _L = 100Ω	All		5		μs
t _{OFF}	Turn-off Time		All		5		μs

*All Typical values at T_A = 25°C

Note:

2. Parameters meet or exceed JEDEC registered data (for 4N38M only).

DC Electrical Characteristics (Continued) ($T_A = 25^\circ\text{C}$ unless otherwise specified.)

Isolation Characteristics

Symbol	Characteristic	Test Conditions	Device	Min.	Typ.*	Max.	Units
V_{ISO}	Isolation Voltage	$f = 60\text{Hz}, t = 1 \text{ sec.}$	All	7500			V_{ACPEAK}
R_{ISO}	Isolation Resistance	$V_{I-O} = 500 \text{ VDC}$	All	10^{11}			Ω
C_{ISO}	Isolation Capacitance	$f = 1\text{MHz}$	All		0.2		pF

*All Typical values at $T_A = 25^\circ\text{C}$



Typical Performance Curves

Fig. 1 LED Forward Voltage vs. Forward Current

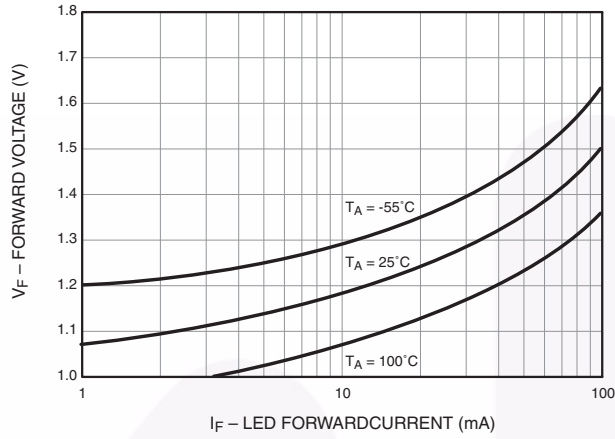

Fig. 2 Normalized Output Characteristics

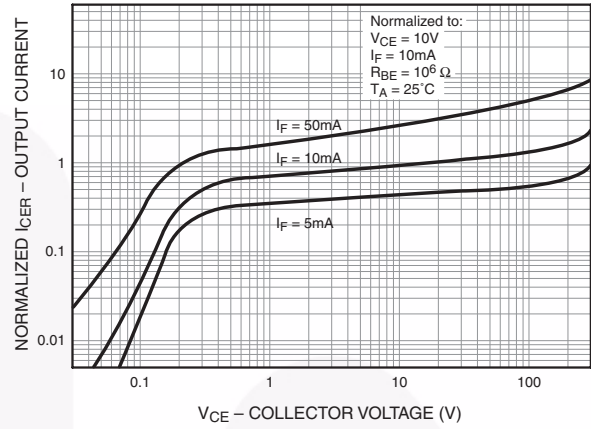

Fig. 3 Normalized Output Current vs. LED Input Current

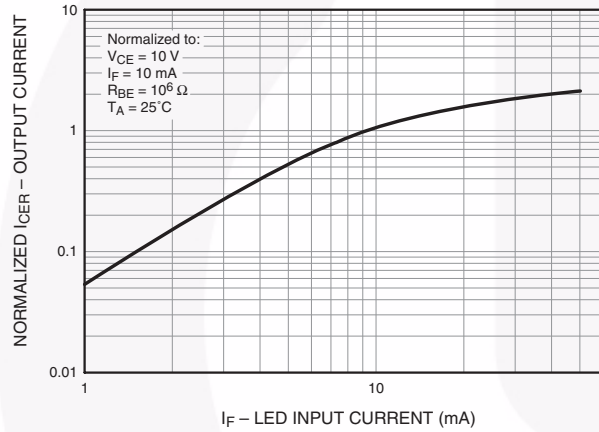

Fig. 4 Normalized Output Current vs. Temperature

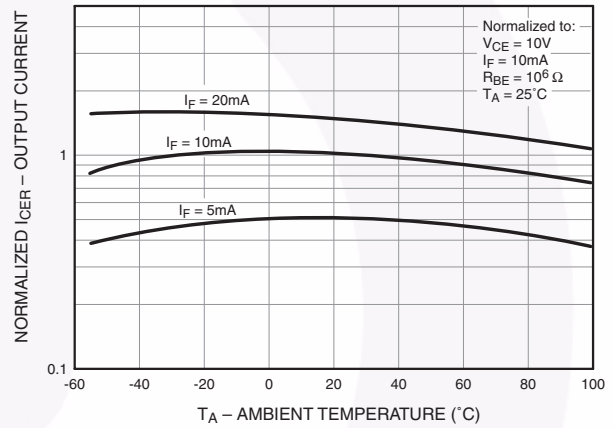

Fig. 5 Normalized Dark Current vs. Ambient Temperature

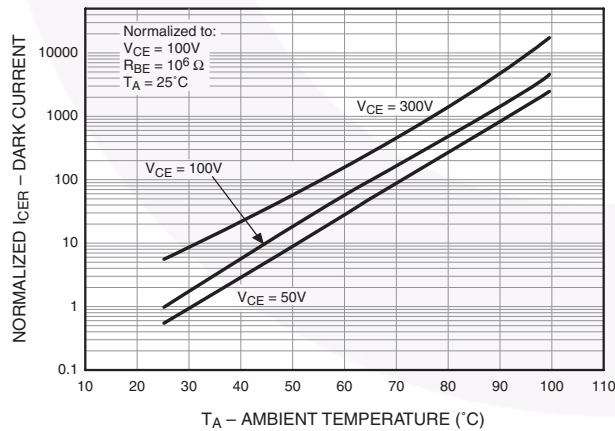
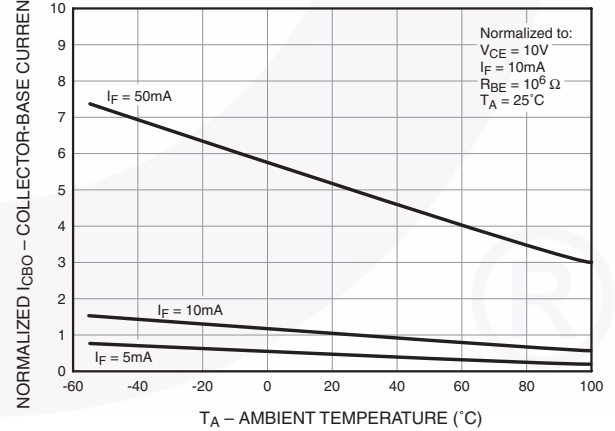
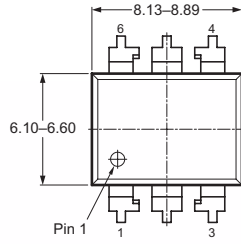

Fig. 6 Normalized Collector-Base Current vs. Temperature



Package Dimensions

Through Hole



0.4" Lead Spacing

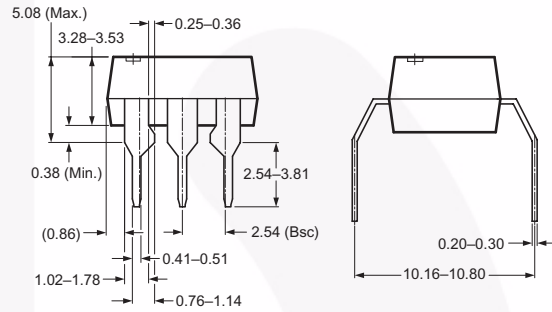
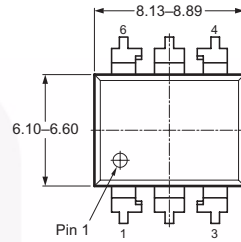

Surface Mount

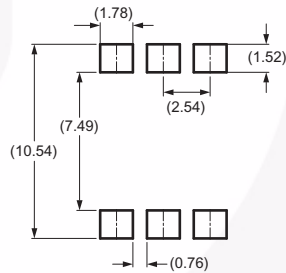
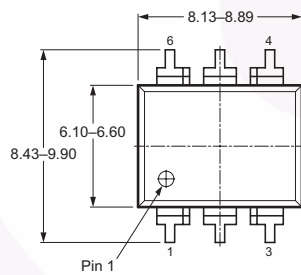

Recommended Pad Layout

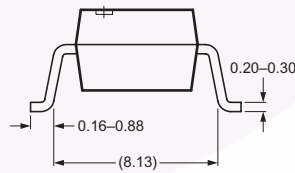

Note:
All dimensions in mm.

Ordering Information

Option	Order Entry Identifier (Example)	Description
No option	H11D1M	Standard Through Hole Device (50 units per tube)
S	H11D1SM	Surface Mount Lead Bend
SR2	H11D1SR2M	Surface Mount; Tape and Reel
T	H11D1TM	0.4" Lead Spacing
V	H11D1VM	VDE 0884
TV	H11D1TVM	VDE 0884, 0.4" Lead Spacing
SV	H11D1SVM	VDE 0884, Surface Mount
SR2V	H11D1SR2VM	VDE 0884, Surface Mount, Tape and Reel

Marking Information

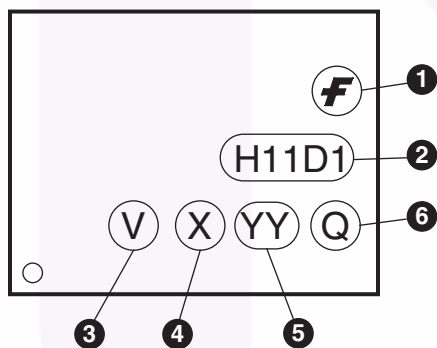

Definitions	
1	Fairchild logo
2	Device number
3	VDE mark (Note: Only appears on parts ordered with VDE option – See order entry table)
4	One digit year code, e.g., '7'
5	Two digit work week ranging from '01' to '53'
6	Assembly package code



TRADEMARKS

The following includes registered and unregistered trademarks and service marks, owned by Fairchild Semiconductor and/or its global subsidiaries, and is not intended to be an exhaustive list of all such trademarks.

- | | | | |
|---|---|---|---|
| Build it Now™ | FRFET® | Programmable Active Droop™ | the power franchise |
| CorePLUS™ | Global Power Resource SM | QFET® | TinyBoost™ |
| CorePOWER™ | Green FPS™ | QS™ | TinyBuck™ |
| CROSSVOLT™ | Green FPS™ e-Series™ | Quiet Series™ | TinyLogic® |
| CTL™ | GTO™ | RapidConfigure™ | TINYOPTO™ |
| Current Transfer Logic™ | IntelliMAX™ |  ™ | TinyPower™ |
| EcoSPARK® | ISOPLANAR™ | Saving our world, 1mW/W/kW at a time™ | TinyPWM™ |
| EfficientMax™ | MegaBuck™ | SmartMax™ | TinyWire™ |
| EZSWITCH™ * | MICROCOUPLER™ | SMART START™ | TriFault Detect™ |
|  ™ | MicroFET™ | SPM® | µSerDes™ |
|  ® | MicroPak™ | STEALTH™ |  ™ |
| Fairchild® | MillerDrive™ | SuperFET™ | UHC® |
| Fairchild Semiconductor® | MotionMax™ | SuperSOT™-3 | Ultra FRFET™ |
| FACT Quiet Series™ | Motion-SPM™ | SuperSOT™-6 | UnifET™ |
| FACT® | OPTOLOGIC® | SuperSOT™-8 | VCX™ |
| FAST® | OPTOPLANAR® | SupreMOS™ | VisualMax™ |
| FastvCore™ |  ™ | SyncFET™ | XS™ |
| FlashWriter® * | PDP SPM™ |  ™ | |
| FPS™ | Power-SPM™ | The Power Franchise® | |
| F-PFS™ | PowerTrench® | | |
| | PowerXS™ | | |

* EZSWITCH™ and FlashWriter® are trademarks of System General Corporation, used under license by Fairchild Semiconductor.

DISCLAIMER

FAIRCHILD SEMICONDUCTOR RESERVES THE RIGHT TO MAKE CHANGES WITHOUT FURTHER NOTICE TO ANY PRODUCTS HEREIN TO IMPROVE RELIABILITY, FUNCTION, OR DESIGN. FAIRCHILD DOES NOT ASSUME ANY LIABILITY ARISING OUT OF THE APPLICATION OR USE OF ANY PRODUCT OR CIRCUIT DESCRIBED HEREIN; NEITHER DOES IT CONVEY ANY LICENSE UNDER ITS PATENT RIGHTS, NOR THE RIGHTS OF OTHERS. THESE SPECIFICATIONS DO NOT EXPAND THE TERMS OF FAIRCHILD'S WORLDWIDE TERMS AND CONDITIONS, SPECIFICALLY THE WARRANTY THEREIN, WHICH COVERS THESE PRODUCTS.

LIFE SUPPORT POLICY

FAIRCHILD'S PRODUCTS ARE NOT AUTHORIZED FOR USE AS CRITICAL COMPONENTS IN LIFE SUPPORT DEVICES OR SYSTEMS WITHOUT THE EXPRESS WRITTEN APPROVAL OF FAIRCHILD SEMICONDUCTOR CORPORATION.

As used herein:

- Life support devices or systems are devices or systems which, (a) are intended for surgical implant into the body or (b) support or sustain life, and (c) whose failure to perform when properly used in accordance with instructions for use provided in the labeling, can be reasonably expected to result in a significant injury of the user.
- A critical component in any component of a life support, device, or system whose failure to perform can be reasonably expected to cause the failure of the life support device or system, or to affect its safety or effectiveness.

ANTI-COUNTERFEITING POLICY

Fairchild Semiconductor Corporation's Anti-Counterfeiting Policy. Fairchild's Anti-Counterfeiting Policy is also stated on our external website, www.fairchildsemi.com, under Sales Support.

Counterfeiting of semiconductor parts is a growing problem in the industry. All manufacturers of semiconductor products are experiencing counterfeiting of their parts. Customers who inadvertently purchase counterfeit parts experience many problems such as loss of brand reputation, substandard performance, failed applications, and increased cost of production and manufacturing delays. Fairchild is taking strong measures to protect ourselves and our customers from the proliferation of counterfeit parts. Fairchild strongly encourages customers to purchase Fairchild parts either directly from Fairchild or from Authorized Fairchild Distributors who are listed by country on our web page cited above. Products customers buy either from Fairchild directly or from Authorized Fairchild Distributors are genuine parts, have full traceability, meet Fairchild's quality standards for handling and storage and provide access to Fairchild's full range of up-to-date technical and product information. Fairchild and our Authorized Distributors will stand behind all warranties and will appropriately address any warranty issues that may arise. Fairchild will not provide any warranty coverage or other assistance for parts bought from Unauthorized Sources. Fairchild is committed to combat this global problem and encourage our customers to do their part in stopping this practice by buying direct or from authorized distributors.

PRODUCT STATUS DEFINITIONS

Definition of Terms

Datasheet Identification	Product Status	Definition
Advance Information	Formative / In Design	Datasheet contains the design specifications for product development. Specifications may change in any manner without notice.
Preliminary	First Production	Datasheet contains preliminary data; supplementary data will be published at a later date. Fairchild Semiconductor reserves the right to make changes at any time without notice to improve design.
No Identification Needed	Full Production	Datasheet contains final specifications. Fairchild Semiconductor reserves the right to make changes at any time without notice to improve the design.
Obsolete	Not In Production	Datasheet contains specifications on a product that is discontinued by Fairchild Semiconductor. The datasheet is for reference information only.

Rev. 138

Looking for pricing, stock, or lifecycle information?

Click below to explore more details on WIN SOURCE:

 [View MOC8204](#) on WIN SOURCE

 [ON Semiconductor](#) Information

Optimize Your Supply Chain with WIN SOURCE Solutions

-  Global Sourcing Solution
-  Obsolete Management
-  Cost Control Management
-  Shortage Management
-  Alternative Solution
-  Excess Inventory Management