



**THE DATASHEET OF  
BCM43362KUBG**



# Single-Chip IEEE 802.11™ b/g/n MAC/Baseband/Radio

The Cypress CYW43362 single-chip device provides the highest level of integration for Internet of Things applications and handheld wireless systems, featuring integrated IEEE 802.11™ b/g and IEEE 802.11n. It includes a 2.4 GHz WLAN CMOS power amplifier (PA) that meets the output power requirements of most handheld systems. An optional external low-noise amplifier (LNA) and external PA are also supported.

Along with the integrated power amplifier, the CYW43362 also includes integrated transmit and receive baluns, further reducing the overall solution cost.

Host interface options include SDIO v2.0 that can operate in 4b or 1b modes.

Utilizing advanced design techniques and process technology to reduce active and idle power, the CYW43362 is designed to address the needs of highly mobile devices that require minimal power consumption and compact size. It includes a power management unit that simplifies the system power topology and allows for operation directly from a rechargeable mobile platform battery while maximizing battery life.

## Features

- Single-band 2.4 GHz IEEE 802.11 b/g/n
- Integrated WLAN CMOS power amplifier with internal power detector and closed-loop power control
- Internal fractional-N PLL enables the use of a wide range of reference clock frequencies
- Supports IEEE 802.15.2 external 3-wire and 4-wire coexistence schemes to optimize bandwidth utilization with other co-located wireless technologies such as Bluetooth, Zigbee, or BT Smart. Also supports sECI coexistence interface.
- Supports SDIO v2.0 (50 MHz, 4-bit and 1-bit)
- Integrated ARM Cortex™-M3 CPU with on-chip memory enables running IEEE 802.11 firmware that can be field-upgraded with future features.
- Supports WMM®, WMM-PS, and Wi-Fi Voice Personal (upgradable to Voice Enterprise in the future)
- Security:
  - Hardware WAPI acceleration engine
  - AES and TKIP in hardware for faster data encryption and IEEE 802.11i compatibility
  - WPA™- and WPA2™- (Personal) support for powerful encryption and authentication
- Programmable dynamic power management
- Supports battery voltage range from 2.3V to 4.8V supplies with internal switching regulator
- 1 kbit One-Time Programmable (OTP) memory for storing board parameters
- 69-bump WLBGA (4.52 mm x 2.92 mm, 0.4 mm pitch)

Figure 1. CYW43362 System Block Diagram

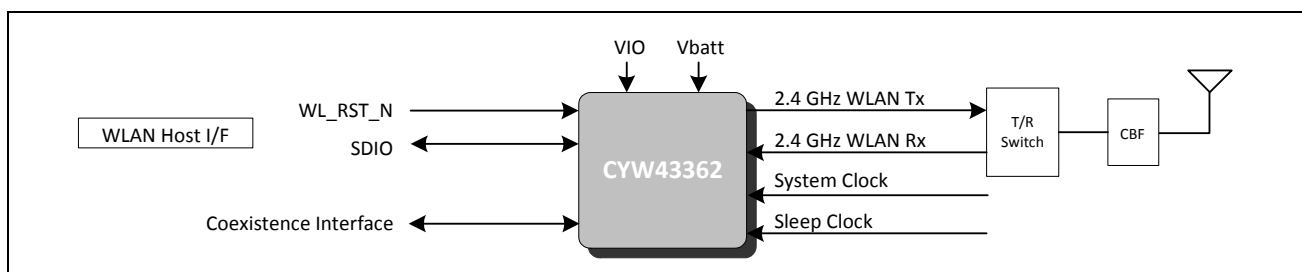

## Introduction

This document provides engineering design information for the CYW43362, a single chip with an integrated 2.4 GHz RF transceiver, MAC, and baseband processor that fully supports the IEEE 802.11™ b/g/n standards.

The information provided is intended for hardware design engineers who will be incorporating the CYW43362 into their designs.

## Cypress part numbering scheme

Cypress is converting the acquired IoT part numbers from Broadcom to the Cypress part numbering scheme. Due to this conversion, there is no change in form, fit, or function as a result of offering the device with Cypress part number marking. The table provides Cypress ordering part number that matches an existing IoT part number.

**Table 1. Mapping Table for Part Number between Broadcom and Cypress**

Broadcom Part Number	Cypress Part Number
BCM43362	CYW43362
BCM43362KUBG	CYW43362KUBG

## IoT Resources

Cypress provides a wealth of data at <http://www.cypress.com/internet-things-iot> to help you to select the right IoT device for your design, and quickly and effectively integrate the device into your design. Cypress provides customer access to a wide range of information, including technical documentation, schematic diagrams, product bill of materials, PCB layout information, and software updates. Customers can acquire technical documentation and software from the Cypress Support Community website (<http://community.cypress.com/>).

## Contents

<b>1. Overview</b> .....	<b>4</b>	<b>8. WLAN Software Architecture</b> .....	<b>22</b>
1.1 Overview .....	4	8.1 Host Software Architecture .....	22
1.2 Standards Compliance .....	5	8.2 Device Software Architecture .....	22
<b>2. Power Supplies and Power Management</b> .....	<b>6</b>	8.2.1 Remote Downloader .....	22
2.1 WLAN Power Management .....	6	8.3 Wireless Configuration Utility .....	23
2.2 Power Supply Topology .....	6	<b>9. Pinout and Signal Descriptions</b> .....	<b>23</b>
2.3 Voltage Regulators .....	7	9.1 Signal Assignments .....	23
2.4 PMU Sequencing .....	7	9.2 WLAN GPIO Signals and Strapping Options .....	31
2.5 Low-Power Shutdown .....	8	<b>10. DC Characteristics</b> .....	<b>32</b>
2.6 CBUCK Regulator Features .....	8	10.1 Absolute Maximum Ratings .....	32
<b>3. Frequency References</b> .....	<b>9</b>	10.2 Environmental Ratings .....	32
3.1 Crystal Interface and Clock Generation .....	9	10.3 Electrostatic Discharge Specifications .....	32
3.2 TCXO .....	9	10.4 Recommended Operating Conditions and DC Characteristics .....	33
3.3 External 32.768 kHz Low-Power Oscillator .....	11	<b>11. WLAN RF Specifications</b> .....	<b>34</b>
<b>4. WLAN System Interfaces</b> .....	<b>12</b>	11.1 2.4 GHz Band General RF Specifications .....	34
4.1 SDIO v2.0 .....	12	11.2 WLAN 2.4 GHz Receiver Performance Specifications .....	34
4.1.1 SDIO Pin Descriptions .....	12	11.3 WLAN 2.4 GHz Transmitter Performance Specifications .....	37
4.2 External Coexistence Interface .....	13	11.4 General Spurious Emissions Specifications .....	38
<b>5. Wireless LAN MAC and PHY</b> .....	<b>15</b>	<b>12. Internal Regulator Electrical Specifications</b> .....	<b>39</b>
5.1 MAC Features .....	15	12.1 Core Buck Regulator .....	39
5.1.1 MAC Description .....	15	12.2 3.3V LDO (LDO3P3) .....	41
5.1.1.1.PSM .....	16	12.3 CLDO .....	41
5.1.1.2.WEP .....	16	12.4 LNLDO1 .....	42
5.1.1.3.TXE .....	16	<b>13. System Power Consumption</b> .....	<b>43</b>
5.1.1.4.RXE .....	16	<b>14. Interface Timing and AC Characteristics</b> .....	<b>44</b>
5.1.1.5.IFS .....	17	14.1 SDIO Default Mode Timing .....	44
5.1.1.6.TSF .....	17	14.2 SDIO High-Speed Mode Timing .....	45
5.1.1.7.NAV .....	17	14.3 JTAG Timing .....	46
5.1.1.8.MAC-PHY Interface .....	17	<b>15. Package Information</b> .....	<b>47</b>
5.2 PHY Description .....	17	15.1 Package Thermal Characteristics .....	47
5.2.1 PHY Features .....	17	15.1.1 Junction Temperature Estimation and PSI Versus $\Theta_{jc}$ .....	47
<b>6. WLAN Radio Subsystem</b> .....	<b>20</b>	<b>16. Mechanical Information</b> .....	<b>48</b>
6.1 Receive Path .....	20	<b>17. Ordering Information</b> .....	<b>49</b>
6.2 Transmit Path .....	20	<b>18. References</b> .....	<b>49</b>
6.3 Calibration .....	20	<b>Document History Page</b> .....	<b>50</b>
<b>7. CPU and Global Functions</b> .....	<b>21</b>	<b>Sales, Solutions, and Legal Information</b> .....	<b>51</b>
7.1 WLAN CPU and Memory Subsystem .....	21		
7.2 One-Time Programmable Memory .....	21		
7.3 GPIO Interface .....	21		
7.4 JTAG Interface .....	21		
7.5 UART Interface .....	21		

# 1. Overview

## 1.1 Overview

The Cypress CYW43362 provides the highest level of integration for a Internet of Things applications and handheld wireless system, with integrated IEEE 802.11 b/g/n. It provides a small form-factor solution with minimal external components to drive down cost for mass volumes and allows for flexibility in size, form, and function. The CYW43362 is designed to address the needs of highly mobile devices that require minimal power consumption and reliable operation.

Figure 2 shows the interconnect of all the major physical blocks in the CYW43362 and their associated external interfaces, which are described in greater detail in the following sections.

Figure 2. CYW43362 Block Diagram

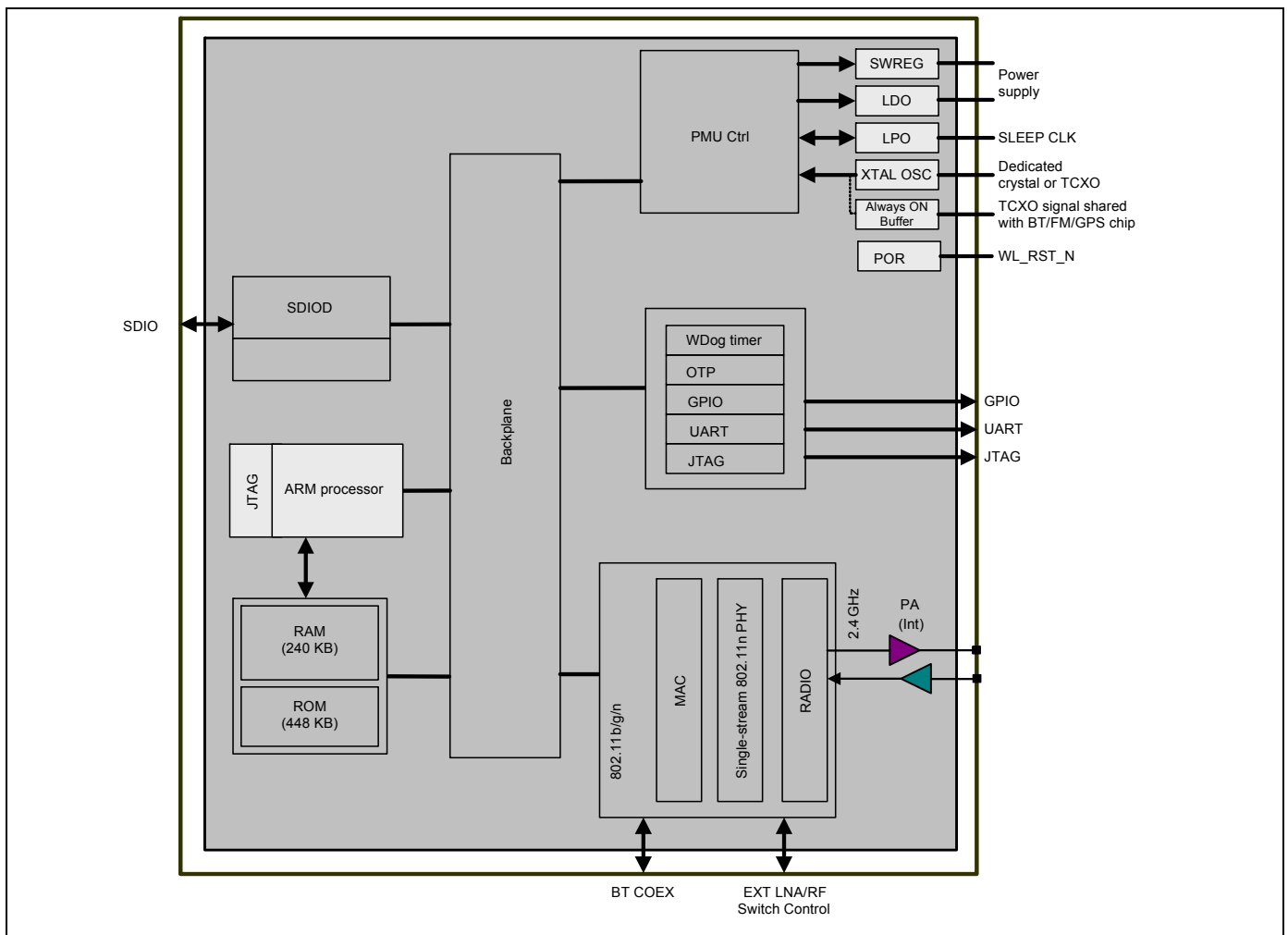

## 1.2 Standards Compliance

The CYW43362 supports the following standards:

- IEEE 802.11n
- 802.11b
- 802.11g
- 802.11d
- 802.11h
- 802.11i
- 802.11j

The CYW43362 will support the following future drafts/standards:

- 802.11w—Secure Management Frames
- 802.11 Extensions:
  - WMM®
  - 802.11i MAC Enhancements
  - 802.11r Fast Roaming Support (between APs)
  - 802.11k Radio Resource Measurement
- Security:
  - WEP
  - WAPI
  - WPA™ Personal
  - WPA2™ Personal
  - AES (Hardware Accelerator)
  - TKIP (HW Accelerator)
  - CKIP (SW Support)
- QOS Protocols:
  - WMM
  - WMM-PS (U-APSD)
  - WMM-SA
- Proprietary Protocols:
  - WFAEC
- Coexistence Interfaces:
  - Supports IEEE 802.15.2 external three-wire coexistence scheme to support additional wireless technologies, such as Bluetooth, Zigbee, or BT Smart.

## 2. Power Supplies and Power Management

### 2.1 WLAN Power Management

The CYW43362 has been designed with the stringent power consumption requirements of portable devices in mind. All areas of the chip design are optimized to minimize power consumption. Silicon processes and cell libraries were chosen to reduce leakage current and supply voltages. Additionally, the CYW43362 integrated RAM is a low-leakage memory with dynamic clock control. The dominant supply current consumed by the RAM is leakage current only.

Additionally, the CYW43362 includes an advanced WLAN power management unit (PMU) sequencer. The PMU sequencer provides significant power savings by putting the CYW43362 into various power management states appropriate to the current environment and activities that are being performed. The power management unit enables and disables internal regulators, switches, and other blocks based on a computation of the required resources and a table that describes the relationship between resources and the time needed to enable and disable them. Power-up sequences are fully programmable. Configurable, free-running counters, which run on the 32.768 kHz low-power oscillator (LPO) sleep clock in the PMU sequencer, are used to turn individual regulators and power switches on and off. Clock speeds are dynamically changed, or gated off, as appropriate for the current mode. Slower clock speeds are used wherever possible.

The CYW43362 power states are described as follows:

- **Active mode**—All components in the CYW43362 are powered up and fully functional with active carrier sensing and frame transmission and receiving. All required regulators are enabled and put in the most efficient mode (PWM or Burst) based on the load current. Clock speeds are dynamically adjusted by the PMU sequencer.
- **Sleep mode**—The radio, AFE, PLLs, and the crystal oscillator are powered down. The rest of the CYW43362 remains powered up in an IDLE state. All main clocks are shut down. The 32.768-kHz LPO sleep clock is available only for the PMU sequencer. This condition is necessary to allow the PMU sequencer to wake up the chip and transition to Active mode. In Sleep mode, the primary power consumed is due to leakage current.
- **Power-down modes**—The CYW43362 has a full power-down mode and a low-power shutdown mode. A full power-down occurs when there is no VIO voltage, and WL\_RST\_N and EXT\_SMPS\_REQ are low. A low-power shutdown occurs when VIO is present, and WL\_RST\_N and EXT\_SMPS\_REQ are low. In low-power shutdown, only the band gap and LDO3P3 are on. Both power-down modes are exited when the host asserts either WL\_RST\_N or EXT\_SMPS\_REQ high.
- **External mode**—In this mode, the following are true:
  - The assertion of EXT\_SMPS\_REQ turns only the Core Buck (CBUCK) regulator on.
  - The WLAN is in reset (WL\_RST\_N = low).
  - The state of LDO3P3 and the band gap are dependent on VBAT and VIO.

### 2.2 Power Supply Topology

The CYW43362 contains a Power Management Unit (PMU), a buck-mode switching regulator, and three low noise LDOs. These integrated regulators simplify power supply design in WLAN embedded designs. All regulator inputs and outputs are brought out to pins on the CYW43362, providing system designers with the flexibility to choose which of the CYW43362 integrated regulators to use. One option is to supply the PMU from a single, variable power supply, VBAT, which can range from 2.3V to 4.8V. Using this option, all of the required voltages are provided by CYW43362 regulators except for a low current rail, VIO, which must be provided by the host to power the I/O signal buffers when the chip is out of reset.

Alternately, if specific rails such as 3.3V, 1.8V, and 1.2V already exist in the system, appropriate regulators in the CYW43362 can be bypassed, thereby reducing the cost and board space associated with external regulator components such as inductors and large capacitors.

The CBUCK and CLDO get powered whenever the reset signal is deasserted. The CBUCK regulator can be turned ON by asserting EXT\_SMPS\_REQ high. Asserting EXT\_PWM\_REQ high will set CBUCK to PWM mode. Driving EXT\_PWM\_REQ low will put CBUCK in Burst mode. Optionally, LNLDO may also be powered. All regulators are powered down only when the reset signal is asserted.

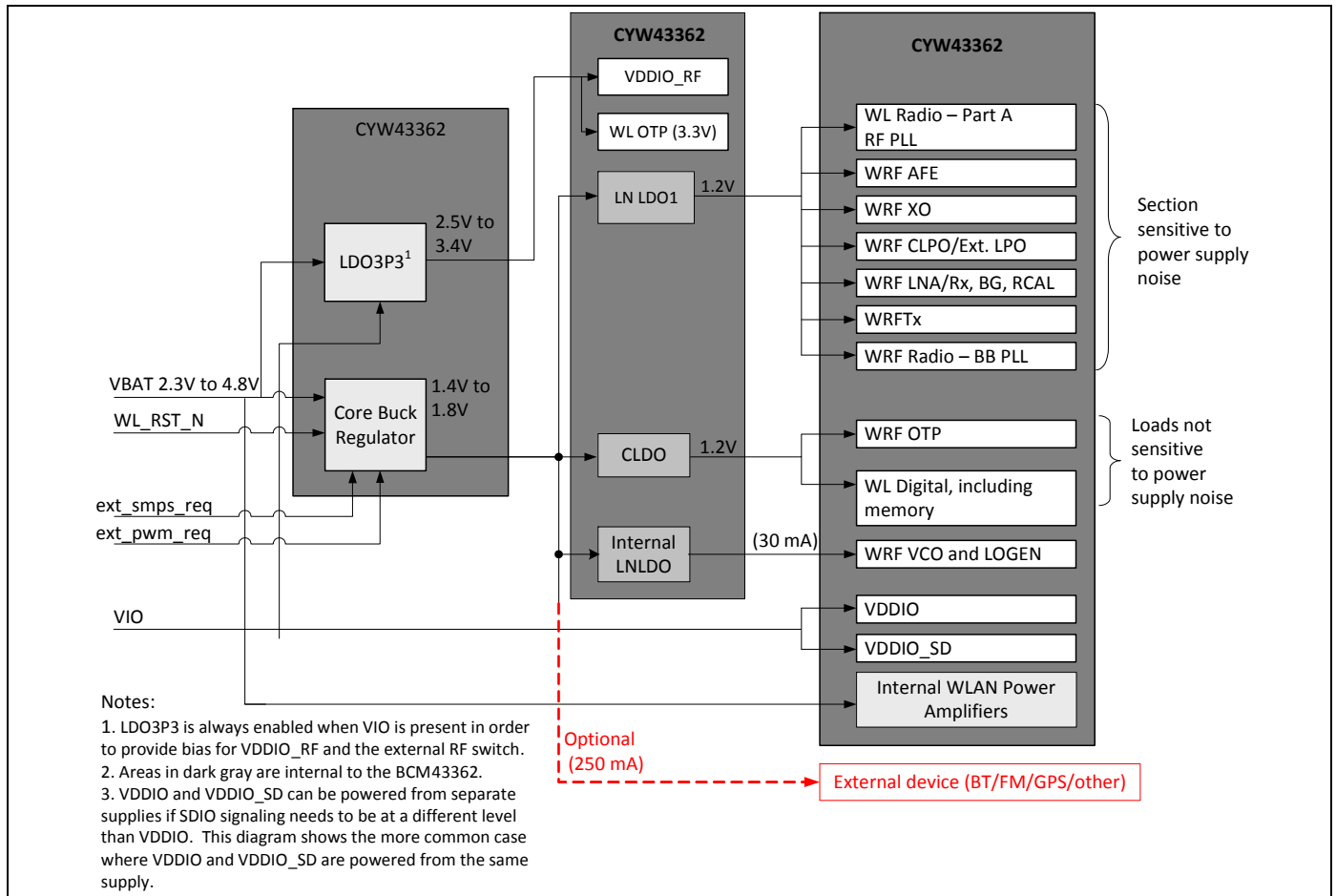
**Figure 3. Power Topology**

### 2.3 Voltage Regulators

All CYW43362 regulator output voltages are PMU programmable and have the following nominal capabilities. The currents listed below indicate regulator capabilities. See [System Power Consumption on page 43](#) for the actual expected loads.

- Core Buck switching regulator (CBLUCK): 2.3–4.8V input, nominal 1.5V output (up to 500 mA).
- LDO3P3: 2.3–4.8V input, nominal 3.3V output (up to 40 mA)
- CLDO (for the core): 1.45–2.0V input, nominal 1.2V output (up to 150 mA)
- Low-noise LNLDO1: 1.45–2.0V input, nominal 1.2V output (up to 150 mA)

See [Internal Regulator Electrical Specifications on page 39](#) for full regulator specifications.

### 2.4 PMU Sequencing

The WLAN PMU sequencer is responsible for minimizing system power consumption. It enables and disables various system resources based on a computation of the required resources and a table that describes the relationship between resources and the time needed to enable and disable them. Resource requests come from several sources: clock requests from cores, the minimum resources defined in the ResourceMin register, and the resources requested by any active resource request timers. The PMU sequencer maps clock requests into a set of resources required to produce the requested clocks.

Each resource is in one of four states: enabled, disabled, transition\_on, and transition\_off. Each resource has a timer that contains 0 when the resource is enabled or disabled and a nonzero value in the transition states. The timer is loaded with the resource's time\_on or time\_off value when the PMU determines that the resource must be enabled or disabled. That timer decrements on each LPO sleep clock. When it reaches 0, the state changes from transition\_off to disabled or transition\_on to enabled. If the time\_on value is 0, the resource can go immediately from disabled to enabled. Similarly, a time\_off value of 0 indicates that the resource can

go immediately from enabled to disabled. The terms enable sequence and disable sequence refer to either the immediate transition or the timer load-decrement sequence.

During each clock cycle, the PMU sequencer performs the following actions:

1. Computes the required resource set based on requests and the resource dependency table.
2. Decrements all timers whose values are nonzero. If a timer reaches 0, the PMU clears the ResourcePending bit for the resource and inverts the ResourceState bit.
3. Compares the request with the current resource status and determines which resources must be enabled or disabled.
4. Initiates a disable sequence for each resource that is enabled, no longer being requested, and has no powered-up dependents.
5. Initiates an enable sequence for each resource that is disabled, is being requested, and has all of its dependencies enabled.

## 2.5 Low-Power Shutdown

The CYW43362 provides a low-power shutdown feature that allows the device to be turned off while the host, and any other device in the system, remain operational. When WLAN is not needed, the WLAN core can be put in reset by asserting WL\_RST\_N (logic LOW). VDDIO\_RF and VDDIO remain powered while VIO and VBAT are both present, allowing the CYW43362 to be effectively off while keeping the I/O pins powered. During a low-power shut-down state, provided VIO continues to be supplied to the CYW43362, most outputs are tristated and most inputs are disabled. Input voltages must remain within the limits defined for normal operation. This is done to prevent current paths or create loading on any digital signals in the system, enabling the CYW43362 to be a fully integrated embedded device that takes full advantage of the lowest power-saving modes.

Two signals on the CYW43362, the system clock input (OSCIN) and sleep clock input (EXT\_SLEEP\_CLK), are designed to be high-impedance inputs that do not load down the driving signal even if the CYW43362 does not have VDDIO power applied to it. When the CYW43362 is powered on from this state, it is the same as a normal power-up, and the device does not contain any information about its state from before it was powered down.

## 2.6 CBUCK Regulator Features

The CBUCK regulator has several features that help make the CYW43362 ideal for mobile devices. First, the regulator uses 3.2 MHz as its PWM switching frequency for Buck regulation. This high frequency allows the use of small passive components for the switcher's external circuit, thereby saving PCB space in the design. In addition, the CBUCK regulator has three modes of operation: PWM mode for low-ripple output and for fast transient response and extended load ranges, Burst Mode for lower currents, and Low Power Burst Mode for higher efficiency when the load current is very low (Low Power Burst mode is not available for external devices).

The CBUCK supports external SMPS request to allow flexibility of supplying 1.8V to CYW43362, BCM2076, and other external devices when EXT\_SMPS\_REQ is asserted high. It also supports low ripple PWM mode (7 mVpp typical) for noise-sensitive applications when EXT\_PWM\_REQ is asserted high. A 100  $\mu$ s wait/settling time from the assertion of EXT\_PWM\_REQ high before increasing the load current allows the internal integrator precharging to complete. This is not a requirement, but is preferred.

Table 2 lists the mode the CBUCK operates in (Burst or PWM), based on various external control signals and internal CBUCK mode register settings.

**Table 2. CBUCK Operating Mode Selection**

WL_RST_L	EXT_SMPS_REQ	EXT_PWM_REQ	Internal CBUCK Mode Required	CBUCK Mode
0	0	X	X	Off
0	1	0	X	BURST
0	1	1	X	PWM
1	0	X	BURST	BURST
1	0	X	PWM	PWM
1	1	0	BURST	BURST
1	1	0	PWM	PWM
1	1	1	X	PWM

For detailed CBUCK performance specifications, see [Core Buck Regulator on page 39](#).

### 3. Frequency References

An external crystal is used for generating all radio frequencies and normal operation clocking. As an alternative, an external frequency reference driven by a temperature-compensated crystal oscillator (TCXO) signal may be used. No software settings are required to differentiate between the two. In addition, a low-power oscillator (LPO) is provided for lower power mode timing.

#### 3.1 Crystal Interface and Clock Generation

The CYW43362 can use an external crystal to provide a frequency reference. The recommended configuration for the crystal oscillator, including all external components, is shown in [Figure 4](#). Consult the reference schematics for the latest configuration.

**Figure 4. Recommended Oscillator Configuration**

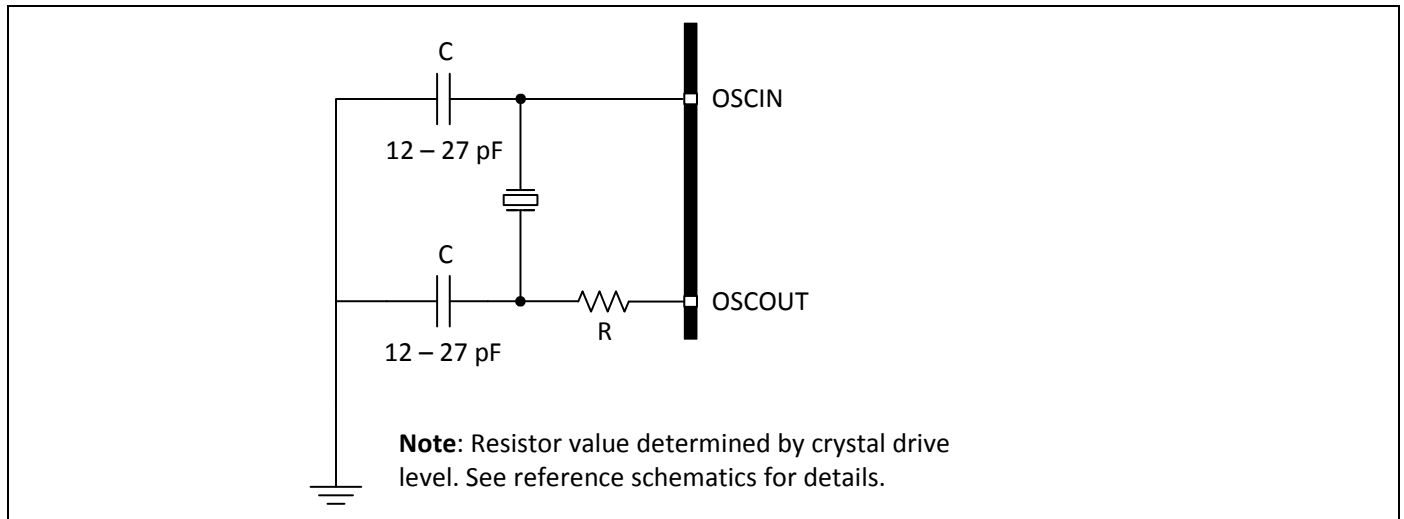

The CYW43362 uses a fractional-N synthesizer to generate the radio frequencies, clocks, and data/packet timing. This enables it to operate using numerous frequency references. This may either be an external source such as a TCXO or a crystal interfaced directly to the CYW43362.

The default frequency reference setting is a 26 MHz crystal or TCXO. The signal requirements and characteristics for the crystal interface are shown in [Table 3 on page 10](#).

**Note:** Although the fractional-N synthesizer can support many reference frequencies, frequencies other than the default require support to be added in the driver, plus additional extensive system testing. Contact Cypress for further details.

#### 3.2 TCXO

As an alternative to a crystal, an external precision TCXO can be used as the frequency reference, provided that it meets the Phase Noise requirements listed in [Table 3 on page 10](#). When the clock is provided by an external TCXO, there are two possible connection methods, as shown in [Figure 5](#) and [Figure 6](#):

1. If the TCXO is dedicated to driving the CYW43362, it should be connected to the OSC\_IN pin through an external 1000 pF coupling capacitor, as shown in [Figure 5](#). The internal clock buffer connected to this pin will be turned OFF when the CYW43362 goes into sleep mode. When the clock buffer turns ON and OFF, there will be a small impedance variation up to  $\pm 15\%$ . Power must be supplied to the WRF\_XTAL\_VDD1P2 pin.
2. An alternative is to DC-couple the TCXO to the WRF\_TCXO\_IN pin, as shown in [Figure 6](#). Use this method when the same TCXO is shared with other devices and a change in the input impedance is not acceptable because it may cause a frequency shift that cannot be tolerated by the other device sharing the TCXO. This pin is connected to a clock buffer powered from WRF\_TCXO\_VDD3P3. If the power supply to this buffer is always on (even in sleep mode), the clock buffer is always on, thereby ensuring a constant input impedance in all states of the device. The maximum current drawn from WRF\_TCXO\_VDD3P3 is approximately 500  $\mu\text{A}$ .

Figure 5. Recommended Circuit to Use with an External Dedicated TCXO

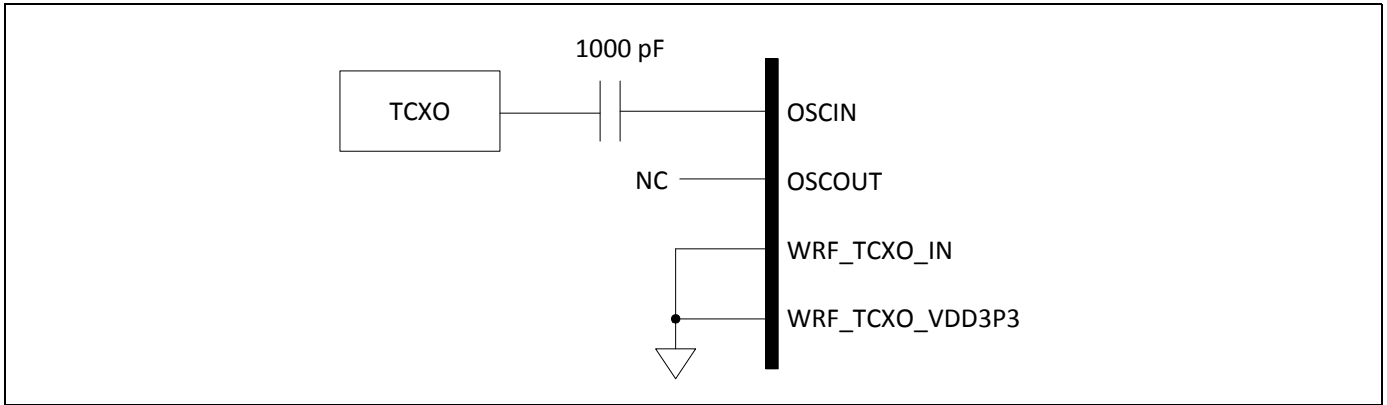

Figure 6. Recommended Circuit to Use with an External Shared TCXO

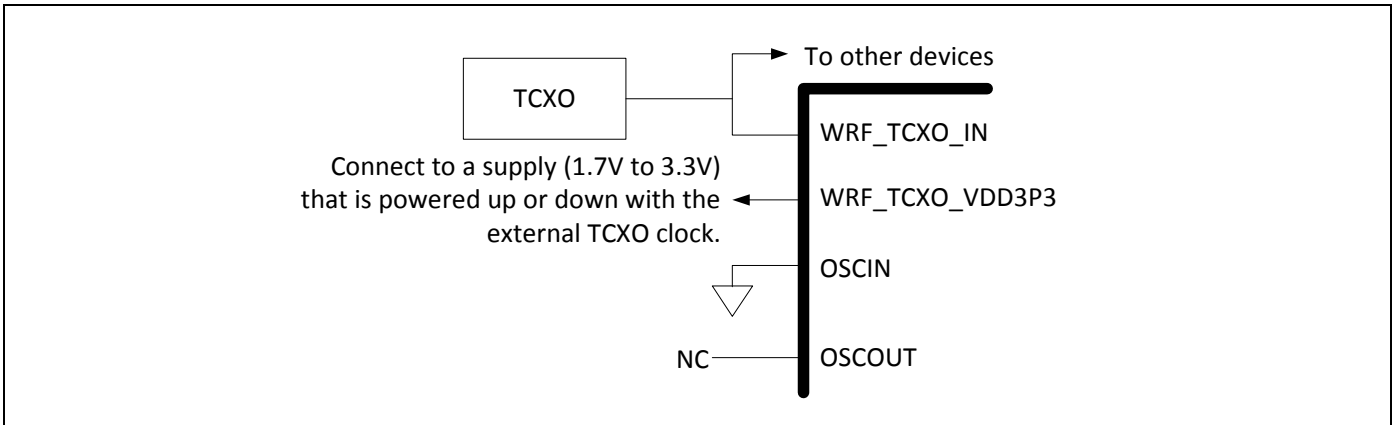

Table 3. Crystal Oscillator and External Clock Requirements and Performance

Parameter	Conditions/Notes	Crystal			External Frequency Reference			Units
		Min	Typ	Max	Min	Typ	Max	
Frequency	–	Between 12 MHz and 52 MHz <sup>a</sup>						
Crystal load capacitance	–	–	12	–				pF
ESR	–	–	–	60				Ω
Input Impedance (OSCIN) <sup>b</sup>	Resistive				30k	100k	–	Ω
	Capacitive				–	–	7.5	pF
Input Impedance (WRF_TCXO_IN)	Resistive				30k	100k	–	Ω
	Capacitive				–	–	4	pF
OSCIN input voltage	AC-coupled analog signal				400	–	1200	mV <sub>p-p</sub>
OSCIN input low level	DC-coupled digital signal				0	–	0.2	V
OSCIN input high level	DC-coupled digital signal				1.0	–	1.36	V
WRF_TCXO_IN input voltage	DC-coupled analog signal <sup>c</sup>				400	–	TCXO_VDD <sup>d</sup>	mV <sub>p-p</sub>
Frequency tolerance Initial + over temperature	–	–20	–	20	–20	–	20	ppm

**Table 3. Crystal Oscillator and External Clock Requirements and Performance (Cont.)**

Parameter	Conditions/Notes	Crystal			External Frequency Reference			Units
		Min	Typ	Max	Min	Typ	Max	
Duty cycle	26 MHz clock				40	50	60	%
Phase Noise <sup>e, f</sup> (IEEE 802.11 b/g)	26 MHz clock at 1 kHz offset				–	–	–119	dBc/Hz
	26 MHz clock at 10 kHz offset				–	–	–129	dBc/Hz
	26 MHz clock at 100 kHz offset				–	–	–134	dBc/Hz
	26 MHz clock at 1 MHz offset				–	–	–139	dBc/Hz
Phase Noise <sup>e, f</sup> (IEEE 802.11n, 2.4 GHz)	26 MHz clock at 1 kHz offset				–	–	–124	dBc/Hz
	26 MHz clock at 10 kHz offset				–	–	–134	dBc/Hz
	26 MHz clock at 100 kHz offset				–	–	–139	dBc/Hz
	26 MHz clock at 1 MHz offset				–	–	–144	dBc/Hz

- The frequency step size is approximately 80 Hz. The CYW43362 does not auto-detect the reference clock frequency; the frequency is specified in the software/NVRAM file.
- The internal clock buffer connected to this pin will be turned off when the CYW43362 goes into Sleep mode. When the clock buffer turns on and off, there will be a small impedance variation up to  $\pm 15\%$ .
- This input has an internal DC blocking capacitor, so do not include an external DC blocking capacitor.
- The maximum allowable voltage swing for the WRF\_TCXO\_IN input is equal to the WRF\_TCX0\_VDD3P3 supply voltage range, which is 1.7V to 3.3V.
- For a clock reference other than 26 MHz,  $20 \times \log_{10}(f/26)$  dB should be added to the limits, where  $f$  = the reference clock frequency in MHz.
- If the selected clock has a flat phase-noise response above 100 kHz, then it is acceptable to subtract 1 dB from all 1 kHz, 10 kHz, and 100 kHz values shown, and ignore the 1 MHz requirement.

### 3.3 External 32.768 kHz Low-Power Oscillator

The CYW43362 uses a secondary low-frequency sleep clock for low-power mode timing. Either the internal low-precision LPO or an external 32.768 kHz precision oscillator is required. The internal LPO frequency range is approximately  $33 \text{ kHz} \pm 30\%$  over process, voltage, and temperature, which is adequate for some applications. However, one trade-off caused by this wide LPO tolerance is a small current consumption increase during power save mode that is incurred by the need to wake up earlier to avoid missing beacons.

Whenever possible, the preferred approach is to use a precision external 32.768 kHz clock that meets the requirements listed in [Table 4](#).

**Note:** The CYW43362 will auto-detect the LPO clock. If it senses a clock on the EXT\_SLEEP\_CLK pin, it will use that clock. If it doesn't sense a clock, it will use its own internal LPO.

- To use the internal LPO: Tie EXT\_SLEEP\_CLK to ground. Do not leave this pin floating. To use an external LPO: Connect the external 32.768 kHz clock to EXT\_SLEEP\_CLK.

**Table 4. External 32.768 kHz Low-Power Oscillator Specifications**

Symbol	Parameter	Condition/Notes	Specification			Units
			Minimum	Typical	Maximum	
Fr	Frequency	–	–	32768	–	Hz
Δf/fr	Frequency tolerance	At 25°C	–30	–	+30	ppm
		–20°C <Ta< +70°C	–150	–	+40	
		–30°C <Ta< +85°C	–220	–	+40	
Duty cycle	–	–	30	–	70	%
Vol	Output low voltage	–	0	–	0.2	V
Voh	Output high voltage	–	0.7 Vio	–	Vio	V
Tr/Tf	Rise and fall time	–	–	–	100	ns
–	Signal type	Digital	–	–	–	–
–	Clock jitter	Integrated over 300 Hz to 15 kHz	–	–	30	ns
–	Input impedance	Resistive	10	–	–	MΩ
		Capacitive	–	–	2	pF
–	Input amplitude	Fail safe, 3.3V digital I/O	–	–	3.63	V

## 4. WLAN System Interfaces

### 4.1 SDIO v2.0

The CYW43362 WLAN section supports SDIO version 2.0. for both 1-bit (25 Mbps), 4-bit modes (100 Mbps), and high speed 4-bit (50 MHz clocks—200 Mbps). It has the ability to map the interrupt signal on a GPIO pin. This out-of-band interrupt signal notifies the host when the WLAN device wants to turn on the SDIO interface. The ability to force control of the gated clocks from within the WLAN chip is also provided.

SDIO mode is enabled using the strapping option pins. See [Table 9 on page 31](#) for details.

Three functions are supported:

- Function 0 Standard SDIO function (Max BlockSize/ByteCount = 32B)
- Function 1 Backplane Function to access the internal System On Chip (SOC) address space (Max BlockSize/ByteCount = 64B)
- Function 2 WLAN Function for efficient WLAN packet transfer through DMA (Max BlockSize/ByteCount = 512B)

#### 4.1.1 SDIO Pin Descriptions

**Table 5. SDIO Pin Descriptions**

SD 4-Bit Mode		SD 1-Bit Mode	
DATA0	Data line 0	DATA	Data line
DATA1	Data line 1 or Interrupt	IRQ	Interrupt
DATA2	Data line 2	NC	Not used
DATA3	Data line 3	NC	Not used
CLK	Clock	CLK	Clock
CMD	Command line	CMD	Command line

Figure 7. Signal Connections to SDIO Host (SD 4-Bit Mode)

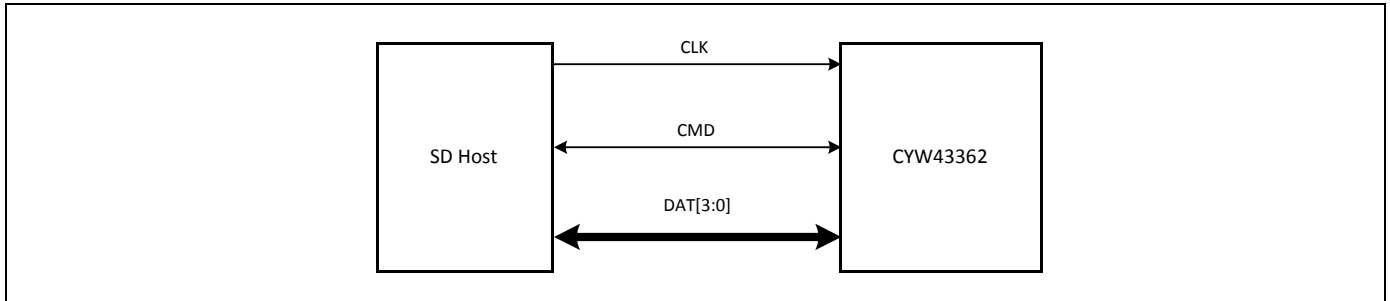
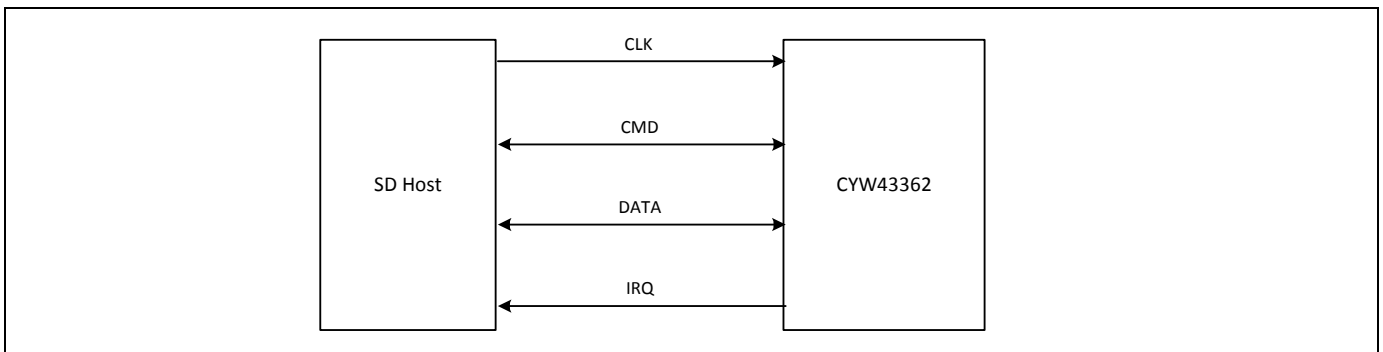

Figure 8. Signal Connections to SDIO Host (SD 1-Bit Mode)



#### 4.2 External Coexistence Interface

To manage wireless medium sharing for optimal performance, an external coexistence interface is provided that enables signaling between the CYW43362 and one or two external collocated wireless devices such as Bluetooth and/or WiMax. Note that three of the External Coexistence Interface pins are multiplexed with GPIOs. By default, the pins are BT\_COEX pins. Through software they can be changed to GPIOs. The fourth BT\_COEX signal is also multiplexed with a GPIO, but this one is a GPIO by default and can be changed via software to be BTCX\_FREQ. See [Pinout and Signal Descriptions on page 23](#) for more details.

The signals in [Table 6](#) can be enabled by software.

Table 6. Coexistence Signals

Signal	Description
BTCX_STATUS	Coexistence signal indicating Bluetooth priority status and TX/RX direction.
BTCX_RF_ACTIVE	Coexistence signal indicating that Bluetooth is active.
BTCX_FREQ	Indicates that the coexisting Bluetooth is about to transmit on a restricted channel.
BTCX_TXCONF	Coexistence output giving Bluetooth permission to transmit.

**Figure 9. 4-Wire Coexistence Wiring**

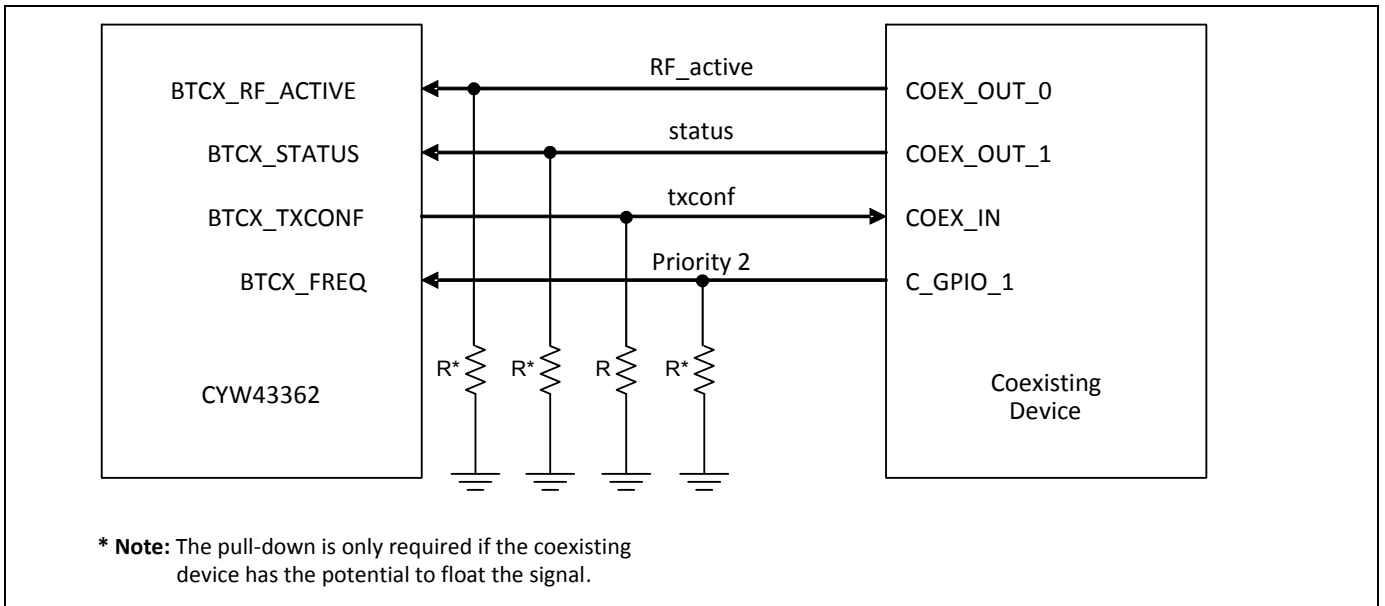

## 5. Wireless LAN MAC and PHY

### 5.1 MAC Features

The CYW43362 WLAN MAC supports features specified in the IEEE 802.11 base standard, and amended by IEEE 802.11n. The salient features are listed below:

- Transmission and reception of aggregated MPDUs (A-MPDU)
- Support for power management schemes, including WMM power-save, power-save multipoll (PSMP) and multiphase PSMP operation.
- Support for immediate ACK and Block-ACK policies
- Interframe space timing support, including RIFS
- Support for RTS/CTS and CTS-to-self frame sequences for protecting frame exchanges
- Back-off counters in hardware for supporting multiple priorities as specified in the WMM specification
- Timing synchronization function (TSF), network allocation vector (NAV) maintenance, and target beacon transmission time (TBTT) generation in hardware
- Hardware off-load for AES-CCMP, legacy WPA TKIP, legacy WEP ciphers, WAPI, and support for key management
- Support for coexistence with Bluetooth and other external radios
- Programmable independent basic service set (IBSS) or infrastructure basic service set functionality
- Statistics counters for MIB support

#### 5.1.1 MAC Description

The CYW43362 WLAN MAC is designed to support high throughput operation with low-power consumption. It does so without compromising on Bluetooth coexistence policies, thereby enabling optimal performance over both networks. In addition, several power-saving modes that have been implemented allow the MAC to consume very little power while maintaining network-wide timing synchronization. The architecture diagram of the MAC is shown in [Figure 10 on page 15](#).

**Figure 10. WLAN MAC Architecture**

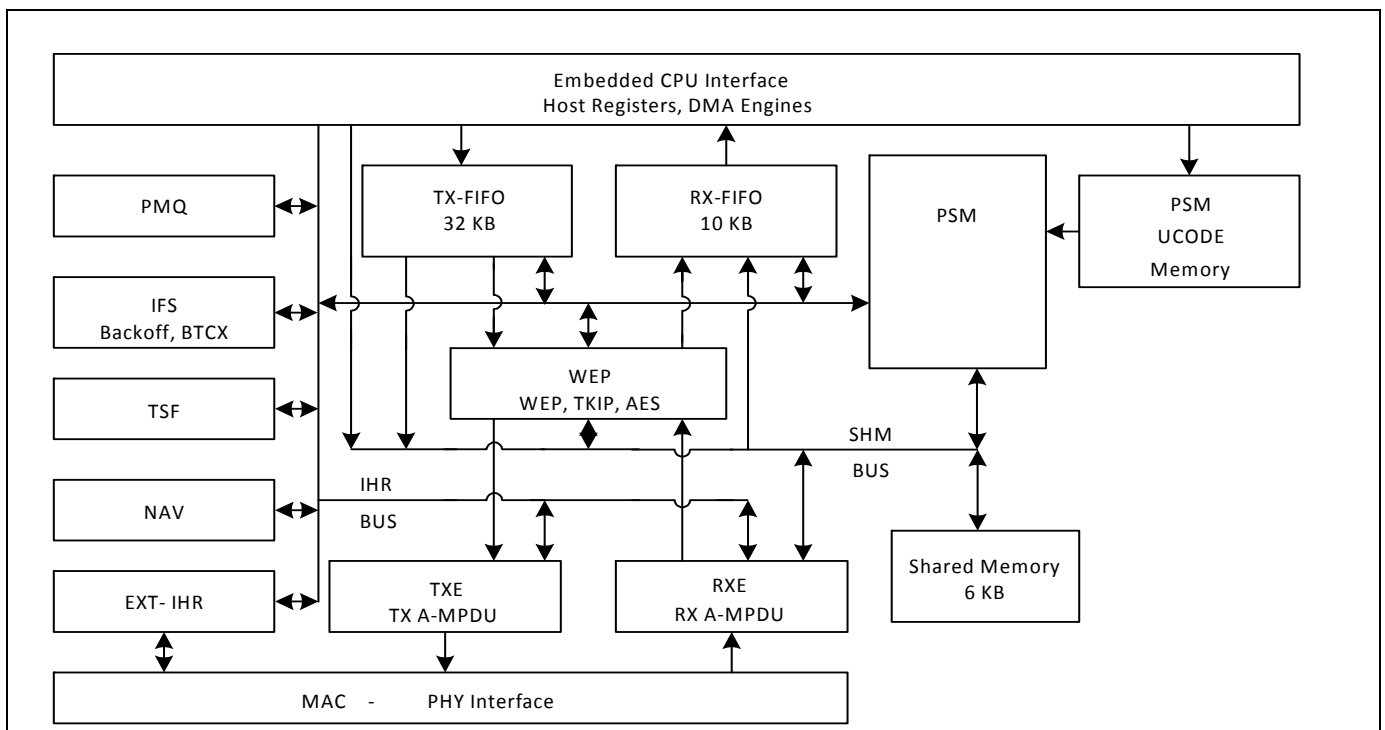

The following sections provide an overview of the important modules in the MAC.

#### **5.1.1.1 PSM**

The programmable state machine (PSM) is a microcoded engine that provides most of the low-level control to the hardware to implement the IEEE 802.11 specification. It is a microcontroller that is highly optimized for flow control operations, which are predominant in implementations of communication protocols. The instruction set and fundamental operations are simple and general, which allows algorithms to be optimized until very late in the design process. It also allows for changes to the algorithms to track evolving IEEE 802.11 specifications.

The PSM fetches instructions from the microcode memory. It uses the shared memory to obtain operands for instructions, as a data store, and to exchange data between both the host and the MAC data pipeline (via the SHM bus). The PSM also uses a scratchpad memory (similar to a register bank) to store frequently accessed and temporary variables.

The PSM exercises fine-grained control over the hardware engines by programming internal hardware registers (IHR). These IHRs are collocated with the hardware functions they control and are accessed by the PSM via the IHR bus.

The PSM fetches instructions from the microcode memory using an address determined by the program counter, instruction literal, or a program stack. For ALU operations, the operands are obtained from shared memory, scratchpad, IHRs, or instruction literals, and the results are written into the shared memory, scratchpad, or IHRs.

There are two basic branch instructions: conditional branches and ALU based branches. To better support the many decision points in the IEEE 802.11 algorithms, branches can depend on either a readily available signals from the hardware modules (branch condition signals are available to the PSM without polling the IHRs), or on the results of ALU operations.

#### **5.1.1.2 WEP**

The wired equivalent privacy (WEP) engine encapsulates all the hardware accelerators to perform the encryption and decryption, as well as MIC computation and verification. The accelerators implement the following cipher algorithms: legacy WEP, WPA TKIP, WPA2 AES-CCMP.

Based on the frame type and association information, the PSM determines the appropriate cipher algorithm to be used. It supplies the keys to the hardware engines from an on-chip key table. The WEP interfaces with the TXE to encrypt and compute the MIC on transmit frames, and the RXE to decrypt and verify the MIC on receive frames. WAPI is also supported.

#### **5.1.1.3 TXE**

The transmit engine (TXE) constitutes the transmit data path of the MAC. It coordinates the DMA engines to store the transmit frames in the TXFIFO. It interfaces with WEP module to encrypt frames and transfers the frames across the MAC-PHY interface at the appropriate time determined by the channel access mechanisms.

The data received from the DMA engines are stored in transmit FIFOs. The MAC supports multiple logical queues to support traffic streams that have different QoS priority requirements. The PSM uses the channel access information from the IFS module to schedule a queue from which the next frame is transmitted. Once the frame is scheduled, the TXE hardware transmits the frame based on a precise timing trigger received from the IFS module.

The TXE module also contains the hardware that allows the rapid assembly of MPDUs into an A-MPDU for transmission. The hardware module aggregates the encrypted MPDUs by adding appropriate headers and pad delimiters as needed.

#### **5.1.1.4 RXE**

The receive engine (RXE) constitutes the receive data path of the MAC. It interfaces with the DMA engine to drain the received frames from the RXFIFO. It transfers bytes across the MAC-PHY interface and interfaces with the WEP module to decrypt frames. The decrypted data is stored in the RXFIFO.

The RXE module contains programmable filters that are programmed by the PSM to accept or filter frames based on several criteria such as receiver address, BSSID, and certain frame types.

The RXE module also contains the hardware required to detect A-MPDUs, parse the headers of the containers, and disaggregate them into component MPDUS.

#### **5.1.1.5 IFS**

The IFS module contains the timers required to determine interframe space timing including RIFS timing. It also contains multiple back-off engines required to support prioritized access to the medium as specified by WMM.

The interframe spacing timers are triggered by the cessation of channel activity on the medium, as indicated by the PHY. These timers provide precise timing to the TXE to begin frame transmission. The TXE uses this information to send response frames or perform transmit frame-bursting (RIFS or SIFS separated, as within a TXOP).

The back-off engines (for each access category) monitor channel activity, in each slot duration, to determine whether to continue or pause the back-off counters. When the back-off counters reach 0, the TXE gets notified, so that it may commence frame transmission. In the event of multiple back-off counters decrementing to 0 at the same time, the hardware resolves the conflict based on policies provided by the PSM.

The IFS module also incorporates hardware that allows the MAC to enter a low-power state when operating under the IEEE power-saving mode. In this mode, the MAC is in a suspended state with its clock turned off. A sleep timer, whose count value is initialized by the PSM, runs on a slow clock and determines the duration over which the MAC remains in this suspended state. Once the timer expires, the MAC is restored to its functional state. The PSM updates the TSF timer based on the sleep duration, ensuring that the TSF is synchronized to the network.

The IFS module also contains the PTA hardware that assists the PSM in Bluetooth coexistence functions.

#### **5.1.1.6 TSF**

The timing synchronization function (TSF) module maintains the TSF timer of the MAC. It also maintains the target beacon transmission time (TBTT). The TSF timer hardware, under the control of the PSM, is capable of adopting timestamps received from beacon and probe response frames in order to maintain synchronization with the network.

The TSF module also generates trigger signals for events that are specified as offsets from the TSF timer, such as uplink and downlink transmission times used in PSMP.

#### **5.1.1.7 NAV**

The network allocation vector (NAV) timer module is responsible for maintaining the NAV information conveyed through the duration field of MAC frames. This ensures that the MAC complies with the protection mechanisms specified in the standard.

The hardware, under the control of the PSM, maintains the NAV timer and updates the timer appropriately based on received frames. This timing information is provided to the IFS module, which uses it as a virtual carrier-sense indication.

#### **5.1.1.8 MAC-PHY Interface**

The MAC-PHY interface consists of a data path interface to exchange RX/TX data from/to the PHY. In addition, there is a programming interface, which can be controlled either by the host or the PSM to configure and control the PHY.

### **5.2 PHY Description**

The CYW43362 WLAN Digital PHY is designed to comply with IEEE 802.11b/g/n single stream to provide wireless LAN connectivity supporting data rates from 1 Mbps to 72 Mbps for low-power, high-performance handheld applications.

The PHY has been designed to meet specification requirements in the presence of interference, radio nonlinearity, and impairments. It incorporates efficient implementations of the Filters, FFT and Viterbi decoder algorithms. Efficient algorithms have been designed to achieve maximum throughput and reliability, including algorithms for carrier sense/rejection, frequency/phase/timing acquisition and tracking, channel estimation and tracking. The PHY receiver also contains a robust 11b demodulator. The PHY carrier sense has been tuned to provide high throughput for IEEE 802.11g/11b hybrid networks with Bluetooth coexistence.

5.2.1 PHY Features

- Supports IEEE 802.11b, 11g, 11n single-stream standards.
- Supports Optional Greenfield mode in Tx and Rx.
- Supports optional STBC receive of two space-time stream.
- Supports IEEE 802.11h/d for worldwide operation.
- Algorithms achieving low power, enhanced sensitivity, range, and reliability
- Algorithms to maximize throughput performance in presence of Bluetooth
- Automatic gain control scheme for blocking and non blocking application scenario for cellular applications.
- Closed loop transmit power control
- Supports per packet Rx Antenna diversity.
- Designed to meet FCC and other regulatory requirements.

Figure 11. WLAN PHY Block Diagram

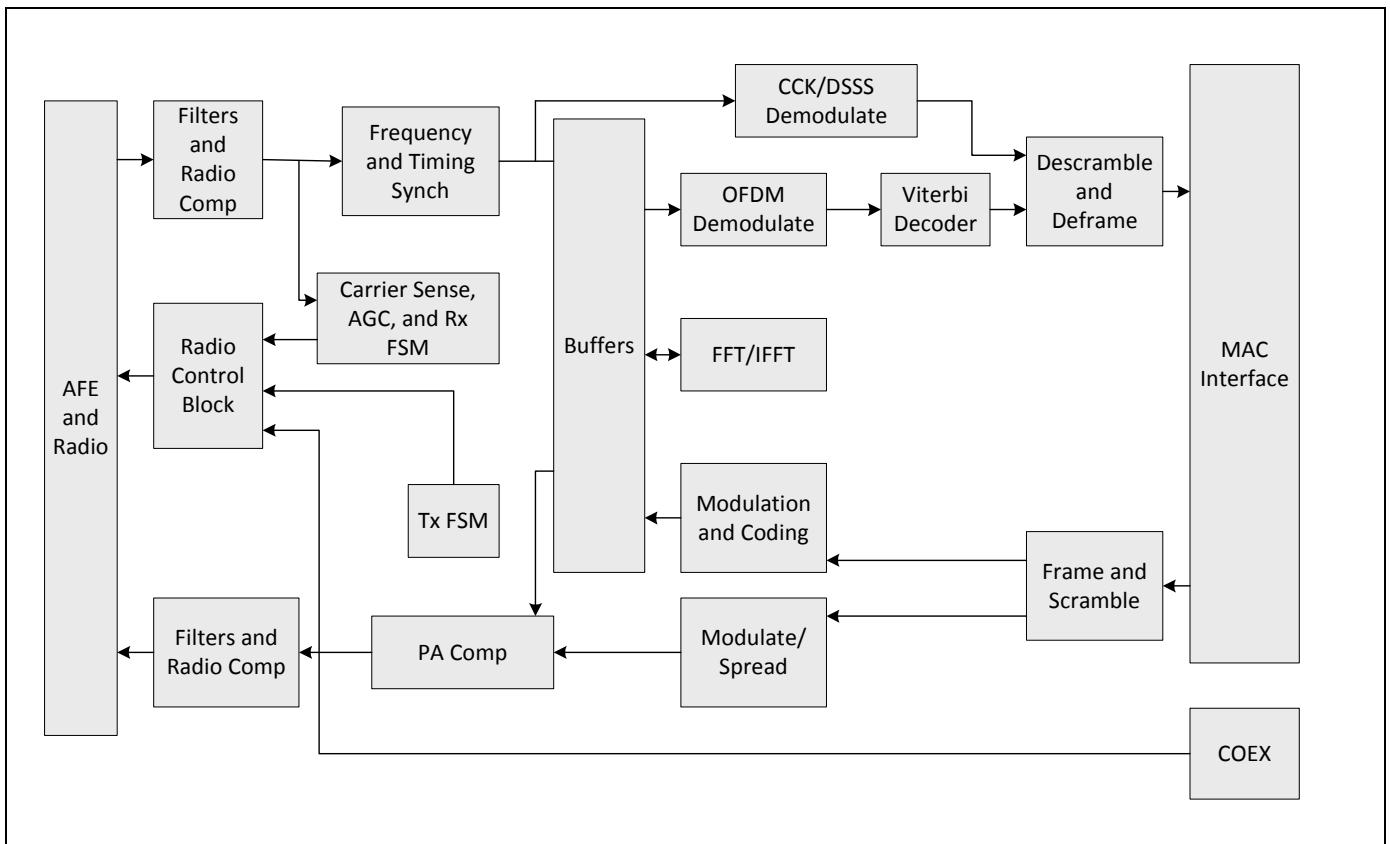

The PHY is capable of fully calibrating the RF front-end to extract the highest performance. On power-up, the PHY performs a full calibration suite to correct for IQ mismatch and local oscillator leakage. The PHY also performs periodic calibration to compensate for any temperature related drift, thus maintaining high-performance over time. A closed loop transmit control algorithm maintains the output power to required level with capability control Tx power on a per packet basis.

One of the key feature of the PHY is two space-time stream receive capability. The STBC scheme can obtain diversity gains by using multiple transmit antennas in AP (Access Point) in a fading channel environment, without increasing the complexity at the STA. Details of the STBC receive are shown in the block diagram in [Figure 12 on page 19](#).

Figure 12. STBC Receive Block Diagram

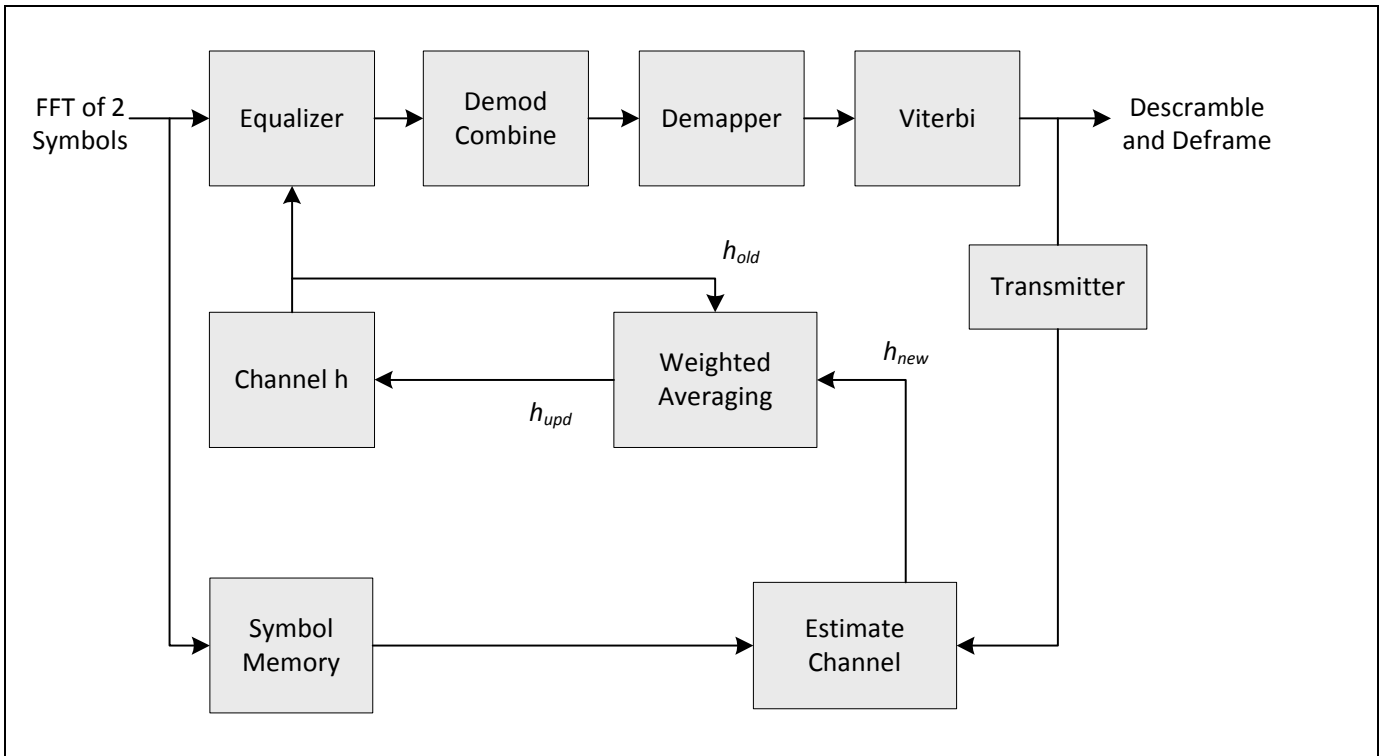

In STBC mode, symbols are processed in pairs. Equalized output symbols are linearly combined and decoded. Channel estimation is refined on every pair of symbols using the received symbols and reconstructed symbols.

## 6. WLAN Radio Subsystem

The CYW43362 includes an integrated WLAN RF transceiver that has been optimized for use in 2.4 GHz Wireless LAN systems. It is designed to provide low power, low cost, and robust communications for applications operating in the globally available 2.4 GHz unlicensed ISM band. The transmit and receive sections include all on-chip filtering, mixing, and gain control functions. Improvements to the radio design include shared Tx/Rx baseband filters and high immunity to supply noise.

Figure 13. Radio Functional Block Diagram

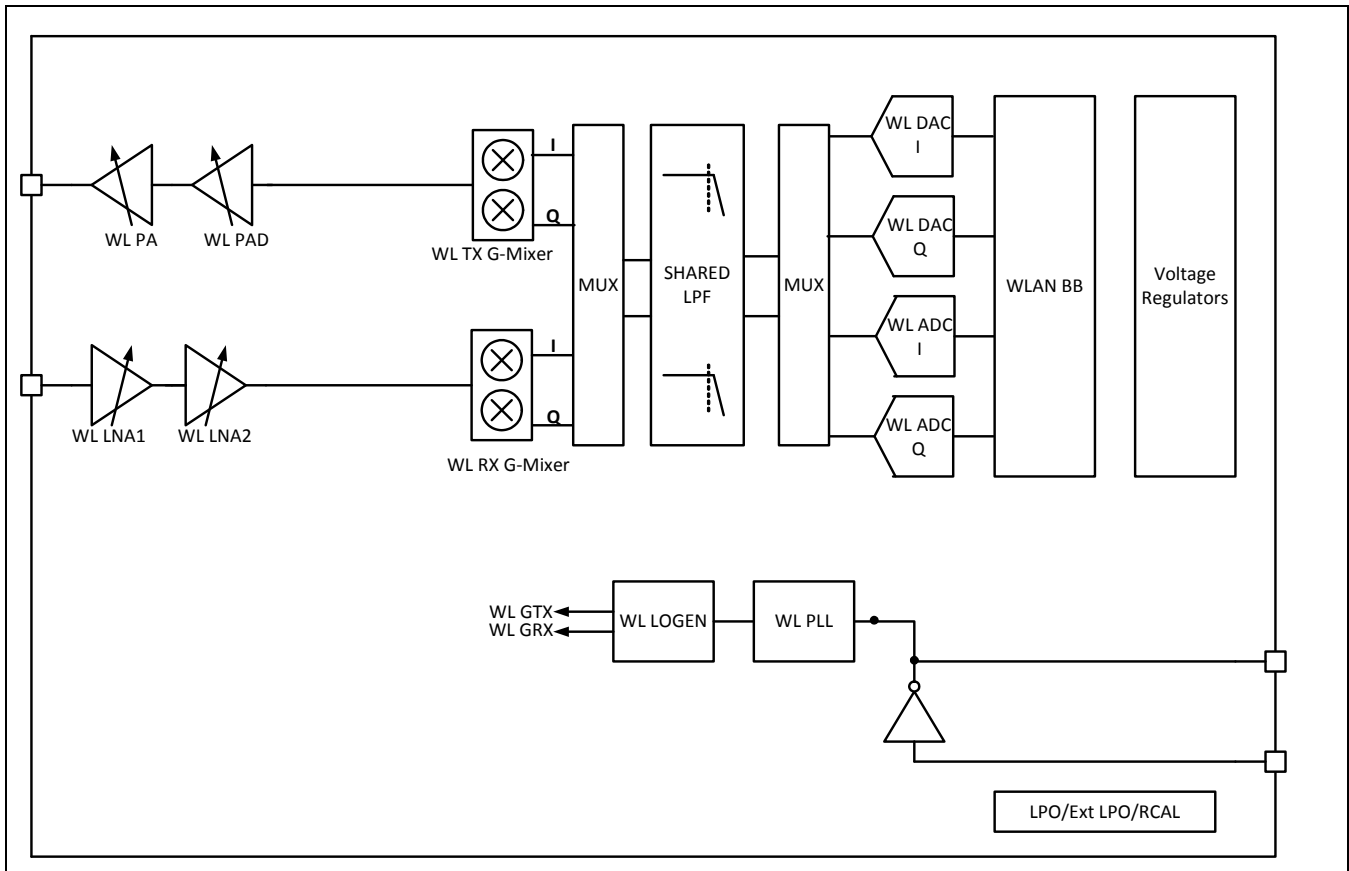

### 6.1 Receive Path

The CYW43362 has a wide dynamic range, direct conversion receiver. It employs high order on-chip channel filtering to ensure reliable operation in the noisy 2.4 GHz ISM band.

### 6.2 Transmit Path

Baseband data is modulated and upconverted to the 2.4 GHz ISM band. A linear on-chip power amplifier is included, which is capable of delivering high output powers while meeting IEEE 802.11b/g/n specifications without the need for an external PA. This PA can be powered directly from VBAT, thereby eliminating the need for a separate PALDO. Closed-loop output power control is completely integrated.

### 6.3 Calibration

The CYW43362 features dynamic on-chip calibration, eliminating process variation across components. This enables the CYW43362 to be used in high-volume applications, because calibration routines are not required during manufacturing testing. These calibration routines are performed periodically in the course of normal radio operation. Examples of this automatic calibration are baseband filter calibration for optimum transmit and receive performance and LOFT calibration for leakage reduction. In addition, I/Q Calibration, R Calibration, and VCO Calibration are performed on-chip.

## 7. CPU and Global Functions

### 7.1 WLAN CPU and Memory Subsystem

The CYW43362 includes an integrated ARM Cortex™-M3 processor with internal RAM and ROM. The ARM Cortex-M3 processor is a low-power processor that features low gate count, low interrupt latency, and low-cost debugging. It is intended for deeply embedded applications that require fast interrupt response features. The processor implements the ARM® architecture v7-M with support for Thumb®-2 instruction set. ARM Cortex-M3 delivers 30% more performance gain over ARM7TDMI.

At 0.19  $\mu\text{W}/\text{MHz}$ , the Cortex-M3 is the most power efficient general purpose microprocessor available, outperforming 8- and 16-bit devices on MIPS/ $\mu\text{W}$ . It supports integrated sleep modes.

ARM Cortex-M3 uses multiple technologies to reduce cost through improved memory utilization, reduced pin overhead, and reduced silicon area. ARM Cortex-M3 supports independent buses for Code and Data access (Icode/Dcode and System buses). ARM Cortex-M3 supports extensive debug features including real time trace of program execution.

On-chip memory for the CPU includes 240 KB SRAM and 448 KB ROM.

### 7.2 One-Time Programmable Memory

Various hardware configuration parameters may be stored in an internal 1024-bit One-Time Programmable (OTP) memory, which is read by system software after device reset. In addition, customer-specific parameters, including the system vendor ID and the MAC address, can be stored, depending on the specific board design.

The initial state of all bits in an unprogrammed OTP device is 0. After any bit is programmed to a 1, it cannot be reprogrammed to 0. The entire OTP array can be programmed in a single write cycle using a utility provided with the Cypress WLAN manufacturing test tools. Alternatively, multiple write cycles can be used to selectively program specific bytes, but only bits which are still in the 0 state can be altered during each programming cycle.

Prior to OTP programming, all values should be verified using the appropriate editable nvram.txt file, which is provided with the reference board design package. Documentation on the OTP development process is available on the Cypress customer support portal.

### 7.3 GPIO Interface

Five general purpose I/O (GPIO) pins are available on the CYW43362 that can be used to connect to various external devices.

GPIOs are tristated by default. Subsequently, they can be programmed to be either input or output pins via the GPIO control register. They can also be programmed to have internal pull-up or pull-down resistors.

GPIO\_0 is initially used as a strapping option to select between SDIO.

GPIOs 3, 4, and 5 are multiplexed with the Bluetooth Coexistence Interface. By default, these pins are BT\_COEX pins. Software can reprogram these pins to behave as GPIOs.

GPIO\_1 is a GPIO by default, but can be reprogrammed by software to become the BTCX\_FREQ signal.

### 7.4 JTAG Interface

The CYW43362 supports the IEEE 1149.1 JTAG boundary scan standard for performing device package and PCB assembly testing during manufacturing. In addition, the JTAG interface allows Cypress to assist customers by using proprietary debug and characterization test tools during board bring-up. Therefore, it is highly recommended to provide access to the JTAG pins by means of test points or a header on all PCB designs.

### 7.5 UART Interface

One UART interface can be enabled by software as an alternate function on the JTAG pins. UART\_RX is available on the JTAG\_TDI pin, and UART\_TX is available on the JTAG\_TDO pin.

The UART is primarily for debugging during development. By adding an external RS-232 transceiver, this UART enables the CYW43362 to operate as RS-232 data termination equipment (DTE) for exchanging and managing data with other serial devices. It is compatible with the industry standard 16550 UART, and it provides a FIFO size of  $64 \times 8$  in each direction.

## 8. WLAN Software Architecture

### 8.1 Host Software Architecture

The host driver (DHD) provides a transparent connection between the host operating system and the CYW43362 media (for example, WLAN) by presenting a network driver interface to the host operating system and communicating with the CYW43362 over an interface-specific bus (SDIO) to:

- Forward transmit and receive frames between the host network stack and the CYW43362 device, and
- Pass control requests from the host to the CYW43362 device, returning the CYW43362 device responses

The driver communicates with the CYW43362 over the bus using a control channel and a data channel to pass control messages and data messages. The actual message format is based on the BDC protocol.

### 8.2 Device Software Architecture

The wireless device, protocol, and bus drivers are run on the embedded ARM® processor using a Cypress-defined operating system called HND RTE, which transfers data over a propriety Cypress format over the SDIO interface between the host and device (BDC/LMAC). The data portion of the format consists of IEEE 802.11 frames wrapped in a Cypress encapsulation. The host side architecture provides all missing functionality between a network device and the Cypress device interface. The host can also be customized to provide functionality between the Cypress device interface and a full network device interface.

This transfer requires a message-oriented (framed) interconnect between the host and device. The SDIO bus is an addressed bus—each host-initiated bus operation contains an explicit device target address—and does not natively support a higher-level data frame concept. Cypress has implemented a hardware/software message encapsulation scheme that ignores the bus operation code address and prefixes each frame with a 4-byte length tag for framing. The device presents a packet-level interface over which data, control, and asynchronous event (from the device) packets are supported.

The data and control packets received from the bus are initially processed by the bus driver and then passed on to the protocol driver. If the packets are data packets, they are transferred to the wireless device driver (and out through its medium), and a data packet received from the device medium follows the same path in the reverse direction. If the packets are control packets, the protocol header is decoded by the protocol driver. If the packets are wireless IOCTL packets, the IOCTL API of the wireless driver is called to configure the wireless device. The microcode running in the D11 core processes all time-critical tasks.

#### 8.2.1 Remote Downloader

When the CYW43362 powers up, the DHD initializes and downloads the firmware to run in the device.

**Figure 14. WLAN Software Architecture**

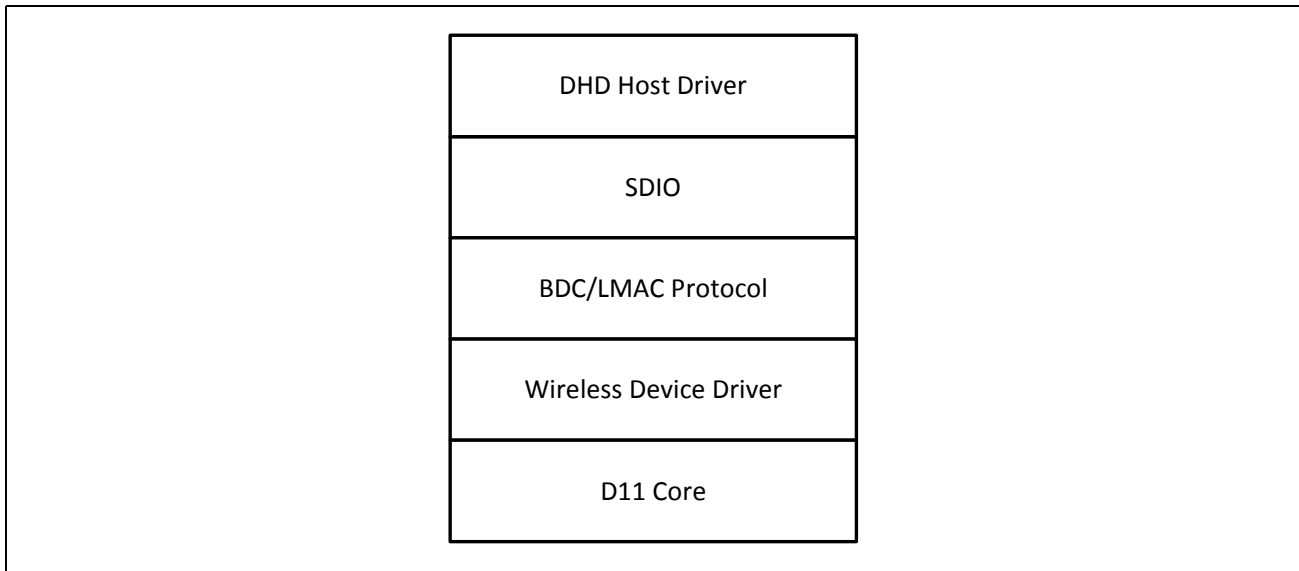



### 8.3 Wireless Configuration Utility

The device driver that supports the Cypress IEEE 802.11 family of wireless solutions provides an input/output control (IOCTL) interface for settings. The IOCTL interface makes it possible to make settings that are normally not possible when using just the native operating system function mechanisms. The utility uses IOCTLs to query or set a number of different driver/chip operating properties.

## 9. Pinout and Signal Descriptions

### 9.1 Signal Assignments

Figure 15 shows the 69-Ball WLPGA ball map.

Table 7 on page 24 shows the WLPGA signal descriptions.

**Figure 15. 69-Ball WLPGA Ball Map**

	A	B	C	D	E	F	G	H	J
1	WRF_RF1N	WRF_RFOUT		WRF_PA_VDD	RF_SW_CTRL_0	RF_SW_CTRL_1	VDDIO_RF	VOUT_3P3	SR_VDDBAT
2		WRF_PA_GND		WRF_PA_GND	WRF_PADRV_GND	RF_SW_CTRL_3	RF_SW_CTRL_2	VDD	SR_VDDBAT
3	WRF_LNA_VDD1P2			WRF_PADRV_VDD	VSS	VSS	VSS	VDD	EXT_SWPS_RE
4	WRF_LNA_GND	WRF_ANA_VDD1P2	WRF_GPIO_OUT	WRF_ANA_GND	GPIO_0	VSS	VSS	VDDIO	WL_RST_N
5	WRF_VCO_LDO_IN_VDD1P8		WRF_VCO_LDO_OUT_VDD1P2	WRF_RES_EXT	GPIO_1 / BTCX_FREQ	SDIO_DATA_2	JTAG_TDO	BTCX_TXCONF/ GPIO_3	EXT_SLEEP_C
6	WRF_VCO_GND		WRF_XTAL_GND	OSCOUT	WRF_AFE_GND	XTAL_PU	JTAG_TMS	JTAG_TDI	BTCX_STATU GPIO_4
7	WRF_TCXO_IN	WRF_TCXO_VDD3P3	WRF_XTAL_VDD1P2	OSCIN		WRF_AFE_VDD1P2	JTAG_TRST_L	JTAG_TCK	BTCX_RF_ACTI GPIO_5
	A	B	C	D	E	F	G	H	J

**Table 7. WLBGA Signal Descriptions**

Ball #	Signal Name	Type	Description
<b>WLAN RF Interface</b>			
A1	WRF_RFIN	I	WLAN IEEE 802.11n RX input (50Ω)
B1	WRF_RFOUT	O	WLAN IEEE 802.11n internal power amplifier output (50Ω)
D5	WRF_RES_EXT	I	Connect to external 15 kΩ resistor (1%) to ground
<b>RF Control Lines (IO Supply = VDDIO_RF)</b>			
E1	RF_SW_CTRL0	O	RF switch control line. Default at this pin is high.
F1	RF_SW_CTRL1	O	RF switch control line. Default at this pin is low.
G2	RF_SW_CTRL2	O	RF switch control line. Default at this pin is low.
F2	RF_SW_CTRL3	O	RF switch control line. Default at this pin is low.
<b>Note:</b>			
1. Use only RF_SW_CTRL1 and RF_SW_CTRL2 unless diversity is required, in which case RF_SW_CTRL0 and RF_SW_CTRL3 can also be used to select the antenna for a pair of SPDT switches.			
2. For a transfer switch, use only RF_SW_CTRL1 and RF_SW_CTRL2 with the main antenna to Rx when RF_SW_CTRL1 is high.			
3. For a diamond-type switch, do the following:			
<ul style="list-style-type: none"> <li>■ RF_SW_CTRL0 must select WLAN Tx, aux antenna.</li> <li>■ RF_SW_CTRL1 must select WLAN Rx, main antenna.</li> <li>■ RF_SW_CTRL2 must select WLAN Tx, main antenna.</li> <li>■ RF_SW_CTRL2 must select WLAN Rx, aux antenna.</li> </ul>			
4. For cases where a shared antenna is used for WLAN and Bluetooth, RF_SW_CNTRL_0 defaults to HIGH when the CYW43362 is in reset. Use a switch topology in which the Bluetooth RF path is connected to the antenna when this signal is HIGH. This allows Bluetooth access to the antenna when WLAN is in reset.			
5. The following is a list of the internal pull-up/pull-down resistor strengths for the RF switch control lines when the CYW43362 is in reset:			
		Minimum	Typical
– pup @ 3.3V	39K	58K	69K
– pdn @ 3.3V	39K	58K	67K
6. The default drive strength is 6.0 mA.			

**Table 7. WLPGA Signal Descriptions (Cont.)**

Ball #	Signal Name	Type	Description
<b>SDIO Interface</b>			
F5	SDIO_DATA_2	I/O	SDIO data line 2. This pin has an internal weak pull-up resistor. <b>Note:</b> By default, the internal pull-up is enabled, but it can be disabled via software.
L6	SDIO_DATA_0	I/O	SDIO data line 0. This pin has an internal weak pull-up resistor. <b>Note:</b> By default, the internal pull-up is enabled, but it can be disabled via software.
L5	SDIO_DATA_1	I/O	SDIO data line 1. This pin has an internal weak pull-up resistor. <b>Note:</b> By default, the internal pull-up is enabled, but it can be disabled via software.
L7	SDIO_CLK	I	SDIO clock.
K6	SDIO_DATA_3	I/O	SDIO data line 3. This pin has an internal weak pull-up resistor. <b>Note:</b> By default, the internal pull-up is enabled, but it can be disabled by software.
K7	SDIO_CMD	I/O	SDIO command line. This pin has an internal weak pull-up resistor. <b>Note:</b> By default, the internal pull-up is enabled, but it can be disabled by software.
<b>SDIO weak internal pull-up resistances:</b> For 1.8V (minimum, typical, maximum): 34 kΩ, 51 kΩ, 86 kΩ For 2.5V (minimum, typical, maximum): 21 kΩ, 32 kΩ, 54 kΩ For 3.3V (minimum, typical, maximum): 16 kΩ, 24 kΩ, 37 kΩ  <b>Software programmable SDIO drive strength options:</b> For 1.8V: 0.5 mA, 1.0 mA, 1.5 mA, 2.0 mA, 2.5 mA (default), and 3.0 mA For 2.5V: 1.5 mA, 3.0 mA, 4.5 mA, 6.0 mA, 7.5 mA (default), and 9.0 mA For 3.3V: 2.0 mA, 4.0 mA, 6.0 mA, 8.0 mA, 10.0 mA (default), and 12.0 mA			
<b>JTAG Interface</b>			
G6	JTAG_TMS	I	For normal operation, connect as described in the JTAG specification (IEEE Std 1149.1). Otherwise, if JTAG is not used, this pin can be left unconnected (NC) as it has an internal weak pull-up resistor.
G5	JTAG_TDO	O	For normal operation, connect as described in the JTAG specification (IEEE Std 1149.1). Otherwise, if JTAG is not used, this pin can be left unconnected (NC). This pin is also muxed with UART_TX, which can be enabled by software.
H6	JTAG_TDI	I	For normal operation, connect as described in the JTAG specification (IEEE Std 1149.1). Otherwise, if JTAG is not used, this pin can be left unconnected (NC) as it has an internal weak pull-up resistor. This pin is also muxed with UART_RX, which can be enabled by software.
H7	JTAG_TCK	I	For normal operation, connect as described in the JTAG specification (IEEE Std 1149.1). Otherwise, if JTAG is not used, this pin can be left unconnected (NC) as it has an internal weak pull-up resistor.
G7	JTAG_TRST_L	I	For normal operation, connect as described in the JTAG specification (IEEE Std 1149.1). Otherwise, if JTAG is not used, this pin can be left unconnected (NC) as it has an internal weak pull-up resistor.
<b>JTAG drive strength:</b> For 1.8V: 1.0 mA For 2.5V: 2.5 mA For 3.3V: 3.0 mA Output slewing can be enabled or disabled by software; it is enabled by default.			
<b>Clocks</b>			
A7	WRF_TCXO_IN	I	Reference clock input for use when sharing a TCXO with another chip, such as a BT/FM/GPS chip (see <a href="#">Frequency References on page 9</a> ). This input has an internal DC blocking capacitor, so do not include an external DC blocking capacitor. Connect directly to the external TCXO. This input pad is powered by the WRF_TCXO_VDD3P3 supply, which should be continually powered whenever the external TCXO is powered, even when the CYW43362 is in reset, thereby ensuring this input maintains a constant load on the TCXO signal in all device modes. If unused, ground this pin.
D6	OSCOUT	O	XTAL oscillator amplifier output. See <a href="#">Frequency References on page 9</a> .
D7	OSCIN	I	XTAL oscillator amplifier input. This pin can also be used as the reference clock input from a dedicated (that is, not shared) TCXO.

**Table 7. WLBGA Signal Descriptions (Cont.)**

Ball #	Signal Name	Type	Description
F6	XTAL_PU	O	<p>External reference clock enable (Clock_Request)</p> <p><b>Default mode (open source):</b> XTAL_PU is driven HIGH when the clock is requested and pulled low with a weak internal pull-down resistor when the clock is not requested.</p> <p><b>Push-Pull:</b> Always driven HIGH or LOW (no PU/PD). Push-Pull mode is enabled by software.</p> <p><b>XTAL_PU internal pull-down (PD) resistances:</b></p> <p>PD @ 1.8V (minimum, typical, maximum): 356 k<math>\Omega</math>, 558 k<math>\Omega</math>, 651 k<math>\Omega</math></p> <p>PD @ 2.5V (minimum, typical, maximum): 356 k<math>\Omega</math>, 559 k<math>\Omega</math>, 652 k<math>\Omega</math></p> <p>PD @ 3.3V (minimum, typical, maximum): 356 k<math>\Omega</math>, 559 k<math>\Omega</math>, 653 k<math>\Omega</math></p> <p><b>XTAL_PU drive strength:</b></p> <p>For 1.8V: 2.0 mA</p> <p>For 2.5V: 5.0 mA</p> <p>For 3.3V: 6.0 mA</p> <p>Output slewing can be enabled or disabled by software; it is enabled by default.</p>
J5	EXT_SLEEP_CLK	I	Input pin for optional high-precision 32.768 kHz Clock (Sleep Clock).

Table 7. WLPGA Signal Descriptions (Cont.)

Ball #	Signal Name	Type	Description
<b>GPIO Interface</b>			
E4	GPIO_0	I/O	This pin is used as a strapping option to select SDIO mode (pull low). It is strongly recommended to use GPIO_0 only as a host bus interface select. This pin has a weak internal pull-down resistor.
E5	GPIO_1/BTCX_FREQ	I/O	General-purpose interface pin. This pin is high impedance on power-up and reset. Subsequently, it becomes an input or output through software control. This pin has a programmable weak pull-up/down. This GPIO can be used as the out-of-band WLAN_IRQ signal for SDIO. This pin can also be programmed via software to behave as the BTCX_FREQ coexistence signal.
H5	BTCX_TXCONF/GPIO_3	–	Multiplexed BT_Coex/GPIO pins. When programmed as GPIOs, pins are high impedance on power-up and reset. Subsequently, they can be individually programmed to become inputs or outputs through software control. They can also be programmed to have internal pull-up or pull-down resistors. Only GPIO 1, 3, 4, and 5 (total 4) can be used as GPIOs. GPIO drive strength: For 1.8V: 1.0 mA For 2.5V: 2.5 mA For 3.3V: 3.0 mA Output slewing can be enabled or disabled by software; it is enabled by default.
J6	BTCX_STATUS/GPIO_4	–	
J7	BTCX_RF_ACTIVE/GPIO_5	–	

**Note:**

The following is a list of the internal pull-up/pull-down resistor strengths for the default strapping options described in the GPIO section above:

	Minimum	Typical	Maximum
– pup @ 1.8V	40K	59K	70K
– pdn @ 1.8V	39K	58K	67K
– pup @ 2.5V	40K	58K	69K
– pdn @ 2.5V	39K	58K	67K
– pup @ 3.3V	39K	58K	69K
– pdn @ 3.3V	39K	58K	67K

**Miscellaneous Signals**

J4	WL_RST_N	I	Active low WLAN reset signal. Includes an internal 200 kΩ pull-down resistor. Within 1.5 ms of WL_RST_N being driven high, the PMU changes this from PD to High-Z. Software can optionally enable the pull-down resistor. VIH = 1.08V to 3.6V. VIL < 0.4V.
H5	BTCX_TXCONF/GPIO_3	O	Coexistence output giving Bluetooth permission to transmit. This pin is muxed and can be changed to a GPIO via software.
E5	GPIO_1/BTCX_FREQ	I	By default, this pin behaves as a GPIO. However, it can be programmed via software to behave as a coexistence signal that indicates that the coexisting BT is about to transmit on a restricted channel.
J6	BTCX_STATUS/GPIO_4	I	Coexistence signal indicating Bluetooth priority status and TX/RX direction. This pin is muxed and can be changed to a GPIO via software.
J7	BTCX_RF_ACTIVE/GPIO_5	I	Coexistence signal indicating that Bluetooth is active. This pin is muxed and can be changed to a GPIO via software.

**Note:** The above Bluetooth coexistence and GPIO signals have keepers that prevent them from floating when they aren't connected; however, when they are connected to another component, prevention from floating can't be assured by the keepers.

**Integrated Voltage Regulators**

H1	VOUT_3P3	O	3.3V low noise LDO output (40 mA)
K3	VOUT_LNLD01	O	1.2V output for low noise LDO1, 150 mA
J1, K1	SR_VDDBAT1	I	Battery voltage input for CBUCK
J2	SR_VDDBAT2	I	Battery voltage input for band gap and LDOP3

**Table 7. WLBGA Signal Descriptions (Cont.)**

Ball #	Signal Name	Type	Description
J3	EXT_SMPS_REQ	I	<p>Internal 200 kΩ pull-down resistor included.  <math>V_{IH} = 1.08V</math> to <math>3.6V</math>, and <math>V_{IL} &lt; 0.4V</math>.</p> <p><b>Note:</b> Driving this input high sets CBUCK to External mode, but it does not power down the rest of the PMU. The PMU powers down when WL_RST_N is low.</p> <p><b>Note:</b> This pin is only used if the CYW43362 switching regulator is also used to power an external device. This pin should be connected to ground for applications that do not use this feature.</p>
K4	EXT_PWM_REQ	I	<p>Driving this input high forces CBUCK into PWM mode. Internal 200 kΩ pull-down resistor included.  <math>V_{IH} = 1.08V</math> to <math>3.6V</math>, and <math>V_{IL} &lt; 0.4V</math>.</p> <p><b>Note:</b> This pin is only used if the CYW43362 switching regulator is also used to power an external device. This pin should be connected to ground for applications that do not use this feature.</p>
L1	SR_VLX	O	Core buck regulator: output to inductor
L3	VDD_LDO	I	Input supply pin for CLDO and LNLDO1 (also acts as the voltage feedback for CBUCK).
L4	VOUT_CLDO	O	1.2V output from the core LDO, 150 mA

**Table 7. WLPGA Signal Descriptions (Cont.)**

Ball #	Signal Name	Type	Description
<b>Power Supplies</b>			
B4	WRF_ANA_VDD1P2	I	1.2V analog power supply
A5	WRF_VCO_LDO_IN_VDD1P8	I	1.4V to 1.8V VCO/LDO power supply input
B7	WRF_TCXO_VDD3P3	I	1.7V to 3.3V supply for the CYW43362 TCXO driver. To maintain a constant load on the TCXO_IN pin, even when power is removed from the CYW43362, connect this supply pin to a 1.7V to 3.3V supply that is present whenever the external TCXO is powered up. Note that this should be a clean supply (do not use VIO). If not used, this pin must be connected to ground.
C7	WRF_XTAL_VDD1P2	I	1.2V XTAL oscillator power supply. This supply is required for all clock options: crystal, dedicated TCXO, and shared TCXO (WRF_TCXO_IN).
D1	WRF_PA_VDD	I	Internal power amplifier power supply (VBAT supported), high current
D3	WRF_PADRV_VDD	I	Internal power amplifier driver power supply (VBAT supported)
F7	WRF_AFE_VDD1P2	I	1.2V AFE power supply
H2, H3	VDD	I	1.2V digital supply for the core
G1	VDDIO_RF	I	RF I/O and OTP supply (3.3V)
H4	VDDIO	I	Digital I/O supply.
K5	VDDIO_SD	I	Digital I/O supply for SDIO interface signals.
A3	WRF_LNA_VDD1P2	I	1.2V analog supply to the internal LNA.
C5	WRF_VCO_LDO_OUT_VDD1P2	O	VCO LDO output. Some designs may require a decoupling capacitor (nominal 0.22 $\mu$ F) for optimal WLAN performance. Cypress recommends that a 0201 size footprint for this capacitor be included in all designs in case the capacitor is necessary.
<b>Ground</b>			
D4	WRF_ANA_GND	–	Analog ground
A6	WRF_VCO_GND	–	VCO ground
B2, D2	WRF_PA_GND	–	Internal power amplifier ground
C6	WRF_XTAL_GND	–	XTAL ground
E2	WRF_PADRV_GND	–	Internal power amplifier driver ground
E3, F3, F4, G3, G4	VSS	–	Ground
E6	WRF_AFE_GND	–	AFE ground
K2	PMU_AVSS	–	PMU analog ground
L2	SR_PVSS	–	Buck regulator: power switch ground
A4	WRF_LNA_GND	–	Internal Rx LNA ground
<b>No Connects</b>			
C4	WRF_GPIO_OUT	O	No Connect

**Table 8. CYW43362 During Reset and After Reset or During Sleep**

Signal Name/Group	I/O Type	During Reset		After Reset (and after firmware initialization) or During Sleep	
		Pull R	I/O	Pull R	I/O
<b>Reset/Control</b>					
WL_RST_N	Digital	PD	Input	High Z <sup>a, b</sup>	Input
EXT_SMPS_REQ	Digital	PD	Input	PD <sup>c</sup>	Input
EXT_PWM_REQ	Digital	PD	Input	PD <sup>c</sup>	Input
<b>SDIO Signals</b>					
SDIO_CLK	Digital	None	High Z	None	Input

**Table 8. CYW43362 During Reset and After Reset or During Sleep (Cont.)**

Signal Name/Group	I/O Type	During Reset		After Reset (and after firmware initialization) or During Sleep	
		Pull R	I/O	Pull R	I/O
SDIO_CMD	Digital	None	High Z	PU <sup>d</sup>	Bidirectional
SDIO_DATA0	Digital	None	High Z	PU <sup>d</sup>	Bidirectional
SDIO_DATA1	Digital	None	High Z	PU <sup>d</sup>	Bidirectional
SDIO_DATA2	Digital	None	High Z	PU <sup>d</sup>	Bidirectional
SDIO_DATA3	Digital	None	High Z	PU <sup>d</sup>	Bidirectional
<b>Clock</b>					
XTAL_PU (CLK_REQ)	Digital	PD	High Z	PD <sup>d</sup>	Output (high) <sup>d, e</sup>
EXT_SLEEP_CLK (external 32.768 kHz clock)	Digital	None	High Z	None	Input
OSCIN (reference clock)	CLK	None	High Z	None	Input
<b>Bluetooth Coexistence<sup>f</sup></b>					
btcx_txconf	Digital	None	High Z	Configurable	Output
btcx_freq	Digital	None	High Z	Configurable	Input
btcx_rf_active	Digital	None	High Z	Configurable	Input
btcx_status	Digital	None	High Z	Configurable	Input

**Table 8. CYW43362 During Reset and After Reset or During Sleep (Cont.)**

Signal Name/Group	I/O Type	During Reset		After Reset (and after firmware initialization) or During Sleep	
		Pull R	I/O	Pull R	I/O
<b>RF Switch Control</b>					
rf_sw_ctl_0	Digital	PU	High Z	None	Output
rf_sw_ctl_1	Digital	PD	High Z	None	Output
rf_sw_ctl_2	Digital	PD	High Z	None	Output
rf_sw_ctl_3	Digital	PD	High Z	None	Output
<b>GPIOs<sup>g</sup></b>					
gpio_x	Digital	None	High Z	Configurable	Configurable

- a. Within 1.5 ms of WL\_RST\_N being driven high, the PMU changes this from PD to High-Z.
- b. Software can optionally enable a weak internal pull-down resistor.
- c. Internal pull-down resistor can be disabled via software.
- d. Default mode (Open source): XTAL\_PU is driven HIGH when a clock is requested, and pulled low with a weak internal pull-down resistor when a clock is not requested.  
Push-Pull: Always driven HIGH or LOW (no PU/PD). Available via a strapping option for the FCFBGA and WLCSP packages.
- e. The clock is not requested during Sleep mode.
- f. The Bluetooth coexistence and GPIO signals have keepers that prevent them from floating when they aren't connected; however, when they are connected to another component, prevention from floating can't be assured by the keepers.

## 9.2 WLAN GPIO Signals and Strapping Options

The pins listed in [Table 9](#) are sampled at power-on reset (POR) to determine the various operating modes. Sampling occurs a few milliseconds after an internal POR or deassertion of the external POR. After the POR, each pin assumes the GPIO or alternative function specified in the signal descriptions table. Each strapping option pin has an internal pull-up (PU) or pull-down (PD) resistor that determines the default mode. To change the mode, connect an external PU resistor to VDDIO or a PD resistor to GND, using a 10 kΩ resistor or less.

**Note:** Refer to the reference board schematics for more information.

**Table 9. GPIO Functions and Strapping Options**

Pin Name	WLBGA Pin #	Default	Function	Description
GPIO_0	E4	0	mode_sel	This pin selects the host interface mode: • 0: SDIO

## 10. DC Characteristics

**Note:** Values in this document are design goals and are subject to change based on the results of device characterization.

### 10.1 Absolute Maximum Ratings

**Caution!** The absolute maximum ratings in [Table 10](#) indicate levels where permanent damage to the device can occur, even if these limits are exceeded for only a brief duration. Functional operation is not guaranteed under these conditions. Operation at absolute maximum conditions for extended periods can adversely affect long-term reliability of the device.

**Table 10. Absolute Maximum Ratings**

Rating	Symbol	Value	Unit
DC supply for VBAT	VBAT	-0.5 to 6.0	V
DC supply for WLAN power amplifier	VDDPA	-0.5 to 6.0	V
DC supply voltage for I/O	VDDIO, VDDIO_SD	-0.5 to 4.1	V
DC supply voltage for RF blocks in chip	VDDRF	-0.5 to 1.29	V
DC supply voltage for core	VDD	-0.5 to 1.29	V
DC supply voltage for RF I/Os	VDDIO_RF	-0.5 to 4.1	V
DC input supply voltage for CLDO and LNLDO	-	-0.5 to 2.1	V
WRF_VCO_LDO_IN_VDD1P8	-	-0.5 to 2.75	V
WRF_TCXO_VDD3P3	-	-0.5 to 3.63	V
WL_RST_N	-	-0.5 to 3.63	V
EXT_SMPS_REQ	-	-0.5 to 3.63	V
EXT_PWM_REQ	-	-0.5 to 3.63	V
Maximum undershoot voltage for I/O	V <sub>undershoot</sub>	-0.5	V
Maximum overshoot voltage for I/O	V <sub>overshoot</sub>	VDDIO + 0.5	V
Maximum Junction Temperature	T <sub>j</sub>	125	°C

### 10.2 Environmental Ratings

The environmental ratings are shown in [Table 11](#).

**Table 11. Environmental Ratings**

Characteristic	Value	Units	Conditions/Comments
Ambient Temperature (T <sub>A</sub> )	-30 to +85°C	°C	Operation
Storage Temperature	-40 to +125°C	°C	-
Relative Humidity	Less than 60	%	Storage
	Less than 85	%	Operation

### 10.3 Electrostatic Discharge Specifications

Extreme caution must be exercised to prevent electrostatic discharge (ESD) damage. Proper use of wrist and heel grounding straps to discharge static electricity is required when handling these devices. Always store unused material in its antistatic packaging.

**Table 12. ESD Specifications**

Pin Type	Symbol	Condition	ESD Rating	Unit
ESD, Handling Reference: NQY00083, Section 3.4, Group D9, Table B	ESD_HAND_HBM	Human Body Model Contact Discharge per JEDEC EID/JESD22-A114	1250	V
Machine Model (MM)	ESD_HAND_MM	Machine Model Contact	50	V

**Table 12. ESD Specifications**

Pin Type	Symbol	Condition	ESD Rating	Unit
CDM	ESD_HAND_CDM	Charged Device Model Contact Discharge per JEDEC EIA/JESD22-C101	175	V

**10.4 Recommended Operating Conditions and DC Characteristics**

Functional operation is not guaranteed outside the limits shown in Table 13, and operation outside these limits for extended periods can adversely affect long-term reliability of the device.

**Table 13. Recommended Operating Conditions and DC Characteristics**

Element	Symbol	Value			Unit
		Minimum	Typical	Maximum	
DC supply voltage for VBAT	VBAT	2.3	–	4.8 <sup>a</sup>	V
DC supply for WLAN power amplifier	VDDPA	2.3	3.3	4.8 <sup>a</sup>	V
DC supply voltage for core	VDD	1.14	1.2	1.26	V
DC Supply voltage for RF blocks in chip	VDDRF	1.14	1.2	1.26	V
DC supply voltage for I/O	VDDIO, VDDIO_SD	1.71	–	3.63	V
DC supply voltage for RF I/Os	VDDIO_RF	3.13	3.3	3.46	V
WRF_VCO_LDO_IN_VDD1P8	–	1.4	1.8	1.9	V
WRF_TCXO_VDD3P3 (I <sub>cc</sub> = 500 μA max) <sup>b,c</sup>	–	1.7	1.8	3.3	V
Input high voltage (WL_RST_N, EXT_SMPS_REQ, EXT_PWM_REQ)	V <sub>IH</sub>	1.08	–	3.6	V
Input low voltage (WL_RST_N, EXT_SMPS_REQ, EXT_PWM_REQ)	V <sub>IL</sub>	–	–	0.4	V
Input high voltage (VDDIO = 1.8V) <sup>d</sup>	V <sub>IH</sub>	1.1	–	VDDIO	V
Input low voltage (VDDIO = 1.8V) <sup>c</sup>	V <sub>IL</sub>	–	–	0.7	V
Input high voltage (VDDIO = 2.5V) <sup>c</sup>	V <sub>IH</sub>	1.7	–	VDDIO	V
Input low voltage (VDDIO = 2.5V) <sup>c</sup>	V <sub>IL</sub>	–	–	0.8	V
Input high voltage (VDDIO = 3.3V) <sup>c</sup>	V <sub>IH</sub>	2.0	–	VDDIO	V
Input low voltage (VDDIO = 3.3V) <sup>c</sup>	V <sub>IL</sub>	–	–	0.8	V
SDIO input high voltage (VDDIO_SD = 1.8V)	V <sub>IH</sub>	1.17	–	VDDIO_SD	V
SDIO input low voltage (VDDIO_SD = 1.8V)	V <sub>IL</sub>	–	–	0.63	V
SDIO input high voltage (VDDIO_SD = 2.5V or 3.3V)	V <sub>IH</sub>	2.0	–	VDDIO_SD	V
SDIO input low voltage (VDDIO_SD = 2.5V or 3.3V)	V <sub>IL</sub>	–	–	0.8	V
Output low voltage <sup>e</sup>	V <sub>OL</sub>	–	–	0.4	V
Output high voltage <sup>d</sup>	V <sub>OH</sub>	VDDIO – 0.4V	–	–	V
Input low current	I <sub>IL</sub>	–	0.3	–	μA
Input high current	I <sub>IH</sub>	–	0.3	–	μA

- a. The maximum continuous supply voltage is 4.8V. Brief spikes above this 4.8V can be tolerated. Specifically, voltages as high as 5.5V for up to 10 seconds cumulative duration over the lifetime of the device are allowed. Voltages as high as 5.0V for up to 250 seconds cumulative duration over the lifetime of the device are allowed.
- b. The maximum limits for TCXO\_VDD3P3 noise are: 20 kHz, 100 nV/sqrt(Hz); 100 kHz, 80 nV/sqrt(Hz); 1 MHz, 50 nV/sqrt(Hz); 2 MHz, 30 nV/sqrt(Hz)
- c. Conditions for I<sub>cc</sub> = 500 μA maximum are: –30°C, 3.3V, 52 MHz.
- d. For non-SDIO digital I/O only.
- e. For SDIO and non-SDIO outputs.

## 11. WLAN RF Specifications

The CYW43362 includes an integrated direct conversion radio that supports the 2.4 GHz band. This section describes the RF characteristics of the 2.4 GHz radio.

**Note:** Values in this document are design goals and may change based on device characterization results.

Unless otherwise stated, the specifications in this section apply when the operating conditions are within the limits specified in Table 11, “Environmental Ratings,” on page 32 and Table 13, “Recommended Operating Conditions and DC Characteristics,” on page 33. Functional operation outside these limits is not guaranteed.

Typical values apply for the following conditions:

- VBAT = 3.6V
- Ambient temperature +25°C

**Figure 16. RF Port Location**

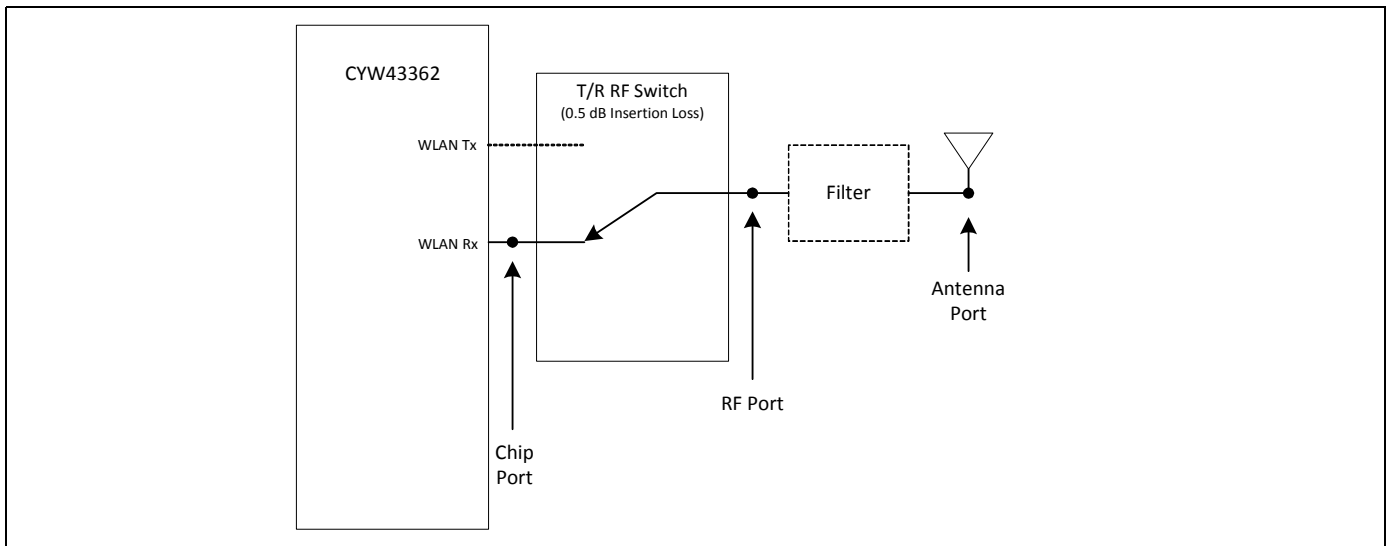

**Note:** All specifications are measured at the RF port unless otherwise specified.

### 11.1 2.4 GHz Band General RF Specifications

**Table 14. 2.4 GHz Band General RF Specifications**

Item	Condition	Minimum	Typical	Maximum	Unit
Tx/Rx switch time	Including TX ramp down	–	–	5	µs
Rx/Tx switch time	Including TX ramp up	–	–	2	µs

### 11.2 WLAN 2.4 GHz Receiver Performance Specifications

**Note:** The specifications in Table 15 are measured at the RF port.

**Table 15. WLAN 2.4 GHz Receiver Performance Specifications**

Parameter	Condition/Notes	Minimum	Typical	Maximum	Unit
Frequency range	–	2400	–	2500	MHz
Operating temperature	–	–30	25	85	°C

Table 15. WLAN 2.4 GHz Receiver Performance Specifications (Cont.)

Parameter	Condition/Notes	Minimum	Typical	Maximum	Unit	
RX sensitivity (8% PER for 1024 octet PSDU) at WLAN RF port <sup>a</sup>	1 Mbps DSSS	-95	-97	-	dBm	
	2 Mbps DSSS	-92.5	-94.5	-	dBm	
	5.5 Mbps DSSS	-90	-92	-	dBm	
	11 Mbps DSSS	-87	-89	-	dBm	
RX sensitivity (10% PER for 1000 octet PSDU) at WLAN RF port <sup>a</sup>	6 Mbps OFDM	-88	-90	-	dBm	
	9 Mbps OFDM	-88	-90	-	dBm	
	12 Mbps OFDM	-86	-88	-	dBm	
	18 Mbps OFDM	-84	-86	-	dBm	
	24 Mbps OFDM	-82	-84	-	dBm	
	36 Mbps OFDM	-79	-81	-	dBm	
	48 Mbps OFDM	-75	-77	-	dBm	
	54 Mbps OFDM	-73	-75	-	dBm	
RX sensitivity (10% PER for 4096 octet PSDU) at WLAN RF port <sup>a</sup> . Defined for default parameters: GF, 800 ns GI, and non-STBC.	20 MHz channel spacing for all MCS rates					
	MCS7		-70	-72	-	dBm
	MCS6		-72.5	-74.5	-	dBm
	MCS5		-74.5	-76.5	-	dBm
	MCS4		-78.5	-80.5	-	dBm
	MCS3		-82	-84	-	dBm
	MCS2		-84.5	-86.5	-	dBm
	MCS1		-86.5	-88.5	-	dBm
Blocking level @ WLAN RF port for 1dB Rx sensitivity degradation (without external filtering). <sup>b</sup>	698–716 MHz	WCDMA, LTE	-28	-	-	dBm
	776–787 MHz	WCDMA, LTE	-28	-	-	dBm
	824–849 MHz	GSM850	-19 <sup>c</sup>	-	-	dBm
	824–849 MHz	WCDMA, LTE	-28 <sup>d</sup>	-	-	dBm
	880–915 MHz	GSM900	-19	-	-	dBm
	880–915 MHz	WCDMA, LTE	-28	-	-	dBm
	1710–1785 MHz	GSM1800	-22	-	-	dBm
	1710–1785 MHz	WCDMA, LTE	-28	-	-	dBm
	1850–1910 MHz	GSM1900	-22	-	-	dBm
	1850–1910 MHz	WCDMA, LTE	-28	-	-	dBm
	1880–1920 MHz	TD-SCDMA	-33	-	-	dBm
	1900–1920 MHz	LTE	-28	-	-	dBm
	1910–1930 MHz	LTE	-28	-	-	dBm
	1920–1980 MHz	WCDMA, LTE	-28	-	-	dBm
	1930–1990 MHz	LTE	-32	-	-	dBm
	2010–2025 MHz	TD-SCDMA	-31	-	-	dBm
	2500–2570 MHz	WCDMA, LTE	-50	-	-	dBm
	2570–2620 MHz	LTE	-50	-	-	dBm
	3168–4752 MHz	UWB	-28	-	-	dBm
	3402–3620 MHz	WiMAX	-23	-	-	dBm
6336–8976 MHz	UWB	-21	-	-	dBm	
Maximum Receive Level @ 2.4 GHz	@ 1, 2 Mbps (8% PER, 1024 octets)		-3.5	-	-	dBm
	@ 5.5, 11 Mbps (8% PER, 1024 octets)		-9.5	-	-	dBm
	@ 6–54 Mbps (10% PER, 1000 octets)		-13	-	-	dBm

Table 15. WLAN 2.4 GHz Receiver Performance Specifications (Cont.)

Parameter	Condition/Notes		Minimum	Typical	Maximum	Unit
LPF 3-dB Bandwidth	–	–	9	–	10	MHz
Adjacent channel rejection-DSSS (Difference between interfering and desired signal [25 MHz apart] at 8% PER for 1024 octet PSDU with desired signal level as specified in Condition/Notes)	11 Mbps DSSS	–70 dBm	35	–	–	dB
Adjacent channel rejection-OFDM (Difference between interfering and desired signal (25 MHz apart) at 10% PER for 1000 <sup>e</sup> octet PSDU with desired signal level as specified in Condition/Notes)	6 Mbps OFDM	–79 dBm	16	–	–	dB
	9 Mbps OFDM	–78 dBm	15	–	–	dB
	12 Mbps OFDM	–76 dBm	13	–	–	dB
	18 Mbps OFDM	–74 dBm	11	–	–	dB
	24 Mbps OFDM	–71 dBm	8	–	–	dB
	36 Mbps OFDM	–67 dBm	4	–	–	dB
	48 Mbps OFDM	–63 dBm	0	–	–	dB
	54 Mbps OFDM	–62 dBm	–1	–	–	dB
	65 Mbps OFDM	–61 dBm	–2	–	–	dB
Maximum receiver gain	–	–	–	90	–	dB
Gain control step	–	–	–	3	–	dB
RCPI accuracy <sup>f</sup>	Range –98 dBm to –75 dBm		–3	–	3	dB
	Range above –75 dBm		–5	–	5	dB
Return loss	Zo = 50 across the dynamic range.		10	–	–	dB

- a. Derate by 1.5 dB for –30 °C to –10°C and 55°C to 85°C.
- b. The cellular standard listed for each band indicates the type of modulation used to generate the interfering signal in that band for the purpose of this test. It is not intended to indicate any specific usage of each band in any specific country.
- c. Min value is –23 dB for chan 11.
- d. Min value is –36 dBm for chan 11.
- e. For 65 Mbps, the size is 4096.
- f. The minimum and maximum values shown have a 95% confidence level.

### 11.3 WLAN 2.4 GHz Transmitter Performance Specifications

Note: The specifications in Table 16 are measured at the RF port output.

Table 16. WLAN 2.4 GHz Transmitter Performance Specifications

Parameter	Condition/Notes		Minimum	Typical	Maximum	Unit
Frequency range	–		2400	–	2500	MHz
Transmitted power in cellular and FM bands at RF port (at 18.5 dBm, 90% duty cycle, 1 Mbps CCK). <sup>a</sup>	76–108 MHz	FM RX	–	–161	–159	dBm/Hz
	170–240 MHz	DAB	–	–161	–159	dBm/Hz
	470–862 MHz	DVB-H	–	–161	–159	dBm/Hz
	728–746 MHz	WCDMA, LTE	–	–161	–159	dBm/Hz
	746–757 MHz	WCDMA, LTE	–	–161	–159	dBm/Hz
	869–894 MHz	WCDMA, LTE	–	–161	–159	dBm/Hz
	925–960 MHz	GSM, WCDMA, LTE	–	–161	–159	dBm/Hz
	1570–1580 MHz	GPS	–	–155	–153	dBm/Hz
	1592–1610 MHz	GLONASS	–	–155	–153	dBm/Hz
	1805–1880 MHz	GSM, WCDMA, LTE	–	–155	–153	dBm/Hz
	1880–1920 MHz	TD-SCDMA	–	–134	–132	dBm/Hz
	1850–1910 MHz	WCDMA, LTE	–	–134	–132	dBm/Hz
	1910–1930 MHz	WCDMA, LTE	–	–134	–132	dBm/Hz
	1900–1920 MHz	WCDMA, LTE	–	–134	–132	dBm/Hz
	1930–1990 MHz	GSM, WCDMA, LTE	–	–134	–132	dBm/Hz
2010–2075 MHz	TD-SCDMA	–	–125.3	–123.3	dBm/Hz	
2110–2170 MHz	WCDMA, LTE	–	–125.3	–123.3	dBm/Hz	
Harmonic level at RF port (at 18 dBm with 90% duty cycle, 1 Mbps CCK)	4.8–5.0 GHz	2nd harmonic	–	–19.5	–12.8	dBm/ MHz
	7.2–7.5 GHz	3rd harmonic	–	–37.7	–26.7	dBm/ MHz
Tx power at RF port for highest power level setting at 25°C, VBAT = 3.6V and spectral mask and EVM compliance <sup>b, c</sup>	<b>EVM Does Not Exceed</b>					
	IEEE 802.11b (DSSS/CCK)	–9 dB	18.5	–	–	dBm
	OFDM, BPSK	–8 dB	18	–	–	dBm
	OFDM, QPSK	–13 dB	18	–	–	dBm
	OFDM, 16-QAM	–19 dB	18	–	–	dBm
	OFDM, 64-QAM (R = 3/4)	–25 dB	15.5	–	–	dBm
OFDM, 64-QAM (R = 5/6)	–28 dB	14.5	–	–	dBm	
Tx power control dynamic range	–		9	–	–	dB
Closed loop Tx power variation at highest power level setting (at RF port)	Across full temperature and voltage range. Applies across 5 to 21 dBm output power range.		–	–	±1.5	dB
Carrier suppression	–		15	–	–	dBc
Gain control step	–		–	0.25	–	dB
Return loss	Zo = 50		4	6	–	dB
Load pull variation for output power, EVM, and Adjacent Channel Power Ratio (ACPR)	VSWR = 2:1.	EVM degradation	–	3.5	–	dB
		Output power variation	–	±2	–	dB
		ACPR-compliant power level	–	15	–	dBm
	VSWR = 3:1.	EVM degradation	–	4	–	dB
		Output power variation	–	±3	–	dB
		ACPR-compliant power level	–	15	–	dBm

- a. The cellular standards listed indicate only typical usages of that band in some countries. Other standards may also be used within those bands.
- b. Derate by 1.5 dB for temperatures less than  $-10^{\circ}\text{C}$  or more than  $55^{\circ}\text{C}$ , or voltages less than 3.0V. Derate by 3.0 dB for voltages of less than 2.7V or voltages of less than 3.0V at temperatures less than  $-10^{\circ}\text{C}$  or greater than  $55^{\circ}\text{C}$ .
- c. Tx power for Ch 1 and Ch 11 is specified separately by nonvolatile memory parameters to ensure band-edge compliance.

## 11.4 General Spurious Emissions Specifications

**Table 17. General Spurious Emissions Specifications**

Parameter	Condition/Notes		Minimum	Typical	Maximum	Unit
Frequency range	–		2400	–	2500	MHz
<b>General Spurious Emissions</b>						
Tx Emissions	$30\text{ MHz} < f < 1\text{ GHz}$	RBW = 100 kHz	–	–99	–96	dBm
	$1\text{ GHz} < f < 12.75\text{ GHz}$	RBW = 1 MHz	–	–44	–41	dBm
	$1.8\text{ GHz} < f < 1.9\text{ GHz}$	RBW = 1 MHz	–	–68	–65	dBm
	$5.15\text{ GHz} < f < 5.3\text{ GHz}$	RBW = 1 MHz	–	–88	–85	dBm
Rx/standby Emissions	$30\text{ MHz} < f < 1\text{ GHz}$	RBW = 100 kHz	–	–99	–96	dBm
	$1\text{ GHz} < f < 12.75\text{ GHz}$	RBW = 1 MHz	–	–54	–51	dBm
	$1.8\text{ GHz} < f < 1.9\text{ GHz}$	RBW = 1 MHz	–	–88	–85	dBm
	$5.15\text{ GHz} < f < 5.3\text{ GHz}$	RBW = 1 MHz	–	–88	–85	dBm

**Note:** The specifications in this table are at the RF port.

## 12. Internal Regulator Electrical Specifications

**Note:** Values in this document are design goals and are subject to change based on the results of device characterization. Functional operation is not guaranteed outside the specification limits provided in this section.

### 12.1 Core Buck Regulator

The specifications for the Core Buck regulator (CLOCK) are provided in [Table 18](#).

**Table 18. Core Buck Regulator**

Specification	Notes	Minimum	Typical	Maximum	Units
Input supply voltage	–	2.3	–	4.8 <sup>a</sup>	Volts
PWM mode switching frequency	–	2.56	3.2	3.84	MHz
PWM output current	–	–	–	500	mA
Output current limit	–	–	700	–	mA
Output voltage range	Programmable, 33.33 mV steps default = 1.8V	1.2	–	1.833	Volts
Output voltage DC accuracy	Includes load and line regulation. VBAT = 2.7V to 4.8V, Load 0 to 500 mA, Inductor DCR < 137.5 mΩ	–5	–	5	%
PWM ripple voltage, static <sup>b</sup>	Measure with 20 MHz BW limit. Fixed load (0 to 500 mA). Max ripple based on VBAT < 4.3V, Vout = 1.833V, Fs = 3.2 MHz, 1.5 μH inductor L > 0.6144 μH, Cap+Board total-ESR < 10 mΩ, Cout > 1.9 μF	–	7	20	mVpp
PWM load step transient voltage error	VBAT = 2.7V to 4.8V, current step = 150 to 400 mA, 1 μsec rise-time based on 0402, 6.3V, X5R, and 4.7 μF <sup>c</sup> ceramic capacitor.	–	100	200	mV
PWM line step transient voltage error	VBAT step from 2.3 to 2.7V, 10 μsec rise-time, fixed 500 mA load based on 0402, 6.3V, X5R, and 4.7 μF <sup>b</sup> ceramic capacitor.	–	50	100	mV
PWM load regulation <sup>a</sup>	VBAT = 2.7V to 4.8V, 10 mA to 500 mA load. Inductor DCR < 137.5 mΩ	–	–	±30	mV
PWM line regulation <sup>a</sup>	VBAT = 2.7V to 4.8V, 500 mA load. Inductor DCR < 137.5 mΩ	–	–	±10	mV
Burst mode ripple voltage, static	Load < 30 mA. Measure with 20 MHz BW limit.	–	–	80	mVpp
	30 mA < Load < 200 mA. Measure with 20 MHz BW limit.	–	–	200	mVpp
Burst mode load step transient voltage error	VBAT = 2.7V to 4.8V, current step 10 to 200 mA, 1 μsec rise-time based on 0402, 6.3V, X5R, and 4.7 μF <sup>b</sup> ceramic capacitor.	–	60	120	mV
Burst mode line step transient voltage error	VBAT step from 2.3V to 2.7V, 10 μsec rise-time, fixed 200 mA load based on 0402, 6.3V, X5R, and 4.7 μF <sup>b</sup> ceramic capacitor.	–	50	100	mV
Burst mode load regulation	VBAT = 2.7V to 4.8V, 10 mA to 200 mA load	–	35	50	mV
Burst line regulation	Input voltage 2.7 to 4.8V, 200 mA load	–	44	70	mV
Peak PWM mode efficiency <sup>d</sup>	200 mA load current	80	90	–	%
	30 mA load current	60	–	–	%
Burst mode efficiency	5 mA load current	70	80	–	%

**Table 18. Core Buck Regulator (Cont.)**

Specification	Notes	Minimum	Typical	Maximum	Units
Start-up time from power down	–	–	1350	1500	μs
Burst to PWM mode transient voltage error	Ensure load current < 200 mA during a mode change	–	–	160	mV
External inductor	See preferred inductor list	–	1.5	–	μH
External output capacitor	Ceramic, X5R, 0402, Cap-ESR < 4 mΩ ESL < 700 pH at 3.2 MHz, ±20%, 6.3V	–	4.7	–	μF
External input capacitor	For SR_VDDBAT1 pins, ceramic, X5R, 0603, Cap-ESR < 4 mΩ at 3.2 MHz, ±10%, 6.3V	–	4.7	–	μF
Input supply voltage ramp-up time	0 to 4.3V	40	–	–	μs

- The maximum continuous supply voltage is 4.8V. Brief spikes above this 4.8V can be tolerated. Specifically, voltages as high as 5.5V for up to 10 seconds cumulative duration over the lifetime of the device are allowed. Voltages as high as 5.0V for up to 250 seconds cumulative duration over the lifetime of the device are allowed.
- These are not load or line step transient tests.
- More capacitance can be used to reduce the transient error at the output.
- VBAT < 4.3V. Inductor DCR < 137.5 mΩ, ACR < 1Ω.

An efficiency plot for the CBUCK regulator is shown in [Figure 17](#). The plot shows typical performance for nominal process silicon, Vout = 1.8V, VBAT = 3.6V, and temperature = 25°C.

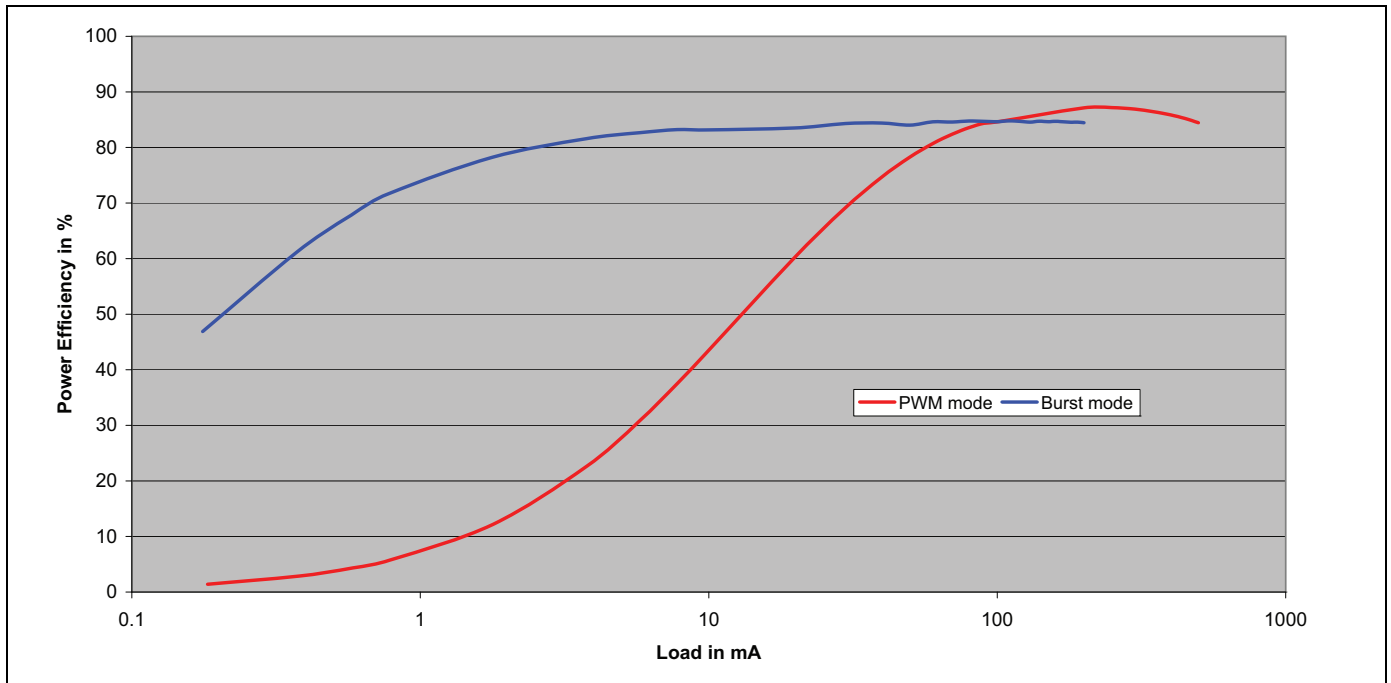
**Figure 17. CBUCK Efficiency**

## 12.2 3.3V LDO (LDO3P3)

**Table 19. 3.3V LDO (LDO3P3)**

Specification	Notes	Minimum	Typical	Maximum	Units
Input supply voltage	–	2.3	3.6	4.8 <sup>a</sup>	Volts
Output current	–	–	–	40	mA
Output voltage, Vo	Step size 100 mV. Default = 3.3V.	2.4	3.3	3.4	Volts
Dropout voltage	At max load	–	–	200	mV
Output voltage DC accuracy	Include line/load regulation.	–5	–	+5	%
Quiescent current	No load	–	8	17	μA
Line regulation	Vin from (Vo + 0.2V) to 4.8V, maximum load	–0.2	–	+0.2	%Vo/V
Load regulation	Load from 1 mA to 40 mA	–	0.02	0.05	%Vo/mA
Leakage current	Power-down mode	–	–	5	μA
PSRR	V <sub>BAT</sub> ≥ 3.6V, V <sub>o</sub> = 2.5V, C <sub>o</sub> = 1 μF, max load, 100 Hz to 1 MHz	20	–	–	dB
Start-up time	From the rising edge of V <sub>IO</sub> as the chip powers up from a full power down (that is, band gap off)	–	1200	1400	μs
LDO turn-on time	LDO turn-on time when rest of chip is up	–	–	100	μs
In-rush current during turn-on	From its output capacitor in fully discharged state	–	–	135	mA
External output capacitor, Co	Ceramic, X5R, 0402, (ESR: 30 mΩ–200 mΩ), ±10%, 10V	–	1	–	μF
External input capacitor	For SR_VDDBAT2 pin (shared with Band gap) Ceramic, X5R, 0603, (ESR: 30 mΩ–200 mΩ), ±10%, 10V	–	1	–	μF

a. The maximum continuous supply voltage is 4.8V. Brief spikes above this 4.8V can be tolerated. Specifically, voltages as high as 5.5V for up to 10 seconds cumulative duration over the lifetime of the device are allowed. Voltages as high as 5.0V for up to 250 seconds cumulative duration over the lifetime of the device are allowed.

## 12.3 CLDO

**Table 20. CLDO**

Specification	Notes	Minimum	Typical	Maximum	Units
Input supply voltage, Vin	Min = 1.25 + 0.2V = 1.45V. Dropout voltage requirement must be met under max load.	1.45	1.5	2.0	Volts
Output current	–	–	–	150	mA
Output voltage, Vo	Programmable in 25 mV steps	1.075	1.2	1.325	Volts
Dropout voltage	At max load	–	–	200	mV
Output voltage DC accuracy	Include line/load regulation Vin > Vo + 0.2V	–4	–	+4	%
Quiescent current	No-load	–	10	15	μA
Line regulation	Vin from (Vo + 0.2V) to 2V, max load	–0.2	–	+0.2	%Vo/V
Load regulation	Load from 1 mA to 150 mA	–	0.02	0.05	%Vo/mA
Leakage current	Power-down	–	–	10	μA

**Table 20. CLDO**

Specification	Notes	Minimum	Typical	Maximum	Units
PSRR	@1 kHz, $V_{in} \geq 1.5V$ , $C_o = 1-2.2 \mu F$	20	40	–	dB
Start-up time	From full-chip power down <sup>a</sup>	–	1250	1400	$\mu s$
LDO turn-on time	LDO turn-on time when rest of chip is up	–	–	180	$\mu s$
In-rush current during turn-on	From its output capacitor in fully discharged state	–	–	150	mA
External output capacitor, $C_o$ (nominal values)	Ceramic, X5R, 0402, (ESR: 30 m $\Omega$ –200 m $\Omega$ ), $\pm 10\%$ , 10V	–	2.2	–	$\mu F$
External input capacitor (nominal values)	Only use an external input cap at VDD_LDO pin if it is not supplied from CBUCK output. Ceramic, X5R, 0402, (ESR: 30 m $\Omega$ – 200 m $\Omega$ ), $\pm 10\%$ , 10V	–	1	2.2	$\mu F$

a. With CBUCK soft-starting concurrently.

## 12.4 LNLDO1

**Table 21. LNLDO1**

Specification	Notes	Minimum	Typical	Maximum	Units
Input supply voltage, $V_{in}$	Min = $1.25 + 0.2V = 1.45V$ Dropout voltage requirement must be met under max load.	1.45	1.5	2.0	Volts
Output current	–	–	–	150	mA
Output voltage, $V_o$	Programmable in 25 mV steps	1.075	1.2	1.325	Volts
Dropout voltage	At max load	–	–	200	mV
Output voltage DC accuracy	Include line/load regulation $V_{in} > V_o + 0.2V$	–4	–	+4	%
Quiescent current	No-load	–	31	44	$\mu A$
Line regulation	$V_{in}$ from ( $V_o + 0.2V$ ) to 2V, max load	–0.2	–	+0.2	% $V_o/V$
Load regulation	Load from 1 mA to 150 mA	–	0.02	0.05	% $V_o/mA$
Leakage current	Power-down	–	–	10	$\mu A$
Output noise	@30 kHz, 60 mA load $C_o = 2.2 \mu F$ @100 kHz, 60 mA load $C_o = 2.2 \mu F$	–	–	60 30	nV/rt Hz nV/rt Hz
PSRR	@1 kHz, $V_{in} \geq 1.5V$ , $C_o = 2.2 \mu F$	20	50	–	dB
LDO turn-on time	LDO turn-on time when rest of chip is up	–	–	180	$\mu s$
In-rush current during turn-on	From its output capacitor in fully discharged state	–	–	150	mA
External output capacitor, $C_o$ (nominal values)	Ceramic, X5R, 0402, (ESR: 30 m $\Omega$ –200 m $\Omega$ ), $\pm 10\%$ , 10V	–	2.2	–	$\mu F$

**Note:** Recommended inductor for CBUCK:  $1.5 \mu H \pm 20\%$ .  
Murata® LQM21PN1R5MC0 2.0 × 1.25 × 0.55 mm DCR =  $0.26 \Omega \pm 25\%$ .  
Murata LQM2MPN1R5NG0 2.0 × 1.60 × 1.00 mm DCR =  $0.11 \Omega \pm 25\%$ .

### 13. System Power Consumption

**Note:** Table 22 shows typical values.

Power consumption referenced to VBAT @ 3.6V, 20°C, VDDIO = 1.8V, CBUCK out = 1.5V.

**Table 22. System Power Consumption**

WLAN Operational Modes	Total (Ivbat)
OFF <sup>1</sup>	11 $\mu$ A
OFF <sup>2</sup>	40 $\mu$ A
IDLE	185 $\mu$ A
SLEEP <sup>5</sup>	200 $\mu$ A
Rx (Listen) <sup>3</sup>	52 mA
Rx (Active) <sup>4</sup>	59 mA
Power Save <sup>6, 9</sup>	1.9 mA
Tx CCK (11 Mbps at 18.5 dBm) <sup>7, 11</sup>	320 mA
Tx OFDM (54 Mbps at 15.5 dBm) <sup>8, 11</sup>	270 mA
Tx OFDM (65 Mbps at 14.5 dBm) <sup>10, 11</sup>	260 mA
<p>Note 1: WL_RST_N = Low, VDDIO is not present            Note 2: WL_RST_N = Low, VDDIO is present            Note 3: Carrier Sense (CCA) when no carrier present            Note 4: Carrier Sense (CS) detect/ Packet Rx            Note 5: Intra-beacon Sleep            Note 6: Beacon Interval = 102.4 ms, DTIM = 1, Beacon duration = 1 ms @1 Mbps.            Integrated Sleep + wakeup + Beacon Rx current over 1 DTIM interval.            Note 7: CCK power at chip port. Duty cycle is 100%. Includes PA contribution at 3.6V.            Note 8: OFDM power at chip port. Duty cycle is 100%. Includes PA contribution at 3.6V.            Note 9: In WLAN power-saving mode, the following blocks are powered down: Crystal oscillator, Baseband PLL, AFE, RF PLL, Radio            Note 10: OFDM power at chip port is 16 dBm, duty cycle is 100%, includes PA contribution at 3.6V.            The above blocks are turned ON in the required order with sufficient time for them to settle. This sequencing is done by the PMU controller that controls the settling time for each of the blocks. It also has information to determine the order in which the blocks should be turned ON. The settling times and the dependency order are programmable in the PMU controller. The default CLK settling time is set to 8 ms at power-up. It can be reduced after power-up.            Note 11: Absolute junction temperature limits maintained through active thermal monitoring and dynamic Tx duty cycle limiting.</p>	

## 14. Interface Timing and AC Characteristics

**Note:** Values in this document are design goals and are subject to change based on the results of device characterization.

Unless otherwise stated, the specifications in this section apply when the operating conditions are within the limits specified in Table 11 on page 32 and Table 13 on page 33. Functional operation outside of these limits is not guaranteed.

### 14.1 SDIO Default Mode Timing

SDIO default mode timing is shown by the combination of Figure 18 and Table 23 on page 44.

**Figure 18. SDIO Bus Timing (Default Mode)**

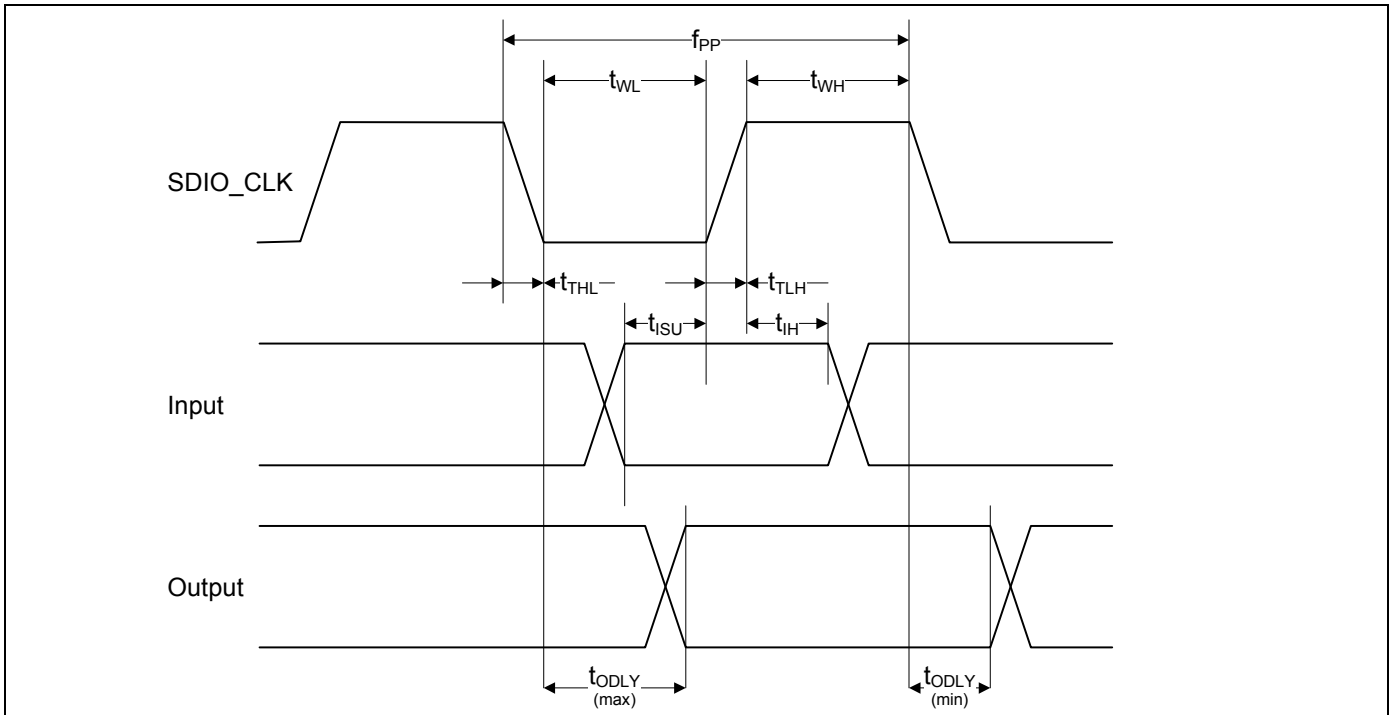

**Table 23. SDIO Bus Timing <sup>a</sup> Parameters (Default Mode)**

Parameter	Symbol	Minimum	Typical	Maximum	Unit
<b>SDIO CLK (All values are referred to minimum VIH and maximum VIL<sup>b</sup>)</b>					
Frequency—Data Transfer mode	$f_{PP}$	0	–	25	MHz
Frequency—Identification mode	$f_{OD}$	0	–	400	kHz
Clock low time	$t_{WL}$	10	–	–	ns
Clock high time	$t_{WH}$	10	–	–	ns
Clock rise time	$t_{TLH}$	–	–	10	ns
Clock fall time	$t_{THL}$	–	–	10	ns
<b>Inputs: CMD, DAT (referenced to CLK)</b>					
Input setup time	$t_{ISU}$	5	–	–	ns
Input hold time	$t_{IH}$	5	–	–	ns
<b>Outputs: CMD, DAT (referenced to CLK)</b>					
Output delay time—Data Transfer mode	$t_{ODLY}$	0	–	14	ns

**Table 23. SDIO Bus Timing <sup>a</sup> Parameters (Default Mode)**

Parameter	Symbol	Minimum	Typical	Maximum	Unit
Output delay time—Identification mode	tODLY	0	–	50	ns

- a. Timing is based on  $CL \leq 40$  pF load on CMD and Data.
- b.  $\min(V_{ih}) = 0.7 \times VDDIO$  and  $\max(V_{il}) = 0.2 \times VDDIO$ .

**14.2 SDIO High-Speed Mode Timing**

SDIO high-speed mode timing is shown by the combination of Figure 19 and Table 24.

**Figure 19. SDIO Bus Timing (High-Speed Mode)**

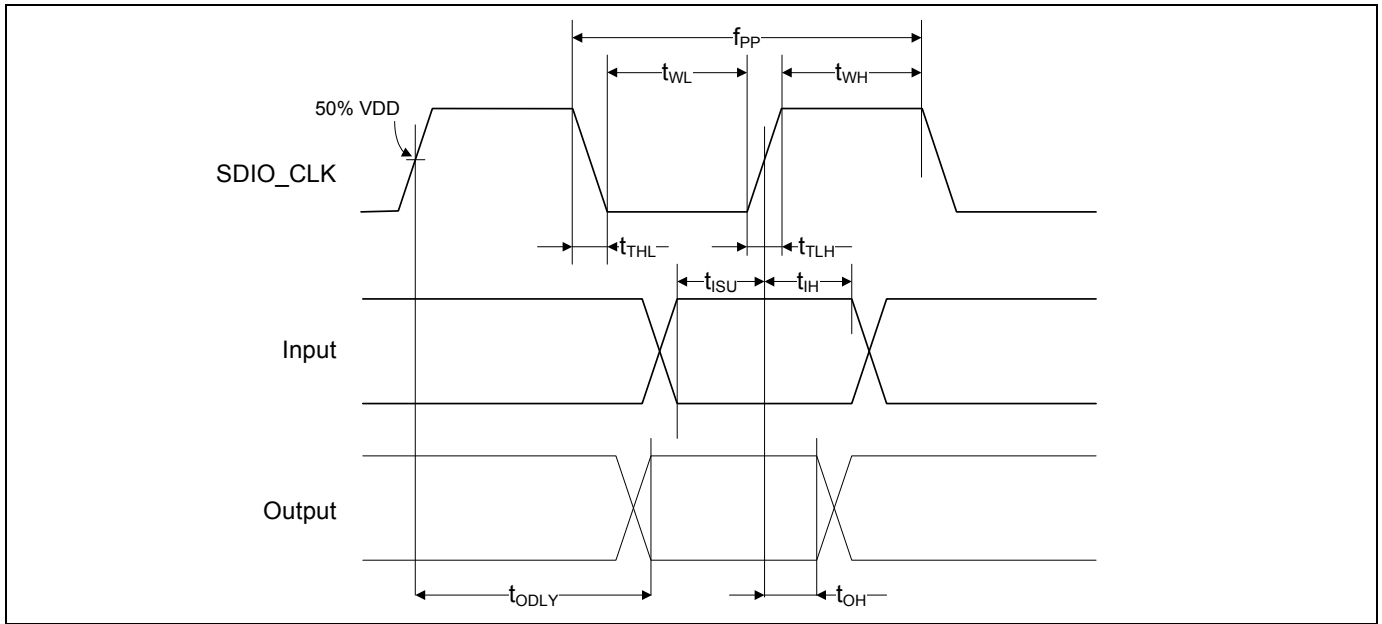

**Table 24. SDIO Bus Timing <sup>a</sup> Parameters (High-Speed Mode)**

Parameter	Symbol	Minimum	Typical	Maximum	Unit
<b>SDIO CLK (all values are referred to minimum <math>V_{IH}</math> and maximum <math>V_{IL}</math><sup>b</sup>)</b>					
Frequency – Data Transfer Mode	fPP	0	–	50	MHz
Frequency – Identification Mode	fOD	0	–	400	kHz
Clock low time	tWL	7	–	–	ns
Clock high time	tWH	7	–	–	ns
Clock rise time	tTLH	–	–	3	ns
Clock fall time	tTHL	–	–	3	ns
<b>Inputs: CMD, DAT (referenced to CLK)</b>					
Input setup Time	tISU	6	–	–	ns
Input hold Time	tIH	2	–	–	ns
<b>Outputs: CMD, DAT (referenced to CLK)</b>					
Output delay time – Data Transfer Mode	tODLY	–	–	14	ns
Output hold time	tOH	2.5	–	–	ns
Total system capacitance (each line)	CL	–	–	40	pF

- a. Timing is based on  $CL \leq 40$ pF load on CMD and Data.
- b.  $\min(V_{ih}) = 0.7 \times VDDIO$  and  $\max(V_{il}) = 0.2 \times VDDIO$ .

### 14.3 JTAG Timing

**Table 25. JTAG Timing Characteristics**

Signal Name	Period	Output Maximum	Output Minimum	Setup	Hold
TCK	125 ns	–	–	–	–
TDI	–	–	–	20 ns	0 ns
TMS	–	–	–	20 ns	0 ns
TDO	–	100 ns	0 ns	–	–
JTAG_TRST	250 ns	–	–	–	–

## 15. Package Information

### 15.1 Package Thermal Characteristics

**Table 26. Package Thermal Characteristics<sup>a</sup>**

Characteristic	Value in Still Air
$\theta_{JA}$ (°C/W)	44.88
$\theta_{JB}$ (°C/W)	1.20
$\theta_{JC}$ (°C/W)	0.20
$\psi_{JT}$ (°C/W)	0.04
$\psi_{JB}$ (°C/W)	14.21
Maximum Junction Temperature $T_j$ (°C) <sup>b</sup>	125
Maximum Power Dissipation (W)	1.2

a. No heat sink,  $T_A = 70^\circ\text{C}$ . This is an estimate based on a 4-layer PCB that conforms to EIA/JESD51-7 (101.6 mm x 114.3 mm x 1.6 mm) and  $P = 1.2\text{W}$  continuous dissipation.

b. Absolute junction temperature limits maintained through active thermal monitoring and dynamic Tx duty cycle limiting.

#### 15.1.1 Junction Temperature Estimation and PSI Versus $\theta_{JC}$

Package thermal characterization parameter PSI-JT ( $\psi_{JT}$ ) yields a better estimation of actual junction temperature ( $T_j$ ) versus using the junction-to-case thermal resistance parameter  $\theta_{JC}$  ( $\theta_{JC}$ ). The reason for this is  $\theta_{JC}$  assumes that all the power is dissipated through the top surface of the package case. In actual applications, some of the power is dissipated through the bottom and sides of the package.  $\psi_{JT}$  takes into account power dissipated through the top, bottom, and sides of the package. The equation for calculating the device junction temperature is as follows:

$$T_j = T_T + P \times \psi_{JT}$$

Where:

- $T_j$  = junction temperature at steady-state condition, °C
- $T_T$  = package case top center temperature at steady-state condition, °C
- $P$  = device power dissipation, Watts
- $\psi_{JT}$  = package thermal characteristics (no airflow), °C/W

## 16. Mechanical Information

Figure 20. 69-Ball WLBGA Mechanical Information

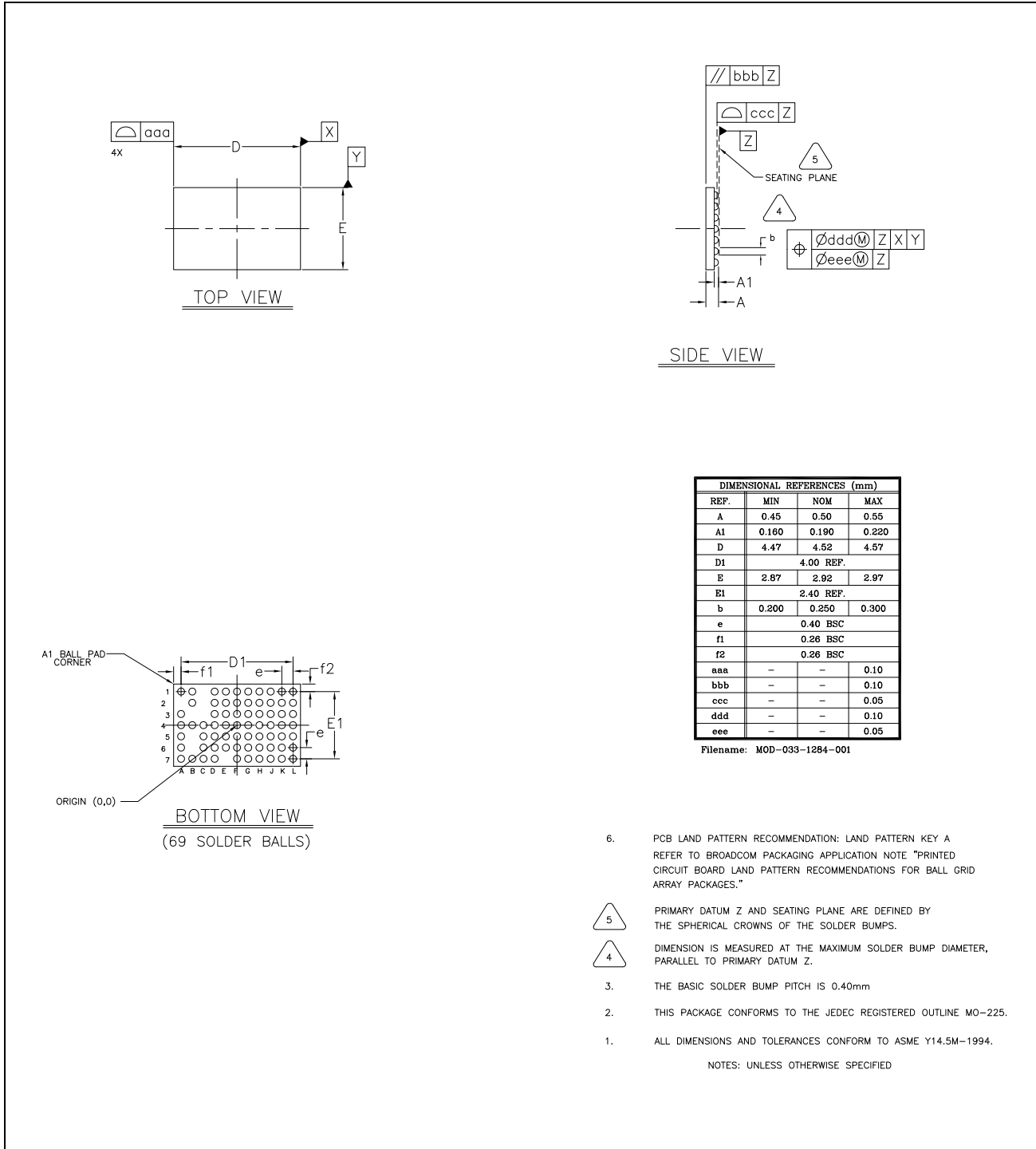

## 17. Ordering Information

Part Number	Package	Description	Operating Ambient Temperature
BCM43362KUBG	69-ball WLBGA halogen-free package (4.52 mm x 2.92 mm, 0.40 pitch)	Single-band IEEE 802.11b/g/n 2.4 GHz WLAN	-30°C to +85°C
<b>Note:</b> Add a "T" to the end of the part number to specify "Tape and Reel".			

## 18. References

The references in this section may be used in conjunction with this document.

Document (or Item) Name	Number	Source
<b>Cypress Items</b>		
CYW43362 reference board schematics	-	Cypress Representative

**Document History Page**

Document Title: CYW43362 Single-Chip IEEE 802.11™ b/g/n MAC/Baseband/Radio				
Document Number: 002-14779				
Revision	ECN	Orig. of Change	Submission Date	Description of Change
**	–	–	07/15/2010	43362-DS100-R Initial release
*A	–	–	02/17/2011	43362-DS101-R <b>Updated:</b> • LPO clock to LPO sleep clock throughout the document. • Figure3: “Power Topology,” on page 15. • “TCXO” on page 20. • Table2: “Crystal Oscillator and External Clock Requirements and Performance,” on page 21. • “External 32.768 kHz Low-Power Oscillator” on page 22. • Table3: “External 32.768 kHz Low-Power Oscillator Specifications,” on page 22. • Table8: “WLBGA Signal Descriptions,” on page 49. • Table9: “BCM43362 During Reset and After Reset or During Sleep,” on page 55. • Table12: “Environmental Ratings,” on page 59. • Table13: “ESD Specifications,” on page 59. • Table14: “Recommended Operating Conditions and DC Characteristics,” on page 60. • Table16: “WLAN 2.4 GHz Receiver Performance Specifications,” on page 62. • Table17: “WLAN 2.4 GHz Transmitter Performance Specifications,” on page 65. • Table18: “General Spurious Emissions Specifications,” on page 67. • Table19: “Core Buck Regulator,” on page 68. • Table20: “3.3V LDO (LDO3P3),” on page 71. • Table21: “CLDO,” on page 72. • Table22: “LNLDO1,” on page 73.
*B	–	–	03/28/2011	43362-DS102-R <b>Updated:</b> • Table11: “Absolute Maximum Ratings,” on page 62. • Table14: “Recommended Operating Conditions and DC Characteristics,” on page 64. • Table19: “Core Buck Regulator,” on page 73. • Table20: “3.3V LDO (LDO3P3),” on page 76.
*C	–	–	09/01/2011	43362-DS103-R <b>Updated:</b> • Changed maximum battery voltage range from 5.5V to 4.8V. • “Low-Power Shutdown” on page 20. • Table8: “WLBGA Signal Descriptions,” on page 53. • Table13: “ESD Specifications,” on page 63. • Table16: “WLAN 2.4 GHz Receiver Performance Specifications,” on page 67. • Table17: “WLAN 2.4 GHz Transmitter Performance Specifications,” on page 70. • Table18: “General Spurious Emissions Specifications,” on page 72. • Table19: “Core Buck Regulator,” on page 73. • Table20: “3.3V LDO (LDO3P3),” on page 76. • Table23: “System Power Consumption,” on page 79.
*D	–	–	02/17/2012	43362-DS104-R <b>Updated:</b> • Table23: “System Power Consumption,” on page 79 <b>Deleted:</b> • Support for Short GI mode in Tx and Rx
*E	–	–	04/07/2014	43362-DS105-R <b>Updated:</b> • IEEE 802.15.2 support for Zigbee and BT Smart on page 1. • Coexistence Interfaces for Zigbee and BT Smart on page 11. <b>Deleted:</b> • CCXv(2, 3, 4, 5) Proprietary Protocols on page 11.
*F	–	–	02/13/2015	43362-DS106-R <b>Updated:</b> • Removed “Preliminary” from the document type.
*G	5444083	UTSV	09/30/2016	Migrated to Cypress template format Added Cypress part numbering scheme
*H	5675324	UTSV	03/30/2017	Updated with Cypress new logo SPI/gSPI related sections are removed from this document.

## Sales, Solutions, and Legal Information

### Worldwide Sales and Design Support

Cypress maintains a worldwide network of offices, solution centers, manufacturer's representatives, and distributors. To find the office closest to you, visit us at [Cypress Locations](#).

#### Products

ARM® Cortex® Microcontrollers	<a href="http://cypress.com/arm">cypress.com/arm</a>
Automotive	<a href="http://cypress.com/automotive">cypress.com/automotive</a>
Clocks & Buffers	<a href="http://cypress.com/clocks">cypress.com/clocks</a>
Interface	<a href="http://cypress.com/interface">cypress.com/interface</a>
Internet of Things	<a href="http://cypress.com/iot">cypress.com/iot</a>
Lighting & Power Control	<a href="http://cypress.com/powerpsoc">cypress.com/powerpsoc</a>
Memory	<a href="http://cypress.com/memory">cypress.com/memory</a>
PSoC	<a href="http://cypress.com/psoc">cypress.com/psoc</a>
Touch Sensing	<a href="http://cypress.com/touch">cypress.com/touch</a>
USB Controllers	<a href="http://cypress.com/usb">cypress.com/usb</a>
Wireless/RF	<a href="http://cypress.com/wireless">cypress.com/wireless</a>

#### PSoC® Solutions

[PSoC 1](#) | [PSoC 3](#) | [PSoC 4](#) | [PSoC 5LP](#)

#### Cypress Developer Community

[Forums](#) | [WICED IoT Forum](#) | [Projects](#) | [Video](#) | [Blogs](#) | [Training Components](#)

#### Technical Support

[cypress.com/support](http://cypress.com/support)

---



© Cypress Semiconductor Corporation, 2010-2017. This document is the property of Cypress Semiconductor Corporation and its subsidiaries, including Spansion LLC ("Cypress"). This document, including any software or firmware included or referenced in this document ("Software"), is owned by Cypress under the intellectual property laws and treaties of the United States and other countries worldwide. Cypress reserves all rights under such laws and treaties and does not, except as specifically stated in this paragraph, grant any license under its patents, copyrights, trademarks, or other intellectual property rights. If the Software is not accompanied by a license agreement and you do not otherwise have a written agreement with Cypress governing the use of the Software, then Cypress hereby grants you a personal, non-exclusive, nontransferable license (without the right to sublicense) (1) under its copyright rights in the Software (a) for Software provided in source code form, to modify and reproduce the Software solely for use with Cypress hardware products, only internally within your organization, and (b) to distribute the Software in binary code form externally to end users (either directly or indirectly through resellers and distributors), solely for use on Cypress hardware product units, and (2) under those claims of Cypress's patents that are infringed by the Software (as provided by Cypress, unmodified) to make, use, distribute, and import the Software solely for use with Cypress hardware products. Any other use, reproduction, modification, translation, or compilation of the Software is prohibited.

TO THE EXTENT PERMITTED BY APPLICABLE LAW, CYPRESS MAKES NO WARRANTY OF ANY KIND, EXPRESS OR IMPLIED, WITH REGARD TO THIS DOCUMENT OR ANY SOFTWARE OR ACCOMPANYING HARDWARE, INCLUDING, BUT NOT LIMITED TO, THE IMPLIED WARRANTIES OF MERCHANTABILITY AND FITNESS FOR A PARTICULAR PURPOSE. To the extent permitted by applicable law, Cypress reserves the right to make changes to this document without further notice. Cypress does not assume any liability arising out of the application or use of any product or circuit described in this document. Any information provided in this document, including any sample design information or programming code, is provided only for reference purposes. It is the responsibility of the user of this document to properly design, program, and test the functionality and safety of any application made of this information and any resulting product. Cypress products are not designed, intended, or authorized for use as critical components in systems designed or intended for the operation of weapons, weapons systems, nuclear installations, life-support devices or systems, other medical devices or systems (including resuscitation equipment and surgical implants), pollution control or hazardous substances management, or other uses where the failure of the device or system could cause personal injury, death, or property damage ("Unintended Uses"). A critical component is any component of a device or system whose failure to perform can be reasonably expected to cause the failure of the device or system, or to affect its safety or effectiveness. Cypress is not liable, in whole or in part, and you shall and hereby do release Cypress from any claim, damage, or other liability arising from or related to all Unintended Uses of Cypress products. You shall indemnify and hold Cypress harmless from and against all claims, costs, damages, and other liabilities, including claims for personal injury or death, arising from or related to any Unintended Uses of Cypress products.

Cypress, the Cypress logo, Spansion, the Spansion logo, and combinations thereof, WICED, PSoC, CapSense, EZ-USB, F-RAM, and Traveo are trademarks or registered trademarks of Cypress in the United States and other countries. For a more complete list of Cypress trademarks, visit [cypress.com](http://cypress.com). Other names and brands may be claimed as property of their respective owners.

## Looking for pricing, stock, or lifecycle information?

Click below to explore more details on WIN SOURCE:

-  [View BCM43362KUBG on WIN SOURCE](#)
-  [Cypress Semiconductor Corp Information](#)

## Optimize Your Supply Chain with WIN SOURCE Solutions

-  Global Sourcing Solution
-  Obsolete Management
-  Cost Control Management
-  Shortage Management
-  Alternative Solution
-  Excess Inventory Management