



**THE DATASHEET OF  
MM908E625ACPEK**



# Integrated Quad Half H-Bridge with Power Supply, Embedded MCU, and LIN Serial Communication

The 908E625 is an integrated single package solution including a high performance HC08 microcontroller with a SMARTMOS analog control IC. The HC08 includes flash memory, a timer, enhanced serial communications interface (ESCI), an analog-to-digital converter (ADC), internal serial peripheral interface (SPI), and an internal clock generator (ICG) module. The analog control die provides fully protected H-Bridge/high side outputs, voltage regulator, autonomous watchdog with cyclic wake-up, and local interconnect network (LIN) physical layer.

The single package solution, together with LIN, provides optimal application performance adjustments and space saving PCB design. It is well-suited for the control of automotive mirror, door lock, and light-leveling applications.

## Features

- High-performance M68HC908EY16 core
- 16 KB of on-chip flash memory & 512 B of RAM
- Internal clock generation module
- Two 16-bit, two-channel timers
- 10-bit ADC
- LIN physical layer
- Autonomous watchdog with cyclic wake-up
- Three two-pin Hall effect sensor input ports
- One analog input with switchable current source
- Four low  $R_{DS(ON)}$  half-bridge outputs
- One low  $R_{DS(ON)}$  high side output
- 13 micro controller I/Os

908E625

H-BRIDGE POWER SUPPLY WITH EMBEDDED MCU AND LIN

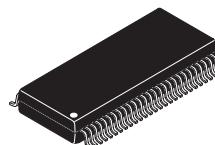

EK SUFFIX  
98ARL10519D  
54-PIN SOICW-EP

## ORDERING INFORMATION

Device (Add an R2 suffix for Tape and reel orders)	Temperature Range (T <sub>A</sub> )	Package
MM908E625ACPEK	-40 to 85 °C	54 SOICW EP

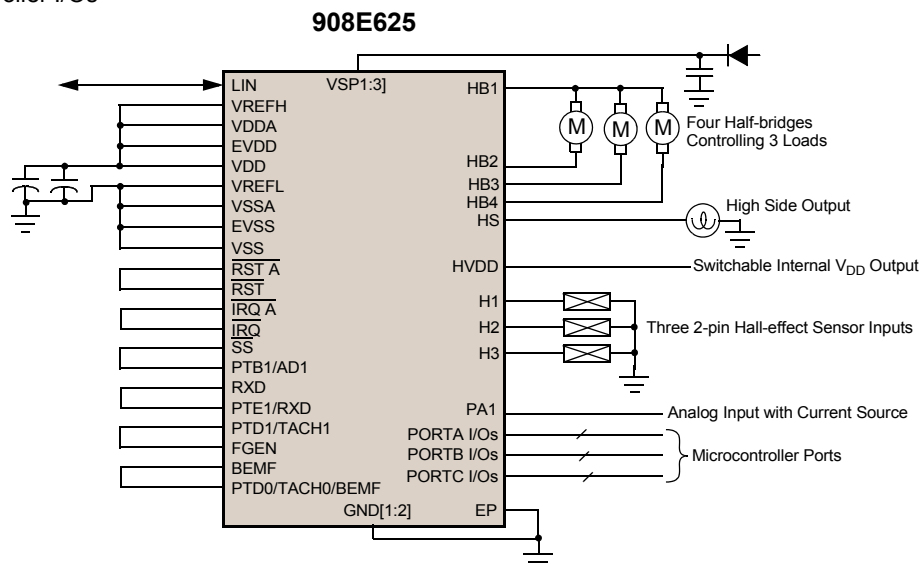

Figure 1. 908E625 Simplified Application Diagram

\* This document contains information on a new product. Specifications and information herein are subject to change without notice.

### INTERNAL BLOCK DIAGRAM

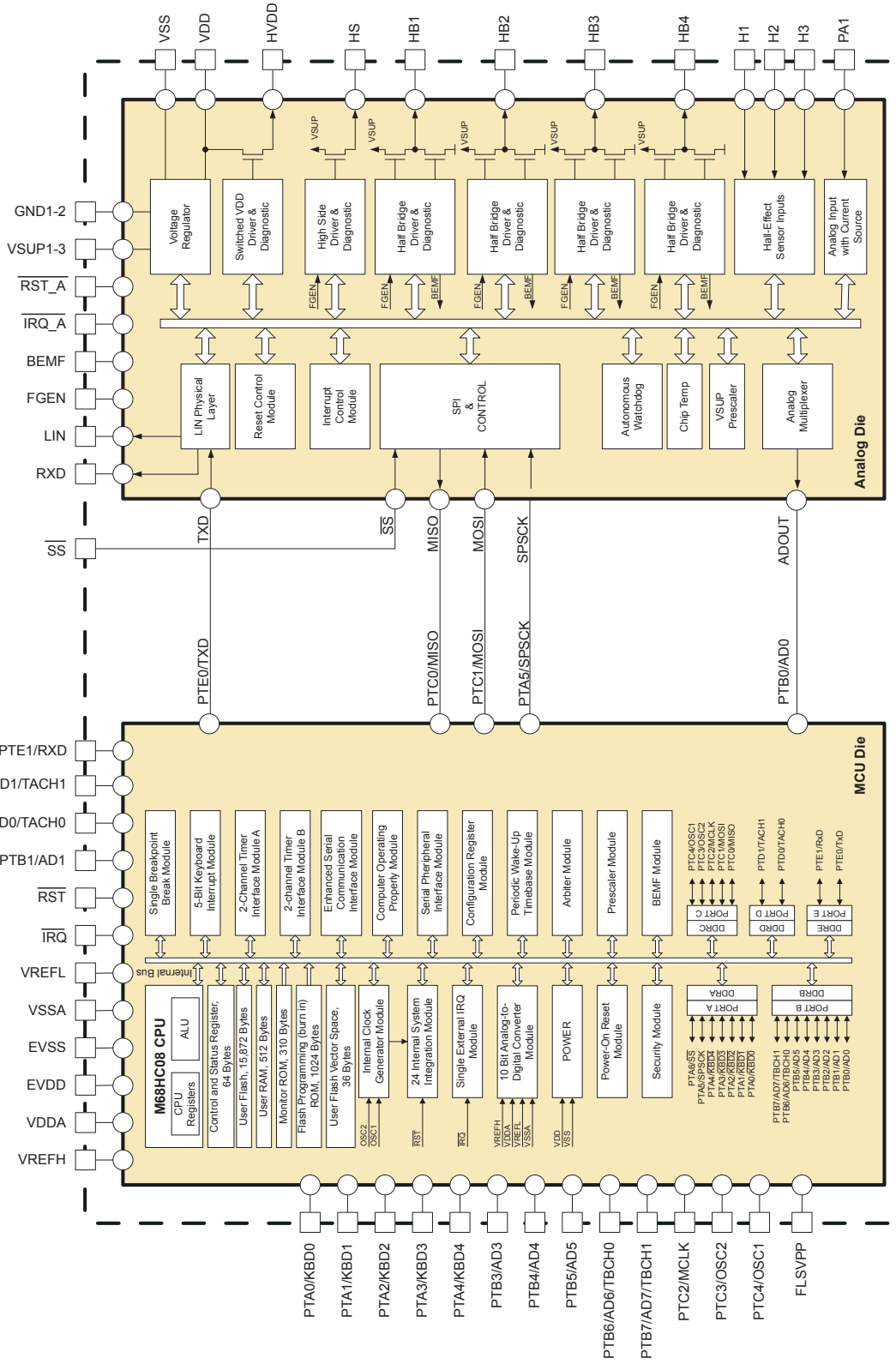
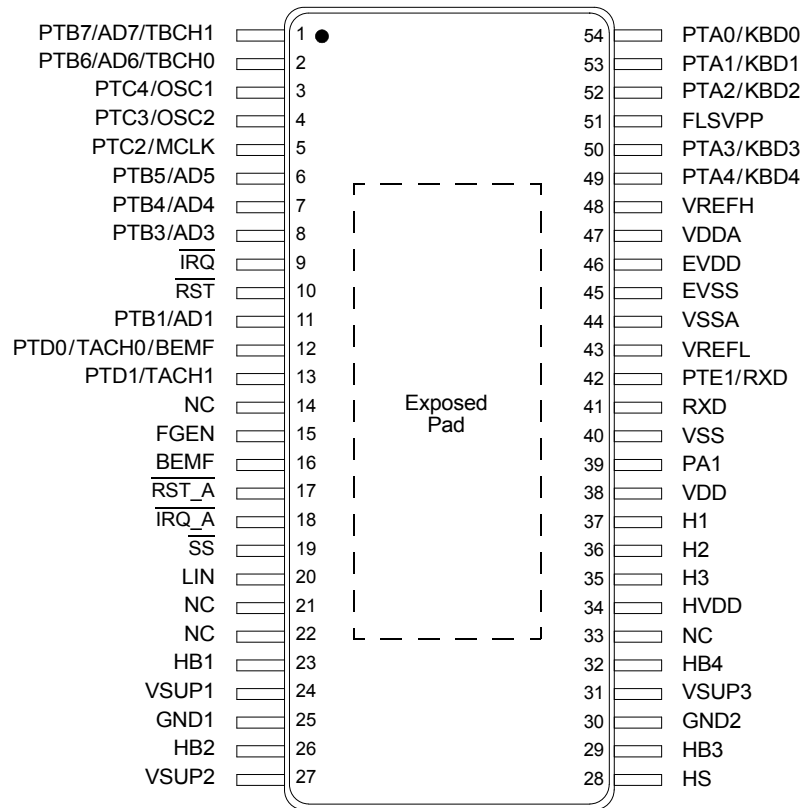

Figure 2. 908E625 Simplified Internal Block Diagram

## PIN CONNECTIONS



**Figure 3. 908E625 Pin Connections (Transparent Package Top View)**

**Table 1. 908E625 Pin Definitions**

A functional description of each pin can be found in the Functional Pin Description section beginning on [page 14](#).

Pin Function	Pin	Pin Name	Formal Name	Definition
MCU	1 2 6 7 8 11	PTB7/AD7/TBCH1 PTB6/AD6/TBCH0 PTB5/AD5 PTB4/AD4 PTB3/AD3 PTB1/AD1	Port B I/Os	These pins are special function, bi-directional I/O port pins that are shared with other functional modules in the MCU.
MCU	3 4 5	PTC4/OSC1 PTC3/OSC2 PTC2/MCLK	Port C I/Os	These pins are special function, bi-directional I/O port pins that are shared with other functional modules in the MCU.
MCU	9	$\overline{\text{IRQ}}$	External Interrupt Input	This pin is an asynchronous external interrupt input pin.
MCU	10	RST	External Reset	This pin is bi-directional, allowing a reset of the entire system. It is driven low when any internal reset source is asserted.
MCU	12 13	PTD0/TACH0/BEMF PTD1/TACH1	Port D I/Os	These pins are special function, bi-directional I/O port pins that are shared with other functional modules in the MCU.
–	14, 21, 22, 33	NC	No Connect	Not connected.

**Table 1. 908E625 Pin Definitions (continued)**

A functional description of each pin can be found in the Functional Pin Description section beginning on [page 14](#).

Pin Function	Pin	Pin Name	Formal Name	Definition
MCU	42	PTE1/RXD	Port E I/O	This pin is a special function, bi-directional I/O port pin that can be shared with other functional modules in the MCU.
MCU	43 48	VREFL VREFH	ADC References	These pins are the reference voltage pins for the analog-to-digital converter (ADC).
MCU	44 47	VSSA VDDA	ADC Supply pins	These pins are the power supply pins for the analog-to-digital converter.
MCU	45 46	EVSS EVDD	MCU Power Supply Pins	These pins are the ground and power supply pins, respectively. The MCU operates from a single power supply.
MCU	49 50 52 53 54	PTA4/KBD4 PTA3/KBD3 PTA2/KBD2 PTA1/KBD1 PTA0/KBD0	Port A I/Os	These pins are special function, bi-directional I/O port pins that are shared with other functional modules in the MCU.
MCU	51	FLSVPP	Test Pin	For test purposes only. Do not connect in the application.
Analog	15	FGEN	Current Limitation Frequency Input	This is the input pin for the half-bridge current limitation and the high side inrush current limiter PWM frequency.
Analog	16	BEMF	Back Electromagnetic Force Output	This pin gives the user information about back electromagnetic force (BEMF).
Analog	17	RST_A	Internal Reset	This pin is the bi-directional reset pin of the analog die.
Analog	18	IRQ_A	Internal Interrupt Output	This pin is the interrupt output pin of the analog die indicating errors or wake-up events.
Analog	19	SS	Slave Select	This pin is the SPI slave select pin for the analog chip.
Analog	20	LIN	LIN Bus	This pin represents the single wire bus transmitter and receiver.
Analog	23 26 29 32	HB1 HB2 HB3 HB4	Half-bridge Outputs	This device includes power MOSFETs configured as four half-bridge driver outputs. These outputs may be configured for step motor drivers, DC motor drivers, or as high side and low side switches.
Analog	24 27 31	VSUP1 VSUP2 VSUP3	Power Supply Pins	These pins are device power supply pins.
Analog	25 30	GND1 GND2	Power Ground Pins	These pins are device power ground connections.
Analog	28	HS	High-Side Output	This output pin is a low $R_{DS(ON)}$ high side switch.
Analog	34	HVDD	Switchable $V_{DD}$ Output	This pin is a switchable $V_{DD}$ output for driving resistive loads requiring a regulated 5.0 V supply; e.g., 3-pin Hall-effect sensors.
Analog	35 36 37	H3 H2 H1	Hall-effect Sensor Inputs	These pins provide inputs for Hall-effect sensors and switches.
Analog	38	VDD	Voltage Regulator Output	The +5.0 V voltage regulator output pin is intended to supply the embedded microcontroller.
Analog	39	PA1	Analog Input	This pin is an analog input port with selectable source values.
Analog	40	VSS	Voltage Regulator Ground	Ground pin for the connection of all non-power ground connections (microcontroller and sensors).
Analog	41	RXD	LIN Transceiver Output	This pin is the output of LIN transceiver.
–	EP	Exposed Pad	Exposed Pad	The exposed pad pin on the bottom side of the package conducts heat from the chip to the PCB board.

## ELECTRICAL CHARACTERISTICS

### MAXIMUM RATINGS

**Table 2. Maximum Ratings**

All voltages are with respect to ground unless otherwise noted. Exceeding these ratings may cause a malfunction or permanent damage to the device.

Ratings	Symbol	Value	Unit
<b>ELECTRICAL RATINGS</b>			
Supply Voltage			V
Analog Chip Supply Voltage under Normal Operation, Steady State	$V_{SUP(SS)}$	-0.3 to 28	
Analog Chip Supply Voltage under Transient Conditions <sup>(1)</sup>	$V_{SUP(PK)}$	-0.3 to 40	
Microcontroller Chip Supply Voltage	$V_{DD}$	-0.3 to 6.0	
Input Pin Voltage			V
Analog Chip	$V_{IN(ANALOG)}$	-0.3 to 5.5	
Microcontroller Chip	$V_{IN(MCU)}$	$V_{SS}-0.3$ to $V_{DD}+0.3$	
Maximum Microcontroller Current per Pin			mA
All Pins Except VDD, VSS, PTA0:PTA6, PTC0:PTC1	$I_{PIN(1)}$	±15	
Pins PTA0:PTA6, PTC0:PTC1	$I_{PIN(2)}$	±25	
Maximum Microcontroller $V_{SS}$ Output Current	$I_{MVSS}$	100	mA
Maximum Microcontroller $V_{DD}$ Input Current	$I_{MVDD}$	100	mA
LIN Supply Voltage			V
Normal Operation (Steady-State)	$V_{BUS(SS)}$	-18 to 28	
Transient Conditions <sup>(1)</sup>	$V_{BUS(DYNAMIC)}$	40	
ESD Voltage			V
Human Body Model (HBM) <sup>(2)</sup>	$V_{ESD}$	±3000	
Machine Model (MM) <sup>(3)</sup>		±150	
Charge Device Model (CDM) <sup>(4)</sup>		±500	
<b>THERMAL RATINGS</b>			
Storage Temperature	$T_{STG}$	-40 to 150	°C
Ambient Operating Temperature	$T_A$	-40 to 85	°C
Operating Case Temperature <sup>(5)</sup>	$T_C$	-40 to 85	°C
Operating Junction Temperature <sup>(6)</sup>	$T_J$	-40 to 125	°C
Peak Package Reflow Temperature During Reflow <sup>(7)(8)</sup>	$T_{PPRT}$	Note 8	°C

**Notes**

- Transient capability for pulses with a time of  $t < 0.5$  sec.
- ESD voltage testing is performed in accordance with the Human Body Model ( $C_{ZAP} = 100$  pF,  $R_{ZAP} = 1500 \Omega$ )
- ESD voltage testing is performed in accordance with the Machine Model ( $C_{ZAP} = 200$  pF,  $R_{ZAP} = 0 \Omega$ )
- ESD voltage testing is performed in accordance with Charge Device Model, robotic ( $C_{ZAP} = 4.0$  pF).
- The limiting factor is junction temperature, taking into account the power dissipation, thermal resistance, and heat sinking.
- The temperature of analog and MCU die is strongly linked via the package, but can differ in dynamic load conditions, usually because of higher power dissipation on the analog die. The analog die temperature must not exceed 150 °C under these conditions.
- Pin soldering temperature is for 10 seconds maximum duration. Not designed for immersion soldering. Exceeding these limits may cause malfunction or permanent damage to the device.
- Freescale's Package Reflow capability meets Pb-free requirements for JEDEC standard J-STD-020C. For Peak Package Reflow Temperature and Moisture Sensitivity Levels (MSL), Go to [www.freescale.com](http://www.freescale.com), search by part number [e.g. remove prefixes/suffixes and enter the core ID to view all orderable parts. (i.e. MC33xxx enter 33xxx)], and review parameters.

### STATIC ELECTRICAL CHARACTERISTICS

**Table 3. Static Electrical Characteristics**

All characteristics are for the analog chip only. Refer to the 68HC908EY16 specification for characteristics of the microcontroller chip. Characteristics noted under conditions  $9.0\text{ V} \leq V_{\text{SUP}} \leq 16\text{ V}$ ,  $-40\text{ }^\circ\text{C} \leq T_{\text{J}} \leq 125\text{ }^\circ\text{C}$ , unless otherwise noted. Typical values noted reflect the approximate parameter mean at  $T_{\text{A}} = 25\text{ }^\circ\text{C}$  under nominal conditions, unless otherwise noted.

Characteristic	Symbol	Min	Typ	Max	Unit
<b>SUPPLY VOLTAGE</b>					
Nominal Operating Voltage	$V_{\text{SUP}}$	8.0	–	18	V
<b>SUPPLY CURRENT</b>					
Normal Mode $V_{\text{SUP}} = 12\text{ V}$ , Power Die ON (PSON=1), MCU Operating Using Internal Oscillator at 32 MHz (8.0 MHz Bus Frequency), SPI, ESCI, ADC Enabled	$I_{\text{RUN}}$	–	20	–	mA
STOP Mode <sup>(9)</sup> $V_{\text{SUP}} = 12\text{ V}$ , Cyclic Wake-up Disabled	$I_{\text{STOP}}$	–	–	60	$\mu\text{A}$
<b>DIGITAL INTERFACE RATINGS (ANALOG DIE)</b>					
Output Pins $\overline{\text{RST\_A}}$ , $\overline{\text{IRQ\_A}}$ Low State Output Voltage ( $I_{\text{OUT}} = -1.5\text{ mA}$ ) High State Output Voltage ( $I_{\text{OUT}} = 1.0\text{ }\mu\text{A}$ )	$V_{\text{OL}}$ $V_{\text{OH}}$	– 3.85	– –	0.4 –	V
Output Pins BEMF, RXD Low State Output Voltage ( $I_{\text{OUT}} = -1.5\text{ mA}$ ) High State Output Voltage ( $I_{\text{OUT}} = 1.5\text{ mA}$ )	$V_{\text{OL}}$ $V_{\text{OH}}$	– 3.85	– –	0.4 –	V
Output Pin RXD–Capacitance <sup>(10)</sup>	$C_{\text{IN}}$	–	4.0	–	pF
Input Pins $\overline{\text{RST\_A}}$ , FGEN, $\overline{\text{SS}}$ Input Logic Low Voltage Input Logic High Voltage	$V_{\text{IL}}$ $V_{\text{IH}}$	– 3.5	– –	1.5 –	V
Input Pins $\overline{\text{RST\_A}}$ , FGEN, $\overline{\text{SS}}$ –Capacitance <sup>(10)</sup>	$C_{\text{IN}}$	–	4.0	–	pF
Pins $\overline{\text{RST\_A}}$ , $\overline{\text{IRQ\_A}}$ –Pull-up Resistor	$R_{\text{PULLUP1}}$	–	10	–	$\text{k}\Omega$
Pin $\overline{\text{SS}}$ –Pull-up Resistor	$R_{\text{PULLUP2}}$	–	60	–	$\text{k}\Omega$
Pins FGEN, MOSI, SPCK–Pull-down Resistor	$R_{\text{PULLDOWN}}$	–	60	–	$\text{k}\Omega$
Pin TXD–Pull-up Current Source	$I_{\text{PULLUP}}$	–	35	–	$\mu\text{A}$

**Notes**

9. STOP mode current will increase if  $V_{\text{SUP}}$  exceeds 15 V.
10. This parameter is guaranteed by process monitoring but is not production tested.

**Table 3. Static Electrical Characteristics (continued)**

All characteristics are for the analog chip only. Refer to the 68HC908EY16 specification for characteristics of the microcontroller chip. Characteristics noted under conditions  $9.0\text{ V} \leq V_{\text{SUP}} \leq 16\text{ V}$ ,  $-40\text{ }^\circ\text{C} \leq T_J \leq 125\text{ }^\circ\text{C}$ , unless otherwise noted. Typical values noted reflect the approximate parameter mean at  $T_A = 25\text{ }^\circ\text{C}$  under nominal conditions, unless otherwise noted.

Characteristic	Symbol	Min	Typ	Max	Unit
<b>SYSTEM RESETS AND INTERRUPTS</b>					
High Voltage Reset					V
Threshold	$V_{\text{HVRON}}$	27	30	33	
Hysteresis	$V_{\text{HVRH}}$	–	1.5	–	
Low Voltage Reset					V
Threshold	$V_{\text{LVRON}}$	3.6	4.0	4.5	
Hysteresis	$V_{\text{LVRH}}$	–	100	–	mV
High Voltage Interrupt					V
Threshold	$V_{\text{HVION}}$	17.5	21	23	
Hysteresis	$V_{\text{HVIH}}$	–	1.0	–	
Low Voltage Interrupt					V
Threshold	$V_{\text{LVION}}$	6.5	–	8.0	
Hysteresis	$V_{\text{LVIH}}$	–	0.4	–	
High Temperature Reset <sup>(11)</sup>					$^\circ\text{C}$
Threshold	$T_{\text{RON}}$	–	170	–	
Hysteresis	$T_{\text{RH}}$	5.0	–	–	
High Temperature Interrupt <sup>(12)</sup>					$^\circ\text{C}$
Threshold	$T_{\text{ION}}$	–	160	–	
Hysteresis	$T_{\text{IH}}$	5.0	–	–	
<b>VOLTAGE REGULATOR</b>					
Normal Mode Output Voltage $I_{\text{OUT}} = 60\text{ mA}$ , $6.0\text{ V} < V_{\text{SUP}} < 18\text{ V}$	$V_{\text{DDRUN}}$	4.75	5.0	5.25	V
Load Regulation $I_{\text{OUT}} = 80\text{ mA}$ , $V_{\text{SUP}} = 9.0\text{ V}$ , $T_J = 125\text{ }^\circ\text{C}$	$V_{\text{LR}}$	–	–	100	mV
Stop Mode Output Voltage (Maximum Output Current 100 $\mu\text{A}$ )	$V_{\text{DDSTOP}}$	4.45	4.7	5.0	V
<b>LIN PHYSICAL LAYER</b>					
Output Low Level TXD LOW, 500 $\Omega$ Pull-up to $V_{\text{SUP}}$	$V_{\text{LIN-LOW}}$	–	–	1.4	V
Output High Level TXD HIGH, $I_{\text{OUT}} = 1.0\text{ }\mu\text{A}$	$V_{\text{LIN-HIGH}}$	$V_{\text{SUP}} - 1.0$	–	–	V
Pullup Resistor to $V_{\text{SUP}}$	$R_{\text{SLAVE}}$	20	30	60	$\text{k}\Omega$
Leakage Current to GND Recessive State ( $-0.5\text{ V} < V_{\text{LIN}} < V_{\text{SUP}}$ )	$I_{\text{BUS\_PAS\_rec}}$	0.0	–	20	$\mu\text{A}$
Leakage Current to GND ( $V_{\text{SUP}}$ Disconnected) Including Internal Pull-up Resistor, $V_{\text{LIN}} @ -18\text{ V}$ Including Internal Pull-up Resistor, $V_{\text{LIN}} @ +18\text{ V}$	$I_{\text{BUS\_NO\_GND}}$ $I_{\text{BUS}}$	– –	-600 25	– –	$\mu\text{A}$

**Notes**

- This parameter is guaranteed by process monitoring but is not production tested.
- High Temperature Interrupt (HTI) threshold is linked to High Temperature Reset (HTR) threshold ( $\text{HTR} = \text{HTI} + 10\text{ }^\circ\text{C}$ ).

**Table 3. Static Electrical Characteristics (continued)**

All characteristics are for the analog chip only. Refer to the 68HC908EY16 specification for characteristics of the microcontroller chip. Characteristics noted under conditions  $9.0\text{ V} \leq V_{\text{SUP}} \leq 16\text{ V}$ ,  $-40\text{ }^\circ\text{C} \leq T_J \leq 125\text{ }^\circ\text{C}$ , unless otherwise noted. Typical values noted reflect the approximate parameter mean at  $T_A = 25\text{ }^\circ\text{C}$  under nominal conditions, unless otherwise noted.

Characteristic	Symbol	Min	Typ	Max	Unit
LIN Receiver					V
Recessive	$V_{\text{IH}}$	$0.6 V_{\text{LIN}}$	–	$V_{\text{SUP}}$	
Dominant	$V_{\text{IL}}$	0.0	–	$0.4 V_{\text{LIN}}$	
Threshold	$V_{\text{ITH}}$	–	$V_{\text{SUP}}/2$	–	
Input Hysteresis	$V_{\text{IHY}}$	$0.01 V_{\text{SUP}}$	–	$0.1 V_{\text{SUP}}$	
LIN Wake-up Threshold	$V_{\text{WTH}}$	–	$V_{\text{SUP}}/2$	–	V

**HIGH SIDE OUTPUT (HS)**

Switch ON Resistance @ $T_J = 25\text{ }^\circ\text{C}$ with $I_{\text{LOAD}} = 1.0\text{ A}$	$R_{\text{DS(ON)HS}}$	–	600	700	m $\Omega$
High Side Over-current Shutdown	$I_{\text{HSOC}}$	3.9	–	7.0	A

**HALF-BRIDGE OUTPUTS (HB1:HB4)**

Switch ON Resistance @ $T_J = 25\text{ }^\circ\text{C}$ with $I_{\text{LOAD}} = 1.0\text{ A}$					m $\Omega$
High Side	$R_{\text{DS(ON)HB_HS}}$	–	425	500	
Low Side	$R_{\text{DS(ON)HB_LS}}$	–	400	500	
High Side Over-current Shutdown	$I_{\text{HBHSOC}}$	4.0	–	7.5	A
Low Side Over-current Shutdown	$I_{\text{HBSOC}}$	2.8	–	7.5	A
Low Side Current Limitation @ $T_J = 25\text{ }^\circ\text{C}$					mA
Current Limit 1 (CLS2 = 0, CLS1 = 1, CLS0 = 1)	$I_{\text{CL1}}$	–	55	–	
Current Limit 2 (CLS2 = 1, CLS1 = 0, CLS0 = 0)	$I_{\text{CL2}}$	210	260	315	
Current Limit 3 (CLS2 = 1, CLS1 = 0, CLS0 = 1)	$I_{\text{CL3}}$	300	370	440	
Current Limit 4 (CLS2 = 1, CLS1 = 1, CLS0 = 0)	$I_{\text{CL4}}$	450	550	650	
Current Limit 5 (CLS2 = 1, CLS1 = 1, CLS0 = 1)	$I_{\text{CL5}}$	600	740	880	
Half-bridge Output High Threshold for BEMF Detection	$V_{\text{BEMFH}}$	–	-30	0	V
Half-bridge Output Low Threshold for BEMF Detection	$V_{\text{BEMFL}}$	–	-60	-5.0	mV
Hysteresis for BEMF Detection	$V_{\text{BEMFHY}}$	–	30	–	mV
Low Side Current-to-Voltage Ratio ( $V_{\text{ADOUT}} [\text{V}]/I_{\text{HB}} [\text{A}]$ )					V/A
CSA = 1	$\text{RATIO}_H$	7.0	12.0	14.0	
CSA = 0	$\text{RATIO}_L$	1.0	2.0	3.0	

**SWITCHABLE  $V_{\text{DD}}$  OUTPUT (PH.D.)**

Over-current Shutdown Threshold	$I_{\text{HVDDOCT}}$	24	30	40	mA
---------------------------------	----------------------	----	----	----	----

**$V_{\text{SUP}}$  DOWN-SCALER**

Voltage Ratio ( $\text{RATIO}_{V_{\text{SUP}}} = V_{\text{SUP}}/V_{\text{ADOUT}}$ )	$\text{RATIO}_{V_{\text{SUP}}}$	4.8	5.1	5.35	–
---	---------------------------------	-----	-----	------	---

**INTERNAL DIE TEMPERATURE SENSOR**

Voltage/Temperature Slope	$S_{\text{TTOV}}$	–	19	–	mV/ $^\circ\text{C}$
Output Voltage @ $25\text{ }^\circ\text{C}$	$V_{\text{T25}}$	1.7	2.1	2.5	V

**HALL-EFFECT SENSOR INPUTS (H1:H3)**

Output Voltage					V
$V_{\text{SUP}} < 16.2\text{ V}$	$V_{\text{HALL1}}$	–	$V_{\text{SUP}} - 1.2$	–	
$V_{\text{SUP}} > 16.2\text{ V}$	$V_{\text{HALL2}}$	–	–	15	

**Table 3. Static Electrical Characteristics (continued)**

All characteristics are for the analog chip only. Refer to the 68HC908EY16 specification for characteristics of the microcontroller chip. Characteristics noted under conditions  $9.0\text{ V} \leq V_{\text{SUP}} \leq 16\text{ V}$ ,  $-40\text{ }^\circ\text{C} \leq T_{\text{J}} \leq 125\text{ }^\circ\text{C}$ , unless otherwise noted. Typical values noted reflect the approximate parameter mean at  $T_{\text{A}} = 25\text{ }^\circ\text{C}$  under nominal conditions, unless otherwise noted.

Characteristic	Symbol	Min	Typ	Max	Unit
Sense Current					mA
Threshold	$I_{\text{HSCT}}$	6.9	8.8	11	
Hysteresis	$I_{\text{HSCH}}$	–	0.88	–	
Output Current Limitation	$I_{\text{HL}}$	–	90	–	mA
Over-current Warning HP_OCF Flag Threshold]	$V_{\text{HPOCT}}$	–	3.0	–	V
Dropout Voltage @ $I_{\text{LOAD}} = 15\text{ mA}$	$V_{\text{HPDO}}$	–	0.5	–	V

**ANALOG INPUT (PA1)**

Current Source PA1 CSSEL1 = 1, CSSEL0 = 1	$I_{\text{CSPA1}}$	570	670	770	$\mu\text{A}$
Selectable Scaling Factor Current Source PA1 ( $I(N) = I_{\text{CSPA1}} * N$ )					%
CSSEL1 = 0, CSSEL0 = 0	$N_{\text{CSPA1-0}}$	8.5	10	11.5	
CSSEL1 = 0, CSSEL0 = 1	$N_{\text{CSPA1-1}}$	28.5	30	31.5	
CSSEL1 = 1, CSSEL0 = 0	$N_{\text{CSPA1-2}}$	58.5	60	61.5	

## DYNAMIC ELECTRICAL CHARACTERISTICS

**Table 4. Dynamic Electrical Characteristics**

All characteristics are for the analog chip only. Please refer to the specification for 68HC908EY16 for characteristics of the microcontroller chip. Characteristics noted under conditions  $9.0\text{ V} \leq V_{\text{SUP}} \leq 16\text{ V}$ ,  $-40\text{ }^\circ\text{C} \leq T_J \leq 125\text{ }^\circ\text{C}$ , unless otherwise noted. Typical values noted reflect the approximate parameter mean at  $T_A = 25\text{ }^\circ\text{C}$  under nominal conditions, unless otherwise noted.

Characteristic	Symbol	Min	Typ	Max	Unit
<b>LIN PHYSICAL LAYER</b>					
Propagation Delay <sup>(13), (14)</sup>					$\mu\text{s}$
TXD Low to LIN Low	$t_{\text{TXD-LIN-low}}$	–	–	6.0	
TXD High to LIN High	$t_{\text{TXD-LIN-high}}$	–	–	6.0	
LIN Low to RXD Low	$t_{\text{LIN-RXD-low}}$	–	4.0	8.0	
LIN High to RXD High	$t_{\text{LIN-RXD-high}}$	–	4.0	8.0	
TXD Symmetry	$t_{\text{TXD-SYM}}$	-2.0	–	2.0	
RXD Symmetry	$t_{\text{RXD-SYM}}$	-2.0	–	2.0	
Output Falling Edge Slew Rate <sup>(13), (15)</sup> 80% to 20%	$\text{SR}_F$	-1.0	-2.0	-3.0	$\text{V}/\mu\text{s}$
Output Rising Edge Slew Rate <sup>(13), (15)</sup> 20% to 80%, $R_{\text{BUS}} > 1.0\text{ k}\Omega$ , $C_{\text{BUS}} < 10\text{ nF}$	$\text{SR}_R$	1.0	2.0	3.0	$\text{V}/\mu\text{s}$
LIN Rise/Fall Slew Rate Symmetry <sup>(13), (15)</sup>	$\text{SR}_S$	-2.0	–	2.0	$\mu\text{s}$
<b>HALL-EFFECT SENSOR INPUTS (H1:H3)</b>					
Propagation Delay	$t_{\text{HPPD}}$	–	1.0	–	$\mu\text{s}$
<b>AUTONOMOUS WATCHDOG (AWD)</b>					
AWD Oscillator Period	$t_{\text{OSC}}$	–	40	–	$\mu\text{s}$
AWD Period Low = 512 $t_{\text{OSC}}$	$t_{\text{AWDPH}}$				ms
$T_J < 25\text{ }^\circ\text{C}$		16	27	34	
$T_J \geq 25\text{ }^\circ\text{C}$		16	22	28	
AWD Period High = 256 $t_{\text{OSC}}$	$t_{\text{AWDPL}}$				ms
$T_J < 25\text{ }^\circ\text{C}$		8.0	13.5	17	
$T_J \geq 25\text{ }^\circ\text{C}$		8.0	11	14	
AWD Cyclic Wake-up On Time	$t_{\text{AWDHPO}}N$	–	90	–	$\mu\text{s}$

**Notes**

- 13. All LIN characteristics are for initial LIN slew rate selection (20 kBaud) (SRS0:SRS1= 00).
- 14. See [Figure 2](#).
- 15. See [Figure 3](#).

### MICROCONTROLLER PARAMETRICS

**Table 5. Microcontroller Description**

For a detailed microcontroller description, refer to the MC68HC908EY16 data sheet.

Module	Description
Core	High Performance HC08 Core with a Maximum Internal Bus Frequency of 8.0 MHz
Timer	Two 16-Bit Timers with Two Channels (TIM A and TIM B)
Flash	16 K Bytes
RAM	512 Bytes
ADC	10-Bit Analog-to-Digital Converter
SPI	SPI Module
ESCI	Standard Serial Communication Interface (SCI) Module Bit-Time Measurement Arbitration Prescaler with Fine Baud Rate Adjustment
ICG	Internal Clock Generation Module (25% Accuracy with Trim Capability to 2%)
BEMF Counter	Special Counter for SMARTMOS™ BEMF Output

### TIMING DIAGRAMS

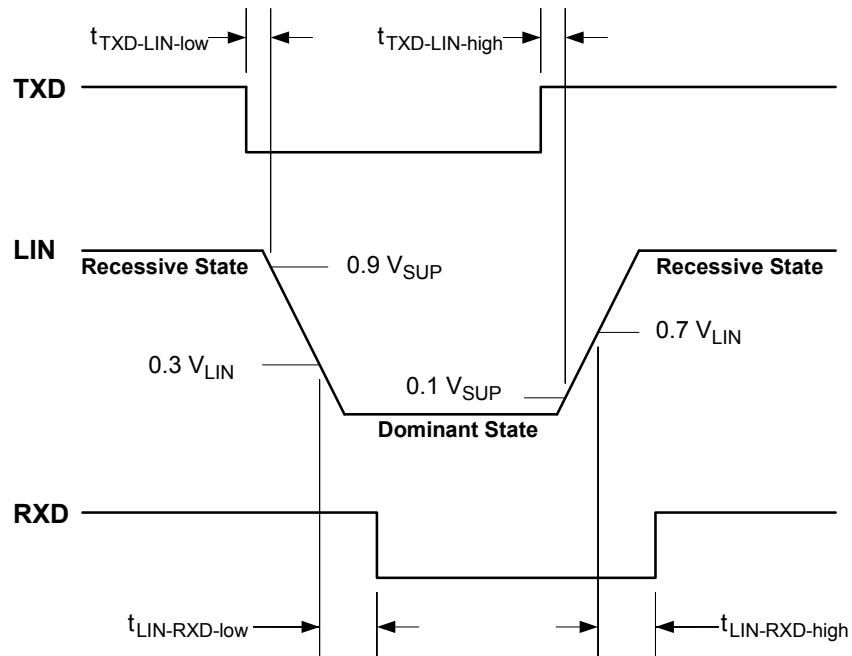
**Figure 4. LIN Timing Description**

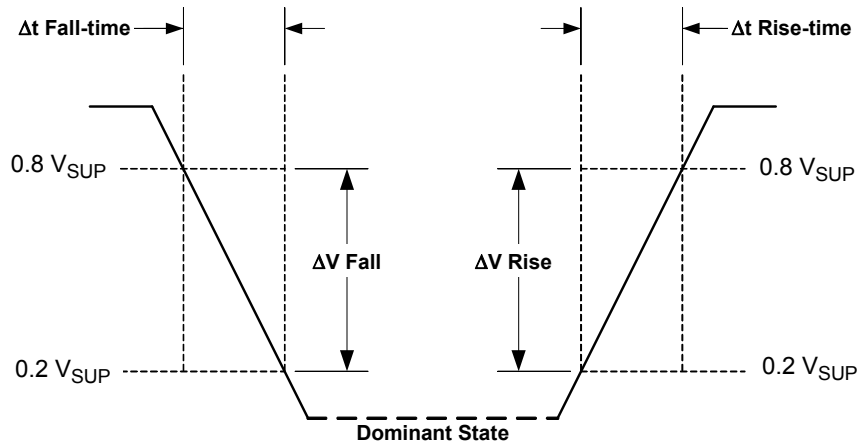

$$SR_F = \frac{\Delta V \text{ Fall}}{\Delta t \text{ Fall-time}}$$

$$SR_R = \frac{\Delta V \text{ Rise}}{\Delta t \text{ Rise-time}}$$

Figure 5. LIN Slew Rate Description

**ELECTRICAL PERFORMANCE CURVES**

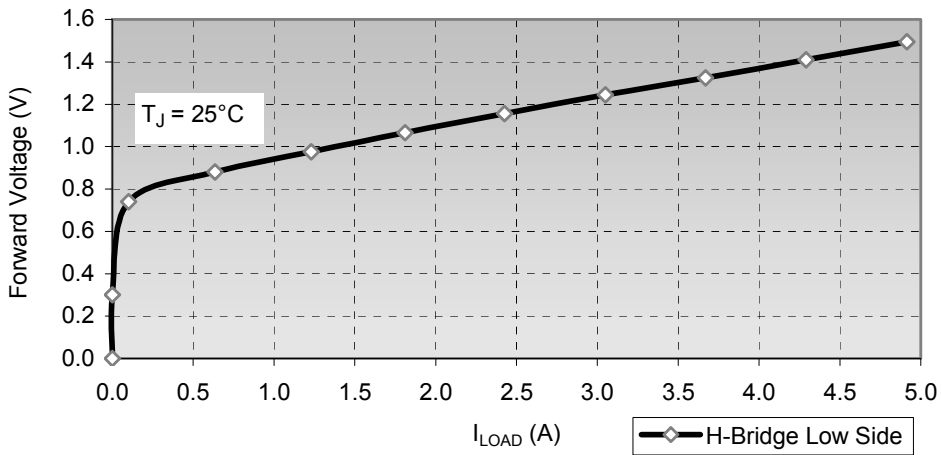

Figure 6. Free Wheel Diode Forward Voltage vs. I\_LOAD

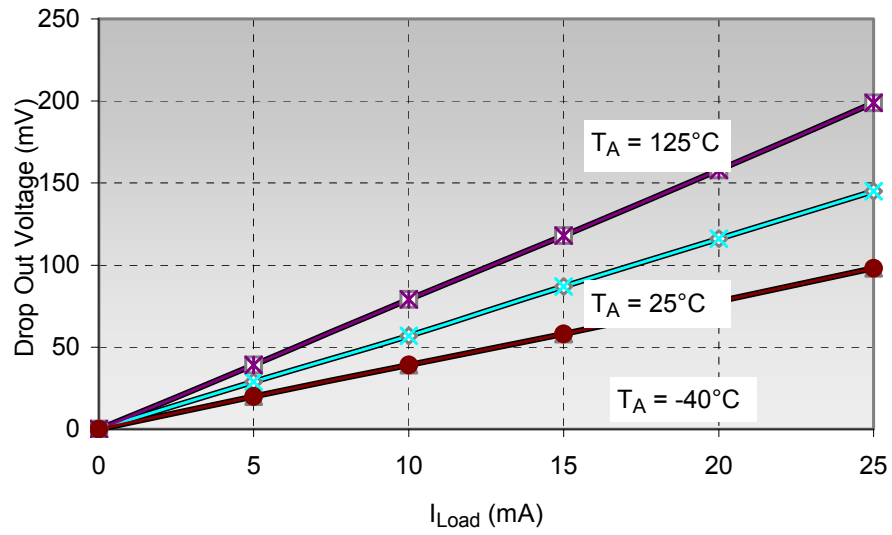

Figure 7. Dropout Voltage on HVDD vs. I<sub>LOAD</sub>

## FUNCTIONAL DESCRIPTION

### INTRODUCTION

The 908E625 device was designed and developed as a highly integrated and cost effective solution for automotive and industrial applications. For automotive body electronics, the 908E625 is well suited to perform complete mirror, door lock, and light-levelling control all via a three-wire LIN bus.

This device combines an standard HC08 MCU core (68HC908EY16) with flash memory together with a SMARTMOS IC chip. The SMARTMO™ IC chip combines power and control in one chip. Power switches are provided on the SMARTMOS IC configured as half-bridge outputs with

one high side switch. Other ports are also provided; they include Hall-effect sensor input ports, analog input ports, and a selectable HVDD pin. An internal voltage regulator is provided on the SMARTMOS IC chip, which provides power to the MCU chip.

Also included in this device is a LIN physical layer, which communicates using a single wire. This enables the device to be compatible with three-wire bus systems, where one wire is used for communication, one for battery, and the third for ground.

### FUNCTIONAL PIN DESCRIPTION

See [Figure 1](#) for a graphic representation of the various pins referred to in the following paragraphs. Also, see the pin diagram on [Figure 3](#) for a depiction of the pin locations on the package.

#### PORT A I/O PINS (PTA0:4)

These pins are special-function, bidirectional I/O port pins that are shared with other functional modules in the MCU. PTA0:PTA4 are shared with the keyboard interrupt pins, KBD0:KBD4.

The PTA5/SPSCK pin is not accessible in this device and is internally connected to the SPI clock pin of the analog die. The PTA6/ $\overline{SS}$  pin is likewise not accessible.

For details refer to the 68HC908EY16 datasheet.

#### PORT B I/O PINS (PTB1, PTB3:7)

These pins are special function, bi-directional I/O port pins that are shared with other functional modules in the MCU. All pins are shared with the ADC module. The PTB6:PTB7 pins are also shared with the Timer B module.

PTB0/AD0 is internally connected to the ADOUT pin of the analog die, allowing diagnostic measurements to be calculated; e.g., current recopy,  $V_{SUP}$ , etc. The PTB2/AD2 pin is not accessible in this device.

For details refer to the 68HC908EY16 datasheet.

#### PORT C I/O PINS (PTC2:4)

These pins are special function, bi-directional I/O port pins that are shared with other functional modules in the MCU. For example, PTC2:PTC4 are shared with the ICG module.

PTC0/MISO and PTC1/MOSI are not accessible in this device and are internally connected to the MISO and MOSI SPI pins of the analog die.

For details refer to the 68HC908EY16 datasheet.

#### CURRENT LIMITATION FREQUENCY INPUT PIN (FGEN)

#### PORT D I/O PINS (PTD0:1)

PTD1/TACH1 and PTD0/TACH0/BEMF are special function, bi-directional I/O port pins that can also be programmed to be timer pins.

In step motor applications, the PTD0 pin should be connected to the BEMF output of the analog die, to evaluate the BEMF signal with a special BEMF module of the MCU.

PTD1 pin is recommended for use as an output pin for generating the FGEN signal (PWM signal), if required by the application.

#### PORT E I/O PIN (PTE1)

PTE1/RXD and PTE0/TXD are special function, bi-directional I/O port pins that can also be programmed to be enhanced serial communication.

PTE0/TXD is internally connected to the TXD pin of the analog die. The connection for the receiver must be done externally.

#### EXTERNAL INTERRUPT PIN ( $\overline{IRQ}$ )

The  $\overline{IRQ}$  pin is an asynchronous external interrupt pin. This pin contains an internal pull-up resistor that is always activated, even when the  $\overline{IRQ}$  pin is pulled LOW.

For details refer to the 68HC908EY16 datasheet.

#### EXTERNAL RESET PIN ( $\overline{RST}$ )

A Logic [0] on the  $\overline{RST}$  pin forces the MCU to a known startup state.  $\overline{RST}$  is bi-directional, allowing a reset of the entire system. It is driven LOW when any internal reset source is asserted.

This pin contains an internal pull-up resistor that is always activated, even when the reset pin is pulled LOW.

For details refer to the 68HC908EY16 datasheet.

Input pin for the half-bridge current limitation and the high side inrush current limiter PWM frequency. This input is not a

real PWM input pin; it should just supply the period of the PWM. The duty cycle will be generate automatically.

**Important** The recommended FGEN frequency should be in the range of 0.1 kHz to 20 kHz.

### BACK ELECTROMAGNETIC FORCE OUTPUT PIN (BEMF)

This pin gives the user information about back electromagnetic force (BEMF). This feature is mainly used in step motor applications for detecting a stalled motor. In order to evaluate this signal the pin must be directly connected to pin PTD0/TACH0/BEMF.

### RESET PIN ( $\overline{\text{RST\_A}}$ )

$\overline{\text{RST\_A}}$  is the bi-directional reset pin of the analog die. It is an open drain with pull-up resistor and must be connected to the  $\overline{\text{RST}}$  pin of the MCU.

### INTERRUPT PIN ( $\overline{\text{IRQ\_A}}$ )

$\overline{\text{IRQ\_A}}$  is the interrupt output pin of the analog die indicating errors or wake-up events. It is an open drain with pull-up resistor and must be connected to the  $\overline{\text{IRQ}}$  pin of the MCU.

### SLAVE SELECT PIN ( $\overline{\text{SS}}$ )

This pin is the SPI Slave Select pin for the analog chip. All other SPI connections are done internally.  $\overline{\text{SS}}$  must be connected to PTB1 or any other logic I/O of the microcontroller.

### LIN BUS PIN (LIN)

The LIN pin represents the single-wire bus transmitter and receiver. It is suited for automotive bus systems and is based on the LIN bus specification.

### HALF-BRIDGE OUTPUT PINS (HB1:HB4)

The 908E625 device includes power MOSFETs configured as four half-bridge driver outputs. The HB1:HB4 outputs may be configured for step motor drivers, DC motor drivers, or as high side and low-side switches.

The HB1:HB4 outputs are short-circuit and over-temperature protected, and they feature current recopy, current limitation, and BEMF generation. Current limitation and recopy are done on the low side MOSFETs.

### POWER SUPPLY PINS (VSUP1:VSUP3)

VSUP1:VSUP3 are device power supply pins. The nominal input voltage is designed for operation from 12 V systems. Owing to the low ON-resistance and current requirements of the half-bridge driver outputs and high side output driver, multiple VSUP pins are provided.

All VSUP pins must be connected to get full chip functionality.

### POWER GROUND PINS (GND1 AND GND2)

GND1 and GND2 are device power ground connections. Owing to the low ON-resistance and current requirements of the half-bridge driver outputs and high side output driver, multiple pins are provided.

GND1 and GND2 pins must be connected to get full chip functionality.

### HIGH SIDE OUTPUT PIN (HS)

The HS output pin is a low  $R_{\text{DS(ON)}}$  high side switch. The switch is protected against over-temperature and over-current. The output is capable of limiting the inrush current with an automatic PWM generation using the FGEN module.

### SWITCHABLE VDD OUTPUT PIN (HVDD)

The HVDD pin is a switchable  $V_{\text{DD}}$  output for driving resistive loads requiring a regulated 5.0 V supply; e.g., 3-pin Hall-effect sensors. The output is short-circuit protected.

### HALL-EFFECT SENSOR INPUT PINS (H1:H3)

The Hall-effect sensor input pins H1:H3 provide inputs for Hall-effect sensors and switches.

### +5.0 V VOLTAGE REGULATOR OUTPUT PIN (VDD)

The VDD pin is needed to place an external capacitor to stabilize the regulated output voltage. The VDD pin is intended to supply the embedded microcontroller.

**Important** The VDD pin should not be used to supply other loads; use the HVDD pin for this purpose. The VDD, EVDD, VDDA, and VREFH pins must be connected together.

### ANALOG INPUT PIN (PA1)

This pin is an analog input port with selectable current source values.

### VOLTAGE REGULATOR GROUND PIN (VSS)

The VSS pin is the ground pin for the connection of all non-power ground connections (microcontroller and sensors).

**Important** VSS, EVSS, VSSA, and VREFL pins must be connected together.

### LIN TRANSCEIVER OUTPUT PIN (RXD)

This pin is the output of LIN transceiver. The pin must be connected to the microcontroller's Enhanced Serial Communications Interface (ESCI) module (RXD pin).

### ADC REFERENCE PINS (VREFL AND VREFH)

VREFL and VREFH are the reference voltage pins for the ADC. It is recommended that a high quality ceramic decoupling capacitor be placed between these pins.

**Important** VREFH is the high reference supply for the ADC and should be tied to the same potential as VDDA via separate traces. VREFL is the low reference supply for the

ADC and should be tied to the same potential as VSS via separate traces.

For details refer to the 68HC908EY16 datasheet.

#### ADC SUPPLY PINS (VDDA AND VSSA)

VDDA and VSSA are the power supply pins for the analog-to-digital converter (ADC). It is recommended that a high quality ceramic decoupling capacitor be placed between these pins.

**Important** VDDA is the supply for the ADC and should be tied to the same potential as EVDD via separate traces. VSSA is the ground pin for the ADC and should be tied to the same potential as EVSS via separate traces.

For details refer to the 68HC908EY16 datasheet.

#### MCU POWER SUPPLY PINS (EVDD AND EVSS)

EVDD and EVSS are the power supply and ground pins. The MCU operates from a single power supply.

Fast signal transitions on MCU pins place high, short duration current demands on the power supply. To prevent noise problems, take special care to provide power supply bypassing at the MCU.

For details refer to the 68HC908EY16 datasheet.

#### TEST PIN (FLSVPP)

This pin is for test purposes only. This pin should be either left open (not connected) or connected to GND.

#### EXPOSED PAD PIN

The exposed pad pin on the bottom side of the package conducts heat from the chip to the PCB board. For thermal performance the pad must be soldered to the PCB board. It is recommended that the pad be connected to the ground potential.

## FUNCTIONAL DEVICE OPERATION

### OPERATIONAL MODES

#### INTERRUPTS

The 908E625 has seven different interrupt sources as described in the following paragraphs. The interrupts can be disabled or enabled via the SPI. After reset all interrupts are automatically disabled.

#### LOW VOLTAGE INTERRUPT

The low voltage interrupt (LVI) is related to the external supply voltage,  $V_{SUP}$ . If this voltage falls below the LVI threshold, it will set the LVI flag. If the low voltage interrupt is enabled, an interrupt will be initiated.

With LVI the H-Bridges (high side MOSFET only) and the high side driver are switched off. All other modules are not influenced by this interrupt.

During STOP mode the LVI circuitry is disabled.

#### HIGH VOLTAGE INTERRUPT

The high voltage interrupt (HVI) is related to the external supply voltage,  $V_{SUP}$ . If this voltage rises above the HVI threshold, it will set the HVI flag. If the high voltage interrupt is enabled, an interrupt will be initiated.

With HVI the H-Bridges (high side MOSFET only) and the high side driver are switched off. All other modules are not influenced by this interrupt.

During STOP mode the HVI circuitry is disabled.

#### HIGH TEMPERATURE INTERRUPT

The high temperature interrupt (HTI) is generated by the on-chip temperature sensors. If the chip temperature is above the HTI threshold, the HTI flag will be set. If the high temperature interrupt is enabled, an interrupt will be initiated.

During STOP mode the HTI circuitry is disabled.

#### AUTONOMOUS WATCHDOG INTERRUPT (AWD)

Refer to Autonomous Watchdog [Autonomous Watchdog \(AWD\)](#) on page 36.

#### LIN INTERRUPT

If the LINIE bit is set, a falling edge on the LIN pin will generate an interrupt. During STOP mode this interrupt will initiate a system wake-up.

#### HALL-EFFECT SENSOR INPUT PIN INTERRUPT

If the PHIE bit is set, the enabled Hall-effect sensor input pins H1:H3 can generate an interrupt if a current above the threshold is detected. During Stop mode this interrupt, combined with the cyclic wake-up feature of the AWD, can wake up the system. Refer to pin [Hall-Effect Sensor Input Pins \(H1:H3\)](#).

#### OVER-CURRENT INTERRUPT

If an over-current condition on a half-bridge occurs, the high side or the HVDD output is detected and the OCIE bit is set and an interrupt generated.

#### SYSTEM WAKE-UP

System wake-up can be initiated by any of four events:

- A falling edge on the LIN pin
- A wake-up signal from the AWD
- A Logic [1] at Hall-effect sensor input pin during cyclic check via AWD
- An LVR condition

If one of these wake-up events occurs and the interrupt mask bit for this event is set, the interrupt will wake-up the microcontroller as well as the main voltage regulator (MREG) ([Figure 8](#)).

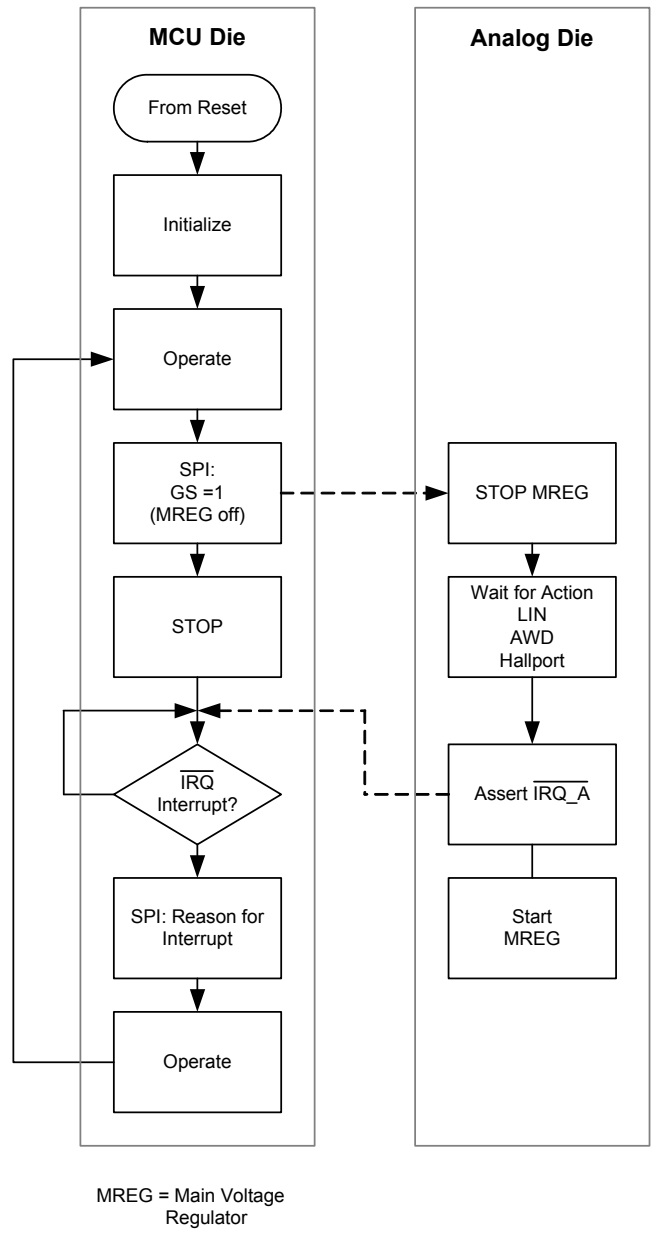

**Figure 8. STOP Mode/Wake-up Procedure**

## SERIAL SPI INTERFACE

The SPI creates the communication link between the microcontroller and the 908E625. The interface consists of four pins. See [Figure 9](#):

- $\overline{SS}$ —Slave Select

- MOSI—Master-Out Slave-In
- MISO—Master-In Slave-Out
- SPSCCK—Serial Clock

A complete data transfer via the SPI consists of 2 bytes. The master sends address and data, slave system status, and data of the selected address.

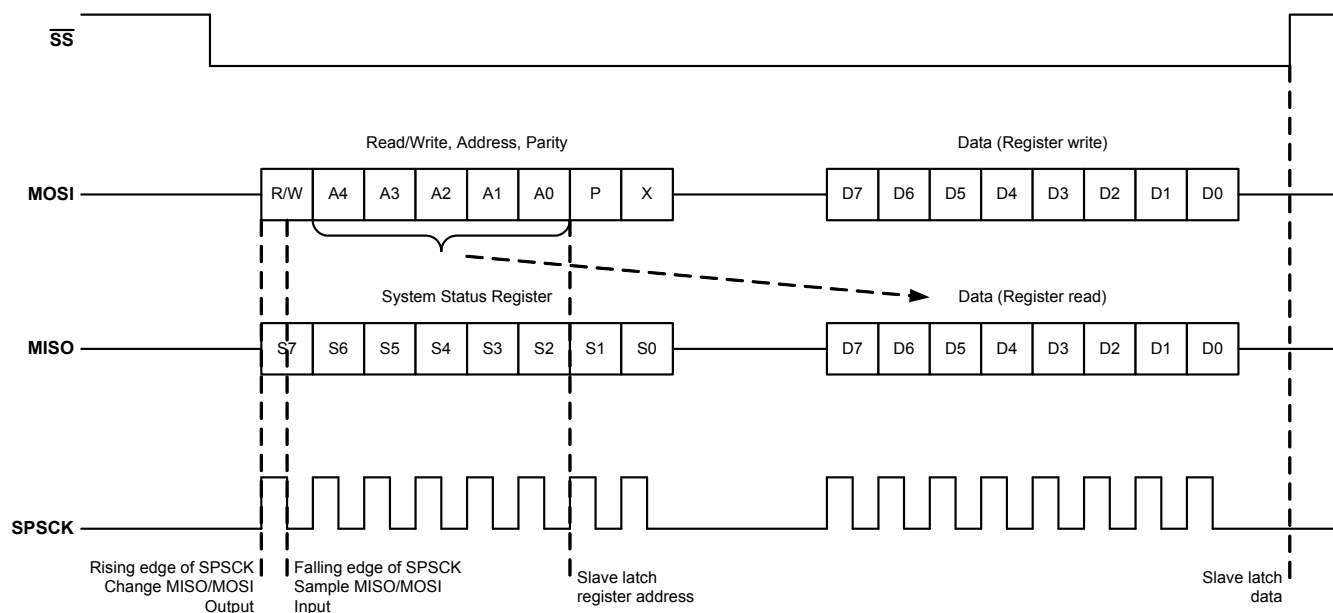

**Figure 9. SPI Protocol**

During the inactive phase of  $\overline{SS}$ , the new data transfer is prepared. The falling edge on the  $\overline{SS}$  line indicates the start of a new data transfer and puts MISO in the low-impedance mode. The first valid data are moved to MISO with the rising edge of SPSCCK.

The MISO output changes data on a rising edge of SPSCCK. The MOSI input is sampled on a falling edge of SPSCCK. The data transfer is only valid if exactly 16 sample clock edges are present in the active phase of  $\overline{SS}$ .

After a write operation, the transmitted data is latched into the register by the rising edge of  $\overline{SS}$ . Register read data is internally latched into the SPI at the time when the parity bit is transferred.  $\overline{SS}$  HIGH forces MISO to high impedance.

### A4:A0

Contains the address of the desired register.

### R/ $\overline{W}$

Contains information about a read or a write operation.

- If  $R/\overline{W} = 1$ , the second byte of master contains no valid information, slave just transmits back register data.
- If  $R/\overline{W} = 0$ , the master sends data to be written in the second byte, slave sends concurrently contents of selected register prior to write operation, write data is latched in the *SMARTMOS* register on rising edge of  $\overline{SS}$ .

### PARITY P

The parity bit is equal to 0 if the number of 1 bits is an even number contained within R/ $\overline{W}$ , A4:A0. If the number of 1 bits is odd, P equals 1. For example, if  $R/\overline{W} = 1$ , A4:A0 = 00001, then P equals 0.

The parity bit is only evaluated during a write operation.

### BIT X

Not used.

### MASTER DATA BYTE

Contains data to be written or no valid data during a read operation.

### SLAVE STATUS BYTE

Contains the contents of the System Status Register (\$0c) independent of whether it is a write or read operation or which register was selected.

### SLAVE DATA BYTE

Contains the contents of selected register. During a write operation it includes the register content prior to a write operation.

## SPI REGISTER OVERVIEW

**Table 6** summarizes the SPI register addresses and the bit names of each register.

**Table 6. List of Registers**

Addr	Register Name	R/W	Bit							
			7	6	5	4	3	2	1	0
\$01	H-Bridge Output (HBOUT)	R	HB4_H	HB4_L	HB3_H	HB3_L	HB2_H	HB2_L	HB1_H	HB1_L
		W								
\$02	H-Bridge Control (HBCTL)	R	OFC_EN	CSA	0	0	0	CLS2	CLS1	CLS0
		W								
\$03	System Control (SYSCTL)	R	PSON	SRS1	SRS0	0	0	0	0	0
		W								GS
\$04	Interrupt Mask (IMR)	R	0	HPIE	LINIE	HTIE	LVIE	HVIE	OCIE	0
		W								
\$05	Interrupt Flag (IFR)	R	0	HPF	LINF	HTF	LVF	HVF	OCF	0
		W								
\$06	Reset Mask (RMR)	R	TTEST	0	0	0	0	0	HVRE	HTRE
		W								
\$07	Analog Multiplexer Configuration (ADMUX)	R	0	0	0	0	SS3	SS2	SS1	SS0
		W								
\$08	Hall-Effect Sensor Input Pin Control (HACTL)	R	0	0	0	0	H3EN	H2EN	H1EN	
		W								
\$09	Hall-Effect Sensor Input Pin Status (HASTAT)	R	0	0	0	0	H3F	H2F	H1F	
		W								
\$0a	AWD Control (AWDCTL)	R	0	0	0	AWDRE	AWDIE	AWDCC	AWDF	AWDR
		W			AWDRST					
\$0b	Power Output (POUT)	R	0	0	CSSEL1	CSSEL0	CSEN1	CSEN0	HVDDON	HS_ON
		W								
\$0c	System Status (SYSSTAT)	R	HP_OCF	LINCL	HVDD_OC F	HS_OCF	LVF	HVF	HB_OCF	HTF
		W								

**LOGIC COMMANDS AND REGISTERS**

**INTERRUPT FLAG REGISTER (IFR)**

Register Name and Address: IFR - \$05

Bits	7	6	5	4	3	2	1	0
Read	0	HPF	LINF	HTF	LVF	HVF	OCF	0
Write								
Reset	0	0	0	0	0	0	0	0

**Hall-Effect Sensor Input Pin Flag Bit (HPF)**

This read/write flag is set depending on Run/Stop mode.

**RUN Mode**

An interrupt will be generated when a state change on any enabled Hall-effect sensor input pin is detected. Clear HPF by writing a Logic [1] to HPF. Reset clears the HPF bit. Writing a Logic [0] to HPF has no effect.

- 1 = State change on the hallflags detected
- 0 = No state change on the hallflags detected

**STOP Mode**

An interrupt will be generated when AWDCC is set and a current above the threshold is detected on any enabled Hall-effect sensor input pin. Clear HPF by writing a Logic [1] to HPF. Reset clears the HPF bit. Writing a Logic [0] to HPF has no effect.

- 1 = One or more of the selected Hall-effect sensor input pins had been pulled HIGH
- 0 = None of the selected Hall-effect sensor input pins has been pulled HIGH

**LIN Flag Bit (LINF)**

This read/write flag is set on the falling edge at the LIN data line. Clear LINF by writing a Logic [1] to LINF. Reset clears the LINF bit. Writing a Logic [0] to LINF has no effect.

- 1 = Falling edge on LIN data line has occurred
- 0 = Falling edge on LIN data line has not occurred since last clear

**High-Temperature Flag Bit (HTF)**

This read/write flag is set on a high temperature condition. Clear HTF by writing a Logic [1] to HTF. If a high temperature

condition is still present while writing a Logic [1] to HTF, the writing has no effect. Therefore, a high temperature interrupt cannot be lost due to inadvertent clearing of HTF. Reset clears the HTF bit. Writing a Logic [0] to HTF has no effect.

- 1 = High temperature condition has occurred
- 0 = High temperature condition has not occurred

**Low Voltage Flag Bit (LVF)**

This read/write flag is set on a low voltage condition. Clear LVF by writing a Logic [1] to LVF. If a low voltage condition is still present while writing a Logic [1] to LVF, the writing has no effect. Therefore, a low voltage interrupt cannot be lost due to inadvertent clearing of LVF. Reset clears the LVF bit. Writing a Logic [0] to LVF has no effect.

- 1 = Low voltage condition has occurred
- 0 = Low voltage condition has not occurred

**High Voltage Flag Bit (HVF)**

This read/write flag is set on a high voltage condition. Clear HVF by writing a Logic [1] to HVF. If high voltage condition is still present while writing a Logic [1] to HVF, the writing has no effect. Therefore, a high voltage interrupt cannot be lost due to inadvertent clearing of HVF. Reset clears the HVF bit. Writing a Logic [0] to HVF has no effect.

- 1 = High voltage condition has occurred
- 0 = High voltage condition has not occurred

**Over-current Flag Bit (OCF)**

This read-only flag is set on an over-current condition. Reset clears the OCF bit. To clear this flag, write a Logic [1] to the appropriate over-current flag in the SYSSTAT Register. See [Figure 10](#), illustrating the three signals triggering the OCF.

- 1 = High current condition has occurred
- 0 = High current condition has not occurred

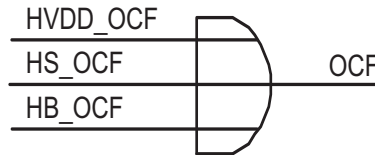

Figure 10. Principal Implementation for OCF

## INTERRUPT MASK REGISTER (IMR)

Register Name and Address: IMR - \$04

Bits	7	6	5	4	3	2	1	0
Read	0	HPIE	LINIE	HTIE	LVIE	HVIE	OCIE	0
Write								
Reset	0	0	0	0	0	0	0	0

### Hall-Effect Sensor Input Pin Interrupt Enable Bit (HPIE)

This read/write bit enables CPU interrupts by the Hall-effect sensor input pin flag, HPF. Reset clears the HPIE bit.

- 1 = Interrupt requests from HPF flag enabled
- 0 = Interrupt requests from HPF flag disabled

### LIN Line Interrupt Enable Bit (LINIE)

This read/write bit enables CPU interrupts by the LIN flag, LINF. Reset clears the LINIE bit.

- 1 = Interrupt requests from LINF flag enabled
- 0 = Interrupt requests from LINF flag disabled

### High Temperature Interrupt Enable Bit (HTIE)

This read/write bit enables CPU interrupts by the high temperature flag, HTF. Reset clears the HTIE bit.

- 1 = Interrupt requests from HTF flag enabled
- 0 = Interrupt requests from HTF flag disabled

### Low Voltage Interrupt Enable Bit (LVIE)

This read/write bit enables CPU interrupts by the low voltage flag, LVF. Reset clears the LVIE bit.

- 1 = Interrupt requests from LVF flag enabled
- 0 = Interrupt requests from LVF flag disabled

### High Voltage Interrupt Enable Bit (HVIE)

This read/write bit enables CPU interrupts by the high voltage flag, HVF. Reset clears the HVIE bit.

- 1 = Interrupt requests from HVF flag enabled
- 0 = Interrupt requests from HVF flag disabled

### Over-current Interrupt Enable Bit (OCIE)

This read/write bit enables CPU interrupts by the over-current flag, OCF. Reset clears the OCIE bit.

- 1 = Interrupt requests from OCF flag enabled
- 0 = Interrupt requests from OCF flag disabled

## RESET

The 908E625 chip has four internal reset sources and one external reset source, as explained in the paragraphs below. [Figure 11](#) depicts the internal reset sources.

## RESET INTERNAL SOURCES

### Autonomous Watchdog

AWD modules generates a reset because of a timeout (watchdog function).

### High Temperature Reset

To prevent damage to the device, a reset will be initiated if the temperature rises above a certain value. The reset is maskable with bit HTRE in the reset mask register. After a reset the high temperature reset is disabled.

### Low Voltage Reset

The LVR is related to the internal  $V_{DD}$ . In case the voltage falls below a certain threshold, it will pull down the  $\overline{RST\_A}$  pin.

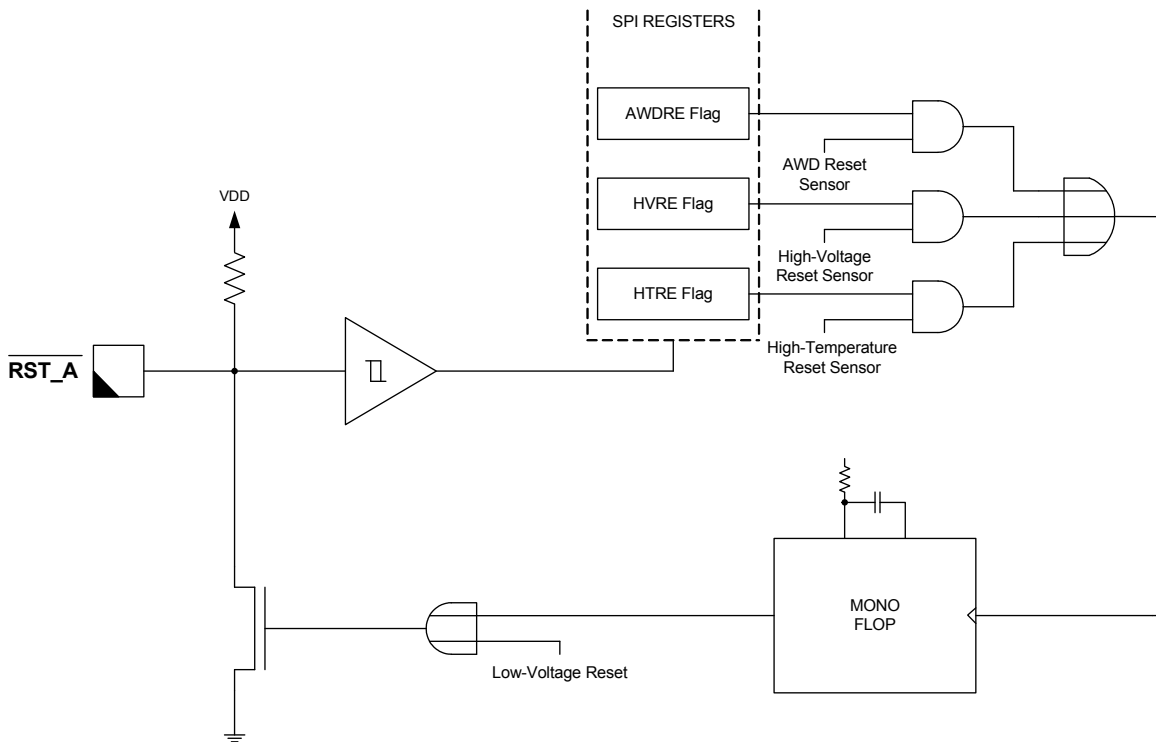

Figure 11. Internal Reset Routing

### High-Voltage Reset

The HVR is related to the external  $V_{SUP}$  voltage. In case the voltage is above a certain threshold, it will pull down the  $\overline{RST\_A}$  pin. The reset is maskable with bit HVRE in the Reset Mask Register. After a reset the high voltage reset is disabled.

### RESET EXTERNAL SOURCE

#### External Reset Pin

The microcontroller has the capability of resetting the SMARTMOS device by pulling down the  $\overline{RST}$  pin.

### RESET MASK REGISTER (RMR)

Register Name and Address: RMR - \$06

Bits	7	6	5	4	3	2	1	0
Read	TTEST	0	0	0	0	0	HVRE	HTRE
Write								
Reset	0	0	0	0	0	0	0	0

### High Temperature Reset Test (TTEST)

This read/write bit is for test purposes only. It decreases the over-temperature shutdown limit for final test. Reset clears the HTRE bit.

- 1 = Low temperature threshold enabled
- 0 = Low temperature threshold disabled

### High Voltage Reset Enable Bit (HVRE)

This read/write bit enables resets on high voltage conditions. Reset clears the HVRE bit.

- 1 = High voltage reset enabled
- 0 = High voltage reset disabled

### High Temperature Reset Enable Bit (HTRE)

This read/write bit enables resets on high temperature conditions. Reset clears the HTRE bit.

- 1 = High temperature reset enabled
- 0 = High temperature reset disabled

## ANALOG DIE I/Os

### LIN Physical Layer

The LIN bus pin provides a physical layer for single-wire communication in automotive applications. The LIN physical layer is designed to meet the LIN physical layer specification.

The LIN driver is a low side MOSFET with internal current limitation and thermal shutdown. An internal pull-up resistor with a serial diode structure is integrated, so no external pull-up components are required for the application in a slave node. The fall time from dominant to recessive and the rise time from recessive to dominant is controlled. The symmetry between both slew rate controls is guaranteed.

The LIN pin offers high susceptibility immunity level from external disturbance, guaranteeing communication during external disturbance.

The LIN transmitter circuitry is enabled by setting the PSON bit in the System Control Register (SYSCTL). If the transmitter works in the current limitation region, the LINCL bit in the System Status Register (SYSSTAT) is set. Due to excessive power dissipation in the transmitter, software is advised to monitor this bit and turn the transmitter off immediately.

### TXD PIN

The TXD pin is the MCU interface to control the state of the LIN transmitter (see [Figure 1](#)). When TXD is LOW, LIN output is low (dominant state). When TXD is HIGH, the LIN output MOSFET is turned off. The TXD pin has an internal pull-up current source in order to set the LIN bus in recessive state in the event, for instance, the microcontroller could not control it during system power-up or power-down.

### RXD PIN

The RXD transceiver pin is the MCU interface, which reports the state of the LIN bus voltage. LIN HIGH (recessive state) is reported by a high level on RXD, LIN LOW (dominant state) by a low level on RXD.

### STOP MODE/WAKE-UP FEATURE

During STOP mode operation the transmitter of the physical layer is disabled. The receiver pin is still active and able to detect wake-up events on the LIN bus line.

If LIN interrupt is enabled (LINIE bit in the Interrupt Mask Register is set), a falling edge on the LIN line causes an interrupt. This interrupt switches on the main voltage regulator and generates a system wake-up.

### Analog Multiplexer/ADOUT Pin

The ADOUT pin is the analog output interface to the ADC of the MCU. See [Figure 12](#). An analog multiplexer is used to read seven internal diagnostic analog voltages.

### Current Recopy

The analog multiplexer is connected to the four low side current sense circuits of the half-bridges. These sense circuits offer a voltage proportional to the current through the low side MOSFET. High or low resolution is selectable: 5.0 V/2.5 A or 5.0 V/500 mA, respectively. Refer to [Half-Bridge Current Recopy on page 32](#).)

### Analog Input PA1

The analog input PA1 is directly connected to the analog multiplexer, permitting analog values from the periphery to be read.

## TEMPERATURE SENSOR

The 908E625 includes an on-chip temperature sensor. This sensor offers a voltage that is proportional to the actual chip junction temperature.

### V<sub>SUP</sub> PRESCALER

The V<sub>SUP</sub> prescaler permits the reading or measurement of the external supply voltage. The output of this voltage is V<sub>SUP</sub>/RATIO<sub>V<sub>SUP</sub></sub>.

The different internal diagnostic analog voltages can be selected with the ADMUX Register.

## ANALOG MULTIPLEXER CONFIGURATION REGISTER (ADMUX)

Register Name and Address: ADMUX - \$07

Bits	7	6	5	4	3	2	1	0
Read	0	0	0	0	SS3	SS2	SS1	SS0
Write								
Reset	0	0	0	0	0	0	0	0

### SS3, SS2, SS1, and SS0—A/D Input Select Bits

These read/write bits select the input to the ADC in the microcontroller according to [Table 7](#). Reset clears SS3, SS2, SS1, and SS0 bits.

**Table 7. Analog Multiplexer Configuration Register**

SS3	SS2	SS1	SS0	Channel
0	0	0	0	Current Recopy HB1
0	0	0	1	Current Recopy HB2
0	0	1	0	Current Recopy HB3
0	0	1	1	Current Recopy HB4
0	1	0	0	V <sub>SUP</sub> Prescaler
0	1	0	1	Temperature Sensor
0	1	1	0	Not Used
0	1	1	1	PA1 Pin
1	0	0	0	Not Used
1	0	0	1	
1	0	1	0	
1	0	1	1	
1	1	0	0	
1	1	0	1	
1	1	1	0	
1	1	1	1	

**ANALOG INPUT PA1**

The Analog input PA1 pin provides an input for reading analog signals and is internally connected to the analog multiplexer. It can be used for reading switches, potentiometers or resistor values, etc.

**ANALOG INPUT PA1 CURRENT SOURCE**

The analog input PA1 has an additional selectable current source. It enables the reading of switches, NTC, etc., without the need of an additional supply line for the sensor illustrated in [Figure 12](#). With this feature it is also possible to read multiple switches on one input.

Current source is enabled if the PSON bit in the System Control Register (SYSCCTL) and the CSEN bit in the Power Output Register (POUT) is set.

Four different current source values can be selected with the CSSELx bits shown in [Table 8](#). This function ceases during STOP mode operation.

**Table 8. PA1 Current Source Level Selection Bits**

CSSEL1	CSSEL0	Current Source Enable (typ.)
0	0	10%
0	1	30%
1	0	60%
1	1	100%

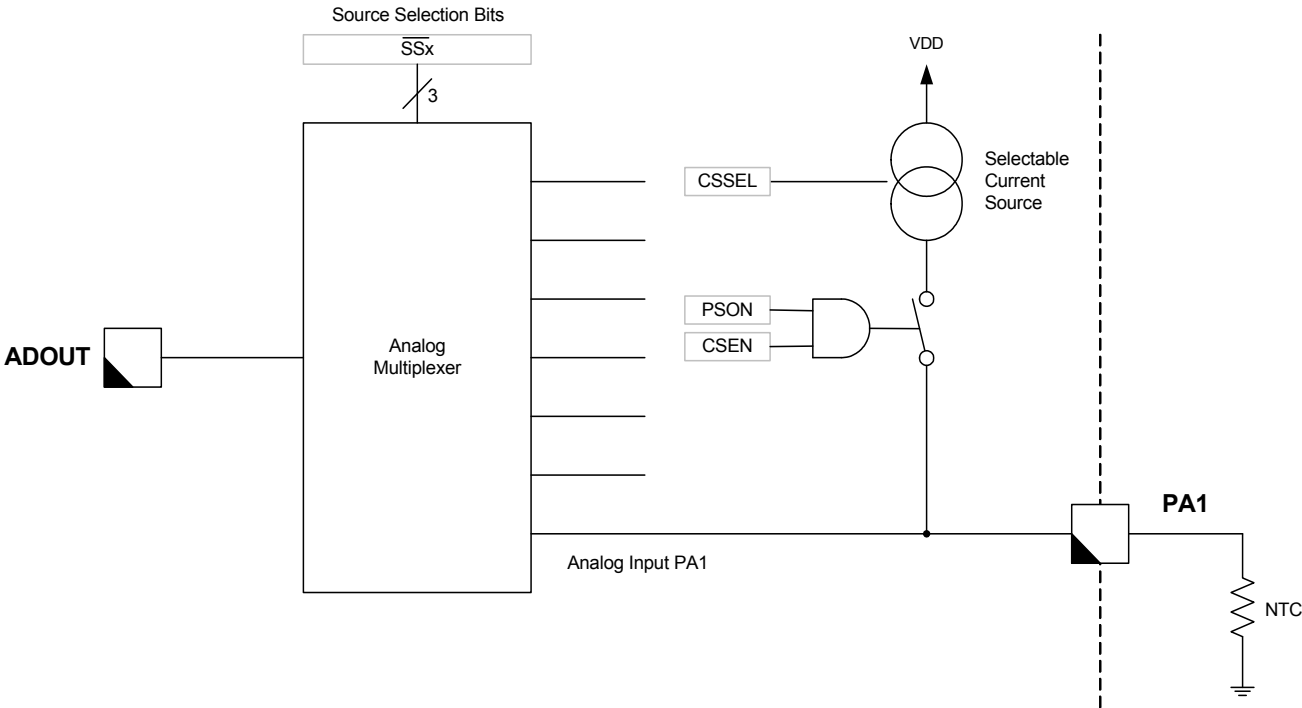

**Figure 12. Analog Input PA1 and Multiplexer**

## POWER OUTPUT REGISTER (POUT)

Register Name and Address: POUT - \$0b

Bits	7	6	5	4	3	2	1	0
Read	0	0	CSSEL1	CSSEL0	CSEN	0 <sup>(16)</sup>	HVDDON	HS_ON
Write								
Reset	0	0	0	0	0	0	0	0

### Notes

- 16. This bit must always be set to 0.

### Current Source Select Bits (CSSEL0:CSSEL1)

These read/write bits select the current source values. Reset clears the CSSEL0:CSSEL1 bits.

### Current Source Enable Bit (CSEN)

This read/write bit enables the current source for PA1. Reset clears the CSEN bit (Table 9).

**Table 9. PA1 Current Source Enable Bit**

CSEN	Current Source Enable
0	Current Source Off
1	Current Source On

### HVDD On Bit (HVDDON)

This read/write bit enables HVDD output. Reset clears the HVDDON bit.

- 1 = HVDD enabled
- 0 = HVDD disabled

### Lamp Driver On Bit (HS\_ON)

This read/write bit enables the Lamp driver. Reset clears the HS\_ON bit.

- 1 = Lamp driver enabled
- 0 = Lamp driver disabled

## Hall-Effect Sensor Input Pins (H1:H3)

### Function

The Hall-effect sensor input pins provide three inputs for two-pin Hall-effect sensors for detecting stall and position or reading Hall-effect sensor contact switches. The Hall-effect sensor input pins are not influenced by the PSON bit in the System Control Register.

Each pin of the Hall-effect sensor can be enabled by setting the HxEN bit in the Hall-effect sensor input pin control register (HACTL). If the pins are enabled, the Hall-effect sensors are supplied with  $V_{SUP}$  voltage and the sense circuitry is working. An internal clamp circuitry limits the supply voltage to the sensor to 15 V. This sense circuitry monitors the current to VSS. The result of this sense operation is given by the HxF flags in the Hall-effect sensor input pin status register (HASTAT).

The flag is set if the sensed current is higher than  $I_{HSC}$ . To prevent noise on this flag, a hysteresis is implemented on these pins.

After switching on the Hall-effect sensor input pins (HxEN = 1), the Hall-effect sensors need some time to stabilize the output. In RUN mode the software must wait at least 40  $\mu$ s between enabling the Hall-effect sensor and reading the hall flag.

The Hall-effect sensor input pin works in a dynamic output voltage range from  $V_{SUP}$  down to 2.0 V. Below 2.0 V the hallflags are not functional anymore. If the output voltage is below a certain threshold, the Hall-effect sensor input pin over-current flag (HP\_OCF) in the system status register is set.

Figures 13 through 15 illustrate the connections to the Hall-effect input sensors.

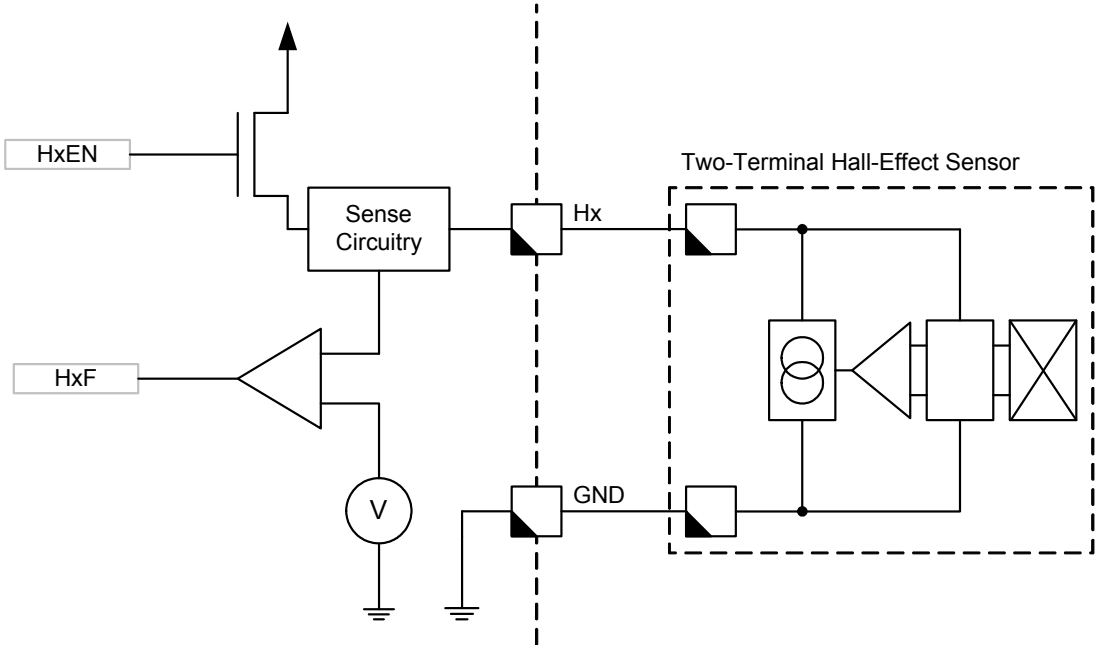

Figure 13. Hall-effect Sensor Input Pin Connected to Two Pin Hall-effect Sensor

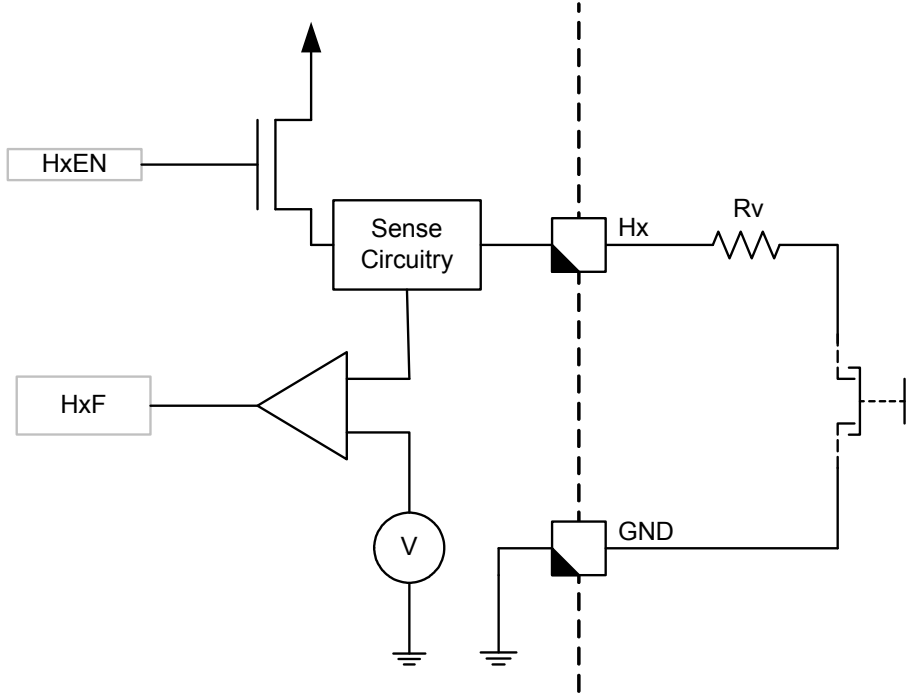

Figure 14. Hall-effect Sensor Input Pin Connected to Local Switch

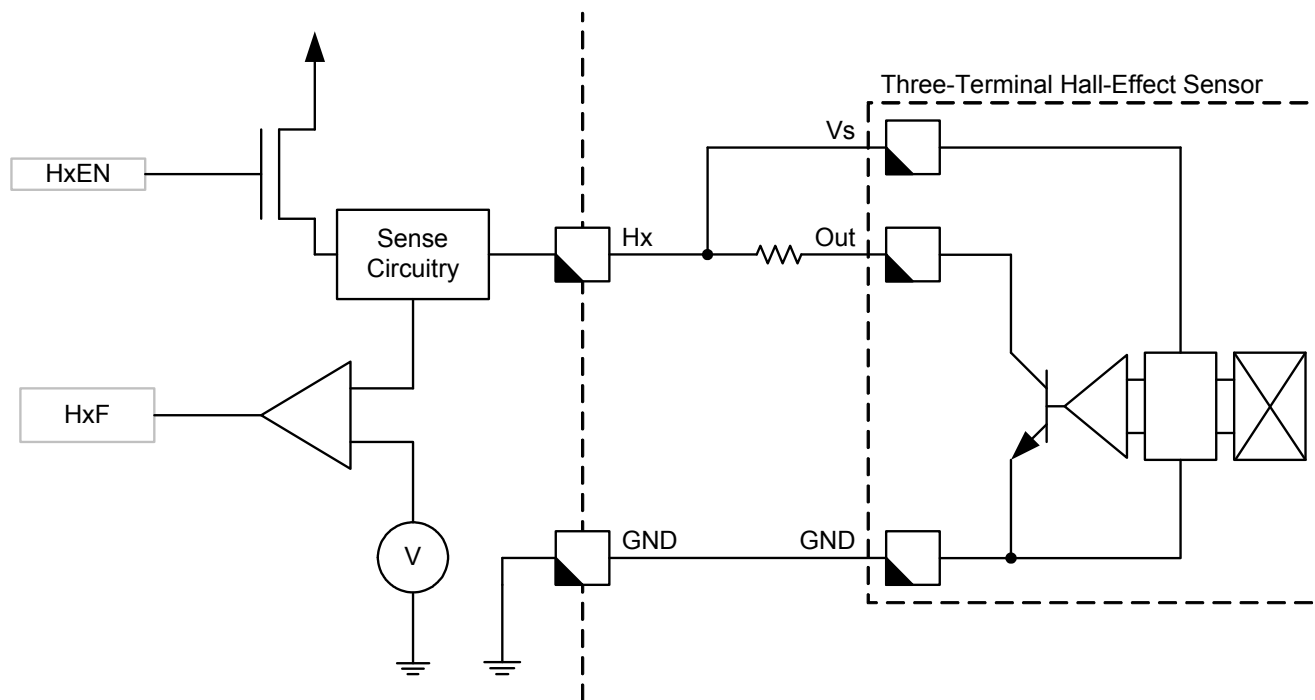

Figure 15. Hall-effect Sensor Input Pin Connected to Three Pin Hall-effect Sensor

### Interrupts

The Hall-effect sensor input pins are interrupt capable. How and when an interrupt occurs is dependent on the operating mode, RUN or Stop.

### RUN Mode

In RUN mode the Hall-effect sensor input pin interrupt flag (HPF) will be set if a state change on the hallflags (HxF) is detected. The interrupt is maskable with the HPIE bit in the interrupt mask register. Before enabling the interrupt, the flag should be cleared in order to prevent a wrong interrupt.

### STOP Mode

In STOP mode the Hall-effect sensor input pins are disabled independent of the state of the HxEN flags.

### CYCLIC WAKE-UP

The Hall-effect sensor inputs can be used to wake up the system. This wake-up function is provided by the cyclic check wake-up feature of the AWD (Autonomous Watchdog).

If the cyclic check wake-up feature is enabled (AWDCC bit is set), the AWD switches on the enabled Hall-effect sensor pins periodically. To ensure that the Hall-effect sensor current is stabilized after switching on, the inputs are sensed after  $\sim 40 \mu\text{s}$ . If a 1 is detected ( $I_{\text{Hall sensor}} > I_{\text{HSCT}}$ ) and the interrupt mask bit HPIE is set, an interrupt is performed. This wakes up the MCU and starts the main voltage regulator.

The wake-up function via this input is available when all three conditions exist:

- The two-pin Hall-effect sensor input is enabled (HxEN = 1)
- The cyclic wake-up of the AWD is enabled (AWDCC = 1); see [Figure 16](#)
- The Hall-effect sensor input pin interrupt is enabled (HPIE = 1)

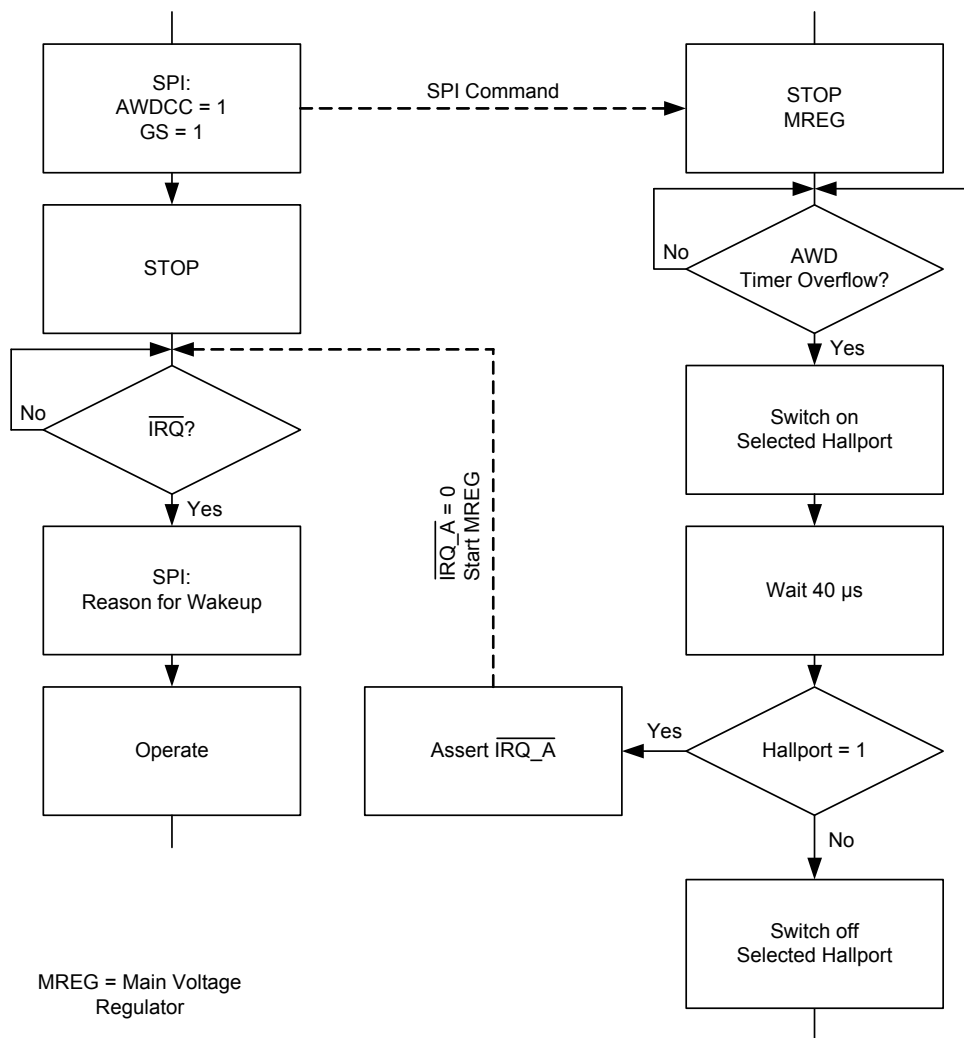

Figure 16. Hall-effect Sensor Input Pin Cyclic Check Wake-up Feature

**HALL-EFFECT SENSOR INPUT PIN CONTROL REGISTER (HACTL)**

**HALL-EFFECT SENSOR INPUT PIN STATUS REGISTER (HASTAT)**

Register Name and Address: HACTL - \$08

Register Name and Address: HASTAT - \$09

Bits	7	6	5	4	3	2	1	0
Read	0	0	0	0	0	H3EN	H2EN	H1EN
Write								
Reset	0	0	0	0	0	0	0	0

Bits	7	6	5	4	3	2	1	0
Read	0	0	0	0	0	H3F	H2F	H1F
Write								
Reset	0	0	0	0	0	0	0	0

**Hall-Effect Sensor Input Pin Enable Bits (H3EN:H1EN)**

These read/write bits enable the Hall-effect sensor input pins. Reset clears the H3EN:H1EN bits.

- 1 = Hall-effect sensor input pin Hx switched on and sensed
- 0 = Hall-effect sensor input pin Hx disabled

**Hall-Effect Sensor Input Pin Flag Bits (H3F:H1F)**

These read-only flag bits reflect the input Hx while the Hall-effect sensor input pin Hx is enabled (HxEN = 1). Reset clears the H3F:H1F bits.

- 1 = Hall-effect sensor input pin current above threshold
- 0 = Hall-effect sensor input pin current below threshold

## HALF-BRIDGES

Outputs HB1:HB4 provide four low-resistive half-bridge output stages. The half-bridges can be used in H-Bridge, high side, or low side configurations.

Reset clears all bits in the H-Bridge output register (HBOUT) owing to the fact that all half-bridge outputs are switched off.

HB1:HB4 output features:

- Short-circuit (over-current) protection on high side and low side MOSFETs
- Current recopy feature (low side MOSFET)
- Over-temperature protection
- Over-voltage and under-voltage protection
- Current limitation feature (low side MOSFET)

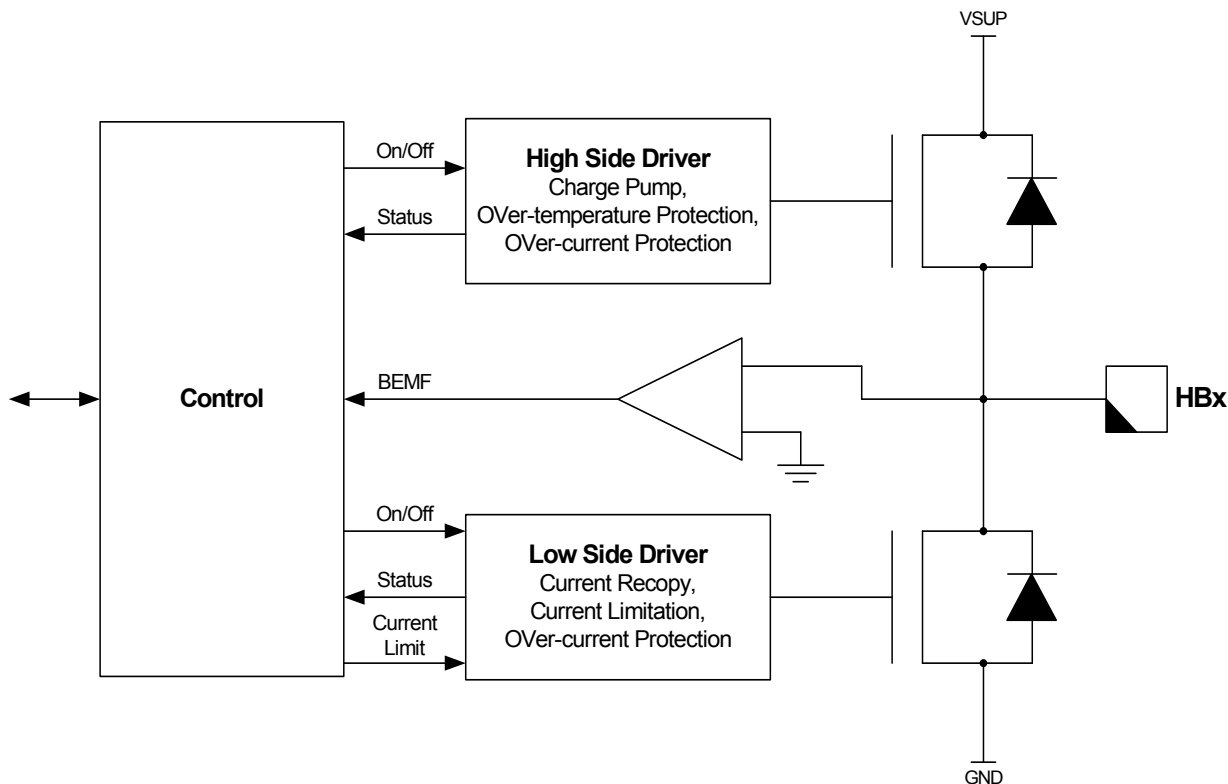

Figure 17. Half-bridge Push-Pull Output Driver

## HALF-BRIDGE CONTROL

Each output MOSFET can be controlled individually. The general enable of the circuitry is done by setting PSON in the system control register (SYSCTL). HBx\_L and HBx\_H form one half-bridge. It is not possible to switch on both MOSFETs in one half-bridge at the same time. If both bits are set, the high-side MOSFET has a higher priority.

To avoid both MOSFETs (high side and low side) of one half-bridge being on at the same time, a break-before-make circuit exists. Switching the high side MOSFET on is inhibited as long as the potential between gate and  $V_{SS}$  is not below a certain threshold. Switching the low side MOSFET on is blocked as long as the potential between gate and source of the high-side MOSFET did not fall below a certain threshold.

## HALF-BRIDGE OUTPUT REGISTER (HBOUT)

Register Name and Address: HBOUT - \$01

Bits	7	6	5	4	3	2	1	0
Read	HB4_H	HB4_L	HB3_H	HB3_L	HB2_H	HB2_L	HB1_H	HB1_L
Write								
Reset	0	0	0	0	0	0	0	0

### Low Side On/Off Bits (HBx\_L)

These read/write bits turn on the low side MOSFETs. Reset clears the HBx\_L bits.

- 1 = Low side MOSFET turned on for half-bridge output x
- 0 = Low side MOSFET turned off for half-bridge output x

### High Side On/Off Bits (HBx\_H)

These read/write bits turn on the high side MOSFETs. Reset clears the HBx\_H bits.

- 1 = High side MOSFET turned on for half-bridge output x
- 0 = High side MOSFET turned on for half-bridge output x

### HALF-BRIDGE CURRENT LIMITATION

Each low side MOSFET offers a current limit or constant current feature. This features is realized by a pulse width modulation on the low side MOSFET. The pulse width modulation on the outputs is controlled by the FGEN input

and the load characteristics. The FGEN input provides the PWM frequency, whereas the duty cycle is controlled by the load characteristics.

The recommended frequency range for the FGEN and the PWM is 0.1 kHz to 20 kHz.

### Functionality

Each low side MOSFET switches off if a current above the selected current limit was detected. The 908E625 offers five different current limits. Refer to [Table 10](#) for current limit values. The low side MOSFET switches on again if a rising edge on the FGEN input was detected ([Figure 18](#)).

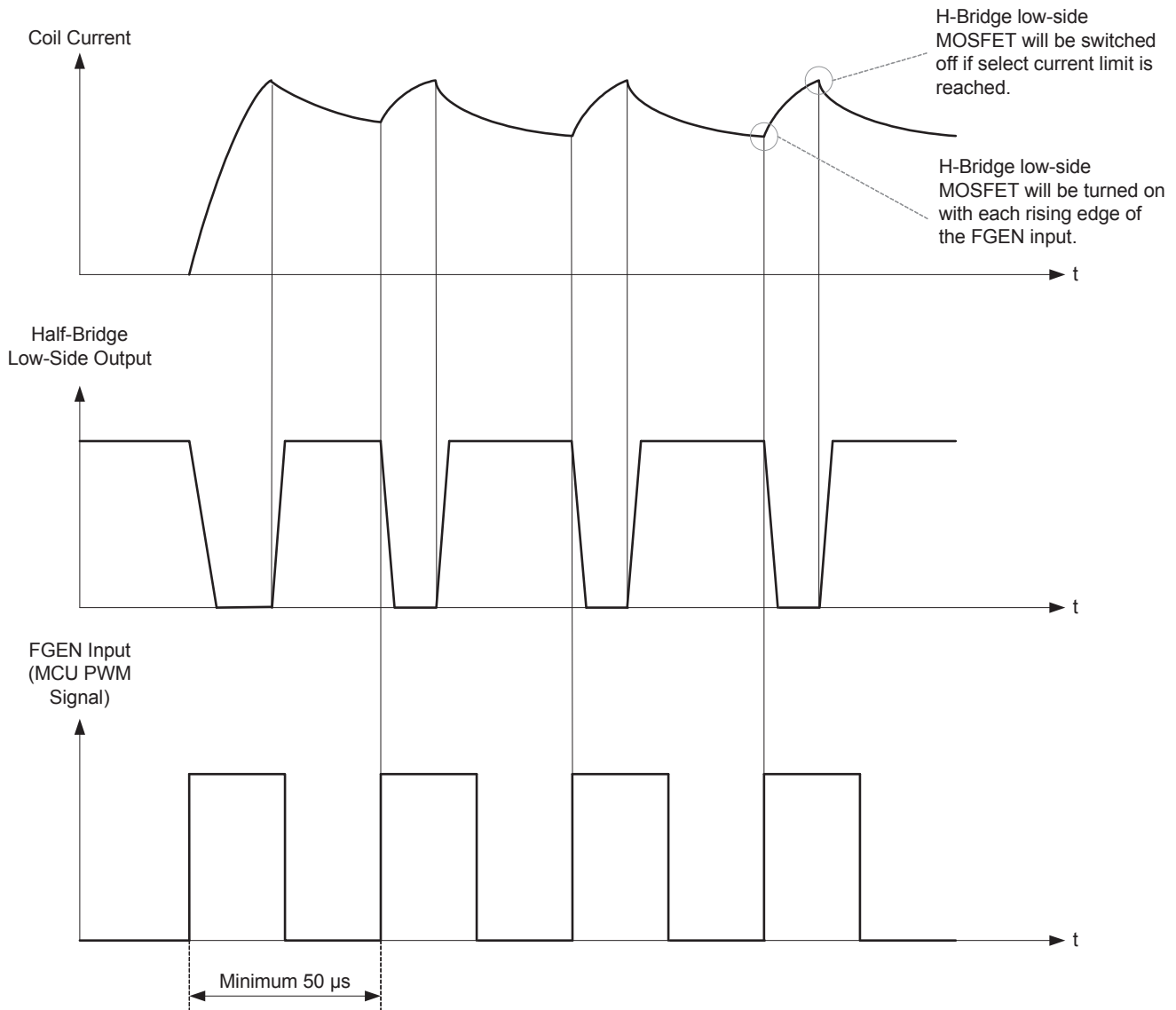

Figure 18. Half-bridge Current Limitation

### OFFSET CHOPPING

If bit OFC\_EN in the H-Bridge control register (HBCTL) is set, HB1 and HB2 will continue to switch on the low side MOSFETs with the rising edge of the FGEN signal and HB3

and HB4 will switch on the low side MOSFETs with the falling edge on the FGEN input. In step motor applications this feature allows the reduction of EMI due to a reduction of the di/dt ([Figure 19](#)).

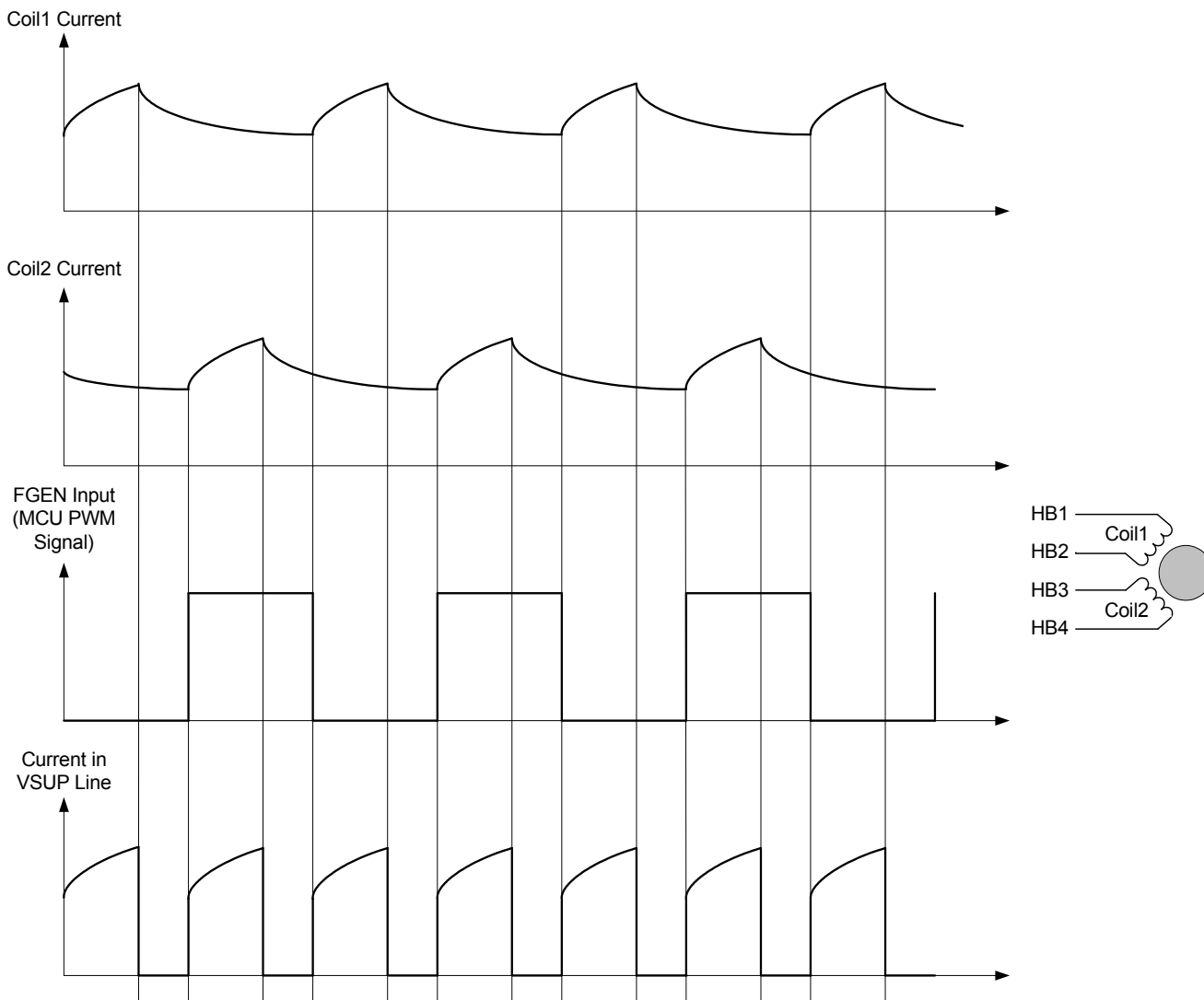

Figure 19. Offset Chopping for Step Motor Control

### HALF-BRIDGE CURRENT RECOPY

Each low side MOSFET has an additional sense output to allow a current recopy feature. This sense source is internally connected to a shunt resistor. The drop voltage is amplified and switched to the analog multiplexer.

The factor for the current sense amplification can be selected via bit CSA in the system control register.

- CSA = 1: Low resolution selected (500 mA measurement range)
- CSA = 0: High resolution selected (2.5 A measurement range)

### HALF-BRIDGE BEMF GENERATION

The BEMF output is set to 1 if a recirculation current is detected in any half-bridge. This recirculation current flows via the two freewheeling diodes of the power MOSFETs. The BEMF circuitry detects that and generates a HIGH on the BEMF output as long as a recirculation current is detected. This signal provides a flexible and reliable detection of stall in step motor applications. For this the BEMF circuitry takes advantage of the instability of the electrical and mechanical behavior of a step motor when blocked. In addition the signal can be used for open load detection (absence of this signal), see [Figure 20](#).

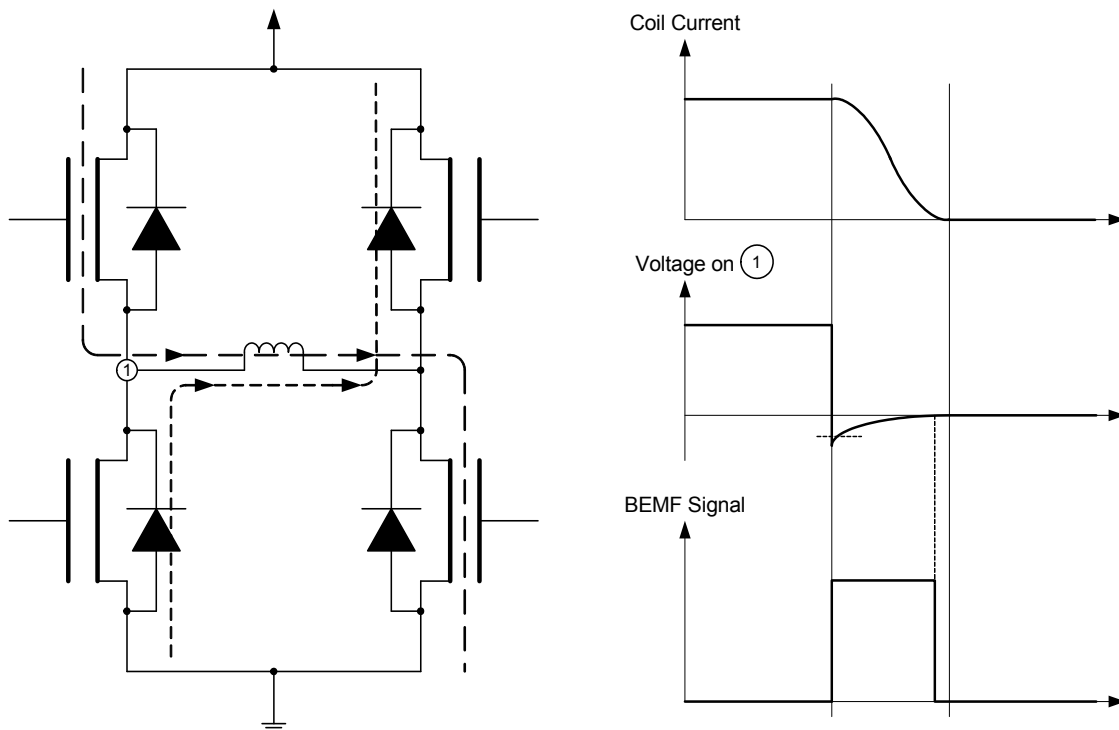

Figure 20. BEMF Signal Generation

### HALF-BRIDGE OVER-TEMPERATURE PROTECTION

The half-bridge outputs provide an over-temperature pre-warning with the HTF in the Interrupt Flag Register (IFR). In order to protect the outputs against over-temperature, the high temperature reset must be enabled. If this value is reached, the part generates a reset and disables all power outputs.

### HALF-BRIDGE OVER-CURRENT PROTECTION

The half-bridges are protected against short to GND, short to VSUP, and load shorts.

In the event an over-current on the high side is detected, the high side MOSFETs on all HB high side MOSFETs are switched off automatically. In the event an over-current on the low side is detected, all HB low side MOSFETs are switched off automatically. In both cases the over-current status flag HB\_OCF in the system status register (SYSSTAT) is set.

The over-current status flag is cleared (and the outputs re-enabled) by writing a Logic [1] to the HB\_OCF flag in the System status register or by reset.

### HALF-BRIDGE OVER-VOLTAGE/UNDER-VOLTAGE

The half-bridge outputs are protected against under-voltage and over-voltage conditions. This protection is done by the low and high voltage interrupt circuitry. If one of these flags (LVF, HVF) is set, the outputs are automatically disabled.

The over-voltage/under-voltage status flags are cleared (and the outputs re-enabled) by writing a Logic [1] to the LVF/HVF flags in the interrupt flag register or by reset. Clearing this flag is useless as long as a high or low voltage condition is present.

### HALF-BRIDGE CONTROL REGISTER (HBCTL)

Register Name and Address: HBCTL - \$02

Bits	7	6	5	4	3	2	1	0
Read	OFC_EN	CSA	0	0	0	CLS2	CLS1	CLS0
Write								
Reset	0	0	0	0	0	0	0	0

#### H-Bridge Offset Chopping Enable Bit (OFC\_EN)

This read/write bit enables offset chopping. Reset clears the OFC\_EN bit.

- 1 = Offset chopping enabled
- 0 = Offset chopping disabled

#### H-Bridges Current Sense Amplification Select Bit (CSA)

This read/write bit selects the current sense amplification of the H-Bridges. Reset clears the CSA bit.

- 1 = Current sense amplification set for measuring 0.5 A.
- 0 = Current sense amplification set for measuring 2.5 A.

### H-Bridge Current Limitation Selection Bits (CLS2:CLS0)

These read/write bits select the current limitation value according to [Figure 10](#). Reset clears the CLS2:CLS0 bits.

**Table 10. H-Bridge Current Limitation Value Selection Bits**

CLS2	CLS1	CLS0	Current Limit
0	0	0	No Limit
0	0	1	
0	1	0	
0	1	1	55 mA (typ)
1	0	0	260 mA (typ)
1	0	1	370 mA (typ)
1	1	0	550 mA (typ)
1	1	1	740 mA (typ)

### HIGH SIDE DRIVER

The high side output is a low-resistive high side switch targeted for driving lamps. The high side is protected against over-temperature. To limit the high inrush current of bulbs, over-current protection circuitry is used to limit the current. The output is enabled with bit PSON in the system control register and can be switched on/off with bit HS\_ON in the power output register. [Figure 21](#) depicts the high-side switch circuitry and connection to external lamp.

### HIGH-SIDE OVER-VOLTAGE/UNDER-VOLTAGE PROTECTION

The high side output pin, HS, is protected against under-voltage/over-voltage conditions. This protection is done by the low and high voltage interrupt circuitry. If one of these flags (LVF, HVF) is set, the output is disabled.

The over-voltage/under-voltage status flags are cleared and the output re-enabled by writing a Logic [1] to the LVF/HVF flags in the interrupt flag register or by reset. Clearing this flag is useless as long as a high or low voltage condition is present.

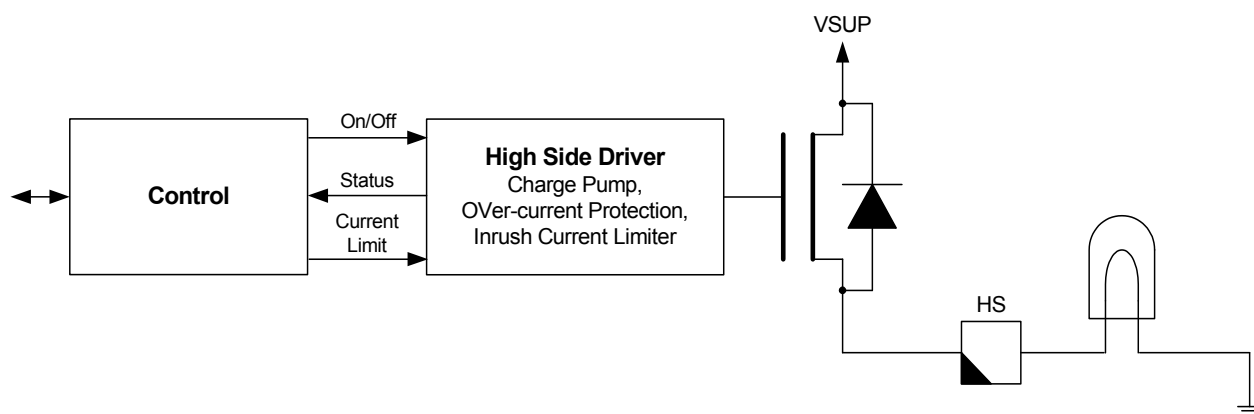

**Figure 21. High Side Circuitry**

### HIGH SIDE OVER-TEMPERATURE PROTECTION

The high side output provides an over-temperature pre-warning with the HTF in the interrupt flag register. In order to protect the output against over-temperature, the high-temperature reset must be enabled. If this value is reached, the part generates a reset and disables all power outputs.

### HIGH-SIDE OVER-CURRENT PROTECTION

The high side output is protected against over-current. In the event over-current limit is or was reached, the output automatically switches off and the over-current flag is set.

Due to the high inrush current of bulbs, a special feature of the 908E625 prevents an over-current shutdown during this

inrush. If an PWM frequency is supplied to the FGEN output during the switching on of a bulb, the inrush current is limited to the over-current shutdown limit. This means if the current reaches the over-current shutdown, the high side will be switched off, but each rising edge on the FGEN input will enable the driver again.

To distinguish between a shutdown due to an inrush current or a real shutdown, the software must check if the over-current status flag (HS\_OCF) in the System Status Register is set beyond a certain period of time. The over-current status flag is cleared by writing a Logic [1] to the HS\_OCF in the System Status Register, see [Figure 22](#).

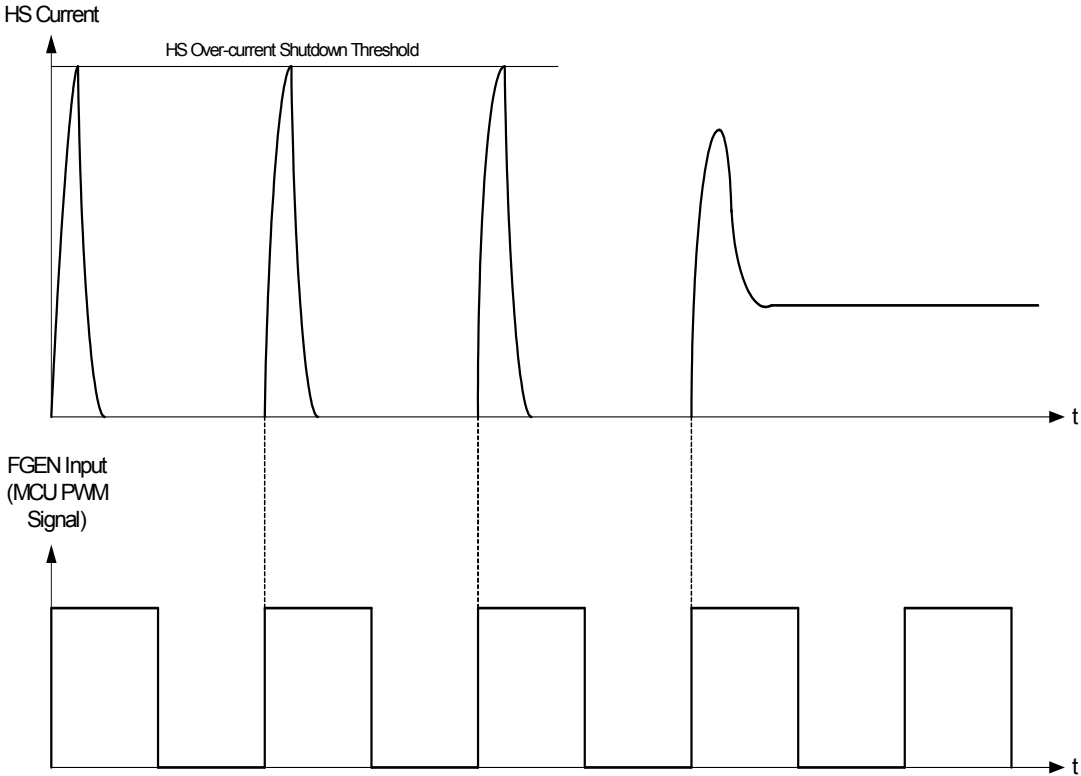

Figure 22. Inrush Current Limiter on High Side Output

**SWITCHABLE VDD OUTPUT (HVDD)**

The HVDD pin is a switchable VDD output pin. It can be used for driving external circuitry that requires a  $V_{DD}$  voltage. The output is enabled with bit PS0N in the system control register and can be switched on/off with bit HVDDON in the power output register. Low or high voltage conditions (LVI/HVI) have no influence on this circuitry.

**HVDD OVER-TEMPERATURE PROTECTION**

Over-temperature protection is enabled if the high temperature reset is enabled.

**HVDD OVER-CURRENT PROTECTION**

The HVDD output is protected against over-current. In the event the over-current limit is or was reached, the output automatically switches off and the HVDD over-current flag in the system status register is set.

**SYSTEM CONTROL REGISTER (SYSCTL)**

Register Name and Address: SYSCTL - \$03

Bits	7	6	5	4	3	2	1	0
Read	PS0N	SRS1	SRS0	0	0	0	0	0
Write								GS
Reset	0	0	0	0	0	0	0	0

**Power Stages On Bit (PS0N)**

This read/write bit enables the power stages (half-bridges, high side, LIN transmitter, Analog Input PA1 current sources, and HVDD output). Reset clears the PS0N bit.

- 1 = Power stages enabled.
- 0 = Power stages disabled.

**LIN Slew Rate Selection Bits (SRS0:SRS1)**

These read/write bits enable the user to select the appropriate LIN slew rate for different baud rate configurations as shown in [Table 11](#).

The high speed slew rates are used, for example, for programming via the LIN and are not intended for use in the application.

**Table 11. LIN Slew Rate Selection Bits**

SRS1	SRS0	LIN Slew Rate
0	0	Initial Slew Rate (20 kBaud)
0	1	Slow Slew Rate (10 kBaud)
1	0	High Speed II (8x)
1	1	High Speed I (4x)

**Go to STOP Mode Bit (GS)**

This write-only bit instructs the 908E625 to power down and go into Stop mode. Reset or CPU interrupt requests clear the GS bit.

- 1 = Power down and go into Stop mode
- 0 = Not in STOP mode

**SYSTEM STATUS REGISTER (SYSSTAT)**

Register Name and Address: SYSSTAT - \$0c

Bits	7	6	5	4	3	2	1	0
Read	HP_OCF	LINCL	HVDD_OCF	HS_OCF	LVF	HVF	HB_OCF	HTF
Write								
Reset	0	0	0	0	0	0	0	0

**Hall-Effect Sensor Input Pin Over-current Flag Bit (HP\_OCF)**

This read/write flag is set on an over-current condition at one of the Hall-effect sensor input pins. Clear HP\_OCF and enable the output by writing a Logic [1] to the HP\_OCF flag. Reset clears the HP\_OCF bit. Writing a Logic [0] to HP\_OCF has no effect.

- 1 = Over-current condition on Hall-effect sensor input pin has occurred
- 0 = No over-current condition on Hall-effect sensor input pin has occurred

**LIN Current Limitation Bit (LINCL)**

This read-only bit is set if the LIN transmitter operates in current limitation region. Due to excessive power dissipation in the transmitter, software is advised to turn the transmitter off immediately.

- 1 = Transmitter operating in current limitation region
- 0 = Transmitter not operating in current limitation region

**HVDD Output Over-current Flag Bit (HVDD\_OCF)**

This read/write flag is set on an over-current condition at the HVDD pin. Clear HVDD\_OCF and enable the output by writing a Logic [1] to the HVDD\_OCF Flag. Reset clears the

HVDD\_OCF bit. Writing a Logic [0] to HVDD\_OCF has no effect.

- 1 = Over-current condition on HVDD has occurred
- 0 = No over-current condition on HVDD has occurred

**High Side Over-current Flag Bit (HS\_OCF)**

This read/write flag is set on an over-current condition at the high side driver. Clear HS\_OCF and enable the high side driver by writing a Logic [1] to HS\_OCF. Reset clears the HS\_OCF bit. Writing a Logic [0] to HS\_OCF has no effect.

- 1 = Over-current condition on high side drivers has occurred
- 0 = No over-current condition on high side drivers has occurred

**Low Voltage Bit (LVF)**

This read only bit is a copy of the LVF bit in the Interrupt Flag Register.

- 1 = Low voltage condition has occurred
- 0 = No low voltage condition has occurred

**High Voltage Sensor Bit (HVF)**

This read-only bit is a copy of the HVF bit in the Interrupt Flag Register.

- 1 = High voltage condition has occurred
- 0 = No high voltage condition has occurred

**H-Bridge Over-current Flag Bit (HB\_OCF)**

This read / write flag is set on an over-current condition at the H-Bridges. Clear HB\_OCF and enable the H-Bridge driver by writing a Logic [1] to HB\_OCF. Reset clears the HB\_OCF bit. Writing a Logic [0] to HB\_OCF has no effect.

- 1 = Over-current condition on H-Bridges has occurred
- 0 = No over-current condition on H-Bridges has occurred

**Over-temperature Status Bit (HTF)**

This read-only bit is a copy of the HTF bit in the Interrupt Flag Register.

- 1 = Over-temperature condition has occurred
- 0 = No over-temperature condition has occurred

**AUTONOMOUS WATCHDOG (AWD)**

The Autonomous Watchdog module consists of three functions:

- Watchdog function for the CPU in RUN mode
- Periodic interrupt function in STOP mode
- Cyclic wake-up function in STOP mode

The AWD is enabled if AWDIE, AWDRE, or AWDCC in the AWDCTL Register is set. If these bits are cleared, the AWD oscillator is disabled and the watchdog switched off.

The watchdog function is only available in RUN mode. On setting the AWDRE bit, watchdog functionality in RUN mode

is activated. Once this function is enabled, it is not possible to disable it via software.

If the timer reaches end value and AWDRE is set, a system reset is initiated. Operations of the watchdog function cease in STOP mode. Normal operation will be continued when the system is back to RUN mode.

To prevent a watchdog reset, the watchdog timeout counter must be reset before it reaches the end value. This is done by a write to the AWRDST bit in the AWDCTL Register.

## PERIODIC INTERRUPT

Periodic interrupt is only available in STOP mode. It is enabled by setting the AWDIE bit in the AWDCTL Register. If AWDIE is set, the AWD wakes up the system after a fixed period of time. This time period can be selected with bit AWDR in the AWDCTL Register.

## CYCLIC WAKE-UP

The cyclic wake-up feature is only available in STOP mode. If this feature is enabled, the selected Hall-effect sensor input pins are switched on and sensed. If a "1" is detected on one of these inputs and the interrupt for the Hall-effect sensors is enabled, a system wake-up is performed. (Switch on main voltage regulator and assert  $\overline{\text{IRQ\_A}}$  to the microcontroller).

## AUTONOMOUS WATCHDOG CONTROL REGISTER (AWDCTL)

Register Name and Address: AWDCTL - \$0a

Bits	7	6	5	4	3	2	1	0
Read	0	0	0	AWDR E	AWDI E	AWDC C	AWDF	AWD R
Write			AWDRS T					
Reset	0	0	0	0	0	0	0	0

### Autonomous Watchdog Reset Bit (AWDRST)

This write-only bit resets the Autonomous Watchdog timeout period. AWRDST always reads 0. Reset clears AWRDST bit.

- 1 = Reset AWD and restart timeout period
- 0 = No effect

### Autonomous Watchdog Reset Enable Bit (AWDRE)

This read/write bit enables resets on AWD timeouts. A reset on the  $\overline{\text{RST\_A}}$  is only asserted when the device is in RUN mode. AWDRE is one time settable (write once) after each reset. Reset clears the AWDRE bit.

- 1 = Autonomous watchdog enabled
- 0 = Autonomous watchdog disabled

### Autonomous Watchdog Interrupt Enable Bit (AWDIE)

This read/write bit enables CPU interrupts by the Autonomous Watchdog timeout flag, AWDF.  $\overline{\text{IRQ\_A}}$  is only asserted when the device is in STOP mode. Reset clears the AWDIE bit.

- 1 = CPU interrupt requests from AWDF enabled
- 0 = CPU interrupt requests from AWDF disabled

### Autonomous Watchdog Cyclic Check (AWDCC)

This read/write bit enables the cyclic check of the two pin Hall-effect sensor and the analog inputs. Reset clears the AWDCC bit.

- 1 = Cyclic check of the Hall-effect sensor and analog port
- 0 = No cyclic check of the Hall-effect sensor and analog port

### Autonomous Watchdog Timeout Flag Bit (AWDF)

This read/write flag is set when the Autonomous Watchdog has timed out. Clear AWDF by writing a Logic [1] to AWDF. Clearing AWDF also resets the AWD counter and starts a new timeout period. Reset clears the AWDF bit. Writing a Logic [0] to AWDF has no effect.

- 1 = AWD has timed out
- 0 = AWD has not yet timed out

### Autonomous Watchdog Rate Bit (AWDR)

This read/write bit selects the clock rate of the Autonomous Watchdog. Reset clears the AWDR bit.

- 1 = Fast rate selected (10 ms)
- 0 = Slow rate selected (20 ms)

## VOLTAGE REGULATOR

The 908E625 chip contains a low power, low drop voltage regulator to provide internal power and external power for the MCU. The on-chip regulator consist of two elements, the main voltage regulator and the low voltage reset circuit.

The  $V_{DD}$  regulator accepts a unregulated input supply and provides a regulated  $V_{DD}$  supply to all digital sections of the device. The output of the regulator is also connected to the VDD pin to provide the 5.0 V to the microcontroller.

### RUN Mode

During RUN mode the main voltage regulator is on. It provides a regulated supply to all digital sections.

### STOP Mode

During STOP mode the STOP mode regulator supplies a regulated output voltage. The STOP mode regulator has a

very limited output current capability. The output voltage will be lower than the output voltage of the main voltage regulator.

## FACTORY TRIMMING AND CALIBRATION

To enhance the ease-of-use of the 908E625, various parameters (e.g. ICG trim value) are stored in the flash memory of the device. The following flash memory locations are reserved for this purpose and might have a value different from the *empty* (0xFF) state:

- 0xFD80:0xFDDF Trim and Calibration Values
- 0xFFFE:0xFFFF Reset Vector

In the event the application uses these parameters, one has to take care not to erase or override these values. If these parameters are not used, these flash locations can be erased and otherwise used.

### Trim Values

Below the usage of the trim values located in the flash memory is explained

### Internal Clock Generator (ICG) Trim Value

The internal clock generator (ICG) module is used to create a stable clock source for the microcontroller without using any external components. The untrimmed frequency of the low frequency base clock (IBASE), will vary as much as  $\pm 25$  percent due to process, temperature, and voltage dependencies. To compensate this dependencies a ICG trim values is located at address \$FDC2. After trimming the ICG is a range of typ.  $\pm 2\%$  ( $\pm 3\%$  max.) at nominal conditions (filtered (100 nF) and stabilized (4,7  $\mu$ F)  $V_{DD} = 5.0$  V,  $T_{AMBIENT} \sim 25$  °C) and will vary over temperature and voltage ( $V_{DD}$ ) as indicated in the 68HC908EY16 datasheet.

To trim the ICG this values has to be copied to the ICG Trim Register ICGTR at address \$38 of the MCU.

**Important** The value has to copied after every reset.

## TYPICAL APPLICATIONS

### DEVELOPMENT SUPPORT

As the 908E625 has the MC68HC908EY16 MCU embedded typically all the development tools available for the MCU also apply for this device, however due to the fact of the additional analog die circuitry and the nominal +12 V supply voltage some additional items have to be considered:

- nominal 12 V rather than 5.0 V or 3.0 V supply
- high voltage  $V_{TST}$  might be applied not only to IRQ pin, but IRQ\_A pin

For a detailed information on the MCU related development support see the MC68HC908EY16 datasheet - section development support.

The programming is principally possible at two stages in the manufacturing process - first on chip level, before the IC is soldered onto a pcb board and second after the IC is soldered onto the pcb board.

### Chip level programming

On Chip level the easiest way is to only power the MCU with +5.0 V (see [Figure 23](#)) and not to provide the analog chip with VSUP, in this setup all the analog pin should be left open (e.g. VSUP[1:3]) and interconnections between MCU and analog die have to be separated (e.g.  $\overline{IRQ} - \overline{IRQ\_A}$ ).

This mode is well described in the MC68HC908EY16 datasheet - section development support.

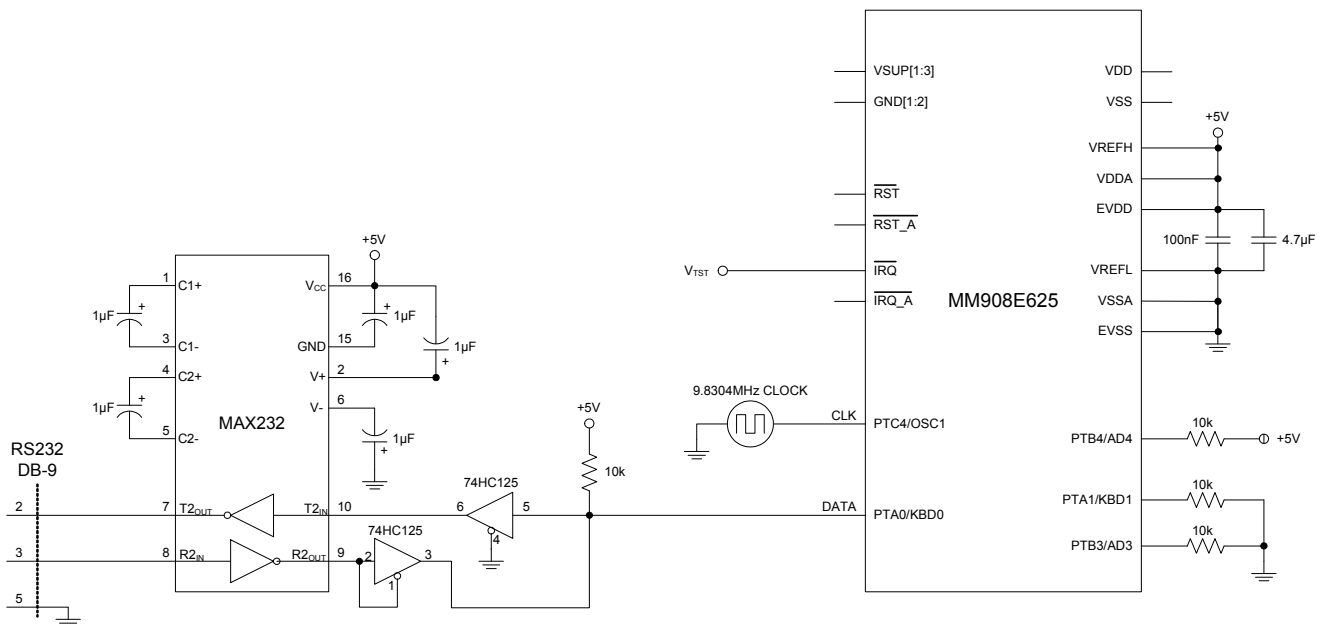

Figure 23. Normal Monitor Mode Circuit (MCU only)

Of course its also possible to supply the whole system with Vs<sub>up</sub> (12 V) instead as described in [Figure 24, page 40](#).

### PCB level programming

If the IC is soldered onto the pcb board its typically not possible to separately power the MCU with +5.0 V, the whole system has to be powered up providing  $V_{SUP}$  (see [Figure 24](#)).

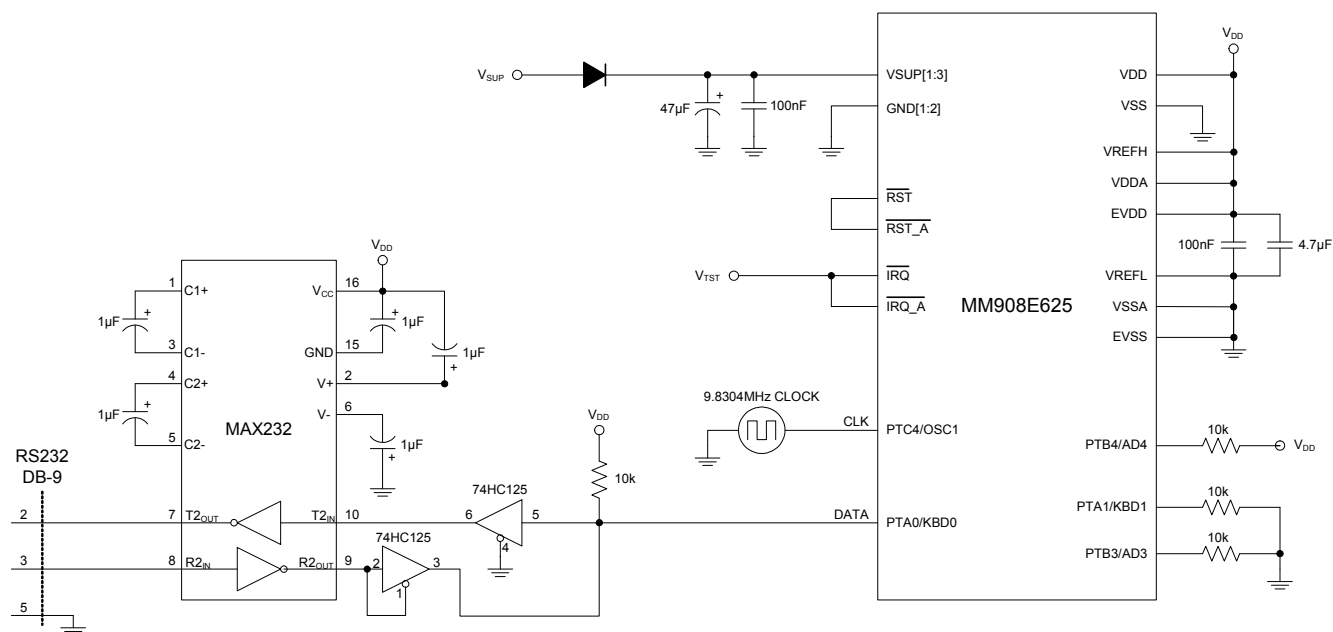

Figure 24. Normal Monitor Mode Circuit

Table 12 summarizes the possible configurations and the necessary setups.

Table 12. Monitor Mode Signal Requirements and Options

Mode	$\overline{\text{IRQ}}$	$\overline{\text{RST}}$	Reset Vector	Serial Communication		Mode Selection		ICG	COP	Normal Request Timeout	Communication Speed		
				PTA0	PTA1	PTB3	PTB4				External Clock	Bus Frequency	Baud Rate
Normal Monitor	$V_{TST}$	$V_{DD}$	X	1	0	0	1	OFF	disabled	disabled	9.8304 MHz	2.4576 MHz	9600
Forced Monitor	$V_{DD}$	$V_{DD}$	\$FFFF (blank)	1	0	X	X	OFF	disabled	disabled	9.8304 MHz	2.4576 MHz	9600
	GND	$V_{DD}$						ON	disabled	disabled	—	Nominal 1.6MHz	Nominal 6300
User	$V_{DD}$	$V_{DD}$	not \$FFFF (not blank)	X	X	X	X	ON	enabled	enabled	—	Nominal 1.6MHz	Nominal 6300

Notes

- PTA0 must have a pull-up resistor to  $V_{DD}$  in monitor mode
- External clock is a 4.9152 MHz, 9.8304 MHz or 19.6608 MHz canned oscillator on OCS1
- Communication speed with external clock is depending on external clock value. Baud rate is bus frequency / 256
- X = don't care
- $V_{TST}$  is a high voltage  $V_{DD} + 3.5 \text{ V} \leq V_{TST} \leq V_{DD} + 4.5 \text{ V}$

## EMC/EMI RECOMMENDATIONS

This paragraph gives some device specific recommendations to improve EMC/EMI performance. Further generic design recommendations can be e.g. found on the Freescale web site [www.freescale.com](http://www.freescale.com).

### VSUP pins (VSUP1:VSUP3)

Its recommended to place a high-quality ceramic decoupling capacitor close to the VSUP pins to improve EMC/EMI behavior.

### LIN pin

For DPI (Direct Power Injection) and ESD (Electro Static Discharge) its recommended to place a high quality ceramic decoupling capacitor near the LIN pin. An additional varistor will further increase the immunity against ESD. A ferrite in the LIN line will suppress some of the noise induced.

### Voltage regulator output pins (VDD and AGND)

Use a high quality ceramic decoupling capacitor to stabilize the regulated voltage.

### MCU digital supply pins (EVDD and EVSS)

Fast signal transitions on MCU pins place high, short-duration current demands on the power supply. To prevent noise problems, take special care to provide power supply bypassing at the MCU. It is recommended that a high quality ceramic decoupling capacitor be placed between these pins.

### MCU analog supply pins (VREFH, VDDA and VREFL, VSSA)

To avoid noise on the analog supply pins its important to take special care on the layout. The MCU digital and analog supplies should be tied to the same potential via separate traces and connected to the voltage regulator output.

[Figure 25](#) and [Figure 26](#) show the recommendations on schematics and layout level and [Table 13](#) indicates recommended external components and layout considerations.

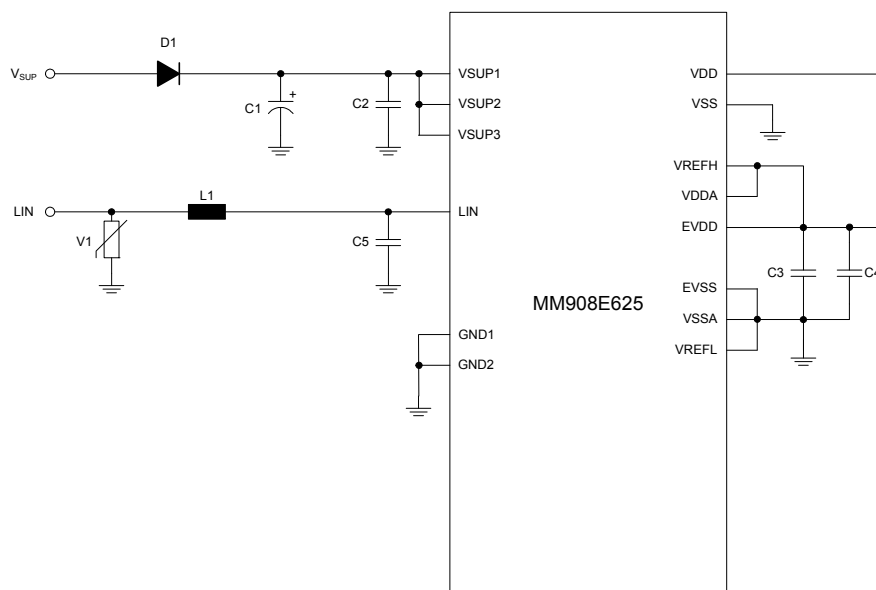

Figure 25. EMC/EMI Recommendations

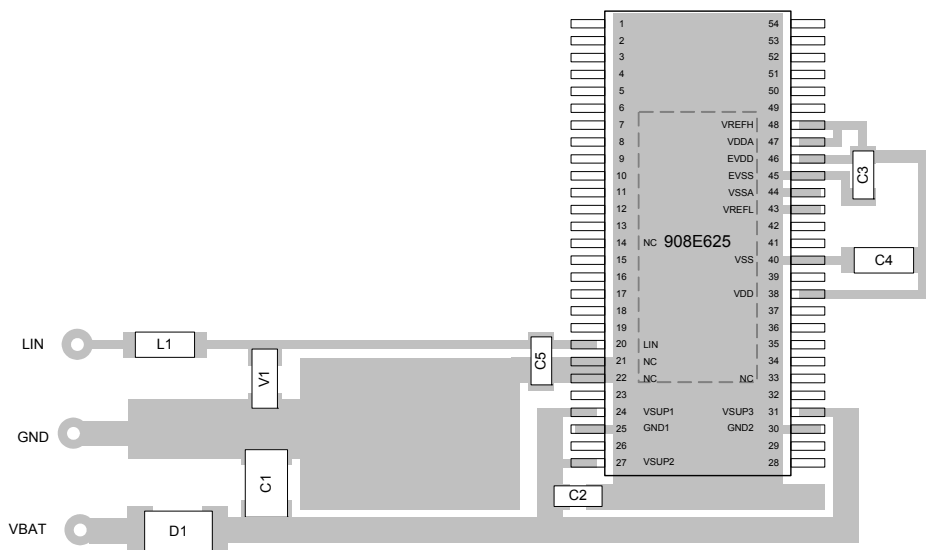

Figure 26. PCB Layout Recommendations

Table 13. Component Value Recommendation

Component	Recommended Value <sup>(1)</sup>	Comments / Signal routing
D1		reverse battery protection
C1	Bulk Capacitor	
C2	100nF, SMD Ceramic, Low ESR	Close (<5mm) to VSUP1, VSUP2 pins with good ground return
C3	100nF, SMD Ceramic, Low ESR	Close (<3mm) to digital supply pins (EVDD, EVSS) with good ground return. The positive analog (VREFH, VDDA) and the digital (EVDD) supply should be connected right at the C3.
C4	4,7uF, SMD Ceramic, Low ESR	Bulk Capacitor
C5	180pF, SMD Ceramic, Low ESR	Close (<5.0 mm) to LIN pin. Total Capacitance on LIN has to be below 220 pF. ( $C_{total} = C_{LIN-Pin} + C5 + C_{Varistor} \sim 10 \text{ pF} + 180 \text{ pF} + 15 \text{ pF}$ )
V1 <sup>(2)</sup>	Varistor Type TDK AVR-M1608C270MBAAB	Optional (close to LIN connector)
L1 <sup>(2)</sup>	SMD Ferrite Bead Type TDK MMZ2012Y202B	Optional, (close to LIN connector)

Notes

1. Freescale does not assume liability, endorse, or want components from external manufactures that are referenced in circuit drawings or tables. While Freescale offers component recommendations in this configuration, it is the customer's responsibility to validate their application.
2. Components are recommended to improve EMC and ESD performance.



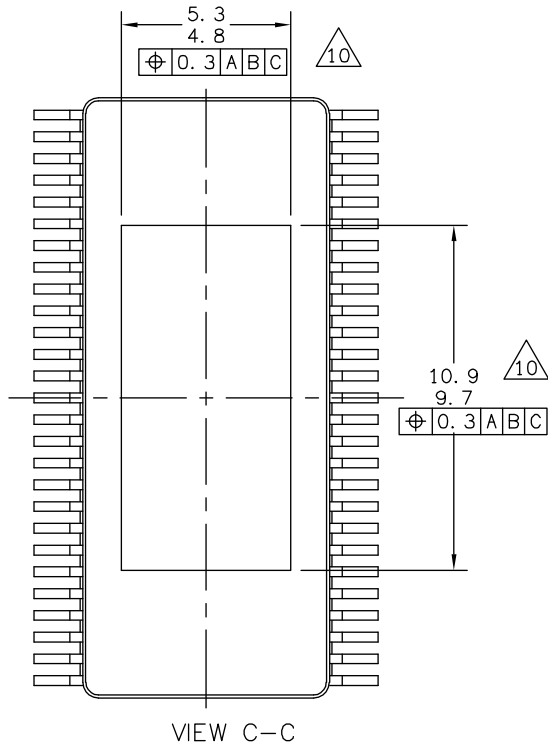
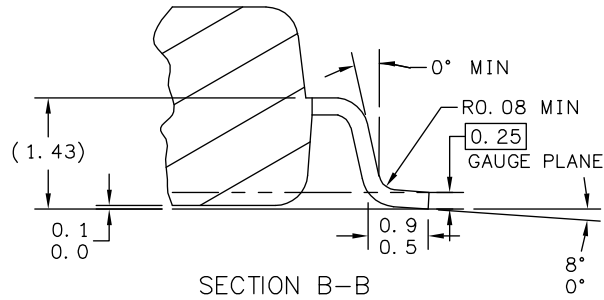

© FREESCALE SEMICONDUCTOR, INC. ALL RIGHTS RESERVED.	<b>MECHANICAL OUTLINE</b>	PRINT VERSION NOT TO SCALE	
TITLE: 54LD SOIC W/B, 0.65 PITCH 5.1 X 10.3 EXPOSED PAD, CASE-OUTLINE	DOCUMENT NO: 98ARL10519D	REV: D	
	CASE NUMBER: 1400-03	02 MAY 2008	
	STANDARD: NON-JEDEC		

EK SUFFIX (PB-FREE)  
54-PIN  
98ARL10519D  
ISSUE D

NOTES:

1. DIMENSIONS ARE IN MILLIMETERS.
2. DIMENSIONING AND TOLERANCING PER ASME Y14.5M-1994.
3. DATUMS B AND C TO BE DETERMINED AT THE PLANE WHERE THE BOTTOM OF THE LEADS EXIT THE PLASTIC BODY.
4. THIS DIMENSION DOES NOT INCLUDE MOLD FLASH, PROTRUSION OR GATE BURRS. MOLD FLASH, PROTRUSION OR GATE BURRS SHALL NOT EXCEED 0.15 MM PER SIDE. THIS DIMENSION IS DETERMINED AT THE PLANE WHERE THE BOTTOM OF THE LEADS EXIT THE PLASTIC BODY.
5. THIS DIMENSION DOES NOT INCLUDE INTER-LEAD FLASH OR PROTRUSIONS. INTER-LEAD FLASH AND PROTRUSIONS SHALL NOT EXCEED 0.25 MM PER SIDE. THIS DIMENSION IS DETERMINED AT THE PLANE WHERE THE BOTTOM OF THE LEADS EXIT THE PLASTIC BODY.
6. THIS DIMENSION DOES NOT INCLUDE DAMBAR PROTRUSION. ALLOWABLE DAMBAR PROTRUSION SHALL NOT CAUSE THE LEAD WIDTH TO EXCEED 0.46 mm. DAMBAR CANNOT BE LOCATED ON THE LOWER RADIUS OR THE FOOT. MINIMUM SPACE BETWEEN PROTRUSION AND ADJACENT LEAD SHALL NOT BE LESS THAN 0.07 mm.
7. EXACT SHAPE OF EACH CORNER IS OPTIONAL.
8. THESE DIMENSIONS APPLY TO THE FLAT SECTION OF THE LEAD BETWEEN 0.1 mm AND 0.3 mm FROM THE LEAD TIP.
9. THE PACKAGE TOP MAY BE SMALLER THAN THE PACKAGE BOTTOM. THIS DIMENSION IS DETERMINED AT THE OUTERMOST EXTREMES OF THE PLASTIC BODY EXCLUSIVE OF MOLD FLASH, TIE BAR BURRS, GATE BURRS AND INTER-LEAD FLASH, BUT INCLUDING ANY MISMATCH BETWEEN THE TOP AND BOTTOM OF THE PLASTIC BODY.
10. THESE DIMENSIONS RANGES DEFINE THE PRIMARY KEEP-OUT AREA. MOLD LOCKING AND RESIN BLEED CONTROL FEATURES MAY BE VISIBLE AND THEY MAY EXTEND TO 0.4mm FROM MAXIMUM EXPOSED PAD SIZE

© FREESCALE SEMICONDUCTOR, INC. ALL RIGHTS RESERVED.	<b>MECHANICAL OUTLINE</b>	PRINT VERSION NOT TO SCALE	
TITLE: 54LD SOIC W/B, 0.65 PITCH 5.1 X 10.3 EXPOSED PAD, CASE-OUTLINE	DOCUMENT NO: 98ARL10519D	REV: D	
	CASE NUMBER: 1400-03	02 MAY 2008	
	STANDARD: NON-JEDEC		

EK SUFFIX (PB-FREE)  
54-PIN  
98ARL10519D  
ISSUE D

# ADDITIONAL DOCUMENTATION

## THERMAL ADDENDUM (REV 2.0)

### Introduction

This thermal addendum is provided as a supplement to the MM908E625 technical data sheet. The addendum provides thermal performance information that may be critical in the design and development of system applications. All electrical, application and packaging information is provided in the data sheet.

### Package and Thermal Considerations

This MM908E625 is a dual die package. There are two heat sources in the package independently heating with  $P_1$  and  $P_2$ . This results in two junction temperatures,  $T_{J1}$  and  $T_{J2}$ , and a thermal resistance matrix with  $R_{\theta JA mn}$ .

For  $m = 1, n = 1$ ,  $R_{\theta JA 11}$  is the thermal resistance from Junction 1 to the reference temperature while only heat source 1 is heating with  $P_1$ .

For  $m = 1, n = 2$ ,  $R_{\theta JA 12}$  is the thermal resistance from Junction 1 to the reference temperature while heat source 2 is heating with  $P_2$ . This applies to  $R_{\theta J21}$  and  $R_{\theta J22}$ , respectively.

$$\begin{Bmatrix} T_{J1} \\ T_{J2} \end{Bmatrix} = \begin{bmatrix} R_{\theta JA 11} & R_{\theta JA 12} \\ R_{\theta JA 21} & R_{\theta JA 22} \end{bmatrix} \cdot \begin{Bmatrix} P_1 \\ P_2 \end{Bmatrix}$$

The stated values are solely for a thermal performance comparison of one package to another in a standardized environment. This methodology is not meant to and will not predict the performance of a package in an application-specific environment. Stated values were obtained by measurement and simulation according to the standards listed below.

### Standards

**Table 1. Thermal Performance Comparison**

Thermal Resistance	1 = Power Chip, 2 = Logic Chip [ $^{\circ}\text{C}/\text{W}$ ]		
	$m = 1, n = 1$	$m = 1, n = 2$ $m = 2, n = 1$	$m = 2, n = 2$
$R_{\theta JA mn}^{(1)(2)}$	23	20	24
$R_{\theta JB mn}^{(2)(3)}$	9.0	6.0	10
$R_{\theta JA mn}^{(1)(4)}$	52	47	52
$R_{\theta JC mn}^{(5)}$	1.0	0	2.0

Notes:

- Per JEDEC JESD51-2 at natural convection, still air condition.
- 2s2p thermal test board per JEDEC JESD51-7 and JESD51-5.
- Per JEDEC JESD51-8, with the board temperature on the center trace near the power outputs.
- Single layer thermal test board per JEDEC JESD51-3 and JESD51-5.
- Thermal resistance between the die junction and the exposed pad, "infinite" heat sink attached to exposed pad.

908E625

---

54-PIN  
SOICW-EP

---

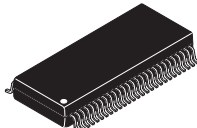

EK SUFFIX (Pb-Free)  
98ARL10519D  
54-PIN SOICW-EP

**Note** For package dimensions, refer to 98ARL10519D.

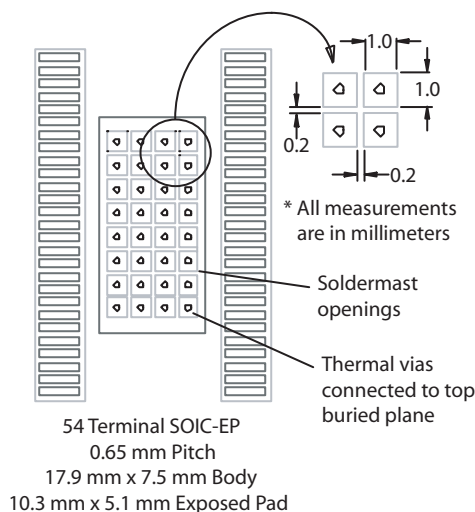

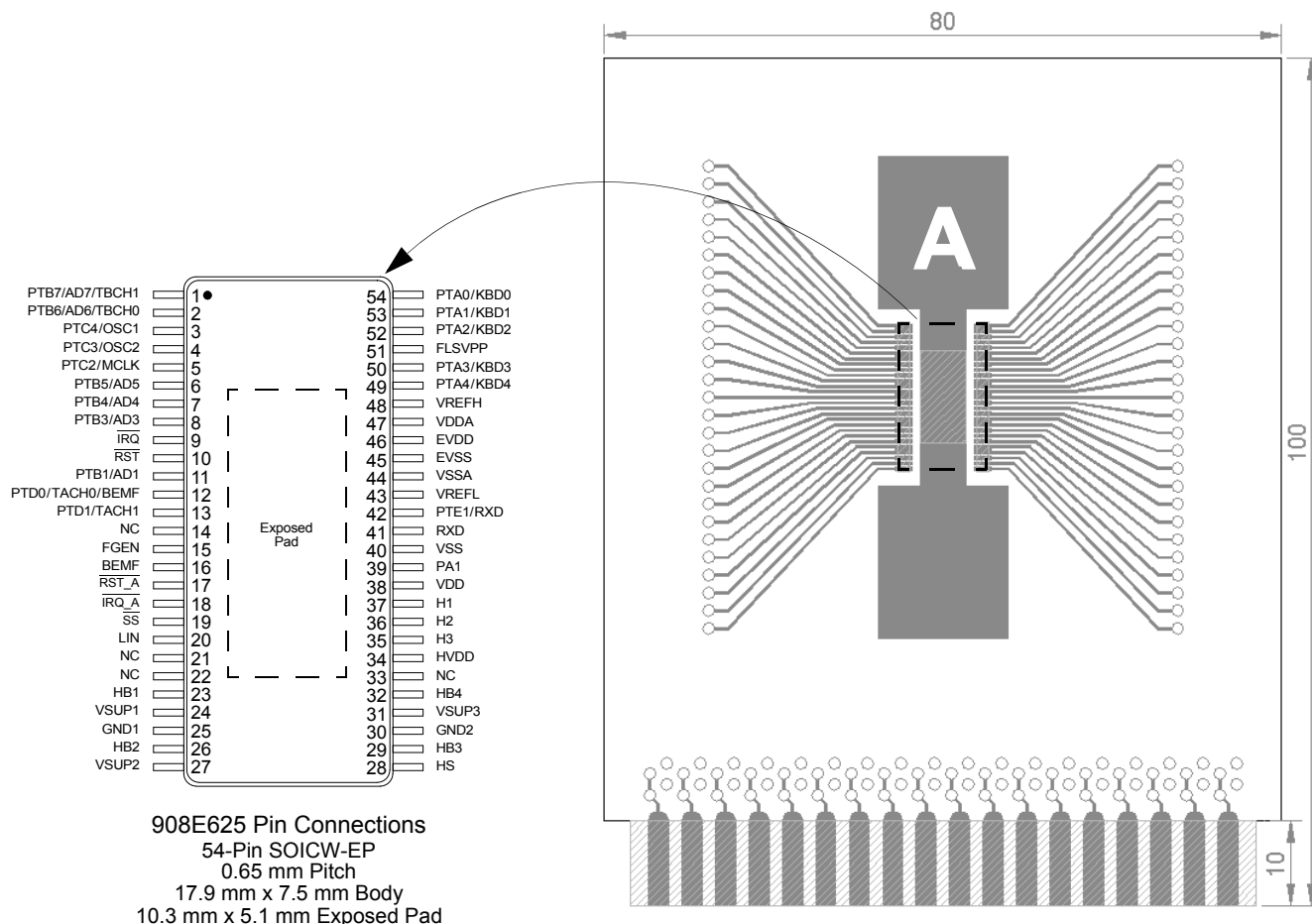

Figure 27. Thermal Test Board

**Device on Thermal Test Board**

- Material: Single layer printed circuit board  
 FR4, 1.6 mm thickness  
 Cu traces, 0.07 mm thickness
- Outline: 80 mm x 100 mm board area,  
 including edge connector for thermal testing
- Area A: Cu heat-spreading areas on board surface
- Ambient Conditions: Natural convection, still air

**Table 14. Thermal Resistance Performance**

Thermal Resistance	Area A (mm <sup>2</sup> )	1 = Power Chip, 2 = Logic Chip (°C/W)		
		<i>m</i> = 1, <i>n</i> = 1	<i>m</i> = 1, <i>n</i> = 2 <i>m</i> = 2, <i>n</i> = 1	<i>m</i> = 2, <i>n</i> = 2
$R_{\theta JA mn}$	0	53	48	53
	300	39	34	38
	600	35	30	34
$R_{\theta JS mn}$	0	21	16	20
	300	15	11	15
	600	14	9.0	13

$R_{\theta JA}$  is the thermal resistance between die junction and ambient air.

$R_{\theta JS mn}$  is the thermal resistance between die junction and the reference location on the board surface near a center lead of the package.

This device is a dual die package. Index *m* indicates the die that is heated. Index *n* refers to the number of the die where the junction temperature is sensed.

## REVISION HISTORY

REVISION	DATE	DESCRIPTION OF CHANGES
7.0	9/2010	<ul style="list-style-type: none"> <li>• Implemented Revision History page</li> <li>• Changed <a href="#">Peak Package Reflow Temperature During Reflow<sup>(7)(8)</sup></a> description.</li> <li>• Added note <sup>(8)</sup></li> </ul>
8.0	7/2011	<ul style="list-style-type: none"> <li>• Changes to <a href="#">AWD Period Low = 512 tOSC</a> and <a href="#">AWD Period High = 256 tOSC</a></li> <li>• Change to <a href="#">LIN Timing Description</a></li> <li>• Change to <a href="#">Stop Mode Output Voltage (Maximum Output Current 100 μA)</a></li> <li>• Added MM908E625ACEK and MM908E625ACPEK to the ordering information</li> <li>• Removed part numbers with DWB suffix</li> <li>• Updated Freescale form and style</li> <li>• Updated packaging information</li> </ul>
9.0	10/2011	<ul style="list-style-type: none"> <li>• Change to <a href="#">LIN Timing Description</a></li> </ul>
10.0	04/2012	<ul style="list-style-type: none"> <li>• Removed part number MM908E625ACEK.</li> <li>• Updated Freescale form and style</li> </ul>

**How to Reach Us:****Home Page:**

freescale.com

**Web Support:**

freescale.com/support

Information in this document is provided solely to enable system and software implementers to use Freescale products. There are no express or implied copyright licenses granted hereunder to design or fabricate any integrated circuits on the information in this document.

Freescale reserves the right to make changes without further notice to any products herein. Freescale makes no warranty, representation, or guarantee regarding the suitability of its products for any particular purpose, nor does Freescale assume any liability arising out of the application or use of any product or circuit, and specifically disclaims any and all liability, including without limitation consequential or incidental damages. "Typical" parameters that may be provided in Freescale data sheets and/or specifications can and do vary in different applications, and actual performance may vary over time. All operating parameters, including "typicals," must be validated for each customer application by customer's technical experts. Freescale does not convey any license under its patent rights nor the rights of others. Freescale sells products pursuant to standard terms and conditions of sale, which can be found at the following address: <http://www.reg.net/v2/webservices/Freescale/Docs/TermsandConditions.htm>

Freescale, the Freescale logo, AltiVec, C-5, CodeTest, CodeWarrior, ColdFire, C-Ware, Energy Efficient Solutions logo, mobileGT, PowerQUICC, QorIQ, Qorivva, StarCore, and Symphony are trademarks of Freescale Semiconductor, Inc., Reg. U.S. Pat. & Tm. Off. Airfast, BeeKit, BeeStack, ColdFire+, CoreNet, Flexis, MagniV, MXC, Platform in a Package, Processor expert, QorIQ Qonverge, QUICC Engine, Ready Play, SMARTMOS, TurboLink, Vybrid, and Xtrinsic are trademarks of Freescale Semiconductor, Inc. All other product or service names are the property of their respective owners.

© 2012 Freescale Semiconductor, Inc.



Document Number: MM908E625

Rev 10

04/2012

## Looking for pricing, stock, or lifecycle information?

Click below to explore more details on WIN SOURCE:

-  [View MM908E625ACPEK on WIN SOURCE](#)
-  [Rochester Electronics Information](#)

## Optimize Your Supply Chain with WIN SOURCE Solutions

-  Global Sourcing Solution
-  Obsolete Management
-  Cost Control Management
-  Shortage Management
-  Alternative Solution
-  Excess Inventory Management