



**THE DATASHEET OF  
MKL34Z64VLH4**



## Kinetis KL34 Sub-Family

### 48 MHz Cortex-M0+ Based Microcontroller

Designed with efficiency in mind. Compatible with all other Kinetis L families as well as Kinetis K3x family. General purpose MCU with segment LCD, featuring market leading ultra low-power to provide developers an appropriate entry-level 32-bit solution.

This product offers:

- Run power consumption down to 50  $\mu$ A/MHz in very low power run mode
- Static power consumption down to 2  $\mu$ A with full state retention and 4.5  $\mu$ s wakeup
- Ultra-efficient Cortex-M0+ processor running up to 48 MHz with industry leading throughput
- Memory option is up to 64 KB flash and 8 KB RAM
- Energy-saving architecture is optimized for low power with 90 nm TFS technology, clock and power gating techniques, and zero wait state flash memory controller

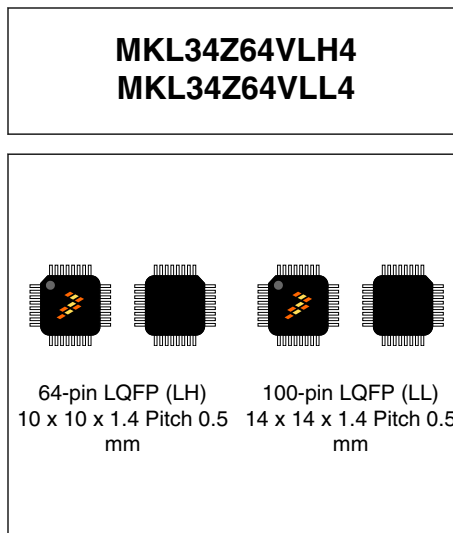

#### Performance

- 48 MHz ARM<sup>®</sup> Cortex<sup>®</sup>-M0+ core

#### Memories and memory interfaces

- Up to 64 KB program flash memory
- Up to 8 KB SRAM

#### System peripherals

- Nine low-power modes to provide power optimization based on application requirements
- COP Software watchdog
- 4-channel DMA controller, supporting up to 63 request sources
- Low-leakage wakeup unit
- SWD debug interface and Micro Trace Buffer
- Bit Manipulation Engine

#### Clocks

- 32 kHz to 40 kHz or 3 MHz to 32 MHz crystal oscillator
- Multi-purpose clock source

#### Operating Characteristics

- Voltage range: 1.71 to 3.6 V
- Flash write voltage range: 1.71 to 3.6 V
- Temperature range (ambient): -40 to 105°C

#### Human-machine interface

- Segment LCD controller supporting up to 47 frontplanes and 8 backplanes, or 51 frontplanes and 4 backplanes
- Up to 84 general-purpose input/output (GPIO)

#### Communication interfaces

- Two 16-bit SPI modules
- One low power UART module
- Two UART modules
- Two I2C module

#### Analog Modules

- 12-bit SAR ADC
- Analog comparator (CMP) containing a 6-bit DAC and programmable reference input

#### Timers

- Six channel Timer/PWM (TPM)
- Two 2-channel Timer/PWM modules
- Periodic interrupt timers
- 16-bit low-power timer (LPTMR)
- Real time clock

#### Security and integrity modules

- 80-bit unique identification number per chip

### Ordering Information <sup>1</sup>

Part Number	Memory		Maximum number of I/O's
	Flash (KB)	SRAM (KB)	
MKL34Z64VLH4	64	8	54
MKL34Z64VLL4	64	8	84

1. To confirm current availability of orderable part numbers, go to <http://www.freescale.com> and perform a part number search.

### Related Resources

Type	Description	Resource
Selector Guide	The Freescale Solution Advisor is a web-based tool that features interactive application wizards and a dynamic product selector.	<a href="#">Solution Advisor</a>
Reference Manual	The Reference Manual contains a comprehensive description of the structure and function (operation) of a device.	KL34P100M48SF4RM <sup>1</sup>
Data Sheet	The Data Sheet includes electrical characteristics and signal connections.	KL34P100M48SF4 <sup>1</sup>
Chip Errata	The chip mask set Errata provides additional or corrective information for a particular device mask set.	KINETIS_L_xN40H <sup>2</sup>
Package drawing	Package dimensions are provided in package drawings.	LQFP 64-pin: 98ASS23234W <sup>1</sup> LQFP 100-pin: 98ASS23308W <sup>1</sup>

1. To find the associated resource, go to <http://www.freescale.com> and perform a search using this term.
2. To find the associated resource, go to <http://www.freescale.com> and perform a search using this term with the “x” replaced by the revision of the device you are using.



# Table of Contents

1 Ratings.....	4	3.6.1 ADC electrical specifications.....	26
1.1 Thermal handling ratings.....	4	3.6.2 CMP and 6-bit DAC electrical specifications.....	29
1.2 Moisture handling ratings.....	4	3.7 Timers.....	31
1.3 ESD handling ratings.....	4	3.8 Communication interfaces.....	31
1.4 Voltage and current operating ratings.....	4	3.8.1 SPI switching specifications.....	31
2 General.....	5	3.8.2 Inter-Integrated Circuit Interface (I2C) timing.....	35
2.1 AC electrical characteristics.....	5	3.8.3 UART.....	37
2.2 Nonswitching electrical specifications.....	5	3.9 Human-machine interfaces (HMI).....	37
2.2.1 Voltage and current operating requirements.....	6	3.9.1 LCD electrical characteristics.....	37
2.2.2 LVD and POR operating requirements.....	6	4 Dimensions.....	38
2.2.3 Voltage and current operating behaviors.....	7	4.1 Obtaining package dimensions.....	38
2.2.4 Power mode transition operating behaviors.....	8	5 Pinout.....	39
2.2.5 Power consumption operating behaviors.....	9	5.1 KL34 Signal Multiplexing and Pin Assignments.....	39
2.2.6 EMC radiated emissions operating behaviors...	15	5.2 KL34 pinouts.....	42
2.2.7 Designing with radiated emissions in mind.....	16	6 Ordering parts.....	44
2.2.8 Capacitance attributes.....	16	6.1 Determining valid orderable parts.....	44
2.3 Switching specifications.....	16	7 Part identification.....	45
2.3.1 Device clock specifications.....	16	7.1 Description.....	45
2.3.2 General switching specifications.....	17	7.2 Format.....	45
2.4 Thermal specifications.....	17	7.3 Fields.....	45
2.4.1 Thermal operating requirements.....	17	7.4 Example.....	45
2.4.2 Thermal attributes.....	17	8 Terminology and guidelines.....	46
3 Peripheral operating requirements and behaviors.....	18	8.1 Definition: Operating requirement.....	46
3.1 Core modules.....	18	8.2 Definition: Operating behavior.....	46
3.1.1 SWD electricals .....	18	8.3 Definition: Attribute.....	46
3.2 System modules.....	19	8.4 Definition: Rating.....	47
3.3 Clock modules.....	20	8.5 Result of exceeding a rating.....	47
3.3.1 MCG specifications.....	20	8.6 Relationship between ratings and operating requirements.....	48
3.3.2 Oscillator electrical specifications.....	22	8.7 Guidelines for ratings and operating requirements.....	48
3.4 Memories and memory interfaces.....	24	8.8 Definition: Typical value.....	48
3.4.1 Flash electrical specifications.....	24	8.9 Typical value conditions.....	49
3.5 Security and integrity modules.....	25	9 Revision history.....	50
3.6 Analog.....	25		

# 1 Ratings

## 1.1 Thermal handling ratings

**Table 1. Thermal handling ratings**

Symbol	Description	Min.	Max.	Unit	Notes
T <sub>STG</sub>	Storage temperature	-55	150	°C	1
T <sub>SDR</sub>	Solder temperature, lead-free	—	260	°C	2

1. Determined according to JEDEC Standard JESD22-A103, *High Temperature Storage Life*.
2. Determined according to IPC/JEDEC Standard J-STD-020, *Moisture/Reflow Sensitivity Classification for Nonhermetic Solid State Surface Mount Devices*.

## 1.2 Moisture handling ratings

**Table 2. Moisture handling ratings**

Symbol	Description	Min.	Max.	Unit	Notes
MSL	Moisture sensitivity level	—	3	—	1

1. Determined according to IPC/JEDEC Standard J-STD-020, *Moisture/Reflow Sensitivity Classification for Nonhermetic Solid State Surface Mount Devices*.

## 1.3 ESD handling ratings

**Table 3. ESD handling ratings**

Symbol	Description	Min.	Max.	Unit	Notes
V <sub>HBM</sub>	Electrostatic discharge voltage, human body model	-2000	+2000	V	1
V <sub>CDM</sub>	Electrostatic discharge voltage, charged-device model	-500	+500	V	2
I <sub>LAT</sub>	Latch-up current at ambient temperature of 105 °C	-100	+100	mA	3

1. Determined according to JEDEC Standard JESD22-A114, *Electrostatic Discharge (ESD) Sensitivity Testing Human Body Model (HBM)*.
2. Determined according to JEDEC Standard JESD22-C101, *Field-Induced Charged-Device Model Test Method for Electrostatic-Discharge-Withstand Thresholds of Microelectronic Components*.
3. Determined according to JEDEC Standard JESD78, *IC Latch-Up Test*.

## 1.4 Voltage and current operating ratings

**Table 4. Voltage and current operating ratings**

Symbol	Description	Min.	Max.	Unit
$V_{DD}$	Digital supply voltage	-0.3	3.8	V
$I_{DD}$	Digital supply current	—	120	mA
$V_{IO}$	IO pin input voltage	-0.3	$V_{DD} + 0.3$	V
$I_D$	Instantaneous maximum current single pin limit (applies to all port pins)	-25	25	mA
$V_{DDA}$	Analog supply voltage	$V_{DD} - 0.3$	$V_{DD} + 0.3$	V

## 2 General

### 2.1 AC electrical characteristics

Unless otherwise specified, propagation delays are measured from the 50% to the 50% point, and rise and fall times are measured at the 20% and 80% points, as shown in the following figure.

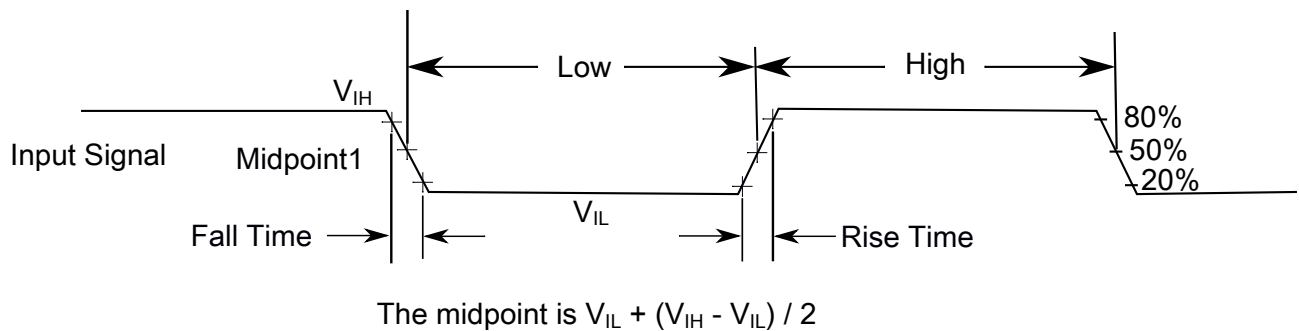

**Figure 2. Input signal measurement reference**

All digital I/O switching characteristics, unless otherwise specified, assume the output pins have the following characteristics.

- $C_L=30$  pF loads
- Slew rate disabled
- Normal drive strength

### 2.2 Nonswitching electrical specifications

## 2.2.1 Voltage and current operating requirements

**Table 5. Voltage and current operating requirements**

Symbol	Description	Min.	Max.	Unit	Notes
V <sub>DD</sub>	Supply voltage	1.71	3.6	V	
V <sub>DDA</sub>	Analog supply voltage	1.71	3.6	V	
V <sub>DD</sub> – V <sub>DDA</sub>	V <sub>DD</sub> -to-V <sub>DDA</sub> differential voltage	-0.1	0.1	V	
V <sub>SS</sub> – V <sub>SSA</sub>	V <sub>SS</sub> -to-V <sub>SSA</sub> differential voltage	-0.1	0.1	V	
V <sub>IH</sub>	Input high voltage <ul style="list-style-type: none"> <li>• 2.7 V ≤ V<sub>DD</sub> ≤ 3.6 V</li> <li>• 1.7 V ≤ V<sub>DD</sub> ≤ 2.7 V</li> </ul>	0.7 × V <sub>DD</sub> 0.75 × V <sub>DD</sub>	— —	V V	
V <sub>IL</sub>	Input low voltage <ul style="list-style-type: none"> <li>• 2.7 V ≤ V<sub>DD</sub> ≤ 3.6 V</li> <li>• 1.7 V ≤ V<sub>DD</sub> ≤ 2.7 V</li> </ul>	— —	0.35 × V <sub>DD</sub> 0.3 × V <sub>DD</sub>	V V	
V <sub>HYS</sub>	Input hysteresis	0.06 × V <sub>DD</sub>	—	V	
I <sub>ICIO</sub>	IO pin negative DC injection current — single pin <ul style="list-style-type: none"> <li>• V<sub>IN</sub> &lt; V<sub>SS</sub>-0.3V</li> </ul>	-3	—	mA	1
I <sub>ICcont</sub>	Contiguous pin DC injection current —regional limit, includes sum of negative injection currents of 16 contiguous pins <ul style="list-style-type: none"> <li>• Negative current injection</li> </ul>	-25	—	mA	
V <sub>ODPU</sub>	Open drain pullup voltage level	V <sub>DD</sub>	V <sub>DD</sub>	V	2
V <sub>RAM</sub>	V <sub>DD</sub> voltage required to retain RAM	1.2	—	V	

1. All I/O pins are internally clamped to V<sub>SS</sub> through a ESD protection diode. There is no diode connection to V<sub>DD</sub>. If V<sub>IN</sub> greater than V<sub>IO\_MIN</sub> (= V<sub>SS</sub>-0.3 V) is observed, then there is no need to provide current limiting resistors at the pads. If this limit cannot be observed then a current limiting resistor is required. The negative DC injection current limiting resistor is calculated as R = (V<sub>IO\_MIN</sub> - V<sub>IN</sub>)/|I<sub>ICIO</sub>|.
2. Open drain outputs must be pulled to V<sub>DD</sub>.

## 2.2.2 LVD and POR operating requirements

**Table 6. V<sub>DD</sub> supply LVD and POR operating requirements**

Symbol	Description	Min.	Typ.	Max.	Unit	Notes
V <sub>POR</sub>	Falling V <sub>DD</sub> POR detect voltage	0.8	1.1	1.5	V	—
V <sub>LVDH</sub>	Falling low-voltage detect threshold — high range (LVDV = 01)	2.48	2.56	2.64	V	—
	Low-voltage warning thresholds — high range					1

Table continues on the next page...

**Table 6. V<sub>DD</sub> supply LVD and POR operating requirements (continued)**

Symbol	Description	Min.	Typ.	Max.	Unit	Notes
V <sub>LW1H</sub>	<ul style="list-style-type: none"> <li>Level 1 falling (LVWV = 00)</li> </ul>	2.62	2.70	2.78	V	
V <sub>LW2H</sub>	<ul style="list-style-type: none"> <li>Level 2 falling (LVWV = 01)</li> </ul>	2.72	2.80	2.88	V	
V <sub>LW3H</sub>	<ul style="list-style-type: none"> <li>Level 3 falling (LVWV = 10)</li> </ul>	2.82	2.90	2.98	V	
V <sub>LW4H</sub>	<ul style="list-style-type: none"> <li>Level 4 falling (LVWV = 11)</li> </ul>	2.92	3.00	3.08	V	
V <sub>HYSH</sub>	Low-voltage inhibit reset/recover hysteresis — high range	—	±60	—	mV	—
V <sub>LVDL</sub>	Falling low-voltage detect threshold — low range (LVDV=00)	1.54	1.60	1.66	V	—
V <sub>LW1L</sub>	Low-voltage warning thresholds — low range <ul style="list-style-type: none"> <li>Level 1 falling (LVWV = 00)</li> </ul>	1.74	1.80	1.86	V	1
V <sub>LW2L</sub>	<ul style="list-style-type: none"> <li>Level 2 falling (LVWV = 01)</li> </ul>	1.84	1.90	1.96	V	
V <sub>LW3L</sub>	<ul style="list-style-type: none"> <li>Level 3 falling (LVWV = 10)</li> </ul>	1.94	2.00	2.06	V	
V <sub>LW4L</sub>	<ul style="list-style-type: none"> <li>Level 4 falling (LVWV = 11)</li> </ul>	2.04	2.10	2.16	V	
V <sub>HYSL</sub>	Low-voltage inhibit reset/recover hysteresis — low range	—	±40	—	mV	—
V <sub>BG</sub>	Bandgap voltage reference	0.97	1.00	1.03	V	—
t <sub>LPO</sub>	Internal low power oscillator period — factory trimmed	900	1000	1100	µs	—

1. Rising thresholds are falling threshold + hysteresis voltage

## 2.2.3 Voltage and current operating behaviors

**Table 7. Voltage and current operating behaviors**

Symbol	Description	Min.	Max.	Unit	Notes
V <sub>OH</sub>	Output high voltage — Normal drive pad (except RESET_b) <ul style="list-style-type: none"> <li>2.7 V ≤ V<sub>DD</sub> ≤ 3.6 V, I<sub>OH</sub> = -5 mA</li> <li>1.71 V ≤ V<sub>DD</sub> ≤ 2.7 V, I<sub>OH</sub> = -2.5 mA</li> </ul>	V <sub>DD</sub> - 0.5 V <sub>DD</sub> - 0.5	— —	V V	1, 2
V <sub>OH</sub>	Output high voltage — High drive pad (except RESET_b) <ul style="list-style-type: none"> <li>2.7 V ≤ V<sub>DD</sub> ≤ 3.6 V, I<sub>OH</sub> = -20 mA</li> <li>1.71 V ≤ V<sub>DD</sub> ≤ 2.7 V, I<sub>OH</sub> = -10 mA</li> </ul>	V <sub>DD</sub> - 0.5 V <sub>DD</sub> - 0.5	— —	V V	1, 2
I <sub>OHT</sub>	Output high current total for all ports	—	100	mA	
V <sub>OL</sub>	Output low voltage — Normal drive pad <ul style="list-style-type: none"> <li>2.7 V ≤ V<sub>DD</sub> ≤ 3.6 V, I<sub>OL</sub> = 5 mA</li> <li>1.71 V ≤ V<sub>DD</sub> ≤ 2.7 V, I<sub>OL</sub> = 2.5 mA</li> </ul>	— —	0.5 0.5	V V	1

Table continues on the next page...

**Table 7. Voltage and current operating behaviors (continued)**

Symbol	Description	Min.	Max.	Unit	Notes
V <sub>OL</sub>	Output low voltage — High drive pad <ul style="list-style-type: none"> <li>• 2.7 V ≤ V<sub>DD</sub> ≤ 3.6 V, I<sub>OL</sub> = 20 mA</li> <li>• 1.71 V ≤ V<sub>DD</sub> ≤ 2.7 V, I<sub>OL</sub> = 10 mA</li> </ul>	—	0.5	V	1
		—	0.5	V	
I <sub>OLT</sub>	Output low current total for all ports	—	100	mA	
I <sub>IN</sub>	Input leakage current (per pin) for full temperature range	—	1	μA	3
I <sub>IN</sub>	Input leakage current (per pin) at 25 °C	—	0.025	μA	3
I <sub>IN</sub>	Input leakage current (total all pins) for full temperature range	—		μA	3
I <sub>OZ</sub>	Hi-Z (off-state) leakage current (per pin)	—	1	μA	
R <sub>PU</sub>	Internal pullup resistors	20	50	kΩ	4

1. PTB0, PTB1, PTD6, and PTD7 I/O have both high drive and normal drive capability selected by the associated PTx\_PCRn[DSE] control bit. All other GPIOs are normal drive only.
2. The reset pin only contains an active pull down device when configured as the RESET signal or as a GPIO. When configured as a GPIO output, it acts as a pseudo open drain output.
3. Measured at V<sub>DD</sub> = 3.6 V
4. Measured at V<sub>DD</sub> supply voltage = V<sub>DD</sub> min and V<sub>input</sub> = V<sub>SS</sub>

## 2.2.4 Power mode transition operating behaviors

All specifications except t<sub>POR</sub> and VLLS<sub>x</sub>→RUN recovery times in the following table assume this clock configuration:

- CPU and system clocks = 48 MHz
- Bus and flash clock = 24 MHz
- FEI clock mode

POR and VLLS<sub>x</sub>→RUN recovery use FEI clock mode at the default CPU and system frequency of 21 MHz, and a bus and flash clock frequency of 10.5 MHz.

**Table 8. Power mode transition operating behaviors**

Symbol	Description	Min.	Typ.	Max.	Unit	Notes
t <sub>POR</sub>	After a POR event, amount of time from the point V <sub>DD</sub> reaches 1.8 V to execution of the first instruction across the operating temperature range of the chip. <ul style="list-style-type: none"> <li>• VLLS0 → RUN</li> </ul>	—	—	300	μs	1
		—	113	124	μs	

Table continues on the next page...

**Table 8. Power mode transition operating behaviors (continued)**

Symbol	Description	Min.	Typ.	Max.	Unit	Notes
	• VLLS1 → RUN	—	112	124	μs	
	• VLLS3 → RUN	—	53	60	μs	
	• LLS → RUN	—	4.5	5.0	μs	
	• VLPS → RUN	—	4.5	5.0	μs	
	• STOP → RUN	—	4.5	5.0	μs	

1. Normal boot (FTFA\_FOPT[LPBOOT]=11).

## 2.2.5 Power consumption operating behaviors

The maximum values stated in the following table represent characterized results equivalent to the mean plus three times the standard deviation (mean + 3 sigma).

**Table 9. Power consumption operating behaviors**

Symbol	Description	Typ.	Max	Unit	Note	
I <sub>DDA</sub>	Analog supply current	—	See note	mA	1	
I <sub>DD_RUNCO_CM</sub>	Run mode current in compute operation - 48 MHz core / 24 MHz flash/ bus disabled, LPTMR running using 4 MHz internal reference clock, CoreMark® benchmark code executing from flash, at 3.0 V	—	6.7	mA	2	
I <sub>DD_RUNCO</sub>	Run mode current in compute operation - 48 MHz core / 24 MHz flash / bus clock disabled, code of while(1) loop executing from flash, at 3.0 V	—	4.5	5.1	mA	3
I <sub>DD_RUN</sub>	Run mode current - 48 MHz core / 24 MHz bus and flash, all peripheral clocks disabled, code executing from flash	at 1.8 V	5.6	6.3	mA	3
		at 3.0 V	5.4	6.0	mA	
I <sub>DD_RUN</sub>	Run mode current - 48 MHz core / 24 MHz bus and flash, all peripheral clocks enabled, code executing from flash, at 1.8 V	—	6.9	7.3	mA	3, 4
		at 25 °C	6.9	7.1	mA	
		at 125 °C	7.3	7.6	mA	

Table continues on the next page...

**Table 9. Power consumption operating behaviors (continued)**

Symbol	Description		Typ.	Max	Unit	Note
I <sub>DD_WAIT</sub>	Wait mode current - core disabled / 48 MHz system / 24 MHz bus / flash disabled (flash doze enabled), all peripheral clocks disabled, at 3.0 V	—	2.9	3.5	mA	3
I <sub>DD_WAIT</sub>	Wait mode current - core disabled / 24 MHz system / 24 MHz bus / flash disabled (flash doze enabled), wait mode reduced frequency current at 3.0 V — all peripheral clocks disabled	—	2.2	2.8	mA	3
I <sub>DD_PSTOP2</sub>	Stop mode current with partial stop 2 clocking option - core and system disabled / 10.5 MHz bus, at 3.0 V	—	1.6	2.1	mA	3
I <sub>DD_VLPRCO_CM</sub>	Very-low-power run mode current in compute operation - 4 MHz core / 0.8 MHz flash / bus clock disabled, LPTMR running with 4 MHz internal reference clock, CoreMark benchmark code executing from flash, at 3.0 V	—	798	—	μA	5
I <sub>DD_VLPRCO</sub>	Very low power run mode current in compute operation - 4 MHz core / 0.8 MHz flash / bus clock disabled, code executing from flash, at 3.0 V	—	167	336	μA	6
I <sub>DD_VLPR</sub>	Very low power run mode current - 4 MHz core / 0.8 MHz bus and flash, all peripheral clocks disabled, code executing from flash, at 3.0 V	—	192	354	μA	6
I <sub>DD_VLPR</sub>	Very low power run mode current - 4 MHz core / 0.8 MHz bus and flash, all peripheral clocks enabled, code executing from flash, at 3.0 V	—	257	431	μA	4, 6
I <sub>DD_VLPW</sub>	Very low power wait mode current - core disabled / 4 MHz system / 0.8 MHz bus / flash disabled (flash doze enabled), all peripheral clocks disabled, at 3.0 V	—	112	286	μA	6
I <sub>DD_STOP</sub>	Stop mode current at 3.0 V	at 25 °C	306	328	μA	—
		at 50 °C	322	349	μA	
		at 70 °C	348	382	μA	
		at 85 °C	384	433	μA	
		at 105 °C	481	578	μA	
I <sub>DD_VLPS</sub>	Very-low-power stop mode current at 3.0 V	at 25 °C	2.71	5.03	μA	—
		at 50 °C	7.05	11.94	μA	
		at 70 °C	15.80	26.87	μA	
		at 85 °C	29.60	47.30	μA	
		at 105 °C	69.13	106.04	μA	

Table continues on the next page...

**Table 9. Power consumption operating behaviors (continued)**

Symbol	Description		Typ.	Max	Unit	Note
I <sub>DD_ULLS</sub>	Low leakage stop mode current at 3.0 V	at 25 °C	2.00	2.7	μA	—
		at 50 °C	3.96	5.14	μA	
		at 70 °C	7.77	10.71	μA	
		at 85 °C	14.15	18.79	μA	
		at 105 °C	33.20	43.67	μA	
I <sub>DD_VLLS3</sub>	Very low-leakage stop mode 3 current at 3.0 V	at 25 °C	1.5	2.2	μA	—
		at 50 °C	2.83	3.55	μA	
		at 70 °C	5.53	7.26	μA	
		at 85 °C	9.92	12.71	μA	
		at 105 °C	22.90	29.23	μA	
I <sub>DD_VLLS1</sub>	Very low-leakage stop mode 1 current at 3.0V	at 25 °C	0.71	1.2	μA	—
		at 50 °C	1.27	1.9	μA	
		at 70 °C	2.48	3.51	μA	
		at 85 °C	4.65	6.29	μA	
		at 105 °C	11.55	14.34	μA	
I <sub>DD_VLLS0</sub>	Very low-leakage stop mode 0 current (SMC_STOPCTRL[PORPO] = 0) at 3.0 V	at 25 °C	0.41	0.9	μA	—
		at 50 °C	0.96	1.56	μA	
		at 70 °C	2.17	3.1	μA	
		at 85 °C	4.35	5.32	μA	
		at 105 °C	11.24	14.00	μA	
I <sub>DD_VLLS0</sub>	Very low-leakage stop mode 0 current (SMC_STOPCTRL[PORPO] = 1) at 3.0 V	at 25 °C	0.23	0.69	μA	7
		at 50 °C	0.77	1.35	μA	
		at 70 °C	1.98	2.52	μA	
		at 85 °C	4.16	5.14	μA	
		at 105 °C	11.05	13.80	μA	

1. The analog supply current is the sum of the active or disabled current for each of the analog modules on the device. See each module's specification for its supply current.
2. MCG configured for PEE mode. CoreMark benchmark compiled using IAR 6.40 with optimization level high, optimized for balanced.
3. MCG configured for FEI mode.
4. Incremental current consumption from peripheral activity is not included.
5. MCG configured for BLPI mode. CoreMark benchmark compiled using IAR 6.40 with optimization level high, optimized for balanced.
6. MCG configured for BLPI mode.
7. No brownout.

**Table 10. Low power mode peripheral adders — typical value**

Symbol	Description	Temperature (°C)						Unit	
		-40	25	50	70	85	105		
I <sub>IREFSTEN4MHz</sub>	4 MHz internal reference clock (IRC) adder. Measured by entering STOP or VLPS mode with 4 MHz IRC enabled.	56	56	56	56	56	56	μA	
I <sub>IREFSTEN32KHz</sub>	32 kHz internal reference clock (IRC) adder. Measured by entering STOP mode with the 32 kHz IRC enabled.	52	52	52	52	52	52	μA	
I <sub>EREFSTEN4MHz</sub>	External 4 MHz crystal clock adder. Measured by entering STOP or VLPS mode with the crystal enabled.	206	228	237	245	251	258	μA	
I <sub>EREFSTEN32KHz</sub>	External 32 kHz crystal clock adder by means of the OSC0_CR[EREFSTEN and EREFSTEN] bits. Measured by entering all modes with the crystal enabled.	VLLS1	440	490	540	560	570	580	nA
		VLLS3	440	490	540	560	570	580	
		LLS	490	490	540	560	570	680	
		VLPS	510	560	560	560	610	680	
		STOP	510	560	560	560	610	680	
I <sub>CMP</sub>	CMP peripheral adder measured by placing the device in VLLS1 mode with CMP enabled using the 6-bit DAC and a single external input for compare. Includes 6-bit DAC power consumption.	22	22	22	22	22	22	μA	
I <sub>RTC</sub>	RTC peripheral adder measured by placing the device in VLLS1 mode with external 32 kHz crystal enabled by means of the RTC_CR[OSCE] bit and the RTC ALARM set for 1 minute. Includes ERCLK32K (32 kHz external crystal) power consumption.	432	357	388	475	532	810	nA	
I <sub>UART</sub>	UART peripheral adder measured by placing the device in STOP or VLPS mode with selected clock source waiting for RX data at 115200 baud rate. Includes selected clock source power consumption.	MCGIRCLK (4 MHz internal reference clock)	66	66	66	66	66	66	μA
		OSCERCLK (4 MHz external crystal)	214	237	246	254	260	268	
I <sub>TPM</sub>	TPM peripheral adder measured by placing the device in STOP or VLPS mode with selected clock source configured for output compare generating 100 Hz clock signal. No load is placed on the I/O generating the clock signal. Includes selected clock source and I/O switching currents.	MCGIRCLK (4 MHz internal reference clock)	86	86	86	86	86	86	μA
		OSCERCLK (4 MHz external crystal)	235	256	265	274	280	287	

Table continues on the next page...

**Table 10. Low power mode peripheral adders — typical value (continued)**

Symbol	Description	Temperature (°C)						Unit
		-40	25	50	70	85	105	
I <sub>BG</sub>	Bandgap adder when BGEN bit is set and device is placed in VLPx, LLS, or VLLSx mode.	45	45	45	45	45	45	μA
I <sub>ADC</sub>	ADC peripheral adder combining the measured values at V <sub>DD</sub> and V <sub>DDA</sub> by placing the device in STOP or VLPS mode. ADC is configured for low power mode using the internal clock and continuous conversions.	366	366	366	366	366	366	μA
I <sub>LCD</sub>	LCD peripheral adder measured by placing the device in VLLS1 mode with external 32 kHz crystal enabled by means of the OSC0_CR[EREFSTEN, EREFSTEN] bits. VIREG disabled, resistor bias network enabled, 1/8 duty cycle, 8 x 36 configuration for driving 288 Segments, 32 Hz frame rate, no LCD glass connected. Includes ERCLK32K (32 kHz external crystal) power consumption.	5	5	5	5	5	5	μA

### 2.2.5.1 Diagram: Typical IDD\_RUN operating behavior

The following data was measured under these conditions:

- MCG in FBE for run mode, and BLPE for VLPR mode
- No GPIOs toggled
- Code execution from flash with cache enabled
- For the ALLOFF curve, all peripheral clocks are disabled except FTFA

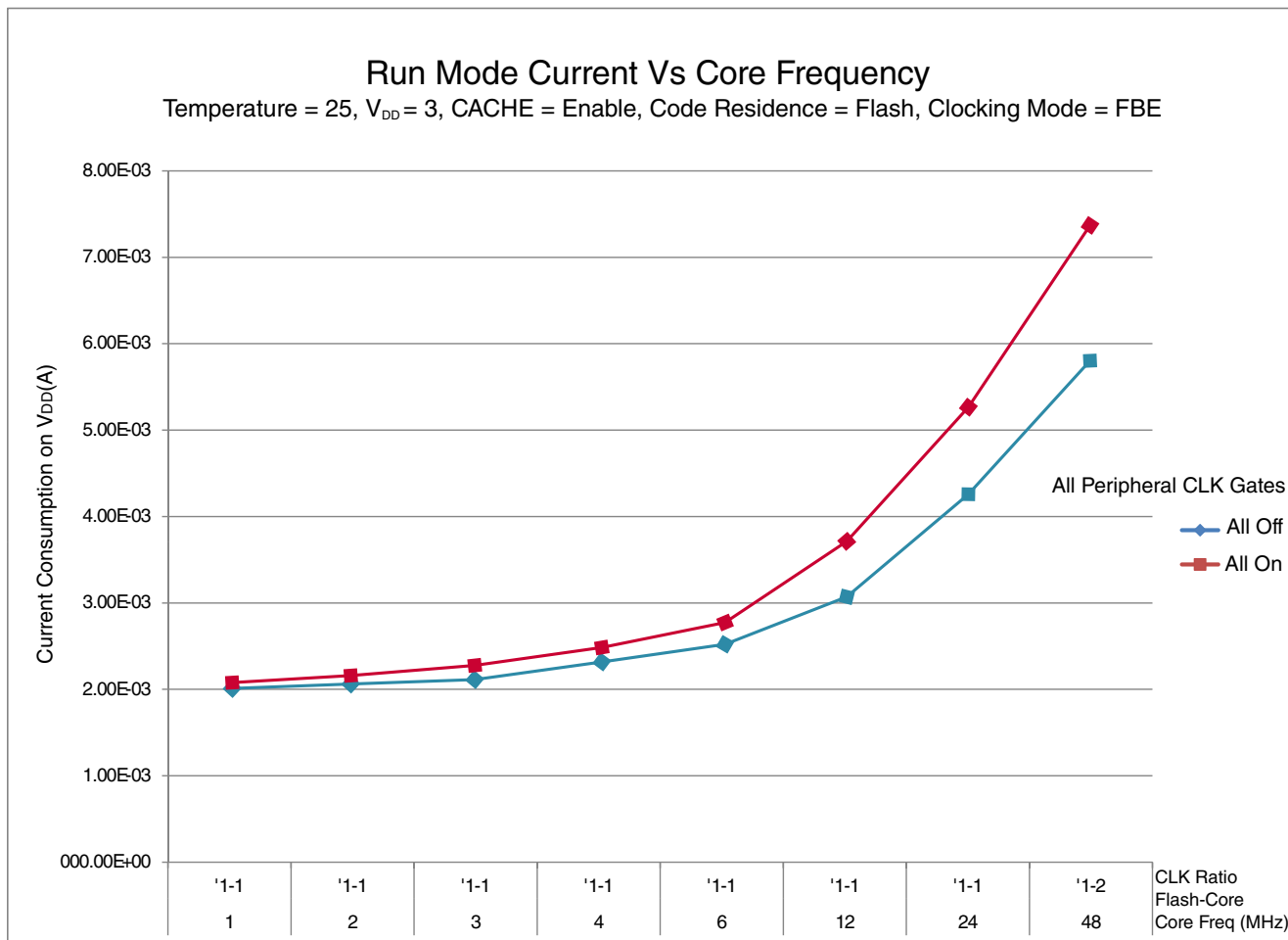

**Figure 3. Run mode supply current vs. core frequency**

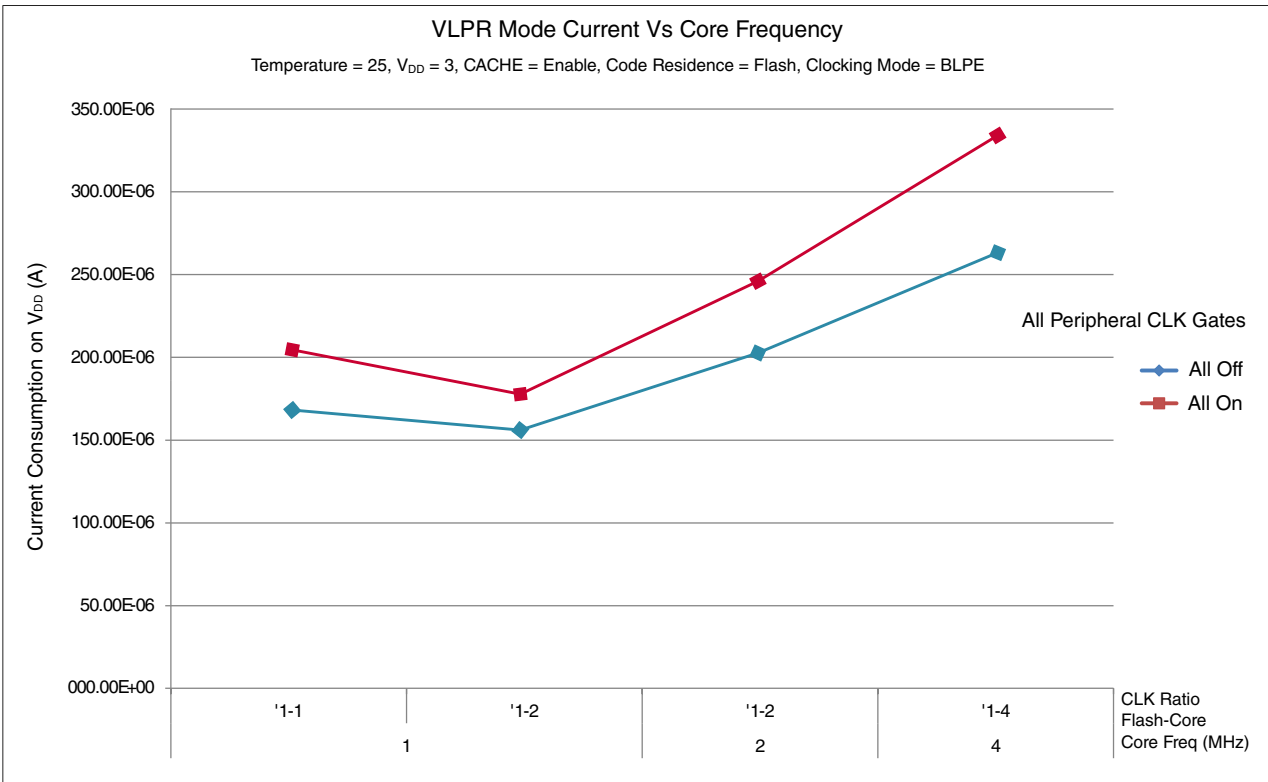

Figure 4. VLPR mode current vs. core frequency

## 2.2.6 EMC radiated emissions operating behaviors

Table 11. EMC radiated emissions operating behaviors

Symbol	Description	Frequency band (MHz)	Typ.	Unit	Notes
V <sub>RE1</sub>	Radiated emissions voltage, band 1	0.15–50	12	dBμV	1,2
V <sub>RE2</sub>	Radiated emissions voltage, band 2	50–150	8	dBμV	
V <sub>RE3</sub>	Radiated emissions voltage, band 3	150–500	7	dBμV	
V <sub>RE4</sub>	Radiated emissions voltage, band 4	500–1000	4	dBμV	
V <sub>RE_IEC</sub>	IEC level	0.15–1000	M	—	2,3

1. Determined according to IEC Standard 61967-1, *Integrated Circuits - Measurement of Electromagnetic Emissions, 150 kHz to 1 GHz Part 1: General Conditions and Definitions* and IEC Standard 61967-2, *Integrated Circuits - Measurement of Electromagnetic Emissions, 150 kHz to 1 GHz Part 2: Measurement of Radiated Emissions—TEM Cell and Wideband TEM Cell Method*. Measurements were made while the microcontroller was running basic application code. The reported emission level is the value of the maximum measured emission, rounded up to the next whole number, from among the measured orientations in each frequency range.
2. V<sub>DD</sub> = 3.3 V, T<sub>A</sub> = 25 °C, f<sub>OSC</sub> = 8 MHz (crystal), f<sub>SYS</sub> = 48 MHz, f<sub>BUS</sub> = 24 MHz
3. Specified according to Annex D of IEC Standard 61967-2, *Measurement of Radiated Emissions—TEM Cell and Wideband TEM Cell Method*

## 2.2.7 Designing with radiated emissions in mind

To find application notes that provide guidance on designing your system to minimize interference from radiated emissions:

1. Go to [www.freescale.com](http://www.freescale.com).
2. Perform a keyword search for “EMC design.”

## 2.2.8 Capacitance attributes

Table 12. Capacitance attributes

Symbol	Description	Min.	Max.	Unit
$C_{IN}$	Input capacitance	—	7	pF

## 2.3 Switching specifications

### 2.3.1 Device clock specifications

Table 13. Device clock specifications

Symbol	Description	Min.	Max.	Unit
Normal run mode				
$f_{SYS}$	System and core clock	—	48	MHz
$f_{BUS}$	Bus clock	—	24	MHz
$f_{FLASH}$	Flash clock	—	24	MHz
$f_{LPTMR}$	LPTMR clock	—	24	MHz
VLPR and VLPS modes <sup>1</sup>				
$f_{SYS}$	System and core clock	—	4	MHz
$f_{BUS}$	Bus clock	—	1	MHz
$f_{FLASH}$	Flash clock	—	1	MHz
$f_{LPTMR}$	LPTMR clock <sup>2</sup>	—	24	MHz
$f_{ERCLK}$	External reference clock	—	16	MHz
$f_{LPTMR\_ERCLK}$	LPTMR external reference clock	—	16	MHz
$f_{osc\_hi\_2}$	Oscillator crystal or resonator frequency — high frequency mode (high range) (MCG_C2[RANGE]=1x)	—	16	MHz
$f_{TPM}$	TPM asynchronous clock	—	8	MHz
$f_{UART0}$	UART0 asynchronous clock	—	8	MHz

1. The frequency limitations in VLPR and VLPS modes here override any frequency specification listed in the timing specification for any other module. These same frequency limits apply to VLPS, whether VLPS was entered from RUN or from VLPR.
2. The LPTMR can be clocked at this speed in VLPR or VLPS only when the source is an external pin.

### 2.3.2 General switching specifications

These general-purpose specifications apply to all signals configured for GPIO and UART signals.

**Table 14. General switching specifications**

Description	Min.	Max.	Unit	Notes
GPIO pin interrupt pulse width (digital glitch filter disabled) — Synchronous path	1.5	—	Bus clock cycles	1
External RESET and NMI pin interrupt pulse width — Asynchronous path	100	—	ns	2
GPIO pin interrupt pulse width — Asynchronous path	16	—	ns	2
Port rise and fall time	—	36	ns	3

1. The greater synchronous and asynchronous timing must be met.
2. This is the shortest pulse that is guaranteed to be recognized.
3. 75 pF load

## 2.4 Thermal specifications

### 2.4.1 Thermal operating requirements

**Table 15. Thermal operating requirements**

Symbol	Description	Min.	Max.	Unit
T <sub>J</sub>	Die junction temperature	-40	125	°C
T <sub>A</sub>	Ambient temperature	-40	105	°C

### 2.4.2 Thermal attributes

**Table 16. Thermal attributes**

Board type	Symbol	Description	100 LQFP	64 LQFP	Unit	Notes
Single-layer (1S)	R <sub>θJA</sub>	Thermal resistance, junction to ambient (natural convection)	64	69	°C/W	1

*Table continues on the next page...*

**Table 16. Thermal attributes (continued)**

Board type	Symbol	Description	100 LQFP	64 LQFP	Unit	Notes
Four-layer (2s2p)	$R_{\theta JA}$	Thermal resistance, junction to ambient (natural convection)	51	51	°C/W	
Single-layer (1S)	$R_{\theta JMA}$	Thermal resistance, junction to ambient (200 ft./min. air speed)	54	58	°C/W	
Four-layer (2s2p)	$R_{\theta JMA}$	Thermal resistance, junction to ambient (200 ft./min. air speed)	45	44	°C/W	
—	$R_{\theta JB}$	Thermal resistance, junction to board	37	33	°C/W	2
—	$R_{\theta JC}$	Thermal resistance, junction to case	19	19	°C/W	3
—	$\Psi_{JT}$	Thermal characterization parameter, junction to package top outside center (natural convection)	4	4	°C/W	4

1. Determined according to JEDEC Standard JESD51-2, *Integrated Circuits Thermal Test Method Environmental Conditions—Natural Convection (Still Air)*, or EIA/JEDEC Standard JESD51-6, *Integrated Circuit Thermal Test Method Environmental Conditions—Forced Convection (Moving Air)*.
2. Determined according to JEDEC Standard JESD51-8, *Integrated Circuit Thermal Test Method Environmental Conditions—Junction-to-Board*.
3. Determined according to Method 1012.1 of MIL-STD 883, *Test Method Standard, Microcircuits*, with the cold plate temperature used for the case temperature. The value includes the thermal resistance of the interface material between the top of the package and the cold plate.
4. Determined according to JEDEC Standard JESD51-2, *Integrated Circuits Thermal Test Method Environmental Conditions—Natural Convection (Still Air)*.

### 3 Peripheral operating requirements and behaviors

#### 3.1 Core modules

##### 3.1.1 SWD electricals

**Table 17. SWD full voltage range electricals**

Symbol	Description	Min.	Max.	Unit
	Operating voltage	1.71	3.6	V
J1	SWD_CLK frequency of operation <ul style="list-style-type: none"> <li>• Serial wire debug</li> </ul>	0	25	MHz
J2	SWD_CLK cycle period	1/J1	—	ns
J3	SWD_CLK clock pulse width			

*Table continues on the next page...*

**Table 17. SWD full voltage range electricals (continued)**

Symbol	Description	Min.	Max.	Unit
	• Serial wire debug	20	—	ns
J4	SWD_CLK rise and fall times	—	3	ns
J9	SWD_DIO input data setup time to SWD_CLK rise	10	—	ns
J10	SWD_DIO input data hold time after SWD_CLK rise	0	—	ns
J11	SWD_CLK high to SWD_DIO data valid	—	32	ns
J12	SWD_CLK high to SWD_DIO high-Z	5	—	ns

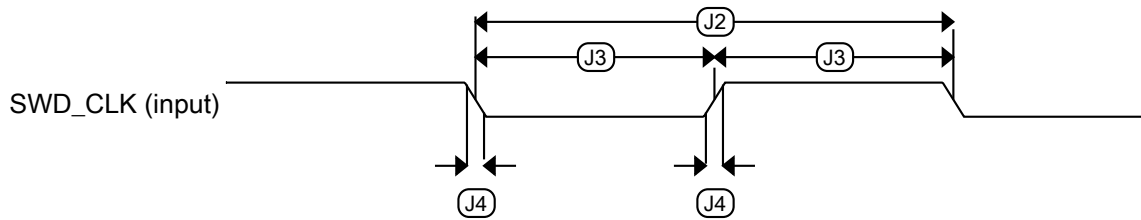

**Figure 5. Serial wire clock input timing**

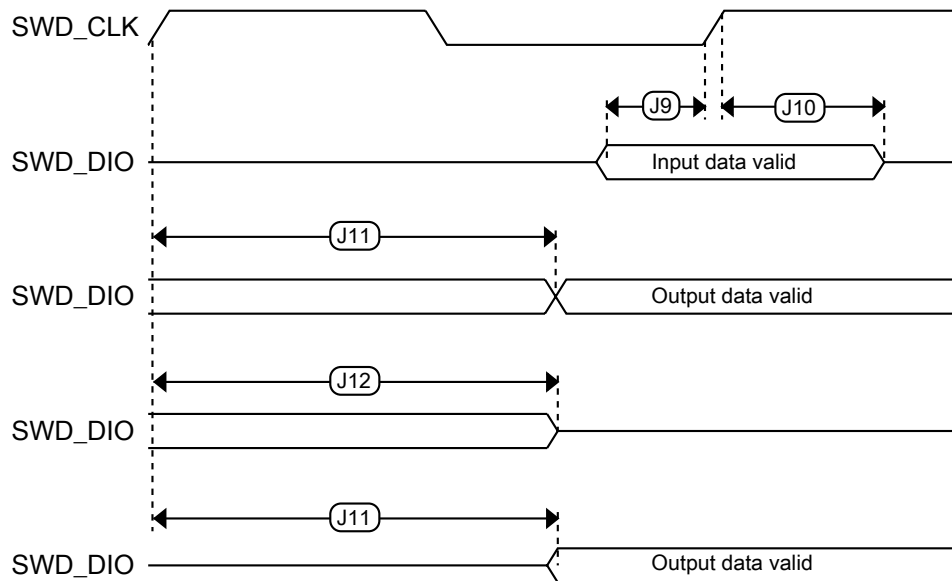

**Figure 6. Serial wire data timing**

## 3.2 System modules

There are no specifications necessary for the device's system modules.

## 3.3 Clock modules

### 3.3.1 MCG specifications

Table 18. MCG specifications

Symbol	Description	Min.	Typ.	Max.	Unit	Notes	
$f_{ints\_ft}$	Internal reference frequency (slow clock) — factory trimmed at nominal $V_{DD}$ and 25 °C	—	32.768	—	kHz		
$f_{ints\_t}$	Internal reference frequency (slow clock) — user trimmed	31.25	—	39.0625	kHz		
$\Delta f_{dco\_res\_t}$	Resolution of trimmed average DCO output frequency at fixed voltage and temperature — using C3[SCTTRIM] and C4[SCFTRIM]	—	$\pm 0.3$	$\pm 0.6$	% $f_{dco}$	1	
$\Delta f_{dco\_t}$	Total deviation of trimmed average DCO output frequency over voltage and temperature	—	+0.5/-0.7	$\pm 3$	% $f_{dco}$	1, 2	
$\Delta f_{dco\_t}$	Total deviation of trimmed average DCO output frequency over fixed voltage and temperature range of 0–70 °C	—	$\pm 0.4$	$\pm 1.5$	% $f_{dco}$	1, 2	
$f_{intf\_ft}$	Internal reference frequency (fast clock) — factory trimmed at nominal $V_{DD}$ and 25 °C	—	4	—	MHz		
$\Delta f_{intf\_ft}$	Frequency deviation of internal reference clock (fast clock) over temperature and voltage — factory trimmed at nominal $V_{DD}$ and 25 °C	—	+1/-2	$\pm 3$	% $f_{intf\_ft}$	2	
$f_{intf\_t}$	Internal reference frequency (fast clock) — user trimmed at nominal $V_{DD}$ and 25 °C	3	—	5	MHz		
$f_{loc\_low}$	Loss of external clock minimum frequency — RANGE = 00	$(3/5) \times f_{ints\_t}$	—	—	kHz		
$f_{loc\_high}$	Loss of external clock minimum frequency —	$(16/5) \times f_{ints\_t}$	—	—	kHz		
FLL							
$f_{fll\_ref}$	FLL reference frequency range	31.25	—	39.0625	kHz		
$f_{dco}$	DCO output frequency range	Low range (DRS = 00) $640 \times f_{fll\_ref}$	20	20.97	25	MHz	3, 4
		Mid range (DRS = 01) $1280 \times f_{fll\_ref}$	40	41.94	48	MHz	
$f_{dco\_t\_DMX3\_2}$	DCO output frequency	Low range (DRS = 00) $732 \times f_{fll\_ref}$	—	23.99	—	MHz	5, 6
		Mid range (DRS = 01)	—	47.97	—	MHz	

Table continues on the next page...

**Table 18. MCG specifications (continued)**

Symbol	Description	Min.	Typ.	Max.	Unit	Notes
	$1464 \times f_{\text{fill\_ref}}$					
$J_{\text{cyc\_fll}}$	FLL period jitter <ul style="list-style-type: none"> <li><math>f_{\text{VCO}} = 48 \text{ MHz}</math></li> </ul>	—	180	—	ps	7
$t_{\text{fill\_acquire}}$	FLL target frequency acquisition time	—	—	1	ms	8
PLL						
$f_{\text{vco}}$	VCO operating frequency	48.0	—	100	MHz	
$I_{\text{pll}}$	PLL operating current <ul style="list-style-type: none"> <li>PLL at 96 MHz (<math>f_{\text{osc\_hi\_1}} = 8 \text{ MHz}</math>, <math>f_{\text{pll\_ref}} = 2 \text{ MHz}</math>, VDIV multiplier = 48)</li> </ul>	—	1060	—	$\mu\text{A}$	9
$I_{\text{pll}}$	PLL operating current <ul style="list-style-type: none"> <li>PLL at 48 MHz (<math>f_{\text{osc\_hi\_1}} = 8 \text{ MHz}</math>, <math>f_{\text{pll\_ref}} = 2 \text{ MHz}</math>, VDIV multiplier = 24)</li> </ul>	—	600	—	$\mu\text{A}$	9
$f_{\text{pll\_ref}}$	PLL reference frequency range	2.0	—	4.0	MHz	
$J_{\text{cyc\_pll}}$	PLL period jitter (RMS) <ul style="list-style-type: none"> <li><math>f_{\text{vco}} = 48 \text{ MHz}</math></li> <li><math>f_{\text{vco}} = 100 \text{ MHz}</math></li> </ul>	—	120	—	ps	10
$J_{\text{acc\_pll}}$	PLL accumulated jitter over 1 $\mu\text{s}$ (RMS) <ul style="list-style-type: none"> <li><math>f_{\text{vco}} = 48 \text{ MHz}</math></li> <li><math>f_{\text{vco}} = 100 \text{ MHz}</math></li> </ul>	—	1350	—	ps	10
$D_{\text{lock}}$	Lock entry frequency tolerance	$\pm 1.49$	—	$\pm 2.98$	%	
$D_{\text{unl}}$	Lock exit frequency tolerance	$\pm 4.47$	—	$\pm 5.97$	%	
$t_{\text{pll\_lock}}$	Lock detector detection time	—	—	$150 \times 10^{-6} + 1075(1/f_{\text{pll\_ref}})$	s	11

- This parameter is measured with the internal reference (slow clock) being used as a reference to the FLL (FEI clock mode).
- The deviation is relative to the factory trimmed frequency at nominal  $V_{\text{DD}}$  and 25 °C,  $f_{\text{ints\_ft}}$ .
- These typical values listed are with the slow internal reference clock (FEI) using factory trim and DMX32 = 0.
- The resulting system clock frequencies must not exceed their maximum specified values. The DCO frequency deviation ( $\Delta f_{\text{dco\_t}}$ ) over voltage and temperature must be considered.
- These typical values listed are with the slow internal reference clock (FEI) using factory trim and DMX32 = 1.
- The resulting clock frequency must not exceed the maximum specified clock frequency of the device.
- This specification is based on standard deviation (RMS) of period or frequency.
- This specification applies to any time the FLL reference source or reference divider is changed, trim value is changed, DMX32 bit is changed, DRS bits are changed, or changing from FLL disabled (BLPE, BLPI) to FLL enabled (FEI, FEE, FBE, FBI). If a crystal/resonator is being used as the reference, this specification assumes it is already running.
- Excludes any oscillator currents that are also consuming power while PLL is in operation.
- This specification was obtained using a Freescale developed PCB. PLL jitter is dependent on the noise characteristics of each PCB and results will vary.
- This specification applies to any time the PLL VCO divider or reference divider is changed, or changing from PLL disabled (BLPE, BLPI) to PLL enabled (PBE, PEE). If a crystal/resonator is being used as the reference, this specification assumes it is already running.

### 3.3.2 Oscillator electrical specifications

#### 3.3.2.1 Oscillator DC electrical specifications

**Table 19. Oscillator DC electrical specifications**

Symbol	Description	Min.	Typ.	Max.	Unit	Notes
V <sub>DD</sub>	Supply voltage	1.71	—	3.6	V	
I <sub>DDOSC</sub>	Supply current — low-power mode (HGO=0) <ul style="list-style-type: none"> <li>• 32 kHz</li> <li>• 4 MHz</li> <li>• 8 MHz (RANGE=01)</li> <li>• 16 MHz</li> <li>• 24 MHz</li> <li>• 32 MHz</li> </ul>	—	500	—	nA	1
		—	200	—	μA	
		—	300	—	μA	
		—	950	—	μA	
		—	1.2	—	mA	
		—	1.5	—	mA	
I <sub>DDOSC</sub>	Supply current — high gain mode (HGO=1) <ul style="list-style-type: none"> <li>• 32 kHz</li> <li>• 4 MHz</li> <li>• 8 MHz (RANGE=01)</li> <li>• 16 MHz</li> <li>• 24 MHz</li> <li>• 32 MHz</li> </ul>	—	25	—	μA	1
		—	400	—	μA	
		—	500	—	μA	
		—	2.5	—	mA	
		—	3	—	mA	
		—	4	—	mA	
C <sub>x</sub>	EXTAL load capacitance	—	—	—		2, 3
C <sub>y</sub>	XTAL load capacitance	—	—	—		2, 3
R <sub>F</sub>	Feedback resistor — low-frequency, low-power mode (HGO=0)	—	—	—	MΩ	2, 4
	Feedback resistor — low-frequency, high-gain mode (HGO=1)	—	10	—	MΩ	
	Feedback resistor — high-frequency, low-power mode (HGO=0)	—	—	—	MΩ	
	Feedback resistor — high-frequency, high-gain mode (HGO=1)	—	1	—	MΩ	
R <sub>S</sub>	Series resistor — low-frequency, low-power mode (HGO=0)	—	—	—	kΩ	
	Series resistor — low-frequency, high-gain mode (HGO=1)	—	200	—	kΩ	
	Series resistor — high-frequency, low-power mode (HGO=0)	—	—	—	kΩ	
	Series resistor — high-frequency, high-gain mode (HGO=1)					

Table continues on the next page...

**Table 19. Oscillator DC electrical specifications (continued)**

Symbol	Description	Min.	Typ.	Max.	Unit	Notes
		—	0	—	k $\Omega$	
$V_{pp}^5$	Peak-to-peak amplitude of oscillation (oscillator mode) — low-frequency, low-power mode (HGO=0)	—	0.6	—	V	
	Peak-to-peak amplitude of oscillation (oscillator mode) — low-frequency, high-gain mode (HGO=1)	—	$V_{DD}$	—	V	
	Peak-to-peak amplitude of oscillation (oscillator mode) — high-frequency, low-power mode (HGO=0)	—	0.6	—	V	
	Peak-to-peak amplitude of oscillation (oscillator mode) — high-frequency, high-gain mode (HGO=1)	—	$V_{DD}$	—	V	

1.  $V_{DD}=3.3$  V, Temperature =25 °C
2. See crystal or resonator manufacturer's recommendation
3.  $C_x, C_y$  can be provided by using the integrated capacitors when the low frequency oscillator (RANGE = 00) is used. For all other cases external capacitors must be used.
4. When low power mode is selected,  $R_F$  is integrated and must not be attached externally.
5. The EXTAL and XTAL pins should only be connected to required oscillator components and must not be connected to any other devices.

### 3.3.2.2 Oscillator frequency specifications

**Table 20. Oscillator frequency specifications**

Symbol	Description	Min.	Typ.	Max.	Unit	Notes
$f_{osc\_lo}$	Oscillator crystal or resonator frequency — low-frequency mode (MCG_C2[RANGE]=00)	32	—	40	kHz	
$f_{osc\_hi\_1}$	Oscillator crystal or resonator frequency — high-frequency mode (low range) (MCG_C2[RANGE]=01)	3	—	8	MHz	
$f_{osc\_hi\_2}$	Oscillator crystal or resonator frequency — high frequency mode (high range) (MCG_C2[RANGE]=1x)	8	—	32	MHz	
$f_{ec\_extal}$	Input clock frequency (external clock mode)	—	—	48	MHz	1, 2
$t_{dc\_extal}$	Input clock duty cycle (external clock mode)	40	50	60	%	
$t_{cst}$	Crystal startup time — 32 kHz low-frequency, low-power mode (HGO=0)	—	750	—	ms	3, 4
	Crystal startup time — 32 kHz low-frequency, high-gain mode (HGO=1)	—	250	—	ms	
	Crystal startup time — 8 MHz high-frequency (MCG_C2[RANGE]=01), low-power mode (HGO=0)	—	0.6	—	ms	
	Crystal startup time — 8 MHz high-frequency (MCG_C2[RANGE]=01), high-gain mode (HGO=1)	—	1	—	ms	

## Peripheral operating requirements and behaviors

1. Other frequency limits may apply when external clock is being used as a reference for the FLL or PLL.
2. When transitioning from FEI or FBI to FBE mode, restrict the frequency of the input clock so that, when it is divided by FRDIV, it remains within the limits of the DCO input clock frequency.
3. Proper PC board layout procedures must be followed to achieve specifications.
4. Crystal startup time is defined as the time between the oscillator being enabled and the OSCINIT bit in the MCG\_S register being set.

## 3.4 Memories and memory interfaces

### 3.4.1 Flash electrical specifications

This section describes the electrical characteristics of the flash memory module.

#### 3.4.1.1 Flash timing specifications — program and erase

The following specifications represent the amount of time the internal charge pumps are active and do not include command overhead.

**Table 21. NVM program/erase timing specifications**

Symbol	Description	Min.	Typ.	Max.	Unit	Notes
$t_{hvp\text{gm}4}$	Longword Program high-voltage time	—	7.5	18	$\mu\text{s}$	—
$t_{h\text{versscr}}$	Sector Erase high-voltage time	—	13	113	ms	1
$t_{h\text{versblk}128\text{k}}$	Erase Block high-voltage time for 128 KB	—	52	452	ms	1
$t_{h\text{versall}}$	Erase All high-voltage time	—	52	452	ms	1

1. Maximum time based on expectations at cycling end-of-life.

#### 3.4.1.2 Flash timing specifications — commands

**Table 22. Flash command timing specifications**

Symbol	Description	Min.	Typ.	Max.	Unit	Notes
$t_{rd1\text{blk}128\text{k}}$	Read 1s Block execution time • 128 KB program flash	—	—	1.7	ms	—
$t_{rd1\text{sec}1\text{k}}$	Read 1s Section execution time (flash sector)	—	—	60	$\mu\text{s}$	1
$t_{pgm\text{chk}}$	Program Check execution time	—	—	45	$\mu\text{s}$	1
$t_{rd\text{src}}$	Read Resource execution time	—	—	30	$\mu\text{s}$	1
$t_{pgm4}$	Program Longword execution time	—	65	145	$\mu\text{s}$	—
$t_{ers\text{blk}128\text{k}}$	Erase Flash Block execution time • 128 KB program flash	—	88	600	ms	2

Table continues on the next page...

**Table 22. Flash command timing specifications (continued)**

Symbol	Description	Min.	Typ.	Max.	Unit	Notes
$t_{ersscr}$	Erase Flash Sector execution time	—	14	114	ms	2
$t_{rd1all}$	Read 1s All Blocks execution time	—	—	1.8	ms	—
$t_{rdonce}$	Read Once execution time	—	—	25	$\mu$ s	1
$t_{pgmonce}$	Program Once execution time	—	65	—	$\mu$ s	—
$t_{ersall}$	Erase All Blocks execution time	—	175	1300	ms	2
$t_{vfykey}$	Verify Backdoor Access Key execution time	—	—	30	$\mu$ s	1

1. Assumes 25 MHz flash clock frequency.
2. Maximum times for erase parameters based on expectations at cycling end-of-life.

### 3.4.1.3 Flash high voltage current behaviors

**Table 23. Flash high voltage current behaviors**

Symbol	Description	Min.	Typ.	Max.	Unit
$I_{DD\_PGM}$	Average current adder during high voltage flash programming operation	—	2.5	6.0	mA
$I_{DD\_ERS}$	Average current adder during high voltage flash erase operation	—	1.5	4.0	mA

### 3.4.1.4 Reliability specifications

**Table 24. NVM reliability specifications**

Symbol	Description	Min.	Typ. <sup>1</sup>	Max.	Unit	Notes
Program Flash						
$t_{nvmretp10k}$	Data retention after up to 10 K cycles	5	50	—	years	—
$t_{nvmretp1k}$	Data retention after up to 1 K cycles	20	100	—	years	—
$n_{nvmcyep}$	Cycling endurance	10 K	50 K	—	cycles	2

1. Typical data retention values are based on measured response accelerated at high temperature and derated to a constant 25 °C use profile. Engineering Bulletin EB618 does not apply to this technology. Typical endurance defined in Engineering Bulletin EB619.
2. Cycling endurance represents number of program/erase cycles at  $-40\text{ °C} \leq T_j \leq 125\text{ °C}$ .

## 3.5 Security and integrity modules

There are no specifications necessary for the device's security and integrity modules.

## 3.6 Analog

### 3.6.1 ADC electrical specifications

All ADC channels meet the 12-bit single-ended accuracy specifications.

#### 3.6.1.1 12-bit ADC operating conditions

Table 25. 12-bit ADC operating conditions

Symbol	Description	Conditions	Min.	Typ. <sup>1</sup>	Max.	Unit	Notes
V <sub>DDA</sub>	Supply voltage	Absolute	1.71	—	3.6	V	—
ΔV <sub>DDA</sub>	Supply voltage	Delta to V <sub>DD</sub> (V <sub>DD</sub> – V <sub>DDA</sub> )	-100	0	+100	mV	2
ΔV <sub>SSA</sub>	Ground voltage	Delta to V <sub>SS</sub> (V <sub>SS</sub> – V <sub>SSA</sub> )	-100	0	+100	mV	2
V <sub>REFH</sub>	ADC reference voltage high		1.13	V <sub>DDA</sub>	V <sub>DDA</sub>	V	
V <sub>REFL</sub>	ADC reference voltage low		V <sub>SSA</sub>	V <sub>SSA</sub>	V <sub>SSA</sub>	V	
V <sub>ADIN</sub>	Input voltage		V <sub>REFL</sub>	—	V <sub>REFH</sub>	V	—
C <sub>ADIN</sub>	Input capacitance	• 8-bit / 10-bit / 12-bit modes	—	4	5	pF	—
R <sub>ADIN</sub>	Input series resistance		—	2	5	kΩ	—
R <sub>AS</sub>	Analog source resistance (external)	12-bit modes f <sub>ADCK</sub> < 4 MHz	—	—	5	kΩ	3
f <sub>ADCK</sub>	ADC conversion clock frequency	≤ 12-bit mode	1.0	—	18.0	MHz	4
C <sub>rate</sub>	ADC conversion rate	≤ 12-bit modes No ADC hardware averaging Continuous conversions enabled, subsequent conversion time	20.000	—	818.330	Ksps	5

1. Typical values assume V<sub>DDA</sub> = 3.0 V, Temp = 25 °C, f<sub>ADCK</sub> = 1.0 MHz, unless otherwise stated. Typical values are for reference only, and are not tested in production.
2. DC potential difference.
3. This resistance is external to MCU. To achieve the best results, the analog source resistance must be kept as low as possible. The results in this data sheet were derived from a system that had < 8 Ω analog source resistance. The R<sub>AS</sub>/C<sub>AS</sub> time constant should be kept to < 1 ns.
4. To use the maximum ADC conversion clock frequency, CFG2[ADHSC] must be set and CFG1[ADLPC] must be clear.
5. For guidelines and examples of conversion rate calculation, download the [ADC calculator tool](#).

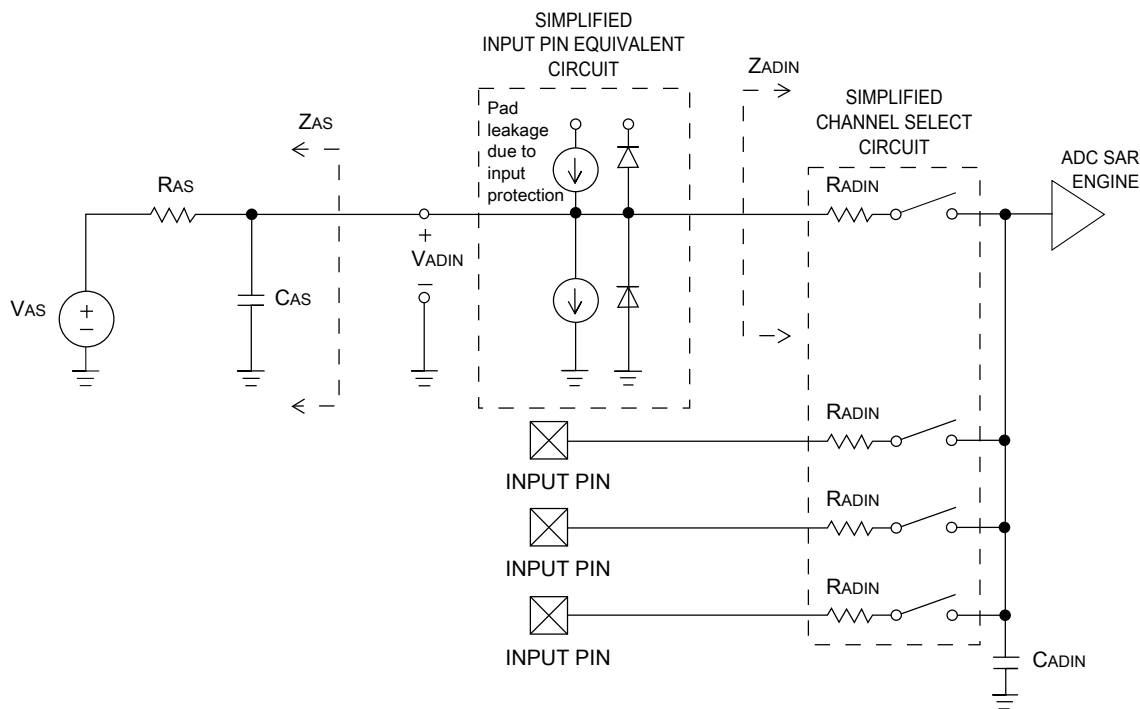

Figure 7. ADC input impedance equivalency diagram

### 3.6.1.2 12-bit ADC electrical characteristics

Table 26. 12-bit ADC characteristics ( $V_{REFH} = V_{DDA}$ ,  $V_{REFL} = V_{SSA}$ )

Symbol	Description	Conditions <sup>1</sup>	Min.	Typ. <sup>2</sup>	Max.	Unit	Notes
$I_{DDA\_ADC}$	Supply current		0.215	—	1.7	mA	3
$f_{ADACK}$	ADC asynchronous clock source	• ADLPC = 1, ADHSC = 0	1.2	2.4	3.9	MHz	$t_{ADACK} = 1/f_{ADACK}$
		• ADLPC = 1, ADHSC = 1	2.4	4.0	6.1	MHz	
		• ADLPC = 0, ADHSC = 0	3.0	5.2	7.3	MHz	
		• ADLPC = 0, ADHSC = 1	4.4	6.2	9.5	MHz	
	Sample Time	See Reference Manual chapter for sample times					
TUE	Total unadjusted error	• 12-bit modes • <12-bit modes	—	±4 ±1.4	±6.8 ±2.1	LSB <sup>4</sup>	5
DNL	Differential non-linearity	• 12-bit modes • <12-bit modes	—	±0.7 ±0.2	-1.1 to +1.9 -0.3 to 0.5	LSB <sup>4</sup>	5

Table continues on the next page...

**Table 26. 12-bit ADC characteristics ( $V_{REFH} = V_{DDA}$ ,  $V_{REFL} = V_{SSA}$ ) (continued)**

Symbol	Description	Conditions <sup>1</sup>	Min.	Typ. <sup>2</sup>	Max.	Unit	Notes
INL	Integral non-linearity	<ul style="list-style-type: none"> <li>12-bit modes</li> <li>&lt;12-bit modes</li> </ul>	—	±1.0	-2.7 to +1.9	LSB <sup>4</sup>	5
E <sub>FS</sub>	Full-scale error	<ul style="list-style-type: none"> <li>12-bit modes</li> <li>&lt;12-bit modes</li> </ul>	—	-4	-5.4	LSB <sup>4</sup>	$V_{ADIN} = V_{DDA}$ <sup>5</sup>
E <sub>Q</sub>	Quantization error	<ul style="list-style-type: none"> <li>12-bit modes</li> </ul>	—	—	±0.5	LSB <sup>4</sup>	
E <sub>IL</sub>	Input leakage error		$I_{in} \times R_{AS}$			mV	$I_{in}$ = leakage current (refer to the MCU's voltage and current operating ratings)
	Temp sensor slope	Across the full temperature range of the device	1.55	1.62	1.69	mV/°C	6
V <sub>TEMP25</sub>	Temp sensor voltage	25 °C	706	716	726	mV	6

1. All accuracy numbers assume the ADC is calibrated with  $V_{REFH} = V_{DDA}$
2. Typical values assume  $V_{DDA} = 3.0$  V, Temp = 25 °C,  $f_{ADCK} = 2.0$  MHz unless otherwise stated. Typical values are for reference only and are not tested in production.
3. The ADC supply current depends on the ADC conversion clock speed, conversion rate and ADC\_CFG1[ADLPC] (low power). For lowest power operation, ADC\_CFG1[ADLPC] must be set, the ADC\_CFG2[ADHSC] bit must be clear with 1 MHz ADC conversion clock speed.
4.  $1 \text{ LSB} = (V_{REFH} - V_{REFL})/2^N$
5. ADC conversion clock < 16 MHz, Max hardware averaging (AVGE = %1, AVGS = %11)
6. ADC conversion clock < 3 MHz

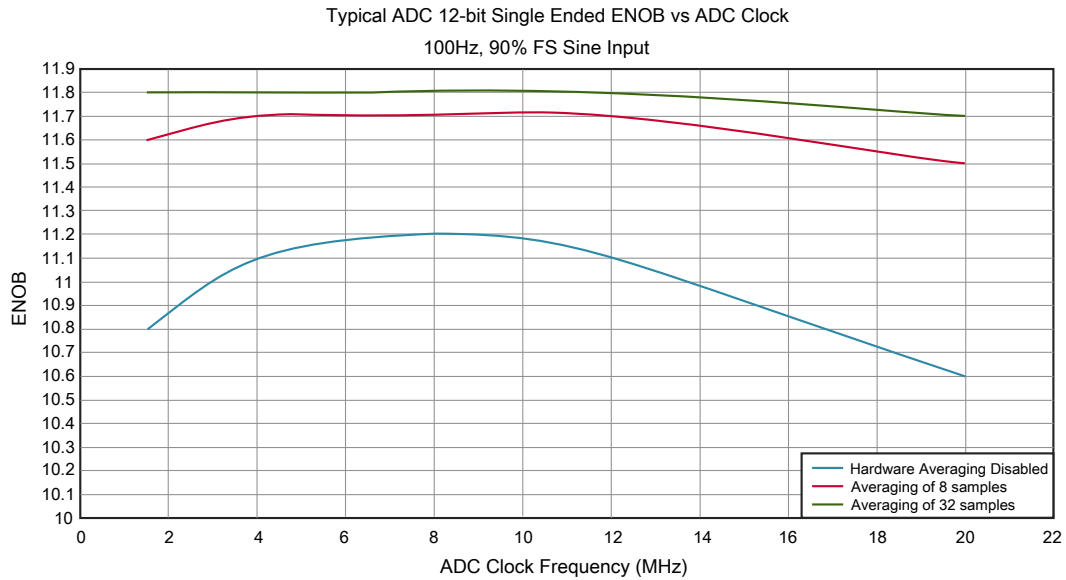

Figure 8. Typical ENOB vs. ADC\_CLK for 12-bit single-ended mode

### 3.6.2 CMP and 6-bit DAC electrical specifications

Table 27. Comparator and 6-bit DAC electrical specifications

Symbol	Description	Min.	Typ.	Max.	Unit
$V_{DD}$	Supply voltage	1.71	—	3.6	V
$I_{DDHS}$	Supply current, High-speed mode (EN=1, PMODE=1)	—	—	200	$\mu$ A
$I_{DDL S}$	Supply current, low-speed mode (EN=1, PMODE=0)	—	—	20	$\mu$ A
$V_{AIN}$	Analog input voltage	$V_{SS} - 0.3$	—	$V_{DD}$	V
$V_{AIO}$	Analog input offset voltage	—	—	20	mV
$V_H$	Analog comparator hysteresis <sup>1</sup> <ul style="list-style-type: none"> <li>• CR0[HYSTCTR] = 00</li> <li>• CR0[HYSTCTR] = 01</li> <li>• CR0[HYSTCTR] = 10</li> <li>• CR0[HYSTCTR] = 11</li> </ul>	—	5 10 20 30	—	mV
$V_{CMPOh}$	Output high	$V_{DD} - 0.5$	—	—	V
$V_{CMPOl}$	Output low	—	—	0.5	V
$t_{DHS}$	Propagation delay, high-speed mode (EN=1, PMODE=1)	20	50	200	ns
$t_{DLS}$	Propagation delay, low-speed mode (EN=1, PMODE=0)	80	250	600	ns
	Analog comparator initialization delay <sup>2</sup>	—	—	40	$\mu$ s

Table continues on the next page...

**Table 27. Comparator and 6-bit DAC electrical specifications (continued)**

Symbol	Description	Min.	Typ.	Max.	Unit
I <sub>DAC6b</sub>	6-bit DAC current adder (enabled)	—	7	—	μA
INL	6-bit DAC integral non-linearity	-0.5	—	0.5	LSB <sup>3</sup>
DNL	6-bit DAC differential non-linearity	-0.3	—	0.3	LSB

1. Typical hysteresis is measured with input voltage range limited to 0.6 to V<sub>DD</sub>-0.6 V.
2. Comparator initialization delay is defined as the time between software writes to change control inputs (Writes to CMP\_DACCR[DACEN], CMP\_DACCR[VRSEL], CMP\_DACCR[VOSEL], CMP\_MUXCR[PSEL], and CMP\_MUXCR[MSEL]) and the comparator output settling to a stable level.
3. 1 LSB = V<sub>reference</sub>/64

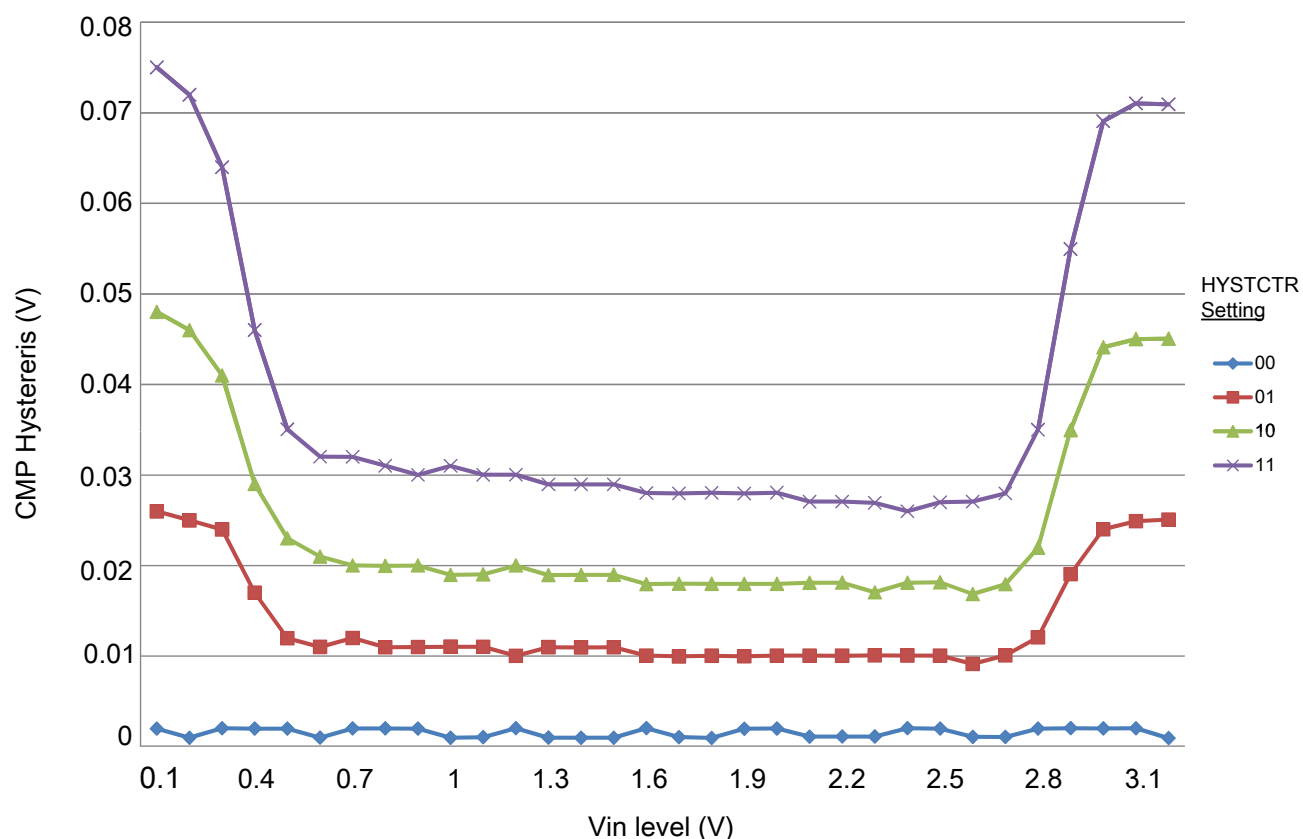

**Figure 9. Typical hysteresis vs. Vin level (VDD = 3.3 V, PMODE = 0)**

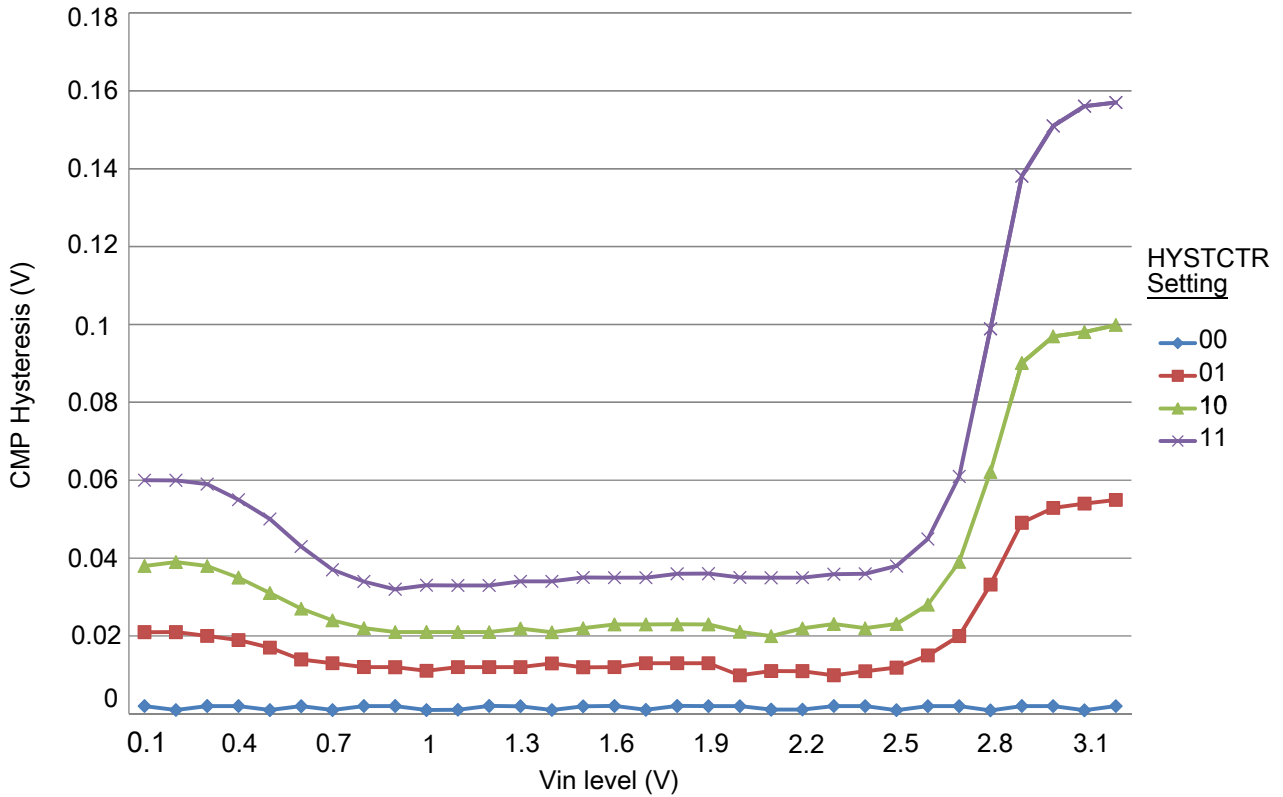

Figure 10. Typical hysteresis vs. Vin level (VDD = 3.3 V, PMODE = 1)

### 3.7 Timers

See [General switching specifications](#).

### 3.8 Communication interfaces

#### 3.8.1 SPI switching specifications

The Serial Peripheral Interface (SPI) provides a synchronous serial bus with master and slave operations. Many of the transfer attributes are programmable. The following tables provide timing characteristics for classic SPI timing modes. See the SPI chapter of the chip's Reference Manual for information about the modified transfer formats used for communicating with slower peripheral devices.

All timing is shown with respect to 20%  $V_{DD}$  and 80%  $V_{DD}$  thresholds, unless noted, as well as input signal transitions of 3 ns and a 30 pF maximum load on all SPI pins.

**Table 28. SPI master mode timing on slew rate disabled pads**

Num.	Symbol	Description	Min.	Max.	Unit	Note
1	$f_{op}$	Frequency of operation	$f_{periph}/2048$	$f_{periph}/2$	Hz	1
2	$t_{SPSCK}$	SPSCK period	$2 \times t_{periph}$	$2048 \times t_{periph}$	ns	2
3	$t_{Lead}$	Enable lead time	1/2	—	$t_{SPSCK}$	—
4	$t_{Lag}$	Enable lag time	1/2	—	$t_{SPSCK}$	—
5	$t_{WSPSCK}$	Clock (SPSCK) high or low time	$t_{periph} - 30$	$1024 \times t_{periph}$	ns	—
6	$t_{SU}$	Data setup time (inputs)	18	—	ns	—
7	$t_{HI}$	Data hold time (inputs)	0	—	ns	—
8	$t_v$	Data valid (after SPSCK edge)	—	15	ns	—
9	$t_{HO}$	Data hold time (outputs)	0	—	ns	—
10	$t_{RI}$	Rise time input	—	$t_{periph} - 25$	ns	—
	$t_{FI}$	Fall time input				
11	$t_{RO}$	Rise time output	—	25	ns	—
	$t_{FO}$	Fall time output				

1. For SPI0  $f_{periph}$  is the bus clock ( $f_{BUS}$ ). For SPI1  $f_{periph}$  is the system clock ( $f_{SYS}$ ).
2.  $t_{periph} = 1/f_{periph}$

**Table 29. SPI master mode timing on slew rate enabled pads**

Num.	Symbol	Description	Min.	Max.	Unit	Note
1	$f_{op}$	Frequency of operation	$f_{periph}/2048$	$f_{periph}/2$	Hz	1
2	$t_{SPSCK}$	SPSCK period	$2 \times t_{periph}$	$2048 \times t_{periph}$	ns	2
3	$t_{Lead}$	Enable lead time	1/2	—	$t_{SPSCK}$	—
4	$t_{Lag}$	Enable lag time	1/2	—	$t_{SPSCK}$	—
5	$t_{WSPSCK}$	Clock (SPSCK) high or low time	$t_{periph} - 30$	$1024 \times t_{periph}$	ns	—
6	$t_{SU}$	Data setup time (inputs)	96	—	ns	—
7	$t_{HI}$	Data hold time (inputs)	0	—	ns	—
8	$t_v$	Data valid (after SPSCK edge)	—	52	ns	—
9	$t_{HO}$	Data hold time (outputs)	0	—	ns	—
10	$t_{RI}$	Rise time input	—	$t_{periph} - 25$	ns	—
	$t_{FI}$	Fall time input				
11	$t_{RO}$	Rise time output	—	36	ns	—
	$t_{FO}$	Fall time output				

1. For SPI0  $f_{periph}$  is the bus clock ( $f_{BUS}$ ). For SPI1  $f_{periph}$  is the system clock ( $f_{SYS}$ ).
2.  $t_{periph} = 1/f_{periph}$

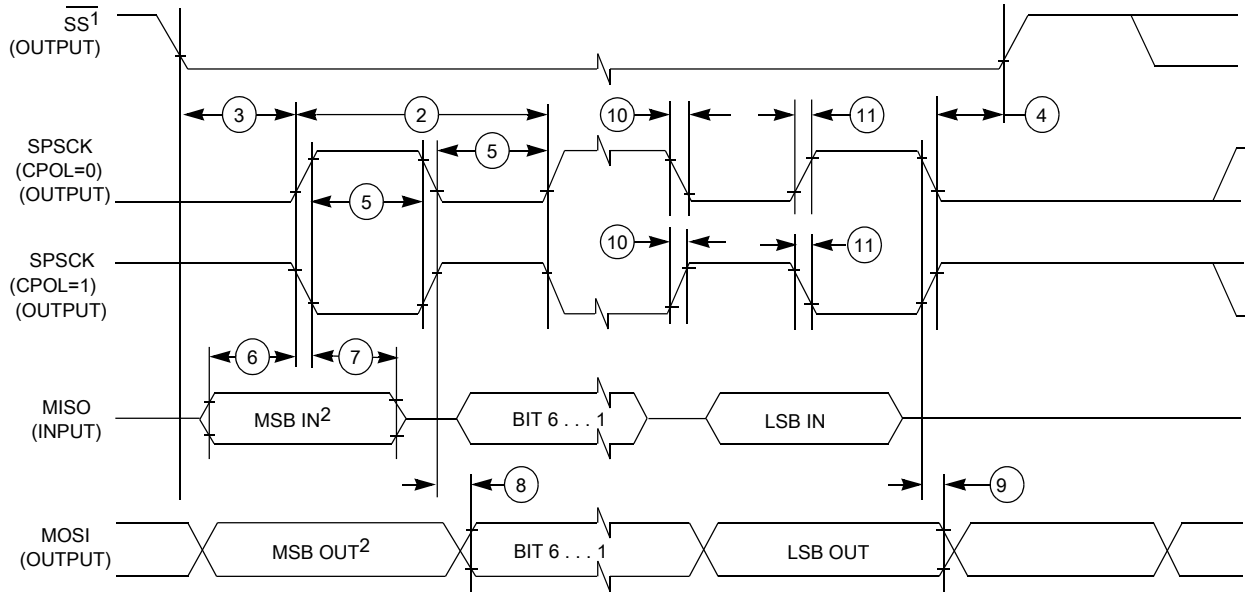

1. If configured as an output.
2. LSBF = 0. For LSBF = 1, bit order is LSB, bit 1, ..., bit 6, MSB.

**Figure 11. SPI master mode timing (CPHA = 0)**

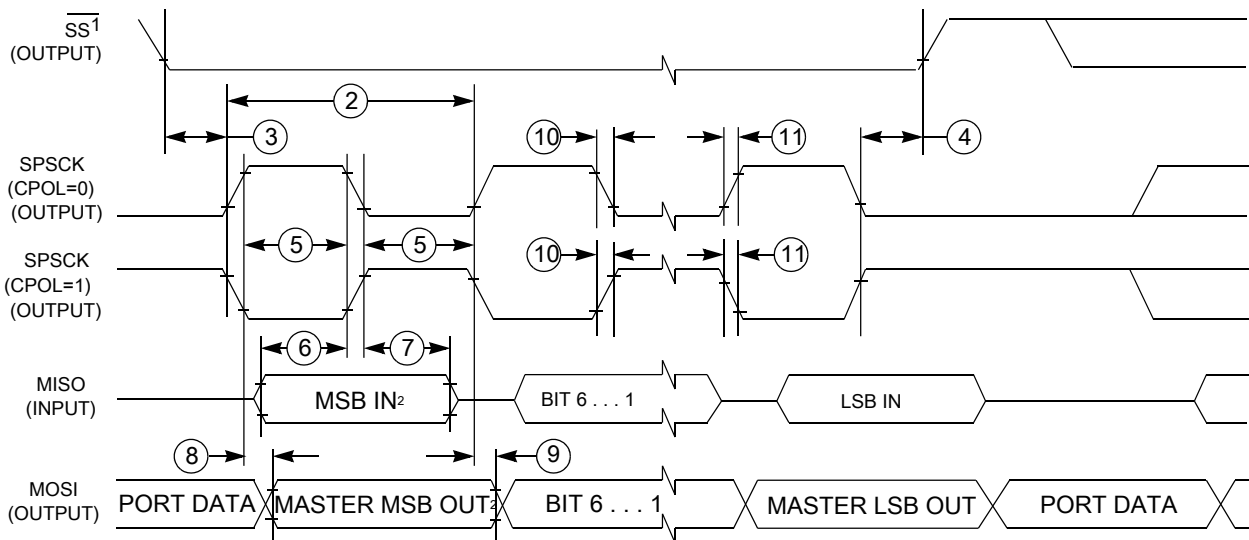

1. If configured as output
2. LSBF = 0. For LSBF = 1, bit order is LSB, bit 1, ..., bit 6, MSB.

**Figure 12. SPI master mode timing (CPHA = 1)**

**Table 30. SPI slave mode timing on slew rate disabled pads**

Num.	Symbol	Description	Min.	Max.	Unit	Note
1	$f_{op}$	Frequency of operation	0	$f_{periph}/4$	Hz	1
2	$t_{SPSCCK}$	SPSCCK period	$4 \times t_{periph}$	—	ns	2
3	$t_{Lead}$	Enable lead time	1	—	$t_{periph}$	—

Table continues on the next page...

**Table 30. SPI slave mode timing on slew rate disabled pads (continued)**

Num.	Symbol	Description	Min.	Max.	Unit	Note
4	$t_{Lag}$	Enable lag time	1	—	$t_{periph}$	—
5	$t_{WSPSCK}$	Clock (SPSCK) high or low time	$t_{periph} - 30$	—	ns	—
6	$t_{SU}$	Data setup time (inputs)	2.5	—	ns	—
7	$t_{HI}$	Data hold time (inputs)	3.5	—	ns	—
8	$t_a$	Slave access time	—	$t_{periph}$	ns	3
9	$t_{dis}$	Slave MISO disable time	—	$t_{periph}$	ns	4
10	$t_v$	Data valid (after SPSCK edge)	—	31	ns	—
11	$t_{HO}$	Data hold time (outputs)	0	—	ns	—
12	$t_{RI}$	Rise time input	—	$t_{periph} - 25$	ns	—
	$t_{FI}$	Fall time input				
13	$t_{RO}$	Rise time output	—	25	ns	—
	$t_{FO}$	Fall time output				

1. For SPI0  $f_{periph}$  is the bus clock ( $f_{BUS}$ ). For SPI1  $f_{periph}$  is the system clock ( $f_{SYS}$ ).
2.  $t_{periph} = 1/f_{periph}$
3. Time to data active from high-impedance state
4. Hold time to high-impedance state

**Table 31. SPI slave mode timing on slew rate enabled pads**

Num.	Symbol	Description	Min.	Max.	Unit	Note
1	$f_{op}$	Frequency of operation	0	$f_{periph}/4$	Hz	1
2	$t_{SPSCK}$	SPSCK period	$4 \times t_{periph}$	—	ns	2
3	$t_{Lead}$	Enable lead time	1	—	$t_{periph}$	—
4	$t_{Lag}$	Enable lag time	1	—	$t_{periph}$	—
5	$t_{WSPSCK}$	Clock (SPSCK) high or low time	$t_{periph} - 30$	—	ns	—
6	$t_{SU}$	Data setup time (inputs)	2	—	ns	—
7	$t_{HI}$	Data hold time (inputs)	7	—	ns	—
8	$t_a$	Slave access time	—	$t_{periph}$	ns	3
9	$t_{dis}$	Slave MISO disable time	—	$t_{periph}$	ns	4
10	$t_v$	Data valid (after SPSCK edge)	—	122	ns	—
11	$t_{HO}$	Data hold time (outputs)	0	—	ns	—
12	$t_{RI}$	Rise time input	—	$t_{periph} - 25$	ns	—
	$t_{FI}$	Fall time input				
13	$t_{RO}$	Rise time output	—	36	ns	—
	$t_{FO}$	Fall time output				

1. For SPI0  $f_{periph}$  is the bus clock ( $f_{BUS}$ ). For SPI1  $f_{periph}$  is the system clock ( $f_{SYS}$ ).
2.  $t_{periph} = 1/f_{periph}$
3. Time to data active from high-impedance state
4. Hold time to high-impedance state

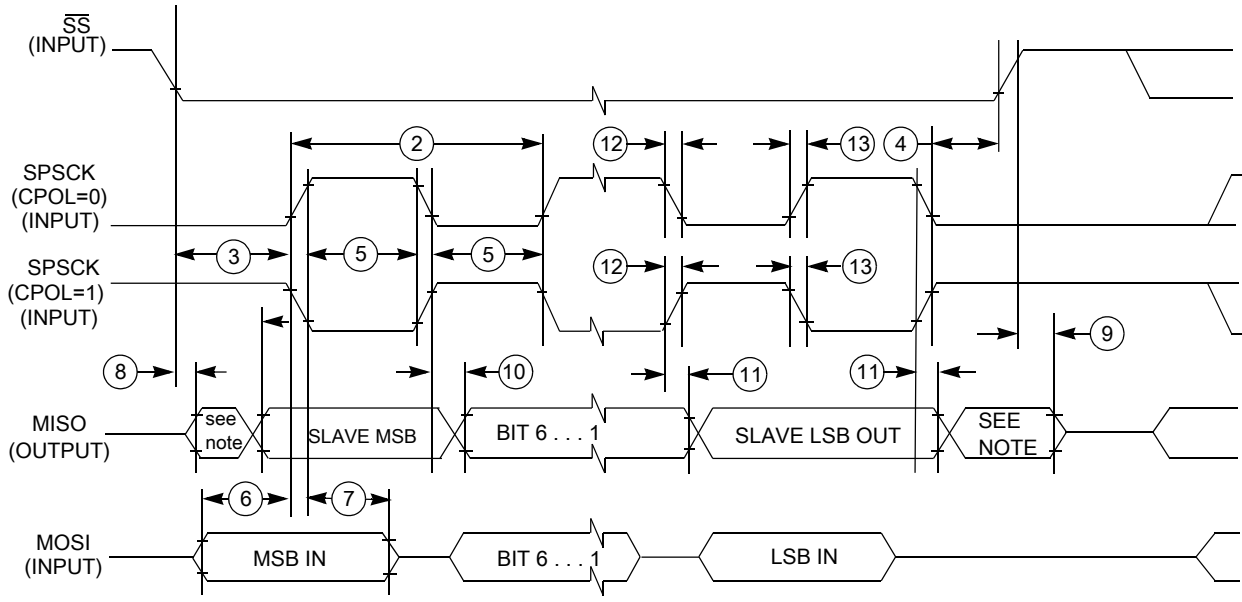

NOTE: Not defined

**Figure 13. SPI slave mode timing (CPHA = 0)**

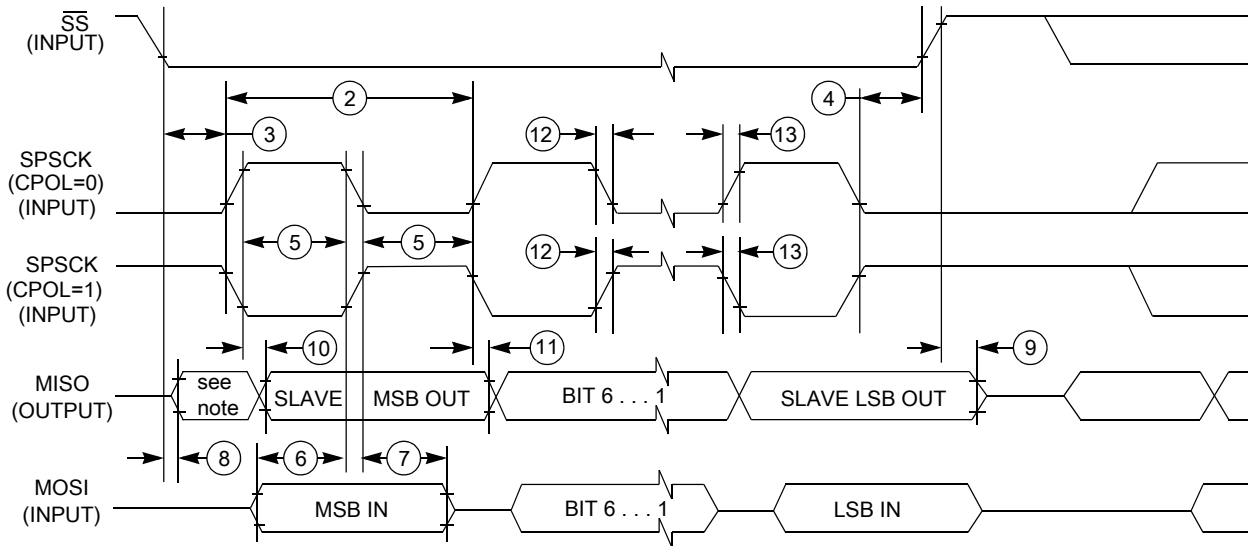

NOTE: Not defined

**Figure 14. SPI slave mode timing (CPHA = 1)**

### 3.8.2 Inter-Integrated Circuit Interface (I2C) timing

Table 32. I2C timing

Characteristic	Symbol	Standard Mode		Fast Mode		Unit
		Minimum	Maximum	Minimum	Maximum	
SCL Clock Frequency	$f_{SCL}$	0	100	0	400 <sup>1</sup>	kHz
Hold time (repeated) START condition. After this period, the first clock pulse is generated.	$t_{HD; STA}$	4	—	0.6	—	$\mu s$
LOW period of the SCL clock	$t_{LOW}$	4.7	—	1.3	—	$\mu s$
HIGH period of the SCL clock	$t_{HIGH}$	4	—	0.6	—	$\mu s$
Set-up time for a repeated START condition	$t_{SU; STA}$	4.7	—	0.6	—	$\mu s$
Data hold time for I <sup>2</sup> C bus devices	$t_{HD; DAT}$	0 <sup>2</sup>	3.45 <sup>3</sup>	0 <sup>4</sup>	0.9 <sup>2</sup>	$\mu s$
Data set-up time	$t_{SU; DAT}$	250 <sup>5</sup>	—	100 <sup>3, 6</sup>	—	ns
Rise time of SDA and SCL signals	$t_r$	—	1000	$20 + 0.1C_b$ <sup>7</sup>	300	ns
Fall time of SDA and SCL signals	$t_f$	—	300	$20 + 0.1C_b$ <sup>6</sup>	300	ns
Set-up time for STOP condition	$t_{SU; STO}$	4	—	0.6	—	$\mu s$
Bus free time between STOP and START condition	$t_{BUF}$	4.7	—	1.3	—	$\mu s$
Pulse width of spikes that must be suppressed by the input filter	$t_{SP}$	N/A	N/A	0	50	ns

1. The maximum SCL Clock Frequency in Fast mode with maximum bus loading can only be achieved when using the High drive pins (see [Voltage and current operating behaviors](#)) or when using the Normal drive pins and  $VDD \geq 2.7 V$
2. The master mode I<sup>2</sup>C deasserts ACK of an address byte simultaneously with the falling edge of SCL. If no slaves acknowledge this address byte, then a negative hold time can result, depending on the edge rates of the SDA and SCL lines.
3. The maximum  $t_{HD; DAT}$  must be met only if the device does not stretch the LOW period ( $t_{LOW}$ ) of the SCL signal.
4. Input signal Slew = 10 ns and Output Load = 50 pF
5. Set-up time in slave-transmitter mode is 1 IPBus clock period, if the TX FIFO is empty.
6. A Fast mode I<sup>2</sup>C bus device can be used in a Standard mode I2C bus system, but the requirement  $t_{SU; DAT} \geq 250 ns$  must then be met. This is automatically the case if the device does not stretch the LOW period of the SCL signal. If such a device does stretch the LOW period of the SCL signal, then it must output the next data bit to the SDA line  $t_{rmax} + t_{SU; DAT} = 1000 + 250 = 1250 ns$  (according to the Standard mode I<sup>2</sup>C bus specification) before the SCL line is released.
7.  $C_b$  = total capacitance of the one bus line in pF.

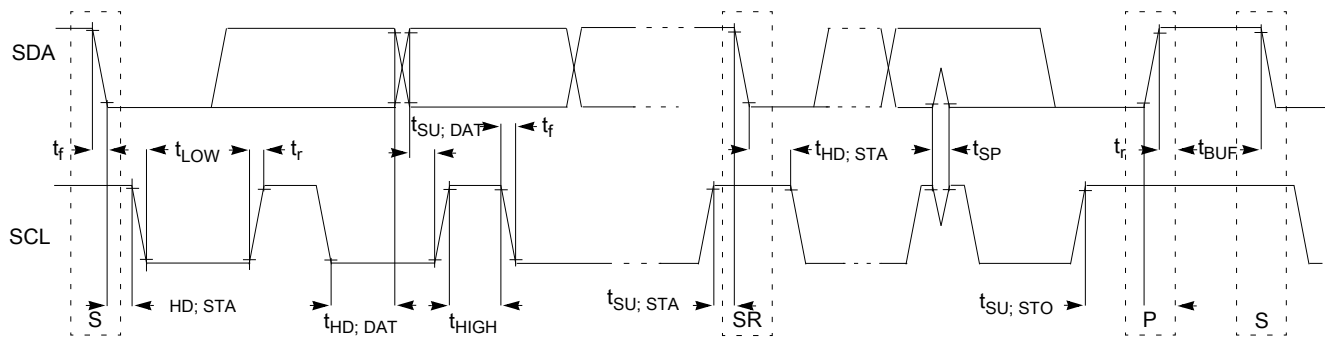

Figure 15. Timing definition for fast and standard mode devices on the I<sup>2</sup>C bus

### 3.8.3 UART

See [General switching specifications](#).

## 3.9 Human-machine interfaces (HMI)

### 3.9.1 LCD electrical characteristics

Table 33. LCD electricals

Symbol	Description	Min.	Typ.	Max.	Unit	Notes
$f_{\text{Frame}}$	LCD frame frequency <ul style="list-style-type: none"> <li>GCR[FFR]=0</li> <li>GCR[FFR]=1</li> </ul>	23.3	—	73.1	Hz	
		46.6	—	146.2	Hz	
$C_{\text{LCD}}$	LCD charge pump capacitance — nominal value	—	100	—	nF	1
$C_{\text{BYLCD}}$	LCD bypass capacitance — nominal value	—	100	—	nF	1
$C_{\text{Glass}}$	LCD glass capacitance	—	2000	8000	pF	2
$V_{\text{IREG}}$	$V_{\text{IREG}}$ <ul style="list-style-type: none"> <li>RVTRIM=0000</li> <li>RVTRIM=1000</li> <li>RVTRIM=0100</li> <li>RVTRIM=1100</li> <li>RVTRIM=0010</li> <li>RVTRIM=1010</li> <li>RVTRIM=0110</li> <li>RVTRIM=1110</li> <li>RVTRIM=0001</li> <li>RVTRIM=1001</li> <li>RVTRIM=0101</li> <li>RVTRIM=1101</li> <li>RVTRIM=0011</li> <li>RVTRIM=1011</li> <li>RVTRIM=0111</li> <li>RVTRIM=1111</li> </ul>	—	0.91	—	V	3
		—	0.92	—		
		—	0.93	—		
		—	0.94	—		
		—	0.96	—		
		—	0.97	—		
		—	0.98	—		
		—	0.99	—		
		—	1.01	—		
		—	1.02	—		
		—	1.03	—		
		—	1.05	—		
		—	1.06	—		
		—	1.07	—		
		—	1.08	—		
—	1.09	—				
$\Delta_{\text{RTRIM}}$	$V_{\text{IREG}}$ TRIM resolution	—	—	3.0	% $V_{\text{IREG}}$	

Table continues on the next page...

**Table 33. LCD electricals (continued)**

Symbol	Description	Min.	Typ.	Max.	Unit	Notes
$I_{VREG}$	$V_{IREG}$ current adder — $RVEN = 1$	—	1	—	$\mu A$	4
$I_{RBIAS}$	RBIAS current adder					
	<ul style="list-style-type: none"> <li>LADJ = 10 or 11 — High load (LCD glass capacitance <math>\leq 8000</math> pF)</li> <li>LADJ = 00 or 01 — Low load (LCD glass capacitance <math>\leq 2000</math> pF)</li> </ul>	—	10	—	$\mu A$	
$R_{RBIAS}$	RBIAS resistor values					
	<ul style="list-style-type: none"> <li>LADJ = 10 or 11 — High load (LCD glass capacitance <math>\leq 8000</math> pF)</li> <li>LADJ = 00 or 01 — Low load (LCD glass capacitance <math>\leq 2000</math> pF)</li> </ul>	—	0.28	—	$M\Omega$	
VLL1	VLL1 voltage	—	—	$V_{IREG}$	V	5
VLL2	VLL2 voltage	—	—	$2 \times V_{IREG}$	V	5
VLL3	VLL3 voltage	—	—	$3 \times V_{IREG}$	V	5
VLL1	VLL1 voltage	—	—	$V_{DDA} / 3$	V	6
VLL2	VLL2 voltage	—	—	$V_{DDA} / 1.5$	V	6
VLL3	VLL3 voltage	—	—	$V_{DDA}$	V	6

- The actual value used could vary with tolerance.
- For highest glass capacitance values, LCD\_GCR[LADJ] should be configured as specified in the LCD Controller chapter within the device's reference manual.
- $V_{IREG}$  maximum should never be externally driven to any level other than  $V_{DD} - 0.15$  V
- 2000 pF load LCD, 32 Hz frame frequency
- VLL1, VLL2 and VLL3 are a function of  $V_{IREG}$  only when the regulator is enabled (GCR[RVEN]=1) and the charge pump is enabled (GCR[CPSEL]=1).
- VLL1, VLL2 and VLL3 are a function of  $V_{DDA}$  only under either of the following conditions:
  - The charge pump is enabled (GCR[CPSEL]=1), the regulator is disabled (GCR[RVEN]=0), and  $VLL3 = V_{DDA}$  through the internal power switch (GCR[VSUPPLY]=0).
  - The resistor bias string is enabled (GCR[CPSEL]=0), the regulator is disabled (GCR[RVEN]=0), and VLL3 is connected to  $V_{DDA}$  externally (GCR[VSUPPLY]=1).

## 4 Dimensions

### 4.1 Obtaining package dimensions

Package dimensions are provided in package drawings.

To find a package drawing, go to [freescale.com](http://freescale.com) and perform a keyword search for the drawing's document number:

If you want the drawing for this package	Then use this document number
64-pin LQFP	98ASS23234W
100-pin LQFP	98ASS23308W

## 5 Pinout

### 5.1 KL34 Signal Multiplexing and Pin Assignments

The following table shows the signals available on each pin and the locations of these pins on the devices supported by this document. The Port Control Module is responsible for selecting which ALT functionality is available on each pin.

100 LQFP	64 LQFP	Pin Name	Default	ALT0	ALT1	ALT2	ALT3	ALT4	ALT5	ALT6	ALT7	EzPort
1	1	PTE0	DISABLED	LCD_P48	PTE0	SPI1_MISO	UART1_TX	RTC_CLKOUT	CMP0_OUT	I2C1_SDA	LCD_P48	
2	2	PTE1	DISABLED	LCD_P49	PTE1	SPI1_MOSI	UART1_RX		SPI1_MISO	I2C1_SCL	LCD_P49	
3	—	PTE2	DISABLED	LCD_P50	PTE2	SPI1_SCK					LCD_P50	
4	—	PTE3	DISABLED	LCD_P51	PTE3	SPI1_MISO			SPI1_MOSI		LCD_P51	
5	—	PTE4	DISABLED	LCD_P52	PTE4	SPI1_PCS0					LCD_P52	
6	—	PTE5	DISABLED	LCD_P53	PTE5						LCD_P53	
7	—	PTE6	DISABLED	LCD_P54	PTE6						LCD_P54	
8	3	VDD	VDD	VDD								
9	4	VSS	VSS	VSS								
10	—	NC	NC	NC								
11	—	NC	NC	NC								
12	—	NC	NC	NC								
13	—	NC	NC	NC								
14	5	PTE16	LCD_P55/ ADC0_SE1	LCD_P55/ ADC0_SE1	PTE16	SPI0_PCS0	UART2_TX	TPM_CLKIN0			LCD_P55	
15	6	PTE17	LCD_P56/ ADC0_SE5a	LCD_P56/ ADC0_SE5a	PTE17	SPI0_SCK	UART2_RX	TPM_CLKIN1		LPTMR0_ALT3	LCD_P56	
16	7	PTE18	LCD_P57/ ADC0_SE2	LCD_P57/ ADC0_SE2	PTE18	SPI0_MOSI		I2C0_SDA	SPI0_MISO		LCD_P57	
17	8	PTE19	LCD_P58/ ADC0_SE6a	LCD_P58/ ADC0_SE6a	PTE19	SPI0_MISO		I2C0_SCL	SPI0_MOSI		LCD_P58	
18	9	PTE20	LCD_P59/ ADC0_SE0	LCD_P59/ ADC0_SE0	PTE20		TPM1_CH0	UART0_TX			LCD_P59	
19	10	PTE21	LCD_P60/ ADC0_SE4a	LCD_P60/ ADC0_SE4a	PTE21		TPM1_CH1	UART0_RX			LCD_P60	



## Pinout

100 LQFP	64 LQFP	Pin Name	Default	ALT0	ALT1	ALT2	ALT3	ALT4	ALT5	ALT6	ALT7	EzPort
20	11	PTE22	ADC0_SE3	ADC0_SE3	PTE22		TPM2_CH0	UART2_TX				
21	12	PTE23	ADC0_SE7a	ADC0_SE7a	PTE23		TPM2_CH1	UART2_RX				
22	13	VDDA	VDDA	VDDA								
23	14	VREFH	VREFH	VREFH								
24	15	VREFL	VREFL	VREFL								
25	16	VSSA	VSSA	VSSA								
26	17	PTE29	CMP0_IN5/ ADC0_SE4b	CMP0_IN5/ ADC0_SE4b	PTE29		TPM0_CH2	TPM_ CLKIN0				
27	18	PTE30	ADC0_SE23/ CMP0_IN4	ADC0_SE23/ CMP0_IN4	PTE30		TPM0_CH3	TPM_ CLKIN1				
28	19	PTE31	DISABLED		PTE31		TPM0_CH4					
29	—	VSS	VSS	VSS								
30	—	VDD	VDD	VDD								
31	20	PTE24	DISABLED		PTE24		TPM0_CH0		I2C0_SCL			
32	21	PTE25	DISABLED		PTE25		TPM0_CH1		I2C0_SDA			
33	—	PTE26	DISABLED		PTE26		TPM0_CH5			RTC_ CLKOUT		
34	22	PTA0	SWD_CLK		PTA0		TPM0_CH5				SWD_CLK	
35	23	PTA1	DISABLED		PTA1	UART0_RX	TPM2_CH0					
36	24	PTA2	DISABLED		PTA2	UART0_TX	TPM2_CH1					
37	25	PTA3	SWD_DIO		PTA3	I2C1_SCL	TPM0_CH0				SWD_DIO	
38	26	PTA4	NMI_b		PTA4	I2C1_SDA	TPM0_CH1				NMI_b	
39	27	PTA5	DISABLED		PTA5		TPM0_CH2					
40	—	PTA6	DISABLED		PTA6		TPM0_CH3					
41	—	PTA7	DISABLED		PTA7		TPM0_CH4					
42	28	PTA12	DISABLED		PTA12		TPM1_CH0					
43	29	PTA13	DISABLED		PTA13		TPM1_CH1					
44	—	PTA14	DISABLED		PTA14	SPI0_PCS0	UART0_TX					
45	—	PTA15	DISABLED		PTA15	SPI0_SCK	UART0_RX					
46	—	PTA16	DISABLED		PTA16	SPI0_MOSI			SPI0_MISO			
47	—	PTA17	DISABLED		PTA17	SPI0_MISO			SPI0_MISO			
48	30	VDD	VDD	VDD								
49	31	VSS	VSS	VSS								
50	32	PTA18	EXTAL0	EXTAL0	PTA18		UART1_RX	TPM_ CLKIN0				
51	33	PTA19	XTAL0	XTAL0	PTA19		UART1_TX	TPM_ CLKIN1		LPTMR0_ ALT1		
52	34	PTA20	RESET_b		PTA20						RESET_b	
53	35	PTB0/ LLWU_P5	LCD_P0/ ADC0_SE8	LCD_P0/ ADC0_SE8	PTB0/ LLWU_P5	I2C0_SCL	TPM1_CH0				LCD_P0	
54	36	PTB1	LCD_P1/ ADC0_SE9	LCD_P1/ ADC0_SE9	PTB1	I2C0_SDA	TPM1_CH1				LCD_P1	

100 LQFP	64 LQFP	Pin Name	Default	ALT0	ALT1	ALT2	ALT3	ALT4	ALT5	ALT6	ALT7	EzPort
55	37	PTB2	LCD_P2/ ADC0_SE12	LCD_P2/ ADC0_SE12	PTB2	I2C0_SCL	TPM2_CH0				LCD_P2	
56	38	PTB3	LCD_P3/ ADC0_SE13	LCD_P3/ ADC0_SE13	PTB3	I2C0_SDA	TPM2_CH1				LCD_P3	
57	—	PTB7	LCD_P7	LCD_P7	PTB7						LCD_P7	
58	—	PTB8	LCD_P8	LCD_P8	PTB8	SPI1_PCS0	EXTRG_IN				LCD_P8	
59	—	PTB9	LCD_P9	LCD_P9	PTB9	SPI1_SCK					LCD_P9	
60	—	PTB10	LCD_P10	LCD_P10	PTB10	SPI1_PCS0					LCD_P10	
61	—	PTB11	LCD_P11	LCD_P11	PTB11	SPI1_SCK					LCD_P11	
62	39	PTB16	LCD_P12	LCD_P12	PTB16	SPI1_MOSI	UART0_RX	TPM_CLKIN0	SPI1_MISO		LCD_P12	
63	40	PTB17	LCD_P13	LCD_P13	PTB17	SPI1_MISO	UART0_TX	TPM_CLKIN1	SPI1_MOSI		LCD_P13	
64	41	PTB18	LCD_P14	LCD_P14	PTB18		TPM2_CH0				LCD_P14	
65	42	PTB19	LCD_P15	LCD_P15	PTB19		TPM2_CH1				LCD_P15	
66	—	PTB20	LCD_P16	LCD_P16	PTB20					CMP0_OUT	LCD_P16	
67	—	PTB21	LCD_P17	LCD_P17	PTB21						LCD_P17	
68	—	PTB22	LCD_P18	LCD_P18	PTB22						LCD_P18	
69	—	PTB23	LCD_P19	LCD_P19	PTB23						LCD_P19	
70	43	PTC0	LCD_P20/ ADC0_SE14	LCD_P20/ ADC0_SE14	PTC0		EXTRG_IN		CMP0_OUT		LCD_P20	
71	44	PTC1/ LLWU_P6/ RTC_CLKIN	LCD_P21/ ADC0_SE15	LCD_P21/ ADC0_SE15	PTC1/ LLWU_P6/ RTC_CLKIN	I2C1_SCL		TPM0_CH0			LCD_P21	
72	45	PTC2	LCD_P22/ ADC0_SE11	LCD_P22/ ADC0_SE11	PTC2	I2C1_SDA		TPM0_CH1			LCD_P22	
73	46	PTC3/ LLWU_P7	LCD_P23	LCD_P23	PTC3/ LLWU_P7		UART1_RX	TPM0_CH2	CLKOUT		LCD_P23	
74	47	VSS	VSS	VSS								
75	48	VLL3	VLL3	VLL3								
76	49	VLL2	VLL2	VLL2/ LCD_P4	PTC20						LCD_P4	
77	50	VLL1	VLL1	VLL1/ LCD_P5	PTC21						LCD_P5	
78	51	VCAP2	VCAP2	VCAP2/ LCD_P6	PTC22						LCD_P6	
79	52	VCAP1	VCAP1	VCAP1/ LCD_P39	PTC23						LCD_P39	
80	53	PTC4/ LLWU_P8	LCD_P24	LCD_P24	PTC4/ LLWU_P8	SPI0_PCS0	UART1_TX	TPM0_CH3			LCD_P24	
81	54	PTC5/ LLWU_P9	LCD_P25	LCD_P25	PTC5/ LLWU_P9	SPI0_SCK	LPTMR0_ALT2			CMP0_OUT	LCD_P25	
82	55	PTC6/ LLWU_P10	LCD_P26/ CMP0_IN0	LCD_P26/ CMP0_IN0	PTC6/ LLWU_P10	SPI0_MOSI	EXTRG_IN		SPI0_MISO		LCD_P26	

100 LQFP	64 LQFP	Pin Name	Default	ALT0	ALT1	ALT2	ALT3	ALT4	ALT5	ALT6	ALT7	EzPort
83	56	PTC7	LCD_P27/ CMP0_IN1	LCD_P27/ CMP0_IN1	PTC7	SPI0_MISO			SPI0_MOSI		LCD_P27	
84	—	PTC8	LCD_P28/ CMP0_IN2	LCD_P28/ CMP0_IN2	PTC8	I2C0_SCL	TPM0_CH4				LCD_P28	
85	—	PTC9	LCD_P29/ CMP0_IN3	LCD_P29/ CMP0_IN3	PTC9	I2C0_SDA	TPM0_CH5				LCD_P29	
86	—	PTC10	LCD_P30	LCD_P30	PTC10	I2C1_SCL					LCD_P30	
87	—	PTC11	LCD_P31	LCD_P31	PTC11	I2C1_SDA					LCD_P31	
88	—	PTC12	LCD_P32	LCD_P32	PTC12			TPM_ CLKIN0			LCD_P32	
89	—	PTC13	LCD_P33	LCD_P33	PTC13			TPM_ CLKIN1			LCD_P33	
90	—	PTC16	LCD_P36	LCD_P36	PTC16						LCD_P36	
91	—	PTC17	LCD_P37	LCD_P37	PTC17						LCD_P37	
92	—	PTC18	LCD_P38	LCD_P38	PTC18						LCD_P38	
93	57	PTD0	LCD_P40	LCD_P40	PTD0	SPI0_PCS0		TPM0_CH0			LCD_P40	
94	58	PTD1	LCD_P41/ ADC0_SE5b	LCD_P41/ ADC0_SE5b	PTD1	SPI0_SCK		TPM0_CH1			LCD_P41	
95	59	PTD2	LCD_P42	LCD_P42	PTD2	SPI0_MOSI	UART2_RX	TPM0_CH2	SPI0_MISO		LCD_P42	
96	60	PTD3	LCD_P43	LCD_P43	PTD3	SPI0_MISO	UART2_TX	TPM0_CH3	SPI0_MOSI		LCD_P43	
97	61	PTD4/ LLWU_P14	LCD_P44	LCD_P44	PTD4/ LLWU_P14	SPI1_PCS0	UART2_RX	TPM0_CH4			LCD_P44	
98	62	PTD5	LCD_P45/ ADC0_SE6b	LCD_P45/ ADC0_SE6b	PTD5	SPI1_SCK	UART2_TX	TPM0_CH5			LCD_P45	
99	63	PTD6/ LLWU_P15	LCD_P46/ ADC0_SE7b	LCD_P46/ ADC0_SE7b	PTD6/ LLWU_P15	SPI1_MOSI	UART0_RX		SPI1_MISO		LCD_P46	
100	64	PTD7	LCD_P47	LCD_P47	PTD7	SPI1_MISO	UART0_TX		SPI1_MOSI		LCD_P47	
100	64											

## 5.2 KL34 pinouts

The following figures show the pinout diagrams for the devices supported by this document. Many signals may be multiplexed onto a single pin. To determine what signals can be used on which pin, see [KL34 Signal Multiplexing and Pin Assignments](#).

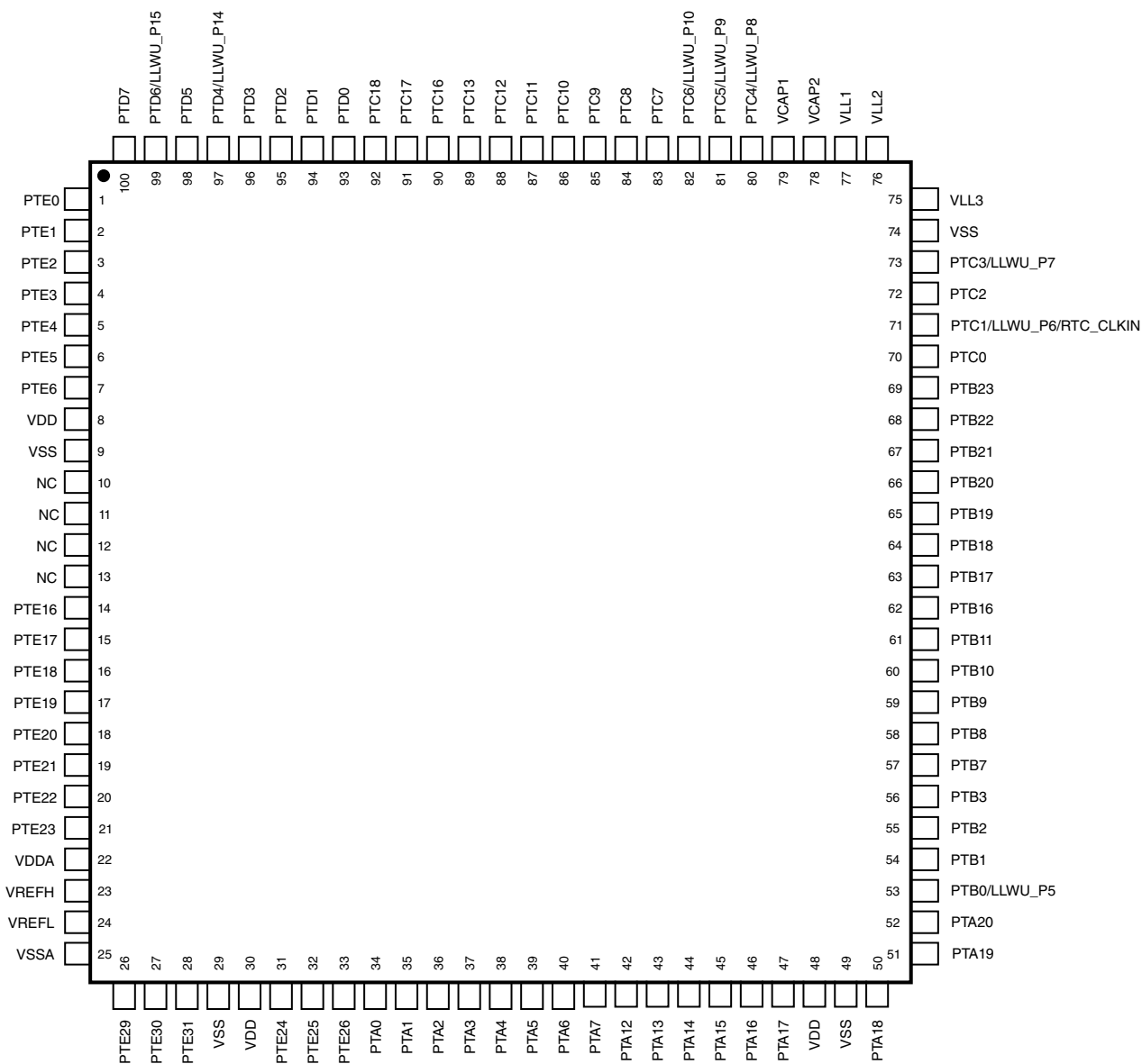

Figure 16. KL34 100-pin LQFP pinout diagram

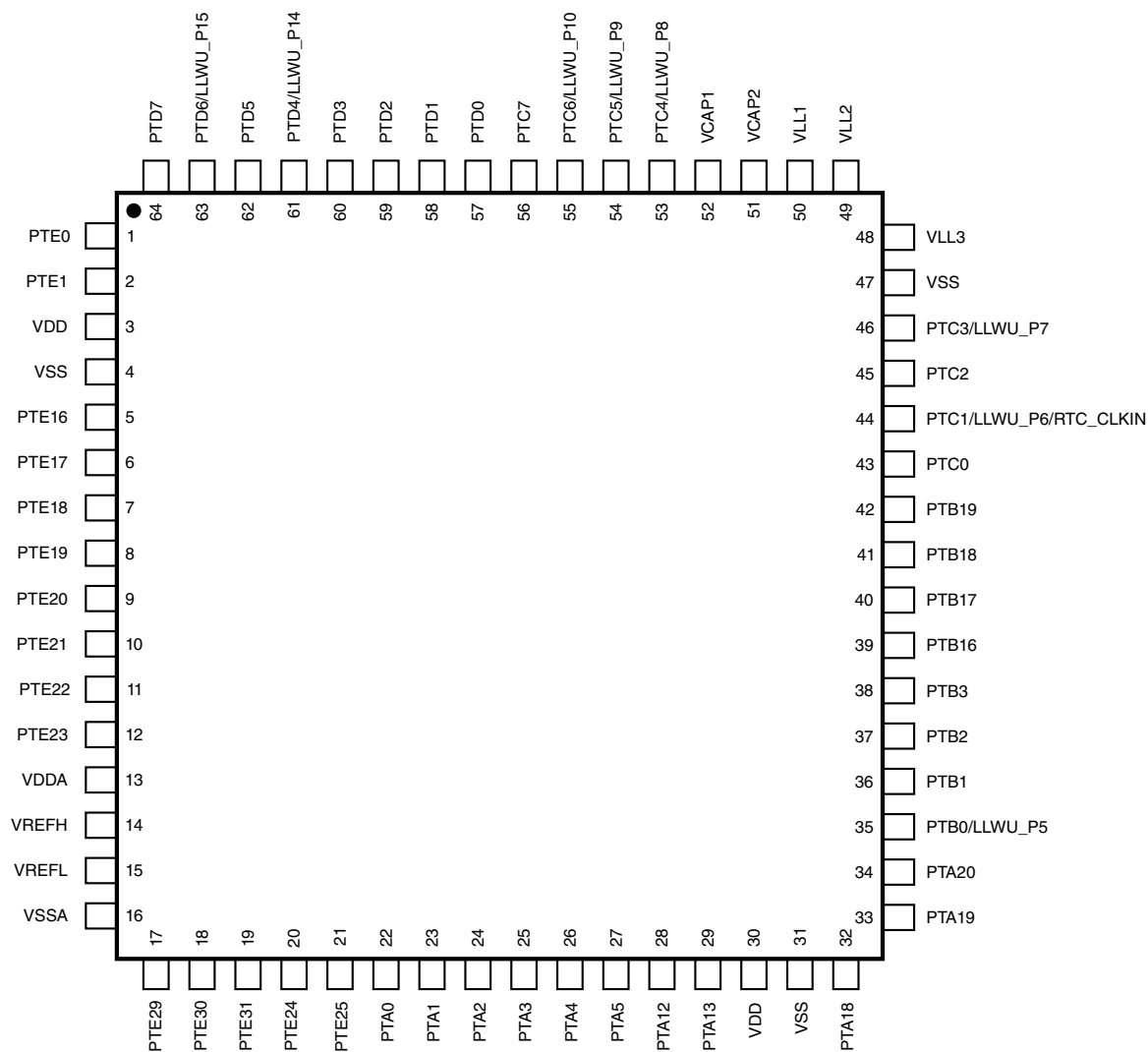

Figure 17. KL34 64-pin LQFP pinout diagram

## 6 Ordering parts

### 6.1 Determining valid orderable parts

Valid orderable part numbers are provided on the web. To determine the orderable part numbers for this device, go to [freescale.com](http://freescale.com) and perform a part number search for the following device numbers: PKL34 and MKL34

## 7 Part identification

### 7.1 Description

Part numbers for the chip have fields that identify the specific part. You can use the values of these fields to determine the specific part you have received.

### 7.2 Format

Part numbers for this device have the following format:

Q KL## A FFF R T PP CC N

### 7.3 Fields

This table lists the possible values for each field in the part number (not all combinations are valid):

**Table 34. Part number fields descriptions**

Field	Description	Values
Q	Qualification status	<ul style="list-style-type: none"> <li>M = Fully qualified, general market flow</li> <li>P = Prequalification</li> </ul>
KL##	Kinetis family	<ul style="list-style-type: none"> <li>KL34</li> </ul>
A	Key attribute	<ul style="list-style-type: none"> <li>Z = Cortex-M0+</li> </ul>
FFF	Program flash memory size	<ul style="list-style-type: none"> <li>64 = 64 KB</li> </ul>
R	Silicon revision	<ul style="list-style-type: none"> <li>(Blank) = Main</li> <li>A = Revision after main</li> </ul>
T	Temperature range (°C)	<ul style="list-style-type: none"> <li>V = -40 to 105</li> </ul>
PP	Package identifier	<ul style="list-style-type: none"> <li>LH = 64 LQFP (10 mm x 10 mm)</li> <li>LL = 100 LQFP (14 mm x 14 mm)</li> </ul>
CC	Maximum CPU frequency (MHz)	<ul style="list-style-type: none"> <li>4 = 48 MHz</li> </ul>
N	Packaging type	<ul style="list-style-type: none"> <li>R = Tape and reel</li> </ul>

## 7.4 Example

This is an example part number:

MKL34Z64VLL4

## 8 Terminology and guidelines

### 8.1 Definition: Operating requirement

An *operating requirement* is a specified value or range of values for a technical characteristic that you must guarantee during operation to avoid incorrect operation and possibly decreasing the useful life of the chip.

#### 8.1.1 Example

This is an example of an operating requirement:

Symbol	Description	Min.	Max.	Unit
V <sub>DD</sub>	1.0 V core supply voltage	0.9	1.1	V

### 8.2 Definition: Operating behavior

Unless otherwise specified, an *operating behavior* is a specified value or range of values for a technical characteristic that are guaranteed during operation if you meet the operating requirements and any other specified conditions.

### 8.3 Definition: Attribute

An *attribute* is a specified value or range of values for a technical characteristic that are guaranteed, regardless of whether you meet the operating requirements.

### 8.3.1 Example

This is an example of an attribute:

Symbol	Description	Min.	Max.	Unit
CIN_D	Input capacitance: digital pins	—	7	pF

## 8.4 Definition: Rating

A *rating* is a minimum or maximum value of a technical characteristic that, if exceeded, may cause permanent chip failure:

- *Operating ratings* apply during operation of the chip.
- *Handling ratings* apply when the chip is not powered.

### 8.4.1 Example

This is an example of an operating rating:

Symbol	Description	Min.	Max.	Unit
V <sub>DD</sub>	1.0 V core supply voltage	−0.3	1.2	V

## 8.5 Result of exceeding a rating

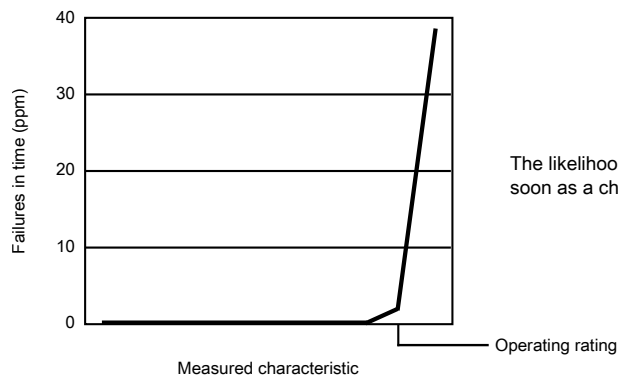

The likelihood of permanent chip failure increases rapidly as soon as a characteristic begins to exceed one of its operating ratings.

## 8.6 Relationship between ratings and operating requirements

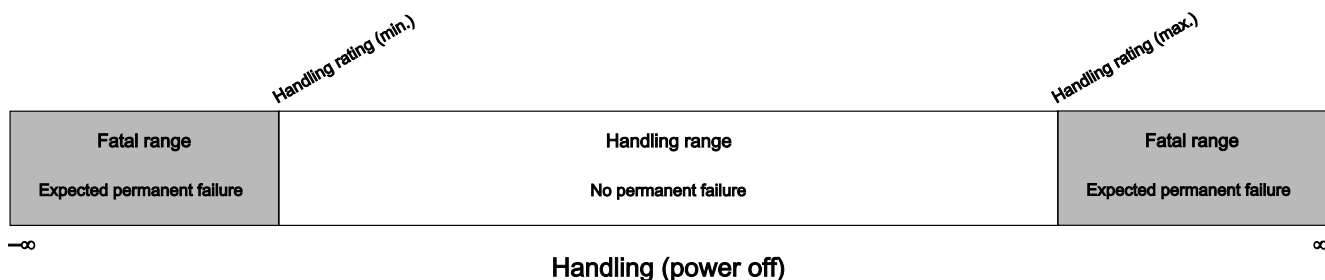
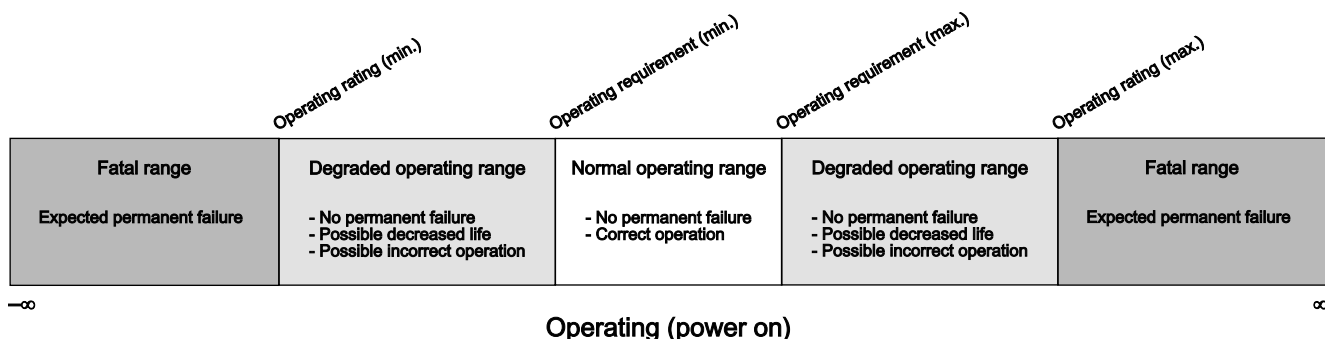

## 8.7 Guidelines for ratings and operating requirements

Follow these guidelines for ratings and operating requirements:

- Never exceed any of the chip’s ratings.
- During normal operation, don’t exceed any of the chip’s operating requirements.
- If you must exceed an operating requirement at times other than during normal operation (for example, during power sequencing), limit the duration as much as possible.

## 8.8 Definition: Typical value

A *typical value* is a specified value for a technical characteristic that:

- Lies within the range of values specified by the operating behavior
- Given the typical manufacturing process, is representative of that characteristic during operation when you meet the typical-value conditions or other specified conditions

Typical values are provided as design guidelines and are neither tested nor guaranteed.

### 8.8.1 Example 1

This is an example of an operating behavior that includes a typical value:

Symbol	Description	Min.	Typ.	Max.	Unit
$I_{WP}$	Digital I/O weak pullup/pulldown current	10	70	130	$\mu\text{A}$

### 8.8.2 Example 2

This is an example of a chart that shows typical values for various voltage and temperature conditions:

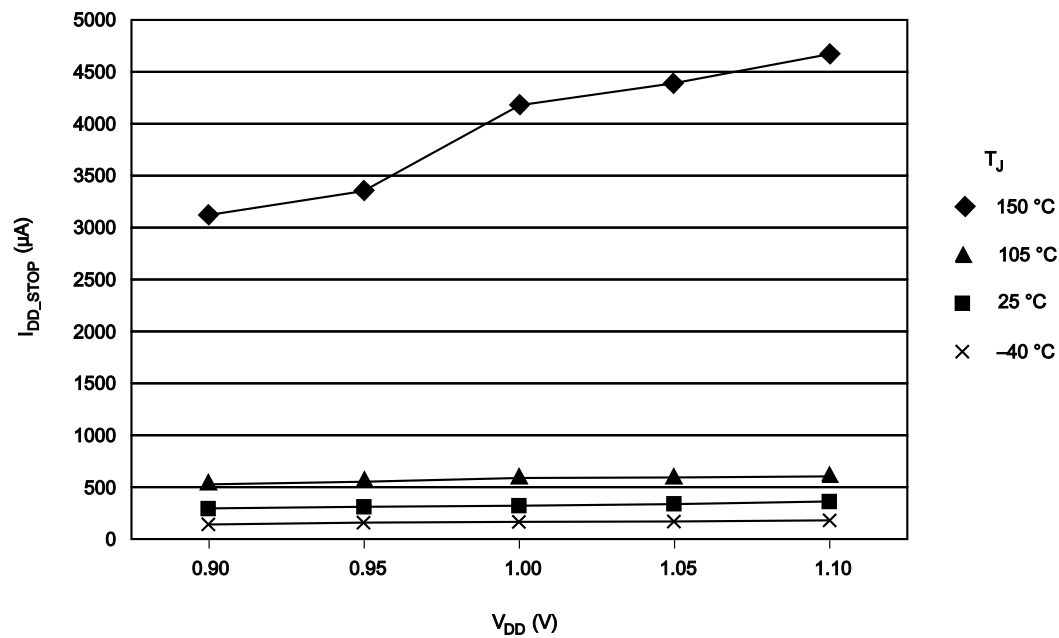

## 8.9 Typical value conditions

Typical values assume you meet the following conditions (or other conditions as specified):

**Table 35. Typical value conditions**

Symbol	Description	Value	Unit
T <sub>A</sub>	Ambient temperature	25	°C
V <sub>DD</sub>	3.3 V supply voltage	3.3	V

## 9 Revision history

The following table provides a revision history for this document.

**Table 36. Revision history**

Rev. No.	Date	Substantial Changes
3	3/2014	<ul style="list-style-type: none"> <li>Updated the front page and restructured the chapters</li> <li>Updated <a href="#">Voltage and current operating behaviors</a></li> <li>Updated <a href="#">EMC radiated emissions operating behaviors</a></li> <li>Updated <a href="#">Power mode transition operating behaviors</a></li> <li>Updated <a href="#">Capacitance attributes</a></li> <li>Updated footnote in the <a href="#">Device clock specifications</a></li> <li>Added V<sub>REFH</sub> and V<sub>REFL</sub> in the <a href="#">12-bit ADC electrical characteristics</a></li> <li>Updated footnote to the V<sub>DACR</sub> in the <a href="#">12-bit DAC operating requirements</a></li> <li>Added <a href="#">Inter-Integrated Circuit Interface (I2C) timing</a></li> </ul>
4	5/2014	<ul style="list-style-type: none"> <li>Updated <a href="#">Power consumption operating behaviors</a></li> <li>Updated <a href="#">Definition: Operating behavior</a></li> </ul>
5	08/2014	<ul style="list-style-type: none"> <li>Updated related source in the front page</li> <li>Updated <a href="#">Power consumption operating behaviors</a></li> </ul>

**How to Reach Us:**

**Home Page:**

[freescale.com](http://freescale.com)

**Web Support:**

[freescale.com/support](http://freescale.com/support)

Information in this document is provided solely to enable system and software implementers to use Freescale products. There are no express or implied copyright licenses granted hereunder to design or fabricate any integrated circuits based on the information in this document. Freescale reserves the right to make changes without further notice to any products herein.

Freescale makes no warranty, representation, or guarantee regarding the suitability of its products for any particular purpose, nor does Freescale assume any liability arising out of the application or use of any product or circuit, and specifically disclaims any and all liability, including without limitation consequential or incidental damages. "Typical" parameters that may be provided in Freescale data sheets and/or specifications can and do vary in different applications, and actual performance may vary over time. All operating parameters, including "typicals," must be validated for each customer application by customer's technical experts. Freescale does not convey any license under its patent rights nor the rights of others. Freescale sells products pursuant to standard terms and conditions of sale, which can be found at the following address: [freescale.com/SalesTermsandConditions](http://freescale.com/SalesTermsandConditions).

Freescale, Freescale logo, Energy Efficient Solutions logo, and Kinetis are trademarks of Freescale Semiconductor, Inc., Reg. U.S. Pat. & Tm. Off. All other product or service names are the property of their respective owners. ARM and Cortex are registered trademarks of ARM Limited (or its subsidiaries) in the EU and/or elsewhere. All rights reserved.

© 2012-2014 Freescale Semiconductor, Inc.

## Looking for pricing, stock, or lifecycle information?

Click below to explore more details on WIN SOURCE:

 [View MKL34Z64VLH4 on WIN SOURCE](#)

 [NXP / Nexperia Information](#)

## Optimize Your Supply Chain with WIN SOURCE Solutions

-  Global Sourcing Solution
-  Obsolete Management
-  Cost Control Management
-  Shortage Management
-  Alternative Solution
-  Excess Inventory Management