



**THE DATASHEET OF  
MCF51JF64VLF**



# MCF51JF128

## MCF51JF128

Supports the MCF51JF128VLH,  
MCF51JF128VHS, MCF51JF64VLF,  
MCF51JF64VHS, MCF51JF32VHS,  
MCF51JF32VFM

### Features

- Operating characteristics
  - Voltage range: 1.71 V to 3.6 V
  - Flash write voltage range: 1.71 V to 3.6 V
  - Temperature range (ambient): -40°C to 105°C
- Core
  - Up to 50 MHz V1 ColdFire CPU
  - Dhrystone 2.1 performance: 1.10 DMIPS per MHz when executing from internal RAM, 0.99 DMIPS per MHz when executing from flash memory
- System
  - DMA controller with four programmable channels
  - Integrated ColdFire DEBUG\_Rev\_B+ interface with single-wire BDM connection
- Power management
  - 10 low power modes to provide power optimization based on application requirements
  - Low-leakage wakeup unit (LLWU)
  - Voltage regulator (VREG)
- Clocks
  - Crystal oscillators (two, each with range options): 1 kHz to 32 kHz (low), 1 MHz to 8 MHz (medium), 8 MHz to 32 MHz (high)
  - Multipurpose clock generator (MCG)
- Memories and memory interfaces
  - Flash memory, FlexNVM, FlexRAM, and RAM
  - Serial programming interface (EzPort)
  - Mini-FlexBus external bus interface
- Security and integrity
  - Hardware CRC module to support fast cyclic redundancy checks
  - Hardware random number generator (RNGB)
  - Hardware cryptographic acceleration unit (CAU)
  - 128-bit unique identification (ID) number per chip
- Analog
  - 12-bit SAR ADC
  - 12-bit DAC
  - Analog comparator (CMP) containing a 6-bit DAC and programmable reference input
  - Voltage reference (VREF)
- Timers
  - Programmable delay block (PDB)
  - Motor control/general purpose/PWM timers (FTM)
  - 16-bit low-power timers (LPTMRs)
  - 16-bit modulo timer (MTIM)
  - Carrier modulator transmitter (CMT)
- Communication interfaces
  - UARTs with Smart Card support and FIFO
  - SPI modules, one with FIFO
  - Inter-Integrated Circuit (I2C) modules
  - USB full/low speed On-the-Go controller with on-chip transceiver
  - Integrated Interchip Sound (I2S) / Serial Audio Interface (SAI) to support full-duplex serial interfaces with frame sync such as AC97 and CODEC
- Human-machine interface
  - Up to 48 EGPIO pins
  - Up to 16 rapid general purpose I/O (RGPIO) pins
  - Low-power hardware touch sensor interface (TSI)
  - Interrupt request pin (IRQ)

# Table of Contents

1	Ordering parts.....	3	5.4.1	Thermal operating requirements.....	20
1.1	Determining valid orderable parts.....	3	5.4.2	Thermal attributes.....	20
2	Part identification.....	3	6	Peripheral operating requirements and behaviors.....	21
2.1	Description.....	3	6.1	Core modules.....	21
2.2	Format.....	3	6.1.1	Debug specifications.....	21
2.3	Fields.....	3	6.2	System modules.....	21
2.4	Example.....	4	6.3	Clock modules.....	21
3	Terminology and guidelines.....	4	6.3.1	MCG specifications.....	21
3.1	Definition: Operating requirement.....	4	6.3.2	Oscillator electrical specifications.....	23
3.2	Definition: Operating behavior.....	4	6.4	Memories and memory interfaces.....	26
3.3	Definition: Attribute.....	5	6.4.1	Flash electrical specifications.....	26
3.4	Definition: Rating.....	5	6.4.2	EzPort Switching Specifications.....	29
3.5	Result of exceeding a rating.....	6	6.4.3	Mini-Flexbus Switching Specifications.....	30
3.6	Relationship between ratings and operating requirements.....	6	6.5	Security and integrity modules.....	32
3.7	Guidelines for ratings and operating requirements.....	6	6.6	Analog.....	33
3.8	Definition: Typical value.....	7	6.6.1	ADC electrical specifications.....	33
4	Ratings.....	8	6.6.2	CMP and 6-bit DAC electrical specifications.....	36
4.1	Thermal handling ratings.....	8	6.6.3	12-bit DAC electrical characteristics.....	38
4.2	Moisture handling ratings.....	8	6.6.4	Voltage reference electrical specifications.....	41
4.3	ESD handling ratings.....	8	6.7	Timers.....	42
4.4	Voltage and current operating ratings.....	8	6.8	Communication interfaces.....	42
5	General.....	9	6.8.1	USB electrical specifications.....	42
5.1	Typical Value Conditions.....	9	6.8.2	USB DCD electrical specifications.....	43
5.2	Nonswitching electrical specifications.....	9	6.8.3	USB VREG electrical specifications.....	43
5.2.1	Voltage and Current Operating Requirements.....	9	6.8.4	SPI switching specifications.....	44
5.2.2	LVD and POR operating requirements.....	10	6.8.5	I2S/SAI Switching Specifications.....	47
5.2.3	Voltage and current operating behaviors.....	11	6.9	Human-machine interfaces (HMI).....	49
5.2.4	Power mode transition operating behaviors.....	12	6.9.1	TSI electrical specifications.....	49
5.2.5	Power consumption operating behaviors.....	13	7	Dimensions.....	50
5.2.6	EMC radiated emissions operating behaviors.....	16	7.1	Obtaining package dimensions.....	50
5.2.7	Designing with radiated emissions in mind.....	17	8	Pinout.....	50
5.2.8	Capacitance attributes.....	17	8.1	Signal Multiplexing and Pin Assignments.....	50
5.3	Switching electrical specifications.....	17	8.2	Pinout diagrams.....	53
5.3.1	General Switching Specifications.....	18	8.3	Module-by-module signals.....	57
5.4	Thermal specifications.....	20	9	Revision History.....	67

# 1 Ordering parts

## 1.1 Determining valid orderable parts

Valid orderable part numbers are provided on the web. To determine the orderable part numbers for this device:

1. Go to [www.freescale.com](http://www.freescale.com).
2. Perform a part number search for the following partial device numbers: PCF51JF and MCF51JF.

# 2 Part identification

## 2.1 Description

Part numbers for the chip have fields that identify the specific part. You can use the values of these fields to determine the specific part you have received.

## 2.2 Format

Part numbers for this device have the following format:

Q CCCC DD MMM T PP

## 2.3 Fields

This table lists the possible values for each field in the part number (not all combinations are valid):

Field	Description	Values
Q	Qualification status	<ul style="list-style-type: none"> <li>• M = Fully qualified, general market flow</li> <li>• P = Prequalification</li> </ul>
CCCC	Core code	CF51 = ColdFire V1
DD	Device number	JF, JU, QF, QH, QM, QU
MMM	Memory size (program flash memory) <sup>1</sup>	<ul style="list-style-type: none"> <li>• 32 = 32 KB</li> </ul>

*Table continues on the next page...*

## Terminology and guidelines

Field	Description	Values
		<ul style="list-style-type: none"> <li>• 64 = 64 KB</li> <li>• 128 = 128 KB</li> </ul>
T	Temperature range, ambient (°C)	V = -40 to 105
PP	Package identifier	<ul style="list-style-type: none"> <li>• FM = 32 QFN (5 mm x 5 mm)</li> <li>• HS = 44 Laminate QFN (5 mm x 5 mm)</li> <li>• LF = 48 LQFP (7 mm x 7 mm)</li> <li>• LH = 64 LQFP (10 mm x 10 mm)</li> </ul>

1. All parts also have FlexNVM, FlexRAM, and RAM.

## 2.4 Example

This is an example part number:

MCF51JF128VLH

## 3 Terminology and guidelines

### 3.1 Definition: Operating requirement

An *operating requirement* is a specified value or range of values for a technical characteristic that you must guarantee during operation to avoid incorrect operation and possibly decreasing the useful life of the chip.

#### 3.1.1 Example

This is an example of an operating requirement:

Symbol	Description	Min.	Max.	Unit
V <sub>DD</sub>	1.0 V core supply voltage	0.9	1.1	V

### 3.2 Definition: Operating behavior

Unless otherwise specified, an *operating behavior* is a specified value or range of values for a technical characteristic that are guaranteed during operation if you meet the operating requirements and any other specified conditions.

### 3.2.1 Example

This is an example of an operating behavior:

Symbol	Description	Min.	Max.	Unit
$I_{WP}$	Digital I/O weak pullup/pulldown current	10	130	$\mu A$

### 3.3 Definition: Attribute

An *attribute* is a specified value or range of values for a technical characteristic that are guaranteed, regardless of whether you meet the operating requirements.

#### 3.3.1 Example

This is an example of an attribute:

Symbol	Description	Min.	Max.	Unit
$C_{IN\_D}$	Input capacitance: digital pins	—	7	pF

### 3.4 Definition: Rating

A *rating* is a minimum or maximum value of a technical characteristic that, if exceeded, may cause permanent chip failure:

- *Operating ratings* apply during operation of the chip.
- *Handling ratings* apply when the chip is not powered.

#### 3.4.1 Example

This is an example of an operating rating:

Symbol	Description	Min.	Max.	Unit
$V_{DD}$	1.0 V core supply voltage	-0.3	1.2	V

### 3.5 Result of exceeding a rating

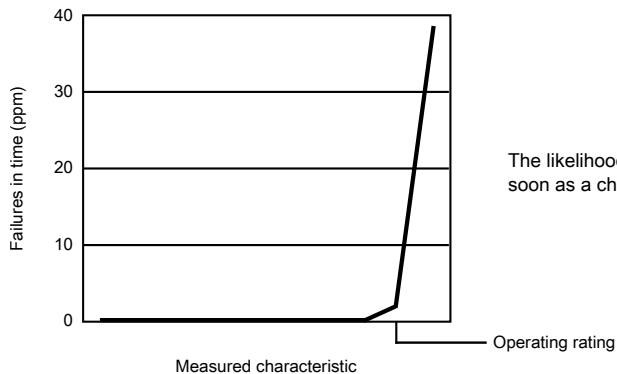

The likelihood of permanent chip failure increases rapidly as soon as a characteristic begins to exceed one of its operating ratings.

### 3.6 Relationship between ratings and operating requirements

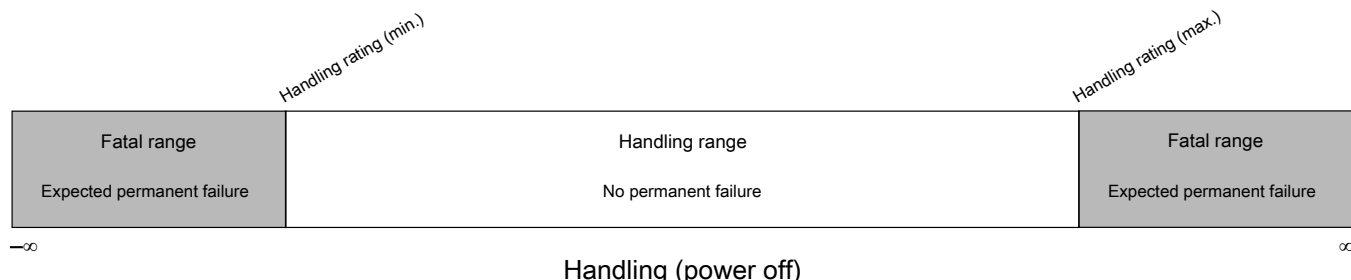
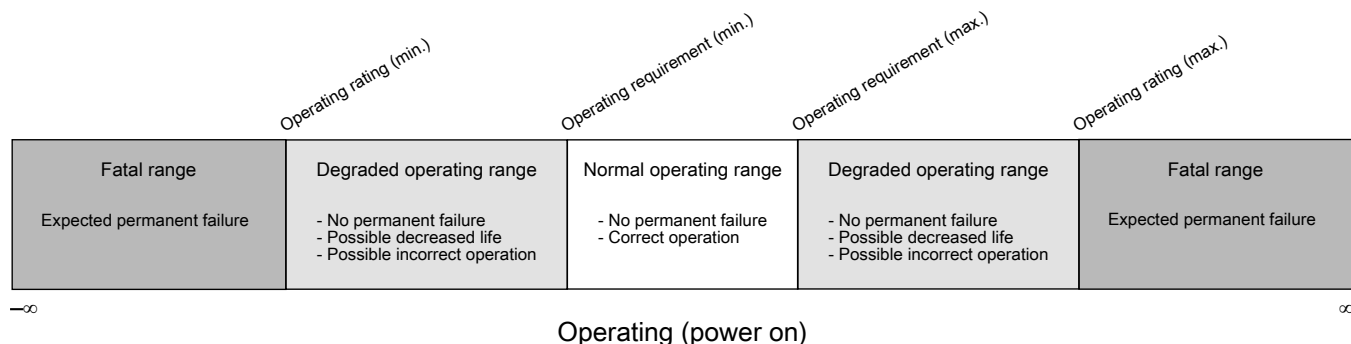

### 3.7 Guidelines for ratings and operating requirements

Follow these guidelines for ratings and operating requirements:

- Never exceed any of the chip’s ratings.
- During normal operation, don’t exceed any of the chip’s operating requirements.
- If you must exceed an operating requirement at times other than during normal operation (for example, during power sequencing), limit the duration as much as possible.

## 3.8 Definition: Typical value

A *typical value* is a specified value for a technical characteristic that:

- Lies within the range of values specified by the operating behavior
- Given the typical manufacturing process, is representative of that characteristic during operation when you meet the typical-value conditions or other specified conditions

Typical values are provided as design guidelines and are neither tested nor guaranteed.

### 3.8.1 Example 1

This is an example of an operating behavior that includes a typical value:

Symbol	Description	Min.	Typ.	Max.	Unit
$I_{WP}$	Digital I/O weak pullup/pulldown current	10	70	130	$\mu\text{A}$

### 3.8.2 Example 2

This is an example of a chart that shows typical values for various voltage and temperature conditions:

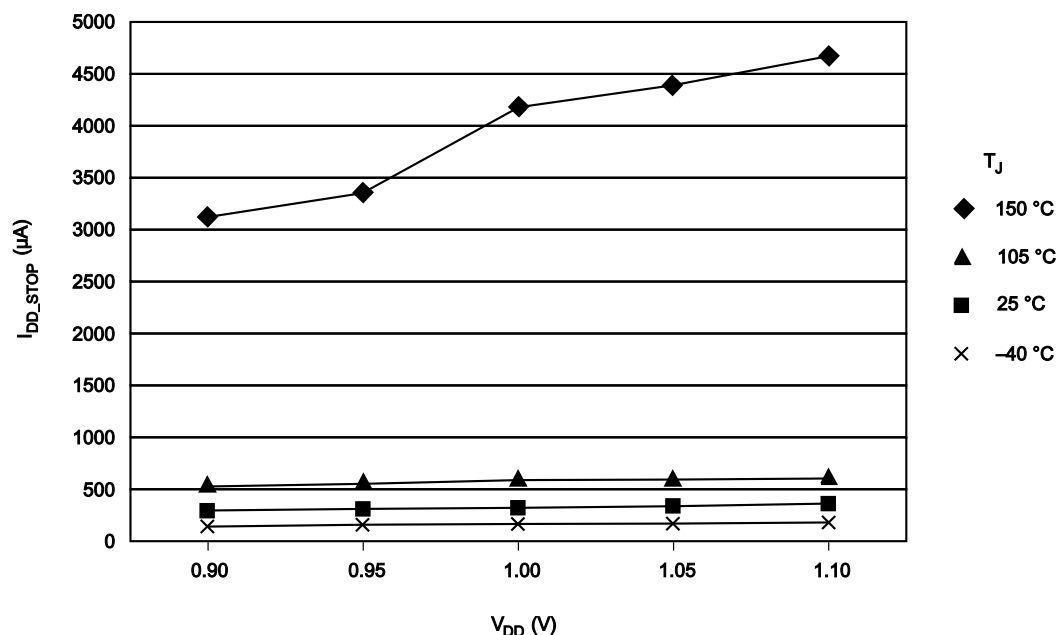

## 4 Ratings

### 4.1 Thermal handling ratings

Symbol	Description	Min.	Max.	Unit	Notes
T <sub>STG</sub>	Storage temperature	-55	150	°C	1
T <sub>SDR</sub>	Solder temperature, lead-free	—	260	°C	2
	Solder temperature, leaded	—	245		

1. Determined according to JEDEC Standard JESD22-A103, *High Temperature Storage Life*.
2. Determined according to IPC/JEDEC Standard J-STD-020, *Moisture/Reflow Sensitivity Classification for Nonhermetic Solid State Surface Mount Devices*.

### 4.2 Moisture handling ratings

Symbol	Description	Min.	Max.	Unit	Notes
MSL	Moisture sensitivity level	—	3	—	1

1. Determined according to IPC/JEDEC Standard J-STD-020, *Moisture/Reflow Sensitivity Classification for Nonhermetic Solid State Surface Mount Devices*.

### 4.3 ESD handling ratings

Symbol	Description	Min.	Max.	Unit	Notes
V <sub>HBM</sub>	Electrostatic discharge voltage, human body model	-2000	+2000	V	1
V <sub>CDM</sub>	Electrostatic discharge voltage, charged-device model	-500	+500	V	2
I <sub>LAT</sub>	Latch-up current at ambient temperature of 105°C	-100	+100	mA	3

1. Determined according to JEDEC Standard JESD22-A114, *Electrostatic Discharge (ESD) Sensitivity Testing Human Body Model (HBM)*.
2. Determined according to JEDEC Standard JESD22-C101, *Field-Induced Charged-Device Model Test Method for Electrostatic-Discharge-Withstand Thresholds of Microelectronic Components*.
3. Determined according to JEDEC Standard JESD78, *IC Latch-Up Test*.

### 4.4 Voltage and current operating ratings

Symbol	Description	Min.	Max.	Unit
$V_{DD}$	Digital supply voltage	-0.3	3.8	V
$I_{DD}$	Digital supply current	—	120	mA
$V_{DIO}$	Digital input voltage (except RESET, EXTAL, and XTAL)	-0.3	$V_{DD} + 0.3$	V
$V_{AIO}$	Analog, RESET, EXTAL, and XTAL input voltage	-0.3	$V_{DD} + 0.3$	V
$I_D$	Instantaneous maximum current single pin limit (applies to all port pins)	-25	25	mA
$V_{DDA}$	Analog supply voltage	$V_{DD} - 0.3$	$V_{DD} + 0.3$	V
$V_{USB\_DP}$	USB_DP input voltage	-0.3	3.63	V
$V_{USB\_DM}$	USB_DM input voltage	-0.3	3.63	V
VREGIN	USB Regulator input	-0.3	6.0	V

## 5 General

### 5.1 Typical Value Conditions

Typical values assume you meet the following conditions (or other conditions as specified):

Symbol	Description	Value	Unit
$T_A$	Ambient temperature	25	°C
$V_{DD}$	3.3 V supply voltage	3.3	V

### 5.2 Nonswitching electrical specifications

#### 5.2.1 Voltage and Current Operating Requirements

Table 1. Voltage and current operating requirements

Symbol	Description	Min.	Max.	Unit	Notes
$V_{DD}$	Supply voltage	1.71	3.6	V	
$V_{DDA}$	Analog supply voltage	1.71	3.6	V	
$V_{DD} - V_{DDA}$	$V_{DD}$ -to- $V_{DDA}$ differential voltage	-0.1	0.1	V	
$V_{SS} - V_{SSA}$	$V_{SS}$ -to- $V_{SSA}$ differential voltage	-0.1	0.1	V	
$V_{IH}$	Input high voltage	$0.7 \times V_{DD}$	—	V	1
		$0.75 \times V_{DD}$	—	V	

Table continues on the next page...

**Table 1. Voltage and current operating requirements (continued)**

Symbol	Description	Min.	Max.	Unit	Notes
	<ul style="list-style-type: none"> <li>• <math>2.7\text{ V} \leq V_{DD} \leq 3.6\text{ V}</math></li> <li>• <math>1.7\text{ V} \leq V_{DD} \leq 2.7\text{ V}</math></li> </ul>				
$V_{IL}$	Input low voltage <ul style="list-style-type: none"> <li>• <math>2.7\text{ V} \leq V_{DD} \leq 3.6\text{ V}</math></li> <li>• <math>1.7\text{ V} \leq V_{DD} \leq 2.7\text{ V}</math></li> </ul>	—	$0.35 \times V_{DD}$	V	2
		—	$0.3 \times V_{DD}$	V	
$I_{IC}$	DC injection current — single pin <ul style="list-style-type: none"> <li>• <math>V_{IN} &gt; V_{DD}</math></li> <li>• <math>V_{IN} &lt; V_{SS}</math></li> </ul>	0	2	mA	3
		0	-0.2	mA	
	DC injection current — total MCU limit, includes sum of all stressed pins <ul style="list-style-type: none"> <li>• <math>V_{IN} &gt; V_{DD}</math></li> <li>• <math>V_{IN} &lt; V_{SS}</math></li> </ul>	0	25	mA	3
		0	-5	mA	
$V_{RAM}$	$V_{DD}$ voltage required to retain RAM	1.2	—	V	

1. The device always interprets an input as a 1 when the input is greater than or equal to  $V_{IH}$  (min.) and less than or equal to  $V_{IH}$  (max.), regardless of whether input hysteresis is turned on.
2. The device always interprets an input as a 0 when the input is less than or equal to  $V_{IL}$  (max.) and greater than or equal to  $V_{IL}$  (min.), regardless of whether input hysteresis is turned on.
3. All functional non-supply pins are internally clamped to VSS and VDD. Input must be current limited to the value specified. To determine the value of the required current-limiting resistor, calculate resistance values for positive and negative clamp voltages, then use the larger of the two values. Power supply must maintain regulation within operating VDD range during instantaneous and operating maximum current conditions. If positive injection current ( $V_{In} > V_{DD}$ ) is greater than  $I_{DD}$ , the injection current may flow out of VDD and could result in external power supply going out of regulation. Ensure external VDD load will shunt current greater than maximum injection current. This will be the greatest risk when the MCU is not consuming power. Examples are: if no system clock is present, or if clock rate is very low (which would reduce overall power consumption).

## 5.2.2 LVD and POR operating requirements

**Table 2. LVD and POR operating requirements**

Symbol	Description	Min.	Typ.	Max.	Unit	Notes
$V_{POR}$	Falling VDD POR detect voltage	0.8	1.1	1.5	V	
$V_{LVDH}$	Falling low-voltage detect threshold — high range (LVDV=01)	2.48	2.56	2.64	V	
$V_{LVW1H}$	Low-voltage warning thresholds — high range <ul style="list-style-type: none"> <li>• Level 1 falling (LVWV=00)</li> <li>• Level 2 falling (LVWV=01)</li> <li>• Level 3 falling (LVWV=10)</li> <li>• Level 4 falling (LVWV=11)</li> </ul>	2.62	2.70	2.78	V	1
$V_{LVW2H}$		2.72	2.80	2.88	V	
$V_{LVW3H}$		2.82	2.90	2.98	V	
$V_{LVW4H}$		2.92	3.00	3.08	V	
$V_{HYSH}$	Low-voltage inhibit reset/recover hysteresis — high range	—	±80	—	mV	

Table continues on the next page...

**Table 2. LVD and POR operating requirements (continued)**

Symbol	Description	Min.	Typ.	Max.	Unit	Notes
V <sub>LVDL</sub>	Falling low-voltage detect threshold — low range (LVDV=00)	1.54	1.60	1.66	V	
V <sub>LWV1L</sub> V <sub>LWV2L</sub> V <sub>LWV3L</sub> V <sub>LWV4L</sub>	Low-voltage warning thresholds — low range <ul style="list-style-type: none"> <li>• Level 1 falling (LVWV=00)</li> <li>• Level 2 falling (LVWV=01)</li> <li>• Level 3 falling (LVWV=10)</li> <li>• Level 4 falling (LVWV=11)</li> </ul>	1.74 1.84 1.94 2.04	1.80 1.90 2.00 2.10	1.86 1.96 2.06 2.16	V V V V	1
V <sub>HYSL</sub>	Low-voltage inhibit reset/recover hysteresis — low range	—	±60	—	mV	
V <sub>BG</sub>	Bandgap voltage reference	0.97	1.00	1.03	V	
t <sub>LPO</sub>	Internal low power oscillator period factory trimmed	900	1000	1100	µs	

1. Rising thresholds are falling threshold + hysteresis voltage

### 5.2.3 Voltage and current operating behaviors

**Table 3. Voltage and current operating behaviors**

Symbol	Description	Min.	Max.	Unit	Notes
V <sub>OH</sub>	Output high voltage — high drive strength <ul style="list-style-type: none"> <li>• 2.7 V ≤ V<sub>DD</sub> ≤ 3.6 V, I<sub>OH</sub> = -9 mA</li> <li>• 1.71 V ≤ V<sub>DD</sub> ≤ 2.7 V, I<sub>OH</sub> = -3 mA</li> </ul>	V <sub>DD</sub> - 0.5 V <sub>DD</sub> - 0.5	— —	V V	
	Output high voltage — low drive strength <ul style="list-style-type: none"> <li>• 2.7 V ≤ V<sub>DD</sub> ≤ 3.6 V, I<sub>OH</sub> = -2 mA</li> <li>• 1.71 V ≤ V<sub>DD</sub> ≤ 2.7 V, I<sub>OH</sub> = -0.6 mA</li> </ul>	V <sub>DD</sub> - 0.5 V <sub>DD</sub> - 0.5	— —	V V	
	Output high current total for all ports	—	100	mA	
	Output low voltage — high drive strength <ul style="list-style-type: none"> <li>• 2.7 V ≤ V<sub>DD</sub> ≤ 3.6 V, I<sub>OL</sub> = 9 mA</li> <li>• 1.71 V ≤ V<sub>DD</sub> ≤ 2.7 V, I<sub>OL</sub> = 3 mA</li> </ul>	— —	0.5 0.5	V V	
V <sub>OL</sub>	Output low voltage — low drive strength <ul style="list-style-type: none"> <li>• 2.7 V ≤ V<sub>DD</sub> ≤ 3.6 V, I<sub>OL</sub> = 2 mA</li> <li>• 1.71 V ≤ V<sub>DD</sub> ≤ 2.7 V, I<sub>OL</sub> = 0.6 mA</li> </ul>	— —	0.5 0.5	V V	
	Output low current total for all ports	—	100	mA	
I <sub>IN</sub>	Input leakage current (per pin) <ul style="list-style-type: none"> <li>• @ full temperature range</li> <li>• @ 25 °C</li> </ul>	— —	1.0 0.1	µA µA	1

Table continues on the next page...

**Table 3. Voltage and current operating behaviors (continued)**

Symbol	Description	Min.	Max.	Unit	Notes
$I_{OZ}$	Hi-Z (off-state) leakage current (per pin)	—	1	$\mu A$	
$I_{OZ}$	Total Hi-Z (off-state) leakage current (all input pins)	—	4	$\mu A$	
$R_{PU}$	Internal pullup resistors	22	50	$k\Omega$	2
$R_{PD}$	Internal pulldown resistors	22	50	$k\Omega$	3

1. Tested by ganged leakage method
2. Measured at  $V_{input} = V_{SS}$
3. Measured at  $V_{input} = V_{DD}$

### 5.2.4 Power mode transition operating behaviors

All specifications except  $t_{POR}$  and VLLSx-RUN recovery times in the following table assume this clock configuration:

- CPU and system clocks = 50 MHz
- Bus clock (and flash and Mini-FlexBus clocks) = 25 MHz

**Table 4. Power mode transition operating behaviors**

Symbol	Description	Min.	Max.	Unit	Notes
$t_{POR}$	After a POR event, amount of time from the point $V_{DD}$ reaches 1.71 V to execution of the first instruction across the operating temperature range of the chip. <ul style="list-style-type: none"> <li>• <math>1.71 V / (V_{DD} \text{ slew rate}) \leq 300 \mu s</math></li> <li>• <math>1.71 V / (V_{DD} \text{ slew rate}) &gt; 300 \mu s</math></li> </ul>	—	300 $1.71 V / (V_{DD} \text{ slew rate})$	$\mu s$	1
	• VLLS1 → RUN	—	132	$\mu s$	1, 2
	• VLLS2 → RUN	—	92	$\mu s$	1, 2
	• VLLS3 → RUN	—	92	$\mu s$	1, 2
	• LLS → RUN	—	7.5	$\mu s$	2
	• VLPS → RUN	—	5.5	$\mu s$	2
	• STOP → RUN	—	5.5	$\mu s$	2

1. Normal boot (FTFL\_FOFT[LPBOOT] is 1)
2. The wakeup time includes the execution time for a small amount of firmware used to produce a GPIO clear event. Wakeup time is measured from the falling edge of the external wakeup event to the falling edge of a GPIO clear performed by software.

## 5.2.5 Power consumption operating behaviors

**Table 5. Power consumption operating behaviors**

Symbol	Description	Min.	Typ.	Max.	Unit	Notes
I <sub>DDA</sub>	Analog supply current	—	—	See note	mA	1
I <sub>DD_RUN</sub>	Run mode current — all peripheral clocks disabled, code executing from RAM <ul style="list-style-type: none"> <li>• @ 1.8 V</li> <li>• @ 3.0 V</li> </ul>	—	13	—	mA	2
		—	13	16	mA	
I <sub>DD_RUN</sub>	Run mode current — all peripheral clocks disabled, code executing from flash memory with page buffering disabled <ul style="list-style-type: none"> <li>• @ 1.8 V</li> <li>• @ 3.0 V</li> </ul>	—	14.3	—	mA	2
		—	14.5	17.9	mA	
I <sub>DD_RUN</sub>	Run mode current — all peripheral clocks enabled, code executing from RAM, exercising flash memory <ul style="list-style-type: none"> <li>• @ 1.8 V</li> <li>• @ 3.0 V</li> </ul>	—	20	23.5	mA	3
		—	20	25	mA	
I <sub>DD_WAIT</sub>	Wait mode current at 3.0 V — all peripheral clocks disabled	—	5.8	6.8	mA	4
I <sub>DD_STOP</sub>	Stop mode current at 3.0 V <ul style="list-style-type: none"> <li>• @ -40 to 25 °C</li> <li>• @ 105 °C</li> </ul>	—	0.34	0.41	mA	
		—	0.90	1.8	mA	
I <sub>DD_VLPR</sub>	Very low-power run mode current at 3.0 V — all peripheral clocks disabled	—	0.63	1.32	mA	5
I <sub>DD_VLPR</sub>	Very low-power run mode current at 3.0 V — all peripheral clocks enabled	—	0.78	1.46	mA	6
I <sub>DD_VLPW</sub>	Very low-power wait mode current at 3.0 V	—	0.15	0.62	mA	7
I <sub>DD_VLPS</sub>	Very low-power stop mode current at 3.0 V <ul style="list-style-type: none"> <li>• @ -40 to 25 °C</li> <li>• @ 105 °C</li> </ul>	—	19	45	μA	8
		—	145	312		
I <sub>DD_LLS</sub>	Low leakage stop mode current at 3.0 V <ul style="list-style-type: none"> <li>• @ -40 to 25 °C</li> <li>• @ 105 °C</li> </ul>	—	3.0	4.8	μA	8,9,10
		—	53.3	157	μA	
I <sub>DD_VLLS3</sub>	Very low-leakage stop mode 3 current at 3.0 V <ul style="list-style-type: none"> <li>• @ -40 to 25 °C</li> <li>• @ 105 °C</li> </ul>	—	1.8	3.3	μA	8,9,10
		—	39.2	115	μA	
I <sub>DD_VLLS2</sub>	Very low-leakage stop mode 2 current at 3.0 V	—	1.6	2.8	μA	8,9
		—	22.2	65	μA	

Table continues on the next page...

**Table 5. Power consumption operating behaviors (continued)**

Symbol	Description	Min.	Typ.	Max.	Unit	Notes
	<ul style="list-style-type: none"> <li>@ -40 to 25 °C</li> <li>@ 105 °C</li> </ul>					
I <sub>DD_VLLS1</sub>	Very low-leakage stop mode 1 current at 3.0 V <ul style="list-style-type: none"> <li>@ -40 to 25 °C</li> <li>@ 105 °C</li> </ul>	—	1.4	2.6	μA	8,9
		—	17.6	50	μA	
I <sub>DD_RTC</sub>	Average current adder for real-time clock function <ul style="list-style-type: none"> <li>@ -40 to 25 °C</li> </ul>	—	0.7	—	μA	11

- The analog supply current is the sum of the active current for each of the analog modules on the device. See each module's specification for its supply current.
- 50 MHz core and system clocks, and 25 MHz bus clock. MCG configured for FEI mode. All peripheral clocks disabled.
- 50 MHz core and system clocks, and 25 MHz bus clock. MCG configured for FEI mode. All peripheral clocks enabled, but peripherals are not in active operation.
- 50 MHz core and system clocks, and 25 MHz bus clock. MCG configured for FEI mode.
- 2 MHz core and system clocks, and 1 MHz bus clock. MCG configured for BLPE mode. All peripheral clocks disabled. Code executing from flash memory.
- 2 MHz core and system clocks, and 1 MHz bus clock. MCG configured for BLPE mode. All peripheral clocks enabled, but peripherals are not in active operation. Code executing from flash memory.
- 2 MHz core and system clocks, and 1 MHz bus clock. MCG configured for BLPE mode. All peripheral clocks disabled.
- OSC clocks disabled.
- All pads disabled.
- Data reflects devices with 32 KB of RAM. For devices with 16 KB of RAM, power consumption is reduced by 500 nA. For devices with 8 KB of RAM, power consumption is reduced by 750 nA.
- RTC function current includes LPTMR with OSC enabled with 32.768 kHz crystal at 3.0 V

### 5.2.5.1 Diagram: Typical I<sub>DD\_RUN</sub> operating behavior

The following data was measured under these conditions:

- MCG in FBE mode, except for 50 MHz core (FEI mode)
- For the ALLOFF curve, all peripheral clocks are disabled except FTFL
- For the ALLON curve, all peripheral clocks are enabled, but peripherals are not in active operation
- USB Voltage Regulator disabled
- No GPIOs toggled
- Code execution from flash memory with cache enabled

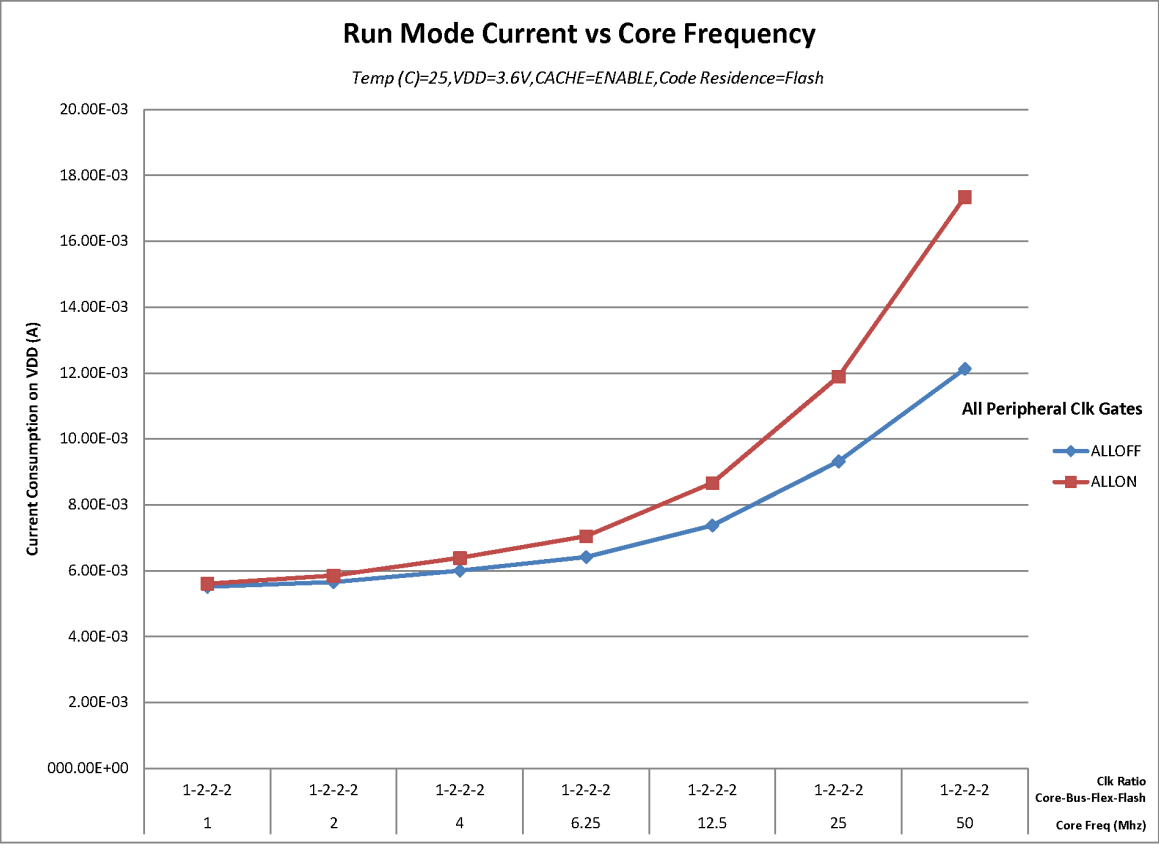

Figure 1. Run mode supply current vs. core frequency

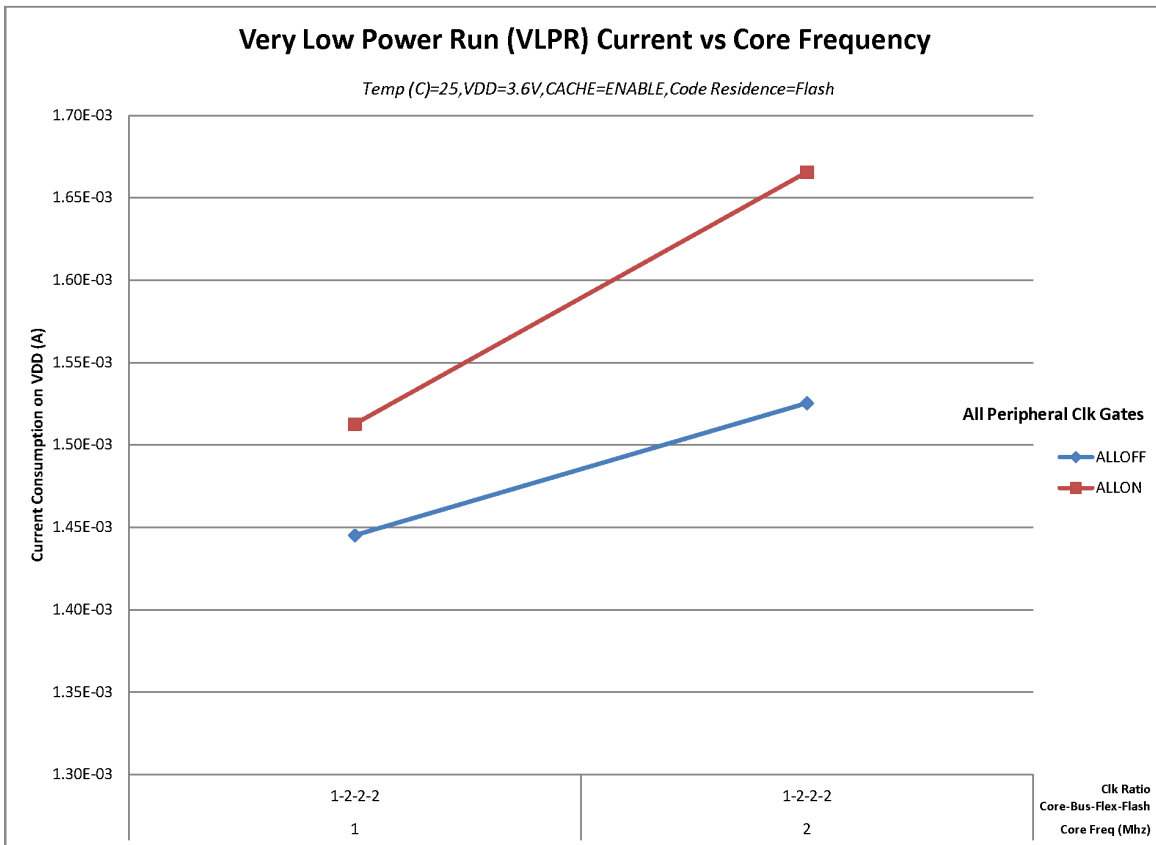

Figure 2. VLPR mode supply current vs. core frequency

### 5.2.6 EMC radiated emissions operating behaviors

Table 6. EMC radiated emissions operating behaviors

Symbol	Description	Frequency band (MHz)	Typ.	Unit	Notes
V <sub>RE1</sub>	Radiated emissions voltage, band 1	0.15–50	20	dBμV	1, 2
V <sub>RE2</sub>	Radiated emissions voltage, band 2	50–150	19		
V <sub>RE3</sub>	Radiated emissions voltage, band 3	150–500	17		
V <sub>RE4</sub>	Radiated emissions voltage, band 4	500–1000	16		
V <sub>RE_IEC</sub>	IEC level	0.15–1000	L	—	2, 3

1. Determined according to IEC Standard 61967-1, *Integrated Circuits - Measurement of Electromagnetic Emissions, 150 kHz to 1 GHz Part 1: General Conditions and Definitions*, and IEC Standard 61967-2, *Integrated Circuits - Measurement of Electromagnetic Emissions, 150 kHz to 1 GHz Part 2: Measurement of Radiated Emissions—TEM Cell and Wideband TEM Cell Method*.
2.  $V_{DD} = 3\text{ V}$ ,  $T_A = 25\text{ }^\circ\text{C}$ ,  $f_{OSC} = 32\text{ kHz}$  (crystal),  $f_{BUS} = 24\text{ MHz}$
3. Specified according to Annex D of IEC Standard 61967-2, *Measurement of Radiated Emissions—TEM Cell and Wideband TEM Cell Method*

### 5.2.7 Designing with radiated emissions in mind

To find application notes that provide guidance on designing your system to minimize interference from radiated emissions:

1. Go to [www.freescale.com](http://www.freescale.com).
2. Perform a keyword search for “EMC design.”

### 5.2.8 Capacitance attributes

Table 7. Capacitance attributes

Symbol	Description	Min.	Max.	Unit
$C_{IN\_A}$	Input capacitance: analog pins	—	7	pF
$C_{IN\_D}$	Input capacitance: digital pins	—	7	pF

## 5.3 Switching electrical specifications

Table 8. Device clock specifications

Symbol	Description	Min.	Max.	Unit	Notes
Normal run mode					
$f_{SYS}$	System and core clock	—	50	MHz	
$f_{SYS\_USB}$	System and core clock when USB in operation	20	—	MHz	
$f_{BUS}$	Bus clock	—	25	MHz	
FB_CLK	Mini-FlexBus clock	—	25	MHz	1
$f_{LPTMR}$	LPTMR clock	—	25	MHz	
VLPR mode					
$f_{SYS}$	System and core clock	—	2	MHz	
$f_{BUS}$	Bus clock	—	1	MHz	
FB_CLK	Mini-FlexBus clock	—	1	MHz	1
$f_{LPTMR}$	LPTMR clock <sup>2</sup>	—	25	MHz	

## nonswitching electrical specifications

1. When the Mini-FlexBus is enabled, its clock frequency is always the same as the bus clock frequency.
2. A maximum frequency of 25 MHz for the LPTMR in VLPR mode is possible when the LPTMR is configured for pulse counting mode and is driven externally via the LPTMR\_ALT1, LPTMR\_ALT2, or LPTMR\_ALT3 pin.

### 5.3.1 General Switching Specifications

These general purpose specifications apply to all signals configured for EGPIO, MTIM, CMT, PDB, IRQ, and I<sup>2</sup>C signals. The conditions are 50 pf load, V<sub>DD</sub> = 1.71 V to 3.6 V, and full temperature range. The GPIO are set for high drive, no slew rate control, and no input filter, digital or analog, unless otherwise specified.

**Table 9. EGPIO General Control Timing**

Symbol	Description	Min.	Max.	Unit
G1	Bus clock from CLK_OUT pin high to GPIO output valid	—	32	ns
G2	Bus clock from CLK_OUT pin high to GPIO output invalid (output hold)	1	—	ns
G3	GPIO input valid to bus clock high	28	—	ns
G4	Bus clock from CLK_OUT pin high to GPIO input invalid	—	4	ns
	GPIO pin interrupt pulse width (digital glitch filter disabled) Synchronous path <sup>1</sup>	1.5	—	Bus clock cycles
	GPIO pin interrupt pulse width (digital glitch filter disabled, analog filter enabled) Asynchronous path <sup>2</sup>	100	—	ns
	GPIO pin interrupt pulse width (digital glitch filter disabled, analog filter disabled) Asynchronous path <sup>2</sup>	50	—	ns
	External reset pulse width (digital glitch filter disabled)	100	—	ns
	Mode select (MS) hold time after reset deassertion	2	—	Bus clock cycles

1. The greater synchronous and asynchronous timing must be met.
2. This is the shortest pulse that is guaranteed to be recognized.

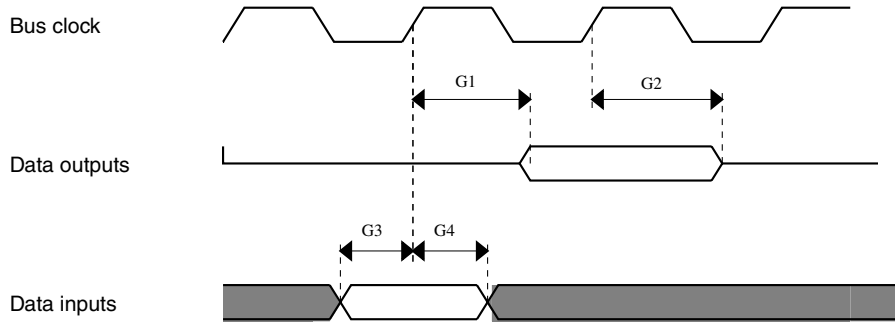
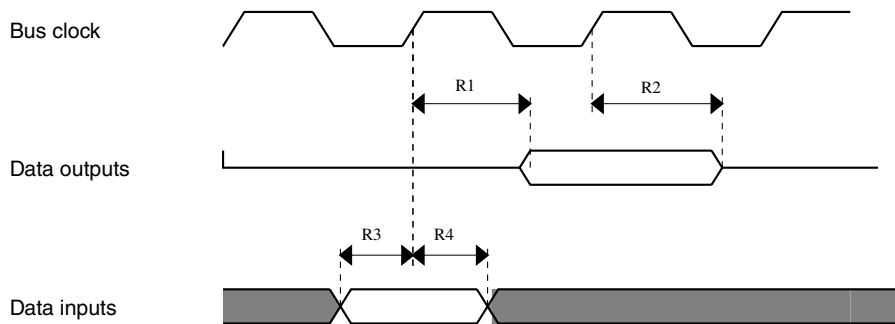

**Figure 3. EGPIO timing diagram**

The following general purpose specifications apply to all signals configured for RGPIO, FTM, and UART. The conditions are 25 pf load,  $V_{DD} = 3.6\text{ V to }1.71\text{ V}$ , and full temperature range. The GPIO are set for high drive, no slew rate control, and no input filter, digital or analog, unless otherwise specified.

**Table 10. RGPIO General Control Timing**

Symbol	Description	Min.	Max.	Unit
R1	CPUCLK from CLK_OUT pin high to GPIO output valid	—	16	ns
R2	CPUCLK from CLK_OUT pin high to GPIO output invalid (output hold)	1	—	ns
R3	GPIO input valid to bus clock high	17	—	ns
R4	CPUCLK from CLK_OUT pin high to GPIO input invalid	—	2	ns



**Figure 4. RGPIO timing diagram**

## 5.4 Thermal specifications

### 5.4.1 Thermal operating requirements

Table 11. Thermal operating requirements

Symbol	Description	Min.	Max.	Unit
$T_J$	Die junction temperature	-40	115	°C
$T_A$	Ambient temperature	-40	105	°C

### 5.4.2 Thermal attributes

Board type	Symbol	Description	64 LQFP	48 LQFP	44 Laminate QFN	32 QFN	Unit	Notes
Single-layer (1s)	$R_{\theta JA}$	Thermal resistance, junction to ambient (natural convection)	73	79	108	98	°C/W	1
Four-layer (2s2p)	$R_{\theta JA}$	Thermal resistance, junction to ambient (natural convection)	54	55	69	33	°C/W	1
Single-layer (1s)	$R_{\theta JMA}$	Thermal resistance, junction to ambient (200 ft./min. air speed)	61	66	91	81	°C/W	1
Four-layer (2s2p)	$R_{\theta JMA}$	Thermal resistance, junction to ambient (200 ft./min. air speed)	48	48	63	28	°C/W	1
—	$R_{\theta JB}$	Thermal resistance, junction to board	37	34	44	13	°C/W	2
—	$R_{\theta JC}$	Thermal resistance, junction to case	20	20	31	2.2	°C/W	3
—	$\Psi_{JT}$	Thermal characterization parameter, junction to package top outside center (natural convection)	5.0	4.0	6.0	6.0	°C/W	4

1. Determined according to JEDEC Standard JESD51-2, *Integrated Circuits Thermal Test Method Environmental Conditions – Natural Convection (Still Air)*, or EIA/JEDEC Standard JESD51-6, *Integrated Circuit Thermal Test Method Environmental Conditions – Forced Convection (Moving Air)*.
2. Determined according to JEDEC Standard JESD51-8, *Integrated Circuit Thermal Test Method Environmental Conditions – Junction-to-Board*.
3. Determined according to Method 1012.1 of MIL-STD 883, *Test Method Standard, Microcircuits*, with the cold plate temperature used for the case temperature. The value includes the thermal resistance of the interface material between the top of the package and the cold plate.
4. Determined according to JEDEC Standard JESD51-2, *Integrated Circuits Thermal Test Method Environmental Conditions – Natural Convection (Still Air)*.

## 6 Peripheral operating requirements and behaviors

### 6.1 Core modules

#### 6.1.1 Debug specifications

**Table 12. Background debug mode (BDM) timing**

Number	Symbol	Description	Min.	Max.	Unit
1	$t_{MSSU}$	BKGD/MS setup time after issuing background debug force reset to enter user mode or BDM	500	—	ns
2	$t_{MSH}$	BKGD/MS hold time after issuing background debug force reset to enter user mode or BDM <sup>1</sup>	100	—	$\mu$ s

1. To enter BDM mode following a POR, BKGD/MS should be held low during the power-up and for a hold time of  $t_{MSH}$  after  $V_{DD}$  rises above  $V_{LVD}$ .

### 6.2 System modules

There are no specifications necessary for the device's system modules.

### 6.3 Clock modules

#### 6.3.1 MCG specifications

**Table 13. MCG specifications**

Symbol	Description	Min.	Typ.	Max.	Unit	Notes
$f_{ints\_ft}$	Internal reference frequency (slow clock) — factory trimmed at nominal VDD and 25 °C	—	32.768	—	kHz	
$f_{ints\_t}$	Internal reference frequency (slow clock) — user trimmed	31.25	—	38.214	kHz	
$\Delta f_{dco\_res\_t}$	Resolution of trimmed average DCO output frequency at fixed voltage and temperature — using SCTRIM and SCFTRIM	—	$\pm 0.3$	$\pm 0.6$	% $f_{dco}$	1
$\Delta f_{dco\_res\_t}$	Resolution of trimmed average DCO output frequency at fixed voltage and temperature — using SCTRIM only	—	$\pm 0.2$	$\pm 0.5$	% $f_{dco}$	1
$\Delta f_{dco\_t}$	Total deviation of trimmed average DCO output frequency over voltage and temperature	—	$\pm 10$	—	% $f_{dco}$	1

Table continues on the next page...

**Table 13. MCG specifications (continued)**

Symbol	Description	Min.	Typ.	Max.	Unit	Notes	
$\Delta f_{dco\_t}$	Total deviation of trimmed average DCO output frequency over fixed voltage and temperature range of 0–70°C	—	± 4.5	—	% $f_{dco}$	1	
$f_{intf\_ft}$	Internal reference frequency (fast clock) — factory trimmed at nominal VDD and 25°C	—	3.3	4	MHz		
$f_{intf\_t}$	Internal reference frequency (fast clock) — user trimmed at nominal VDD and 25 °C	3	—	5	MHz		
$f_{loc\_low}$	Loss of external clock minimum frequency — RANGE = 00	$(3/5) \times f_{ints\_t}$	—	—	kHz		
$f_{loc\_high}$	Loss of external clock minimum frequency — RANGE = 01, 10, or 11	$(16/5) \times f_{ints\_t}$	—	—	kHz		
FLL							
$f_{fill\_ref}$	FLL reference frequency range	31.25	—	39.0625	kHz		
$f_{dco}$	DCO output frequency range	Low range (DRS=00) $640 \times f_{fill\_ref}$	20	20.97	25	MHz	2, 3
		Mid range (DRS=01) $1280 \times f_{fill\_ref}$	40	41.94	50	MHz	
		Mid-high range (DRS=10) $1920 \times f_{fill\_ref}$	60	62.91	75	MHz	
		High range (DRS=11) $2560 \times f_{fill\_ref}$	80	83.89	100	MHz	
$f_{dco\_t\_DMX32}$	DCO output frequency	Low range (DRS=00) $732 \times f_{fill\_ref}$	—	23.99	—	MHz	4, 5
		Mid range (DRS=01) $1464 \times f_{fill\_ref}$	—	47.97	—	MHz	
		Mid-high range (DRS=10) $2197 \times f_{fill\_ref}$	—	71.99	—	MHz	
		High range (DRS=11) $2929 \times f_{fill\_ref}$	—	95.98	—	MHz	
$J_{cyc\_fill}$	FLL period jitter	• $f_{DCO} = 48$ MHz	—	180	—	ps	
		• $f_{DCO} = 98$ MHz	—	150	—		
$t_{fill\_acquire}$	FLL target frequency acquisition time	—	—	1	ms	6	
PLL							
$f_{vco}$	VCO operating frequency	48.0	—	100	MHz		
$I_{pll}$	PLL operating current	• PLL @ 96 MHz ( $f_{osc\_hi\_1} = 8$ MHz, $f_{pll\_ref} = 2$ MHz, VDIV multiplier = 48)	—	1060	—	μA	7
		• PLL @ 48 MHz ( $f_{osc\_hi\_1} = 8$ MHz, $f_{pll\_ref} = 2$ MHz, VDIV multiplier = 24)	—	600	—	μA	
$f_{pll\_ref}$	PLL reference frequency range	2.0	—	4.0	MHz		

Table continues on the next page...

**Table 13. MCG specifications (continued)**

Symbol	Description	Min.	Typ.	Max.	Unit	Notes
$J_{cyc\_pll}$	PLL period jitter (RMS) <ul style="list-style-type: none"> <li><math>f_{vco} = 48</math> MHz</li> <li><math>f_{vco} = 100</math> MHz</li> </ul>	—	120	—	ps	8
		—	50	—	ps	
$J_{acc\_pll}$	PLL accumulated jitter over 1 $\mu$ s (RMS) <ul style="list-style-type: none"> <li><math>f_{vco} = 48</math> MHz</li> <li><math>f_{vco} = 100</math> MHz</li> </ul>	—	1350	—	ps	8
		—	600	—	ps	
$D_{lock}$	Lock entry frequency tolerance	$\pm 1.49$	—	$\pm 2.98$	%	
$D_{unl}$	Lock exit frequency tolerance	$\pm 4.47$	—	$\pm 5.97$	%	
$t_{pll\_lock}$	Lock detector detection time	—	—	$150 \times 10^{-6} + 1075(1/f_{pll\_ref})$	s	9

1. This parameter is measured with the internal reference (slow clock) being used as a reference to the FLL (FEI clock mode).
2. These typical values listed are with the slow internal reference clock (FEI) using factory trim and DMX32=0.
3. The resulting system clock frequencies should not exceed their maximum specified values. The DCO frequency deviation ( $\Delta f_{dco\_t}$ ) over voltage and temperature should be considered.
4. These typical values listed are with the slow internal reference clock (FEI) using factory trim and DMX32=1.
5. The resulting clock frequency must not exceed the maximum specified clock frequency of the device.
6. This specification applies to any time the FLL reference source or reference divider is changed, trim value is changed, DMX32 bit is changed, DRS bits are changed, or changing from FLL disabled (BLPE, BLPI) to FLL enabled (FEI, FEE, FBE, FBI). If a crystal/resonator is being used as the reference, this specification assumes it is already running.
7. Excludes any oscillator currents that are also consuming power while PLL is in operation.
8. This specification was obtained using a Freescale developed PCB. PLL jitter is dependent on the noise characteristics of each PCB and results will vary.
9. This specification applies to any time the PLL VCO divider or reference divider is changed, or changing from PLL disabled (BLPE, BLPI) to PLL enabled (PBE, PEE). If a crystal/resonator is being used as the reference, this specification assumes it is already running.

## 6.3.2 Oscillator electrical specifications

### 6.3.2.1 Oscillator DC electrical specifications

**Table 14. Oscillator DC electrical specifications**

Symbol	Description	Min.	Typ.	Max.	Unit	Notes
$V_{DD}$	Supply voltage	1.71	—	3.6	V	
$I_{DDOSC}$	Supply current — low-power mode (HGO=0) <ul style="list-style-type: none"> <li>32 kHz</li> <li>1 MHz</li> <li>4 MHz</li> <li>8 MHz (RANGE=01)</li> </ul>	—	500	—	nA	1
		—	200	—	$\mu$ A	
		—	200	—	$\mu$ A	
		—	300	—	$\mu$ A	
		—	950	—	$\mu$ A	

Table continues on the next page...

**Table 14. Oscillator DC electrical specifications (continued)**

Symbol	Description	Min.	Typ.	Max.	Unit	Notes
	<ul style="list-style-type: none"> <li>• 16 MHz</li> <li>• 24 MHz</li> <li>• 32 MHz</li> </ul>	—	1.2	—	mA	
		—	1.5	—	mA	
I <sub>DDOSC</sub>	Supply current — high-gain mode (HGO=1) <ul style="list-style-type: none"> <li>• 32 kHz</li> <li>• 1 MHz</li> <li>• 4 MHz</li> <li>• 8 MHz (RANGE=01)</li> <li>• 16 MHz</li> <li>• 24 MHz</li> <li>• 32 MHz</li> </ul>	—	25	—	μA	1
		—	300	—	μA	
		—	400	—	μA	
		—	500	—	μA	
		—	2.5	—	mA	
		—	3	—	mA	
		—	4	—	mA	
C <sub>x</sub>	EXTAL load capacitance	—	—	—		2, 3
C <sub>y</sub>	XTAL load capacitance	—	—	—		2, 3
R <sub>F</sub>	Feedback resistor — low-frequency, low-power mode (HGO=0)	—	—	—	MΩ	2, 4
	Feedback resistor — low-frequency, high-gain mode (HGO=1)	—	10	—	MΩ	
	Feedback resistor — high-frequency, low-power mode (HGO=0)	—	—	—	MΩ	
	Feedback resistor — high-frequency, high-gain mode (HGO=1)	—	1	—	MΩ	
R <sub>S</sub>	Series resistor — low-frequency, low-power mode (HGO=0)	—	—	—	kΩ	
	Series resistor — low-frequency, high-gain mode (HGO=1)	—	200	—	kΩ	
	Series resistor — high-frequency, low-power mode (HGO=0)	—	—	—	kΩ	
	Series resistor — high-frequency, high-gain mode (HGO=1)					
	<ul style="list-style-type: none"> <li>• 1 MHz resonator</li> </ul>	—	6.6	—	kΩ	
	<ul style="list-style-type: none"> <li>• 2 MHz resonator</li> </ul>	—	3.3	—	kΩ	
	<ul style="list-style-type: none"> <li>• 4 MHz resonator</li> </ul>	—	0	—	kΩ	
	<ul style="list-style-type: none"> <li>• 8 MHz resonator</li> </ul>	—	0	—	kΩ	
<ul style="list-style-type: none"> <li>• 16 MHz resonator</li> </ul>	—	0	—	kΩ		
<ul style="list-style-type: none"> <li>• 20 MHz resonator</li> </ul>	—	0	—	kΩ		
<ul style="list-style-type: none"> <li>• 32 MHz resonator</li> </ul>	—	0	—	kΩ		
V <sub>pp</sub> <sup>5</sup>	Peak-to-peak amplitude of oscillation (oscillator mode) — low-frequency, low-power mode (HGO=0)	—	0.6	—	V	

Table continues on the next page...

**Table 14. Oscillator DC electrical specifications (continued)**

Symbol	Description	Min.	Typ.	Max.	Unit	Notes
	Peak-to-peak amplitude of oscillation (oscillator mode) — low-frequency, high-gain mode (HGO=1)	—	$V_{DD}$	—	V	
	Peak-to-peak amplitude of oscillation (oscillator mode) — high-frequency, low-power mode (HGO=0)	—	0.6	—	V	
	Peak-to-peak amplitude of oscillation (oscillator mode) — high-frequency, high-gain mode (HGO=1)	—	$V_{DD}$	—	V	

1.  $V_{DD}=3.3$  V, Temperature =25 °C
2. See crystal or resonator manufacturer's recommendation
3.  $C_x$  and  $C_y$  can be provided by using either integrated capacitors or external components.
4. When low-power mode is selected,  $R_F$  is integrated and must not be attached externally.
5. The EXTAL and XTAL pins should only be connected to required oscillator components and must not be connected to any other device.

### 6.3.2.2 Oscillator frequency specifications

**Table 15. Oscillator frequency specifications**

Symbol	Description	Min.	Typ.	Max.	Unit	Notes
$f_{osc\_lo}$	Oscillator crystal or resonator frequency — low-frequency mode (MCG_C2[RANGE]=00)	32	—	40	kHz	
$f_{osc\_hi\_1}$	Oscillator crystal or resonator frequency — high-frequency mode (low range) (MCG_C2[RANGE]=01)	1	—	8	MHz	
$f_{osc\_hi\_2}$	Oscillator crystal or resonator frequency — high frequency mode (high range) (MCG_C2[RANGE]=1x)	8	—	32	MHz	
$f_{ec\_extal}$	Input clock frequency (external clock mode)	—	—	50	MHz	1, 2
$t_{dc\_extal}$	Input clock duty cycle (external clock mode)	40	50	60	%	
$t_{cst}$	Crystal startup time — 32 kHz low-frequency, low-power mode (HGO=0)	—	750	—	ms	3, 4
	Crystal startup time — 32 kHz low-frequency, high-gain mode (HGO=1)	—	250	—	ms	
	Crystal startup time — 8 MHz high-frequency (MCG_C2[RANGE]=01), low-power mode (HGO=0)	—	0.6	—	ms	
	Crystal startup time — 8 MHz high-frequency (MCG_C2[RANGE]=01), high-gain mode (HGO=1)	—	1	—	ms	

1. Other frequency limits may apply when external clock is being used as a reference for the FLL or PLL.
2. When transitioning from FEI or FBI to FBE mode, restrict the frequency of the input clock so that, when it is divided by FRDIV, it remains within the limits of the DCO input clock frequency.
3. Proper PC board layout procedures must be followed to achieve specifications.
4. Crystal startup time is defined as the time between the oscillator being enabled and the OSCINIT bit in the MCG\_S register being set.

## 6.4 Memories and memory interfaces

### 6.4.1 Flash electrical specifications

This section describes the electrical characteristics of the flash memory module.

#### 6.4.1.1 Flash timing specifications — program and erase

The following specifications represent the amount of time the internal charge pumps are active and do not include command overhead.

**Table 16. NVM program/erase timing specifications**

Symbol	Description	Min.	Typ.	Max.	Unit	Notes
$t_{hvp\text{gm}4}$	Longword Program high-voltage time	—	7.5	18	$\mu\text{s}$	—
$t_{h\text{ver}sscr}$	Sector Erase high-voltage time	—	13	113	ms	1
$t_{h\text{vers}blk32k}$	Erase Block high-voltage time for 32 KB	—	52	452	ms	1
$t_{h\text{vers}blk128k}$	Erase Block high-voltage time for 128 KB	—	208	1808	ms	1

1. Maximum time based on expectations at cycling end-of-life.

#### 6.4.1.2 Flash timing specifications — commands

**Table 17. Flash command timing specifications**

Symbol	Description	Min.	Typ.	Max.	Unit	Notes
$t_{rd1blk32k}$	Read 1s Block execution time	—	—	0.5	ms	1
$t_{rd1blk128k}$	<ul style="list-style-type: none"> <li>32 KB data flash</li> <li>128 KB program flash</li> </ul>	—	—	1.7	ms	
$t_{rd1sec1k}$	Read 1s Section execution time (flash sector)	—	—	60	$\mu\text{s}$	1
$t_{pgmchk}$	Program Check execution time	—	—	45	$\mu\text{s}$	1
$t_{rd\text{r}src}$	Read Resource execution time	—	—	30	$\mu\text{s}$	1
$t_{pgm4}$	Program Longword execution time	—	65	145	$\mu\text{s}$	—
$t_{ersblk32k}$	Erase Flash Block execution time	—	55	465	ms	2
$t_{ersblk128k}$	<ul style="list-style-type: none"> <li>32 KB data flash</li> <li>128 KB program flash</li> </ul>	—	220	1850	ms	
$t_{er\text{ss}cr}$	Erase Flash Sector execution time	—	14	114	ms	2
$t_{pgmsec512}$	Program Section execution time	—	4.7	—	ms	—
$t_{pgmsec1k}$	<ul style="list-style-type: none"> <li>512 bytes flash</li> <li>1 KB flash</li> </ul>	—	9.3	—	ms	

Table continues on the next page...

**Table 17. Flash command timing specifications (continued)**

Symbol	Description	Min.	Typ.	Max.	Unit	Notes
$t_{rd1all}$	Read 1s All Blocks execution time	—	—	1.8	ms	1
$t_{rdonce}$	Read Once execution time	—	—	25	$\mu$ s	1
$t_{pgmonce}$	Program Once execution time	—	65	—	$\mu$ s	—
$t_{ersall}$	Erase All Blocks execution time	—	275	2350	ms	2
$t_{vfykey}$	Verify Backdoor Access Key execution time	—	—	30	$\mu$ s	1
$t_{pgmpart32k}$	Program Partition for EEPROM execution time • 32 KB FlexNVM	—	70	—	ms	—
$t_{setramff}$	Set FlexRAM Function execution time: • Control Code 0xFF	—	50	—	$\mu$ s	—
$t_{setram8k}$	• 8 KB EEPROM backup	—	0.3	0.5	ms	—
$t_{setram32k}$	• 32 KB EEPROM backup	—	0.7	1.0	ms	—
Byte-write to FlexRAM for EEPROM operation						
$t_{eewr8bers}$	Byte-write to erased FlexRAM location execution time	—	175	260	$\mu$ s	3
$t_{eewr8b8k}$	Byte-write to FlexRAM execution time: • 8 KB EEPROM backup	—	340	1700	$\mu$ s	—
$t_{eewr8b16k}$	• 16 KB EEPROM backup	—	385	1800	$\mu$ s	—
$t_{eewr8b32k}$	• 32 KB EEPROM backup	—	475	2000	$\mu$ s	—
Word-write to FlexRAM for EEPROM operation						
$t_{eewr16bers}$	Word-write to erased FlexRAM location execution time	—	175	260	$\mu$ s	—
$t_{eewr16b8k}$	Word-write to FlexRAM execution time: • 8 KB EEPROM backup	—	340	1700	$\mu$ s	—
$t_{eewr16b16k}$	• 16 KB EEPROM backup	—	385	1800	$\mu$ s	—
$t_{eewr16b32k}$	• 32 KB EEPROM backup	—	475	2000	$\mu$ s	—
Longword-write to FlexRAM for EEPROM operation						
$t_{eewr32bers}$	Longword-write to erased FlexRAM location execution time	—	360	540	$\mu$ s	—
$t_{eewr32b8k}$	Longword-write to FlexRAM execution time: • 8 KB EEPROM backup	—	545	1950	$\mu$ s	—
$t_{eewr32b16k}$	• 16 KB EEPROM backup	—	630	2050	$\mu$ s	—
$t_{eewr32b32k}$	• 32 KB EEPROM backup	—	810	2250	$\mu$ s	—

1. Assumes 25 MHz flash clock frequency.
2. Maximum times for erase parameters based on expectations at cycling end-of-life.
3. For byte-writes to an erased FlexRAM location, the aligned word containing the byte must be erased.

### 6.4.1.3 Flash high voltage current behaviors

Table 18. Flash high voltage current behaviors

Symbol	Description	Min.	Typ.	Max.	Unit
I <sub>DD_PGM</sub>	Average current adder during high voltage flash programming operation	—	2.5	6.0	mA
I <sub>DD_ERS</sub>	Average current adder during high voltage flash erase operation	—	1.5	4.0	mA

### 6.4.1.4 Reliability specifications

Table 19. NVM reliability specifications

Symbol	Description	Min.	Typ. <sup>1</sup>	Max.	Unit	Notes
Program Flash						
t <sub>nvmretp10k</sub>	Data retention after up to 10 K cycles	5	50	—	years	2
t <sub>nvmretp1k</sub>	Data retention after up to 1 K cycles	20	100	—	years	2
t <sub>nvmretp100</sub>	Data retention after up to 100 cycles	15	100	—	years	2
n <sub>nvmcycp</sub>	Cycling endurance	10 K	50 K	—	cycles	3
Data Flash						
t <sub>nvmretd10k</sub>	Data retention after up to 10 K cycles	5	50	—	years	2
t <sub>nvmretd1k</sub>	Data retention after up to 1 K cycles	20	100	—	years	2
t <sub>nvmretd100</sub>	Data retention after up to 100 cycles	15	100	—	years	2
n <sub>nvmcycd</sub>	Cycling endurance	10 K	50 K	—	cycles	3
FlexRAM as EEPROM						
t <sub>nvmretee100</sub>	Data retention up to 100% of write endurance	5	50	—	years	2
t <sub>nvmretee10</sub>	Data retention up to 10% of write endurance	20	100	—	years	2
t <sub>nvmretee1</sub>	Data retention up to 1% of write endurance	15	100	—	years	2
n <sub>nvmwree16</sub>	Write endurance <ul style="list-style-type: none"> <li>• EEPROM backup to FlexRAM ratio = 16</li> <li>• EEPROM backup to FlexRAM ratio = 128</li> <li>• EEPROM backup to FlexRAM ratio = 512</li> <li>• EEPROM backup to FlexRAM ratio = 4096</li> <li>• EEPROM backup to FlexRAM ratio = 8192</li> </ul>	35 K	175 K	—	writes	4
n <sub>nvmwree128</sub>		315 K	1.6 M	—	writes	
n <sub>nvmwree512</sub>		1.27 M	6.4 M	—	writes	
n <sub>nvmwree4k</sub>		10 M	50 M	—	writes	
n <sub>nvmwree8k</sub>		20 M	100 M	—	writes	

1. Typical data retention values are based on measured response accelerated at high temperature and derated to a constant 25 °C use profile. Engineering Bulletin EB618 does not apply to this technology. Typical endurance defined in Engineering Bulletin EB619.
2. Typical data retention values are based on measured response accelerated at high temperature and derated to a constant 25°C use profile. Engineering Bulletin EB618 does not apply to this technology.
3. Cycling endurance represents number of program/erase cycles at  $-40\text{ °C} \leq T_j \leq 125\text{ °C}$ .
4. Write endurance represents the number of writes to each FlexRAM location at  $-40\text{ °C} \leq T_j \leq 125\text{ °C}$  influenced by the cycling endurance of the FlexNVM (same value as data flash) and the allocated EEPROM backup. Minimum and typical values assume all byte-writes to FlexRAM.

## 6.4.2 EzPort Switching Specifications

All timing is shown with respect to a maximum pin load of 50 pF and input signal transitions of 3 ns.

**Table 20. EzPort switching specifications**

Num	Description	Min.	Max.	Unit
	Operating voltage	2.7	3.6	V
EP1	EZP_CK frequency of operation (all commands except READ)	—	$f_{SYS}/2$	MHz
EP1a	EZP_CK frequency of operation (READ command)	—	$f_{SYS}/8$	MHz
EP2	$\overline{\text{EZP\_CS}}$ negation to next $\overline{\text{EZP\_CS}}$ assertion	$2 \times t_{\text{EZP\_CK}}$	—	ns
EP3	$\overline{\text{EZP\_CS}}$ input valid to EZP_CK high (setup)	15	—	ns
EP4	EZP_CK high to $\overline{\text{EZP\_CS}}$ input invalid (hold)	0.0	—	ns
EP5	EZP_D input valid to EZP_CK high (setup)	15	—	ns
EP6	EZP_CK high to EZP_D input invalid (hold)	0.0	—	ns
EP7	EZP_CK low to EZP_Q output valid (setup)	—	25	ns
EP8	EZP_CK low to EZP_Q output invalid (hold)	0.0	—	ns
EP9	$\overline{\text{EZP\_CS}}$ negation to EZP_Q tri-state	—	12	ns

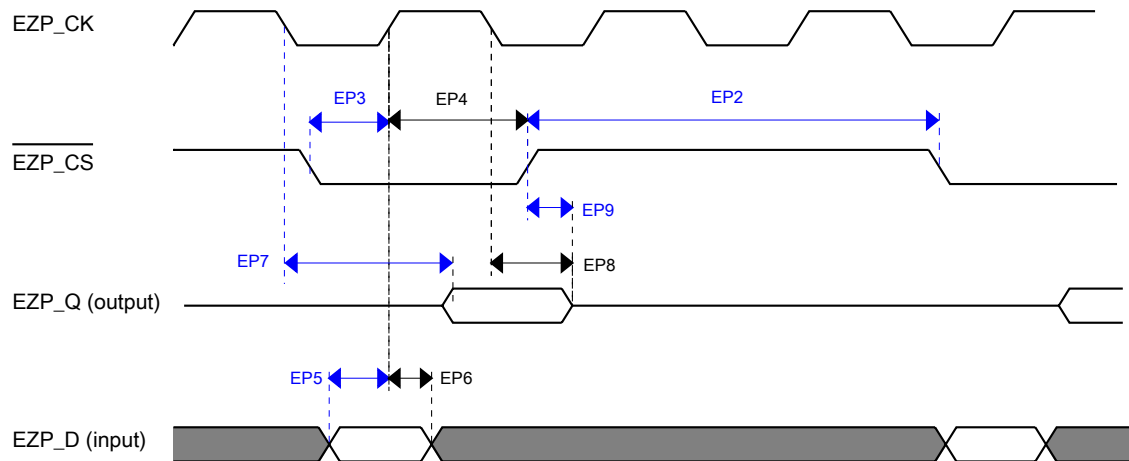

**Figure 5. EzPort Timing Diagram**

### 6.4.3 Mini-Flexbus Switching Specifications

All processor bus timings are synchronous; input setup/hold and output delay are given in respect to the rising edge of a reference clock, FB\_CLK. The FB\_CLK frequency may be the same as the internal system bus frequency or an integer divider of that frequency.

The following timing numbers indicate when data is latched or driven onto the external bus, relative to the Mini-Flexbus output clock (FB\_CLK). All other timing relationships can be derived from these values.

**Table 21. Flexbus switching specifications**

Num	Description	Min.	Max.	Unit	Notes
	Operating voltage	1.71	3.6	V	
	Frequency of operation	—	25	MHz	
FB1	Clock period	40	—	ns	
FB2	Address, data, and control output valid	—	20	ns	1
FB3	Address, data, and control output hold	1	—	ns	1
FB4	Data and $\overline{\text{FB\_T\bar{A}}}$ input setup	20	—	ns	2
FB5	Data and $\overline{\text{FB\_T\bar{A}}}$ input hold	10	—	ns	2

1. Specification is valid for all FB\_AD[31:0], FB\_CS $\bar{n}$ , FB\_OE, FB\_R/W, and FB\_TS.
2. Specification is valid for all FB\_AD[31:0].

#### Note

The following diagrams refer to signal names that may not be included on your particular device. Ignore these extraneous signals.

Also, ignore the AA=0 portions of the diagrams because this setting is not supported in the Mini-FlexBus.

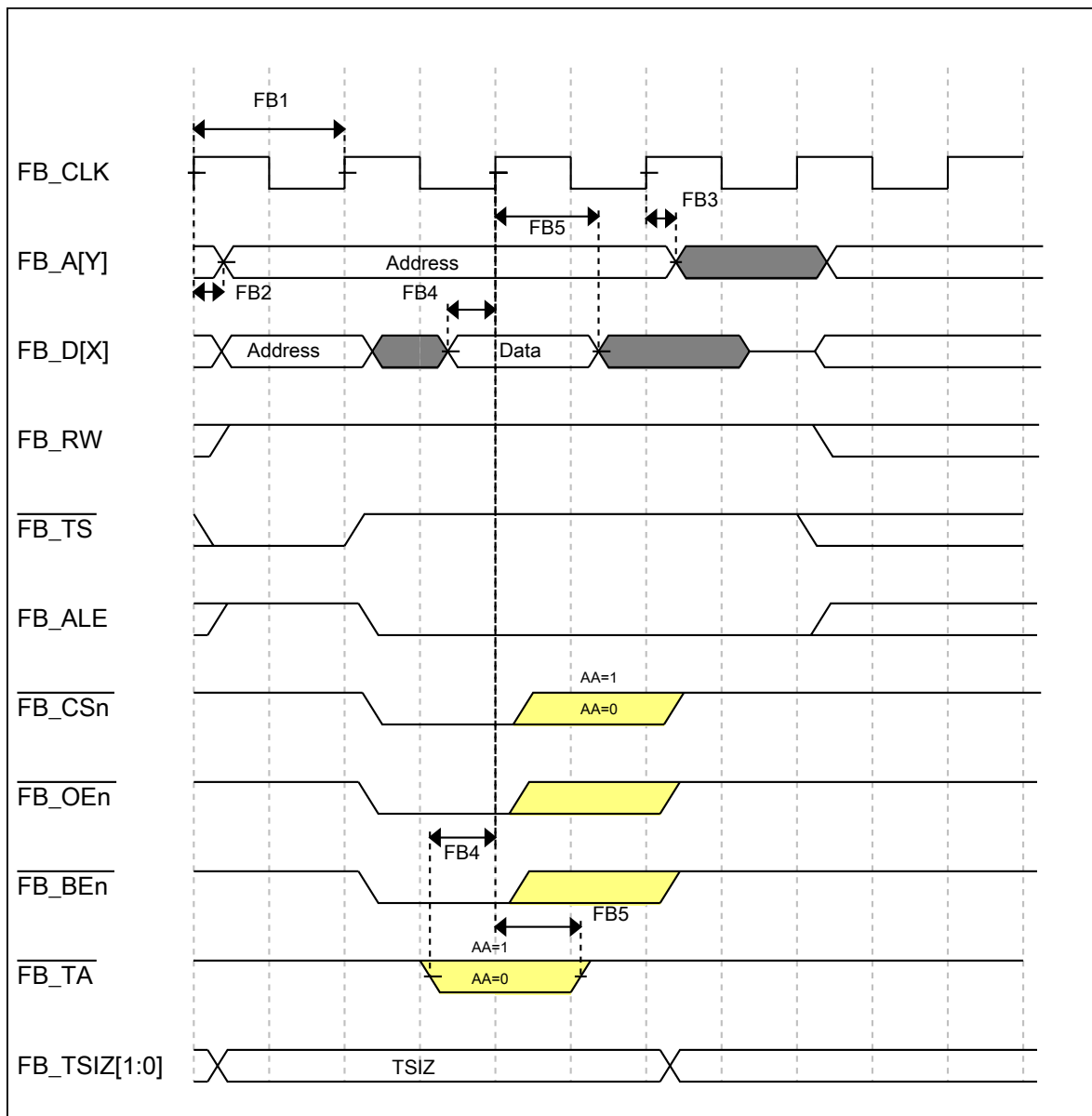

Figure 6. Mini-FlexBus read timing diagram

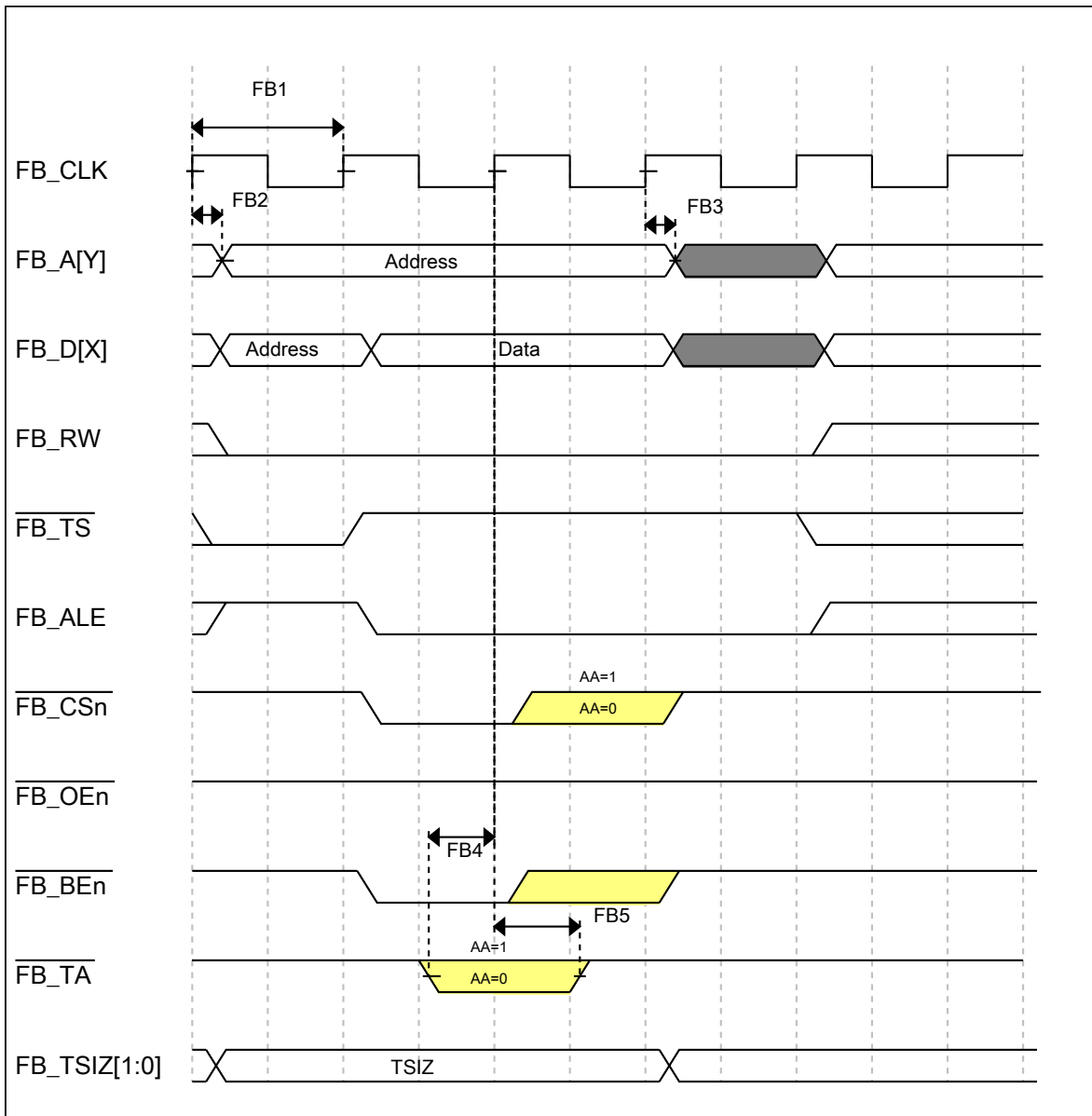

Figure 7. Mini-FlexBus write timing diagram

## 6.5 Security and integrity modules

There are no specifications necessary for the device's security and integrity modules.

## 6.6 Analog

### 6.6.1 ADC electrical specifications

All ADC channels meet the 12-bit single-ended accuracy specifications.

#### 6.6.1.1 12-bit ADC operating conditions

Table 22. 12-bit ADC operating conditions

Symbol	Description	Conditions	Min.	Typ. <sup>1</sup>	Max.	Unit	Notes
$V_{DDA}$	Supply voltage	Absolute	1.71	—	3.6	V	—
$\Delta V_{DDA}$	Supply voltage	Delta to $V_{DD}$ ( $V_{DD} - V_{DDA}$ )	-100	0	+100	mV	2
$\Delta V_{SSA}$	Ground voltage	Delta to $V_{SS}$ ( $V_{SS} - V_{SSA}$ )	-100	0	+100	mV	2
$V_{REFH}$	ADC reference voltage high		1.13	$V_{DDA}$	$V_{DDA}$	V	
$V_{REFL}$	ADC reference voltage low		$V_{SSA}$	$V_{SSA}$	$V_{SSA}$	V	
$V_{ADIN}$	Input voltage		$V_{REFL}$	—	$V_{REFH}$	V	—
$C_{ADIN}$	Input capacitance	• 8-bit / 10-bit / 12-bit modes	—	4	5	pF	—
$R_{ADIN}$	Input series resistance		—	2	5	k $\Omega$	—
$R_{AS}$	Analog source resistance (external)	12-bit modes $f_{ADCK} < 4$ MHz	—	—	5	k $\Omega$	3
$f_{ADCK}$	ADC conversion clock frequency	$\leq$ 12-bit mode	1.0	—	18.0	MHz	4
$C_{rate}$	ADC conversion rate	$\leq$ 12-bit modes No ADC hardware averaging Continuous conversions enabled, subsequent conversion time	20.000	—	818.330	Ksps	—

1. Typical values assume  $V_{DDA} = 3.0$  V, Temp = 25 °C,  $f_{ADCK} = 1.0$  MHz, unless otherwise stated. Typical values are for reference only, and are not tested in production.
2. DC potential difference.
3. This resistance is external to MCU. To achieve the best results, the analog source resistance must be kept as low as possible. The results in this data sheet were derived from a system that had  $< 8 \Omega$  analog source resistance. The  $R_{AS}/C_{AS}$  time constant should be kept to  $< 1$  ns.
4. To use the maximum ADC conversion clock frequency, CFG2[ADHSC] must be set and CFG1[ADLPC] must be clear.

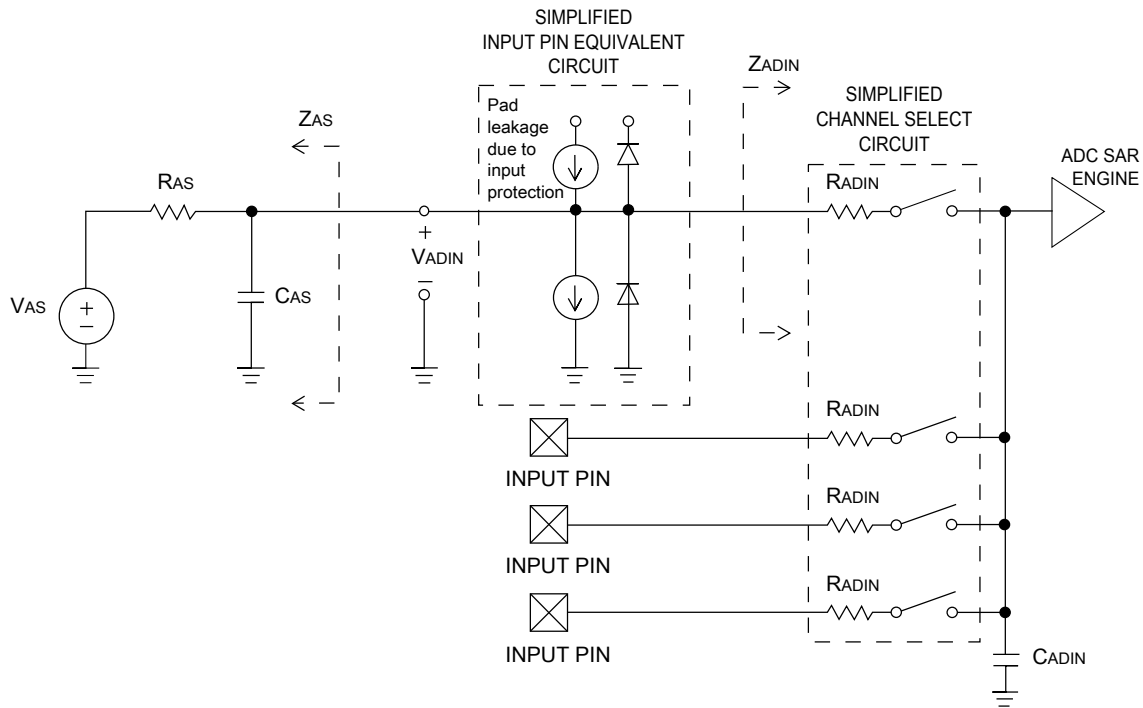

Figure 8. ADC input impedance equivalency diagram

### 6.6.1.2 12-bit ADC electrical characteristics

Table 23. 12-bit ADC characteristics ( $V_{REFH} = V_{DDA}$ ,  $V_{REFL} = V_{SSA}$ )

Symbol	Description	Conditions <sup>1</sup>	Min.	Typ. <sup>2</sup>	Max.	Unit	Notes
$I_{DDA\_ADC}$	Supply current		0.215	—	1.7	mA	3
$f_{ADACK}$	ADC asynchronous clock source	<ul style="list-style-type: none"> <li>ADLPC = 1, ADHSC = 0</li> <li>ADLPC = 1, ADHSC = 1</li> <li>ADLPC = 0, ADHSC = 0</li> <li>ADLPC = 0, ADHSC = 1</li> </ul>	1.2	2.4	3.9	MHz	$t_{ADACK} = 1/f_{ADACK}$
			3.0	4.0	7.3	MHz	
			2.4	5.2	6.1	MHz	
			4.4	6.2	9.5	MHz	
	Sample Time	See Reference Manual chapter for sample times					
TUE	Total unadjusted error	<ul style="list-style-type: none"> <li>12-bit modes</li> <li>&lt;12-bit modes</li> </ul>	—	±4	±6.8	LSB <sup>4</sup>	5
DNL	Differential non-linearity	<ul style="list-style-type: none"> <li>12-bit modes</li> <li>&lt;12-bit modes</li> </ul>	—	±0.7	-1.1 to +1.9	LSB <sup>4</sup>	5
INL	Integral non-linearity	<ul style="list-style-type: none"> <li>12-bit modes</li> <li>&lt;12-bit modes</li> </ul>	—	±1.0	-2.7 to +1.9	LSB <sup>4</sup>	5
			—	±0.5	-0.7 to +0.5		

Table continues on the next page...

**Table 23. 12-bit ADC characteristics ( $V_{REFH} = V_{DDA}$ ,  $V_{REFL} = V_{SSA}$ ) (continued)**

Symbol	Description	Conditions <sup>1</sup>	Min.	Typ. <sup>2</sup>	Max.	Unit	Notes
$E_{FS}$	Full-scale error	<ul style="list-style-type: none"> <li>12-bit modes</li> <li>&lt;12-bit modes</li> </ul>	—	-4	-5.4	LSB <sup>4</sup>	$V_{ADIN} = V_{DDA}$ <sup>5</sup>
$E_Q$	Quantization error	<ul style="list-style-type: none"> <li>12-bit modes</li> </ul>	—	—	±0.5	LSB <sup>4</sup>	
$E_{IL}$	Input leakage error		$I_{in} \times R_{AS}$			mV	$I_{in}$ = leakage current (refer to the MCU's voltage and current operating ratings)
	Temp sensor slope	-40°C to 25°C 25 to 105°C		1.695		mV/°C	6
$V_{TEMP25}$	Temp sensor voltage	25 °C		716		mV	6

- All accuracy numbers assume the ADC is calibrated with  $V_{REFH} = V_{DDA}$
- Typical values assume  $V_{DDA} = 3.0$  V, Temp = 25 °C,  $f_{ADCK} = 2.0$  MHz unless otherwise stated. Typical values are for reference only and are not tested in production.
- The ADC supply current depends on the ADC conversion clock speed, conversion rate and ADC\_CFG1[ADLPC] (low power). For lowest power operation, ADC\_CFG1[ADLPC] must be set, the ADC\_CFG2[ADHSC] bit must be clear with 1 MHz ADC conversion clock speed.
- 1 LSB =  $(V_{REFH} - V_{REFL})/2^N$
- ADC conversion clock < 16 MHz, Max hardware averaging (AVGE = %1, AVGS = %11)
- ADC conversion clock < 3 MHz

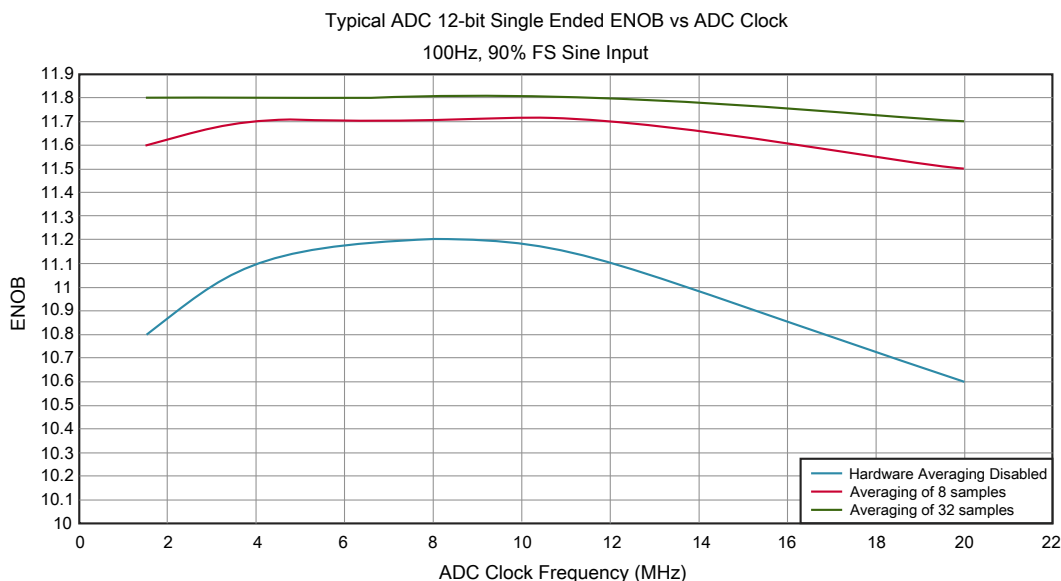
**Figure 9. Typical ENOB vs. ADC\_CLK for 12-bit single-ended mode**

## 6.6.2 CMP and 6-bit DAC electrical specifications

Table 24. Comparator and 6-bit DAC electrical specifications

Symbol	Description	Min.	Typ.	Max.	Unit
$V_{DD}$	Supply voltage	1.71	—	3.6	V
$I_{DDHS}$	Supply current, High-speed mode (EN=1, PMODE=1)	—	—	200	$\mu$ A
$I_{DDL S}$	Supply current, low-speed mode (EN=1, PMODE=0)	—	—	20	$\mu$ A
$V_{AIN}$	Analog input voltage	$V_{SS} - 0.3$	—	$V_{DD}$	V
$V_{AIO}$	Analog input offset voltage	—	—	20	mV
$V_H$	Analog comparator hysteresis <sup>1</sup> <ul style="list-style-type: none"> <li>• CR0[HYSTCTR] = 00</li> <li>• CR0[HYSTCTR] = 01</li> <li>• CR0[HYSTCTR] = 10</li> <li>• CR0[HYSTCTR] = 11</li> </ul>	—	5 10 20 30	—	mV mV mV mV
$V_{CMPOH}$	Output high	$V_{DD} - 0.5$	—	—	V
$V_{CMPOI}$	Output low	—	—	0.5	V
$t_{DHS}$	Propagation delay, high-speed mode (EN=1, PMODE=1)	20	50	200	ns
$t_{DLS}$	Propagation delay, low-speed mode (EN=1, PMODE=0)	80	250	600	ns
	Analog comparator initialization delay <sup>2</sup>	—	—	40	$\mu$ s
$I_{DAC6b}$	6-bit DAC current adder (enabled)	—	7	—	$\mu$ A
INL	6-bit DAC integral non-linearity	-0.5	—	0.5	LSB <sup>3</sup>
DNL	6-bit DAC differential non-linearity	-0.3	—	0.3	LSB

1. Typical hysteresis is measured with input voltage range limited to 0.6 to  $V_{DD} - 0.6$  V.
2. Comparator initialization delay is defined as the time between software writes to change control inputs (Writes to CMP\_DACCR[DACEN], CMP\_DACCR[VRSEL], CMP\_DACCR[VOSEL], CMP\_MUXCR[PSEL], and CMP\_MUXCR[MSEL]) and the comparator output settling to a stable level.
3. 1 LSB =  $V_{reference}/64$

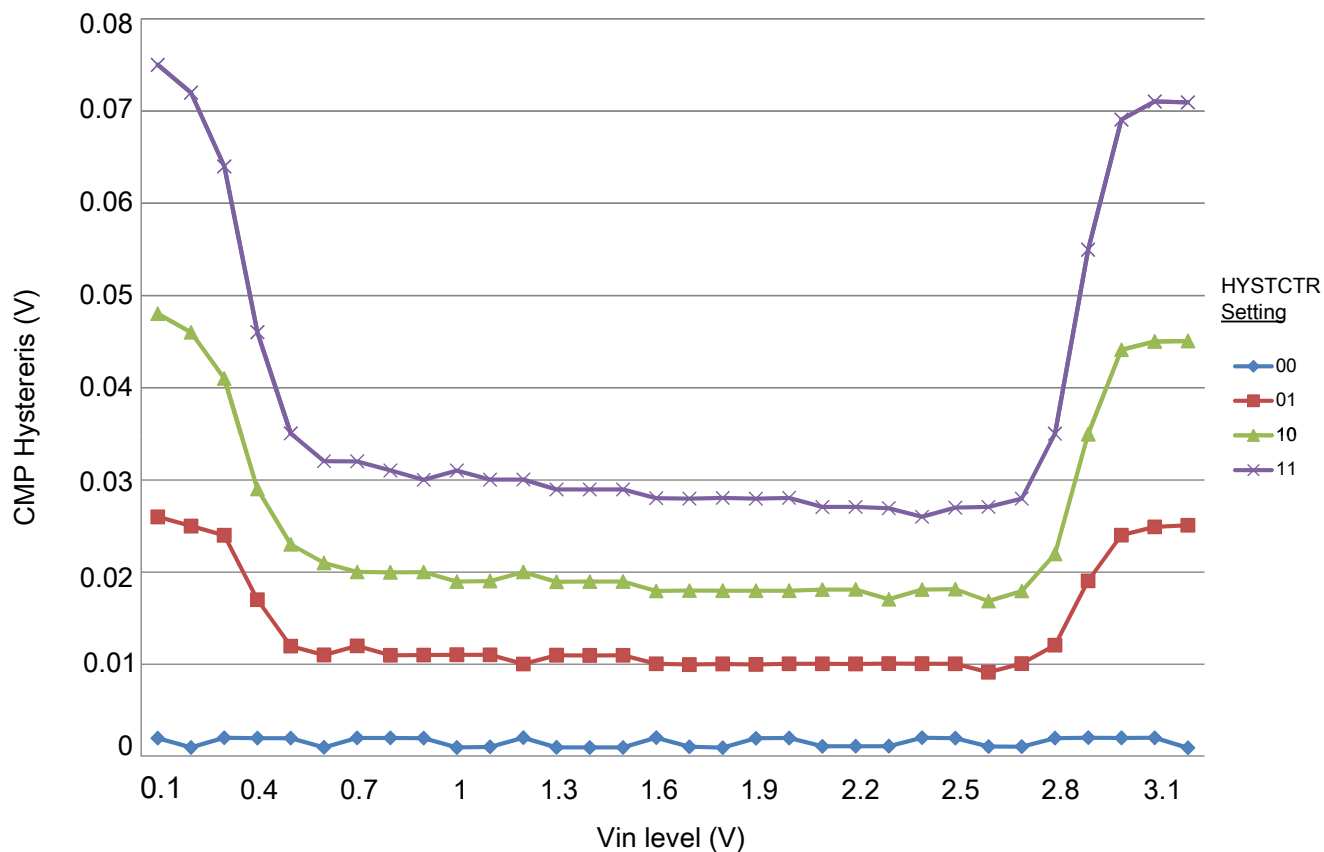

Figure 10. Typical hysteresis vs. Vin level (VDD = 3.3 V, PMODE = 0)

## 12-bit DAC electrical characteristics

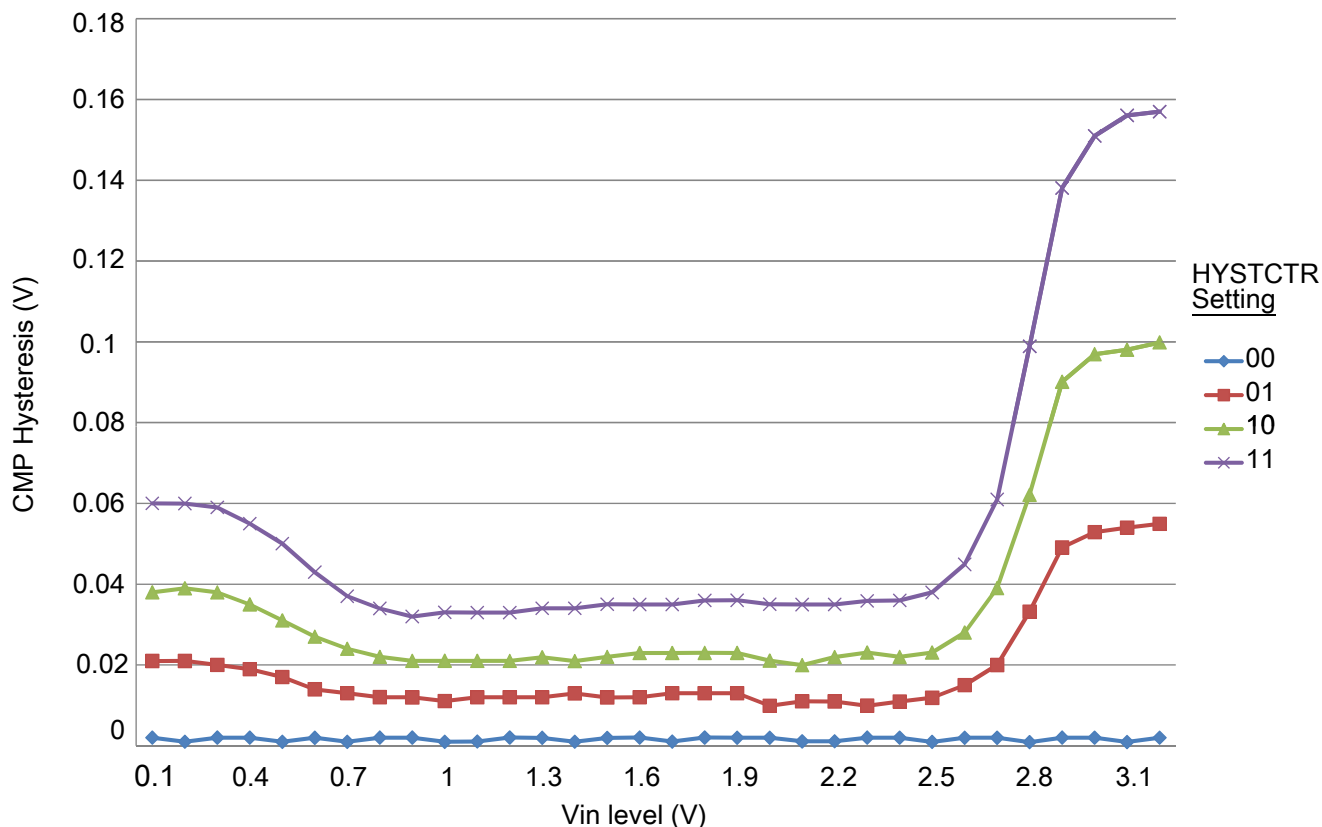

Figure 11. Typical hysteresis vs. Vin level (VDD = 3.3 V, PMODE = 1)

### 6.6.3 12-bit DAC electrical characteristics

#### 6.6.3.1 12-bit DAC operating requirements

Table 25. 12-bit DAC operating requirements

Symbol	Description	Min.	Max.	Unit	Notes
$V_{DDA}$	Supply voltage	1.71	3.6	V	
$V_{DACR}$	Reference voltage	1.13	3.6	V	1
$C_L$	Output load capacitance	—	100	pF	2
$I_L$	Output load current	—	1	mA	

1. The DAC reference can be selected to be  $V_{DDA}$  or  $V_{REFH}$ .
2. A small load capacitance (47 pF) can improve the bandwidth performance of the DAC.

### 6.6.3.2 12-bit DAC operating behaviors

Table 26. 12-bit DAC operating behaviors

Symbol	Description	Min.	Typ.	Max.	Unit	Notes
$I_{DDA\_DACLP}$	Supply current — low-power mode	—	—	450	$\mu\text{A}$	
$I_{DDA\_DACHP}$	Supply current — high-speed mode	—	—	1000	$\mu\text{A}$	
$t_{DACLP}$	Full-scale settling time (0x080 to 0xF7F) — low-power mode	—	100	200	$\mu\text{s}$	1
$t_{DACHP}$	Full-scale settling time (0x080 to 0xF7F) — high-power mode	—	15	30	$\mu\text{s}$	1
$t_{CCDACLP}$	Code-to-code settling time (0xBF8 to 0xC08) — low-power mode and high-speed mode	—	0.7	1	$\mu\text{s}$	1
$V_{dacoutl}$	DAC output voltage range low — high-speed mode, no load, DAC set to 0x000	—	—	100	mV	
$V_{dacouth}$	DAC output voltage range high — high-speed mode, no load, DAC set to 0xFFF	$V_{DACR} - 100$	—	$V_{DACR}$	mV	
INL	Integral non-linearity error — high speed mode	—	—	$\pm 8$	LSB	2
DNL	Differential non-linearity error — $V_{DACR} > 2\text{ V}$	—	—	$\pm 1$	LSB	3
DNL	Differential non-linearity error — $V_{DACR} = V_{REF\_OUT}$	—	—	$\pm 1$	LSB	4
$V_{OFFSET}$	Offset error	—	$\pm 0.4$	$\pm 0.8$	%FSR	5
$E_G$	Gain error	—	$\pm 0.1$	$\pm 0.6$	%FSR	5
PSRR	Power supply rejection ratio, $V_{DDA} \geq 2.4\text{ V}$	60	—	90	dB	
$T_{CO}$	Temperature coefficient offset voltage	—	3.7	—	$\mu\text{V}/\text{C}$	6
$T_{GE}$	Temperature coefficient gain error	—	0.000421	—	%FSR/C	
$R_{op}$	Output resistance (load = 3 k $\Omega$ )	—	—	250	$\Omega$	
SR	Slew rate -80h → F7Fh → 80h <ul style="list-style-type: none"> <li>• High power (SP<sub>HP</sub>)</li> <li>• Low power (SP<sub>LP</sub>)</li> </ul>	1.2 0.05	1.7 0.12	— —	V/ $\mu\text{s}$	
CT	Channel to channel cross talk	—	—	-80	dB	
BW	3dB bandwidth <ul style="list-style-type: none"> <li>• High power (SP<sub>HP</sub>)</li> <li>• Low power (SP<sub>LP</sub>)</li> </ul>	550 40	— —	— —	kHz	

1. Settling within  $\pm 1$  LSB
2. The INL is measured for 0 + 100 mV to  $V_{DACR} - 100$  mV
3. The DNL is measured for 0 + 100 mV to  $V_{DACR} - 100$  mV
4. The DNL is measured for 0 + 100 mV to  $V_{DACR} - 100$  mV with  $V_{DDA} > 2.4\text{ V}$
5. Calculated by a best fit curve from  $V_{SS} + 100$  mV to  $V_{DACR} - 100$  mV
6.  $V_{DDA} = 3.0\text{ V}$ , reference select set for  $V_{DDA}$  (DACx\_CO:DACRFS = 1), high power mode (DACx\_CO:LPEN = 0), DAC set to 0x800, temperature range is across the full range of the device

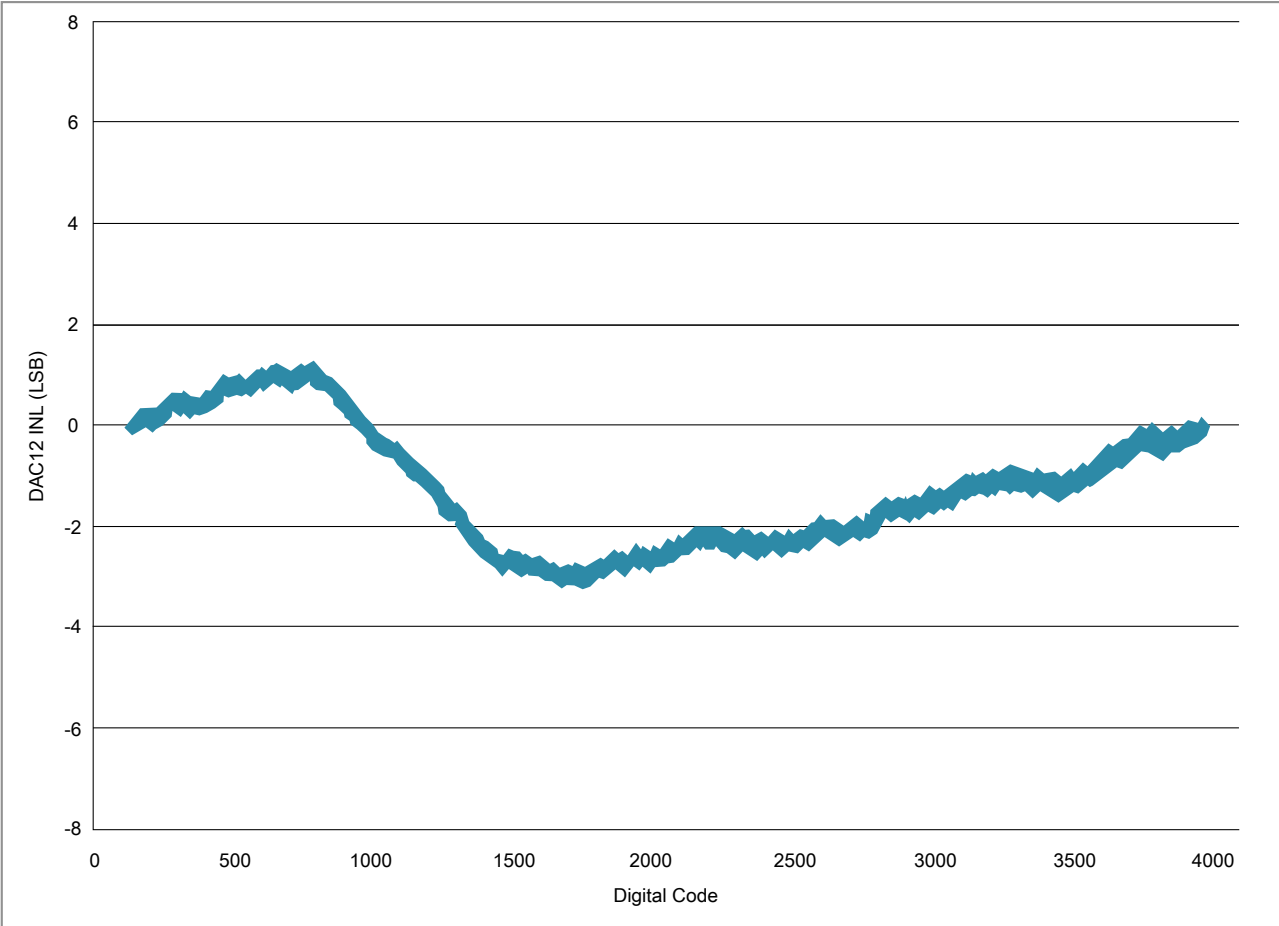

Figure 12. Typical INL error vs. digital code

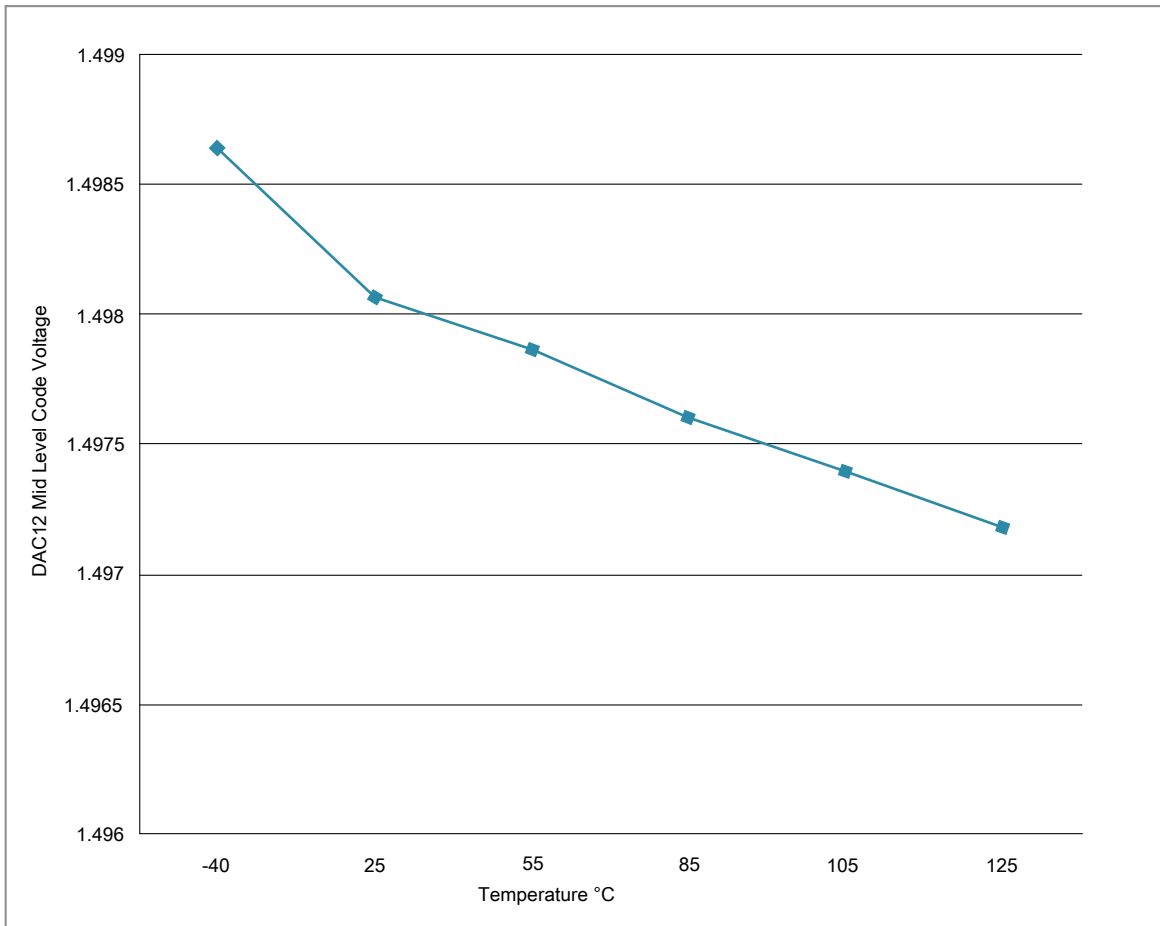

Figure 13. Offset at half scale vs. temperature

## 6.6.4 Voltage reference electrical specifications

Table 27. VREF full-range operating requirements

Symbol	Description	Min.	Max.	Unit	Notes
$V_{DDA}$	Supply voltage	1.71	3.6	V	—
$C_L$	Output load capacitance	100		nF	1

- $C_L$  must be connected to VREF\_OUT if the VREF\_OUT functionality is being used for either an internal or external reference.

Table 28. VREF full-range operating behaviors

Symbol	Description	Min.	Typ.	Max.	Unit	Notes
$V_{out}$	Voltage reference output with factory trim at nominal $V_{DDA}$ and temperature=25C	1.1965	1.2	1.2027	V	
$V_{out}$	Voltage reference output — factory trim	1.144	—	1.266	V	

Table continues on the next page...

**Table 28. VREF full-range operating behaviors (continued)**

Symbol	Description	Min.	Typ.	Max.	Unit	Notes
$V_{out}$	Voltage reference output — user trim	1.198	—	1.202	V	
$V_{step}$	Voltage reference trim step	—	0.5	—	mV	
$V_{tdrift}$	Temperature drift ( $V_{max} - V_{min}$ across the full temperature range)	—	—	80	mV	
$I_{bg}$	Bandgap only current	—	—	80	$\mu$ A	
$I_{hp}$	High-power buffer current	—	—	1	mA	
$\Delta V_{LOAD}$	Load regulation <ul style="list-style-type: none"> <li>• current = + 1.0 mA</li> <li>• current = - 1.0 mA</li> </ul>	—	2	—	mV	1
$T_{stup}$	Buffer startup time	—	—	100	$\mu$ s	—
$V_{vdrift}$	Voltage drift ( $V_{max} - V_{min}$ across the full voltage range)	—	2	—	mV	

1. Load regulation voltage is the difference between the VREF\_OUT voltage with no load vs. voltage with defined load

**Table 29. VREF limited-range operating requirements**

Symbol	Description	Min.	Max.	Unit	Notes
$T_A$	Temperature	0	50	$^{\circ}$ C	—

**Table 30. VREF limited-range operating behaviors**

Symbol	Description	Min.	Max.	Unit	Notes
$V_{out}$	Voltage reference output with factory trim	1.173	1.225	V	—

## 6.7 Timers

See [General Switching Specifications](#).

## 6.8 Communication interfaces

### 6.8.1 USB electrical specifications

The USB electricals for the USB On-the-Go module conform to the standards documented by the Universal Serial Bus Implementers Forum. For the most up-to-date standards, visit [usb.org](http://usb.org).

## NOTE

### 6.8.2 USB DCD electrical specifications

Table 31. USB0 DCD electrical specifications

Symbol	Description	Min.	Typ.	Max.	Unit
V <sub>DP_SRC</sub>	USB_DP source voltage (up to 250 $\mu$ A)	0.5	—	0.7	V
V <sub>LGC</sub>	Threshold voltage for logic high	0.8	—	2.0	V
I <sub>DP_SRC</sub>	USB_DP source current	7	10	13	$\mu$ A
I <sub>DM_SINK</sub>	USB_DM sink current	50	100	150	$\mu$ A
R <sub>DM_DWN</sub>	D- pulldown resistance for data pin contact detect	14.25	—	24.8	k $\Omega$
V <sub>DAT_REF</sub>	Data detect voltage	0.25	0.33	0.4	V

### 6.8.3 USB VREG electrical specifications

Table 32. USB VREG electrical specifications

Symbol	Description	Min.	Typ. <sup>1</sup>	Max.	Unit	Notes
V <sub>REGIN</sub>	Input supply voltage	2.7	—	5.5	V	
I <sub>DDon</sub>	Quiescent current — Run mode, load current equal zero, input supply (V <sub>REGIN</sub> ) > 3.6 V	—	120	186	$\mu$ A	
I <sub>DDstby</sub>	Quiescent current — Standby mode, load current equal zero	—	1.1	10	$\mu$ A	
I <sub>DDoff</sub>	Quiescent current — Shutdown mode <ul style="list-style-type: none"> <li>V<sub>REGIN</sub> = 5.0 V and temperature=25 °C</li> <li>Across operating voltage and temperature</li> </ul>	—	650	—	nA	
		—	—	4	$\mu$ A	
I <sub>LOADrun</sub>	Maximum load current — Run mode	—	—	120	mA	
I <sub>LOADstby</sub>	Maximum load current — Standby mode	—	—	1	mA	
V <sub>Reg33out</sub>	Regulator output voltage — Input supply (V <sub>REGIN</sub> ) > 3.6 V <ul style="list-style-type: none"> <li>Run mode</li> <li>Standby mode</li> </ul>	3	3.3	3.6	V	
		2.1	2.8	3.6	V	
V <sub>Reg33out</sub>	Regulator output voltage — Input supply (V <sub>REGIN</sub> ) < 3.6 V, pass-through mode	2.1	—	3.6	V	2
C <sub>OUT</sub>	External output capacitor	1.76	2.2	8.16	$\mu$ F	
ESR	External output capacitor equivalent series resistance	1	—	100	m $\Omega$	
I <sub>LIM</sub>	Short circuit current	—	290	—	mA	

1. Typical values assume V<sub>REGIN</sub> = 5.0 V, Temp = 25 °C unless otherwise stated.

2. Operating in pass-through mode: regulator output voltage equal to the input voltage minus a drop proportional to I<sub>Load</sub>.

### 6.8.4 SPI switching specifications

The Serial Peripheral Interface (SPI) provides a synchronous serial bus with master and slave operations. Many of the transfer attributes are programmable. The following tables provide timing characteristics for classic SPI timing modes. See the SPI chapter of the chip's Reference Manual for information about the modified transfer formats used for communicating with slower peripheral devices.

All timing is shown with respect to 20%  $V_{DD}$  and 70%  $V_{DD}$ , unless noted, as well as input signal transitions of 3 ns and a 50 pF maximum load on all SPI pins. All timing assumes slew rate control is disabled and high drive strength is enabled for SPI output pins.

**Table 33. SPI master mode timing**

Num.	Symbol	Description	Min.	Max.	Unit	Comment
1	$f_{op}$	Frequency of operation	$f_{BUS}/2048$	$f_{BUS}/2$	Hz	$f_{BUS}$ is the bus clock as defined in <a href="#">Table 8</a> .
2	$t_{SPSCK}$	SPSCK period	$2 \times t_{BUS}$	$2048 \times t_{BUS}$	ns	$t_{BUS} = 1/f_{BUS}$
3	$t_{Lead}$	Enable lead time	1/2	—	$t_{SPSCK}$	—
4	$t_{Lag}$	Enable lag time	1/2	—	$t_{SPSCK}$	—
5	$t_{WSPSCK}$	Clock (SPSCK) high or low time	$t_{BUS} - 30$	$1024 \times t_{BUS}$	ns	—
6	$t_{SU}$	Data setup time (inputs)	21	—	ns	—
7	$t_{HI}$	Data hold time (inputs)	0	—	ns	—
8	$t_v$	Data valid (after SPSCK edge)	—	25	ns	—
9	$t_{HO}$	Data hold time (outputs)	0	—	ns	—
10	$t_{RI}$	Rise time input	—	$t_{BUS} - 25$	ns	—
	$t_{FI}$	Fall time input				
11	$t_{RO}$	Rise time output	—	25	ns	—
	$t_{FO}$	Fall time output				

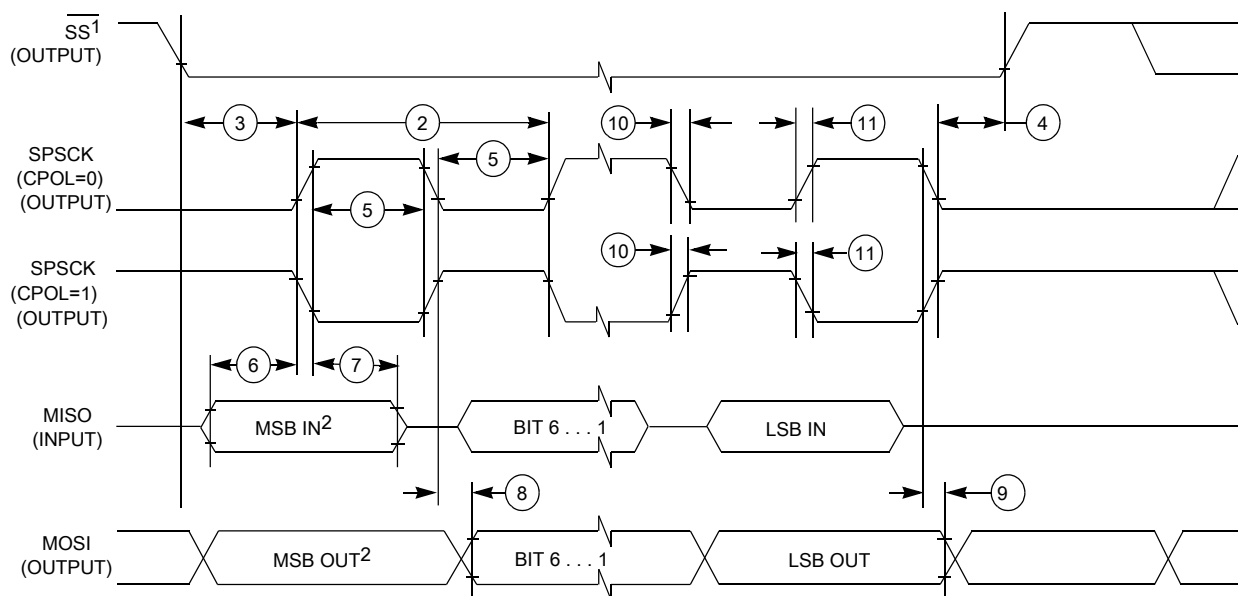

1. If configured as an output.
2. LSBF = 0. For LSBF = 1, bit order is LSB, bit 1, ..., bit 6, MSB.

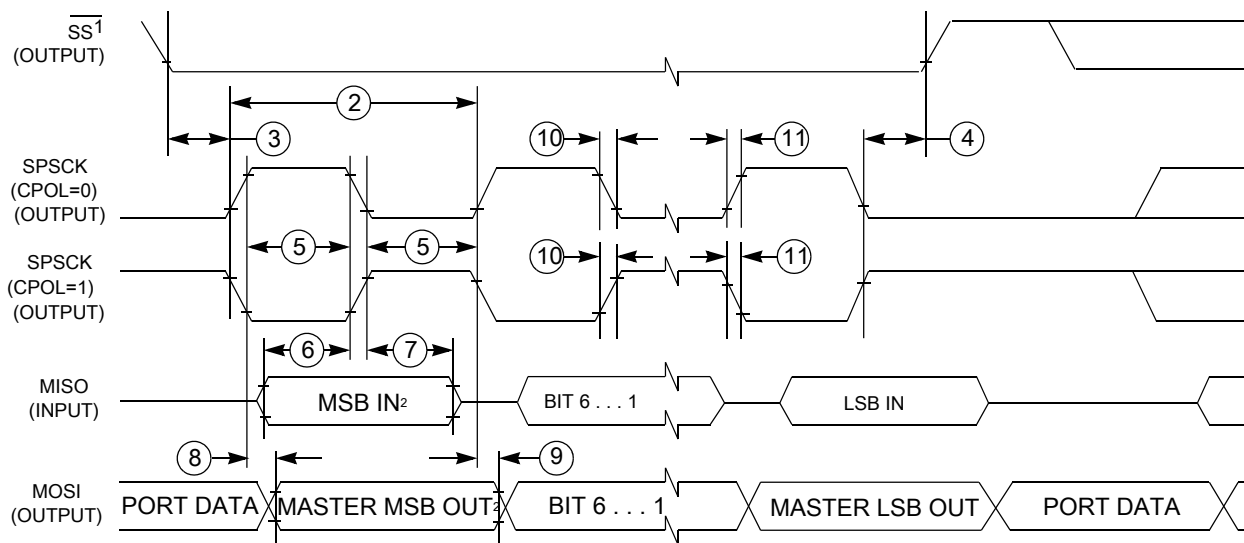
**Figure 14. SPI master mode timing (CPHA=0)**

1. If configured as output
2. LSBF = 0. For LSBF = 1, bit order is LSB, bit 1, ..., bit 6, MSB.

**Figure 15. SPI master mode timing (CPHA=1)**
**Table 34. SPI slave mode timing**

Num.	Symbol	Description	Min.	Max.	Unit	Comment
1	$f_{op}$	Frequency of operation	0	$f_{BUS}/4$	Hz	$f_{BUS}$ is the bus clock as defined in Table 8.
2	$t_{SPSCK}$	SPSCCK period	$4 \times t_{BUS}$	—	ns	$t_{BUS} = 1/f_{BUS}$

Table continues on the next page...

**Table 34. SPI slave mode timing (continued)**

Num.	Symbol	Description	Min.	Max.	Unit	Comment
3	$t_{Lead}$	Enable lead time	1	—	$t_{BUS}$	—
4	$t_{Lag}$	Enable lag time	1	—	$t_{BUS}$	—
5	$t_{WSPSCK}$	Clock (SPSCK) high or low time	$t_{BUS} - 30$	—	ns	—
6	$t_{SU}$	Data setup time (inputs)	19.5	—	ns	—
7	$t_{HI}$	Data hold time (inputs)	0	—	ns	—
8	$t_a$	Slave access time	—	$t_{BUS}$	ns	Time to data active from high-impedance state
9	$t_{dis}$	Slave MISO disable time	—	$t_{BUS}$	ns	Hold time to high-impedance state
10	$t_v$	Data valid (after SPSCK edge)	—	27	ns	—
11	$t_{HO}$	Data hold time (outputs)	0	—	ns	—
12	$t_{RI}$	Rise time input	—	$t_{BUS} - 25$	ns	—
	$t_{FI}$	Fall time input				
13	$t_{RO}$	Rise time output	—	25	ns	—
	$t_{FO}$	Fall time output				

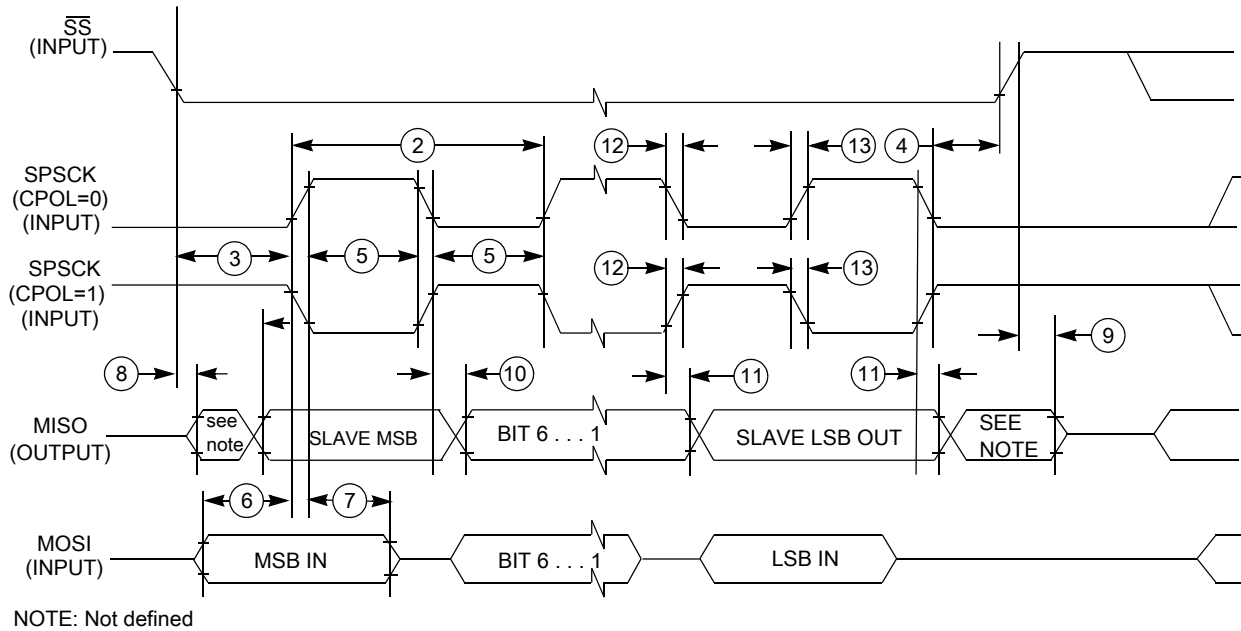

**Figure 16. SPI slave mode timing (CPHA=0)**

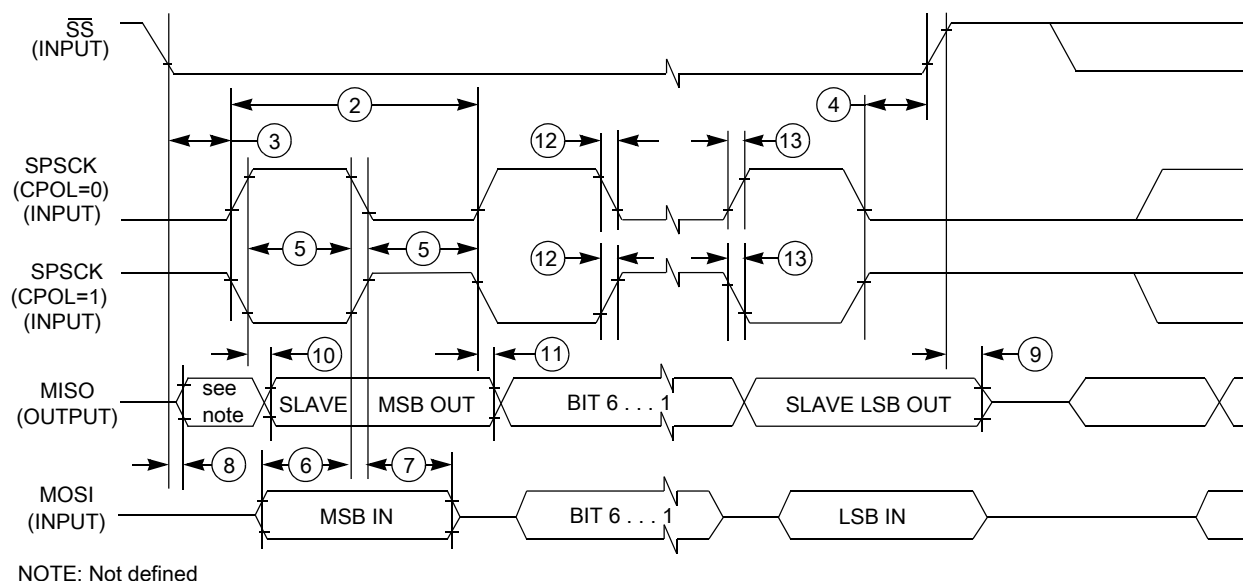

**Figure 17. SPI slave mode timing (CPHA=1)**

### 6.8.5 I2S/SAI Switching Specifications

This section provides the AC timing for the I2S/SAI module in master mode (clocks are driven) and slave mode (clocks are input). All timing is given for noninverted serial clock polarity (TCR2[BCP] is 0, RCR2[BCP] is 0) and a noninverted frame sync (TCR4[FSP] is 0, RCR4[FSP] is 0). If the polarity of the clock and/or the frame sync have been inverted, all the timing remains valid by inverting the bit clock signal (BCLK) and/or the frame sync (FS) signal shown in the following figures. All timing shown is also with respect to input signal transitions of 3 ns and a 50 pF maximum load.

**Table 35. I2S/SAI master mode timing**

Num.	Characteristic	Min.	Max.	Unit
	Operating voltage	1.71	3.6	V
S1	I2S_MCLK cycle time <sup>1</sup>	40	—	ns
S2	I2S_MCLK (as an input) pulse width high/low	45%	55%	MCLK period
S3	I2S_TX_BCLK/I2S_RX_BCLK cycle time (output)	80	—	ns
S4	I2S_TX_BCLK/I2S_RX_BCLK pulse width high/low	45%	55%	BCLK period
S5	I2S_TX_BCLK/I2S_RX_BCLK to I2S_TX_FS/ I2S_RX_FS output valid	—	15	ns
S6	I2S_TX_BCLK/I2S_RX_BCLK to I2S_TX_FS/ I2S_RX_FS output invalid	0	—	ns
S7	I2S_TX_BCLK to I2S_TXD valid	—	15	ns
S8	I2S_TX_BCLK to I2S_TXD invalid	0	—	ns
S9	I2S_RXD/I2S_RX_FS input setup before I2S_RX_BCLK	25	—	ns

Table continues on the next page...

**Table 35. I2S/SAI master mode timing (continued)**

Num.	Characteristic	Min.	Max.	Unit
S10	I2S_RXD/I2S_RX_FS input hold after I2S_RX_BCLK	0	—	ns
S11	I2S_TX_FS input assertion to I2S_TXD output valid <sup>2</sup>	—	21	ns

1. This parameter is limited in VLPx modes.
2. Applies to first bit in each frame and only if the TCR4[FSE] bit is clear

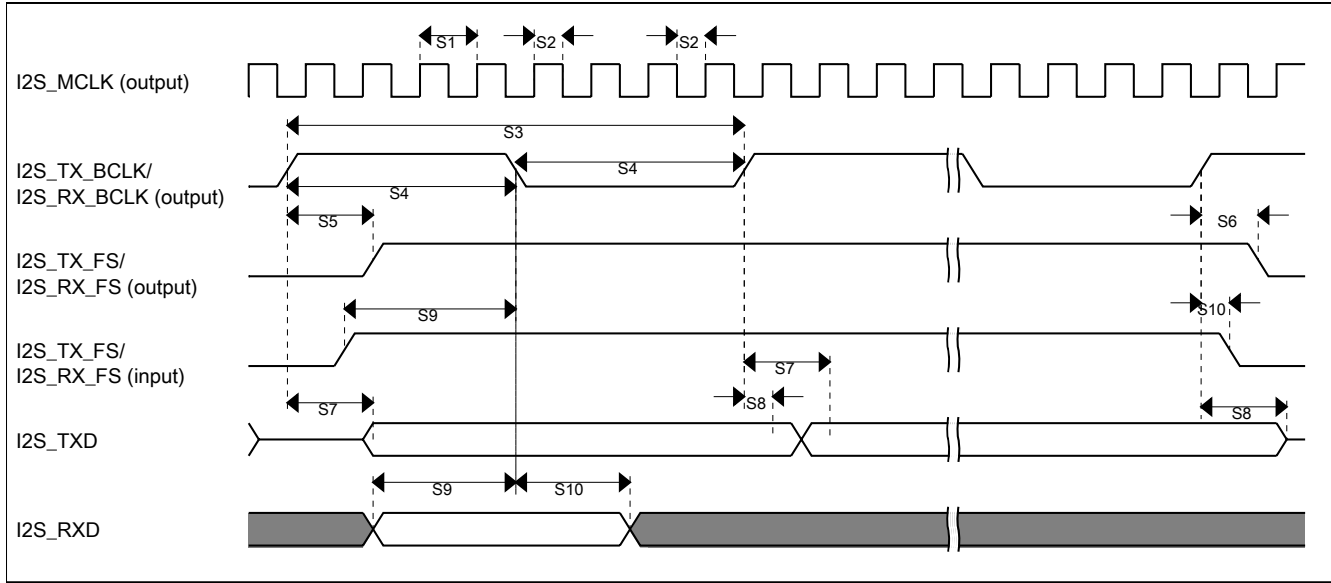

**Figure 18. I2S/SAI timing — master modes**

**Table 36. I2S/SAI slave mode timing**

Num.	Characteristic	Min.	Max.	Unit
	Operating voltage	1.71	3.6	V
S11	I2S_TX_BCLK/I2S_RX_BCLK cycle time (input)	80	—	ns
	I2S_TX_BCLK cycle time (input)	160	—	
S12	I2S_TX_BCLK/I2S_RX_BCLK pulse width high/low (input)	45%	55%	MCLK period
S13	I2S_TX_FS/I2S_RX_FS input setup before I2S_TX_BCLK/I2S_RX_BCLK	10	—	ns
S14	I2S_TX_FS/I2S_RX_FS input hold after I2S_TX_BCLK/I2S_RX_BCLK	2	—	ns
S15	I2S_TX_BCLK to I2S_TXD/I2S_TX_FS output valid	—	29	ns
S16	I2S_TX_BCLK to I2S_TXD/I2S_TX_FS output invalid	0	—	ns
S17	I2S_RXD setup before I2S_RX_BCLK	10	—	ns
S18	I2S_RXD hold after I2S_RX_BCLK	2	—	ns
S19	I2S_TX_FS input assertion to I2S_TXD output valid <sup>1</sup>	—	21	ns

1. Applies to first bit in each frame and only if the TCR4[FSE] bit is clear

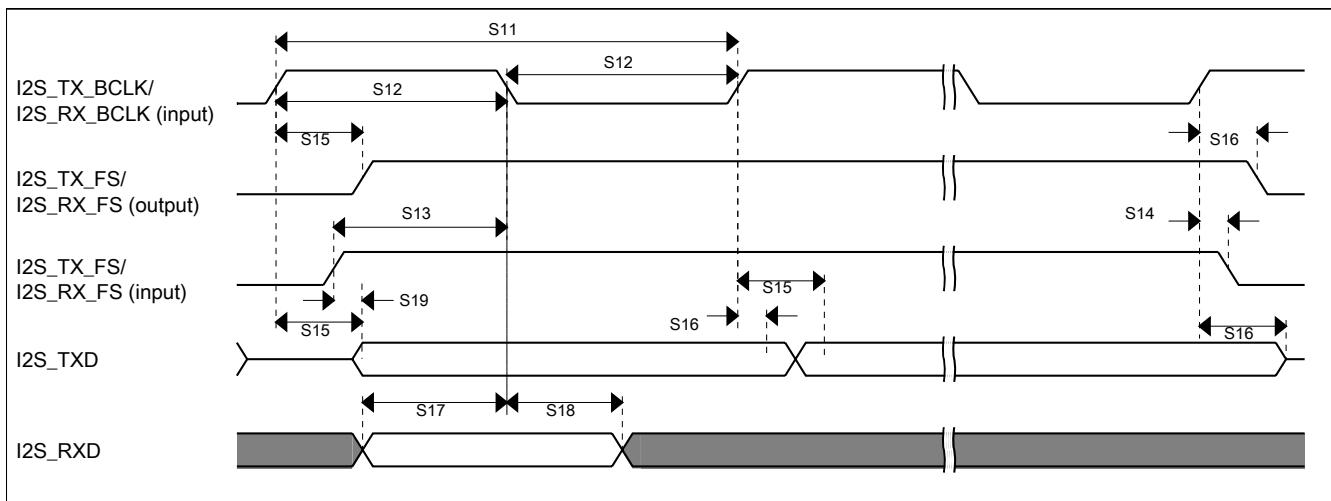

Figure 19. I2S/SAI timing — slave modes

## 6.9 Human-machine interfaces (HMI)

### 6.9.1 TSI electrical specifications

Table 37. TSI electrical specifications

Symbol	Description	Min.	Typ.	Max.	Unit	Notes
$V_{DDTSI}$	Operating voltage	1.71	—	3.6	V	
$C_{ELE}$	Target electrode capacitance range	1	20	500	pF	1
$f_{REFmax}$	Reference oscillator frequency	—	5.5	14	MHz	2
$f_{ELEmax}$	Electrode oscillator frequency	—	0.5	4.0	MHz	3
$C_{REF}$	Internal reference capacitor	0.5	1	1.2	pF	
$V_{DELTA}$	Oscillator delta voltage	100	600	760	mV	4
$I_{REF}$	Reference oscillator current source base current <ul style="list-style-type: none"> <li>• 1uA setting (REFCHRG=0)</li> <li>• 32uA setting (REFCHRG=31)</li> </ul>	— —	1.133 36	1.5 50	$\mu$ A	3, 5
$I_{ELE}$	Electrode oscillator current source base current <ul style="list-style-type: none"> <li>• 1uA setting (EXTCHRG=0)</li> <li>• 32uA setting (EXTCHRG=31)</li> </ul>	— —	1.133 36	1.5 50	$\mu$ A	3, 6
Pres5	Electrode capacitance measurement precision	—	8.3333	38400	fF/count	7
Pres20	Electrode capacitance measurement precision	—	8.3333	38400	fF/count	8
Pres100	Electrode capacitance measurement precision	—	8.3333	38400	fF/count	9
MaxSens	Maximum sensitivity	0.003	12.5	—	fF/count	10
Res	Resolution	—	—	16	bits	
$T_{Con20}$	Response time @ 20 pF	8	15	25	$\mu$ s	11
$I_{TSI\_RUN}$	Current added in run mode	—	55	—	$\mu$ A	
$I_{TSI\_LP}$	Low power mode current adder	—	1.3	2.5	$\mu$ A	12

## Dimensions

1. The TSI module is functional with capacitance values outside this range. However, optimal performance is not guaranteed.
2. CAPTRM=7, DELVOL=7, and fixed external capacitance of 20 pF.
3. CAPTRM=0, DELVOL=2, and fixed external capacitance of 20 pF.
4. CAPTRM=0, EXTCHRG=9, and fixed external capacitance of 20 pF.
5. The programmable current source value is generated by multiplying the SCANC[REFCHRG] value and the base current.
6. The programmable current source value is generated by multiplying the SCANC[EXTCHRG] value and the base current.
7. Measured with a 5 pF electrode, reference oscillator frequency of 10 MHz, PS = 128, NSCN = 8; I<sub>ext</sub> = 16.
8. Measured with a 20 pF electrode, reference oscillator frequency of 10 MHz, PS = 128, NSCN = 2; I<sub>ext</sub> = 16.
9. Measured with a 20 pF electrode, reference oscillator frequency of 10 MHz, PS = 16, NSCN = 3; I<sub>ext</sub> = 16.
10. Sensitivity defines the minimum capacitance change when a single count from the TSI module changes, it is equal to  $(C_{ref} * I_{ext}) / (I_{ref} * PS * NSCN)$ . Sensitivity depends on the configuration used. The typical value listed is based on the following configuration: I<sub>ext</sub> = 5 μA, EXTCHRG = 4, PS = 128, NSCN = 2, I<sub>ref</sub> = 16 μA, REFCHRG = 15, C<sub>ref</sub> = 1.0 pF. The minimum sensitivity describes the smallest possible capacitance that can be measured by a single count (this is the best sensitivity but is described as a minimum because it's the smallest number). The minimum sensitivity parameter is based on the following configuration: I<sub>ext</sub> = 1 μA, EXTCHRG = 0, PS = 128, NSCN = 32, I<sub>ref</sub> = 32 μA, REFCHRG = 31, C<sub>ref</sub> = 0.5 pF
11. Time to do one complete measurement of the electrode. Sensitivity resolution of 0.0133 pF, PS = 0, NSCN = 0, 1 electrode, DELVOL = 2, EXTCHRG = 15.
12. CAPTRM=7, DELVOL=2, REFCHRG=0, EXTCHRG=4, PS=7, NSCN=0F, LPSCNITV=F, LPO is selected (1 kHz), and fixed external capacitance of 20 pF. Data is captured with an average of 7 periods window.

## 7 Dimensions

### 7.1 Obtaining package dimensions

Package dimensions are provided in package drawings.

To find a package drawing, go to [www.freescale.com](http://www.freescale.com) and perform a keyword search for the drawing's document number:

If you want the drawing for this package	Then use this document number
32-pin QFN	98ARE10566D
44-pin Laminate QFN	98ASA00239D
48-pin LQFP	98ASH00962A
64-pin LQFP	98ASS23234W

## 8 Pinout

### 8.1 Signal Multiplexing and Pin Assignments

The following table shows the signals available on each pin and the locations of these pins on the devices supported by this document. The Port Mux Control module is responsible for selecting which ALT functionality is available on each pin.

### NOTE

- On PTB0, EZP\_MS\_b is active only during reset. Refer to the detailed boot description.
- PTC1 is open drain.

64-pin	48-pin	44-pin	32-pin	Default	ALT0	ALT1	ALT2	ALT3	ALT4	ALT5	ALT6	ALT7	EzPort
—	—	—	EP	Exposed Pads	Exposed die attach pad. Connection to VSS is recommended.								
—	—	EP	—	VSS	Exposed die attach pads are connected internally to VSS. External connection to VSS is recommended.								
1	—	—	—	VDD	VDD								
2	—	—	—	VSS	VSS								
3	—	—	—	Disabled	Disabled	PTC6	UART0_TX	I2C0_SCL	RGPIO6	SPI1_MOSI	FbA_AD11		
4	—	—	—	Disabled	Disabled	PTC7	UART0_RX	I2C0_SDA	RGPIO7	SPI1_MISO	FbA_AD12		
5	1	—	—	Disabled	Disabled	PTD0	UART0_CTS_b	I2C1_SDA	RGPIO8	SPI1_SCLK	FbA_AD13	I2S0_MCLK/ I2S0_CLKIN	
6	2	—	—	Disabled	Disabled	PTD1	UART0_RTS_b	I2C1_SCL	RGPIO9	SPI1_SS	FbA_AD14	I2S0_RX_BCLK	
7	3	1	1	Disabled	Disabled	PTA0		I2C2_SCL	FTM1_CH0	SPI0_SS	FbA_AD15	I2S0_RX_FS	
8	4	2	2	Disabled	Disabled	PTA1		I2C2_SDA	FTM1_CH1		FbA_AD16	I2S0_RXD	
9	5	3	3	Disabled	Disabled	PTA2	UART1_TX		FTM1_CH2	SPI1_SS			
10	6	4	4	Disabled	Disabled	PTA3	UART1_RX		FTM1_CH3	SPI1_SCLK		I2S0_TX_BCLK	EZP_CLK
11	7	5	5	ADC0_SE2	ADC0_SE2	PTA4	UART1_CTS_b	I2C2_SCL	FTM1_CH4	SPI1_MISO		I2S0_TX_FS	EZP_DI
12	8	6	6	ADC0_SE3	ADC0_SE3	PTA5	UART1_RTS_b	I2C2_SDA	FTM1_CH5	SPI1_MOSI	CLKOUT	I2S0_TXD	EZP_DO
13	9	7	7	VDDA	VDDA								
14	10	8	—	VREFH	VREFH								
15	11	9	—	VREF_OUT	VREF_OUT								
16	12	10	—	VREFL	VREFL								
17	13	11	8	VSSA	VSSA								
18	14	12	9	DAC0_OUT	DAC0_OUT								
19	15	13	10	VREGIN	VREGIN								
20	16	14	11	VOUT33	VOUT33								
21	17	15	12	USB0_DM	USB0_DM								

**Pinout**

64-pin	48-pin	44-pin	32-pin	Default	ALT0	ALT1	ALT2	ALT3	ALT4	ALT5	ALT6	ALT7	EzPort
22	18	16	13	USB0_DP	USB0_DP								
23	19	17	14	VSS	VSS								
24	20	18	—	VDD	VDD								
25	21	19	15	ADC0_SE8/ TSIO_CH0	ADC0_SE8/ TSIO_CH0	PTA6		LPTMR_ ALT1	FTM_FLT1	FbA_D7	FbA_AD17		
26	—	—	—	ADC0_SE9/ TSIO_CH1	ADC0_SE9/ TSIO_CH1	PTD2	FTM0_QD_ PHA	RGPIO10	FTM0_CH0				
27	22	20	—	ADC0_SE10/ TSIO_CH2	ADC0_SE10/ TSIO_CH2	PTD3	FTM0_QD_ PHB	RGPIO11	FTM0_CH1	FbA_D6	FbA_AD0		
28	—	—	—	ADC0_SE11/ TSIO_CH3	ADC0_SE11/ TSIO_CH3	PTD4		RGPIO12			FbA_D7		
29	—	—	—	ADC0_SE12/ TSIO_CH4	ADC0_SE12/ TSIO_CH4	PTD5		RGPIO13			FbA_D6		
30	23	21	16	ADC0_SE13/ TSIO_CH5	ADC0_SE13/ TSIO_CH5	PTA7	UART0_TX		FTM0_QD_ PHA		FbA_D5		
31	24	22	—	ADC0_SE14/ TSIO_CH6	ADC0_SE14/ TSIO_CH6	PTD6	UART0_RX	RGPIO14			FbA_D4		
32	—	—	—	ADC0_SE15/ TSIO_CH7	ADC0_SE15/ TSIO_CH7	PTD7	UART0_ CTS_b	I2C3_SCL	RGPIO15		FbA_D3		
33	—	—	—	TSIO_CH8	TSIO_CH8	PTE0	UART0_ RTS_b	I2C3_SDA			FbA_D2		
34	—	—	—	TSIO_CH9	TSIO_CH9	PTE1	SPI0_SS		FTM_FLT0		FbA_D1		
35	25	23	17	IRQ/ EZP_MS_b	Disabled	PTB0		I2C0_SCL		IRQ/ EZP_MS_b			EZP_CS_b
36	26	24	18	TSIO_CH10	TSIO_CH10	PTB1	SPI0_SCLK	I2C0_SDA	FTM_FLT2	LPTMR_ ALT2	FTM0_QD_ PHB	FB_CLKOUT	
37	—	—	—	TSIO_CH11	TSIO_CH11	PTE2		I2C3_SCL			FbA_D0		
38	—	—	—	ADC0_SE16/ TSIO_CH12	ADC0_SE16/ TSIO_CH12	PTE3	SPI0_MOSI	I2C3_SDA			FbA_OE_b		
39	27	25	19	ADC0_SE17/ TSIO_CH13	ADC0_SE17/ TSIO_CH13	PTB2	SPI0_MISO				FbA_CS0_b		
40	28	26	20	ADC0_SE18/ TSIO_CH14	ADC0_SE18/ TSIO_CH14	PTB3	SPI0_MOSI			FbA_CS1_b	FbA_ALE		
41	29	—	—	ADC0_SE19/ TSIO_CH15	ADC0_SE19/ TSIO_CH15	PTE4	UART0_ RTS_b	LPTMR_ ALT3	SPI1_SS		FbA_AD1		
42	30	—	—	ADC0_SE20	ADC0_SE20	PTE5	UART0_ CTS_b	I2C1_SCL	SPI1_SCLK		FbA_AD2		
43	—	—	—	ADC0_SE21	ADC0_SE21	PTE6	UART0_RX	I2C1_SDA	SPI1_MISO		FbA_AD3		
44	31	27	—	ADC0_SE22	ADC0_SE22	PTE7	UART0_TX	PDB0_ EXTRG	SPI1_MOSI	FbA_RW_b	FbA_AD4		
45	32	28	21	BKGD/ MS	Disabled	PTB4	BKGD/ MS						
46	33	29	22	XTAL2	XTAL2	PTB5							
47	34	30	23	EXTAL2	EXTAL2	PTB6							
48	35	31	24	VDD	VDD								
49	36	32	25	VSS	VSS								

64-pin	48-pin	44-pin	32-pin	Default	ALT0	ALT1	ALT2	ALT3	ALT4	ALT5	ALT6	ALT7	EzPort
50	37	33	26	EXTAL1	EXTAL1	PTB7		I2C1_SDA	TMR_CLKIN1				
51	38	34	27	XTAL1	XTAL1	PTC0		I2C1_SCL	TMR_CLKIN0	RGPIO0			
52	39	35	28	RESET_b	Disabled	PTC1	RESET_b						
53	—	—	—	CMP0_IN0	CMP0_IN0	PTF0	SPI0_SS				FBa_AD5		
54	—	—	—	Disabled	Disabled	PTF1	SPI0_SCLK			CMP0_OUT	FBa_AD6		
55	—	—	—	CMP0_IN1	CMP0_IN1	PTF2	SPI0_MISO				FBa_AD7		
56	40	36	—	CMP0_IN2	CMP0_IN2	PTF3	SPI0_MOSI			RGPIO1	FBa_AD8	I2S0_TXD	
57	41	37	29	CMP0_IN3	CMP0_IN3	PTC2	UART1_RTS_b	SPI1_SS		RGPIO2	FBa_AD18	I2S0_TX_FS	
58	42	38	—	Disabled	Disabled	PTF4	UART1_CTS_b	SPI1_SCLK		FBa_D3	FBa_AD19	I2S0_TX_BCLK	
59	43	39	—	Disabled	Disabled	PTF5	UART1_RX	SPI1_MISO		FBa_D2	FBa_RW_b	I2S0_RXD	
60	44	40	—	Disabled	Disabled	PTF6	UART1_TX	SPI1_MOSI		FBa_D1	FBa_AD9	I2S0_RX_FS	
61	45	41	—	Disabled	Disabled	PTF7	UART0_RTS_b		SPI0_SS	FBa_D0	FBa_AD10	I2S0_RX_BCLK	
62	46	42	30	Disabled	Disabled	PTC3	UART0_CTS_b	RGPIO3	SPI0_SCLK	CLKOUT	USB_CLKIN	I2S0_MCLK/ I2S0_CLKIN	
63	47	43	31	Disabled	Disabled	PTC4	UART0_RX	RGPIO4	SPI0_MISO	PDB0_EXTRG	USB_SOF_PULSE		
64	48	44	32	Disabled	Disabled	PTC5	UART0_TX	RGPIO5	SPI0_MOSI	CMT_IRO			

## 8.2 Pinout diagrams

The following diagrams show pinouts for the 64-pin, 48-pin, 44-pin, and 32-pin packages. These diagrams are representations for ease of reference. See the package drawings for mechanical details.

For each pin, the diagrams show the default function or (when disabled is the default) the ALT1 signal for a GPIO function. However, many signals may be multiplexed onto a single pin.

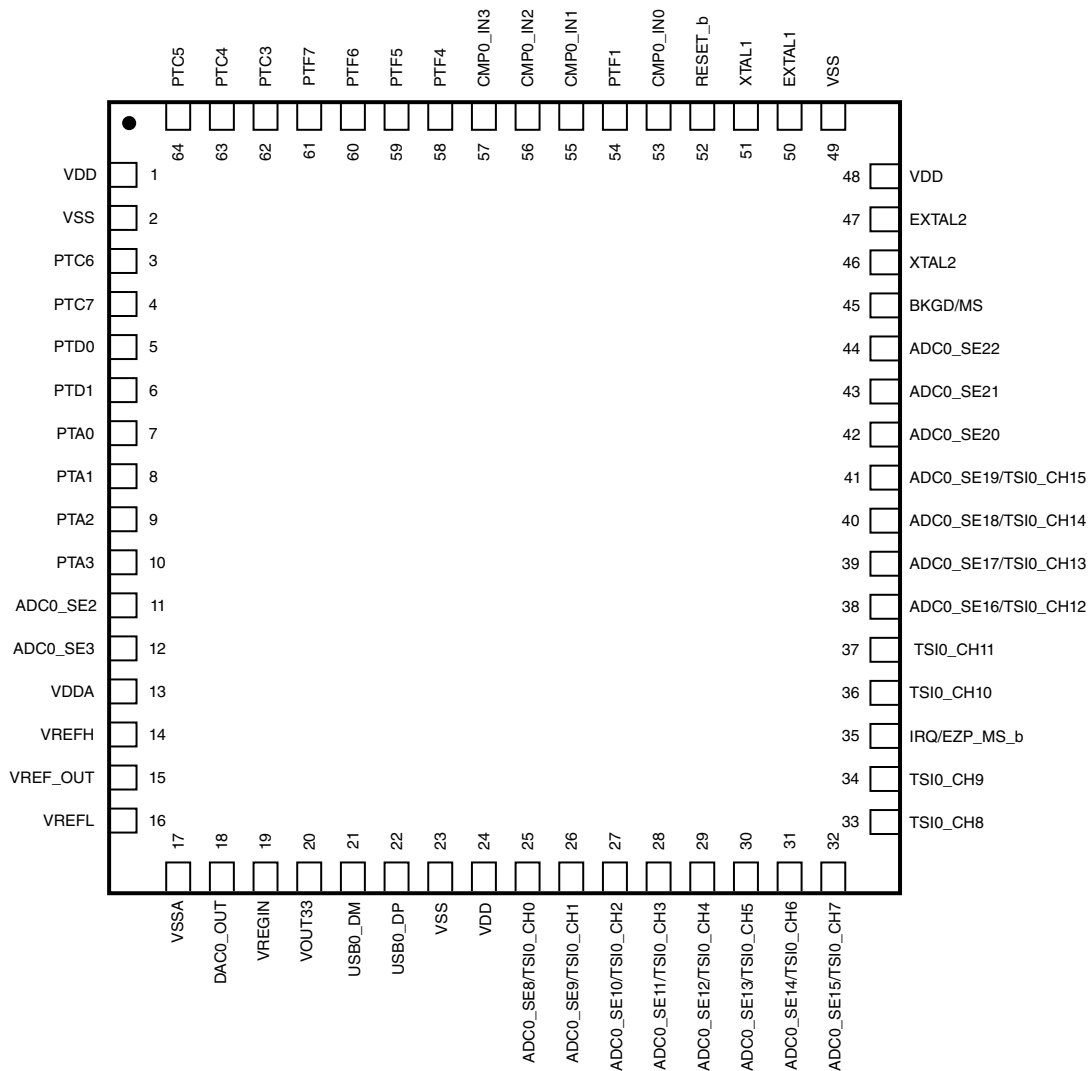

Figure 20. 64-pin LQFP

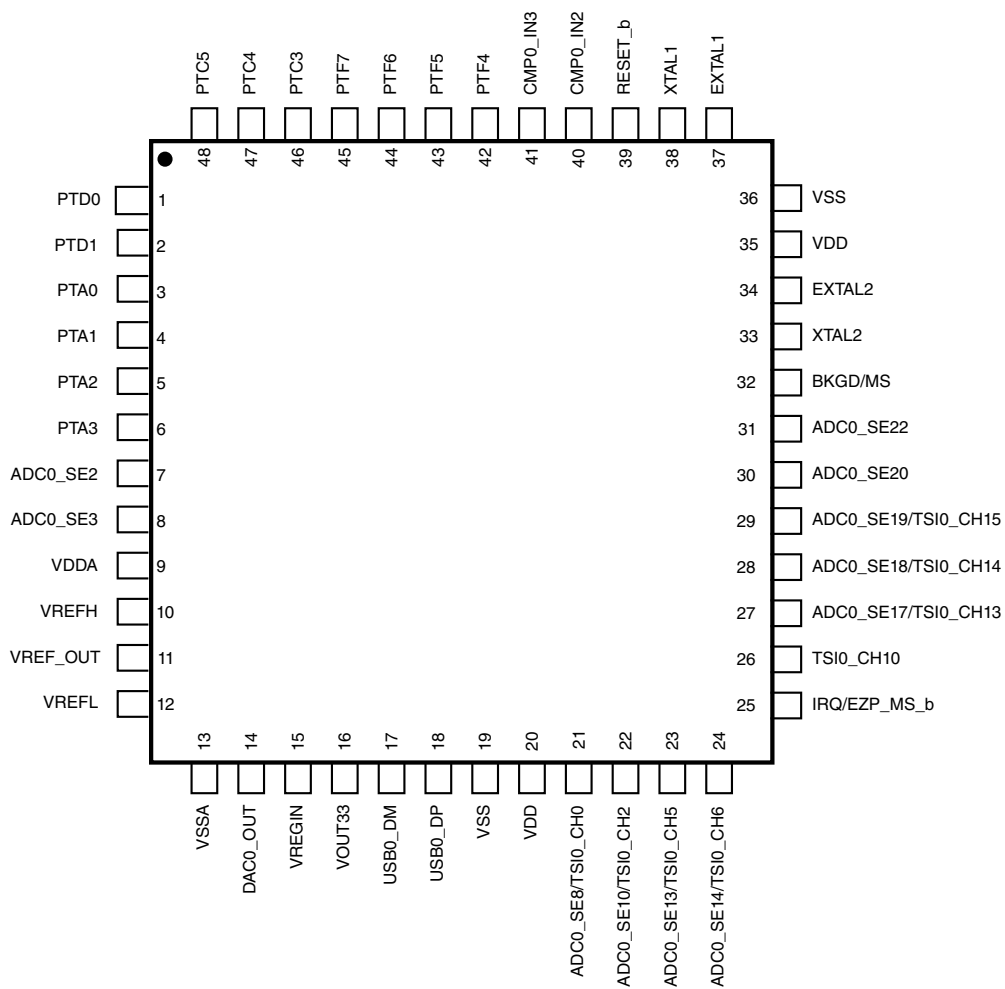
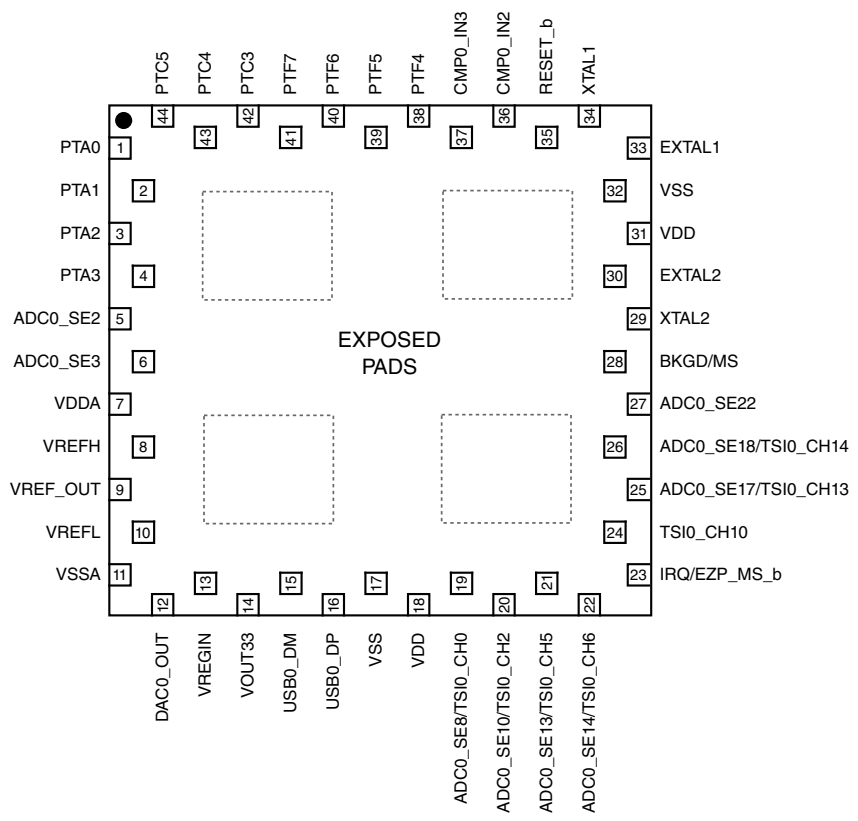

Figure 21. 48-pin LQFP



**Figure 22. 44-pin Laminated QFN**

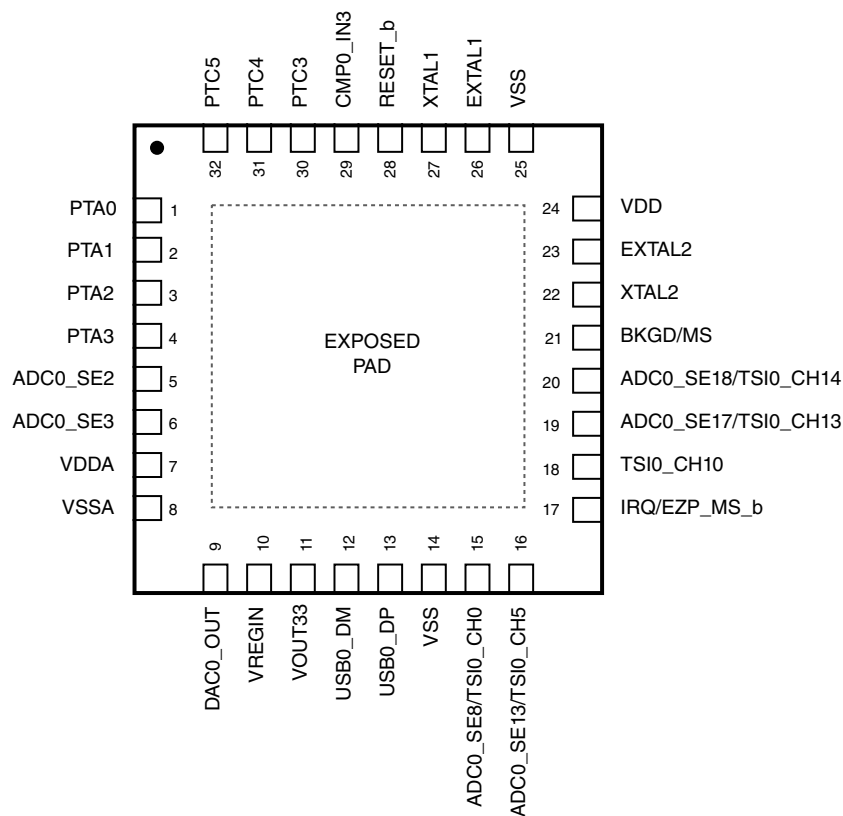

Figure 23. 32-pin QFN

### 8.3 Module-by-module signals

#### NOTE

- On PTB0, EZP\_MS\_b is active only during reset. Refer to the detailed boot description.
- PTC1 is open drain.

**Table 38. Module signals by GPIO port and pin**

64-pin	48-pin	44-pin	32-pin	Port	Module signal(s)
Power and ground					
1					VDD
24	20	18			VDD

Table continues on the next page...

**Table 38. Module signals by GPIO port and pin (continued)**

64-pin	48-pin	44-pin	32-pin	Port	Module signal(s)
48	35	31	24		VDD
2					VSS
23	19	17	14		VSS
49	36	32	25		VSS
System					
45	32	28	21	PTB4	BKGD/MS
12	8	6	6	PTA5	CLKOUT
62	46	42	30	PTC3	CLKOUT
10	6	4	4	PTA3	EZP_CLK
11	7	5	5	PTA4	EZP_DI
12	8	6	6	PTA5	EZP_DO
35	25	23	17	PTB0	IRQ/EZP_MS_b, EZP_CS_b
52	39	35	28	PTC1	RESET_b
OSC					
50	37	33	26	PTB7	EXTAL1
47	34	30	23	PTB6	EXTAL2
51	38	34	27	PTC0	XTAL1
46	33	29	22	PTB5	XTAL2
LLWU					
4				PTC7	LLWU_P0
6	2			PTD1	LLWU_P1
12	8	6	6	PTA5	LLWU_P2
30	23	21	16	PTA7	LLWU_P3
32				PTD7	LLWU_P4
35	25	23	17	PTB0	LLWU_P5
36	26	24	18	PTB1	LLWU_P6
39	27	25	19	PTB2	LLWU_P7
44	31	27		PTE7	LLWU_P8
45	32	28	21	PTB4	LLWU_P9
55				PTF2	LLWU_P10
56	40	36		PTF3	LLWU_P11
57	41	37	29	PTC2	LLWU_P12
59	43	39		PTF5	LLWU_P13
62	46	42	30	PTC3	LLWU_P14
63	47	43	31	PTC4	LLWU_P15
RGPIO					
51	38	34	27	PTC0	RGPIO0
56	40	36		PTF3	RGPIO1
57	41	37	29	PTC2	RGPIO2

Table continues on the next page...

**Table 38. Module signals by GPIO port and pin (continued)**

64-pin	48-pin	44-pin	32-pin	Port	Module signal(s)
62	46	42	30	PTC3	RGPIO3
63	47	43	31	PTC4	RGPIO4
64	48	44	32	PTC5	RGPIO5
3				PTC6	RGPIO6
4				PTC7	RGPIO7
5	1			PTD0	RGPIO8
6	2			PTD1	RGPIO9
26				PTD2	RGPIO10
27	22	20		PTD3	RGPIO11
28				PTD4	RGPIO12
29				PTD5	RGPIO13
31	24	22		PTD6	RGPIO14
32				PTD7	RGPIO15
LPTMR					
25	21	19	15	PTA6	LPTMR_ALT1
36	26	24	18	PTB1	LPTMR_ALT2
41	29			PTE4	LPTMR_ALT3
LPTMR-TOD					
50	37	33	26	PTB7	EXTAL1
47	34	30	23	PTB6	EXTAL2
25	21	19	15	PTA6	LPTMR_ALT1
36	26	24	18	PTB1	LPTMR_ALT2
41	29			PTE4	LPTMR_ALT3
51	38	34	27	PTC0	XTAL1
46	33	29	22	PTB5	XTAL2
PTA					
7	3	1	1	PTA0	PTA0
8	4	2	2	PTA1	PTA1
9	5	3	3	PTA2	PTA2
10	6	4	4	PTA3	PTA3
11	7	5	5	PTA4	PTA4
12	8	6	6	PTA5	PTA5
25	21	19	15	PTA6	PTA6
30	23	21	16	PTA7	PTA7
PTB					
35	25	23	17	PTB0	PTB0
36	26	24	18	PTB1	PTB1
39	27	25	19	PTB2	PTB2
40	28	26	20	PTB3	PTB3

Table continues on the next page...

**Table 38. Module signals by GPIO port and pin (continued)**

64-pin	48-pin	44-pin	32-pin	Port	Module signal(s)
45	32	28	21	PTB4	PTB4
46	33	29	22	PTB5	PTB5
47	34	30	23	PTB6	PTB6
50	37	33	26	PTB7	PTB7
PTC					
51	38	34	27	PTC0	PTC0
52	39	35	28	PTC1	PTC1
57	41	37	29	PTC2	PTC2
62	46	42	30	PTC3	PTC3
63	47	43	31	PTC4	PTC4
64	48	44	32	PTC5	PTC5
3				PTC6	PTC6
4				PTC7	PTC7
PTD					
5	1			PTD0	PTD0
6	2			PTD1	PTD1
26				PTD2	PTD2
27	22	20		PTD3	PTD3
28				PTD4	PTD4
29				PTD5	PTD5
31	24	22		PTD6	PTD6
32				PTD7	PTD7
PTE					
33				PTE0	PTE0
34				PTE1	PTE1
38				PTE3	PTE2
39	27	25	19	PTB2	PTE3
41	29			PTE4	PTE4
42	30			PTE5	PTE5
43				PTE6	PTE6
44	31	27		PTE7	PTE7
PTF					
53				PTF0	PTF0
54				PTF1	PTF1
55				PTF2	PTF2
56	40	36		PTF3	PTF3
58	42	38		PTF4	PTF4
59	43	39		PTF5	PTF5
60	44	40		PTF6	PTF6

Table continues on the next page...

**Table 38. Module signals by GPIO port and pin (continued)**

64-pin	48-pin	44-pin	32-pin	Port	Module signal(s)
61	45	41		PTF7	PTF7
5 V VREG					
20	16	14	11		VOUT33
19	15	13	10		VREGIN
USB0					
63	47	43	31	PTC4	USB_SOF_PULSE
62	46	42	30	PTC3	USB_CLKIN
21	17	15	12		USB0_DM
22	18	16	13		USB0_DP
20	16	14	11		VOUT33
19	15	13	10		VREGIN
ADC0					
11	7	5	5	PTA4	ADC0_SE2
12	8	6	6	PTA5	ADC0_SE3
25	21	19	15	PTA6	ADC0_SE8
26				PTD2	ADC0_SE9
27	22	20		PTD3	ADC0_SE10
28				PTD4	ADC0_SE11
29				PTD5	ADC0_SE12
30	23	21	16	PTA7	ADC0_SE13
31	24	22		PTD6	ADC0_SE14
32				PTD7	ADC0_SE15
38				PTE3	ADC0_SE16
39	27	25	19	PTB2	ADC0_SE17
40	28	26	20	PTB3	ADC0_SE18
41	29			PTE4	ADC0_SE19
42	30			PTE5	ADC0_SE20
43				PTE6	ADC0_SE21
44	31	27		PTE7	ADC0_SE22
13	9	7	7		VDDA
14	10	8			VREFH
16	12	10			VREFL
17	13	11	8		VSSA
DAC0					
18	14	12	9		DAC0_OUT
VREF					
15	11	9			VREF_OUT
CMP0					
53				PTF0	CMP0_IN0

Table continues on the next page...

**Table 38. Module signals by GPIO port and pin (continued)**

64-pin	48-pin	44-pin	32-pin	Port	Module signal(s)
55				PTF2	CMP0_IN1
56	40	36		PTF3	CMP0_IN2
57	41	37	29	PTC2	CMP0_IN3
54				PTF1	CMP0_OUT
CMT					
64	48	44	32	PTC5	CMT_IRO
I2S0					
5	1			PTD0	I2S0_MCLK/ I2S0_CLKIN
62	46	42	30	PTC3	I2S0_MCLK/ I2S0_CLKIN
6	2			PTD1	I2S0_RX_BCLK
61	45	41		PTF7	I2S0_RX_BCLK
7	3	1	1	PTA0	I2S0_RX_FS
60	44	40		PTF6	I2S0_RX_FS
8	4	2	2	PTA1	I2S0_RXD
59	43	39		PTF5	I2S0_RXD
10	6	4	4	PTA3	I2S0_TX_BCLK
58	42	38		PTF4	I2S0_TX_BCLK
11	7	5	5	PTA4	I2S0_TX_FS
57	41	37	29	PTC2	I2S0_TX_FS
12	8	6	6	PTA5	I2S0_TXD
56	40	36		PTF3	I2S0_TXD
TSI0					
25	21	19	15	PTA6	TSI0_CH0
26				PTD2	TSI0_CH1
27	22	20		PTD3	TSI0_CH2
28				PTD4	TSI0_CH3
29				PTD5	TSI0_CH4
30	23	21	16	PTA7	TSI0_CH5
31	24	22		PTD6	TSI0_CH6
32				PTD7	TSI0_CH7
33				PTE0	TSI0_CH8
34				PTE1	TSI0_CH9
36	26	24	18	PTB1	TSI0_CH10
37				PTE2	TSI0_CH11
38				PTE3	TSI0_CH12
39	27	25	19	PTB2	TSI0_CH13
40	28	26	20	PTB3	TSI0_CH14
41	29			PTE4	TSI0_CH15

Table continues on the next page...

**Table 38. Module signals by GPIO port and pin (continued)**

64-pin	48-pin	44-pin	32-pin	Port	Module signal(s)
PDB0					
44	31	27		PTE7	PDB0_EXTRG
63	47	43	31	PTC4	PDB0_EXTRG
FTM0					
34				PTE1	FTM_FLT0
25	21	19	15	PTA6	FTM_FLT1
36	26	24	18	PTB1	FTM_FLT2 / FTM0_QD_PHB
26				PTD2	FTM0_CH0/ FTM0_QD_PHA
27	22	20		PTD3	FTM0_CH1 / FTM0_QD_PHB
30	23	21	16	PTA7	FTM0_QD_PHA
51	38	34	27	PTC0	TMR_CLKIN0
50	37	33	26	PTB7	TMR_CLKIN1
FTM1					
34				PTE1	FTM_FLT0
25	21	19	15	PTA6	FTM_FLT1
36	26	24	18	PTB1	FTM_FLT2
7	3	1	1	PTA0	FTM1_CH0
8	4	2	2	PTA1	FTM1_CH1
9	5	3	3	PTA2	FTM1_CH2
10	6	4	4	PTA3	FTM1_CH3
11	7	5	5	PTA4	FTM1_CH4
12	8	6	6	PTA5	FTM1_CH5
51	38	34	27	PTC0	TMR_CLKIN0
50	37	33	26	PTB7	TMR_CLKIN1
MTIM					
51	38	34	27	PTC0	TMR_CLKIN0
50	37	33	26	PTB7	TMR_CLKIN1
Mini-FlexBus					
36	26	24	18	PTB1	FB_CLKOUT
27	22	20		PTD3	FBa_AD0
41	29			PTE4	FBa_AD1
42	30			PTE5	FBa_AD2
43				PTE6	FBa_AD3
44	31	27		PTE7	FBa_AD4
53				PTF0	FBa_AD5
54				PTF1	FBa_AD6
55				PTF2	FBa_AD7

*Table continues on the next page...*

**Table 38. Module signals by GPIO port and pin (continued)**

64-pin	48-pin	44-pin	32-pin	Port	Module signal(s)
56	40	36		PTF3	FBa_AD8
60	44	40		PTF6	FBa_AD9
61	45	41		PTF7	FBa_AD10
3				PTC6	FBa_AD11
4				PTC7	FBa_AD12
5	1			PTD0	FBa_AD13
6	2			PTD1	FBa_AD14
7	3	1	1	PTA0	FBa_AD15
8	4	2	2	PTA1	FBa_AD16
25	21	19	15	PTA6	FBa_AD17
57	41	37	29	PTC2	FBa_AD18
58	42	38		PTF4	FBa_AD19
40	28	26	20	PTB3	FBa_ALE
39	27	25	19	PTB2	FBa_CS0_b
37				PTE2	FBa_D0
34				PTE1	FBa_D1
33				PTE0	FBa_D2
32				PTD7	FBa_D3
31	24	22		PTD6	FBa_D4
30	23	21	16	PTA7	FBa_D5
29				PTD5	FBa_D6
28				PTD4	FBa_D7
38				PTE3	FBa_OE_b
59	43	39		PTF5	FBa_RW_b
DATA_BUS					
8	4	2	2	PTA1	FBa_AD16
39	27	25	19	PTB2	FBa_CS0_b
61	45	41		PTF7	FBa_D0
60	44	40		PTF6	FBa_D1
59	43	39		PTF5	FBa_D2
58	42	38		PTF4	FBa_D3
31	24	22		PTD6	FBa_D4
30	23	21	16	PTA7	FBa_D5
27	22	20		PTD3	FBa_D6
25	21	19	15	PTA6	FBa_D7
44	31	27		PTE7	FBa_RW_b
I2C0 and I2C1					
3				PTC6	I2C0_SCL
35	25	23	17	PTB0	I2C0_SCL

Table continues on the next page...

**Table 38. Module signals by GPIO port and pin (continued)**

64-pin	48-pin	44-pin	32-pin	Port	Module signal(s)
4				PTC7	I2C0_SDA
36	26	24	18	PTB1	I2C0_SDA
6	2			PTD1	I2C1_SCL
42	30			PTE5	I2C1_SCL
51	38	34	27	PTC0	I2C1_SCL
5	1			PTD0	I2C1_SDA
43				PTE6	I2C1_SDA
50	37	33	26	PTB7	I2C1_SDA
I2C2 and I2C3					
7	3	1	1	PTA0	I2C2_SCL
11	7	5	5	PTA4	I2C2_SCL
8	4	2	2	PTA1	I2C2_SDA
12	8	6	6	PTA5	I2C2_SDA
32				PTD7	I2C3_SCL
37				PTE2	I2C3_SCL
33				PTE0	I2C3_SDA
38				PTE3	I2C3_SDA
SPI0					
39	27	25	19	PTB2	SPI0_MISO
55				PTF2	SPI0_MISO
63	47	43	31	PTC4	SPI0_MISO
38				PTE3	SPI0_MOSI
40	28	26	20	PTB3	SPI0_MOSI
56	40	36		PTF3	SPI0_MOSI
64	48	44	32	PTC5	SPI0_MOSI
36	26	24	18	PTB1	SPI0_SCLK
54				PTF1	SPI0_SCLK
62	46	42	30	PTC3	SPI0_SCLK
7	3	1	1	PTA0	SPI0_SS
34				PTE1	SPI0_SS
53				PTF0	SPI0_SS
61	45	41		PTF7	SPI0_SS
SPI1					
4				PTC7	SPI1_MISO
11	7	5	5	PTA4	SPI1_MISO
43				PTE6	SPI1_MISO
59	43	39		PTF5	SPI1_MISO
3				PTC6	SPI1_MOSI
12	8	6	6	PTA5	SPI1_MOSI

Table continues on the next page...

**Table 38. Module signals by GPIO port and pin (continued)**

64-pin	48-pin	44-pin	32-pin	Port	Module signal(s)
44	31	27		PTE7	SPI1_MOSI
60	44	40		PTF6	SPI1_MOSI
5	1			PTD0	SPI1_SCLK
10	6	4	4	PTA3	SPI1_SCLK
42	30			PTE5	SPI1_SCLK
58	42	38		PTF4	SPI1_SCLK
6	2			PTD1	SPI1_SS
9	5	3	3	PTA2	SPI1_SS
41	29			PTE4	SPI1_SS
57	41	37	29	PTC2	SPI1_SS
UART0					
5	1			PTD0	UART0_CTS_b
32				PTD7	UART0_CTS_b
42	30			PTE5	UART0_CTS_b
62	46	42	30	PTC3	UART0_CTS_b
6	2			PTD1	UART0_RTS_b
33				PTE0	UART0_RTS_b
41	29			PTE4	UART0_RTS_b
61	45	41		PTF7	UART0_RTS_b
4				PTC7	UART0_RX
31	24	22		PTD6	UART0_RX
43				PTE6	UART0_RX
63	47	43	31	PTC4	UART0_RX
3				PTC6	UART0_TX
30	23	21	16	PTA7	UART0_TX
44	31	27		PTE7	UART0_TX
64	48	44	32	PTC5	UART0_TX
UART1					
11	7	5	5	PTA4	UART1_CTS_b
58	42	38		PTF4	UART1_CTS_b
12	8	6	6	PTA5	UART1_RTS_b
57	41	37	29	PTC2	UART1_RTS_b
10	6	4	4	PTA3	UART1_RX
59	43	39		PTF5	UART1_RX
9	5	3	3	PTA2	UART1_TX
60	44	40		PTF6	UART1_TX

## 9 Revision History

The following table summarizes content changes since the previous release of this document.

**Table 39. Revision History**

Rev. No.	Date	Substantial Changes
7	03/2015	<ul style="list-style-type: none"> <li>• Updated the value and description in Power mode transition operating behaviors</li> <li>• Updated the maximum value of <math>f_{\text{fil\_ref}}</math> in MCG specs</li> <li>• 12-bit ADC characteristics: Updated the values of temperature sensor slope for -40°C to 25°C and 25°C to 105°C</li> <li>• Updated the minimum and typical values of <math>V_{\text{out}}</math> in VREF full-range operating behaviors</li> <li>• Updated the maximum internal reference frequency and maximum FLL reference frequency range in MCG specifications</li> <li>• Updated the values of Temperature sensor voltage in 12-bit ADC characteristics</li> <li>• Removed the temperature parameter from VREF full-range operating requirements table</li> <li>• Removed Write endurance to FlexRAM for EEPROM section</li> <li>• Removed ADC calculator tool footnote from ADC operating conditions</li> </ul>



**How to Reach Us:**

**Home Page:**

[freescale.com](http://freescale.com)

**Web Support:**

[freescale.com/support](http://freescale.com/support)

Information in this document is provided solely to enable system and software implementers to use Freescale products. There are no express or implied copyright licenses granted hereunder to design or fabricate any integrated circuits based on the information in this document. Freescale reserves the right to make changes without further notice to any products herein.

Freescale makes no warranty, representation, or guarantee regarding the suitability of its products for any particular purpose, nor does Freescale assume any liability arising out of the application or use of any product or circuit, and specifically disclaims any and all liability, including without limitation consequential or incidental damages. "Typical" parameters that may be provided in Freescale data sheets and/or specifications can and do vary in different applications, and actual performance may vary over time. All operating parameters, including "typicals," must be validated for each customer application by customer's technical experts. Freescale does not convey any license under its patent rights nor the rights of others. Freescale sells products pursuant to standard terms and conditions of sale, which can be found at the following address: [freescale.com/SalesTermsandConditions](http://freescale.com/SalesTermsandConditions).

Freescale, the Freescale logo, and ColdFire+ are trademarks of Freescale Semiconductor, Inc., Reg. U.S. Pat. & Tm. Off. All other product or service names are the property of their respective owners. All rights reserved.

© 2010–2015 Freescale Semiconductor, Inc.

## Looking for pricing, stock, or lifecycle information?

Click below to explore more details on WIN SOURCE:

 [View MCF51JF64VLF on WIN SOURCE](#)

 [NXP / Nexperia Information](#)

## Optimize Your Supply Chain with WIN SOURCE Solutions

-  Global Sourcing Solution
-  Obsolete Management
-  Cost Control Management
-  Shortage Management
-  Alternative Solution
-  Excess Inventory Management