



**THE DATASHEET OF
MC56F82746VLF**



MC56F827XXDS

MC56F827xx

Supports MC56F82748VLH,
MC56F82748MLH, MC56F82746VLF,
MC56F82746MLF, MC56F82743VLC,
MC56F82743VFM, MC56F82738VLH,
MC56F82736VLF, MC56F82733VLC,
MC56F82733VFM, MC56F82733MFM,
MC56F82728VLH, MC56F82726VLF,
MC56F82723VLC, MC56F82723VFM

Features

- This family of digital signal controllers (DSCs) is based on the 32-bit 56800EX core. On a single chip, each device combines the processing power of a DSP and the functionality of an MCU, with a flexible set of peripherals to support many target applications:
 - Industrial control
 - Home appliances
 - Smart sensors
 - Wireless charging
 - Switched-mode power supply and power management
 - Power distribution systems
 - Motor control (ACIM, BLDC, PMSM, SR, stepper)
 - Photovoltaic systems
 - Circuit breaker
 - Medical device/equipment
 - Instrumentation
 - Uninterruptible power supplies (UPS)
 - Lighting
- DSC based on 32-bit 56800EX core
 - Up to 100 MIPS at 100 MHz core frequency in fast mode
 - DSP and MCU functionality in a unified, C-efficient architecture
- On-chip memory
 - Up to 64 KB flash memory
 - Up to 8 KB data/program RAM
 - On-chip flash memory and RAM can be mapped into both program and data memory spaces
- Analog
 - Two high-speed, 8-channel, 12-bit ADCs with dynamic x1, x2, and x4 programmable amplifier
 - Four analog comparators with integrated 6-bit DAC references
 - Up to two 12-bit digital-to-analog converters (DAC)
- One eFlexPWM module with up to 8 PWM outputs, including 8 channels with high resolution NanoEdge placement
- Communication interfaces
 - Up to two high-speed queued SCI (QSCI) modules with LIN slave functionality
 - Up to two queued SPI (QSPI) modules
 - One I2C/SMBus port
 - One Modular/Scalable Controller Area Network (MSCAN) module
- Timers
 - One 16-bit quad timer (1 x 4 16-bit timer)
 - Two Periodic Interval Timers (PITs)
- Security and integrity
 - Cyclic Redundancy Check (CRC) generator
 - Windowed Computer operating properly (COP) watchdog
 - External Watchdog Monitor (EWM)
- Clocks
 - Two on-chip relaxation oscillators: 8 MHz (400 kHz at standby mode) and 200 kHz
 - Crystal / resonator oscillator

- System
 - DMA controller
 - Integrated power-on reset (POR) and low-voltage interrupt (LVI) and brown-out reset module
 - Inter-module crossbar connection
 - JTAG/enhanced on-chip emulation (EOnCE) for unobtrusive, real-time debugging
- Operating characteristics
 - Single supply: 3.0 V to 3.6 V
 - 5 V-tolerant I/O (except for RESETB pin which is a 3.3 V pin only)
 - Operation ambient temperature: V temperature option: -40°C to 105°C
 - Operation ambient temperature: M temperature option: -40°C to 125°C
- 64-pin LQFP, 48-pin LQFP, 32-pin QFN, and 32-pin LQFP packages

Table of Contents

1	Overview.....	4	6.1	Thermal handling ratings.....	31
1.1	MC56F827xx Product Family.....	4	6.2	Moisture handling ratings.....	31
1.2	56800EX 32-bit Digital Signal Controller (DSC) core.....	5	6.3	ESD handling ratings.....	31
1.3	Operation Parameters.....	6	6.4	Voltage and current operating ratings.....	32
1.4	On-Chip Memory and Memory Protection.....	6	7	General.....	34
1.5	Interrupt Controller.....	7	7.1	General characteristics.....	34
1.6	Peripheral highlights.....	7	7.2	AC electrical characteristics.....	34
1.7	Block diagrams.....	13	7.3	Nonswitching electrical specifications.....	35
2	MC56F827xx signal and pin descriptions.....	16	7.4	Switching specifications.....	42
2.1	Signal groups.....	25	7.5	Thermal specifications.....	43
3	Ordering parts.....	25	8	Peripheral operating requirements and behaviors.....	44
3.1	Determining valid orderable parts.....	25	8.1	Core modules.....	44
4	Part identification.....	26	8.2	System modules.....	45
4.1	Description.....	26	8.3	Clock modules.....	46
4.2	Format.....	26	8.4	Memories and memory interfaces.....	48
4.3	Fields.....	26	8.5	Analog.....	50
4.4	Example.....	27	8.6	PWMs and timers.....	56
5	Terminology and guidelines.....	27	8.7	Communication interfaces.....	57
5.1	Definition: Operating requirement.....	27	9	Design Considerations.....	63
5.2	Definition: Operating behavior.....	27	9.1	Thermal design considerations.....	63
5.3	Definition: Attribute.....	28	9.2	Electrical design considerations.....	65
5.4	Definition: Rating.....	28	9.3	Power-on Reset design considerations.....	66
5.5	Result of exceeding a rating.....	28	10	Obtaining package dimensions.....	68
5.6	Relationship between ratings and operating requirements.....	29	11	Pinout.....	68
5.7	Guidelines for ratings and operating requirements.....	29	11.1	Signal Multiplexing and Pin Assignments.....	68
5.8	Definition: Typical value.....	30	11.2	Pinout diagrams.....	71
5.9	Typical value conditions.....	31	12	Product documentation.....	73
6	Ratings.....	31	13	Revision History.....	74

1 Overview

1.1 MC56F827xx Product Family

The following table is the comparison of features among members of the family.

Table 1. MC56F827xx Family

Feature	MC56F82											
	748V LH	746V LF	743V LC	743V FM	738V LH	736V LF	733V LC	733V FM	728V LH	726V LF	723V LC	723V FM
	748M LH	746M LF						733M FM				
Core frequency (MHz)	100/50	100/50	100/50	100/50	100/50	100/50	100/50	100/50	100/50	100/50	100/50	100/50
Flash memory (KB)	64	64	64	64	48	48	48	48	32	32	32	32
RAM (KB)	8	8	8	8	8	8	8	8	6	6	6	6
Interrupt Controller	Yes	Yes	Yes	Yes	Yes	Yes	Yes	Yes	Yes	Yes	Yes	Yes
Windowed Computer Operating Properly (WCOP)	1	1	1	1	1	1	1	1	1	1	1	1
External Watchdog Monitor (EWM)	1	1	1	1	1	1	1	1	1	1	1	1
Periodic Interrupt Timer (PIT)	2	2	2	2	2	2	2	2	2	2	2	2
Cyclic Redundancy Check (CRC)	1	1	1	1	1	1	1	1	1	1	1	1
Quad Timer (TMR)	1x4	1x4	1x4	1x4	1x4	1x4	1x4	1x4	1x4	1x4	1x4	1x4
12-bit Cyclic ADC channels	2x8	2x5	2x3	2x3	2x8	2x5	2x3	2x3	2x8	2x5	2x3	2x3
PWM Module:												
Input capture channels ²	12	6	6	6	12	6	6	6	12	6	6	6
High-resolution channels	8	6	6	6	8	6	6	6	8	6	6	6
Standard channels	4	0	0	0	4	0	0	0	4	0	0	0
12-bit DAC	2	2	2	2	2	2	2	2	2	2	2	2
DMA	Yes	Yes	Yes	Yes	Yes	Yes	Yes	Yes	Yes	Yes	Yes	Yes

Table continues on the next page...

Table 1. MC56F827xx Family (continued)

Feature	MC56F82											
	748V LH	746V LF	743V LC	743V FM	738V LH	736V LF	733V LC	733V FM	728V LH	726V LF	723V LC	723V FM
	748M LH	746M LF						733M FM				
Analog Comparators (CMP)	4	4	3	3	4	4	3	3	4	4	3	3
QSCI	2	2	1	1	2	2	1	1	2	2	1	1
QSPI	2	1	1	1	2	1	1	1	2	1	1	1
I2C/SMBus	1	1	1	1	1	1	1	1	1	1	1	1
MSCAN	1	1	0	0	1	1	0	0	1	1	0	0
GPIO	54	39	26	26	54	39	26	26	54	39	26	26
Package pin count	64 LQFP	48 LQFP	32 LQFP	32 QFN	64 LQFP	48 LQFP	32 LQFP	32 QFN	64 LQFP	48 LQFP	32 LQFP	32 QFN
AEC-Q100 ³	Yes	Yes	No	No	Yes	Yes	No	No	Yes	Yes	No	No

- Temperature options
V: -40°C to 105°C
M: -40°C to 125°C
- Input capture shares the pin with coresponding PWM channels.
- Qualification aligned to AEC-Q100

1.2 56800EX 32-bit Digital Signal Controller (DSC) core

- Efficient 32-bit 56800EX Digital Signal Processor (DSP) engine with modified dual Harvard architecture:
 - Three internal address buses
 - Four internal data buses: two 32-bit primary buses, one 16-bit secondary data bus, and one 16-bit instruction bus
 - 32-bit data accesses
 - Supports concurrent instruction fetches in the same cycle, and dual data accesses in the same cycle
 - 20 addressing modes
- As many as 100 million instructions per second (MIPS) at 100 MHz core frequency
- 162 basic instructions
- Instruction set supports both fractional arithmetic and integer arithmetic
- 32-bit internal primary data buses support 8-bit, 16-bit, and 32-bit data movement, plus addition, subtraction, and logical operations
- Single-cycle 16 × 16-bit → 32-bit and 32 × 32-bit → 64-bit multiplier-accumulator (MAC) with dual parallel moves
- 32-bit arithmetic and logic multi-bit shifter
- Four 36-bit accumulators, including extension bits

- Parallel instruction set with unique DSP addressing modes
- Hardware DO and REP loops
- Bit reverse address mode, which effectively supports DSP and Fast Fourier Transform algorithms
- Full shadowing of the register stack for zero-overhead context saves and restores: nine shadow registers correspond to nine address registers (R0, R1, R2, R3, R4, R5, N, N3, M01)
- Instruction set supports both DSP and controller functions
- Controller-style addressing modes and instructions enable compact code
- Enhanced bit manipulation instruction set
- Efficient C compiler and local variable support
- Software subroutine and interrupt stack, with the stack's depth limited only by memory
- Priority level setting for interrupt levels
- JTAG/Enhanced On-Chip Emulation (OnCE) for unobtrusive, real-time debugging that is independent of processor speed

1.3 Operation Parameters

- Up to 50 MHz operation in normal mode and 100 MHz operation in fast mode
- Operation ambient temperature:
 - V Temperature option: -40 °C to 105°C
 - M Temperature option: -40 °C to 125°C
- Single 3.3 V power supply
- Supply range: $V_{DD} - V_{SS} = 2.7 \text{ V to } 3.6 \text{ V}$, $V_{DDA} - V_{SSA} = 2.7 \text{ V to } 3.6 \text{ V}$

1.4 On-Chip Memory and Memory Protection

- Dual Harvard architecture permits as many as three simultaneous accesses to program and data memory
- Internal flash memory with security and protection to prevent unauthorized access
- Memory resource protection (MRP) unit to protect supervisor programs and resources from user programs
- Programming code can reside in flash memory during flash programming
- The dual-port RAM controller supports concurrent instruction fetches and data accesses, or dual data accesses by the core.
 - Concurrent accesses provide increased performance.
 - The data and instruction arrive at the core in the same cycle, reducing latency.
- On-chip memory

- Up to 64 KB program/data flash memory
- Up to 8 KB dual port data/program RAM

1.5 Interrupt Controller

- Five interrupt priority levels
 - Three user-programmable priority levels for each interrupt source: level 0, level 1, level 2
 - Unmaskable level 3 interrupts include illegal instruction, hardware stack overflow, misaligned data access, SWI3 instruction
 - Interrupt level 3 is highest priority and non-maskable. Its sources include:
 - Illegal instructions
 - Hardware stack overflow
 - SWI instruction
 - EOnce interrupts
 - Misaligned data accesses
 - Lowest-priority software interrupt: level LP
- Support for nested interrupts, so that a higher priority level interrupt request can interrupt lower priority interrupt subroutine
- Masking of interrupt priority level is managed by the 56800EX core
- Two programmable fast interrupts that can be assigned to any interrupt source
- Notification to System Integration Module (SIM) to restart clock when in wait and stop states
- Ability to relocate interrupt vector table

1.6 Peripheral highlights

1.6.1 Enhanced Flex Pulse Width Modulator (eFlexPWM)

- 16 bits of resolution for center, edge-aligned, and asymmetrical PWMs
- PWM outputs can be configured as complementary output pairs or independent outputs
- Dedicated time-base counter with period and frequency control per submodule
- Independent top and bottom deadtime insertion for each complementary pair
- Independent control of both edges of each PWM output
- Enhanced input capture and output compare functionality on each input:
 - Channels not used for PWM generation can be used for buffered output compare functions.

- Channels not used for PWM generation can be used for input capture functions.
- Enhanced dual edge capture functionality
- Synchronization of submodule to external hardware (or other PWM) is supported.
- Double-buffered PWM registers
 - Integral reload rates from 1 to 16
 - Half-cycle reload capability
- Multiple output trigger events can be generated per PWM cycle via hardware.
- Support for double-switching PWM outputs
- Up to eight fault inputs can be assigned to control multiple PWM outputs
 - Programmable filters for fault inputs
- Independently programmable PWM output polarity
- Individual software control of each PWM output
- All outputs can be programmed to change simultaneously via a FORCE_OUT event.
- PWMX pin can optionally output a third PWM signal from each submodule
- Option to supply the source for each complementary PWM signal pair from any of the following:
 - Crossbar module outputs
 - External ADC input, taking into account values set in ADC high and low limit registers

1.6.2 12-bit Analog-to-Digital Converter (Cyclic type)

- Two independent 12-bit analog-to-digital converters (ADCs):
 - 2 x 8-channel external inputs
 - Built-in x1, x2, x4 programmable gain pre-amplifier
 - Maximum ADC clock frequency up to 10 MHz, having period as low as 100-ns
 - Single conversion time of 10 ADC clock cycles
 - Additional conversion time of 8 ADC clock cycles
- Support of analog inputs for single-ended and differential, including unipolar differential, conversions
- Sequential, parallel, and independent scan mode
- First 8 samples have offset, limit and zero-crossing calculation supported
- ADC conversions can be synchronized by *any* module connected to the internal crossbar module, such as PWM, timer, GPIO, and comparator modules.
- Support for simultaneous triggering and software-triggering conversions
- Support for a multi-triggering mode with a programmable number of conversions on each trigger
- Each ADC has ability to scan and store up to 8 conversion results.
- Current injection protection

1.6.3 Periodic Interrupt Timer (PIT) Modules

- 16-bit counter with programmable count modulo
- PIT0 is master and PIT1 is slave (if synchronizing both PITs)
- The output signals of both PIT0 and PIT1 are internally connected to a peripheral crossbar module
- Can run when the CPU is in Wait/Stop modes. Can also wake up the CPU from Wait/Stop modes.
- In addition to its existing bus clock (up to 50 MHz), 3 alternate clock sources for the counter clock are available:
 - Crystal oscillator output
 - 8 MHz / 400 kHz ROSC (relaxation oscillator output)
 - On-chip low-power 200 kHz oscillator

1.6.4 Inter-Module Crossbar and AND-OR-INVERT logic

- Provides generalized connections between and among on-chip peripherals: ADCs, 12-bit DAC, comparators, quad-timers, eFlexPWMs, EWM, and select I/O pins
- User-defined input/output pins for all modules connected to the crossbar
- DMA request and interrupt generation from the crossbar
- Write-once protection for all registers
- AND-OR-INVERT function provides a universal Boolean function generator that uses a four-term sum-of-products expression, with each product term containing true or complement values of the four selected inputs (A, B, C, D).

1.6.5 Comparator

- Full rail-to-rail comparison range
- Support for high and low speed modes
- Selectable input source includes external pins and internal DACs
- Programmable output polarity
- 6-bit programmable DAC as a voltage reference per comparator
- Three programmable hysteresis levels
- Selectable interrupt on rising-edge, falling-edge, or toggle of a comparator output

1.6.6 12-bit Digital-to-Analog Converter

- 12-bit resolution
- Powerdown mode

- Automatic mode allows the DAC to automatically generate pre-programmed output waveforms, including square, triangle, and sawtooth waveforms (for applications like slope compensation)
- Programmable period, update rate, and range
- Output can be routed to an internal comparator, ADC, or optionally to an off-chip destination

1.6.7 Quad Timer

- Four 16-bit up/down counters, with a programmable prescaler for each counter
- Operation modes: edge count, gated count, signed count, capture, compare, PWM, signal shot, single pulse, pulse string, cascaded, quadrature decode
- Programmable input filter
- Counting start can be synchronized across counters
- Up to 100 MHz operation clock

1.6.8 Queued Serial Communications Interface (QSCI) modules

- Operating clock can be up to two times the CPU operating frequency
- Four-word-deep FIFOs available on both transmit and receive buffers
- Standard mark/space non-return-to-zero (NRZ) format
- 16-bit integer and 3-bit fractional baud rate selection
- Full-duplex or single-wire operation
- Programmable 8-bit or 9-bit data format
- Error detection capability
- Two receiver wakeup methods:
 - Idle line
 - Address mark
- 1/16 bit-time noise detection
- Up to 6.25 Mbit/s baud rate at 100 MHz operation clock

1.6.9 Queued Serial Peripheral Interface (QSPI) modules

- Maximum 12.5 Mbit/s baud rate
- Selectable baud rate clock sources for low baud rate communication
- Baud rate as low as $\text{Baudrate_Freq_in} / 8192$
- Full-duplex operation
- Master and slave modes
- Double-buffered operation with separate transmit and receive registers
- Four-word-deep FIFOs available on transmit and receive buffers

- Programmable length transmissions (2 bits to 16 bits)
- Programmable transmit and receive shift order (MSB as first bit transmitted)

1.6.10 Inter-Integrated Circuit (I2C)/System Management Bus (SMBus) modules

- Compatible with I2C bus standard
- Support for System Management Bus (SMBus) specification, version 2
- Multi-master operation
- General call recognition
- 10-bit address extension
- Start/Repeat and Stop indication flags
- Support for dual slave addresses or configuration of a range of slave addresses
- Programmable glitch input filter with option to clock up to 100 MHz

1.6.11 Modular/Scalable Controller Area Network (MSCAN) Module

- Clock source from PLL or oscillator.
- Implementation of the CAN protocol Version 2.0 A/B
- Standard and extended data frames
- 0-to-8 bytes data length
- Programmable bit rate up to 1 Mbit/s
- Support for remote frames
- Individual Rx Mask Registers per Message Buffer
- Internal timer for time-stamping of received and transmitted messages
- Listen-only mode capability
- Programmable loopback mode supporting self-test operation
- Programmable transmission priority scheme: lowest ID, lowest buffer number, or highest priority
- Low power modes, with programmable wakeup on bus activity

1.6.12 Windowed Computer Operating Properly (COP) watchdog

- Programmable windowed timeout period
- Support for operation in all power modes: run mode, wait mode, stop mode
- Causes loss of reference reset 128 cycles after loss of reference clock to the PLL is detected
- Selectable reference clock source in support of EN60730 and IEC61508
- Selectable clock sources:
 - External crystal oscillator/external clock source

- On-chip low-power 200 kHz oscillator
- System bus (IPBus up to 50 MHz)
- 8 MHz / 400 kHz ROSC
- Support for interrupt triggered when the counter reaches the timeout value

1.6.13 External Watchdog Monitor (EWM)

- Monitors external circuit as well as the software flow
- Programmable timeout period
- Interrupt capability prior to timeout
- Independent output (EWM_OUT_b) that places external circuit (but not CPU and peripheral) in a safe mode when EWM timeout occurs
- Selectable reference clock source in support of EN60730 and IEC61508
- Wait mode and Stop mode operation is not supported.
- Selectable clock sources:
 - External crystal oscillator/external clock source
 - On-chip low-power 200 kHz oscillator
 - System bus (IPBus up to 50 MHz)
 - 8 MHz / 400 kHz ROSC

1.6.14 Power supervisor

- Power-on reset (POR) is released after $V_{DD} > 2.7$ V during supply is ramped up; CPU, peripherals, and JTAG/EOnCE controllers exit RESET state
- Brownout reset ($V_{DD} < 2.0$ V)
- Critical warn low-voltage interrupt (LVI 2.2 V)
- Peripheral low-voltage warning interrupt (LVI 2.7 V)

1.6.15 Phase-locked loop

- Wide programmable output frequency: 200 MHz to 400 MHz
- Input reference clock frequency: 8 MHz to 16 MHz
- Detection of loss of lock and loss of reference clock
- Ability to power down

1.6.16 Clock sources

1.6.16.1 On-chip oscillators

- Tunable 8 MHz relaxation oscillator with 400 kHz at standby mode (divide-by-two output)
- 200 kHz low frequency clock as secondary clock source for COP, EWM, PIT

1.6.16.2 Crystal oscillator

- Support for both high ESR crystal oscillator (ESR greater than 100 Ω) and ceramic resonator
- Operating frequency: 4–16 MHz

1.6.17 Cyclic Redundancy Check (CRC) Generator

- Hardware CRC generator circuit with 16-bit shift register
- High-speed hardware CRC calculation
- Programmable initial seed value
- CRC16-CCITT compliancy with $x^{16} + x^{12} + x^5 + 1$ polynomial
- Error detection for all single, double, odd, and most multibit errors
- Option to transpose input data or output data (CRC result) bitwise, which is required for certain CRC standards

1.6.18 General Purpose I/O (GPIO)

- 5 V tolerance (except RESETB pin)
- Individual control of peripheral mode or GPIO mode for each pin
- Programmable push-pull or open drain output
- Configurable pullup or pulldown on all input pins
- All pins (except JTAG and RESETB) default to be GPIO inputs
- 2 mA / 9 mA source/sink capability
- Controllable output slew rate

1.7 Block diagrams

The 56800EX core is based on a modified dual Harvard-style architecture, consisting of three execution units operating in parallel, and allowing as many as six operations per instruction cycle. The MCU-style programming model and optimized instruction set

enable straightforward generation of efficient and compact code for the DSP and control functions. The instruction set is also efficient for C compilers, to enable rapid development of optimized control applications.

The device's basic architecture appears in Figure 1 and Figure 2. Figure 1 shows how the 56800EX system buses communicate with internal memories, and the IPBus interface and the internal connections among the units of the 56800EX core. Figure 2 shows the peripherals and control blocks connected to the IPBus bridge. See the specific device's Reference Manual for details.

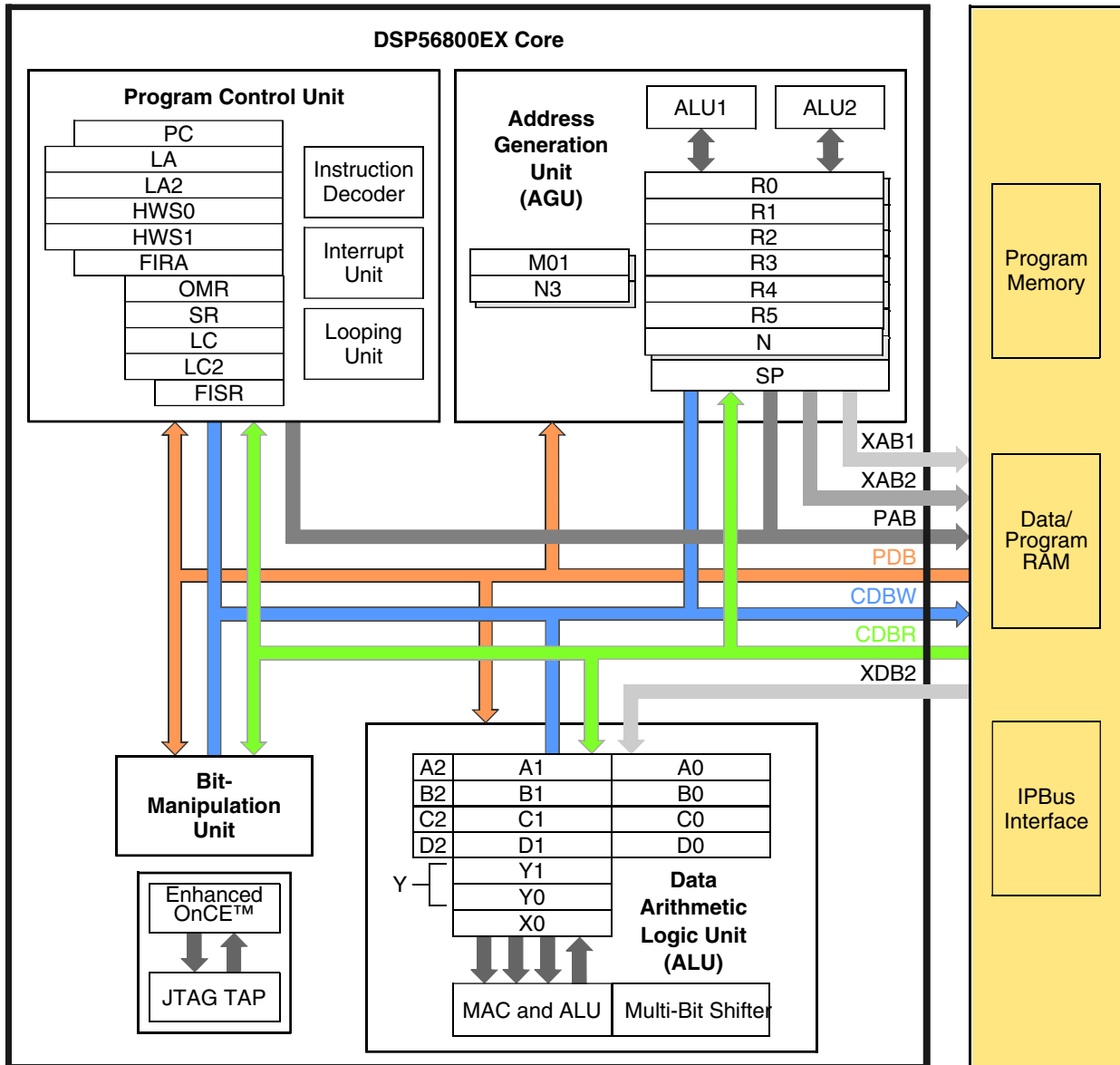

Figure 1. 56800EX basic block diagram

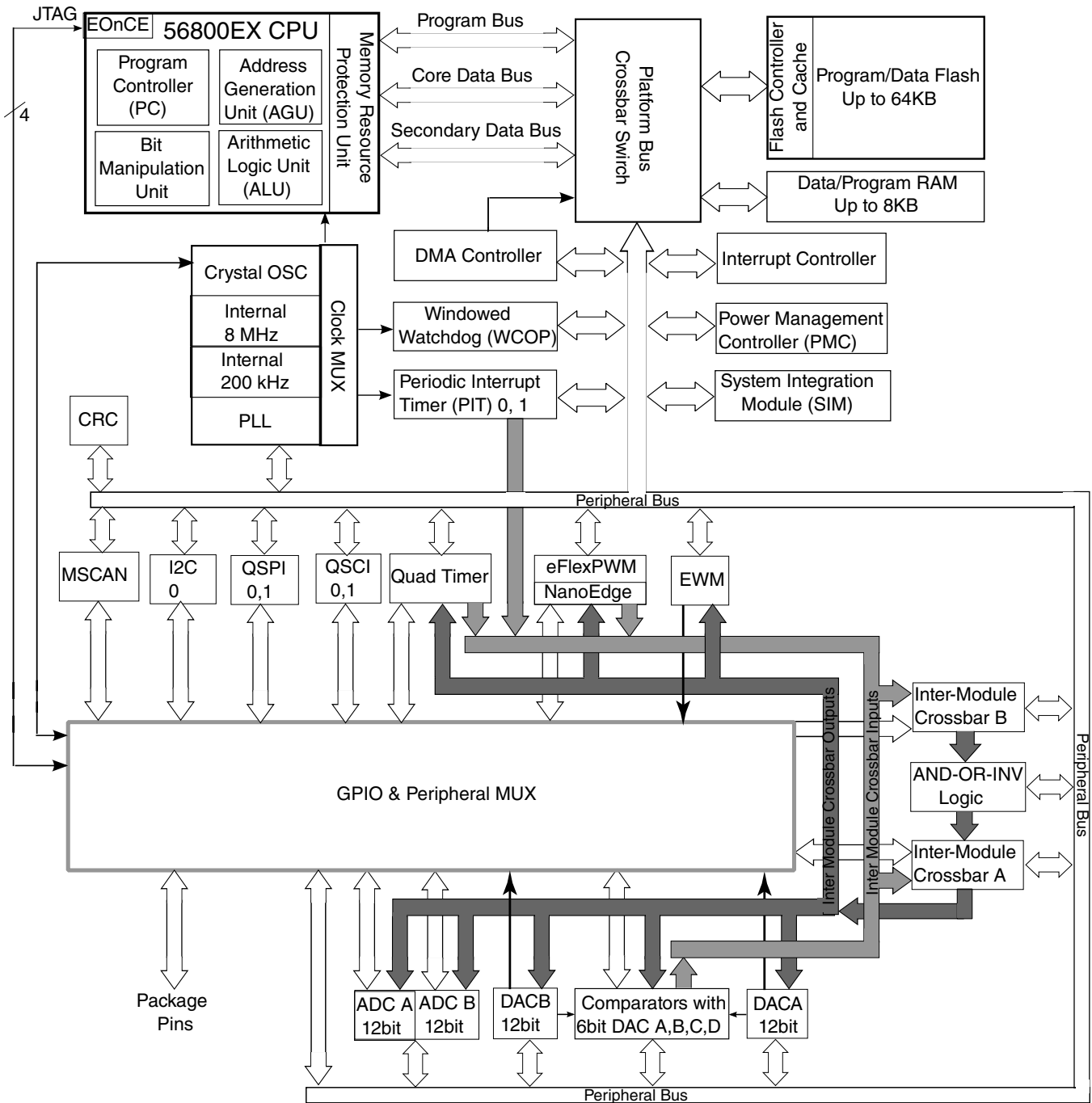

Figure 2. System diagram

2 MC56F827xx signal and pin descriptions

After reset, each pin is configured for its primary function (listed first). Any alternative functionality, shown in parentheses, must be programmed through the GPIO module peripheral enable registers (GPIOx_PER) and the SIM module GPIO peripheral select (GPSx) registers. All GPIO ports can be individually programmed as an input or output (using bit manipulation).

- PWMA_FAULT0, PWMA_FAULT1, and similar signals are inputs used to disable selected PWMA outputs, in cases where the fault conditions originate off-chip.

For the MC56F827xx products, which use 64-pin LQFP, 48-pin LQFP and 32-pin packages:

Table 2. Signal descriptions

Signal Name	64 LQFP	48 LQFP	32 LQFP	Type	State During Reset	Signal Description
V _{DD}	29	—	—	Supply	Supply	I/O Power — Supplies 3.3 V power to the chip I/O interface.
	44	32	—			
	60	44	28			
V _{SS}	30	22	14	Supply	Supply	I/O Ground — Provide ground for the device I/O interface.
	43	31	—			
	61	45	29			
V _{DDA}	22	15	9	Supply	Supply	Analog Power — Supplies 3.3 V power to the analog modules. It must be connected to a clean analog power supply.
V _{SSA}	23	16	10	Supply	Supply	Analog Ground — Supplies an analog ground to the analog modules. It must be connected to a clean power supply.
V _{CAP}	26	19	—	On-chip regulator output	On-chip regulator output	Connect a 2.2 μF bypass capacitor between this pin and V _{SS} to stabilize the core voltage regulator output required for proper device operation. NOTE: The total bypass capacitor value between all V _{CAP} pin and V _{SS} should not exceed 4.7 μF.
	57	43	27			
TDI	64	48	32	Input	Input, internal pullup enabled	Test Data Input — It is sampled on the rising edge of TCK and has an internal pullup resistor. After reset, the default state is TDI.
(GPIOD0)				Input/Output		GPIO Port D0
TDO	62	46	30	Output	Output	Test Data Output — It is driven in the shift-IR and shift-DR controller states, and it changes on the falling edge of TCK. After reset, the default state is TDO

Table continues on the next page...

Table 2. Signal descriptions (continued)

Signal Name	64 LQFP	48 LQFP	32 LQFP	Type	State During Reset	Signal Description
(GPIO D1)				Input/Output	Output	GPIO Port D1
TCK	1	1	1	Input	Input, internal pulldown enabled	Test Clock Input — The pin is connected internally to a pulldown resistor. A Schmitt-trigger input is used for noise immunity. After reset, the default state is TCK
(GPIO D2)				Input/Output		
TMS	63	47	31	Input	Input, internal pullup enabled	Test Mode Select Input — It is sampled on the rising edge of TCK and has an internal pullup resistor. After reset, the default state is TMS. NOTE: Always tie the TMS pin to V _{DD} through a 2.2 kΩ resistor if need to keep on-board debug capability. Otherwise, directly tie to V _{DD} .
(GPIO D3)				Input/Output		
RESET or RESETB	2	2	2	Input	Input, internal pullup enabled	Reset — A direct hardware reset on the processor. When RESET is asserted low, the device is initialized and placed in the reset state. A Schmitt-trigger input is used for noise immunity. The internal reset signal is deasserted synchronous with the internal clocks after a fixed number of internal clocks. After reset, the default state is RESET. Recommended a capacitor of up to 0.1 μF for filtering noise.
(GPIO D4)				Input/Opendedrain Output		
GPIOA0	13	9	6	Input/Output	Input	GPIO Port A0
(ANA0&CMPA_IN3)				Input		ANA0 is analog input to channel 0 of ADCA; CMPA_IN3 is positive input 3 of analog comparator A. After reset, the default state is GPIOA0.
(CMPC_O)				Output		Analog comparator C output
GPIOA1	14	10	7	Input/Output	Input	GPIO Port A1: After reset, the default state is GPIOA1.
(ANA1&CMPA_IN0)				Input		ANA1 is analog input to channel 1 of ADCA; CMPA_IN0 is negative input 0 of analog comparator A. When used as an analog input, the signal goes to ANA1 and CMPA_IN0. The ADC control register configures this input as ANA1 or CMPA_IN0.
GPIOA2	15	11	8	Input/Output	Input	GPIO Port A2: After reset, the default state is GPIOA2.

Table continues on the next page...

Table 2. Signal descriptions (continued)

Signal Name	64 LQFP	48 LQFP	32 LQFP	Type	State During Reset	Signal Description
(ANA2&VREFHA &CMPA_IN1)				Input		ANA2 is analog input to channel 2 of ADCA; VREFHA is analog reference high of ADCA; CMPA_IN1 is negative input 1 of analog comparator A. When used as an analog input, the signal goes to both ANA2, VREFHA, and CMPA_IN1.
GPIOA3	16	12	—	Input/Output	Input	GPIO Port A3: After reset, the default state is GPIOA3.
(ANA3&VREFLA& CMPA_IN2)				Input		ANA3 is analog input to channel 3 of ADCA; VREFLA is analog reference low of ADCA; CMPA_IN2 is negative input 2 of analog comparator A.
GPIOA4	12	8	—	Input/Output	Input	GPIO Port A4: After reset, the default state is GPIOA4.
(ANA4&CMPD_IN 0)				Input		ANA4 is Analog input to channel 4 of ADCA; CMPD_IN0 is input 0 to comparator D.
GPIOA5	11	—	—	Input/Output	Input	GPIO Port A5: After reset, the default state is GPIOA5.
(ANA5&CMPD_IN 1)				Input		ANA5 is analog input to channel 5 of ADCA; ANA9 is analog input to channel 9 of ADCC; CMPD_IN1 is negative input 1 of analog comparator D.
GPIOA6	10	—	—	Input/Output	Input	GPIO Port A6: After reset, the default state is GPIOA6.
(ANA6&CMPD_IN 2)				Input		ANA6 is analog input to channel 5 of ADCA; CMPD_IN2 is negative input 2 of analog comparator D.
GPIOA7	9	—	—	Input/Output	Input	GPIO Port A7: After reset, the default state is GPIOA7.
(ANA7&CMPD_IN 3)				Input		ANA7 is analog input to channel 7 of ADCA; CMPD_IN3 is negative input 3 of analog comparator D.
GPIOB0	24	17	11	Input/Output	Input	GPIO Port B0: After reset, the default state is GPIOB0.
(ANB0&CMPB_IN 3)				Input		ANB0 is analog input to channel 0 of ADCB; CMPB_IN3 is positive input 3 of analog comparator B. When used as an analog input, the signal goes to ANB0 and CMPB_IN3. The ADC control register configures this input as ANB0.
GPIOB1	25	18	12	Input/Output	Input	GPIO Port B1: After reset, the default state is GPIOB1.
(ANB1&CMPB_IN 0)				Input		ANB1 is analog input to channel 1 of ADCB; CMPB_IN0 is negative input 0 of analog comparator B. When used as an analog input, the signal goes to ANB1

Table continues on the next page...

Table 2. Signal descriptions (continued)

Signal Name	64 LQFP	48 LQFP	32 LQFP	Type	State During Reset	Signal Description
DACB_O				Analog Output		and CMPB_IN0. The ADC control register configures this input as ANB1. 12-bit digital-to-analog output
GPIOB2	27	20	13	Input/Output	Input	GPIO Port B2: After reset, the default state is GPIOB2.
(ANB2&VERFHB &CMPC_IN3)				Input		ANB2 is analog input to channel 2 of ADCB; VREFHB is analog reference high of ADCB; CMPC_IN3 is positive input 3 of analog comparator C. When used as an analog input, the signal goes to both ANB2 and CMPC_IN3.
GPIOB3	28	21	—	Input/Output	Input	GPIO Port B3: After reset, the default state is GPIOB3.
(ANB3&VREFLB& CMPC_IN0)				Input		ANB3 is analog input to channel 3 of ADCB; VREFLB is analog reference low of ADCB; CMPC_IN0 is negative input 0 of analog comparator C.
GPIOB4	21	14	—	Input/Output	Input	GPIO Port B4: After reset, the default state is GPIOB4.
(ANB4&CMPC_IN 1)				Input		ANB4 is analog input to channel 4 of ADCB; CMPC_IN1 is negative input 1 of analog comparator C.
GPIOB5	20	—	—	Input/Output	Input	GPIO Port B5: After reset, the default state is GPIOB5.
(ANB5&CMPC_IN 2)				Input		ANB5 is analog input to channel 5 of ADCB; CMPC_IN2 is negative input 2 of analog comparator C.
GPIOB6	19	—	—	Input/Output	Input	GPIO Port B6: After reset, the default state is GPIOB6.
(ANB6&CMPB_IN 1)				Input		ANB6 is analog input to channel 6 of ADCB; CMPB_IN1 is negative input 1 of analog comparator B.
GPIOB7	17	—	—	Input/Output	Input	GPIO Port B7: After reset, the default state is GPIOB7.
(ANB7&CMPB_IN 2)				Input		ANB7 is analog input to channel 7 of ADCB; CMPB_IN2 is negative input 2 of analog comparator B.
GPIOC0	3	3	—	Input/Output	Input	GPIO Port C0: After reset, the default state is GPIOC0.
(EXTAL)				Analog Input		The external crystal oscillator input (EXTAL) connects the internal crystal oscillator input to an external crystal or ceramic resonator.
(CLKIN0)				Input		External clock input 0 ¹
GPIOC1	4	4	—	Input/Output	Input	GPIO Port C1: After reset, the default state is GPIOC1.

Table continues on the next page...

Table 2. Signal descriptions (continued)

Signal Name	64 LQFP	48 LQFP	32 LQFP	Type	State During Reset	Signal Description
(XTAL)				Input		The external crystal oscillator output (XTAL) connects the internal crystal oscillator output to an external crystal or ceramic resonator.
GPIOC2	5	5	3	Input/Output	Input	GPIO Port C2: After reset, the default state is GPIOC2.
(TXD0)				Output		SCI0 transmit data output or transmit/receive in single wire operation
(XB_OUT11)				Output		Crossbar module output 11
(XB_IN2)				Input		Crossbar module input 2
(CLKO0)				Output		Buffered clock output 0: the clock source is selected by clockout select (CLKOSEL) bits in the clock output select register (CLKOUT) of the SIM.
GPIOC3	7	6	4	Input/Output	Input	GPIO Port C3: After reset, the default state is GPIOC3.
(TA0)				Input/Output		Quad timer module A channel 0 input/output
(CMPA_O)				Output		Analog comparator A output
(RXD0)				Input		SCI0 receive data input
(CLKIN1)				Input		External clock input 1
GPIOC4	8	7	5	Input/Output	Input	GPIO Port C4: After reset, the default state is GPIOC4.
(TA1)				Input/Output		Quad timer module A channel 1 input/output
(CMPB_O)				Output		Analog comparator B output
(XB_IN6)				Input		Crossbar module input 6
(EWM_OUT_B)				Output		External Watchdog Module output
GPIOC5	18	13	—	Input/Output	Input	GPIO Port C5: After reset, the default state is GPIOC5.
(DACA_O)				Analog Output		12-bit digital-to-analog output
(XB_IN7)				Input		Crossbar module input 7
GPIOC6	31	23	15	Input/Output	Input	GPIO Port C6: After reset, the default state is GPIOC6.
(TA2)				Input/Output		Quad timer module A channel 2 input/output
(XB_IN3)				Input		Crossbar module input 3
(CMP_REF)				Analog Input		Positive input 3 of analog comparator A and B and C.
(SS0_B)				Input/Output		In slave mode, $\overline{SS0_B}$ indicates to the SPI module 0 that the current transfer is to be received.

Table continues on the next page...

Table 2. Signal descriptions (continued)

Signal Name	64 LQFP	48 LQFP	32 LQFP	Type	State During Reset	Signal Description
GPIOC7	32	24	—	Input/Output	Input	GPIO Port C7: After reset, the default state is GPIOC7.
(SS0_B)				Input/Output		In slave mode, SS0_B indicates to the SPI module 0 that the current transfer is to be received.
(TXD0)				Output		SCI0 transmit data output or transmit/receive in single wire operation
(XB_IN8)				Input		Crossbar module input 8
GPIOC8	33	25	16	Input/Output	Input	GPIO Port C8: After reset, the default state is GPIOC8.
(MISO0)				Input/Output		Master in/slave out for SPI0 — In master mode, MISO0 pin is the data input. In slave mode, MISO0 pin is the data output. The MISO line of a slave device is placed in the high-impedance state if the slave device is not selected.
(RXD0)				Input		SCI0 receive data input
(XB_IN9)				Input		Crossbar module input 9
(XB_OUT6)				Output		Crossbar module output 6
GPIOC9	34	26	17	Input/Output	Input	GPIO Port C9: After reset, the default state is GPIOC9.
(SCLK0)				Input/Output		SPI0 serial clock. In master mode, SCLK0 pin is an output, clocking slaved listeners. In slave mode, SCLK0 pin is the data clock input.
(XB_IN4)				Input		Crossbar module input 4
(TXD0)				Output		SCI0 transmit data output or transmit/receive in single wire operation
(XB_OUT8)				Output		Crossbar module output 8
GPIOC10	35	27	18	Input/Output	Input	GPIO Port C10: After reset, the default state is GPIOC10.
(MOSI0)				Input/Output		Master out/slave in for SPI0 — In master mode, MOSI0 pin is the data output. In slave mode, MOSI0 pin is the data input.
(XB_IN5)				Input		Crossbar module input 4
(MISO0)				Input/Output		Master in/slave out for SPI0 — In master mode, MISO0 pin is the data input. In slave mode, MISO0 pin is the data output. The MISO line of a slave device is placed in the high-impedance state if the slave device is not selected.
(XB_OUT9)				Output		Crossbar module output 9
GPIOC11	37	29	—	Input/Output	Input	GPIO Port C11: After reset, the default state is GPIOC11.
(CANTX)				Open-drain Output		CAN transmit data output

Table continues on the next page...

Table 2. Signal descriptions (continued)

Signal Name	64 LQFP	48 LQFP	32 LQFP	Type	State During Reset	Signal Description
(SCL0)				Input/Open-drain Output		I ² C0 serial clock
(TXD1)				Output		SCI1 transmit data output or transmit/receive in single wire operation
GPIOC12	38	30	—	Input/Output	Input	GPIO Port C12: After reset, the default state is GPIOC12.
(CANRX)				Input		CAN receive data input
(SDA0)				Input/Open-drain Output		I ² C0 serial data line
(RXD1)				Input		SCI1 receive data input
GPIOC13	49	37	—	Input/Output	Input	GPIO Port C13: After reset, the default state is GPIOC13.
(TA3)				Input/Output		Quad timer module A channel 3 input/output
(XB_IN6)				Input		Crossbar module input 6
(EWM_OUT_B)				Output		External Watchdog Module output
GPIOC14	55	41	—	Input/Output	Input	GPIO Port C14: After reset, the default state is GPIOC14.
(SDA0)				Input/Open-drain Output		I ² C0 serial data line
(XB_OUT4)				Output		Crossbar module output 4
(PWM_FAULT4)				Input		Disable PWMA output 4
GPIOC15	56	42	—	Input/Output	Input	GPIO Port C15: After reset, the default state is GPIOC15.
(SCL0)				Input/Open-drain Output		I ² C0 serial clock
(XB_OUT5)				Output		Crossbar module output 5
(PWM_FAULT5)				Input		Disable PWMA output 5
GPIOE0	45	33	21	Input/Output	Input	GPIO Port E0: After reset, the default state is GPIOE0.
(PWM_0B)				Input/Output		PWM module A (NanoEdge), submodule 0, output B or input capture B
GPIOE1	46	34	22	Input/Output	Input	GPIO Port E1: After reset, the default state is GPIOE1.
(PWM_0A)				Input/Output		PWM module A (NanoEdge), submodule 0, output A or input capture A
GPIOE2	47	35	23	Input/Output	Input	GPIO Port E2: After reset, the default state is GPIOE2.
(PWMA_1B)				Input/Output		PWM module A (NanoEdge), submodule 1, output B or input capture B
GPIOE3	48	36	24	Input/Output	Input	GPIO Port E3: After reset, the default state is GPIOE3.

Table continues on the next page...

Table 2. Signal descriptions (continued)

Signal Name	64 LQFP	48 LQFP	32 LQFP	Type	State During Reset	Signal Description
(PWMA_1A)				Input/Output		PWM module A (NanoEdge), submodule 1, output A or input capture A
GPIOE4	51	39	25	Input/Output	Input	GPIO Port E4: After reset, the default state is GPIOE4.
(PWMA_2B)				Input/Output		PWM module A (NanoEdge), submodule 2, output B or input capture B
(XB_IN2)				Input		Crossbar module input 2
GPIOE5	52	40	26	Input/Output	Input	GPIO Port E5: After reset, the default state is GPIOE5.
(PWMA_2A)				Input/Output		PWM module A (NanoEdge), submodule 2, output A or input capture A
(XB_IN3)				Input		Crossbar module input 3
GPIOE6	53	—	—	Input/Output	Input	GPIO Port E6: After reset, the default state is GPIOE6.
(PWMA_3B)				Input/Output		PWM module A (NanoEdge), submodule 3, output B or input capture B
(XB_IN4)				Input		Crossbar module input 4
GPIOE7	54	—	—	Input/Output	Input	GPIO Port E7: After reset, the default state is GPIOE7.
(PWMA_3A)				Input/Output		PWM module A (NanoEdge), submodule 3, output A or input capture A
(XB_IN5)				Input		Crossbar module input 5
GPIOF0	36	28	—	Input/Output	Input	GPIO Port F0: After reset, the default state is GPIOF0.
(XB_IN6)				Input		Crossbar module input 6
(SCLK1)				Input/Output		SPI1 serial clock — In master mode, SCLK1 pin is an output, clocking slaved listeners. In slave mode, SCLK1 pin is the data clock input 0.
GPIOF1	50	38	—	Input/Output	Input	GPIO Port F1: After reset, the default state is GPIOF1.
(CLKO1)				Output		Buffered clock output 1: the clock source is selected by clockout select (CLKOSEL) bits in the clock output select register (CLKOUT) of the SIM.
(XB_IN7)				Input		Crossbar module input 7
(CMPD_O)				Output		Analog comparator D output
GPIOF2	39	—	19	Input/Output	Input	GPIO Port F2: After reset, the default state is GPIOF2.
(SCL0)				Input/Open-drain Output		I ² C0 serial clock
(XB_OUT6)				Output		Crossbar module output 6
(MISO1)				Input/Output		Master in/slave out for SPI1 —In master mode, MISO1 pin is the data input. In slave mode, MISO1 pin is the data

Table continues on the next page...

Table 2. Signal descriptions (continued)

Signal Name	64 LQFP	48 LQFP	32 LQFP	Type	State During Reset	Signal Description
						output. The MISO line of a slave device is placed in the high-impedance state if the slave device is not selected.
GPIOF3	40	—	20	Input/Output	Input	GPIO Port F3: After reset, the default state is GPIOF3.
(SDA0)				Input/Open-drain Output		I ² C0 serial data line
(XB_OUT7)				Output		Crossbar module output 7
(MOSI1)				Input/Output		Master out/slave in for SPI1— In master mode, MOSI1 pin is the data output. In slave mode, MOSI1 pin is the data input.
GPIOF4	41	—	—	Input/Output	Input	GPIO Port F4: After reset, the default state is GPIOF4.
(TXD1)				Output		SCI1 transmit data output or transmit/receive in single wire operation
(XB_OUT8)				Output		Crossbar module output 8
(PWMA_0X)				Input/Output		PWM module A (NanoEdge), submodule 0, output X or input capture X
(PWMA_FAULT6)				Input		Disable PWMA output 6
GPIOF5	42	—	—	Input/Output	Input	GPIO Port F5: After reset, the default state is GPIOF5.
(RXD1)				Input		SCI1 receive data input
(XB_OUT9)				Output		Crossbar module output 9
(PWMA_1X)				Input/Output		PWM module A (NanoEdge), submodule 1, output X or input capture X
(PWMA_FAULT7)				Input		Disable PWMA output 7
GPIOF6	58	—	—	Input/Output	Input	GPIO Port F6: After reset, the default state is GPIOF6.
(PWMA_3X)				Input/Output		PWM module A (NanoEdge), submodule 3, output X or input capture X
(XB_IN2)				Input		Crossbar module input 2
GPIOF7	59	—	—	Input/Output	Input	GPIO Port F7: After reset, the default state is GPIOF7.
(CMPC_O)				Output		Analog comparator C output
(SS1_B)				Input/Output		In slave mode, SS1_B indicates to the SPI1 module that the current transfer is to be received.
(XB_IN3)				Input		Crossbar module input 3
GPIOF8	6	—	—	Input/Output	Input	GPIO Port F8: After reset, the default state is GPIOF8.
(RXD0)				Input		SCI0 receive data input
(XB_OUT10)				Output		Crossbar module output 10
(CMPD_O)				Output		Analog comparator D output

Table continues on the next page...

Table 2. Signal descriptions (continued)

Signal Name	64 LQFP	48 LQFP	32 LQFP	Type	State During Reset	Signal Description
(PWMA_2X)						PWM module A (NanoEdge), submodule 2, output X or input capture X

1. If CLKIN is selected as the device's external clock input, then both the GPS_C0 bit (in GPS1) and the EXT_SEL bit (in OCCS oscillator control register (OSCTL)) must be set. Also, the crystal oscillator should be powered down.

2.1 Signal groups

The input and output signals of the MC56F827xx are organized into functional groups, as detailed in the following table.

Table 3. Functional Group Pin Allocations

Functional Group	Number of Pins			
	32QFN	32LQFP	48LQFP	64LQFP
Power Inputs (V_{DD} , V_{DDA}), Power output(V_{CAP})	3	3	5	6
Ground (V_{SS} , V_{SSA})	3	3	4	4
Reset	1	1	1	1
eFlexPWM with NanoEdge ports not including fault pins (for 56F827xx)	6	6	6	8
eFlexPWM without NanoEdge ports not including fault pins	0	0	0	4
Queued Serial Peripheral Interface (QSPI0 and QSPI1) ports	4	4	5	9
Queued Serial Communications Interface (QSCI0 and QSCI1) ports	4	4	7	10
Inter-Integrated Circuit Interface (I ² C0) ports	2	2	4	6
12-bit Analog-to-Digital Converter inputs	6	6	10	16
Analog Comparator inputs/outputs	7/3	7/3	11/4	17/5
12-bit Digital-to-Analog output	2	2	2	2
Quad Timer Module (TMRA and TMRB) ports	3	3	4	4
Controller Area Network (MSCAN)	0	0	2	2
Inter-Module Crossbar inputs/outputs	8/4	8/4	12/6	17/11
Clock inputs/outputs	1/1	1/1	2/2	2/2
JTAG / Enhanced On-Chip Emulation (EOnCE)	4	4	4	4

3 Ordering parts

3.1 Determining valid orderable parts

Valid orderable part numbers are provided on the web. To determine the orderable part numbers for this device, go to nxp.com and perform a part number search for the following device numbers: MC56F82

4 Part identification

4.1 Description

Part numbers for the chip have fields that identify the specific part. You can use the values of these fields to determine the specific part you have received.

4.2 Format

Part numbers for this device have the following format: Q 56F8 2 C F P T PP N

4.3 Fields

This table lists the possible values for each field in the part number (not all combinations are valid):

Field	Description	Values
Q	Qualification status	<ul style="list-style-type: none"> MC = Fully qualified, general market flow PC = Prequalification
56F8	DSC family with flash memory and DSP56800/DSP56800E/DSP56800EX core	<ul style="list-style-type: none"> 56F8
2	DSC subfamily	<ul style="list-style-type: none"> 2
C	Maximum CPU frequency (MHz)	<ul style="list-style-type: none"> 7 = 100 MHz
F	Primary program flash memory size	<ul style="list-style-type: none"> 1 = 16 KB 2 = 32 KB 3 = 48 KB 4 = 64 KB
P	Pin count	<ul style="list-style-type: none"> 3 = 32 6 = 48 8 = 64
T	Temperature range (°C)	<ul style="list-style-type: none"> V = -40 to 105 M = -40 to 125
PP	Package identifier	<ul style="list-style-type: none"> LC = 32LQFP FM = 32QFN

Table continues on the next page...

Field	Description	Values
		<ul style="list-style-type: none"> • LF = 48LQFP • LH = 64LQFP
N	Packaging type	<ul style="list-style-type: none"> • R = Tape and reel • (Blank) = Trays

4.4 Example

This is an example part number: MC56F82748VLH

5 Terminology and guidelines

5.1 Definition: Operating requirement

An *operating requirement* is a specified value or range of values for a technical characteristic that you must guarantee during operation to avoid incorrect operation and possibly decreasing the useful life of the chip.

5.1.1 Example

This is an example of an operating requirement:

Symbol	Description	Min.	Max.	Unit
V _{DD}	1.0 V core supply voltage	0.9	1.1	V

5.2 Definition: Operating behavior

Unless otherwise specified, an *operating behavior* is a specified value or range of values for a technical characteristic that are guaranteed during operation if you meet the operating requirements and any other specified conditions.

5.2.1 Example

This is an example of an operating behavior:

Terminology and guidelines

Symbol	Description	Min.	Max.	Unit
I_{WP}	Digital I/O weak pullup/pulldown current	10	130	μA

5.3 Definition: Attribute

An *attribute* is a specified value or range of values for a technical characteristic that are guaranteed, regardless of whether you meet the operating requirements.

5.3.1 Example

This is an example of an attribute:

Symbol	Description	Min.	Max.	Unit
C_{IN_D}	Input capacitance: digital pins	—	7	pF

5.4 Definition: Rating

A *rating* is a minimum or maximum value of a technical characteristic that, if exceeded, may cause permanent chip failure:

- *Operating ratings* apply during operation of the chip.
- *Handling ratings* apply when the chip is not powered.

5.4.1 Example

This is an example of an operating rating:

Symbol	Description	Min.	Max.	Unit
V_{DD}	1.0 V core supply voltage	-0.3	1.2	V

5.5 Result of exceeding a rating

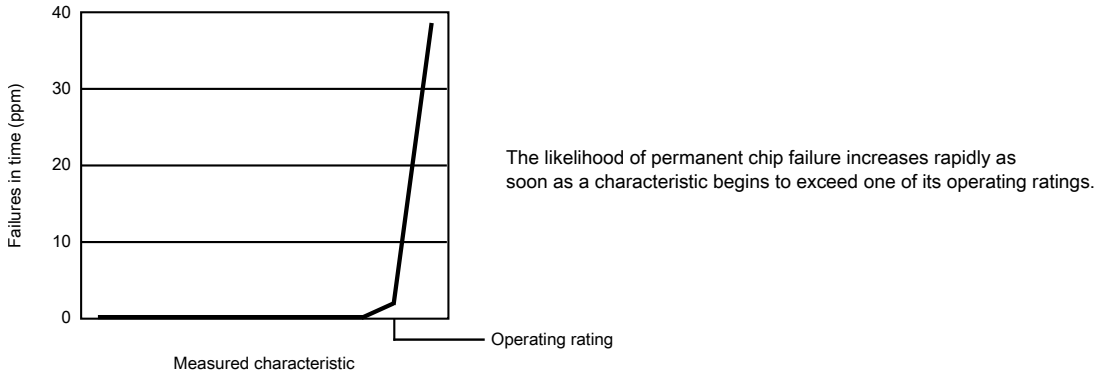

5.6 Relationship between ratings and operating requirements

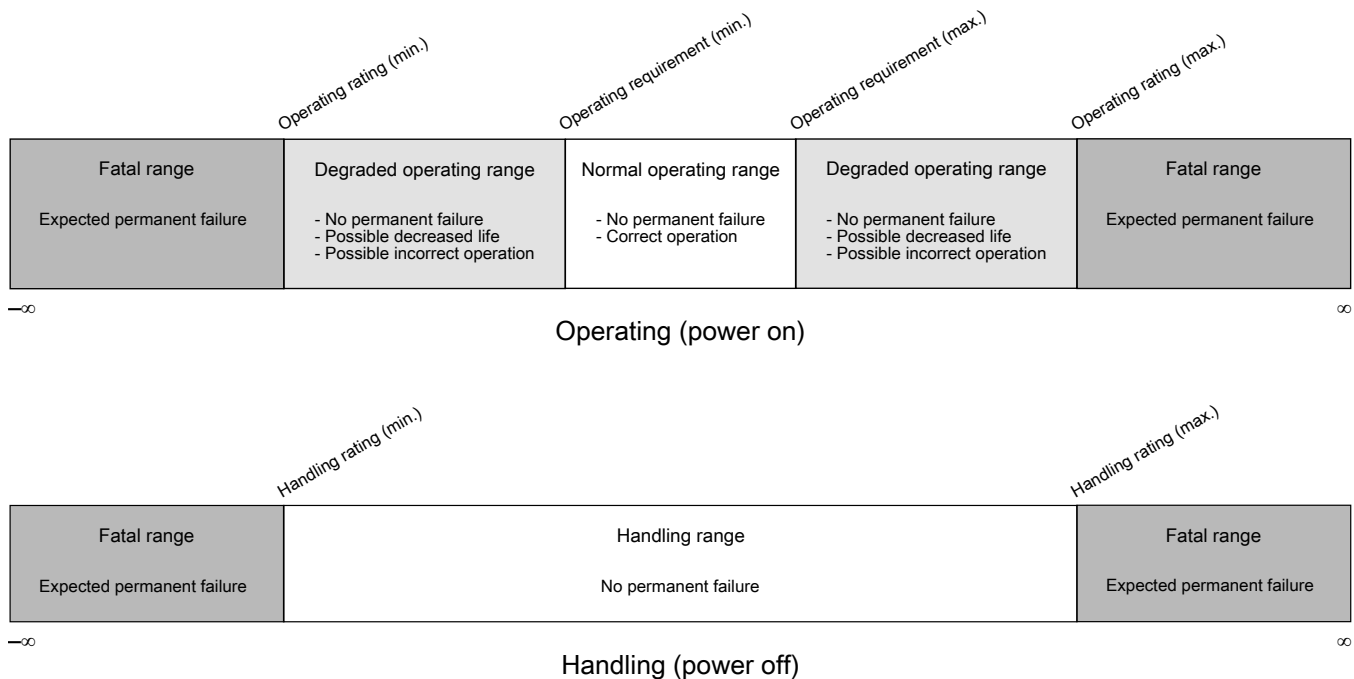

5.7 Guidelines for ratings and operating requirements

Follow these guidelines for ratings and operating requirements:

- Never exceed any of the chip's ratings.
- During normal operation, don't exceed any of the chip's operating requirements.
- If you must exceed an operating requirement at times other than during normal operation (for example, during power sequencing), limit the duration as much as possible.

5.8 Definition: Typical value

A *typical value* is a specified value for a technical characteristic that:

- Lies within the range of values specified by the operating behavior
- Given the typical manufacturing process, is representative of that characteristic during operation when you meet the typical-value conditions or other specified conditions

Typical values are provided as design guidelines and are neither tested nor guaranteed.

5.8.1 Example 1

This is an example of an operating behavior that includes a typical value:

Symbol	Description	Min.	Typ.	Max.	Unit
I_{WP}	Digital I/O weak pullup/pulldown current	10	70	130	μA

5.8.2 Example 2

This is an example of a chart that shows typical values for various voltage and temperature conditions:

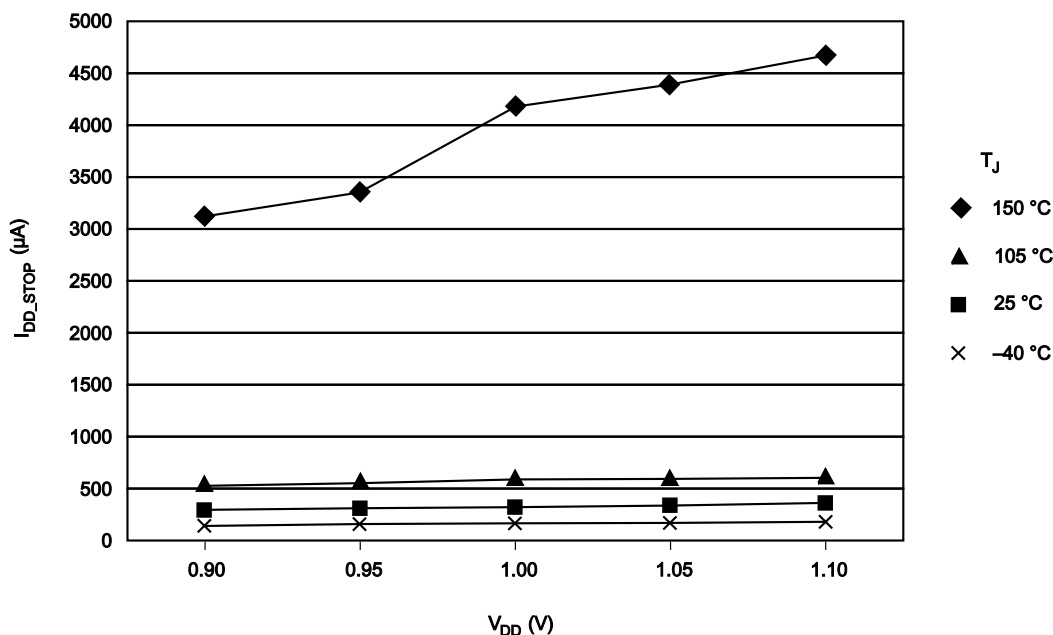

5.9 Typical value conditions

Typical values assume you meet the following conditions (or other conditions as specified):

Symbol	Description	Value	Unit
T_A	Ambient temperature	25	°C
V_{DD}	3.3 V supply voltage	3.3	V

6 Ratings

6.1 Thermal handling ratings

Symbol	Description	Min.	Max.	Unit	Notes
T_{STG}	Storage temperature	-55	150	°C	1
T_{SDR}	Solder temperature, lead-free	—	260	°C	2

1. Determined according to JEDEC Standard JESD22-A103, *High Temperature Storage Life*.
2. Determined according to IPC/JEDEC Standard J-STD-020, *Moisture/Reflow Sensitivity Classification for Nonhermetic Solid State Surface Mount Devices*.

6.2 Moisture handling ratings

Symbol	Description	Min.	Max.	Unit	Notes
MSL	Moisture sensitivity level	—	3	—	1

1. Determined according to IPC/JEDEC Standard J-STD-020, *Moisture/Reflow Sensitivity Classification for Nonhermetic Solid State Surface Mount Devices*.

6.3 ESD handling ratings

Although damage from electrostatic discharge (ESD) is much less common on these devices than on early CMOS circuits, use normal handling precautions to avoid exposure to static discharge. Qualification tests are performed to ensure that these devices can withstand exposure to reasonable levels of static without suffering any permanent damage.

All ESD testing is in conformity with AEC-Q100 Stress Test Qualification. During the device qualification ESD stresses were performed for the human body model (HBM), the machine model (MM), and the charge device model (CDM).

All latch-up testing is in conformity with AEC-Q100 Stress Test Qualification.

A device is defined as a failure if after exposure to ESD pulses, the device no longer meets the device specification. Complete DC parametric and functional testing is performed as per the applicable device specification at room temperature followed by hot temperature, unless specified otherwise in the device specification.

Table 4. ESD/Latch-up Protection

Characteristic ¹	Min	Max	Unit
ESD for Human Body Model (HBM)	-2000	+2000	V
ESD for Machine Model (MM)	-200	+200	V
ESD for Charge Device Model (CDM)	-500	+500	V
Latch-up current at TA= 85°C (I _{LAT})	-100	+100	mA

1. Parameter is achieved by design characterization on a small sample size from typical devices under typical conditions unless otherwise noted.

6.4 Voltage and current operating ratings

Absolute maximum ratings are stress ratings only, and functional operation at the maxima is not guaranteed. Stress beyond the limits specified in [Table 5](#) may affect device reliability or cause permanent damage to the device.

NOTE

If the voltage difference between VDD and VDDA or VSS and VSSA is too large, then the device can malfunction or be permanently damaged. The restrictions are:

- **At all times, it is recommended that the voltage difference of VDD - VSS be within +/-200 mV of the voltage difference of VDDA - VSSA**, including power ramp up and ramp down; see additional requirements in [Table 6](#). Failure to do this recommendation may result in a

harmful leakage current through the substrate, between the VDD/VSS and VDDA/VSSA pad cells. This harmful leakage current could prevent the device from operating after power up.

- **At all times, to avoid permanent damage to the part, the voltage difference between VDD and VDDA must absolutely be limited to 0.3 V; see Table 5.**
- **At all times, to avoid permanent damage to the part, the voltage difference between VSS and VSSA must absolutely be limited to 0.3 V; see Table 5.**

Table 5. Absolute Maximum Ratings ($V_{SS} = 0\text{ V}$, $V_{SSA} = 0\text{ V}$)

Characteristic	Symbol	Notes ¹	Min	Max	Unit
Supply Voltage Range	V_{DD}		-0.3	4.0	V
Analog Supply Voltage Range	V_{DDA}		-0.3	4.0	V
ADC High Voltage Reference	V_{REFHx}		-0.3	4.0	V
Voltage difference V_{DD} to V_{DDA}	ΔV_{DD}		-0.3	0.3	V
Voltage difference V_{SS} to V_{SSA}	ΔV_{SS}		-0.3	0.3	V
Digital Input Voltage Range	V_{IN}	Pin Group 1	-0.3	5.5	V
$\overline{\text{RESET}}$ Input Voltage Range	V_{IN_RESET}	Pin Group 2	-0.3	4.0	V
Oscillator Input Voltage Range	V_{OSC}	Pin Group 4	-0.4	4.0	V
Analog Input Voltage Range	V_{INA}	Pin Group 3	-0.3	4.0	V
Input clamp current, per pin ($V_{IN} < V_{SS} - 0.3\text{ V}$) ^{2, 3}	V_{IC}		—	-5.0	mA
Output clamp current, per pin ⁴	V_{OC}		—	± 20.0	mA
Contiguous pin DC injection current—regional limit sum of 16 contiguous pins	I_{ICont}		-25	25	mA
Output Voltage Range (normal push-pull mode)	V_{OUT}	Pin Group 1, 2	-0.3	4.0	V
Output Voltage Range (open drain mode)	V_{OUTOD}	Pin Group 1	-0.3	5.5	V
$\overline{\text{RESET}}$ Output Voltage Range	V_{OUTOD_RESET}	Pin Group 2	-0.3	4.0	V
DAC Output Voltage Range	V_{OUT_DAC}	Pin Group 5	-0.3	4.0	V
Ambient Temperature	T_A	V temperature	-40	105	°C
		M temperature	-40	125	
Junction Temperature	T_j	V temperature	-40	115	°C
		M temperature	-40	135	
Storage Temperature Range (Extended Industrial)	T_{STG}		-55	150	°C

1. Default Mode

- Pin Group 1: GPIO, TDI, TDO, TMS, TCK
- Pin Group 2: $\overline{\text{RESET}}$
- Pin Group 3: ADC and Comparator Analog Inputs
- Pin Group 4: XTAL, EXTAL
- Pin Group 5: DAC analog output

2. Continuous clamp current

General

3. All 5 volt tolerant digital I/O pins are internally clamped to V_{SS} through a ESD protection diode. There is no diode connection to V_{DD} . If V_{IN} greater than $VDIO_MIN (= V_{SS}-0.3\text{ V})$ is observed, then there is no need to provide current limiting resistors at the pads. If this limit cannot be observed, then a current limiting resistor is required.
4. I/O is configured as push-pull mode.

7 General

7.1 General characteristics

The device is fabricated in high-density, low-power CMOS with 5 V–tolerant TTL-compatible digital inputs, except for the \overline{RESET} pin which is 3.3V only. The term “5 V–tolerant” refers to the capability of an I/O pin, built on a 3.3 V–compatible process technology, to withstand a voltage up to 5.5 V without damaging the device.

5 V–tolerant I/O is desirable because many systems have a mixture of devices designed for 3.3 V and 5 V power supplies. In such systems, a bus may carry both 3.3 V– and 5 V–compatible I/O voltage levels (a standard 3.3 V I/O is designed to receive a maximum voltage of $3.3\text{ V} \pm 10\%$ during normal operation without causing damage). This 5 V–tolerant capability therefore offers the power savings of 3.3 V I/O levels combined with the ability to receive 5 V levels without damage.

Absolute maximum ratings in [Table 5](#) are stress ratings only, and functional operation at the maximum is not guaranteed. Stress beyond these ratings may affect device reliability or cause permanent damage to the device.

Unless otherwise stated, all specifications within this chapter apply to the temperature range specified in [Table 5](#) over the following supply ranges: $V_{SS}=V_{SSA}=0\text{V}$, $V_{DD}=V_{DDA}=3.0\text{V}$ to 3.6V , $CL \leq 50\text{ pF}$, $f_{OP}=50\text{MHz}$.

CAUTION

This device contains protective circuitry to guard against damage due to high static voltage or electrical fields. However, normal precautions are advised to avoid application of any voltages higher than maximum-rated voltages to this high-impedance circuit. Reliability of operation is enhanced if unused inputs are tied to an appropriate voltage level.

7.2 AC electrical characteristics

Tests are conducted using the input levels specified in Table 8. Unless otherwise specified, propagation delays are measured from the 50% to the 50% point, and rise and fall times are measured between the 10% and 90% points, as shown in Figure 3.

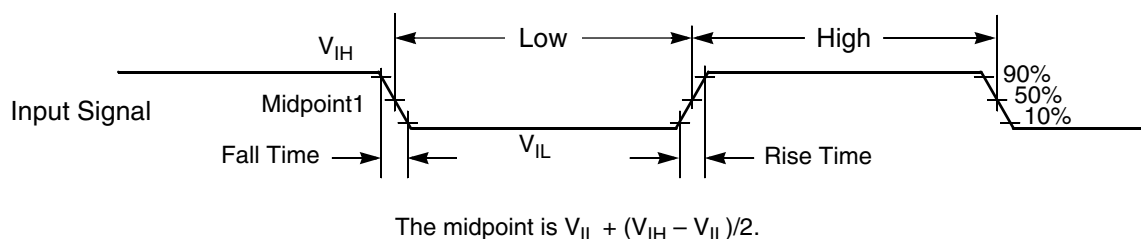

Figure 3. Input signal measurement references

Figure 4 shows the definitions of the following signal states:

- Active state, when a bus or signal is driven, and enters a low impedance state
- Tri-stated, when a bus or signal is placed in a high impedance state
- Data Valid state, when a signal level has reached V_{OL} or V_{OH}
- Data Invalid state, when a signal level is in transition between V_{OL} and V_{OH}

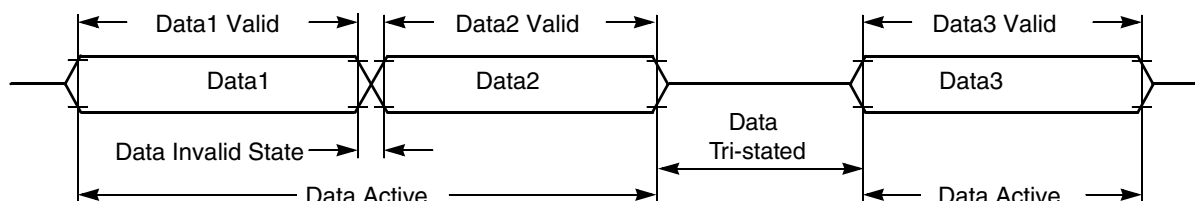

Figure 4. Signal states

7.3 Nonswitching electrical specifications

7.3.1 Voltage and current operating requirements

This section includes information about recommended operating conditions.

NOTE

Recommended V_{DD} ramp rate is less than 200 ms.

Table 6. Recommended Operating Conditions ($V_{REFLX}=0V$, $V_{SSA}=0V$, $V_{SS}=0V$)

Characteristic	Symbol	Notes ¹	Min	Typ	Max	Unit
Supply voltage	V_{DD} , V_{DDA}		2.7	3.3	3.6	V

Table continues on the next page...

Table 6. Recommended Operating Conditions ($V_{REFLx}=0V$, $V_{SSA}=0V$, $V_{SS}=0V$) (continued)

Characteristic	Symbol	Notes ¹	Min	Typ	Max	Unit
ADC (Cyclic) Reference Voltage High	V_{REFHA} V_{REFHB}		$V_{DDA}-0.6$		V_{DDA}	V
Voltage difference V_{DD} to V_{DDA}	ΔV_{DD}		-0.1	0	0.1	V
Voltage difference V_{SS} to V_{SSA}	ΔV_{SS}		-0.1	0	0.1	V
Input Voltage High (digital inputs)	V_{IH}	Pin Group 1	$0.7 \times V_{DD}$		5.5	V
\overline{RESET} Voltage High	V_{IH_RESET}	Pin Group 2	$0.7 \times V_{DD}$	—	V_{DD}	V
Input Voltage Low (digital inputs)	V_{IL}	Pin Groups 1, 2			$0.35 \times V_{DD}$	V
Oscillator Input Voltage High XTAL driven by an external clock source	V_{IHOSC}	Pin Group 4	2.0		$V_{DD} + 0.3$	V
Oscillator Input Voltage Low	V_{ILOSC}	Pin Group 4	-0.3		0.8	V
Output Source Current High (at V_{OH} min.) • Programmed for low drive strength • Programmed for high drive strength	I_{OH}	Pin Group 1 Pin Group 1	— —		-2 -9	mA
Output Source Current Low (at V_{OL} max.) ^{2,3} • Programmed for low drive strength • Programmed for high drive strength	I_{OL}	Pin Groups 1, 2 Pin Groups 1, 2	— —		2 9	mA

1. Default Mode

- Pin Group 1: GPIO, TDI, TDO, TMS, TCK
- Pin Group 2: \overline{RESET}
- Pin Group 3: ADC and Comparator Analog Inputs
- Pin Group 4: XTAL, EXTAL
- Pin Group 5: DAC analog output

2. Total IO sink current and total IO source current are limited to 75 mA each

3. Contiguous pin DC injection current of regional limit—including sum of negative injection currents or sum of positive injection currents of 16 contiguous pins—is 25 mA.

7.3.2 LVD and POR operating requirements**Table 7. PMC Low-Voltage Detection (LVD) and Power-On Reset (POR) Parameters**

Characteristic	Symbol	Min	Typ	Max	Unit
POR Assert Voltage ¹	POR		2.0		V
POR Release Voltage ²	POR		2.7		V
LVI_2p7 Threshold Voltage			2.73		V
LVI_2p2 Threshold Voltage			2.23		V

1. During 3.3-volt V_{DD} power supply ramp down

2. During 3.3-volt V_{DD} power supply ramp up (gated by LVI_2p7)

7.3.3 Voltage and current operating behaviors

The following table provides information about power supply requirements and I/O pin characteristics.

Table 8. DC Electrical Characteristics at Recommended Operating Conditions

Characteristic	Symbol	Notes ¹	Min	Typ	Max	Unit	Test Conditions
Output Voltage High	V_{OH}	Pin Group 1	$V_{DD} - 0.5$	—	—	V	$I_{OH} = I_{OHmax}$
Output Voltage Low	V_{OL}	Pin Groups 1, 2	—	—	0.5	V	$I_{OL} = I_{OLmax}$
Digital Input Current High pull-up enabled or disabled	I_{IH}	Pin Group 1 Pin Group 2	—	0	+/- 2.5	μA	$V_{IN} = 2.4 V$ to $5.5 V$ $V_{IN} = 2.4 V$ to V_{DD}
Comparator Input Current High	I_{IHC}	Pin Group 3	—	0	+/- 2	μA	$V_{IN} = V_{DDA}$
Oscillator Input Current High	I_{IHOSC}	Pin Group 3	—	0	+/- 2	μA	$V_{IN} = V_{DDA}$
Digital Input Current Low pull-up disabled	I_{IL}	Pin Groups 1, 2	—	0	+/- 0.5	μA	$V_{IN} = 0V$
Internal Pull-Up Resistance	$R_{Pull-Up}$		20	—	50	k Ω	—
Internal Pull-Down Resistance	$R_{Pull-Down}$		20	—	50	k Ω	—
Comparator Input Current Low	I_{ILC}	Pin Group 3	—	0	+/- 2	μA	$V_{IN} = 0V$
Oscillator Input Current Low	I_{ILOSC}	Pin Group 3	—	0	+/- 2	μA	$V_{IN} = 0V$
DAC Output Voltage Range	V_{DAC}	Pin Group 5	Typically $V_{SSA} + 40mV$	—	Typically $V_{DDA} - 40mV$	V	$R_{LD} = 3 k\Omega$ $C_{LD} = 400 pF$
Output Current ^{2, 3} High Impedance State	I_{OZ}	Pin Groups 1, 2	—	0	+/- 1	μA	—
Schmitt Trigger Input Hysteresis	V_{HYS}	Pin Groups 1, 2	$0.06 \times V_{DD}$	—	—	V	—

1. Default Mode

- Pin Group 1: GPIO, TDI, TDO, TMS, TCK
- Pin Group 2: \overline{RESET}
- Pin Group 3: ADC and Comparator Analog Inputs
- Pin Group 4: XTAL, EXTAL
- Pin Group 5: DAC

2. See the following figure " I_{IN}/I_{OZ} vs. V_{IN} (typical; pull-up disabled)" .

3. To minimize the excessive leakage current from digital pin, input signal should **not** stay between 1.1 V and $0.7 \times V_{DD}$ for prolonged time.

General

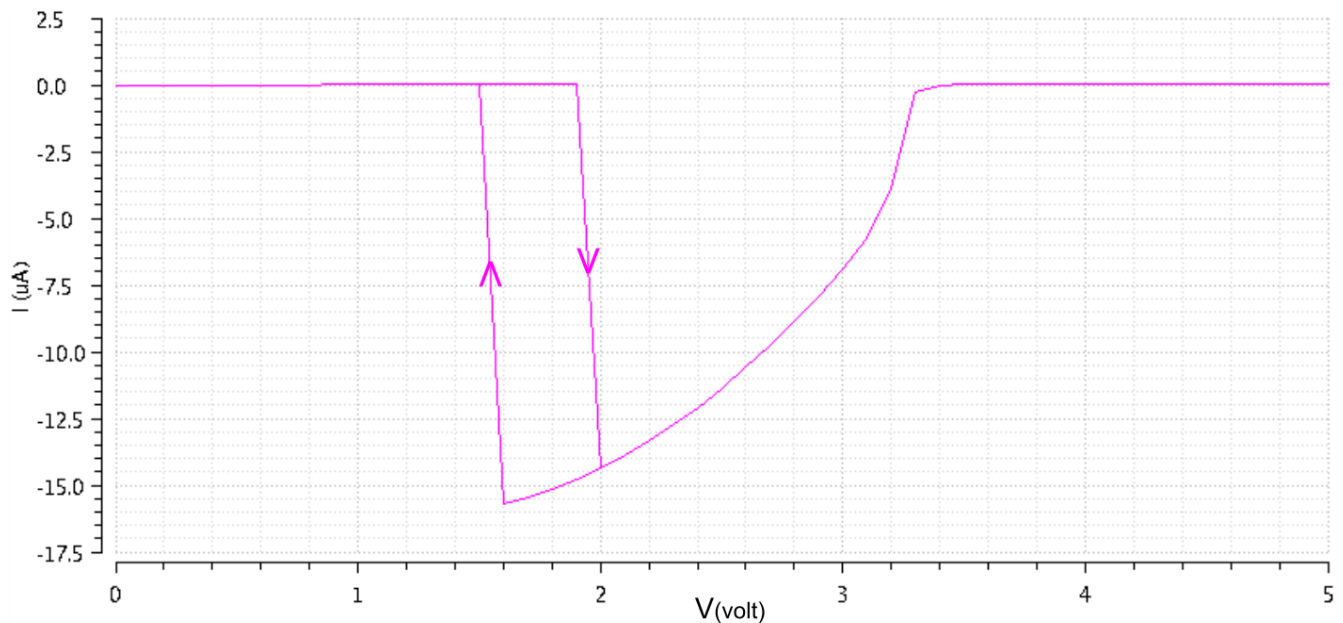

Figure 5. I_{IN}/I_{OZ} vs. V_{IN} (typical; pull-up disabled) (design simulation)

7.3.4 Power mode transition operating behaviors

Parameters listed are guaranteed by design.

NOTE

All address and data buses described here are internal.

Table 9. Reset, stop, wait, and interrupt timing

Characteristic	Symbol	Typical Min	Typical Max	Unit	See Figure
Minimum $\overline{\text{RESET}}$ Assertion Duration	t_{RA}	16 ¹	—	ns	—
$\overline{\text{RESET}}$ deassertion to First Address Fetch	t_{RDA}	$865 \times T_{\text{OSC}} + 8 \times T$		ns	—
Delay from Interrupt Assertion to Fetch of first instruction (exiting Stop)	t_{IF}	361.3	570.9	ns	—

1. If the $\overline{\text{RESET}}$ pin filter is enabled by setting the RST_FLT bit in the SIM_CTRL register to 1, the minimum pulse assertion must be greater than 21 ns. Recommended a capacitor of up to 0.1 μF on RESET.

NOTE

In Table 9, T = system clock cycle and T_{OSC} = oscillator clock cycle. For an operating frequency of 50MHz, $T=20$ ns. At 4 MHz (used coming out of reset and stop modes), $T=250$ ns.

Table 10. Power mode transition behavior

Symbol	Description	Min	Max	Unit	Notes ¹
T _{POR}	After a POR event, the amount of delay from when V _{DD} reaches 2.7 V to when the first instruction executes (over the operating temperature range).	199	225	µs	
	STOP mode to RUN mode	6.79	7.27.31	µs	2
	LPS mode to LPRUN mode	240.9	551	µs	3
	VLPS mode to VLPRUN mode	1424	1459	µs	4
	WAIT mode to RUN mode	0.570	0.620	µs	5
	LPWAIT mode to LPRUN mode	237.2	554	µs	3
	VLPWAIT mode to VLPRUN mode	1413	1500	µs	4

1. Wakeup times are measured from GPIO toggle for wakeup till GPIO toggle at the wakeup interrupt subroutine from respective stop/wait mode.
2. Clock configuration: CPU clock=4 MHz. System clock source is 8 MHz IRC in normal mode.
3. CPU clock = 200 KHz and 8 MHz IRC on standby. Exit by an interrupt on PORTC GPIO.
4. Using 64 KHz external clock; CPU Clock = 32KHz. Exit by an interrupt on PortC GPIO.
5. Clock configuration: CPU and system clocks= 100 MHz. Bus Clock = 50 MHz. .Exit by interrupt on PORTC GPIO

7.3.5 Power consumption operating behaviors

Table 11. Current Consumption (mA)

Mode	Maximum Frequency	Conditions	Typical at 3.3 V, 25°C		Maximum at 3.6 V, 105°C		Maximum at 3.6V, 125°C	
			I _{DD} ¹	I _{DDA}	I _{DD} ¹	I _{DDA}	I _{DD} ¹	I _{DDA}
RUN1	100 MHz	<ul style="list-style-type: none"> • 100 MHz Core • 50 MHz Peripheral clock • Regulators are in full regulation • Relaxation Oscillator on • PLL powered on • Continuous MAC instructions with fetches from Program Flash • All peripheral modules enabled. TMRs and SCIs using 1X peripheral clock • NanoEdge within eFlexPWM using 2X peripheral clock • ADC/DAC (only one 12-bit DAC and all 6-bit DACs) powered on and clocked • Comparator powered on 	38.1	9.9	53.5	13.2	53.5	13.2
RUN2	50 MHz	<ul style="list-style-type: none"> • 50 MHz Core and Peripheral clock • Regulators are in full regulation • Relaxation Oscillator on • PLL powered on • Continuous MAC instructions with fetches from Program Flash • All peripheral modules enabled. TMRs and SCIs using 1X peripheral clock • NanoEdge within eFlexPWM using 2X peripheral clock 	27.6	9.9	43.5	13.2	43.5	14.0

Table continues on the next page...

Table 11. Current Consumption (mA) (continued)

Mode	Maximum Frequency	Conditions	Typical at 3.3 V, 25°C		Maximum at 3.6 V, 105°C		Maximum at 3.6V, 125°C	
			I _{DD} ¹	I _{DDA}	I _{DD} ¹	I _{DDA}	I _{DD} ¹	I _{DDA}
		<ul style="list-style-type: none"> • ADC/DAC (only one 12-bit DAC and all 6-bit DACs) powered on and clocked • Comparator powered on 						
WAIT	50 MHz	<ul style="list-style-type: none"> • 50 MHz Core and Peripheral clock • Regulators are in full regulation • Relaxation Oscillator on • PLL powered on • Processor Core in WAIT state • All Peripheral modules enabled. • TMRs and SCIs using 1X Clock • NanoEdge within PWMA using 2X clock • ADC/DAC (single 12-bit DAC, all 6-bit DACs), Comparator powered off 	24.0	—	41.3	—	41.3	—
STOP	4 MHz	<ul style="list-style-type: none"> • 4 MHz Device Clock • Regulators are in full regulation • Relaxation Oscillator on • PLL powered off • Processor Core in STOP state • All peripheral module and core clocks are off • ADC/DAC/Comparator powered off 	6.3	—	19.4	—	19.4	—
LPRUN (LsRUN)	2 MHz	<ul style="list-style-type: none"> • 200 kHz Device Clock from Relaxation Oscillator's (ROSC) low speed clock • ROSC in standby mode • Regulators are in standby • PLL disabled • Repeat NOP instructions • All peripheral modules enabled, except NanoEdge and cyclic ADCs. One 12-bit DAC and all 6-bit DACs enabled. • Simple loop with running from platform instruction buffer 	2.8	3.1	11.1	4.0	13.0	4.0
LPWAIT (LsWAIT)	2 MHz	<ul style="list-style-type: none"> • 200 kHz Device Clock from Relaxation Oscillator's (ROSC) low speed clock • ROSC in standby mode • Regulators are in standby • PLL disabled • All peripheral modules enabled, except NanoEdge and cyclic ADCs. One 12-bit DAC and all 6-bit DACs enabled.² • Processor core in wait mode 	2.7	3.1	11.1	4.0	13.0	4.0
LPSTOP (LsSTOP)	2 MHz	<ul style="list-style-type: none"> • 200 kHz Device Clock from Relaxation Oscillator's (ROSC) low speed clock • ROSC in standby mode • Regulators are in standby • PLL disabled • Only PITs and COP enabled; other peripheral modules disabled and clocks gated off² • Processor core in stop mode 	1.2	—	9.1	—	12.0	—
VLPRUN	200 kHz	<ul style="list-style-type: none"> • 32 kHz Device Clock • Clocking by a 64 kHz external clock source 	0.7	—	7.5	—	10.0	—

Table continues on the next page...

Table 11. Current Consumption (mA) (continued)

Mode	Maximum Frequency	Conditions	Typical at 3.3 V, 25°C		Maximum at 3.6 V, 105°C		Maximum at 3.6V, 125°C	
			I _{DD} ¹	I _{DDA}	I _{DD} ¹	I _{DDA}	I _{DD} ¹	I _{DDA}
		<ul style="list-style-type: none"> Oscillator in power down All ROSCs disabled Large regulator is in standby Small regulator is disabled PLL disabled Repeat NOP instructions All peripheral modules, except COP and EWM, disabled and clocks gated off Simple loop running from platform instruction buffer 						
VLPWAIT	200 kHz	<ul style="list-style-type: none"> 32 kHz Device Clock Clocked by a 64 kHz external clock source Oscillator in power down All ROSCs disabled Large regulator is in standby Small regulator is disabled PLL disabled All peripheral modules, except COP, disabled and clocks gated off Processor core in wait mode 	0.7	—	7.5	—	10.0	—
VLPSTOP	200 kHz	<ul style="list-style-type: none"> 32 kHz Device Clock Clocked by a 64 kHz external clock source Oscillator in power down All ROSCs disabled Large regulator is in standby. Small regulator is disabled. PLL disabled All peripheral modules, except COP, disabled and clocks gated off Processor core in stop mode 	0.7	—	7.5	—	10.0	—

1. No output switching, all ports configured as inputs, all inputs low, no DC loads.
2. In all chip LP modes and flash memory VLP modes, the maximum frequency for flash memory operation is 500 kHz due to the fixed frequency ratio of 1:2 between the CPU clock and the flash clock when running with 2 MHz external clock input and CPU running at 1 MHz.

7.3.6 Designing with radiated emissions in mind

To find application notes that provide guidance on designing your system to minimize interference from radiated emissions:

1. Go to www.nxp.com.
2. Perform a keyword search for “EMC design.”

7.3.7 Capacitance attributes

Table 12. Capacitance attributes

Description	Symbol	Min.	Typ.	Max.	Unit
Input capacitance	C_{IN}	—	10	—	pF
Output capacitance	C_{OUT}	—	10	—	pF

7.4 Switching specifications

7.4.1 Device clock specifications

Table 13. Device clock specifications

Symbol	Description	Min.	Max.	Unit	Notes
Normal run mode					
f_{SYSCLK}	Device (system and core) clock frequency <ul style="list-style-type: none"> • using relaxation oscillator • using external clock source 	0.001 0	100 100	MHz	
f_{BUS}	Bus clock	—	50	MHz	

7.4.2 General switching timing

Table 14. Switching timing

Symbol	Description	Min	Max	Unit	Notes
	GPIO pin interrupt pulse width ¹ Synchronous path	1.5		IP Bus Clock Cycles	
	Port rise and fall time (high drive strength), Slew disabled $2.7 \leq V_{DD} \leq 3.6V$.	5.5	15.1	ns	
	Port rise and fall time (high drive strength), Slew enabled $2.7 \leq V_{DD} \leq 3.6V$.	1.5	6.8	ns	2
	Port rise and fall time (low drive strength). Slew disabled $2.7 \leq V_{DD} \leq 3.6V$	8.2	17.8	ns	
	Port rise and fall time (low drive strength). Slew enabled $2.7 \leq V_{DD} \leq 3.6V$	3.2	9.2	ns	3

1. Applies to a pin only when it is configured as GPIO and configured to cause an interrupt by appropriately programming GPIO_n_IPOLR and GPIO_n_IENR.
2. 75 pF load
3. 15 pF load

7.5 Thermal specifications

7.5.1 Thermal operating requirements

Table 15. Thermal operating requirements

Symbol	Description		Min	Max	Unit
T_J	Die junction temperature	V	-40	115	°C
		M	-40	135	°C
T_A	Ambient temperature	V	-40	105	°C
		M	-40	125	°C

7.5.2 Thermal attributes

This section provides information about operating temperature range, power dissipation, and package thermal resistance. Power dissipation on I/O pins is usually small compared to the power dissipation in on-chip logic and voltage regulator circuits, and it is user-determined rather than being controlled by the MCU design. To account for $P_{I/O}$ in power calculations, determine the difference between actual pin voltage and V_{SS} or V_{DD} and multiply by the pin current for each I/O pin. Except in cases of unusually high pin current (heavy loads), the difference between pin voltage and V_{SS} or V_{DD} is very small.

See [Thermal design considerations](#) for more detail on thermal design considerations.

Board type	Symbol	Description	32 QFN	32 LQFP	48 LQFP	64 LQFP	Unit	Notes
Single-layer (1s)	$R_{\theta JA}$	Thermal resistance, junction to ambient (natural convection)	96	83	70	64	°C/W	,
Four-layer (2s2p)	$R_{\theta JA}$	Thermal resistance, junction to ambient (natural convection)	33	55	46	46	°C/W	1,
Single-layer (1s)	$R_{\theta JMA}$	Thermal resistance, junction to ambient	80	70	57	52	°C/W	1,2

Table continues on the next page...

Peripheral operating requirements and behaviors

Board type	Symbol	Description	32 QFN	32 LQFP	48 LQFP	64 LQFP	Unit	Notes
		(200 ft./min. air speed)						
Four-layer (2s2p)	$R_{\theta JMA}$	Thermal resistance, junction to ambient (200 ft./min. air speed)	27	49	39	39	°C/W	1,2
—	$R_{\theta JB}$	Thermal resistance, junction to board	12	31	23	28	°C/W	
—	$R_{\theta JC}$	Thermal resistance, junction to case	1.8	22	17	15	°C/W	
—	Ψ_{JT}	Thermal characterization parameter, junction to package top outside center (natural convection)	6	5	3	3	°C/W	

1. Junction temperature is a function of die size, on-chip power dissipation, package thermal resistance, mounting site (board) temperature, ambient temperature, air flow, power dissipation of other components on the board, and board thermal resistance.
2. Determined according to JEDEC Standard JESD51-6, *Integrated Circuits Thermal Test Method Environmental Conditions – Forced Convection (Moving Air)* with the board horizontal.

8 Peripheral operating requirements and behaviors

8.1 Core modules

8.1.1 JTAG timing

Table 16. JTAG timing

Characteristic	Symbol	Min	Max	Unit	See Figure
TCK frequency of operation	f_{OP}	DC	SYS_CLK/ 8	MHz	Figure 6
TCK clock pulse width	t_{PW}	50	—	ns	Figure 6
TMS, TDI data set-up time	t_{DS}	5	—	ns	Figure 7

Table continues on the next page...

Table 16. JTAG timing (continued)

Characteristic	Symbol	Min	Max	Unit	See Figure
TMS, TDI data hold time	t_{DH}	5	—	ns	Figure 7
TCK low to TDO data valid	t_{DV}	—	30	ns	Figure 7
TCK low to TDO tri-state	t_{TS}	—	30	ns	Figure 7

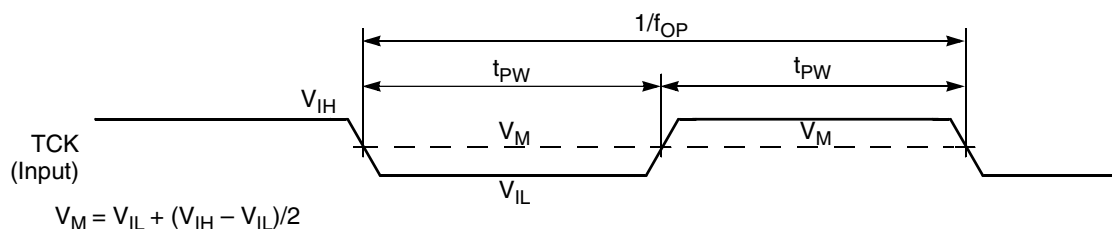

Figure 6. Test clock input timing diagram

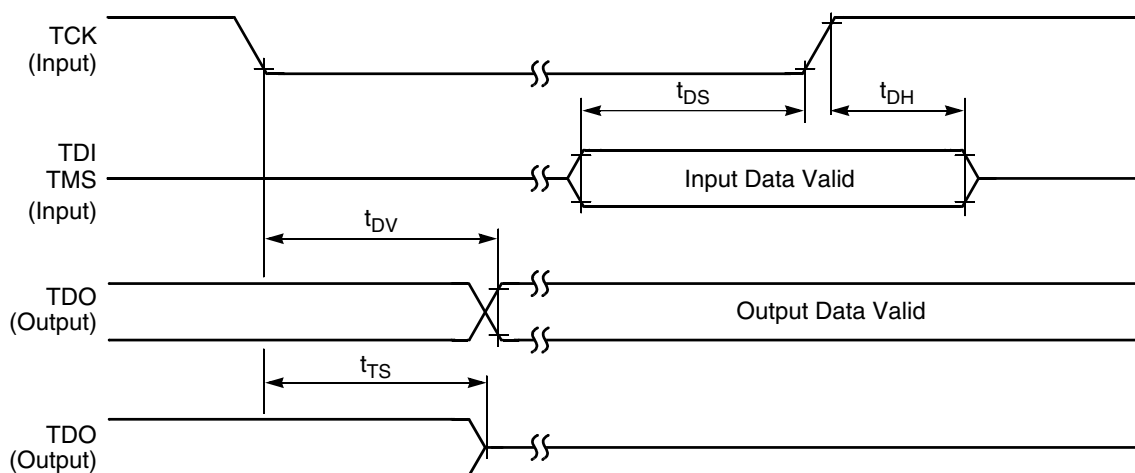

Figure 7. Test access port timing diagram

8.2 System modules

8.2.1 Voltage regulator specifications

The voltage regulator supplies approximately 1.2 V to the MC56F82xxx's core logic. For proper operations, the voltage regulator requires an external 2.2 μF capacitor on each V_{CAP} pin. Ceramic and tantalum capacitors tend to provide better performance tolerances. The output voltage can be measured directly on the V_{CAP} pin. The specifications for this regulator are shown in [Table 17](#).

Table 17. Regulator 1.2 V parameters

Characteristic	Symbol	Min	Typ	Max	Unit
Output Voltage ¹	V_{CAP}	—	1.22	—	V
Short Circuit Current ²	I_{SS}	—	600	—	mA
Short Circuit Tolerance (V_{CAP} shorted to ground)	T_{RSC}	—	—	30	Minutes

1. Value is after trim
2. Guaranteed by design

Table 18. Bandgap electrical specifications

Characteristic	Symbol	Min	Typ	Max	Unit
Reference Voltage (after trim)	V_{REF}	—	1.21	—	V

8.3 Clock modules

8.3.1 External clock operation timing

Parameters listed are guaranteed by design.

Table 19. External clock operation timing requirements

Characteristic	Symbol	Min	Typ	Max	Unit
Frequency of operation (external clock driver) ¹	f_{osc}	—	—	50	MHz
Clock pulse width ²	t_{PW}	8			ns
External clock input rise time ³	t_{rise}	—	—	1	ns
External clock input fall time ⁴	t_{fall}	—	—	1	ns
Input high voltage overdrive by an external clock	V_{ih}	$0.85V_{DD}$	—	—	V
Input low voltage overdrive by an external clock	V_{il}	—	—	$0.3V_{DD}$	V

1. See [Figure 1](#) for detail on using the recommended connection of an external clock driver.
2. The chip may not function if the high or low pulse width is smaller than 6.25 ns.
3. External clock input rise time is measured from 10% to 90%.
4. External clock input fall time is measured from 90% to 10%.

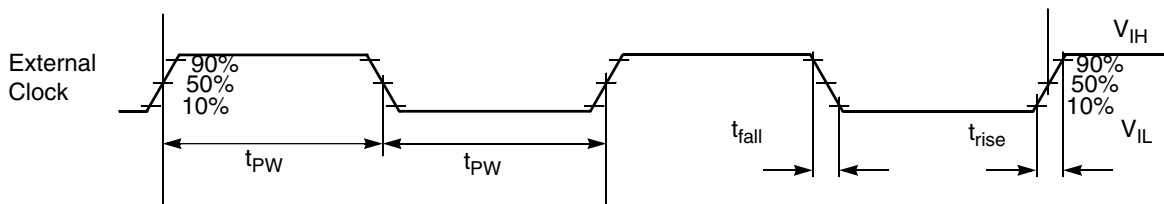

Note: The midpoint is $V_{IL} + (V_{IH} - V_{IL})/2$.

Figure 8. External clock timing

8.3.2 Phase-Locked Loop timing

Table 20. Phase-Locked Loop timing

Characteristic	Symbol	Min	Typ	Max	Unit
PLL input reference frequency ¹	f_{ref}	8	8	16	MHz
PLL output frequency ²	f_{op}	200	—	400	MHz
PLL lock time ³	t_{plls}	35.5		73.2	μ s
Allowed Duty Cycle of input reference	t_{dc}	40	50	60	%

1. An externally supplied reference clock should be as free as possible from any phase jitter for the PLL to work correctly. The PLL is optimized for 8 MHz input.
2. The frequency of the core system clock cannot exceed 100 MHz. If the NanoEdge PWM is available, the PLL output must be set to 400 MHz.
3. This is the time required *after the PLL is enabled* to ensure reliable operation.

8.3.3 External crystal or resonator requirement

Table 21. Crystal or resonator requirement

Characteristic	Symbol	Min	Typ	Max	Unit
Frequency of operation	f_{XOSC}	4	8	16	MHz

8.3.4 Relaxation Oscillator Timing

Table 22. Relaxation Oscillator Electrical Specifications

Characteristic		Symbol	Min	Typ	Max	Unit
8 MHz Output Frequency ¹						
Run Mode	0°C to 105°C		7.84	8	8.16	MHz
	-40°C to 105°C		7.76	8	8.24	MHz
	-40°C to 125°C		7.60	8	8.32	MHz
Standby Mode (IRC trimmed @ 8 MHz)	-40°C to 105°C		248	405	562	kHz
	-40°C to 125°C		198	405	702	kHz
8 MHz Frequency Variation over 25°C						
RUN Mode	0°C to 105°C			+/-1.5	+/-2	%
	-40°C to 105°C			+/-1.5	+/-3	%
	-40°C to 125°C			+/-1.5	-5 to +4	%
200 kHz Output Frequency ¹						
RUN Mode	-40°C to 105°C		194	200	206	kHz
	-40°C to 125°C		192	200	208	kHz
200 kHz Output Frequency Variation over 25°C						

Table continues on the next page...

Table 22. Relaxation Oscillator Electrical Specifications (continued)

Characteristic		Symbol	Min	Typ	Max	Unit
RUN Mode	0°C to 85°C			+/-1.5	+/-2	%
	-40°C to 105°C			+/-1.5	+/-3	%
	-40°C to 125°C			+/-1.5	+/-4	%
Stabilization Time	8 MHz output ²	tstab		0.12		µs
	200 kHz output ³			10		µs
Output Duty Cycle			48	50	52	%

1. Frequency after factory trim
2. Standby to run mode transition
3. Power down to run mode transition

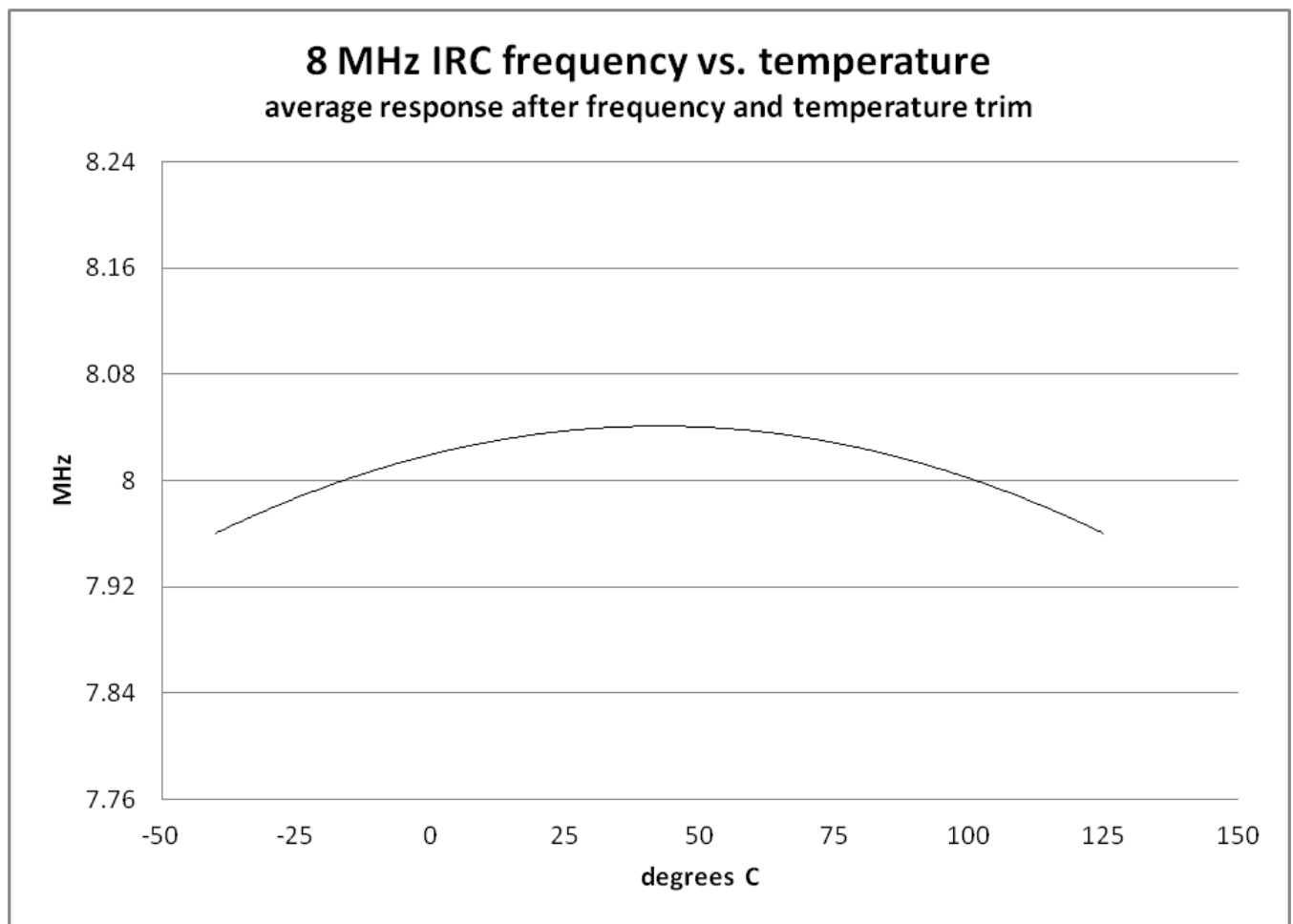

Figure 9. Relaxation Oscillator Temperature Variation (Typical) After Trim (Preliminary)

8.4 Memories and memory interfaces

8.4.1 Flash electrical specifications

This section describes the electrical characteristics of the flash memory module.

8.4.1.1 Flash timing specifications — program and erase

The following specifications represent the amount of time the internal charge pumps are active and do not include command overhead.

Table 23. NVM program/erase timing specifications

Symbol	Description	Min.	Typ.	Max.	Unit	Notes
$t_{\text{hvp gm4}}$	Longword Program high-voltage time	—	7.5	18	μs	—
t_{hversscr}	Sector Erase high-voltage time	—	13	113	ms	1
t_{hversall}	Erase All high-voltage time	—	52	452	ms	1

1. Maximum time based on expectations at cycling end-of-life.

8.4.1.2 Flash timing specifications — commands

Table 24. Flash command timing specifications

Symbol	Description	Min.	Typ.	Max.	Unit	Notes
t_{rd1sec1k}	Read 1s Section execution time (flash sector)	—	—	60	μs	1
t_{pgmchk}	Program Check execution time	—	—	45	μs	1
t_{rdsrc}	Read Resource execution time	—	—	30	μs	1
t_{pgm4}	Program Longword execution time	—	65	145	μs	—
t_{ersscr}	Erase Flash Sector execution time	—	14	114	ms	2
t_{rd1all}	Read 1s All Blocks execution time	—	—	0.9	ms	1
t_{rdonce}	Read Once execution time	—	—	25	μs	1
t_{pgmonce}	Program Once execution time	—	65	—	μs	—
t_{ersall}	Erase All Blocks execution time	—	70	575	ms	2
t_{vfykey}	Verify Backdoor Access Key execution time	—	—	30	μs	1

1. Assumes 25 MHz flash clock frequency.
2. Maximum times for erase parameters based on expectations at cycling end-of-life.

8.4.1.3 Flash high voltage current behaviors

Table 25. Flash high voltage current behaviors

Symbol	Description	Min.	Typ.	Max.	Unit
$I_{\text{DD_PGM}}$	Average current adder during high voltage flash programming operation	—	2.5	6.0	mA

Table continues on the next page...

Table 25. Flash high voltage current behaviors (continued)

Symbol	Description	Min.	Typ.	Max.	Unit
I _{DD_ERS}	Average current adder during high voltage flash erase operation	—	1.5	4.0	mA

8.4.1.4 Reliability specifications

Table 26. NVM reliability specifications

Symbol	Description	Min.	Typ. ¹	Max.	Unit	Notes
Program Flash						
t _{nvmp10k}	Data retention after up to 10 K cycles	5	50	—	years	—
t _{nvmp1k}	Data retention after up to 1 K cycles	20	100	—	years	—
n _{nvmp}	Cycling endurance	10 K	50 K	—	cycles	2

1. Typical data retention values are based on measured response accelerated at high temperature and derated to a constant 25 °C use profile. Engineering Bulletin EB618 does not apply to this technology. Typical endurance defined in Engineering Bulletin EB619.
2. Cycling endurance represents number of program/erase cycles at $-40\text{ °C} \leq T_j \leq 125\text{ °C}$.

8.5 Analog

8.5.1 12-bit Cyclic Analog-to-Digital Converter (ADC) Parameters

Table 27. 12-bit ADC Electrical Specifications

Characteristic	Symbol	Min	Typ	Max	Unit
Recommended Operating Conditions					
Supply Voltage ¹	V _{DDA}	3	3.3	3.6	V
V _{REFH} (in external reference mode)	V _{REFH}	V _{DDA} -0.6		V _{DDA}	V
ADC Conversion Clock ²	f _{ADCCLK}	0.1		10	MHz
Conversion Range ³	R _{AD}			V _{REFH} - V _{REFL}	V
Fully Differential		-(V _{REFH} - V _{REFL})		V _{REFH}	
Single Ended/Unipolar		V _{REFL}			
Input Voltage Range (per input) ⁴	V _{ADIN}			V _{REFH}	V
External Reference		V _{REFL}		V _{DDA}	
Internal Reference		0			
Timing and Power					
Conversion Time ⁵	t _{ADC}		8		ADC Clock Cycles
ADC Power-Up Time (from adc_pdn)	t _{ADPU}		13		ADC Clock Cycles

Table continues on the next page...

Table 27. 12-bit ADC Electrical Specifications (continued)

Characteristic	Symbol	Min	Typ	Max	Unit
ADC RUN Current (per ADC block)	I_{ADRUN}		1.8		mA
ADC Powerdown Current (adc_pdn enabled)	$I_{ADPWRDWN}$		0.1		μ A
V_{REFH} Current (in external mode)	I_{VREFH}		190	225	μ A
Accuracy (DC or Absolute)					
Integral non-Linearity ⁶	INL		+/- 1.5	+/- 2.2	LSB ⁷
Differential non-Linearity ⁶	DNL		+/- 0.5	+/- 0.8	LSB ⁷
Monotonicity		GUARANTEED			
Offset ⁸	V_{OFFSET}		+/- 8		mV
Fully Differential			+/- 12		
Single Ended/Unipolar					
Gain Error	E_{GAIN}		0.996 to 1.004	0.990 to 1.010	
AC Specifications⁹					
Signal to Noise Ratio	SNR		66		dB
Total Harmonic Distortion	THD		75		dB
Spurious Free Dynamic Range	SFDR		77		dB
Signal to Noise plus Distortion	SINAD		66		dB
Effective Number of Bits	ENOB		—		bits
Gain = 1x (Fully Differential/Unipolar)			10.6		
Gain = 2x (Fully Differential/Unipolar)			—		
Gain = 4x (Fully Differential/Unipolar)			10.3		
Gain = 1x (Single Ended)			10.6		
Gain = 2x (Single Ended)			10.4		
Gain = 4x (Single Ended)			10.2		
Variation across channels ¹⁰			0.1		
ADC Inputs					
Input Leakage Current	I_{IN}		1		nA
Temperature sensor slope	T_{SLOPE}		1.7		mV/°C
Temperature sensor voltage at 25 °C	V_{TEMP25}		0.82		V
Disturbance					
Input Injection Current ¹¹	I_{INJ}			+/-3	mA
Channel to Channel Crosstalk ¹²	ISOXTLK		-82		dB
Memory Crosstalk ¹³	MEMXTLK		-71		dB
Input Capacitance	C_{ADI}		4.8		pF
Sampling Capacitor					

1. The ADC functions up to $V_{DDA} = 2.7$ V. When V_{DDA} is below 3.0 V, ADC specifications are not guaranteed
2. ADC clock duty cycle is 45% ~ 55%
3. Conversion range is defined for x1 gain setting. For x2 and x4 the range is 1/2 and 1/4, respectively.
4. In unipolar mode, positive input must be ensured to be always greater than negative input.
5. First conversion takes 10 clock cycles.
6. INL/DNL is measured from $V_{IN} = V_{REFL}$ to $V_{IN} = V_{REFH}$ using Histogram method at x1 gain setting

System modules

7. Least Significant Bit = 0.806 mV at 3.3 V V_{DDA} , x1 gain Setting
8. Offset measured at 2048 code
9. Measured converting a 1 kHz input full scale sine wave
10. When code runs from internal RAM
11. The current that can be injected into or sourced from an unselected ADC input without affecting the performance of the ADC
12. Any off-channel with 50 kHz full-scale input to the channel being sampled with DC input (isolation crosstalk)
13. From a previously sampled channel with 50 kHz full-scale input to the channel being sampled with DC input (memory crosstalk).

8.5.1.1 Equivalent circuit for ADC inputs

The following figure shows the ADC input circuit during sample and hold. S1 and S2 are always opened/closed at non-overlapping phases, and both S1 and S2 are dependent on the ADC clock frequency. The following equation gives equivalent input impedance when the input is selected.

$$\frac{1}{(\text{ADC ClockRate}) \times 4.8 \times 10^{-12}} + 100 \text{ ohm} + 50 \text{ ohm}$$

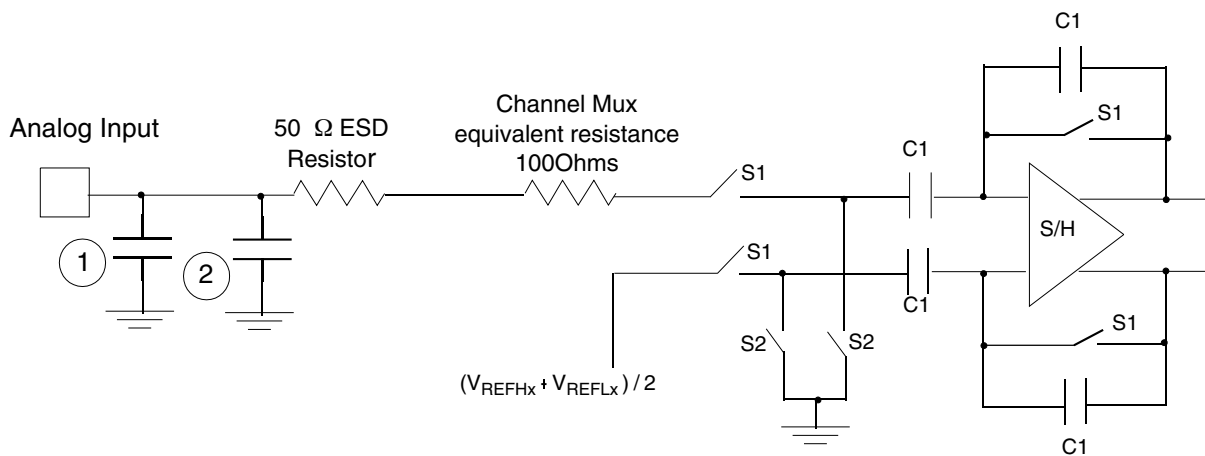

1. Parasitic capacitance due to package, pin-to-pin and pin-to-package base coupling = 1.8pF
2. Parasitic capacitance due to the chip bond pad, ESD protection devices and signal routing = 2.04pF
3. S1 and S2 switch phases are non-overlapping and depend on the ADC clock frequency

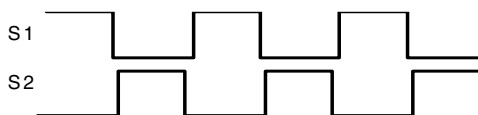

Figure 10. Equivalent circuit for A/D loading

8.5.2 12-bit Digital-to-Analog Converter (DAC) parameters

Table 28. DAC parameters

Parameter	Conditions/Comments	Symbol	Min	Typ	Max	Unit
DC Specifications						
Resolution			12	12	12	bits
Settling time ¹	At output load RLD = 3 k Ω CLD = 400 pF		—	1		μ s
Power-up time	Time from release of PWRDWN signal until DACOUT signal is valid	t_{DAPU}	—	—	11	μ s
Accuracy						
Integral non-linearity ²	Range of input digital words: 410 to 3891 (\$19A - \$F33) 5% to 95% of full range	INL	—	+/- 3	+/- 4	LSB ³
Differential non-linearity ²	Range of input digital words: 410 to 3891 (\$19A - \$F33) 5% to 95% of full range	DNL	—	+/- 0.8	+/- 0.9	LSB ³
Monotonicity	> 6 sigma monotonicity, < 3.4 ppm non-monotonicity		guaranteed			—
Offset error ²	Range of input digital words: 410 to 3891 (\$19A - \$F33) 5% to 95% of full range	V_{OFFSET}	—	+/- 25	+/- 43	mV
Gain error ²	Range of input digital words: 410 to 3891 (\$19A - \$F33) 5% to 95% of full range	E_{GAIN}	—	+/- 0.5	+/- 1.5	%
DAC Output						
Output voltage range	Within 40 mV of either V_{SSA} or V_{DDA}	V_{OUT}	$V_{SSA} + 0.04$ V	—	$V_{DDA} - 0.04$ V	V
AC Specifications						
Signal-to-noise ratio		SNR	—	85	—	dB
Spurious free dynamic range		SFDR	—	-72	—	dB
Effective number of bits		ENOB	—	11	—	bits

1. Settling time is swing range from V_{SSA} to V_{DDA}
2. No guaranteed specification within 5% of V_{DDA} or V_{SSA}
3. LSB = 0.806 mV

8.5.3 CMP and 6-bit DAC electrical specifications

Table 29. Comparator and 6-bit DAC electrical specifications

Symbol	Description	Min.	Typ.	Max.	Unit
V_{DD}	Supply voltage	2.7	—	3.6	V
I_{DDHS}	Supply current, High-speed mode (EN=1, PMODE=1)	—	300	—	μ A
I_{DLS}	Supply current, low-speed mode (EN=1, PMODE=0)	—	36	—	μ A
V_{AIN}	Analog input voltage	V_{SS}	—	V_{DD}	V
V_{AIO}	Analog input offset voltage	—	—	20	mV
V_H	Analog comparator hysteresis <ul style="list-style-type: none"> • CR0[HYSTCTR] = 00¹ • CR0[HYSTCTR] = 01 • CR0[HYSTCTR] = 10² • CR0[HYSTCTR] = 11² 	—	5	13	mV
		—	25	48	mV
		—	55	105	mV
		—	80	148	mV
V_{CMPOH}	Output high	$V_{DD} - 0.5$	—	—	V
V_{CMPOI}	Output low	—	—	0.5	V
t_{DHS}	Propagation delay, high-speed mode (EN=1, PMODE=1)	—	25	50	ns
t_{DLS}	Propagation delay, low-speed mode (EN=1, PMODE=0) ³	—	60	200	ns
	Analog comparator initialization delay ⁴	—	40	—	μ s
I_{DAC6b}	6-bit DAC current adder (enabled)	—	7	—	μ A
	6-bit DAC reference inputs, Vin1 and Vin2 There are two reference input options selectable (via VRSEL control bit). The reference options must fall within this range.	V_{DDA}	—	V_{DD}	V
INL	6-bit DAC integral non-linearity	-0.5	—	0.5	LSB ⁵
DNL	6-bit DAC differential non-linearity	-0.3	—	0.3	LSB

1. Measured with input voltage range limited to 0 to V_{DD}
2. Measured with input voltage range limited to $0.7 \leq V_{in} \leq V_{DD} - 0.8$
3. Input voltage range: $0.1V_{DD} \leq V_{in} \leq 0.9V_{DD}$, step = ± 100 mV, across all temperature. Does not include PCB and PAD delay.
4. Comparator initialization delay is defined as the time between software writes to change control inputs (Writes to DACEN, VRSEL, PSEL, MSEL, VOSEL) and the comparator output settling to a stable level.
5. 1 LSB = $V_{reference}/64$

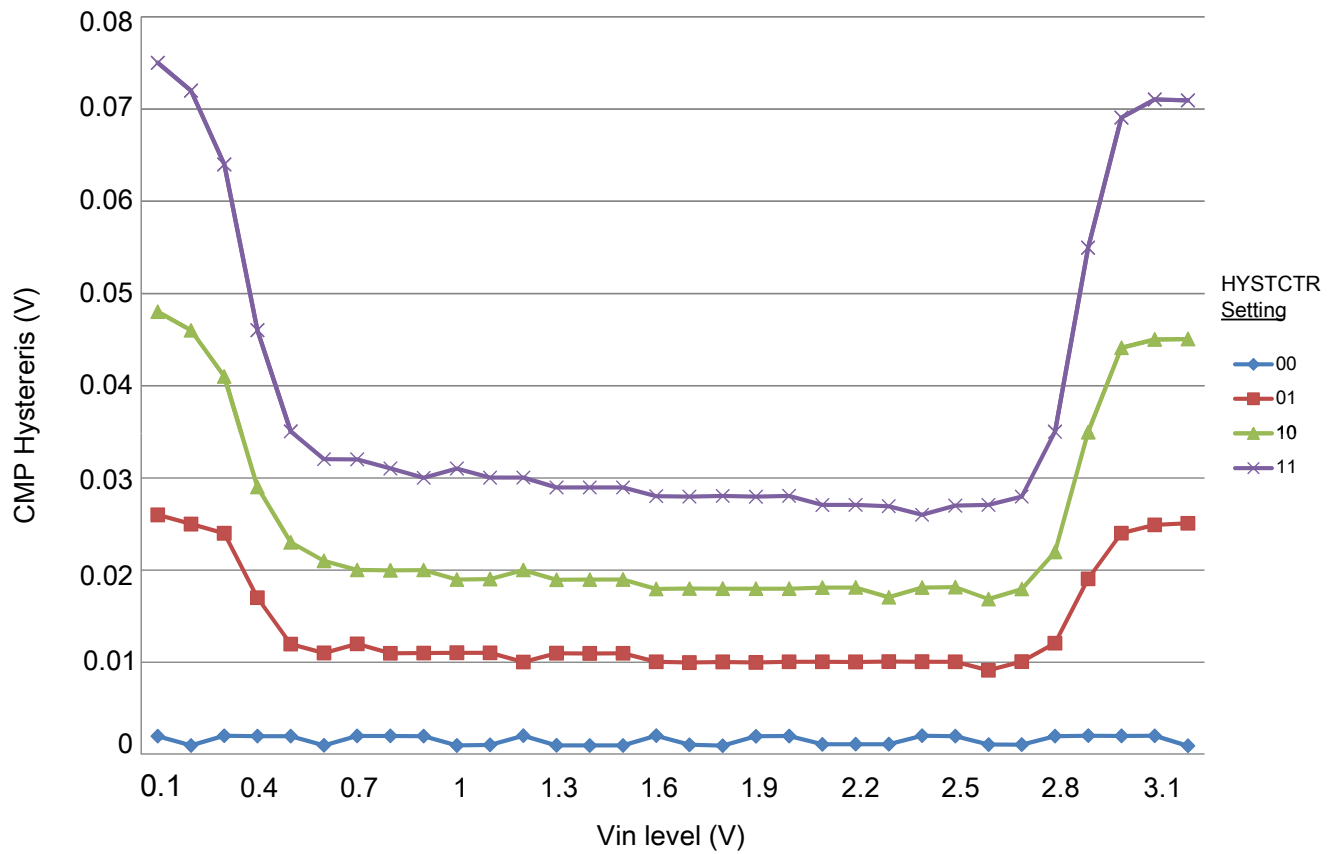

Figure 11. Typical hysteresis vs. Vin level ($V_{DD} = 3.3\text{ V}$, $PMODE = 0$)

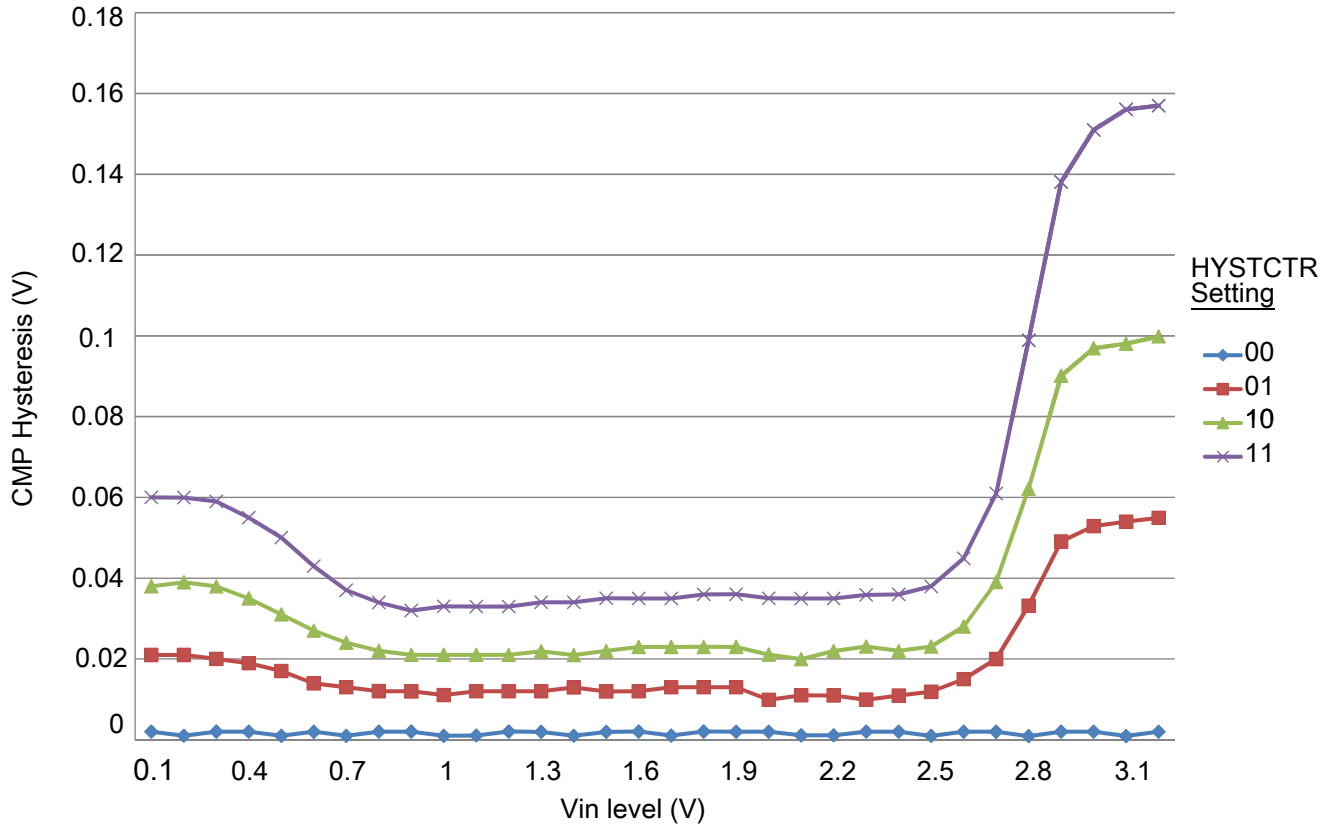

Figure 12. Typical hysteresis vs. Vin level ($V_{DD} = 3.3\text{ V}$, $P\text{MODE} = 1$)

8.6 PWMs and timers

8.6.1 Enhanced NanoEdge PWM characteristics

Table 30. NanoEdge PWM timing parameters

Characteristic	Symbol	Min	Typ	Max	Unit
PWM clock frequency			100		MHz
NanoEdge Placement (NEP) Step Size ^{1,2}	pwmp		312		ps
Delay for fault input activating to PWM output deactivated		1			ns
Power-up Time ³	t_{pu}		25		μs

1. Reference IPbus clock of 100 MHz in NanoEdge Placement mode.
2. Temperature and voltage variations do not affect NanoEdge Placement step size.
3. Powerdown to NanoEdge mode transition.

8.6.2 Quad Timer timing

Parameters listed are guaranteed by design.

Table 31. Timer timing

Characteristic	Symbol	Min ¹	Max	Unit	See Figure
Timer input period	P _{IN}	2T + 6	—	ns	Figure 13
Timer input high/low period	P _{INHL}	1T + 3	—	ns	Figure 13
Timer output period	P _{OUT}	2T-2	—	ns	Figure 13
Timer output high/low period	P _{OUTHL}	1T-2	—	ns	Figure 13

1. T = clock cycle. For 100 MHz operation, T = 10 ns.

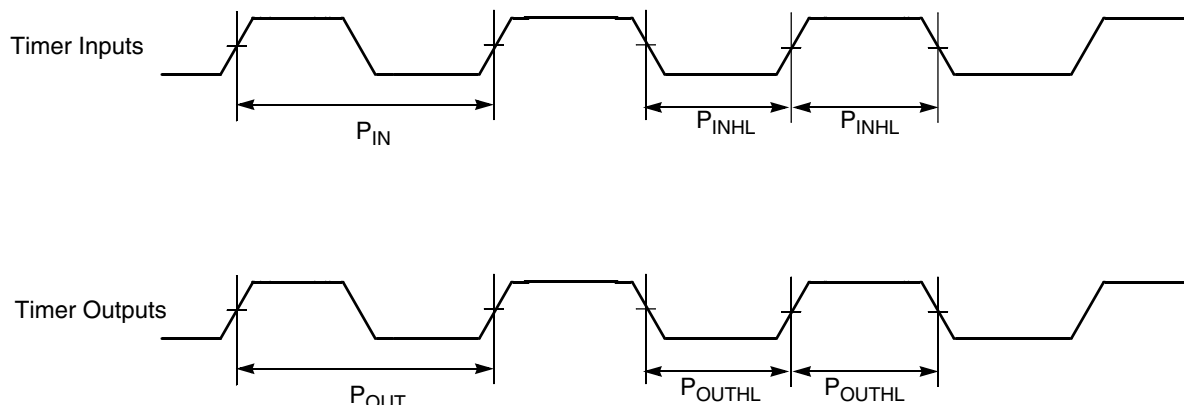

Figure 13. Timer timing

8.7 Communication interfaces

8.7.1 Queued Serial Peripheral Interface (SPI) timing

Parameters listed are guaranteed by design.

Table 32. SPI timing

Characteristic	Symbol	Min	Max	Unit	See Figure
Cycle time	t _C	60	—	ns	Figure 14
		60	—	ns	Figure 15
					ns
Enable lead time	t _{ELD}	—	—	ns	Figure 17
		20	—	ns	
					ns
Enable lag time	t _{ELG}	—	—	ns	Figure 17
		20	—	ns	
					ns

Table continues on the next page...

Table 32. SPI timing (continued)

Characteristic	Symbol	Min	Max	Unit	See Figure
Clock (SCK) high time	t_{CH}		—	ns	Figure 14
Master			—	ns	Figure 15
Slave					Figure 16 Figure 17
Clock (SCK) low time	t_{CL}	28	—	ns	Figure 17
Master		28	—	ns	
Slave					
Data set-up time required for inputs	t_{DS}	20	—	ns	Figure 14
Master		1	—	ns	Figure 15
Slave					Figure 16 Figure 17
Data hold time required for inputs	t_{DH}	1	—	ns	Figure 14
Master		3	—	ns	Figure 15
Slave					Figure 16 Figure 17
Access time (time to data active from high-impedance state)	t_A	5	—	ns	Figure 17
Slave					
Disable time (hold time to high-impedance state)	t_D	5	—	ns	Figure 17
Slave					
Data valid for outputs	t_{DV}	—		ns	Figure 14
Master		—		ns	Figure 15
Slave (after enable edge)					Figure 16 Figure 17
Data invalid	t_{DI}	0	—	ns	Figure 14
Master		0	—	ns	Figure 15
Slave					Figure 16 Figure 17
Rise time	t_R	—	1	ns	Figure 14
Master		—	1	ns	Figure 15
Slave					Figure 16 Figure 17
Fall time	t_F	—	1	ns	Figure 14
Master		—	1	ns	Figure 15
Slave					Figure 16 Figure 17

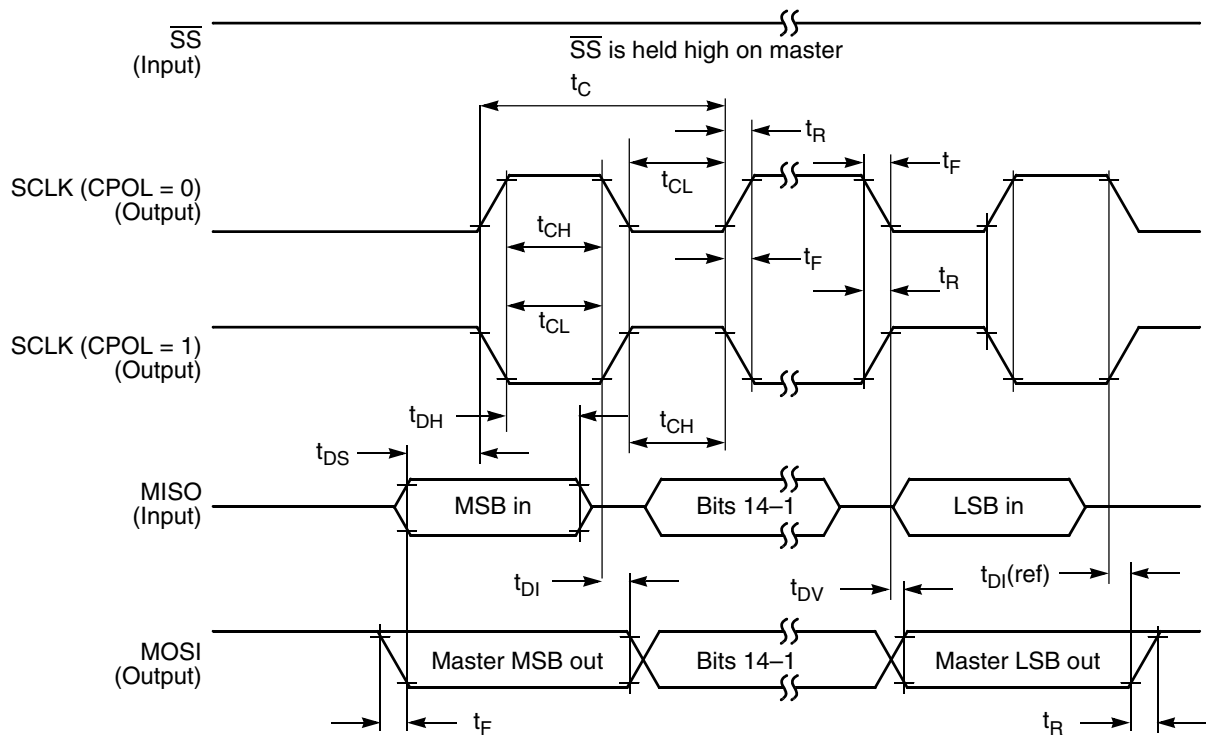

Figure 14. SPI master timing (CPHA = 0)

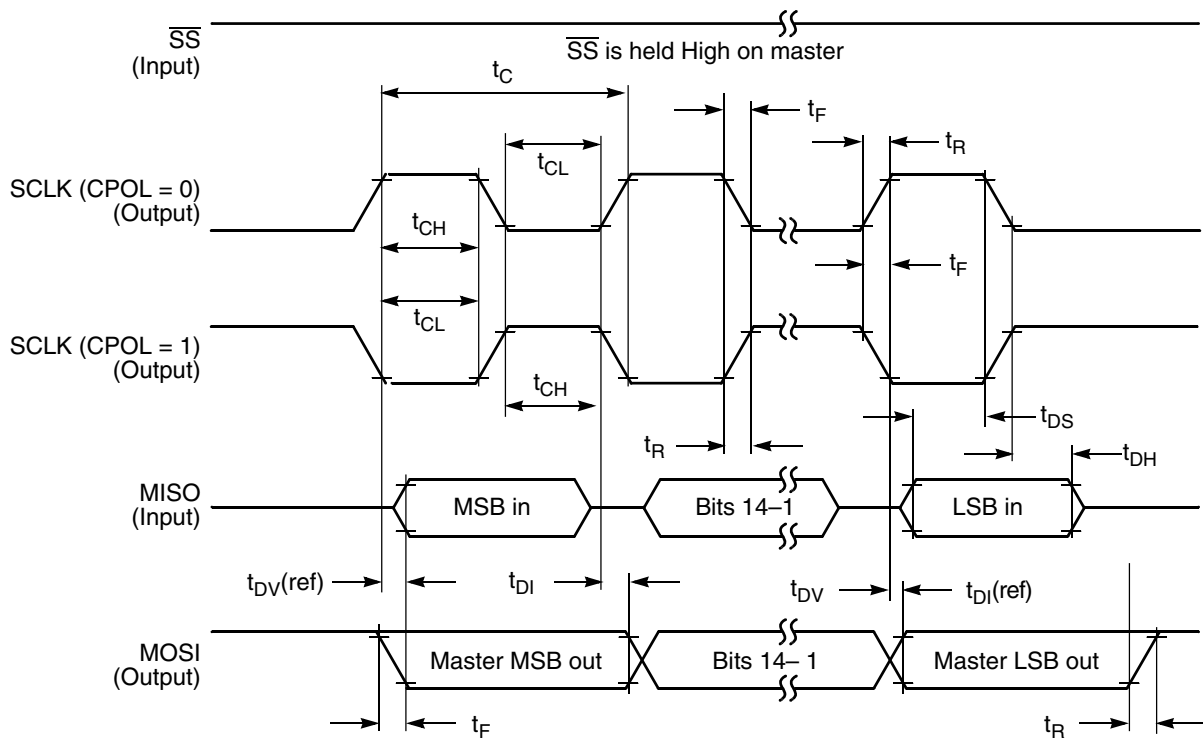

Figure 15. SPI master timing (CPHA = 1)

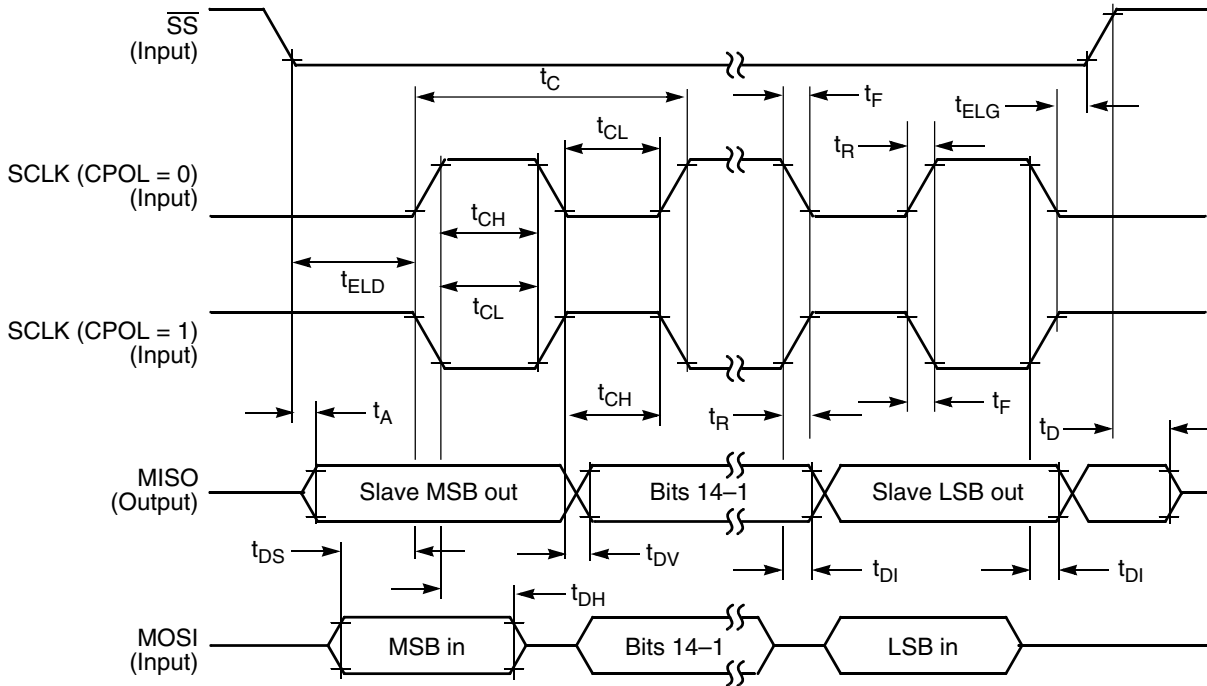

Figure 16. SPI slave timing (CPHA = 0)

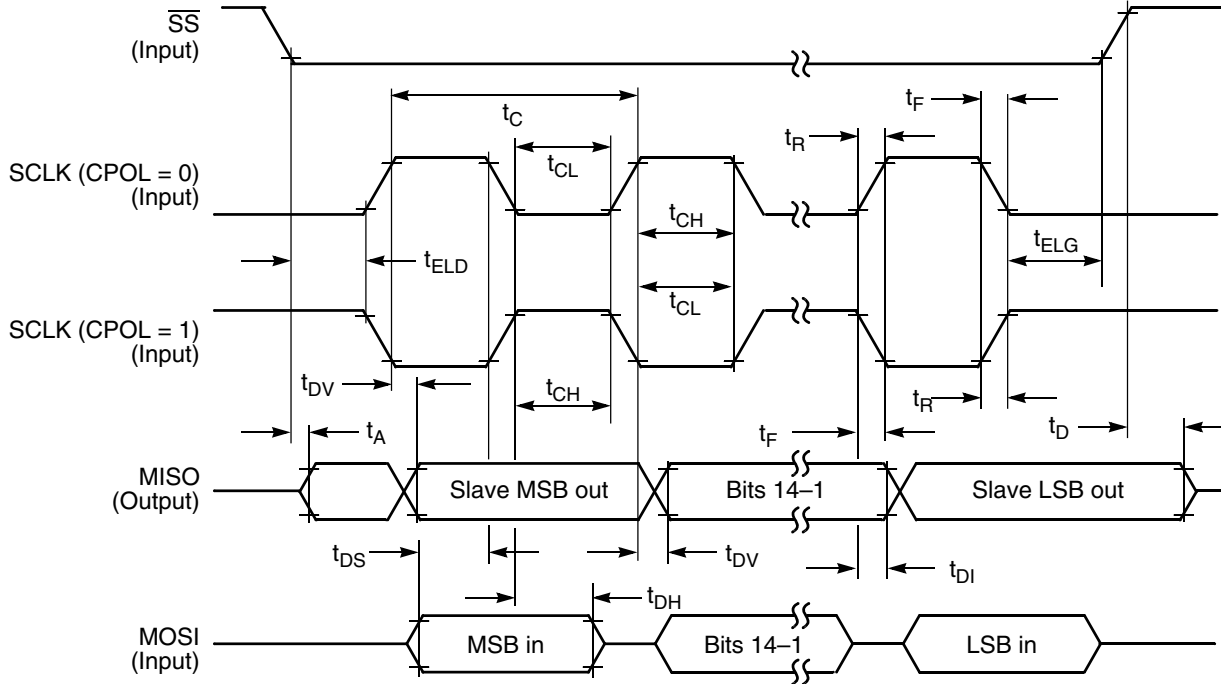

Figure 17. SPI slave timing (CPHA = 1)

8.7.2 Queued Serial Communication Interface (SCI) timing

Parameters listed are guaranteed by design.

Table 33. SCI timing

Characteristic	Symbol	Min	Max	Unit	See Figure
Baud rate ¹	BR	—	($f_{MAX}/16$)	Mbit/s	—
RXD pulse width	RXD _{PW}	0.965/BR	1.04/BR	μs	Figure 18
TXD pulse width	TXD _{PW}	0.965/BR	1.04/BR	μs	Figure 19
LIN Slave Mode					
Deviation of slave node clock from nominal clock rate before synchronization	F _{TOL_UNSYNCH}	-14	14	%	—
Deviation of slave node clock relative to the master node clock after synchronization	F _{TOL_SYNCH}	-2	2	%	—
Minimum break character length	T _{BREAK}	13	—	Master node bit periods	—
		11	—	Slave node bit periods	—

1. f_{MAX} is the frequency of operation of the SCI clock in MHz, which can be selected as the bus clock (max.50 MHz depending on part number) or 2x bus clock (max. 100 MHz) for the devices.

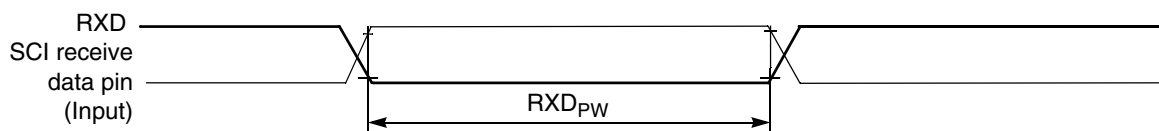

Figure 18. RXD pulse width

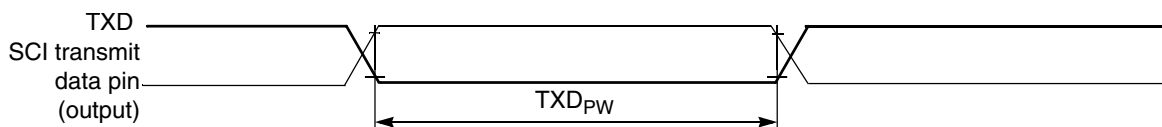

Figure 19. TXD pulse width

8.7.3 Modular/Scalable Controller Area Network (MSCAN)

Table 34. MSCAN Timing Parameters

Characteristic	Symbol	Min	Max	Unit
Baud Rate	BR _{CAN}	—	1	Mbit/s
CAN Wakeup dominant pulse filtered	T _{WAKEUP}	—	1.5	μs
CAN Wakeup dominant pulse pass	T _{WAKEUP}	5	—	μs

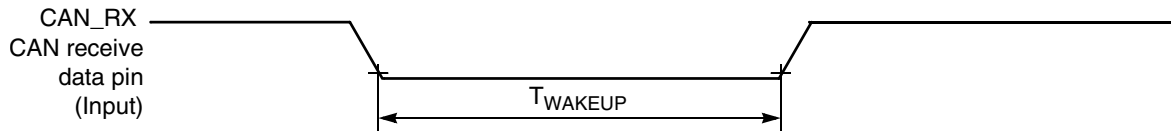

Figure 20. Bus Wake-up Detection

NOTE

CAN wakeup is not supported when ROOSC_8M is in standby mode.

8.7.4 Inter-Integrated Circuit Interface (I²C) timing

Table 35. I²C timing

Characteristic	Symbol	Standard Mode		Fast Mode		Unit
		Minimum	Maximum	Minimum	Maximum	
SCL Clock Frequency	f _{SCL}	0	100	0	400	kHz
Hold time (repeated) START condition. After this period, the first clock pulse is generated.	t _{HD; STA}	4	—	0.6	—	μs
LOW period of the SCL clock	t _{LOW}	4.7	—	1.3	—	μs
HIGH period of the SCL clock	t _{HIGH}	4	—	0.6	—	μs
Set-up time for a repeated START condition	t _{SU; STA}	4.7	—	0.6	—	μs
Data hold time for I ² C bus devices	t _{HD; DAT}	0 ¹	3.45 ²	0 ³	0.9 ¹	μs
Data set-up time	t _{SU; DAT}	250 ⁴	—	100 ^{2,5}	—	ns
Rise time of SDA and SCL signals	t _r	—	1000	20 + 0.1C _b ⁶	300	ns
Fall time of SDA and SCL signals	t _f	—	300	20 + 0.1C _b ⁵	300	ns
Set-up time for STOP condition	t _{SU; STO}	4	—	0.6	—	μs
Bus free time between STOP and START condition	t _{BUF}	4.7	—	1.3	—	μs
Pulse width of spikes that must be suppressed by the input filter	t _{SP}	N/A	N/A	0	50	ns

1. The master mode I²C deasserts ACK of an address byte simultaneously with the falling edge of SCL. If no slaves acknowledge this address byte, then a negative hold time can result, depending on the edge rates of the SDA and SCL lines.
2. The maximum t_{HD; DAT} must be met only if the device does not stretch the LOW period (t_{LOW}) of the SCL signal.
3. Input signal Slew = 10 ns and Output Load = 50 pF.
4. Set-up time in slave-transmitter mode is 1 IP Bus clock period, if the TX FIFO is empty.
5. A Fast mode I²C bus device can be used in a Standard mode I²C bus system, but the requirement t_{SU; DAT} ≥ 250 ns must then be met. This is automatically the case if the device does not stretch the LOW period of the SCL signal. If such a device does stretch the LOW period of the SCL signal, then it must output the next data bit to the SDA line t_{rmax} + t_{SU; DAT} = 1000 + 250 = 1250 ns (according to the Standard mode I²C bus specification) before the SCL line is released.
6. C_b = total capacitance of the one bus line in pF.

$R_{\Theta JA}$ = Package junction-to-ambient thermal resistance ($^{\circ}\text{C}/\text{W}$)

$R_{\Theta JC}$ = Package junction-to-case thermal resistance ($^{\circ}\text{C}/\text{W}$)

$R_{\Theta CA}$ = Package case-to-ambient thermal resistance ($^{\circ}\text{C}/\text{W}$)

$R_{\Theta JC}$ is device related and cannot be adjusted. You control the thermal environment to change the case to ambient thermal resistance, $R_{\Theta CA}$. For instance, you can change the size of the heat sink, the air flow around the device, the interface material, the mounting arrangement on printed circuit board, or change the thermal dissipation on the printed circuit board surrounding the device.

To determine the junction temperature of the device in the application when heat sinks are not used, the thermal characterization parameter (YJT) can be used to determine the junction temperature with a measurement of the temperature at the top center of the package case using the following equation:

$$T_J = T_T + (\Psi_{JT} \times P_D)$$

Where,

T_T = Thermocouple temperature on top of package ($^{\circ}\text{C}/\text{W}$)

Ψ_{JT} = thermal characterization parameter ($^{\circ}\text{C}/\text{W}$)

P_D = Power dissipation in package (W)

The thermal characterization parameter is measured per JESD51–2 specification using a 40-gauge type T thermocouple epoxied to the top center of the package case. The thermocouple should be positioned so that the thermocouple junction rests on the package. A small amount of epoxy is placed over the thermocouple junction and over about 1 mm of wire extending from the junction. The thermocouple wire is placed flat against the package case to avoid measurement errors caused by cooling effects of the thermocouple wire.

To determine the junction temperature of the device in the application when heat sinks are used, the junction temperature is determined from a thermocouple inserted at the interface between the case of the package and the interface material. A clearance slot or hole is normally required in the heat sink. Minimizing the size of the clearance is important to minimize the change in thermal performance caused by removing part of the thermal interface to the heat sink. Because of the experimental difficulties with this technique, many engineers measure the heat sink temperature and then back-calculate the case temperature using a separate measurement of the thermal resistance of the interface. From this case temperature, the junction temperature is determined from the junction-to-case thermal resistance.

9.2 Electrical design considerations

CAUTION

This device contains protective circuitry to guard against damage due to high static voltage or electrical fields. However, take normal precautions to avoid application of any voltages higher than maximum-rated voltages to this high-impedance circuit. Reliability of operation is enhanced if unused inputs are tied to an appropriate voltage level.

Use the following list of considerations to assure correct operation of the device:

- Provide a low-impedance path from the board power supply to each V_{DD} pin on the device and from the board ground to each V_{SS} (GND) pin.
- The minimum bypass requirement is to place 0.01–0.1 μF capacitors positioned as near as possible to the package supply pins. The recommended bypass configuration is to place one bypass capacitor on each of the V_{DD}/V_{SS} pairs, including V_{DDA}/V_{SSA} . Ceramic and tantalum capacitors tend to provide better tolerances.
- Ensure that capacitor leads and associated printed circuit traces that connect to the chip V_{DD} and V_{SS} (GND) pins are as short as possible.
- Bypass the V_{DD} and V_{SS} with approximately 100 μF , plus the number of 0.1 μF ceramic capacitors.
- PCB trace lengths should be minimal for high-frequency signals.
- Consider all device loads as well as parasitic capacitance due to PCB traces when calculating capacitance. This is especially critical in systems with higher capacitive loads that could create higher transient currents in the V_{DD} and V_{SS} circuits.
- Take special care to minimize noise levels on the V_{REF} , V_{DDA} , and V_{SSA} pins.
- Using separate power planes for V_{DD} and V_{DDA} and separate ground planes for V_{SS} and V_{SSA} are recommended. Connect the separate analog and digital power and ground planes as near as possible to power supply outputs. If an analog circuit and digital circuit are powered by the same power supply, then connect a small inductor or ferrite bead in serial with V_{DDA} . Traces of V_{SS} and V_{SSA} should be shorted together.
- Physically separate analog components from noisy digital components by ground planes. Do not place an analog trace in parallel with digital traces. Place an analog ground trace around an analog signal trace to isolate it from digital traces.
- Because the flash memory is programmed through the JTAG/EOnCE port, SPI, SCI, or I²C, the designer should provide an interface to this port if in-circuit flash programming is desired.
- If desired, connect an external RC circuit to the $\overline{\text{RESET}}$ pin. The resistor value should be in the range of 4.7 k Ω –10 k Ω ; the capacitor value should be in the range of 0.22 μF –4.7 μF .

- Configuring the $\overline{\text{RESET}}$ pin to GPIO output in normal operation in a high-noise environment may help to improve the performance of noise transient immunity.
- Add a 2.2 k Ω external pullup on the TMS pin of the JTAG port to keep EOnCE in a restate during normal operation if JTAG converter is not present.
- During reset and after reset but before I/O initialization, all I/O pins are at tri-state.
- To eliminate PCB trace impedance effect, each ADC input should have a no less than 33 pF 10 Ω RC filter.

9.3 Power-on Reset design considerations

9.3.1 Improper power-up sequence between VDD/VSS and VDDA/VSSA:

It is recommended that VDD be kept within 100 mV of VDDA at all times, including power ramp-up and ramp-down. Failure to keep VDDA within 100 mV of VDDA may cause a leakage current through the substrate, between the VDD and VDDA pad cells. This leakage current could prevent operation of the device after it powers up. The voltage difference between VDD and VDDA must be limited to below 0.3 V at all times, to avoid permanent damage to the part (See [Table 5](#)). Also see [Table 6](#).

9.3.2 Unnecessary protection circuit:

In many circuit designs, it is a general practice to add external clamping diodes on each analog input pin; see diode D1 and D2 in [Figure 22](#), to prevent the surge voltage from damaging the analog input.

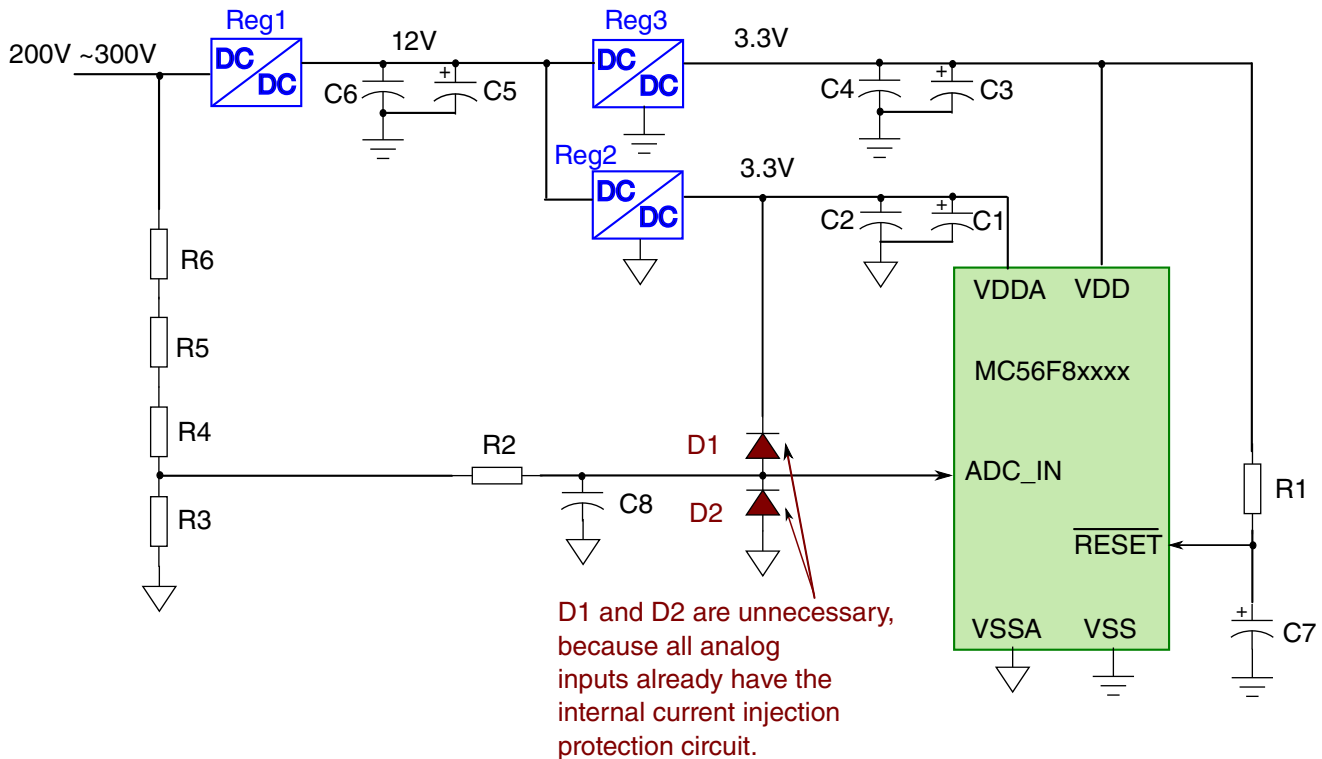

Figure 22. Protection Circuit Example

MC56F8xxx DSC uses the 5V tolerance I/O. When the pin is configured to digital input, it can accept 5V input. See [Table 5](#). When the pin is configured to analog input, the internal integrated current injection protection circuit is enabled. The current injection protection circuit performs the same functions as external clamp diode D1 and D2 in [Figure 22](#). As long as the source or sink current for each analog pin is less than 3 mA, then there is no damage to the device. See [Table 27](#). Therefore, D1 and D2 clamping diodes are **not** recommended to be used.

9.3.3 Heavy capacitive load on power supply output:

In some applications, the low cost DC/DC converter may not regulate the output voltage well before it reaches the regulation point, which is roughly around 2.5V to 2.7V. However, the MC56F8xxx DSC will exit power-on reset at around 2.3V. If the initialization code enables the PLL to run the DSC at full speed right after reset, then the high current will be pulled by DSC from the supply, which can cause the supply voltage to drop below the operation voltage; see the captured graph ([Figure 23](#)). This can cause the DSC fail to start up.

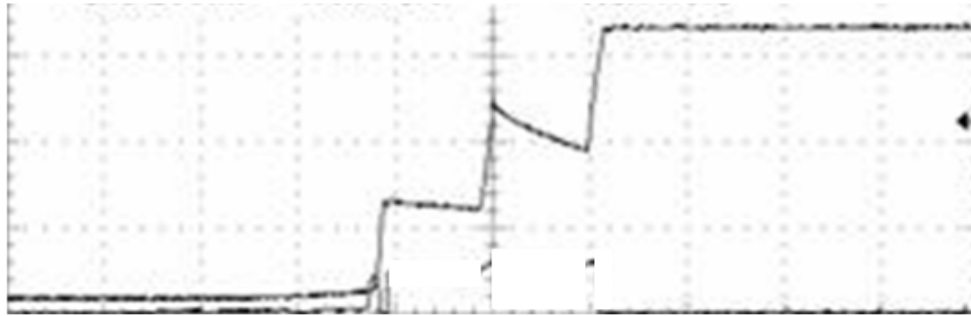

Figure 23. Supply Voltage Drop

A recommended initialization sequence during power-up is:

1. After POR is released, run a few hundred NOP instructions from the internal relaxation oscillator; this gives time for the supply voltage to stabilize.
2. Configure the peripherals (except the ADC) to the desired settings; the ADC should stay in low power mode.
3. Power up the PLL.
4. After the PLL locks, switch the clock from PLL prescale to postscale.
5. Configure the ADC.

10 Obtaining package dimensions

Package dimensions are provided in package drawings.

To find a package drawing, go to nxp.com and perform a keyword search for the drawing's document number:

Drawing for package	Document number to be used
32LQFP	98ASH70029A
32QFN	98ASA00473D
48-pin LQFP	98ASH00962A
64-pin LQFP	98ASS23234W

11 Pinout

11.1 Signal Multiplexing and Pin Assignments

The following table shows the signals available on each pin and the locations of these pins on the devices supported by this document. The SIM's GPS registers are responsible for selecting which ALT functionality is available on most pins.

NOTE

- The RESETB pin is a 3.3 V pin only.
- If the GPIOC1 pin is used as GPIO, the XOSC should be powered down.
- Not all CMPD pins are available on 48 LQFP, 32 LQFP, and 32 QFN packages.
- QSPI signals—including MISO1, MOSI1, SCLK1, and SSO_B—are not available on the 48 LQFP, 32 LQFP, and 32 QFN packages.

64 LQFP	48 LQFP	32 LQFP	Pin Name	Default	ALT0	ALT1	ALT2	ALT3
1	1	1	TCK	TCK	GPIOD2			
2	2	2	RESETB	RESETB	GPIOD4			
3	3	—	GPIOC0	GPIOC0	EXTAL	CLKIN0		
4	4	—	GPIOC1	GPIOC1	XTAL			
5	5	3	GPIOC2	GPIOC2	TXD0	XB_OUT11	XB_IN2	CLKO0
6	—	—	GPIOF8	GPIOF8	RXD0	XB_OUT10	CMPD_O	PWM_2X
7	6	4	GPIOC3	GPIOC3	TA0	CMPA_O	RXD0	CLKIN1
8	7	5	GPIOC4	GPIOC4	TA1	CMPB_O	XB_IN6	EWM_OUT_B
9	—	—	GPIOA7	GPIOA7	ANA7&CMPD_IN3			
10	—	—	GPIOA6	GPIOA6	ANA6&CMPD_IN2			
11	—	—	GPIOA5	GPIOA5	ANA5&CMPD_IN1			
12	8	—	GPIOA4	GPIOA4	ANA4&CMPD_IN0			
13	9	6	GPIOA0	GPIOA0	ANA0&CMPA_IN3	CMPC_O		
14	10	7	GPIOA1	GPIOA1	ANA1&CMPA_IN0			
15	11	8	GPIOA2	GPIOA2	ANA2&VREFHA&CMPA_IN1			
16	12	—	GPIOA3	GPIOA3	ANA3&VREFLA&CMPA_IN2			
17	—	—	GPIOB7	GPIOB7	ANB7&CMPB_IN2			
18	13	—	GPIOC5	GPIOC5	DACA_O	XB_IN7		
19	—	—	GPIOB6	GPIOB6	ANB6&CMPB_IN1			
20	—	—	GPIOB5	GPIOB5	ANB5&CMPC_IN2			
21	14	—	GPIOB4	GPIOB4	ANB4&CMPC_IN1			
22	15	9	VDDA	VDDA				
23	16	10	VSSA	VSSA				
24	17	11	GPIOB0	GPIOB0	ANB0&CMPB_IN3			

Pinout

64 LQFP	48 LQFP	32 LQFP	Pin Name	Default	ALT0	ALT1	ALT2	ALT3
25	18	12	GPIOB1	GPIOB1	ANB1&CMPB_IN0	DACB_O		
26	19	—	VCAP	VCAP				
27	20	13	GPIOB2	GPIOB2	ANB2&VERFHB&CMPC_IN3			
28	21	—	GPIOB3	GPIOB3	ANB3&VREFLB&CMPC_IN0			
29	—	—	VDD	VDD				
30	22	14	VSS	VSS				
31	23	15	GPIOC6	GPIOC6	TA2	XB_IN3	CMP_REF	SS0_B
32	24	—	GPIOC7	GPIOC7	SS0_B	TXD0	XB_IN8	
33	25	16	GPIOC8	GPIOC8	MISO0	RXD0	XB_IN9	XB_OUT6
34	26	17	GPIOC9	GPIOC9	SCLK0	XB_IN4	TXD0	XB_OUT8
35	27	18	GPIOC10	GPIOC10	MOSI0	XB_IN5	MISO0	XB_OUT9
36	28	—	GPIOF0	GPIOF0	XB_IN6		SCLK1	
37	29	—	GPIOC11	GPIOC11	CANTX	SCL0	TXD1	
38	30	—	GPIOC12	GPIOC12	CANRX	SDA0	RXD1	
39	—	19	GPIOF2	GPIOF2	SCL0	XB_OUT6	MISO1	
40	—	20	GPIOF3	GPIOF3	SDA0	XB_OUT7	MOSI1	
41	—	—	GPIOF4	GPIOF4	TXD1	XB_OUT8	PWM_0X	PWM_FAULT6
42	—	—	GPIOF5	GPIOF5	RXD1	XB_OUT9	PWM_1X	PWM_FAULT7
43	31	—	VSS	VSS				
44	32	—	VDD	VDD				
45	33	21	GPIOE0	GPIOE0	PWM_0B			
46	34	22	GPIOE1	GPIOE1	PWM_0A			
47	35	23	GPIOE2	GPIOE2	PWM_1B			
48	36	24	GPIOE3	GPIOE3	PWM_1A			
49	37	—	GPIOC13	GPIOC13	TA3	XB_IN6	EWM_OUT_B	
50	38	—	GPIOF1	GPIOF1	CLKO1	XB_IN7	CMPD_O	
51	39	25	GPIOE4	GPIOE4	PWM_2B	XB_IN2		
52	40	26	GPIOE5	GPIOE5	PWM_2A	XB_IN3		
53	—	—	GPIOE6	GPIOE6	PWM_3B	XB_IN4		
54	—	—	GPIOE7	GPIOE7	PWM_3A	XB_IN5		
55	41	—	GPIOC14	GPIOC14	SDA0	XB_OUT4	PWM_FAULT4	
56	42	—	GPIOC15	GPIOC15	SCL0	XB_OUT5	PWM_FAULT5	
57	43	27	VCAP	VCAP				
58	—	—	GPIOF6	GPIOF6		PWM_3X		XB_IN2
59	—	—	GPIOF7	GPIOF7		CMPC_O	SS1_B	XB_IN3
60	44	28	VDD	VDD				
61	45	29	VSS	VSS				
62	46	30	TDO	TDO	GPIOD1			
63	47	31	TMS	TMS	GPIOD3			
64	48	32	TDI	TDI	GPIOD0			

11.2 Pinout diagrams

The following diagrams show pinouts for the packages. For each pin, the diagrams show the default function. However, many signals may be multiplexed onto a single pin.

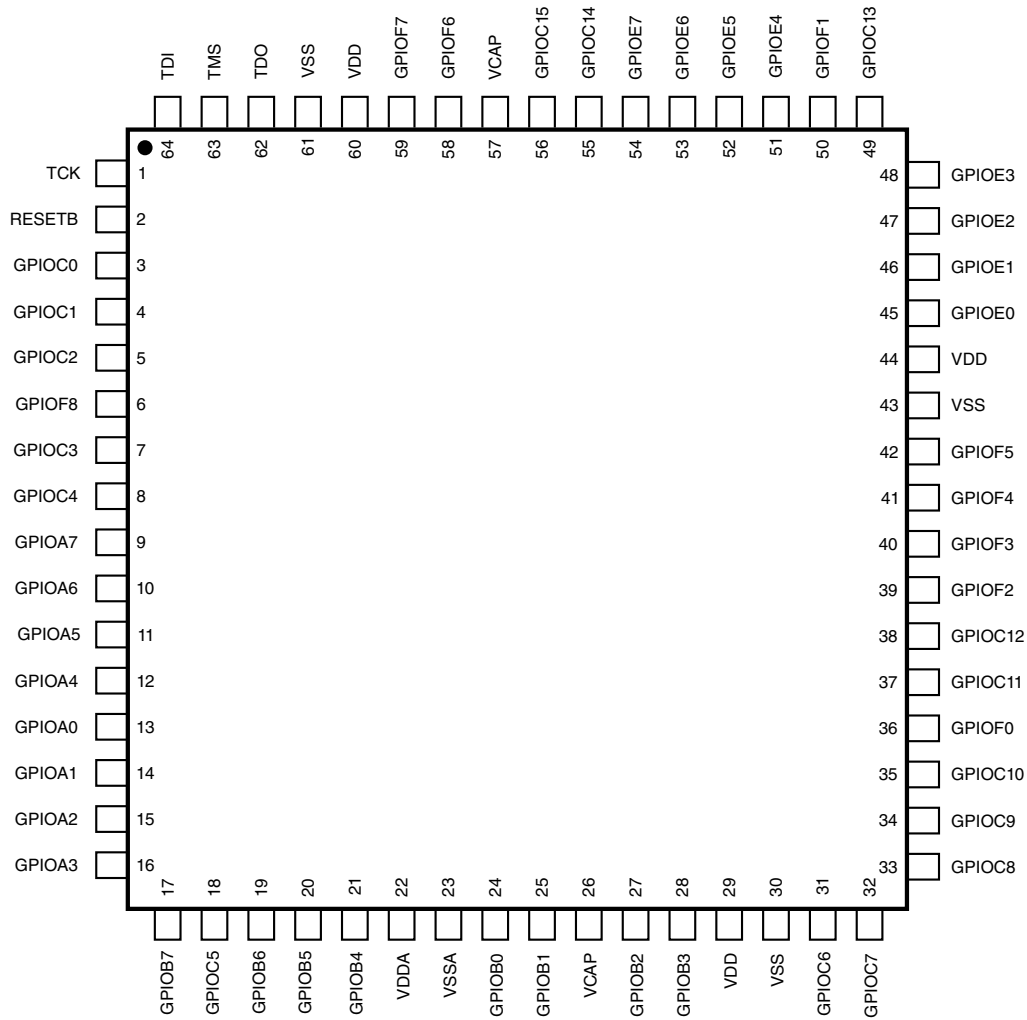

Figure 24. 64-pin LQFP

NOTE

The RESETB pin is a 3.3 V pin only.

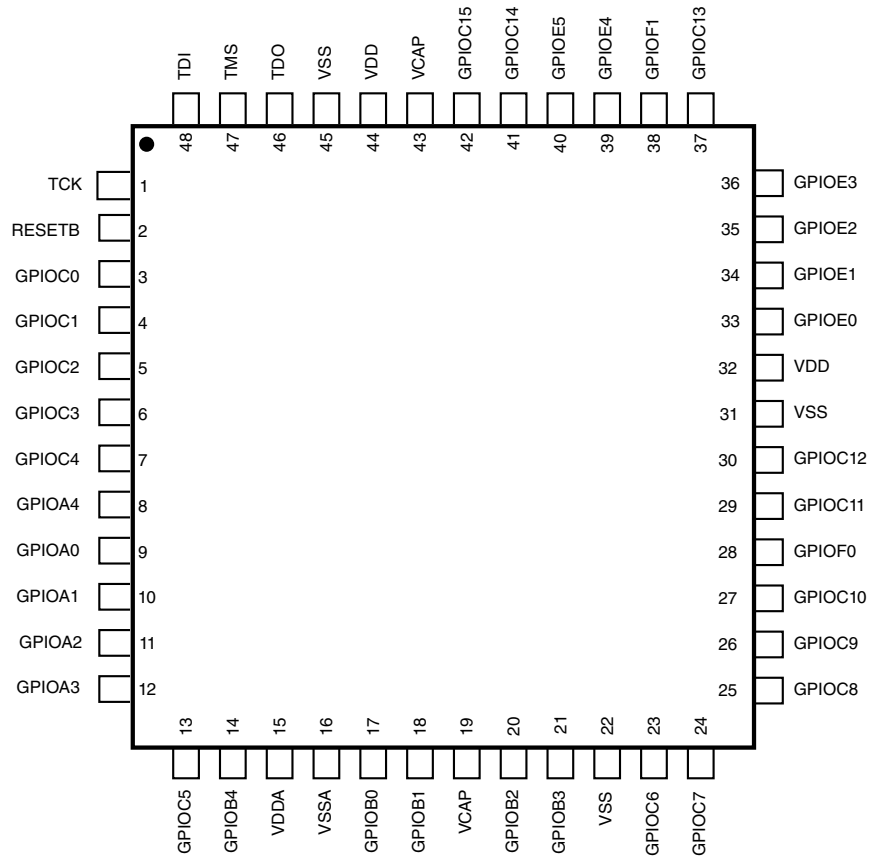

Figure 25. 48-pin LQFP

NOTE

The RESETB pin is a 3.3 V pin only.

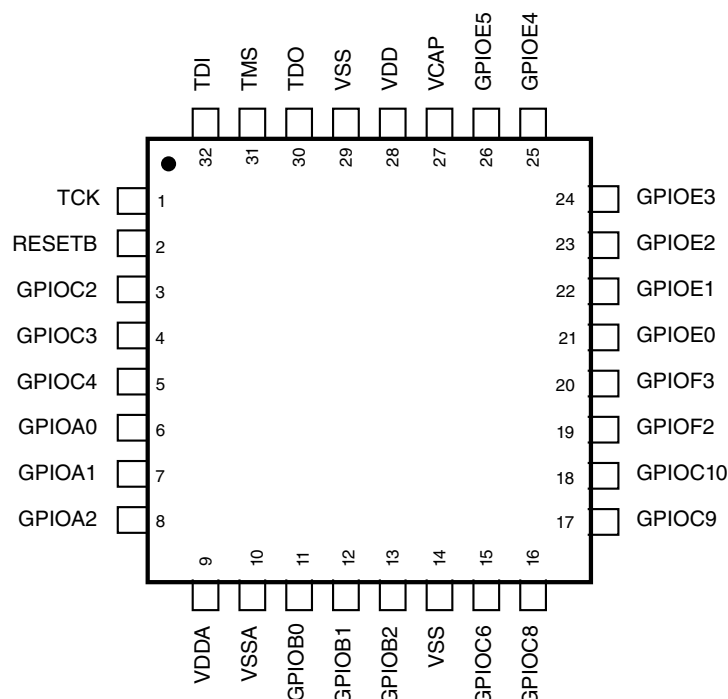

Figure 26. 32-pin LQFP and QFN

NOTE

The RESETB pin is a 3.3 V pin only.

12 Product documentation

The documents listed in [Table 36](#) are required for a complete description and to successfully design using the device. Documentation is available from local NXP distributors, NXP sales offices, or online at www.nxp.com.

Table 36. Device documentation

Topic	Description	Document Number
DSP56800E/DSP56800EX Reference Manual	Detailed description of the 56800EX family architecture, 32-bit digital signal controller core processor, and the instruction set	DSP56800ERM
MC56F827xx Reference Manual	Detailed functional description and programming model	MC56F827XXRM
MC56F827xx Data Sheet	Electrical and timing specifications, pin descriptions, and package information (this document)	MC56F827XXDS
MC56F82xxx Errata	Details any chip issues that might be present	MC56F82xxx_Errata

13 Revision History

The following table summarizes changes to this document since the release of the previous version.

Table 37. Revision History

Rev. No.	Date	Substantial Changes
2	10/2013	First public release
2.1	11/2013	<ul style="list-style-type: none"> In Table 2, added DACB_O signal description. In Obtaining package dimensions, changed 32-QFN's document number from '98ARE10566D' to '98ASA00473D'.
2.2	03/2016 - 05/2016	<ul style="list-style-type: none"> Corrected document part number MC56F827XXDS to MC56F827XX. In "12-bit ADC Electrical Specifications" table, corrected Max Gain Error to 0.990 to 1.010. In "Part identification" section, in "part number fields" table, added the 32QFN package identifier. In "Electrical design considerations" section, added additional section "Power-on Reset design considerations". Added new section "Power-on Reset design considerations". In "Peripheral highlights" section, added <ul style="list-style-type: none"> Periodic Interrupt Timer (PIT) Modules External Watchdog Monitor (EWM)
3.0	09/2016	<ul style="list-style-type: none"> Added products: 56F82746MLF, 56F82733MFM Removed PDB (Programmable Delay Block) mentions, because PDBs are not present in these devices. Added V and M temperature options to operating characteristics. Moved "Signal groups" section under "MC56F827xx signal and pin descriptions" section. In "Voltage and current operating ratings" section: updated note; in "Absolute Maximum Ratings" table, updated Ambient and Junction Temperature rows, also fixed broken footnotes. In "Power consumption operating behaviors" section, in "Current Consumption" table: added columns and data for Maximum at 3.6V, 125°C, fixed broken footnotes. In "Thermal operating requirements" section, updated Die junction temperature and Ambient temperature requirements. In "Relaxation Oscillator Timing" section, in "Relaxation Oscillator Electrical Specifications" table: <ul style="list-style-type: none"> Added data for "-40°C to 125°C" temperature range. For "8 MHz Output Frequency, Standby Mode frequency", 2 corrections were made. Fixed broken footnotes.
4	07/2018	<ul style="list-style-type: none"> Some updates in "Signal descriptions" table, e.g. V_{CAP} description, TCK row, GPIO rows "State During Reset" column corrected. In "Voltage and current operating requirements" table, updated the note. In "DC Electrical Characteristics at Recommended Operating Conditions" table, added a new row for I_{IL} and some footnotes (also with a new figure). In "SCI timing" table, typo fix for the Unit of pulse width. Thorough updates in "Power-on Reset design considerations" section, the second sub-section now named as "Unnecessary protection circuit" and contents clarified. In "Signal Multiplexing and Pin Assignments" section, typo fix in the "Not all CMPD pins ..." item. Minor editorial updates.

Table continues on the next page...

Table 37. Revision History (continued)

Rev. No.	Date	Substantial Changes
4.1	11/2018	<ul style="list-style-type: none">• Added new part number MC56F82748MLH.• Some updates in the "Power supervisor" section.

How to Reach Us:**Home Page:**nxp.com**Web Support:**nxp.com/support

Information in this document is provided solely to enable system and software implementers to use NXP products. There are no express or implied copyright licenses granted hereunder to design or fabricate any integrated circuits based on the information in this document. NXP reserves the right to make changes without further notice to any products herein.

NXP makes no warranty, representation, or guarantee regarding the suitability of its products for any particular purpose, nor does NXP assume any liability arising out of the application or use of any product or circuit, and specifically disclaims any and all liability, including without limitation consequential or incidental damages. "Typical" parameters that may be provided in NXP data sheets and/or specifications can and do vary in different applications, and actual performance may vary over time. All operating parameters, including "typicals," must be validated for each customer application by customer's technical experts. NXP does not convey any license under its patent rights nor the rights of others. NXP sells products pursuant to standard terms and conditions of sale, which can be found at the following address: nxp.com/SalesTermsandConditions.

While NXP has implemented advanced security features, all products may be subject to unidentified vulnerabilities. Customers are responsible for the design and operation of their applications and products to reduce the effect of these vulnerabilities on customer's applications and products, and NXP accepts no liability for any vulnerability that is discovered. Customers should implement appropriate design and operating safeguards to minimize the risks associated with their applications and products.

NXP, the NXP logo, NXP SECURE CONNECTIONS FOR A SMARTER WORLD, COOLFLUX, EMBRACE, GREENCHIP, HITAG, I2C BUS, ICODE, JCOP, LIFE VIBES, MIFARE, MIFARE CLASSIC, MIFARE DESFire, MIFARE PLUS, MIFARE FLEX, MANTIS, MIFARE ULTRALIGHT, MIFARE4MOBILE, MIGLO, NTAG, ROADLINK, SMARTLX, SMARTMX, STARPLUG, TOPFET, TRENCHMOS, UCODE, Freescale, the Freescale logo, AltiVec, C-5, CodeTEST, CodeWarrior, ColdFire, ColdFire+, C-Ware, the Energy Efficient Solutions logo, Kinetis, Layerscape, MagniV, mobileGT, PEG, PowerQUICC, Processor Expert, QorIQ, QorIQ Qonverge, Ready Play, SafeAssure, the SafeAssure logo, StarCore, Symphony, VortiQa, Vybrid, Airfast, BeeKit, BeeStack, CoreNet, Flexis, MXC, Platform in a Package, QUICC Engine, SMARTMOS, Tower, TurboLink, and UMEMS are trademarks of NXP B.V. All other product or service names are the property of their respective owners. AMBA, Arm, Arm7, Arm7TDMI, Arm9, Arm11, Artisan, big.LITTLE, Cordio, CoreLink, CoreSight, Cortex, DesignStart, DynamIQ, Jazelle, Keil, Mali, Mbed, Mbed Enabled, NEON, POP, RealView, SecurCore, Socrates, Thumb, TrustZone, ULINK, ULINK2, ULINK-ME, ULINK-PLUS, ULINKpro, μ Vision, Versatile are trademarks or registered trademarks of Arm Limited (or its subsidiaries) in the US and/or elsewhere. The related technology may be protected by any or all of patents, copyrights, designs and trade secrets. All rights reserved. Oracle and Java are registered trademarks of Oracle and/or its affiliates. The Power Architecture and Power.org word marks and the Power and Power.org logos and related marks are trademarks and service marks licensed by Power.org.

© 2013–2018 NXP B.V.

Document Number MC56F827XXDS
Revision 4.1, 11/2018



Looking for pricing, stock, or lifecycle information?

Click below to explore more details on WIN SOURCE:

⊖ [View MC56F82746VLF on WIN SOURCE](#)

⊖ [NXP / Nexperia Information](#)

Optimize Your Supply Chain with WIN SOURCE Solutions

- ✓ Global Sourcing Solution
- ✓ Obsolete Management
- ✓ Cost Control Management
- ✓ Shortage Management
- ✓ Alternative Solution
- ✓ Excess Inventory Management