



THE DATASHEET OF MAX4709ESE+





Fault-Protected, Single 8-to-1/ Dual 4-to-1 Multiplexers

General Description

The MAX4708/MAX4709 8-to-1 and dual 4-to-1 fault-protected multiplexers are pin compatible with the industry-standard DG508/DG509. The MAX4708/MAX4709 are similar to the MAX4508/MAX4509, but these devices do not have clamp diodes to the supply rails on the switch outputs. These multiplexers feature fault-protected inputs, rail-to-rail signal-handling capability, and do not require power-supply sequencing.

Both devices offer $\pm 40\text{V}$ overvoltage protection with the supplies off, $\pm 36\text{V}$ protection with the supplies on, and feature 400Ω (max) on-resistance with 15Ω (max) matching between channels. The MAX4708/MAX4709 operate with dual supplies of $\pm 4.5\text{V}$ to $\pm 20\text{V}$ or a single supply of $+9\text{V}$ to $+36\text{V}$. All digital inputs have TTL logic-compatible thresholds, ensuring both TTL and CMOS logic compatibility when using a single $+12\text{V}$ supply or dual $\pm 15\text{V}$ supplies.

For low-voltage applications requiring fault protection, refer to the MAX4711/MAX4712/MAX4713 data sheet.

Applications

Data-Acquisition Systems
Industrial and Process Control
Avionics
Signal Routing
Redundancy/Backup Systems
ATE Systems
Hot Swap

Features

- ◆ No Power-Supply Sequencing Required
- ◆ All Channels Off with Power Off
- ◆ Rail-to-Rail Signal Handling
- ◆ 400Ω (max) On-Resistance
- ◆ $\pm 40\text{V}$ Fault Protection with Power Off
- ◆ $\pm 25\text{V}$ Fault Protection with $\pm 15\text{V}$ Supplies
- ◆ 100ns Fault-Response Time
- ◆ $\pm 4.5\text{V}$ to $\pm 20\text{V}$ Dual Supplies
- ◆ $+9\text{V}$ to $+36\text{V}$ Single Supply
- ◆ TTL/CMOS-Compatible Logic Inputs

Ordering Information

PART	TEMP RANGE	PIN-PACKAGE
MAX4708ESE	-40°C to $+85^{\circ}\text{C}$	16 Narrow SO
MAX4708EWE	-40°C to $+85^{\circ}\text{C}$	16 Wide SO
MAX4708EPE	-40°C to $+85^{\circ}\text{C}$	16 Plastic DIP
MAX4709ESE	-40°C to $+85^{\circ}\text{C}$	16 Narrow SO
MAX4709EWE	-40°C to $+85^{\circ}\text{C}$	16 Wide SO
MAX4709EPE	-40°C to $+85^{\circ}\text{C}$	16 Plastic DIP

Pin Configurations/Functional Diagrams

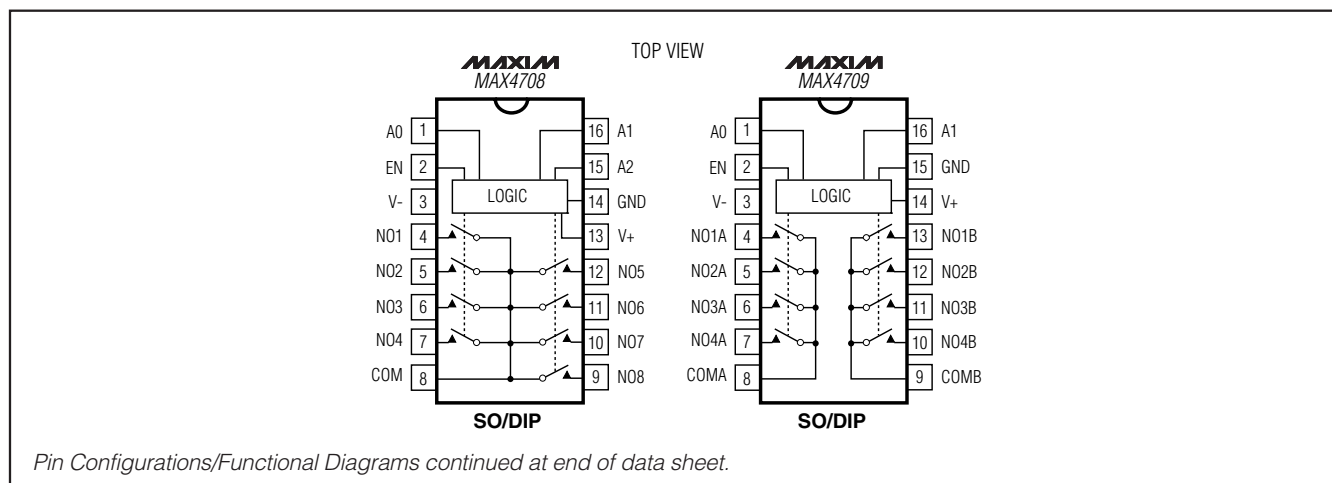

Fault-Protected, Single 8-to-1/ Dual 4-to-1 Multiplexers

ABSOLUTE MAXIMUM RATINGS

(All Voltages Referenced to GND)

V+	-0.3V to +44.0V
V-	-44.0V to +0.3V
V+ to V-.....	-0.3V to +44.0V
COM_, A_, EN (Note 1).....	(V+ + 0.3V) to (V- - 0.3V)
NO_.....	(V+ - 40V) to (V- + 40V)
NO_ to COM_.....	-36V to +36V
NO_ Voltage with Switch Power On	-30V to +30V
NO_ Voltage with Switch Power Off	-40V to +40V
Continuous Current into any Terminal.....	±30mA
Peak Current into any Terminal (pulsed at 1ms, 10% duty cycle).....	±100mA

Continuous Power Dissipation (T_A = +70°C)

16 Narrow SO (derate 8.70mW/°C above +70°C)	696mW
16 Plastic DIP (derate 10.53mW/°C above +70°C)	842mW
16 Wide SO (derate 9.52mW/°C above +70°C).....	762mW
Operating Temperature Range	
MAX4708E_E/MAX4709E_E	-40°C to +85°C
Junction Temperature	+150°C
Storage Temperature Range	-65°C to +160°C
Lead Temperature (soldering, 10s)	+300°C

Note 1: COM_, EN, and A_ pins are not fault protected. Signals on COM_, EN, or A_ exceeding V+ or V- are clamped by internal diodes. Limit forward-diode current to maximum current rating.

Stresses beyond those listed under "Absolute Maximum Ratings" may cause permanent damage to the device. These are stress ratings only, and functional operation of the device at these or any other conditions beyond those indicated in the operational sections of the specifications is not implied. Exposure to absolute maximum rating conditions for extended periods may affect device reliability.

ELECTRICAL CHARACTERISTICS—Dual Supplies

(V+ = +15V, V- = -15V, V_{A_H} = +2.4V, V_{A_L} = +0.8V, V_{EN} = +2.4V, T_A = T_{MIN} to T_{MAX}, unless otherwise noted. Typical values are at T_A = +25°C.) (Note 2)

PARAMETER	SYMBOL	CONDITIONS	T _A	MIN	TYP	MAX	UNITS	
ANALOG SWITCH								
Fault-Free Analog Signal Range	V _{NO_}	(Notes 3, 4)	E	V-		V+	V	
On-Resistance	R _{ON}	V _{COM_} = ±10V, I _{NO_} = 0.2mA	+25°C		300	400	Ω	
			E			500		
On-Resistance Match Between Channels	ΔR _{ON}	V _{COM_} = ±10V, I _{NO_} = 0.2mA (Note 5)	+25°C			15	Ω	
			E			20		
NO_ Off-Leakage Current	I _{NO_(OFF)}	V _{COM_} = ±10V, V _{NO_} = ±10V (Note 6)	+25°C	-0.5		+0.5	nA	
			E	-5		+5		
COM_ Off-Leakage Current	I _{COM_(OFF)}	V _{COM_} = ±10V, V _{NO_} = ±10V (Note 6)	MAX4708	+25°C	-2		+2	nA
				E	-20		+20	
			MAX4709	+25°C	-1		+1	
				E	-10		+10	
COM_ On-Leakage Current	I _{COM_(ON)}	V _{COM_} = ±10V, V _{NO_} = ±10V, or floating (Note 6)	MAX4708	+25°C	-2		+2	nA
				E	-25		+25	
			MAX4709	+25°C	-1		+1	
				E	-15		+15	

Fault-Protected, Single 8-to-1/ Dual 4-to-1 Multiplexers

MAX4708/MAX4709

ELECTRICAL CHARACTERISTICS—Dual Supplies (continued)

(V₊ = +15V, V₋ = -15V, V_{A_H} = +2.4V, V_{A_L} = +0.8V, V_{EN} = +2.4V, T_A = T_{MIN} to T_{MAX}, unless otherwise noted. Typical values are at T_A = +25°C.) (Note 2)

PARAMETER	SYMBOL	CONDITIONS	T _A	MIN	TYP	MAX	UNITS
FAULT PROTECTION							
Fault-Protected Analog Signal Range (Notes 3, 4)	V _{NO_}	Power on	+25°C	-25		+25	V
		Power off		-40		+40	
COM ₋ Output Leakage Current, Supplies On	I _{COM_}	V _{NO_} = ±25V, V _{EN} = 0	+25°C	-1		+1	μA
			E	-10		+10	
NO ₋ Input Leakage Current, Supplies On	I _{NO_}	V _{NO_} = ±25V, V _{COM_} = ±10V, V _{EN} = 0	+25°C	-1		+1	μA
			E	-10		+10	
NO ₋ Input Leakage Current, Supplies Off	I _{NO_}	V _{NO_} = ±40V, V _{COM_} = 0, V ₊ = 0, V ₋ = 0	+25°C	-1		+1	μA
			E	-10		+10	
Fault-Trip Threshold			E	V ₋ - 0.4		V ₊ + 0.4	V
±Fault Output Turn-Off Delay		R _L = 10kΩ, V _{NO_} = ±25V	+25°C		100		ns
±Fault Recovery Time		R _L = 10kΩ, V _{NO_} = ±25V	+25°C		1.5		μs
LOGIC INPUT (V_{EN}, V_{A_})							
Logic Threshold High	V _{IH}		E	2.4			V
Logic Threshold Low	V _{IL}		E			0.8	V
Input Leakage Current	I _{IN}	V _{A_} = 0.8V or 2.4V	E	-1		+1	μA
SWITCH DYNAMIC CHARACTERISTICS							
Enable Turn-On Time	t _{ON}	V _{NO_} = ±10V, R _L = 1kΩ, C _L = 35pF, Figure 3 (Note 7)	+25°C		160	275	ns
			E			400	
Enable Turn-Off Time	t _{OFF}	V _{NO_} = ±10V, R _L = 1kΩ, C _L = 35pF, Figure 3 (Note 7)	+25°C		120	200	ns
			E			250	
Transition Time	t _{TRANS}	R _L = 1kΩ, C _L = 35pF, Figure 2 (Note 7)	+25°C		170	350	ns
			E			500	
Settling Time	t _{SETT}	V _{NO_} = 5V, R _L = 1kΩ, C _L = 35pF	E	0.1%	1		μs
				0.01%	2.5		
Break-Before-Make Time Delay	t _{BBM}	V _{NO_} = ±10V, R _L = 1kΩ, Figure 4 (Note 4)	E	10	80		ns
Charge Injection	Q	V _{NO_} = 0, R _S = 0, C _L = 1.0nF, Figure 5	+25°C		0		pC
Off-Isolation	V _{ISO}	f = 1MHz, V _{NO_} = 1V _{RMS} , R _L = 75Ω, C _L = 15pF, Figure 6 (Note 8)	+25°C		-70		dB

Fault-Protected, Single 8-to-1/ Dual 4-to-1 Multiplexers

ELECTRICAL CHARACTERISTICS—Dual Supplies (continued)

(V+ = +15V, V- = -15V, V_{AH} = +2.4V, V_{AL} = +0.8V, V_{EN} = +2.4V, T_A = T_{MIN} to T_{MAX}, unless otherwise noted. Typical values are at T_A = +25°C.) (Note 2)

PARAMETER	SYMBOL	CONDITIONS	T _A	MIN	TYP	MAX	UNITS
Channel-to-Channel Crosstalk	V _{CT}	f = 1MHz, V _{NO-} = 1V _{RMS} , R _L = 75Ω, C _L = 15pF, Figure 7 (Note 9)	+25°C		-62		dB
NO_ Off-Capacitance	C _{NO_(OFF)}	f = 1MHz, Figure 8	+25°C		10		pF
COM_ Off-Capacitance	C _{COM_(OFF)}	f = 1MHz, Figure 8	+25°C		19		pF
				MAX4708		14	
COM_ On-Capacitance	C _{COM_(ON)}	f = 1MHz, Figure 8	+25°C		28		pF
				MAX4709		22	
POWER SUPPLY							
Power-Supply Range	V+, V-		E	±4.5		±20.0	V
V+ Supply Current	I+	All V _{A-} = 0 or 5V, V _{NO-} = 0, V _{EN} = 5V	+25°C		370	525	μA
			E			750	
V- Supply Current	I-	All V _{A-} = 0 or 5V, V _{NO-} = 0, V _{EN} = 5V	+25°C		200	300	μA
			E			400	
GND Supply Current	I _{GND}	All V _{A-} = 0 or 5V, V _{NO-} = 0, V _{EN} = 5V	+25°C		200	300	μA
			E			500	

ELECTRICAL CHARACTERISTICS—Single +12V Supply

(V+ = +12V, V- = 0, V_{AH} = +2.4V, V_{AL} = +0.8V, V_{EN} = +2.4V, T_A = T_{MIN} to T_{MAX}, unless otherwise noted. Typical values are at T_A = +25°C.) (Note 2)

PARAMETER	SYMBOL	CONDITIONS	T _A	MIN	TYP	MAX	UNITS	
ANALOG SWITCH								
Fault-Free Analog Signal Range	V _{NO-}	Power on or off (Note 3)	E	-0.3		V+	V	
On-Resistance	R _{ON}	V _{COM-} = 10V, I _{NO-} = 0.2mA	+25°C		630	950	Ω	
			E			1100		
On-Resistance Match Between Channels	ΔR _{ON}	V _{COM-} = 10V, I _{NO-} = 0.2mA (Note 5)	+25°C		10	35	Ω	
			C, E			50		
NO_ Off-Leakage Current	I _{NO_(OFF)}	V _{COM-} = 10V, 1V, V _{NO-} = 1V, 10V (Notes 6, 10)	+25°C		-0.5	0.01	nA	
			E			+10		
COM_ Off-Leakage Current	I _{COM_(OFF)}	V _{COM-} = 10V, 1V, V _{NO-} = 1V, 10V (Notes 6, 10)	+25°C	MAX4708		-2	+2	nA
				E			-20	
			E	MAX4709		-1	+1	
						-10	+10	

Fault-Protected, Single 8-to-1/ Dual 4-to-1 Multiplexers

MAX4708/MAX4709

ELECTRICAL CHARACTERISTICS—Single +12V Supply (continued)

(V₊ = +12V, V₋ = 0, V_{A_H} = +2.4V, V_{A_L} = +0.8V, V_{EN} = +2.4V, T_A = T_{MIN} to T_{MAX}, unless otherwise noted. Typical values are at T_A = +25°C.) (Note 2)

PARAMETER	SYMBOL	CONDITIONS	T _A	MIN	TYP	MAX	UNITS	
COM_ On-Leakage Current	I _{COM_(ON)}	V _{COM_} = 10V, 1V; V _{NO_} = 10V, 1V, or floating (Notes 6, 10)	MAX4708	+25°C	-2		+2	nA
				E	-25		+25	
			MAX4709	+25°C	-1		+1	
				E	-15		+15	
FAULT PROTECTION								
Fault-Protected Analog Signal Range (Notes 3, 10)	V _{NO_}	Power on	E	-36		+36	V	
		Power off		-40		+40		
COM_ Output Leakage Current, Supplies On	I _{COM_}	V _{NO_} = ±36V, V ₊ = 12V (Notes 3, 10)	+25°C	-1		+1	μA	
			E	-10		+10		
NO_ Input Leakage Current, Supplies On	I _{NO_}	V _{NO_} = ±36V, V _{COM_} = 0, V ₊ = 12V (Notes 3, 10)	+25°C	-1		+1	μA	
			E	-10		+10		
NO_ Input Leakage Current, Supply Off	I _{NO_}	V _{NO_} = ±40V, V ₊ = 0, V ₋ = 0 (Notes 3, 10)	+25°C	-1		+1	μA	
			E	-10		+10		
LOGIC INPUT (V_{EN}, V_{A_})								
Logic Threshold High	V _{IH}		E	2.4			V	
Logic Threshold Low	V _{IL}		E			0.8	V	
Input Leakage Current	I _{IN}	V _{A_} = 0.8V or 2.4V	E	-1	0.03	+1	μA	
SWITCH-DYNAMIC CHARACTERISTICS								
Enable Turn-On Time	t _{ON}	V _{COM_} = 10V, R _L = 2kΩ, C _L = 35pF, Figure 3 (Note 7)	+25°C		240	500	ns	
			E			700		
Enable Turn-Off Time	t _{OFF}	V _{COM_} = 10V, R _L = 2kΩ, C _L = 35pF, Figure 3 (Note 7)	+25°C		100	250	ns	
			E			350		
Transition Time	t _{TRANS}	R _L = 2kΩ, C _L = 35pF, Figure 2 (Note 7)	+25°C		180	400	ns	
			E			600		
Settling Time	t _{SETT}	V _{NO_} = 5V, R _L = 1kΩ, C _L = 35pF	E	0.1%	1		μs	
				0.01%	2.5			
Break-Before-Make Time Delay	t _{BBM}	V _{COM_} = 10V, R _L = 2kΩ, Figure 4 (Note 4)	+25°C	50	100		ns	
Charge Injection	Q	V _{NO_} = 0, R _S = 0, C _L = 1.0 nF, Figure 5	+25°C		2		pC	
NO_ Off-Capacitance	C _{NO_(OFF)}	f = 1MHz, V _{NO_} = 0, Figure 8	+25°C		5		pF	
COM_ Off-Capacitance	C _{COM_(OFF)}	f = 1MHz, V _{NO_} = 0, Figure 8	+25°C		5		pF	
COM_ On-Capacitance	C _{COM_(ON)}	f = 1MHz, V _{COM_} = V _{NO_} = 0, Figure 8	+25°C		28		pF	

Fault-Protected, Single 8-to-1/ Dual 4-to-1 Multiplexers

ELECTRICAL CHARACTERISTICS—Single +12V Supply (continued)

(V+ = +12V, V- = 0, V_{A_H} = +2.4V, V_{A_L} = +0.8V, V_{EN} = +2.4V, T_A = T_{MIN} to T_{MAX}, unless otherwise noted. Typical values are at T_A = +25°C.) (Note 2)

PARAMETER	SYMBOL	CONDITIONS	T _A	MIN	TYP	MAX	UNITS
Off-Isolation	V _{ISO}	f = 1MHz, V _{NO_} = 1V _{RMS} , R _L = 75Ω, C _L = 15pF, Figure 6 (Note 8)	+25°C		-70		dB
Channel-to-Channel Crosstalk	V _{CT}	f = 1MHz, V _{NO_} = 1V _{RMS} , R _L = 75Ω, C _L = 15pF, Figure 7 (Note 9)	+25°C		-62		dB
POWER SUPPLY							
Power-Supply Range	V+		E	9		36	V
V+ Supply Current	I+	All V _{A_} = V _{EN} = 5V, V _{NO_} = 0	+25°C		180	300	μA
			E			450	
		All V _{A_} = 0 or V+, V _{NO_} = 0, V _{EN} = 0 or V+	+25°C		112	250	
			E			375	

Note 2: The algebraic convention is used in this data sheet; the most negative value is shown in the minimum column.

Note 3: NO_ pins are fault protected and COM_ pins are not fault protected. The max input voltage on NO_ pins depends on the COM_ load configuration. Generally, the max input voltage is ±36V with ±15V supplies and a load referred to ground. For more detailed information, see the NO_ Input Voltage section.

Note 4: Guaranteed by design and not production tested.

Note 5: ΔR_{ON} = R_{ON}(MAX) - R_{ON}(MIN).

Note 6: Leakage parameters are 100% tested at the maximum rated hot temperature and guaranteed by correlation at T_A = +25°C.

Note 7: Dynamic testing is 100% functionally tested on the ATE system and correlated with the initial design characterization per Figures 2 and 3.

Note 8: Off-Isolation = 20 × log₁₀ (V_{COM_} / V_{NO_}), where V_{COM_} = output and V_{NO_} = input to open switch.

Note 9: Between any two analog inputs.

Note 10: Guaranteed by testing with dual supplies.

Typical Operating Characteristics

(V+ = +15V, V- = -15V, V_{EN} = +2.4V, T_A = +25°C, unless otherwise noted.)

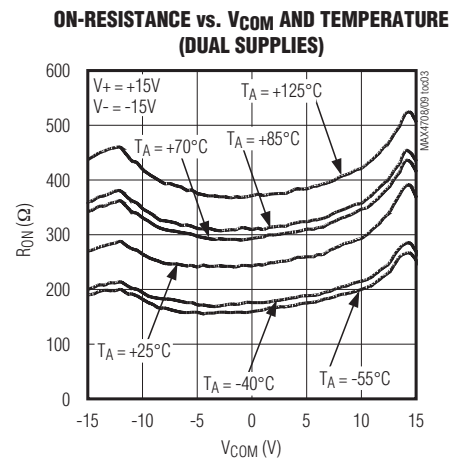
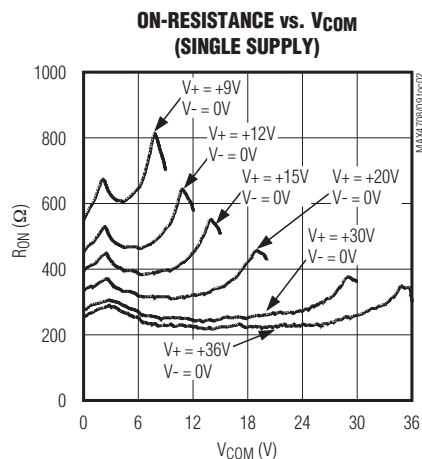
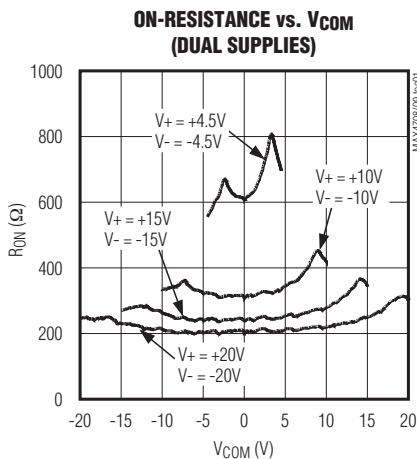

Fault-Protected, Single 8-to-1/ Dual 4-to-1 Multiplexers

MAX4708/MAX4709

Typical Operating Characteristics (continued)

($V_+ = +15V$, $V_- = -15V$, $V_{EN} = +2.4V$, $T_A = +25^\circ C$, unless otherwise noted.)

ON-RESISTANCE vs. V_{COM} AND TEMPERATURE (SINGLE SUPPLY)

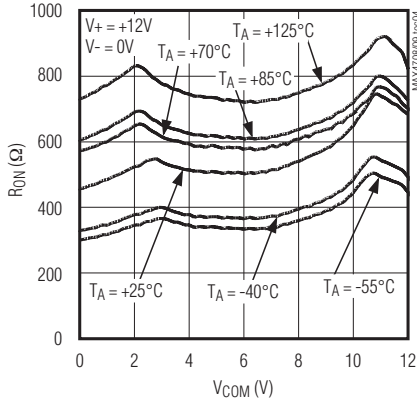

LEAKAGE CURRENT vs. TEMPERATURE

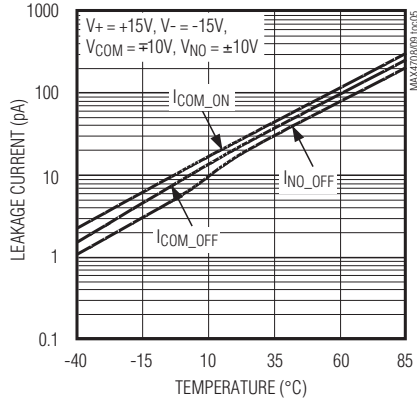

CHARGE INJECTION vs. V_{COM}

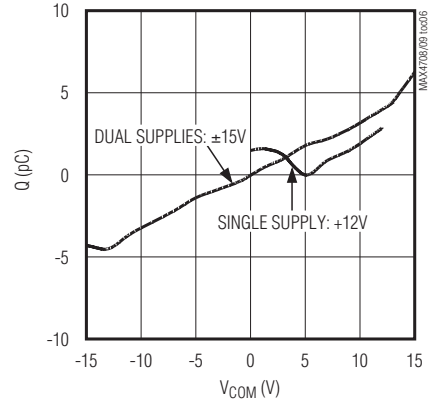

ENABLE TURN-ON/OFF TIMES vs. SUPPLY VOLTAGE (DUAL SUPPLIES)

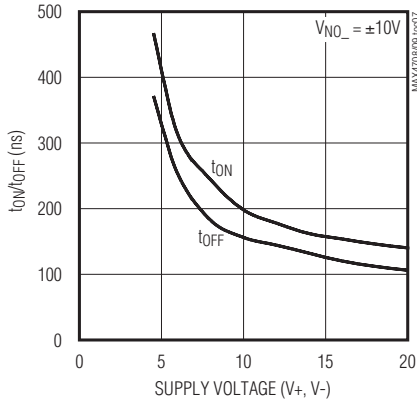

ENABLE TURN-ON/OFF TIMES vs. SUPPLY VOLTAGE (SINGLE SUPPLY)

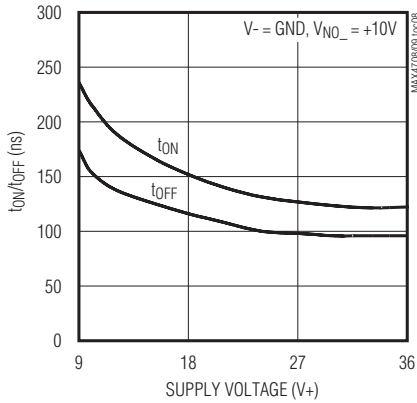

ENABLE ON/OFF TIMES vs. TEMPERATURE

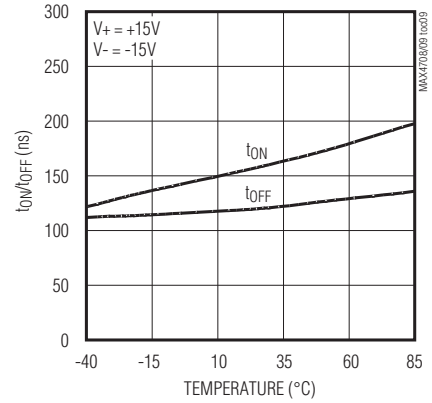

SUPPLY CURRENT vs. TEMPERATURE ($V_A = 0$)

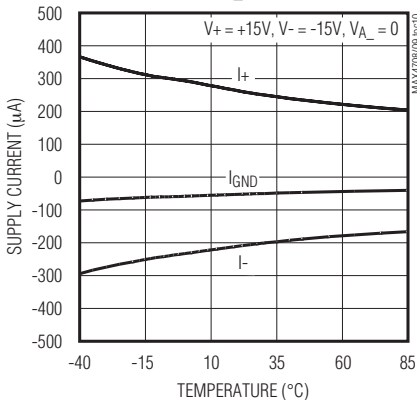

SUPPLY CURRENT vs. TEMPERATURE ($V_A = +5V$)

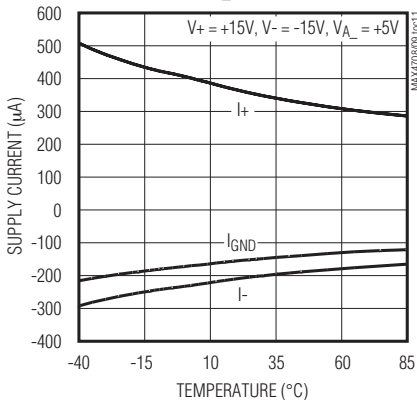

LOGIC-LEVEL THRESHOLD VOLTAGE vs. SUPPLY VOLTAGE

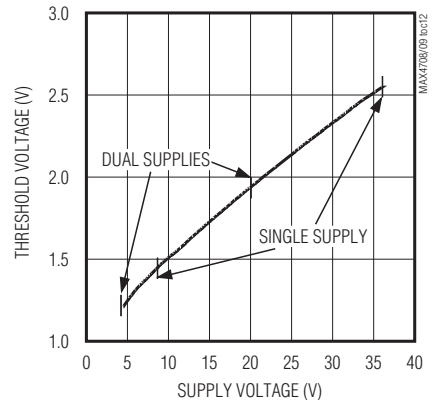

Fault-Protected, Single 8-to-1/ Dual 4-to-1 Multiplexers

Typical Operating Characteristics (continued)

(V+ = +15V, V- = -15V, VEN = +2.4V, TA = +25°C, unless otherwise noted.)

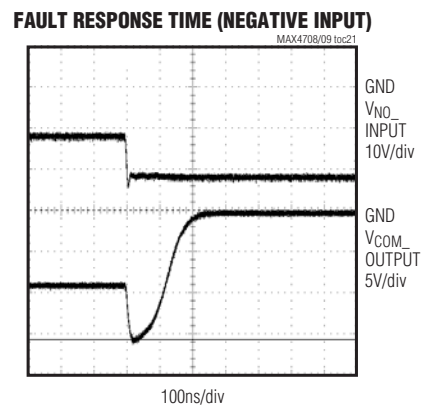
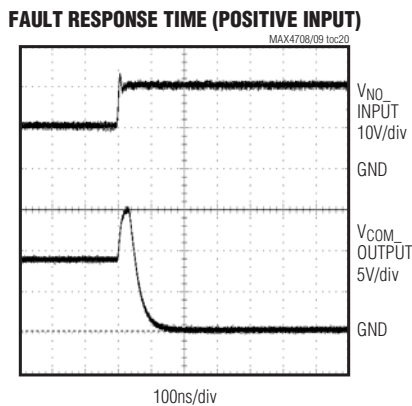
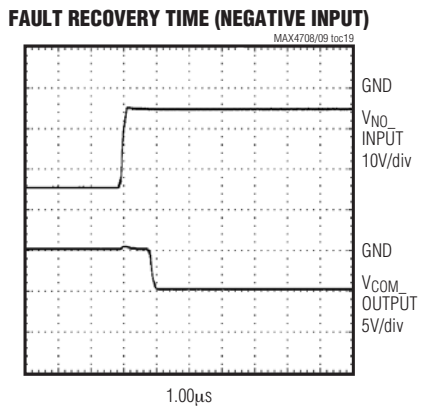
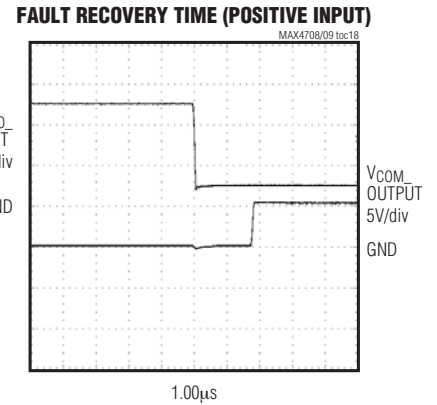
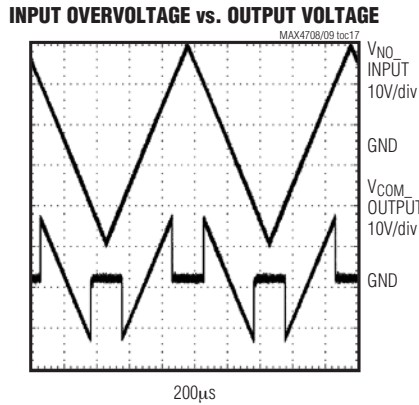
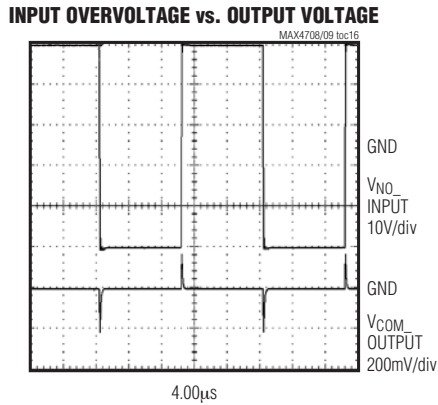
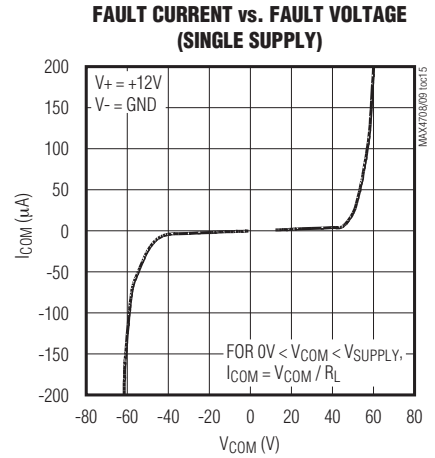
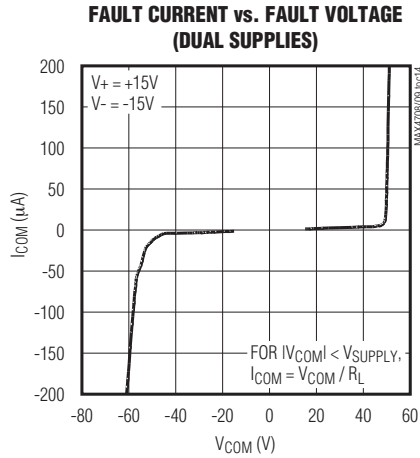
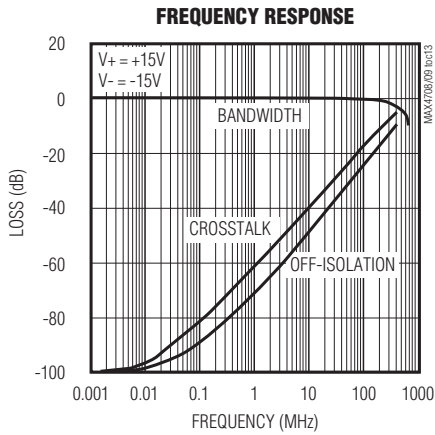

Fault-Protected, Single 8-to-1/ Dual 4-to-1 Multiplexers

Pin Descriptions

MAX4708 (Single 8-to-1 Mux)

PIN	NAME	FUNCTION
1	A0	Address Bit 0
2	EN	Mux Enable
3	V-	Negative Supply Voltage. Bypass to GND with a 0.1 μ F capacitor.
4	NO1	Channel Input 1
5	NO2	Channel Input 2
6	NO3	Channel Input 3
7	NO4	Channel Input 4
8	COM	Analog Output
9	NO8	Channel Input 8
10	NO7	Channel Input 7
11	NO6	Channel Input 6
12	NO5	Channel Input 5
13	V+	Positive Supply Voltage. Bypass to GND with a 0.1 μ F capacitor.
14	GND	Ground
15	A2	Address Bit 2
16	A1	Address Bit 1

MAX4709 (Dual 4-to-1 Mux)

PIN	NAME	FUNCTION
1	A0	Address Bit 0
2	EN	Mux Enable
3	V-	Negative Supply Voltage. Bypass to GND with a 0.1 μ F capacitor.
4	NO1A	Channel Input 1A
5	NO2A	Channel Input 2A
6	NO3A	Channel Input 3A
7	NO4A	Channel Input 4A
8	COMA	Mux Output A
9	COMB	Mux Output B
10	NO4B	Channel Input 4B
11	NO3B	Channel Input 3B
12	NO2B	Channel Input 2B
13	NO1B	Channel Input 1B
14	V+	Positive Supply Voltage. Bypass to GND with a 0.1 μ F capacitor.
15	GND	Ground
16	A1	Address Bit 1

MAX4708/MAX4709

Truth Tables

MAX4708 (Single 8-to-1 Mux)

A2	A1	A0	EN	ON SWITCH
X	X	X	0	None
0	0	0	1	NO1
0	0	1	1	NO2
0	1	0	1	NO3
0	1	1	1	NO4
1	0	0	1	NO5
1	0	1	1	NO6
1	1	0	1	NO7
1	1	1	1	NO8

X = Don't care.

MAX4709 (Dual 4-to-1 Mux)

A1	A0	EN	COMA	COMB
X	X	0	None	None
0	0	1	NO1A	NO1B
0	1	1	NO2A	NO2B
1	0	1	NO3A	NO3B
1	1	1	NO4A	NO4B

Fault-Protected, Single 8-to-1/ Dual 4-to-1 Multiplexers

Detailed Description

Several unique features differentiate the MAX4708/MAX4709 from traditional fault-protected multiplexers. First, instead of the three series FETs utilized in older designs, the MAX4708/MAX4709 design employs two parallel FETs for lower on-resistance and improved flatness. Second, older devices limited the range of signal amplitudes the switch could pass by as much as 3V below the supply rails. The MAX4708/MAX4709 feature rail-to-rail signal handling that allows the devices to transmit signals with amplitudes at or slightly beyond the supply rails. Finally, in former designs (MAX4508/MAX4509), when a fault occurred, the devices clamped and held the output voltage at the appropriate supply rail until the fault was removed. Instead, the MAX4708/MAX4709 now disconnect COM_o from NO_o during a fault condition, making COM_o a high-impedance output as long as the fault is present. Operation is identical for both positive and negative fault polarities.

When the NO_o voltage ranges beyond supply rails (fault condition), the NO_o input becomes high impedance, regardless of the switch state or load resistance. If power is removed, and the fault voltage is still present, the NO_o terminals remain high impedance. The fault voltage can be up to ±40V, with V₊ = V₋ = 0.

The COM_o pins are not fault protected. Limit any voltage sources connected to COM_o to the supply rails.

Figure 1 shows the internal construction of a single normally open (NO) switch, with the analog signal paths shown in bold. The parallel combination of N-channel FET N1 and P-channel FET P1 form the analog switch. During normal operation, these FETs are driven on and off simultaneously according to the control voltages on A_o. During a fault condition, both FETs turn off.

NO_o Input Voltage

The maximum allowable input voltage for safe operation depends on whether supplies are on or off, and the load configuration on COM_o. If COM_o is referred to a voltage other than ground, but within the supplies, V_{NO_o} can range higher or lower than the supplies, provided the absolute value of |V_{NO_o} - V_{COM_o}| is less than 40V.

For example, with V₊ = V₋ = 0, if the load is referred to +10V at COM_o, then the NO_o voltage range can be from +50V to -30V. If the supplies are ±15V and COM_o is referenced to ground through a load, the maximum NO_o voltage is ±36V. If the supplies are off and the COM output is referenced to ground, the maximum NO_o voltage is ±40V.

Normal Operation

Two comparators continuously compare the voltage on NO_o with V₊ and V₋ supply voltages. When the signal

on NO_o ranges between V₊ and V₋, the multiplexer operates normally, with FETs N1 and P1 turning on and off in response to the control signals on A_o (Figure 1). When the switch state is on, the parallel combination of N1 and P1 forms a low-value resistor between NO_o and COM_o so that signals pass equally well in either direction. When the switch state is off, both NO_o and COM_o are high-impedance inputs.

Fault Conditions

A fault condition occurs when the voltage at any NO_o input exceeds the supply rail. At this point, the output of one of the two fault comparators goes high, effectively turning OFF both FETs N1 and P1. With the two FETs in the OFF position, both the switch input (NO_o) and the output (COM_o) go into a high-impedance state. They remain high impedance regardless of the state of the control voltages in A_o and EN, until the fault is removed. The input voltage must not exceed the absolute maximum rating at any moment (see the *Absolute Maximum Ratings* section).

A fault condition on the selected channel drives COM_o to a high-impedance state. However, the fault condition does not affect the performance of other channels. Therefore, while the selected channel is in fault condition, selecting another channel or operating under normal condition, drives COM_o out of high impedance.

Transient Fault Condition

When a fast rising or falling transient on NO_o exceeds V₊ or V₋, there is a 100ns delay before the fault protection turns on (see the *Typical Operating Characteristics*, Fault Response Time). COM_o follows NO_o until the fault protection turns on. This delay is due to the switch on-resistance and circuit capacitance to ground. When the input transient returns to within the supply rails, there is a longer output recovery time (see the *Typical Operating Characteristics*, Fault Response Times). These values depend on the COM_o output resistance and capacitance. Higher COM_o output resistance and capacitance increase the recovery times. The delays do not depend on the fault amplitude.

COM and A_o

The GND, COM_o, and A_o pins are not fault protected. ESD-protection diodes internally connect A_o to both V₊ and V₋. If a signal on GND, COM_o, or A_o exceeds V₊ or V₋ by more than 300mV, excessive current can flow to or from the supplies, possibly damaging the device.

Logic-Level Thresholds

The logic-level thresholds are CMOS and TTL compatible with V₊ = +15V and V₋ = -15V. Logic levels change as V₊ increases (see the *Typical Operating Characteristics*, Logic-Level Threshold Voltage vs. Supply Voltage.)

Fault-Protected, Single 8-to-1/ Dual 4-to-1 Multiplexers

MAX4708/MAX4709

Applications Information

Ground

V+ and GND power the internal logic and logic-level translators. The logic-level translators convert the logic-level inputs to V+ and V- to drive the gates of the internal FETs. In this design, there is no galvanic connection inside the MAX4708/MAX4709 between the analog signal paths and GND. ESD-protection diodes connect A₋ to V+ and V-.

Supply Current Reduction

Driving the logic signals rail-to-rail from 0 to +15V or -15V to +15V reduces the current consumption from 370μA (typ) to 200μA (typ) (see the *Electrical Characteristics* table, Power Supplies).

Power Supplies

The MAX4708/MAX4709 operate with bipolar supplies between ±4.5V and ±20V. The V+ and V- supplies need not be symmetrical, but V+ - V- cannot exceed the 44V absolute maximum rating.

The MAX4708/MAX4709 operate from single supplies between +9V and +36V when V- is connected to GND.

Chip Information

PROCESS: CMOS

SUBSTRATE INTERNALLY CONNECTED TO V+

Package Information

For the latest package outline information and land patterns, go to www.maxim-ic.com/packages.

PACKAGE TYPE	PACKAGE CODE	DOCUMENT NO.
16 Narrow SO	—	21-0041
16 Wide SO	—	21-0042
16 Plastic DIP	—	21-0043

Pin Configurations/Functional Diagrams (continued)

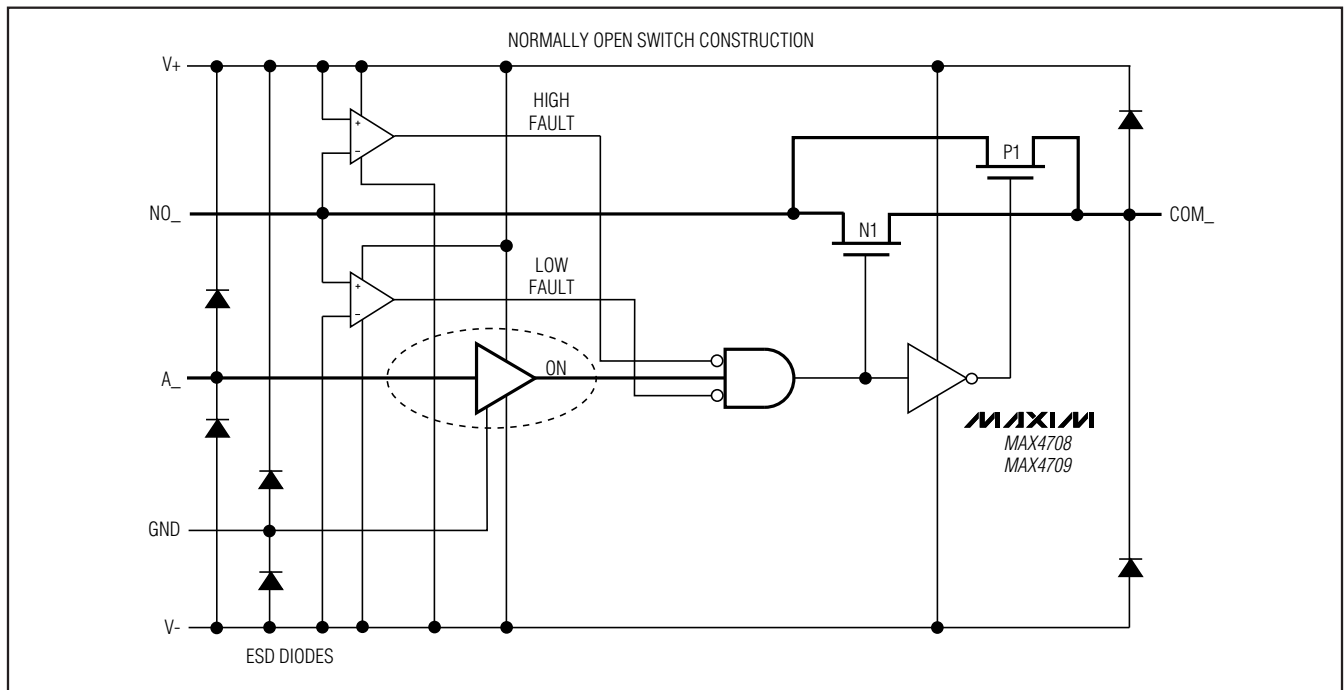

Figure 1. Functional Diagram

Fault-Protected, Single 8-to-1/ Dual 4-to-1 Multiplexers

Test Circuits/Timing Diagrams

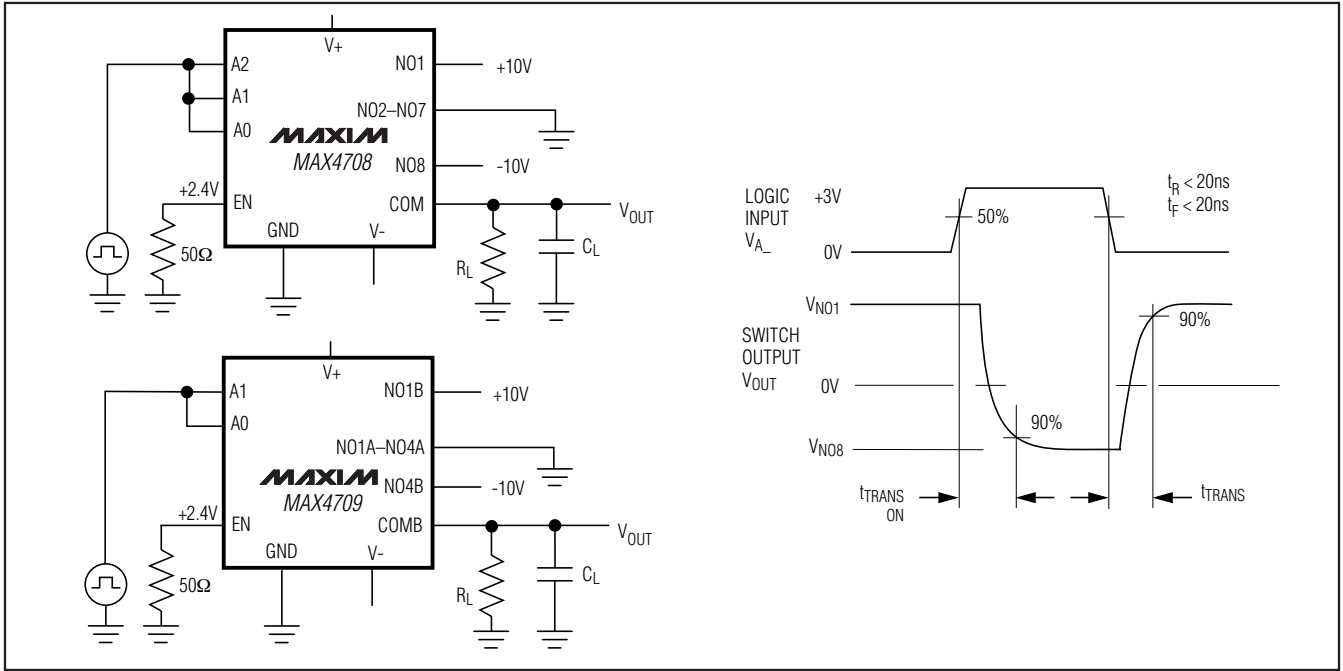

Figure 2. Address Transition Time

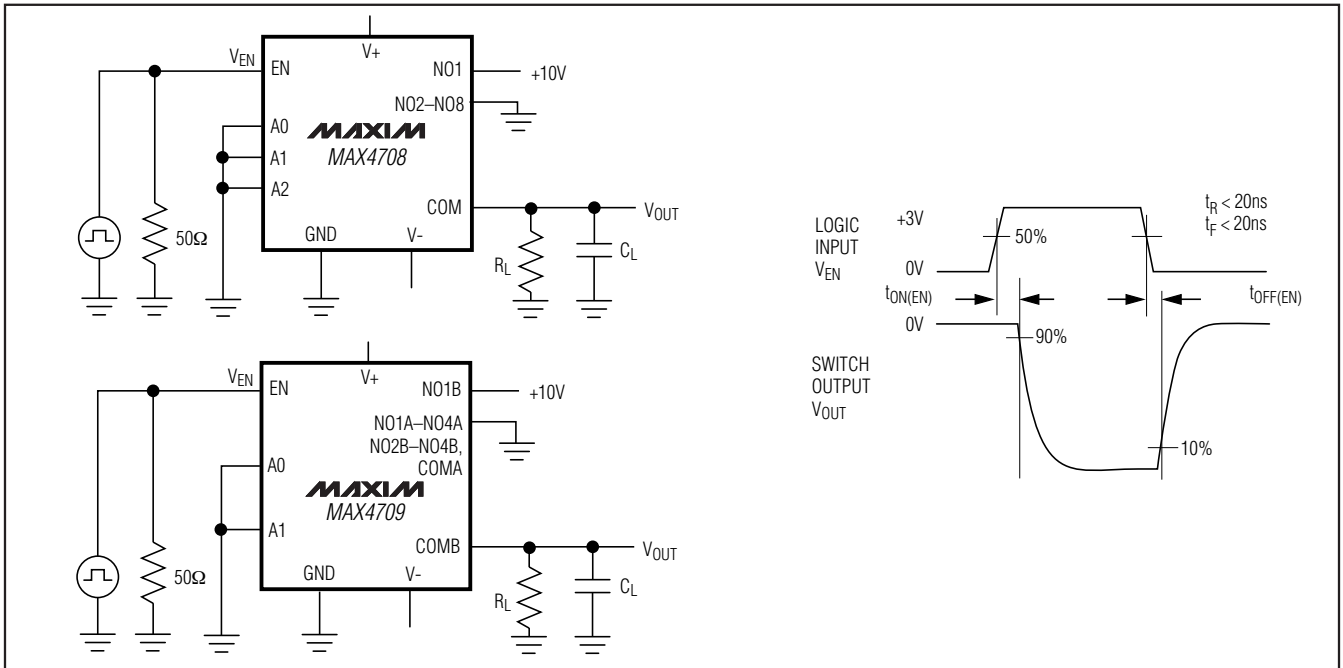

Figure 3. Enable Switching Time

Fault-Protected, Single 8-to-1/ Dual 4-to-1 Multiplexers

Test Circuits/Timing Diagrams (continued)

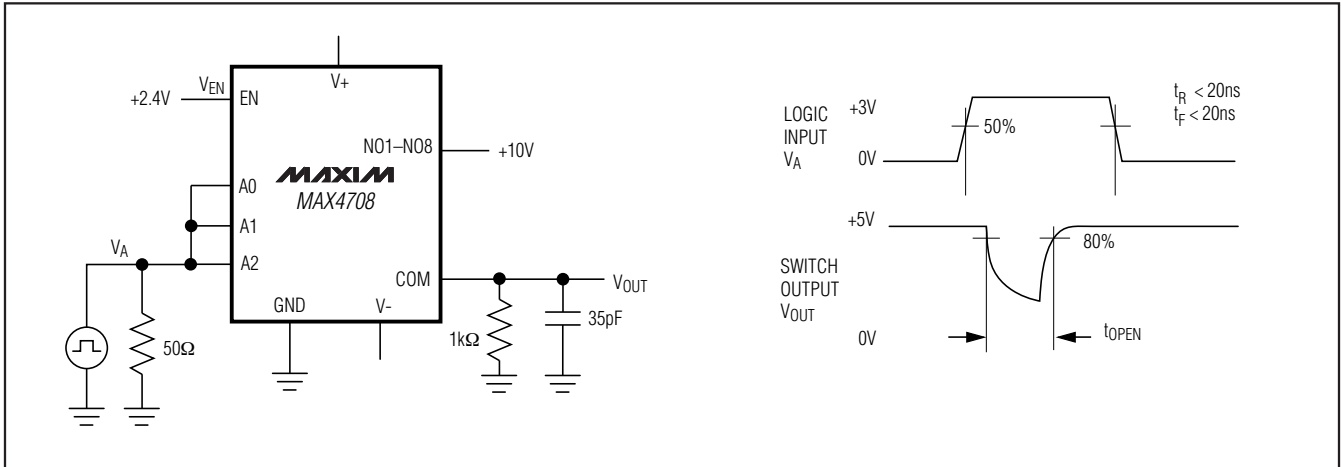

Figure 4. Break-Before-Make Interval

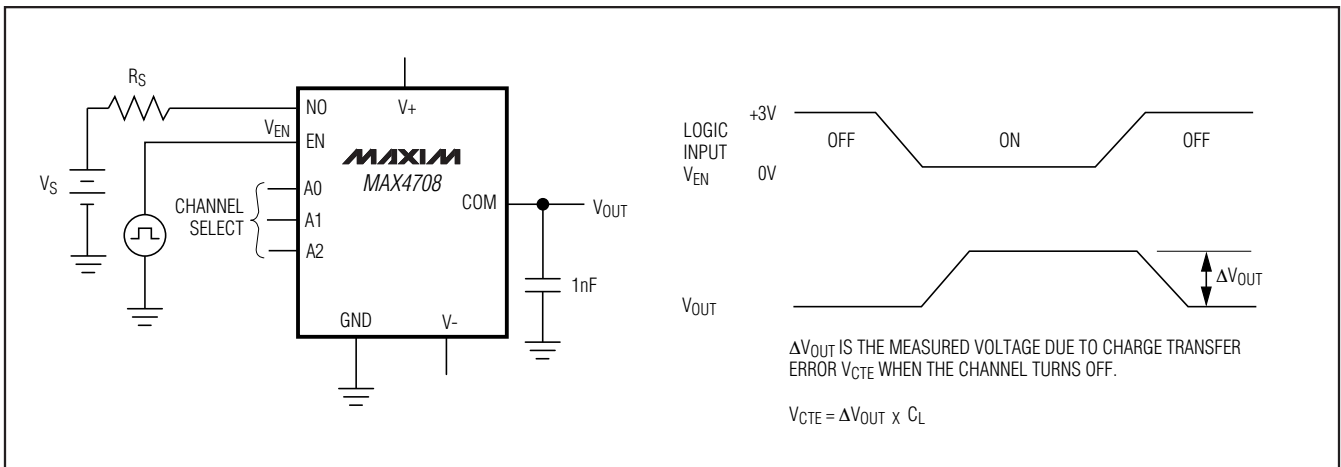

Figure 5. Charge Injection

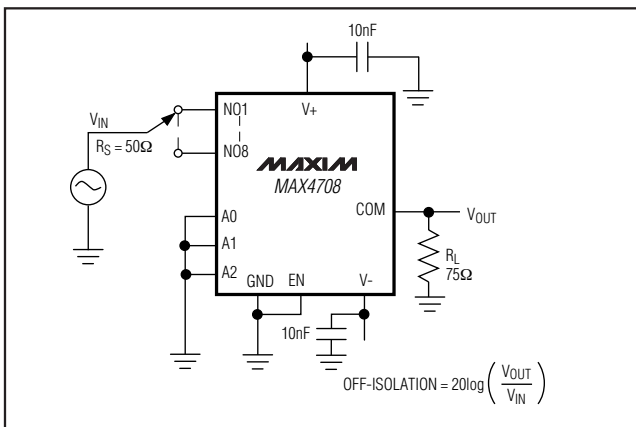

Figure 6. Off-Isolation

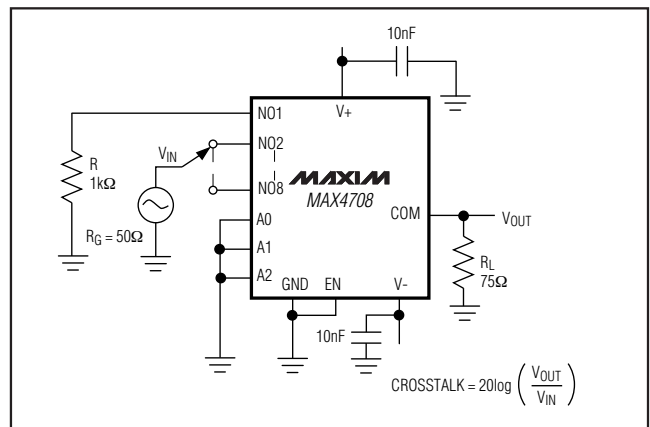

Figure 7. Crosstalk

Fault-Protected, Single 8-to-1/ Dual 4-to-1 Multiplexers

Test Circuits/Timing Diagrams (continued)

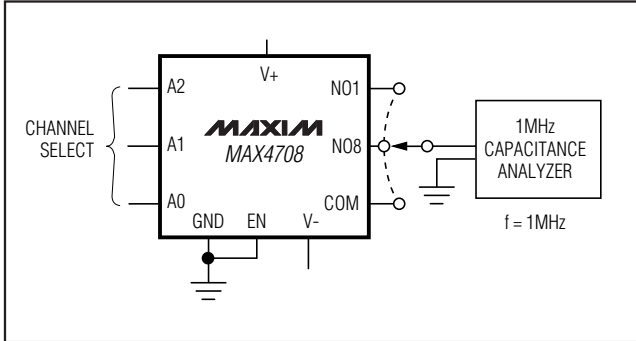

Figure 8. NO_, COM_ Capacitance

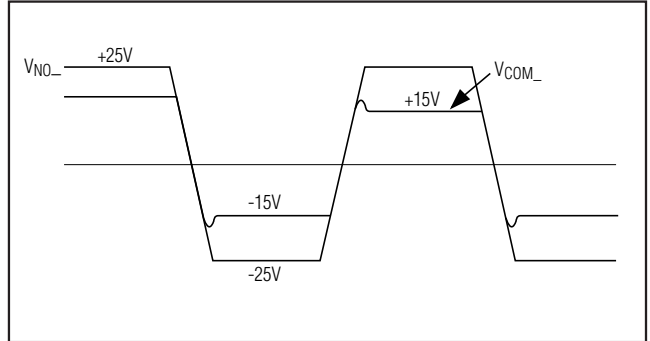

Figure 9. Transient Behavior of Fault Condition

Functional Diagrams/Truth Tables

MAXIM
MAX4708

MAX4708				
A2	A1	A0	EN	ON SWITCH
X	X	X	0	NONE
0	0	0	1	1
0	0	1	1	2
0	1	0	1	3
0	1	1	1	4
1	0	0	1	5
1	0	1	1	6
1	1	0	1	7
1	1	1	1	8

LOGIC 0 $V_{AL} \leq +0.8V$, LOGIC 1 $V_{AH} \geq +2.4V$

MAXIM
MAX4709

MAX4709			
A1	A0	EN	ON SWITCH
X	X	0	NONE
0	0	1	1
0	1	1	2
1	0	1	3
1	1	1	4

LOGIC 0 $V_{AL} \leq +0.8V$, LOGIC 1 $V_{AH} \geq +2.4V$

Fault-Protected, Single 8-to-1/ Dual 4-to-1 Multiplexers

Revision History

REVISION NUMBER	REVISION DATE	DESCRIPTION	PAGES CHANGED
0	9/02	Initial release	—
1	12/08	Added chip process and packaging information; changed fault conditions information	10, 11

MAX4708/MAX4709

Maxim cannot assume responsibility for use of any circuitry other than circuitry entirely embodied in a Maxim product. No circuit patent licenses are implied. Maxim reserves the right to change the circuitry and specifications without notice at any time.

Maxim Integrated Products, 120 San Gabriel Drive, Sunnyvale, CA 94086 408-737-7600 _____ 15

Looking for pricing, stock, or lifecycle information?

Click below to explore more details on WIN SOURCE:

 [View MAX4709ESE+ on WIN SOURCE](#)

 [Maxim Integrated](#) Information

Optimize Your Supply Chain with WIN SOURCE Solutions

-  Global Sourcing Solution
-  Obsolete Management
-  Cost Control Management
-  Shortage Management
-  Alternative Solution
-  Excess Inventory Management