



**THE DATASHEET OF  
MAX34462EXQ+**



**MAX34462****PMBus 16-Channel Monitor/Sequencer with Differential Inputs and Margining DACs****General Description**

The MAX34462 is a system monitor that can manage up to 16 power supplies. The power-supply manager monitors the power-supply output voltages and constantly checks for user-programmable overvoltage and undervoltage thresholds. If a fault is detected, the device automatically shuts down the system in an orderly fashion. The device can sequence the supplies in any order at both power-up and power-down. The device contains 16 independent voltages DACs, which the device uses to close-loop margin the power-supply output voltages up or down to a user-programmable level. The device contains an internal temperature sensor and can support up to four external remote temperature sensors. Once configured, the device can operate autonomously without any host intervention.

**Applications**

- Network Switches/Routers
- Base Stations
- Servers
- Smart Grid Network Systems

***Ordering Information and Typical Operating Circuit appear at end of data sheet.***

For related parts and recommended products to use with this part, refer to [www.maximintegrated.com/MAX34462.related](http://www.maximintegrated.com/MAX34462.related).

**Benefits and Features**

- 16 Channels of Power-Supply Management
- Power-Supply Voltage or Current Measurement and Monitoring
- Fast Minimum/Maximum Threshold Excursion Detection
- Differential Input Sensing Improves Measurement Accuracy
- 16 Independent Voltage DACs for Power-Supply Margining
- Automatic Closed-Loop Margining
- Programmable Up and Down Sequencing
- Up to Four Independent Sequencing Loops
- 5V Tolerant Power-Supply Output Enables
- Internal Temperature Sensor
- Reports Peak and Average Levels for a Number of Parameters
- PMBus™-Compliant Command Interface
- I<sup>2</sup>C/SMBus-Compatible Serial Bus with Bus Timeout Function
- On-Board Nonvolatile Black Box Fault Logging and Default Configuration Setting
- Expandable Channel Operation with Parallel Devices
- Sequencing Can be Timing Synchronized Across Multiple Devices
- Configurable Combinatorial Logic Supporting Up to 16 GPIs and 36 GPOs
- No External Clocking Required
- +3.0 to +3.6V Supply Voltage

PMBus is a trademark of SMIF, Inc.



---

**TABLE OF CONTENTS**

---

General Description . . . . .	1
Applications . . . . .	1
Benefits and Features . . . . .	1
Absolute Maximum Ratings . . . . .	8
Recommended Operating Conditions . . . . .	8
Electrical Characteristics . . . . .	9
I <sup>2</sup> C/SMBus Interface Electrical Specifications . . . . .	11
I <sup>2</sup> C/SMBus Timing . . . . .	11
Typical Operating Characteristics . . . . .	12
Bump Configuration . . . . .	14
Bump Description . . . . .	15
Expanded Bump Description . . . . .	20
CSBGA Bump Map . . . . .	20
Block Diagram . . . . .	21
Detailed Description . . . . .	22
PMBus/SMBus Address Select . . . . .	26
SMBus/PMBus Operation . . . . .	26
SMBus/PMBus Operation Examples . . . . .	27
Group Command . . . . .	28
Group Command Write Format . . . . .	28
Addressing . . . . .	28
ALERT and Alert Response Address (ARA) . . . . .	28
Host Sends or Reads Too Few Bits . . . . .	28
Host Sends or Reads Too Few Bytes . . . . .	29
Host Sends Too Many Bytes or Bits . . . . .	29
Host Reads Too Many Bytes or Bits . . . . .	29
Host Sends Improperly Set Read Bit in the Slave Address Byte . . . . .	29
Unsupported Command Code Received/Host Writes to a Read-Only Command . . . . .	29
Invalid Data Received . . . . .	29
Host Reads from a Write-Only Command . . . . .	29
SMBus Timeout . . . . .	29
PMBus Operation . . . . .	29
PMBus Protocol Support . . . . .	30
Data Format . . . . .	31
Interpreting Received DIRECT Format Values . . . . .	31
Sending a DIRECT Format Value . . . . .	31
Fault Management and Reporting . . . . .	31

**TABLE OF CONTENTS (continued)**

Password Protection . . . . .	32
Power-Supply Sequencing . . . . .	32
Quad-Loop Sequencing . . . . .	33
Power-On Sequencing . . . . .	34
Power-Off Sequencing . . . . .	34
Sequencing Example . . . . .	34
Multiple Device Connections . . . . .	35
$\overline{\text{SEQ}}$ Pin Operation . . . . .	37
SYNC Pin Operation . . . . .	37
System Watchdog Timer . . . . .	37
CRC Memory Check . . . . .	37
PMBus Commands . . . . .	37
PAGE (00h) . . . . .	37
OPERATION (01h) . . . . .	39
ON_OFF_CONFIG (02h) . . . . .	41
CLEAR_FAULTS (03h) . . . . .	42
WRITE_PROTECT (10h) . . . . .	42
Device Configuration Data Management . . . . .	42
STORE_DEFAULT_ALL (11h) . . . . .	43
RESTORE_DEFAULT_ALL (12h) . . . . .	43
MFR_STORE_ALL (EEh) . . . . .	44
MFR_RESTORE_ALL (EFh) . . . . .	44
MFR_STORE_SINGLE (FCh) . . . . .	44
MFR_CRC (FEh) . . . . .	45
CAPABILITY (19h) . . . . .	45
VOUT_MODE (20h) . . . . .	45
VOUT_COMMAND (21h) . . . . .	45
VOUT_MARGIN_HIGH (25h) . . . . .	46
VOUT_MARGIN_LOW (26h) . . . . .	46
VOUT_SCALE_MONITOR (2Ah) . . . . .	46
IOUT_CAL_GAIN (38h) . . . . .	47
VOUT_OV_FAULT_LIMIT (40h) . . . . .	47
VOUT_OV_WARN_LIMIT (42h) . . . . .	47
VOUT_UV_WARN_LIMIT (43h) . . . . .	47
VOUT_UV_FAULT_LIMIT (44h) . . . . .	47
IOUT_OC_WARN_LIMIT (46h) . . . . .	47
IOUT_OC_FAULT_LIMIT (4Ah) . . . . .	48
OT_FAULT_LIMIT (4Fh) . . . . .	48

**TABLE OF CONTENTS (continued)**

OT_WARN_LIMIT (51h) .....	48
POWER_GOOD_ON (5Eh) .....	48
POWER_GOOD_OFF (5Fh).....	48
TON_DELAY (60h) .....	48
TOFF_DELAY (64h) .....	48
TON_MAX_FAULT_LIMIT (62h).....	49
STATUS_WORD (79h) .....	49
STATUS_VOUT (7Ah).....	51
STATUS_IOUT (7Bh) .....	51
STATUS_TEMPERATURE (7Dh) .....	51
STATUS_CML (7Eh).....	52
STATUS_MFR_SPECIFIC (80h) .....	52
READ_VOUT (8Bh).....	53
READ_IOUT (8Ch) .....	53
READ_TEMPERATURE_1 (8Dh).....	53
PMBUS_REVISION (98h).....	53
MFR_ID (99h) .....	53
MFR_MODEL (9Ah) .....	53
MFR_REVISION (9Bh).....	53
MFR_LOCATION (9Ch) .....	53
MFR_DATE (9Dh).....	54
MFR_SERIAL (9Eh) .....	54
MFR_MODE (D1h) .....	54
MFR_PSEN_CONFIG (D2h) .....	55
Delay Function .....	56
MFR_VOUT_PEAK (D4h).....	57
MFR_IOUT_PEAK (D5h) .....	57
MFR_TEMPERATURE_PEAK (D6h) .....	57
MFR_VOUT_MIN (D7h) .....	57
MFR_IOUT_AVG (E2h).....	57
MFR_NV_LOG_CONFIG (D8h) .....	57
MFR_FAULT_RESPONSE (D9h).....	58
LOCAL vs. GLOBAL Channels .....	58
GLOBAL Channels Respond to FAULT Assertion .....	59
Temperature Fault Response.....	59
Fault Detection Before Power-On Sequencing .....	59
Logging Faults into MFR_NV_FAULT_LOG .....	59
Alarm Output Functionality .....	62

**TABLE OF CONTENTS (continued)**

MFR_FAULT_RETRY (DAh) . . . . .	63
MFR_NV_FAULT_LOG (DCh) . . . . .	63
MFR_TIME_COUNT (DDh) . . . . .	65
MFR_CHANNEL_CONFIG (E4h) . . . . .	65
MFR_TON_SEQ_MAX (E6h) . . . . .	68
MFR_SEQ_CONFIG (E8h) . . . . .	68
MFR_DAC_CONFIG (E9h) . . . . .	68
Delay Function . . . . .	71
MFR_MARGIN_CONFIG (DFh) . . . . .	71
Power-Supply Margining Operation . . . . .	71
Margining Faults . . . . .	72
DAC Value . . . . .	72
DAC Margining Component Selection . . . . .	72
Temperature Sensor Operation . . . . .	72
MFR_TEMP_SENSOR_CONFIG (F0h) . . . . .	73
MFR_GPO_CONFIG (F8h) . . . . .	73
Delay Function . . . . .	75
Applications Information . . . . .	75
DVDD, AVDD, VREF, and REG18 Decoupling . . . . .	75
Open-Drain Pins . . . . .	75
Keep-Alive Circuit . . . . .	75
Configuration Port . . . . .	75
Resistor-Dividers and Source Impedance for RS Inputs . . . . .	75
Protecting Input Pins . . . . .	75
Typical Operating Circuit . . . . .	76
Ordering Information . . . . .	77
Package Information . . . . .	77
Revision History . . . . .	78

---

**LIST OF FIGURES**

---

Figure 1. PMBus/SMBus Address Select . . . . .	26
Figure 2. Sequence Control Logic . . . . .	33
Figure 3. Sequencing Example . . . . .	35
Figure 4. Multiple MAX34462 Hardware Connections . . . . .	36
Figure 5. ON_OFF_CONFIG Logical Control . . . . .	41
Figure 6. Device Configuration Data Management . . . . .	42
Figure 7. Status Register Organization . . . . .	50
Figure 8. MFR_PSEN_CONFIG Functional Logic. . . . .	56
Figure 9. Input to Output Delay Action. . . . .	56
Figure 10. MFR_FAULT_RESPONSE Operation . . . . .	61
Figure 11. MFR_NV_FAULT_LOG . . . . .	63
Figure 12. MFR_CHANNEL_CONFIG Command. . . . .	67
Figure 13. MFR_DAC_CONFIG Functional Logic. . . . .	71
Figure 14. Margining Hardware Configurations . . . . .	72
Figure 15. MFR_GPO_CONFIG Functional Logic. . . . .	75

---

**LIST OF TABLES**

---

Table 1. PMBus PAGE to Pin/Resource Mapping . . . . .	22
Table 2. Device Channel Capabilities and Options . . . . .	23
Table 3. PMBus Command Codes. . . . .	23
Table 4. PMBus/SMBus Serial Port Address. . . . .	26
Table 5. PMBus Command Code Coefficients . . . . .	30
Table 6. Coefficients for DIRECT Format Value . . . . .	31
Table 7. Fault-Monitoring States . . . . .	32
Table 8. OPERATION Command Sequence Control Options. . . . .	33
Table 9. PAGE (00h) Commands. . . . .	38
Table 10. OPERATION (01h) Command Byte with PAGE = 0 to 15 (When Bit 3 of ON_OFF_CONFIG = 1) . . . . .	39
Table 11. OPERATION (01h) Command Byte with PAGE = 255 (When Bit 3 of ON_OFF_CONFIG = 1) . . . . .	40
Table 12. OPERATION (01h) Command Byte (When Bit 3 of ON_OFF_CONFIG = 0) . . . . .	40
Table 13. ON_OFF_CONFIG (02h) Command Byte . . . . .	41
Table 14. WRITE_PROTECT (10h) Command Byte . . . . .	42
Table 15. Memory Transfer PMBus Commands . . . . .	43
Table 16. MFR_CRC (FEh) Command Byte . . . . .	45
Table 17. CAPABILITY (19h) Command Byte . . . . .	45
Table 18. VOUT_SCALE_MONITOR (2Ah) Examples . . . . .	46
Table 19. STATUS_WORD (79h) . . . . .	49

**LIST OF TABLES (continued)**

Table 20. STATUS_VOUT (7Ah) .....	51
Table 21. STATUS_IOUT (7Bh) .....	51
Table 22. STATUS_TEMPERATURE (7Dh) .....	51
Table 23. STATUS_CML (7Eh) .....	52
Table 24. STATUS_MFR_SPECIFIC (80h) (for PAGES 0 to 15) .....	52
Table 25. STATUS_MFR_SPECIFIC (80h) (for PAGE 255) .....	53
Table 26. MFR_MODE (D1h) .....	54
Table 27. MFR_PSEN_CONFIG (D2h) .....	55
Table 28. MFR_NV_LOG_CONFIG (D8h) .....	57
Table 29. Fault-Monitoring States .....	59
Table 30. MFR_FAULT_RESPONSE (D9h) .....	60
Table 31. ALARM_CONFIG Codes .....	61
Table 32. MFR_FAULT_RESPONSE Codes for GLOBAL Channels .....	62
Table 33. MFR_FAULT_RESPONSE Codes for LOCAL Channels .....	62
Table 34. MFR_NV_FAULT_LOG (DCh) .....	64
Table 35. MFR_CHANNEL_CONFIG (E4h) .....	66
Table 36. MFR_SEQ_CONFIG (E8h) .....	69
Table 37. MFR_DAC_CONFIG (E9h) .....	70
Table 38. MFR_MARGIN_CONFIG (DFh) .....	71
Table 39. DS75LV Address Pin Configuration .....	73
Table 40. MFR_TEMP_SENSOR_CONFIG (F0h) .....	73
Table 41. GPO Description .....	73
Table 42. MFR_GPO_CONFIG (F8h) .....	74

**Absolute Maximum Ratings**

DVDD/AVDD to DVSS/AVSS .....-0.3V to +4.0V  
 RSN/GPIN to AVSS.....-0.3V to +0.3V  
 PSEN to DVSS.....-0.3V to +5.5V  
 All Other Pins (except REG18 and REG18A)  
 Relative to DVSS/AVSS ..... -0.3V to (V<sub>DVDD</sub>/V<sub>AVDD</sub> + 0.3V)\*  
 REG18 and REG18A to AVSS .....-0.3V to +2.0V

Continuous Power Dissipation (T<sub>A</sub> = +70°C)  
 CSBGA (derate 40mW/°C above +70°C) .....2200mW  
 Operating Temperature Range.....-40°C to +95°C  
 Storage Temperature Range .....-55°C to +125°C  
 Soldering Temperature (reflow).....+260°C

\*Subject to not exceeding +4.0V.

Stresses beyond those listed under "Absolute Maximum Ratings" may cause permanent damage to the device. These are stress ratings only, and functional operation of the device at these or any other conditions beyond those indicated in the operational sections of the specifications is not implied. Exposure to absolute maximum rating conditions for extended periods may affect device reliability.

**Recommended Operating Conditions**

(T<sub>A</sub> = -40°C to +95°C, unless otherwise noted.)

PARAMETER	SYMBOL	CONDITIONS	MIN	TYP	MAX	UNITS
Operating Voltage Range	V <sub>DVDD</sub> , V <sub>AVDD</sub>	(Note 1)	3.0		3.6	V
V <sub>DD</sub> Rise Time		From 0 to 2.5V			4	ms
V <sub>DD</sub> Source Impedance					10	Ω
Input Logic 1 (except I <sup>2</sup> C and GPI Pins)	V <sub>IH1</sub>		0.7 x V <sub>DD</sub>		V <sub>DD</sub> + 0.3	V
Input Logic 0 (except I <sup>2</sup> C and GPI Pins)	V <sub>IL1</sub>		-0.3		+0.3 x V <sub>DD</sub>	V
Input Logic 1: SCL, SDA, MSCL, MSDA	V <sub>IH2</sub>		2.1		V <sub>DD</sub> + 0.3	V
Input Logic 0: SCL, SDA, MSCL, MSDA	V <sub>IL2</sub>		-0.3		+0.8	V
Input Logic 1 (GPI Pins)	V <sub>IH3</sub>	Minimum pulse width = 5ms	1.5		V <sub>DD</sub> + 0.3	V
Input Logic 0 (GPI Pins)	V <sub>IL3</sub>	Minimum pulse width = 5ms	-0.3		+1.0	V
Source Impedance to RS		ADC_TIME[1:0] = 00			1	kΩ
		ADC_TIME[1:0] = 01			5	
		ADC_TIME[1:0] = 10			10	
		ADC_TIME[1:0] = 11			20	
DAC Output Capacitance Load		In series with > 5kΩ			50	nF

## Electrical Characteristics

( $V_{DVDD}$  and  $V_{AVDD}$  = 3.0V to 3.6V,  $T_A$  = -40°C to +95°C, unless otherwise noted. Typical values are at  $V_{DVDD}/V_{AVDD}$  = 3.3V,  $T_A$  = +25°C.)

PARAMETER	SYMBOL	CONDITIONS	MIN	TYP	MAX	UNITS
<b>GENERAL</b>						
Supply Current	$I_{CPU}$	(Note 2)		13		mA
	$I_{PROGRAM}$			16		
System Clock Error	$f_{ERR:MOSC}$	+25°C < $T_A$ < +95°C	-3		+3	%
		-40°C < $T_A$ < 25°C	-4		+4	
Output Logic-Low (except I <sup>2</sup> C Pins)	$V_{OL1}$	$I_{OL} = 4mA$ (Note 1)			0.4	V
Output Logic-High (except I <sup>2</sup> C Pins)	$V_{OH1}$	$I_{OH} = -2mA$ (Note 1)	$V_{DVDD}$ - 0.5			V
Output Logic-Low: SCL, SDA, MSCL, MSDA	$V_{OL2}$	$I_{OL} = 4mA$ (Note 1)			0.4	V
SCL, SDA, MSCL, MSDA Leakage	$I_{I2C}$	$V_{DVDD} = 0V$ or float			±5	µA
CONTROL0 Threshold				2.048		V
CONTROL0 Hysteresis				50		mV
<b>ADC</b>						
ADC Bit Resolution				12		Bits
ADC Conversion Time		ADC_TIME[1:0] = 00		1000		ns
ADC Full Scale	$V_{FS}$	$T_A = 0°C$ to +95°C	2.032	2.048	2.064	V
ADC Measurement Resolution	$V_{LSB}$			500		µV
RS Input Capacitance	$C_{RS}$			15		pF
RS Input Leakage	$I_{LRS}$	$0V < V_{RS} < V_{AVDD}$		±0.25		µA
ADC Integral Nonlinearity	INL			±1		LSB
ADC Differential Nonlinearity	DNL			±1		LSB
<b>DAC</b>						
DAC Resolution				8		Bits
DAC Full-Scale Accuracy		$0°C \leq T_A \leq +95°C$	2.0	2.048	2.1	V
DAC Integral Nonlinearity					±2	LSB
DAC Differential Nonlinearity					±1	LSB
DAC Offset Error					±25	mV
DAC Load Regulation	DAC <sub>LDREG500</sub>	$V_{DACOUT} > 200mV$ , 500µA sink and source	-8		+8	mV
	DAC <sub>LDREG200</sub>	$V_{DACOUT} > 100mV$ , 200µA sink and source	-5		+5	
Output Short Circuit				5		mA
Output Leakage		Output disabled			±1	µA

**Electrical Characteristics (continued)**

( $V_{DVDD}$  and  $V_{AVDD}$  = 3.0V to 3.6V,  $T_A$  = -40°C to +95°C, unless otherwise noted. Typical values are at  $V_{DVDD}/V_{AVDD}$  = 3.3V,  $T_A$  = +25°C.)

PARAMETER	SYMBOL	CONDITIONS	MIN	TYP	MAX	UNITS
<b>TEMPERATURE SENSOR</b>						
Internal Temperature Measurement Error		$T_A$ = -40°C to +95°C		±2		°C
<b>FLASH</b>						
Flash Endurance	$N_{FLASH}$	(Note 3)	20,000			Write Cycles
Data Retention		$T_A$ = +50°C (Note 3)	100			Years
STORE_DEFAULT_ALL MFR_STORE_ALL Write Time				85		ms
MFR_STORE_SINGLE Write Time				310		µs
RESTORE_DEFAULT_ALL MFR_RESTORE_ALL Time		With MFR_STORE_SINGLE data		110		ms
		Without MFR_STORE_SINGLE data		1.2		
MFR_NV_FAULT_LOG Write Time		Writing one fault log		11		ms
MFR_NV_FAULT_LOG Delete Time		Deleting all fault logs		200		ms
MFR_NV_FAULT_LOG Overwrite Time				40		ms
<b>TIMING OPERATING CHARACTERISTICS</b>						
Round-Robin Voltage and Current Sample Rate		Threshold excursion (Note 4)		64		µs
		Data collection		5		ms
Temperature Sample Rate				1000		ms
Device Startup Time		With MFR_STORE_SINGLE data		170		ms
		Without MFR_STORE_SINGLE data		90		
SYNC Clock Frequency				20		kHz

**Note 1:** All voltages are reference to ground. Currents entering the IC are specified as positive and currents exiting the IC are negative.

**Note 2:** This does not include pin input/output currents.

**Note 3:** Guaranteed by design.

**Note 4:** The round-robin threshold excursion rate can be changed with the ADC\_AVERAGE and ADC\_TIME bits in MFR\_MODE from 16µs (no averaging and 1µs conversion) to 1024µs (8x averaging and 8µs conversion).

### I<sup>2</sup>C/SMBus Interface Electrical Specifications

(V<sub>DVDD</sub> and V<sub>AVDD</sub> = 3.0V to 3.6V, T<sub>A</sub> = -40°C to +95°C, unless otherwise noted. Typical values are at V<sub>DVDD</sub>/V<sub>AVDD</sub> = 3.3V, T<sub>A</sub> = +25°C.)

PARAMETER	SYMBOL	CONDITIONS	MIN	TYP	MAX	UNITS
SCL Clock Frequency	f <sub>SCL</sub>		10		400	kHz
MSCL Clock Frequency	f <sub>MSCL</sub>			100		kHz
Bus Free Time Between STOP and START Conditions	t <sub>BUF</sub>		1.3			μs
Hold Time (Repeated) START Condition	t <sub>HD:STA</sub>		0.6			μs
Low Period of SCL	t <sub>LOW</sub>		1.3			μs
High Period of SCL	t <sub>HIGH</sub>		0.6			μs
Data Hold Time	t <sub>HD:DAT</sub>	Receive	0			ns
		Transmit	300			
Data Set-Up Time	t <sub>SU:DAT</sub>		100			ns
START Set-Up Time	t <sub>SU:STA</sub>		0.6			μs
SDA and SCL Rise Time	t <sub>R</sub>				300	ns
SDA and SCL Fall Time	t <sub>F</sub>				300	ns
STOP Set-Up Time	t <sub>SU:STO</sub>		0.6			μs
Clock Low Timeout	t <sub>TO</sub>		25	27	35	ms

### I<sup>2</sup>C/SMBus Timing

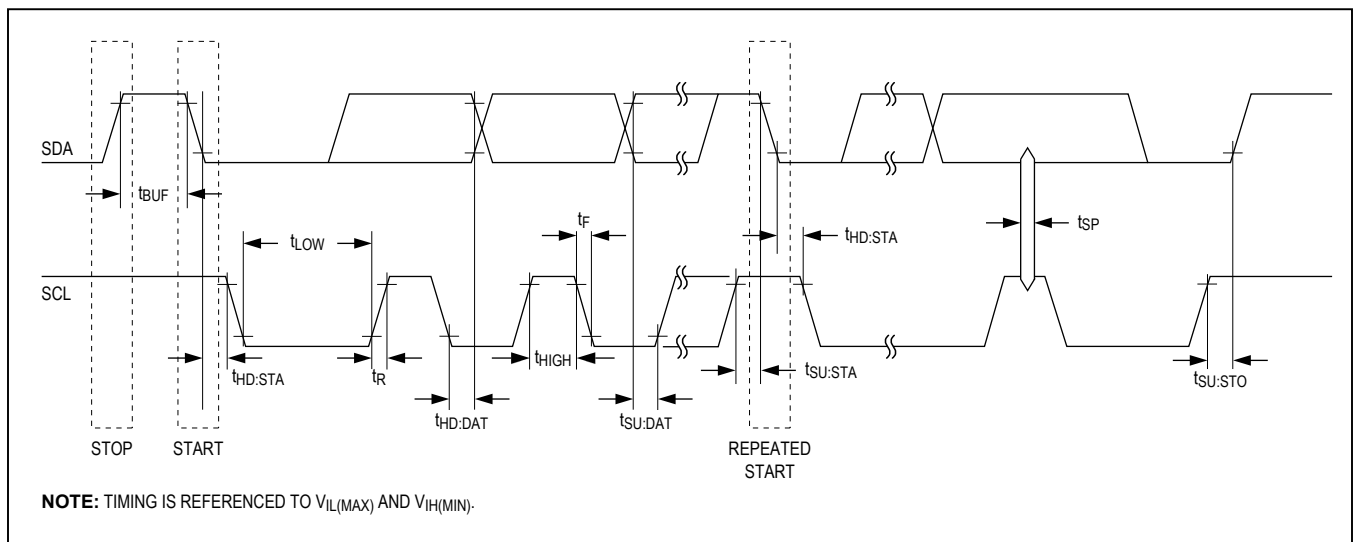

Typical Operating Characteristics

( $V_{DD}$  and  $V_{AVDD} = 3.3V$  and  $T_A = +25^\circ C$ , without MFR\_STORE\_SINGLE data, unless otherwise noted.)

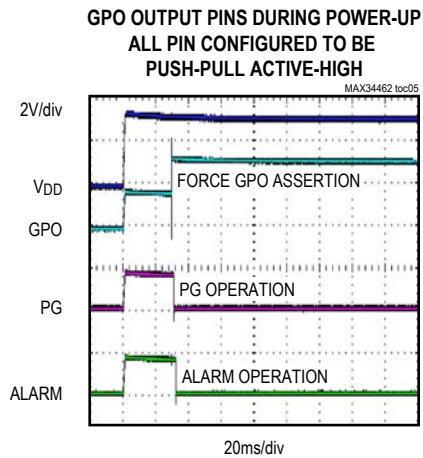
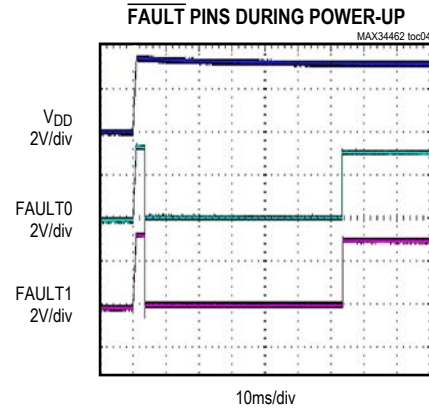
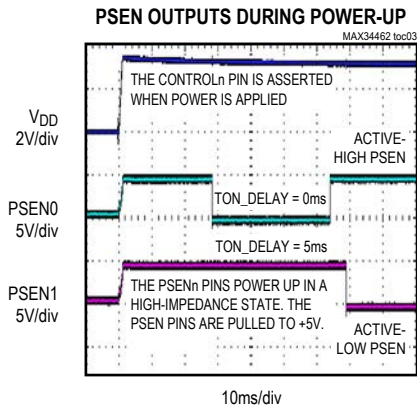
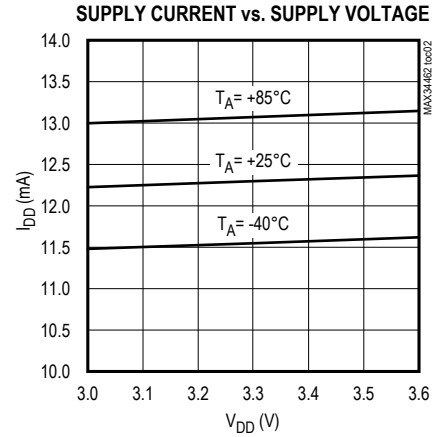
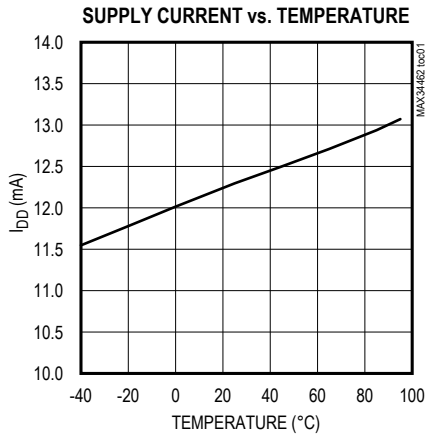

Typical Operating Characteristics (continued)

( $V_{DD}$  and  $V_{AVDD}$  = 3.3V and  $T_A$  = +25°C, without MFR\_STORE\_SINGLE data, unless otherwise noted.)

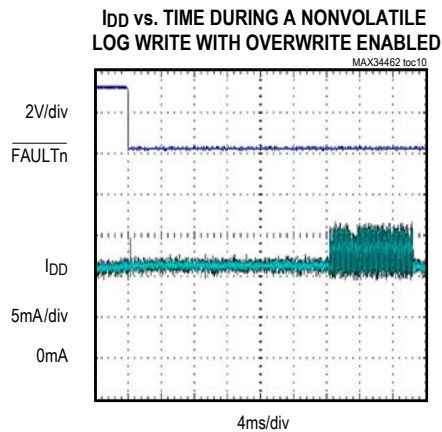
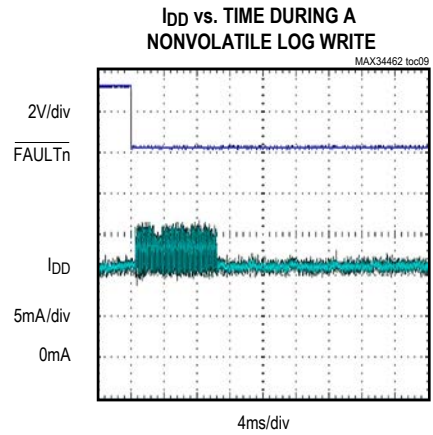
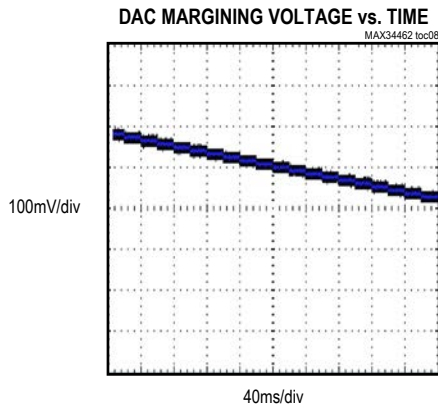
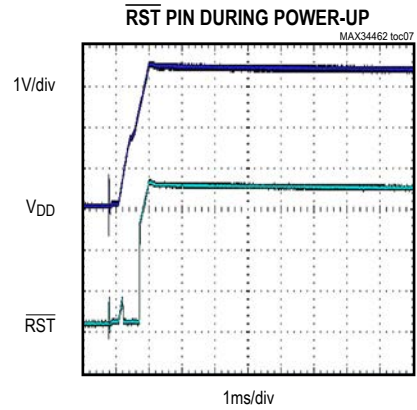
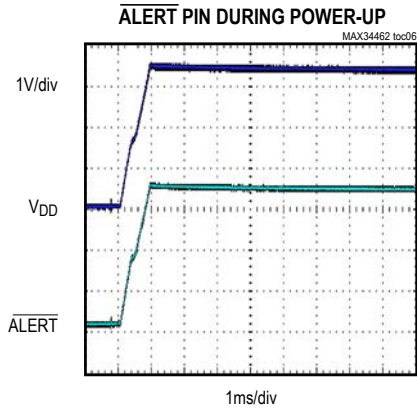

Bump Configuration



## Bump Description

BUMP	NAME	TYPE	FUNCTION
A1	RSP0	AI	ADC Voltage Sense Positive Input 0. Connect to AVSS if unused.
	GPIP0	AI	General-Purpose Positive Input 0. Connect to AVSS if unused.
A2	RSN0	AI	ADC Voltage Sense Negative Input 0. Connect to AVSS if unused.
	GPIN0	AI	General-Purpose Negative Input 0. Connect to AVSS if unused.
B2	RSP1	AI	ADC Voltage Sense Positive Input 1. Connect to AVSS if unused.
	GPIP1	AI	General-Purpose Positive Input 1. Connect to AVSS if unused.
B1	RSN1	AI	ADC Voltage Sense Negative Input 1. Connect to AVSS if unused.
	GPIN1	AI	General-Purpose Negative Input 1. Connect to AVSS if unused.
C2	RSP2	AI	ADC Voltage Sense Positive Input 2. Connect to AVSS if unused.
	GPIP2	AI	General-Purpose Positive Input 2. Connect to AVSS if unused.
C1	RSN2	AI	ADC Voltage Sense Negative Input 2. Connect to AVSS if unused.
	GPIN2	AI	General-Purpose Negative Input 2. Connect to AVSS if unused.
D2	RSP3	AI	ADC Voltage Sense Positive Input 3. Connect to AVSS if unused.
	GPIP3	AI	General-Purpose Positive Input 3. Connect to AVSS if unused.
D1	RSN3	AI	ADC Voltage Sense Negative Input 3. Connect to AVSS if unused.
	GPIN3	AI	General-Purpose Negative Input 3. Connect to AVSS if unused.
E1	RSP4	AI	ADC Voltage Sense Positive Input 4. Connect to AVSS if unused.
	GPIP4	AI	General-Purpose Positive Input 4. Connect to AVSS if unused.
E2	RSN4	AI	ADC Voltage Sense Negative Input 4. Connect to AVSS if unused.
	GPIN4	AI	General-Purpose Negative Input 4. Connect to AVSS if unused.
F1	RSP5	AI	ADC Voltage Sense Positive Input 5. Connect to AVSS if unused.
	GPIP5	AI	General-Purpose Positive Input 5. Connect to AVSS if unused.
F2	RSN5	AI	ADC Voltage Sense Negative Input 5. Connect to AVSS if unused.
	GPIN5	AI	General-Purpose Negative Input 5. Connect to AVSS if unused.
G1	RSP6	AI	ADC Voltage Sense Positive Input 6. Connect to AVSS if unused.
	GPIP6	AI	General-Purpose Positive Input 6. Connect to AVSS if unused.
G2	RSN6	AI	ADC Voltage Sense Negative Input 6. Connect to AVSS if unused.
	GPIN6	AI	General-Purpose Negative Input 6. Connect to AVSS if unused.
H1	RSP7	AI	ADC Voltage Sense Positive Input 7. Connect to AVSS if unused.
	GPIP7	AI	General-Purpose Positive Input 7. Connect to AVSS if unused.
H2	RSN7	AI	ADC Voltage Sense Negative Input 7. Connect to AVSS if unused.
	GPIN7	AI	General-Purpose Negative Input 7. Connect to AVSS if unused.
J1	RSP8	AI	ADC Voltage Sense Positive Input 8. Connect to AVSS if unused.
	GPIP8	AI	General-Purpose Positive Input 8. Connect to AVSS if unused.
J2	RSN8	AI	ADC Voltage Sense Negative Input 8. Connect to AVSS if unused.
	GPIN8	AI	General-Purpose Negative Input 8. Connect to AVSS if unused.
K1	RSP9	AI	ADC Voltage Sense Positive Input 9. Connect to AVSS if unused.
	GPIP9	AI	General-Purpose Positive Input 9. Connect to AVSS if unused.
K2	RSN9	AI	ADC Voltage Sense Negative Input 9. Connect to AVSS if unused.
	GPIN9	AI	General-Purpose Negative Input 9. Connect to AVSS if unused.
K3	RSP10	AI	ADC Voltage Sense Positive Input 10. Connect to AVSS if unused.
	GPIP10	AI	General-Purpose Positive Input 10. Connect to AVSS if unused.

## Bump Description (continued)

BUMP	NAME	TYPE	FUNCTION
J3	RSN10	AI	ADC Voltage Sense Negative Input 10. Connect to AVSS if unused.
	GPIN10	AI	General-Purpose Negative Input 10. Connect to AVSS if unused.
H3	RSP11	AI	ADC Voltage Sense Positive Input 11. Connect to AVSS if unused.
	GPIP11	AI	General-Purpose Positive Input 11. Connect to AVSS if unused.
H4	RSN11	AI	ADC Voltage Sense Negative Input 11. Connect to AVSS if unused.
	GPIN11	AI	General-Purpose Negative Input 11. Connect to AVSS if unused.
A3	RSP12	AI	ADC Voltage Sense Positive Input 12. Connect to AVSS if unused.
	GPIP12	AI	General-Purpose Positive Input 12. Connect to AVSS if unused.
B3	RSN12	AI	ADC Voltage Sense Negative Input 12. Connect to AVSS if unused.
	GPIN12	AI	General-Purpose Negative Input 12. Connect to AVSS if unused.
A4	RSP13	AI	ADC Voltage Sense Positive Input 13. Connect to AVSS if unused.
	GPIP13	AI	General-Purpose Positive Input 13. Connect to AVSS if unused.
B4	RSN13	AI	ADC Voltage Sense Negative Input 13. Connect to AVSS if unused.
	GPIN13	AI	General-Purpose Negative Input 13. Connect to AVSS if unused.
K4	RSP14	AI	ADC Voltage Sense Positive Input 14. Connect to AVSS if unused.
	GPIP14	AI	General-Purpose Positive Input 14. Connect to AVSS if unused.
J4	RSN14	AI	ADC Voltage Sense Negative Input 14. Connect to AVSS if unused.
	GPIN14	AI	General-Purpose Negative Input 14. Connect to AVSS if unused.
K5	RSP15	AI	ADC Voltage Sense Positive Input 15. Connect to AVSS if unused.
	GPIP15	AI	General-Purpose Positive Input 15. Connect to AVSS if unused.
J5	RSN15	AI	ADC Voltage Sense Negative Input 15. Connect to AVSS if unused.
	GPIN15	AI	General-Purpose Negative Input 15. Connect to AVSS if unused.
C10	RST	DIO	Reset Active-Low Input/Output. Contains an internal pullup.
G4	CONTROL0	AI	Power-Supply Master On/Off Control Input 0. Active-low or active-high based on ON_OFF_CONFIG command. Connect to AVSS if unused. A series 100Ω resistor is recommended if this input can be driven when the device is powered down.
K8	CONTROL1	DI	Power-Supply Master On/Off Control Input 1. Active-low or active-high based on ON_OFF_CONFIG command. Connect to DVSS if unused. A series 100Ω resistor is recommended if this input can be driven when the device is powered down.
H8	CONTROL2	DI	Power-Supply Master On/Off Control Input 2. Active-low or active-high based on ON_OFF_CONFIG command. Connect to DVSS if unused. A series 100Ω resistor is recommended if this input can be driven when the device is powered down.
J8	CONTROL3	DI	Power-Supply Master On/Off Control Input 3. Active-low or active-high based on ON_OFF_CONFIG command. Connect to DVSS if unused. A series 100Ω resistor is recommended if this input can be driven when the device is powered down.
E5	GPO33	DO	General-Purpose Output 33. Function is selected using the MFR_GPO_CONFIG command.
D7	SEQ	DIO	Sequencing Input/Output. Open-drain, active low. This pin is used as handshake signal to coordinate event-based sequencing in systems using multiple devices.
	GPO32	DO	General-Purpose Output 32. Function is selected using the MFR_GPO_CONFIG command.
D8	SDA	DIO	I <sup>2</sup> C/SMBus-Compatible Input/Output. Open-drain output.
D9	SCL	DIO	I <sup>2</sup> C/SMBus-Compatible Clock Input/Output. Open-drain output.

## Bump Description (continued)

BUMP	NAME	TYPE	FUNCTION
C8	MSCL	DIO	Master I <sup>2</sup> C Clock Input/Output. Open-drain output.
C9	MSDA	DIO	Master I <sup>2</sup> C Data Input/Output. Open-drain output.
H10	$\overline{\text{ALERT}}$	DO	Alert Output. Open-drain, active-low output.
E9	ADDR	DI	SMBus Slave Address Select. This pin is sampled on device power-up to determine the SMBus address. See the section on PMBus/SMBus address select for details on how to strap this pin to select the proper slave address.
E10	GPO34	DO	General-Purpose Output 34. Function is selected using the MFR_GPO_CONFIG command.
J9	$\overline{\text{FAULT0}}$	DIO	Fault Input/Output 0. Open-drain, active-low. See the <i>Expanded Bump Description</i> section for more details.
	GPO28	DO	General-Purpose Output 28. Function is selected using the MFR_GPO_CONFIG command.
K10	$\overline{\text{FAULT1}}$	DIO	Fault Input/Output 1. Open-drain, active-low. See the <i>Expanded Bump Description</i> section for more details.
	GPO29	DO	General-Purpose Output 29. Function is selected using the MFR_GPO_CONFIG command.
J10	$\overline{\text{FAULT2}}$	DIO	Fault Input/Output 2. Open-drain, active-low. See the <i>Expanded Bump Description</i> section for more details.
	GPO30	DO	General-Purpose Output 30. Function is selected using the MFR_GPO_CONFIG command.
H9	$\overline{\text{FAULT3}}$	DIO	Fault Input/Output 3. Open-drain, active-low. See the <i>Expanded Bump Description</i> for more details.
	GPO31	DO	General-Purpose Output 31. Function is selected using the MFR_GPO_CONFIG command.
G9	PSEN0	DO	Power-Supply Enable 0. See the <i>Expanded Bump Description</i> section for more details.
	GPO0	DO	General-Purpose Output 0
F8	PSEN1	DO	Power-Supply Enable 1. See the <i>Expanded Bump Description</i> section for more details.
	GPO1	DO	General-Purpose Output 1
G10	PSEN2	DO	Power-Supply Enable 2. See the <i>Expanded Bump Description</i> section for more details.
	GPO2	DO	General-Purpose Output 2
F7	PSEN3	DO	Power-Supply Enable 3. See the <i>Expanded Bump Description</i> section for more details.
	GPO3	DO	General-Purpose Output 3
F9	PSEN4	DO	Power-Supply Enable 4. See the <i>Expanded Bump Description</i> section for more details.
	GPO4	DO	General-Purpose Output 4
E8	PSEN5	DO	Power-Supply Enable 5. See the <i>Expanded Bump Description</i> section for more details.
	GPO5	DO	General-Purpose Output 5
F10	PSEN6	DO	Power-Supply Enable 6. See the <i>Expanded Bump Description</i> section for more details.
	GPO6	DO	General-Purpose Output 6
E7	PSEN7	DO	Power-Supply Enable 7. See the <i>Expanded Bump Description</i> section for more details.
	GPO7	DO	General-Purpose Output 7
H5	PSEN8	DO	Power-Supply Enable 8. See the <i>Expanded Bump Description</i> section for more details.
	GPO8	DO	General-Purpose Output 8

## Bump Description (continued)

BUMP	NAME	TYPE	FUNCTION
K7	PSEN9	DO	Power-Supply Enable 9. See the <i>Expanded Bump Description</i> section for more details.
	GPO9	DO	General-Purpose Output 9
F6	PSEN10	DO	Power-Supply Enable 10. See the <i>Expanded Bump Description</i> section for more details.
	GPO10	DO	General-Purpose Output 10
J6	PSEN11	DO	Power-Supply Enable 11. See the <i>Expanded Bump Description</i> section for more details.
	GPO11	DO	General-Purpose Output 11
H6	PSEN12	DO	Power-Supply Enable 12. See the <i>Expanded Bump Description</i> section for more details.
	GPO12	DO	General-Purpose Output 12
G6	PSEN13	DO	Power-Supply Enable 13. See the <i>Expanded Bump Description</i> section for more details.
	GPO13	DO	General-Purpose Output 13
J7	PSEN14	DO	Power-Supply Enable 14. See the <i>Expanded Bump Description</i> section for more details.
	GPO14	DO	General-Purpose Output 14
H7	PSEN15	DO	Power-Supply Enable 15. See the <i>Expanded Bump Description</i> section for more details.
	GPO15	DO	General-Purpose Output 15
A9	DAC0	AO	Margining DAC Output 0. See the <i>Expanded Bump Description</i> section for more details.
	GPO16	DO	General-Purpose Output 16
B8	DAC1	AO	Margining DAC Output 1. See the <i>Expanded Bump Description</i> section for more details.
	GPO17	DO	General-Purpose Output 17
A8	DAC2	AO	Margining DAC Output 2. See the <i>Expanded Bump Description</i> section for more details.
	GPO18	DO	General-Purpose Output 18
C7	DAC3	AO	Margining DAC Output 3. See the <i>Expanded Bump Description</i> section for more details.
	GPO19	DO	General-Purpose Output 19
A6	DAC4	AO	Margining DAC Output 4. See the <i>Expanded Bump Description</i> section for more details.
	GPO20	DO	General-Purpose Output 20
B6	DAC5	AO	Margining DAC Output 5. See the <i>Expanded Bump Description</i> section for more details.
	GPO21	DO	General-Purpose Output 21
C6	DAC6	AO	Margining DAC Output 6. See the <i>Expanded Bump Description</i> section for more details.
	GPO22	DO	General-Purpose Output 22
A5	DAC7	AO	Margining DAC Output 7. See the <i>Expanded Bump Description</i> section for more details.
	GPO23	DO	General-Purpose Output 23
D6	DAC8	AO	Margining DAC Output 8. See the <i>Expanded Bump Description</i> section for more details.
	GPO24	DO	General-Purpose Output 24
E4	DAC9	AO	Margining DAC Output 9. See the <i>Expanded Bump Description</i> section for more details.
	GPO25	DO	General-Purpose Output 25
D5	DAC10	AO	Margining DAC Output 10. See the <i>Expanded Bump Description</i> section for more details.
	GPO26	DO	General-Purpose Output 26
D4	DAC11	AO	Margining DAC Output 11. See the <i>Expanded Bump Description</i> section for more details.
	GPO27	DO	General-Purpose Output 27
D3	DAC12	AO	Margining DAC Output 12. See the <i>Expanded Bump Description</i> section for more details.
C3	DAC13	AO	Margining DAC Output 13. See the <i>Expanded Bump Description</i> section for more details.
C4	DAC14	AO	Margining DAC Output 14. See the <i>Expanded Bump Description</i> section for more details.
B5	DAC15	AO	Margining DAC Output 15. See the <i>Expanded Bump Description</i> section for more details.

## Bump Description (continued)

BUMP	NAME	TYPE	FUNCTION
D10	SYNC	DIO	Sequencing Synchronization Clock. This pin can be configured using the MFR_MODE command to be either an output (master mode) which provides a 20kHz clock or an input which accepts a 20kHz clock (slave mode) to share the same clock across multiple devices in order to synchronize the time base used for power-supply sequencing. A series 100Ω resistor is recommended to isolate outputs if two masters share the same bus. Leave open circuit if unused.
	GPO35	DO	General-Purpose Output 35. Function is selected using the MFR_GPO_CONFIG command.
F3	VREF	AO	Voltage Reference Output for Analog Circuitry. Bypass to AVSS with 22nF. Do not connect other circuitry to this pin.
B9	DVDD	Power	Digital Supply Voltage. Bypass to DVSS with 0.1μF. Connect all DVDD and AVDD pins together.
F5	DVDD	Power	Digital Supply Voltage. Bypass to DVSS with 0.1μF. Connect all DVDD and AVDD pins together.
G8	DVDD	Power	Digital Supply Voltage. Bypass to DVSS with 0.1μF. Connect all DVDD and AVDD pins together.
B10	DVSS	Power	Digital Supply Ground Reference. Connect all DVSS and AVSS pins together.
K9	DVSS	Power	Digital Supply Ground Reference. Connect all DVSS and AVSS pins together.
G7	DVSS	Power	Digital Supply Ground Reference. Connect all DVSS and AVSS pins together.
E6	DVSS	Power	Digital Supply Ground Reference. Connect all DVSS and AVSS pins together.
K6	DVSS	Power	Digital Supply Ground Reference. Connect all DVSS and AVSS pins together.
G5	REG18	Power	Regulator for Digital Circuitry. Bypass to AVSS with 1μF (500mΩ maximum ESR) and 10nF. Do not connect other circuitry to this pin.
A10	REG18A	Power	Supplemental Bypass for Regulator for Digital Circuitry. Bypass to AVSS with 0.1μF. Do not connect other circuitry to this pin.
B7	AVSS	Power	Analog Supply Ground Reference. Connect all DVSS and AVSS pins together.
C5	AVSS	Power	Analog Supply Ground Reference. Connect all DVSS and AVSS pins together.
G3	AVSS	Power	Analog Supply Ground Reference. Connect all DVSS and AVSS pins together.
F4	AVDD	Power	Analog Supply Voltage. Bypass to AVSS with 0.1μF. Connect all DVDD and AVDD pins together.
E3	AVDD	Power	Analog Supply Voltage. Bypass to AVSS with 0.1μF. Connect all DVDD and AVDD pins together.
A7	AVDD	Power	Analog Supply Voltage. Bypass to AVSS with 0.1μF. Connect all DVDD and AVDD pins together.

**Note:** All pins except the power pins and ADDR and GPO34 are high impedance during device power-up and during device reset.

DI = Digital Input, DO = Digital Output, DIO = Digital Input/Output, AI = Analog Input, AO = Analog Output

**Expanded Bump Description**

BUMP	EXPANDED DESCRIPTION
PSEN	The PSEN open-drain outputs are 5V tolerant and they are programmable with the MFR_PSEN_CONFIG command for either active-high or active-low operation. If not used for power-supply enables, these outputs can be repurposed as general purpose outputs (GPO) using the MFR_PSEN_CONFIG command. <i>If these pins are used to enable power supplies, it is <b>highly recommended</b> that these pins have external pullups or pulldowns to force the supplies into an off state when the device is not active.</i>
DAC	The DAC outputs are high-impedance when the margining is disabled. If DAC0 to DAC11 are not used for margining, these pins can be repurposed as a general purpose outputs (GPO) with the MFR_DAC_CONFIG command.
$\overline{\text{FAULT}}$	All $\overline{\text{FAULT}}$ pins operate independently. Any global channel can be enabled with the MFR_FAULT_RESPONSE command to assert one or more of the $\overline{\text{FAULT}}$ signals. Also each global channel can be enabled to shut down when one or more of the $\overline{\text{FAULT}}$ signals asserts. These pins are used to provide hardware control for power supplies across multiple devices. These outputs are unconditionally deasserted while RST is asserted or when the device is power cycled. After device reset and upon device power-up, these outputs are pulled low immediately after program recall and held low until monitoring starts. Once monitoring starts, the $\overline{\text{FAULT}}$ signals are released if no enabled faults are present.

**CSBGA Bump Map**

	1	2	3	4	5	6	7	8	9	10
A	RSP0	RSN0	RSP12	RSP13	DAC7	DAC4	AVDD	DAC2	DAC0	REG18A
B	RSN1	RSP1	RSN12	RSN13	DAC15	DAC5	AVSS	DAC1	DVDD	DVSS
C	RSN2	RSP2	DAC13	DAC14	AVSS	DAC6	DAC3	MSCL	MSDA	$\overline{\text{RST}}$
D	RSN3	RSP3	DAC12	DAC11	DAC10	DAC8	$\overline{\text{SEQ}}$	SDA	SCL	SYNC
E	RSP4	RSN4	AVDD	DAC9	GPO33	DVSS	PSEN7	PSEN5	ADDR	GPO34
F	RSP5	RSN5	VREF	AVDD	DVDD	PSEN10	PSEN3	PSEN1	PSEN4	PSEN6
G	RSP6	RSN6	AVSS	CONTROL0	REG18	PSEN13	DVSS	DVDD	PSEN0	PSEN2
H	RSP7	RSN7	RSP11	RSN11	PSEN8	PSEN12	PSEN15	CONTROL2	$\overline{\text{FAULT3}}$	$\overline{\text{ALERT}}$
J	RSP8	RSN8	RSN10	RSN14	RSN15	PSEN11	PSEN14	CONTROL3	$\overline{\text{FAULT0}}$	$\overline{\text{FAULT2}}$
K	RSP9	RSN9	RSP10	RSP14	RSP15	DVSS	PSEN9	CONTROL1	DVSS	$\overline{\text{FAULT1}}$

Block Diagram

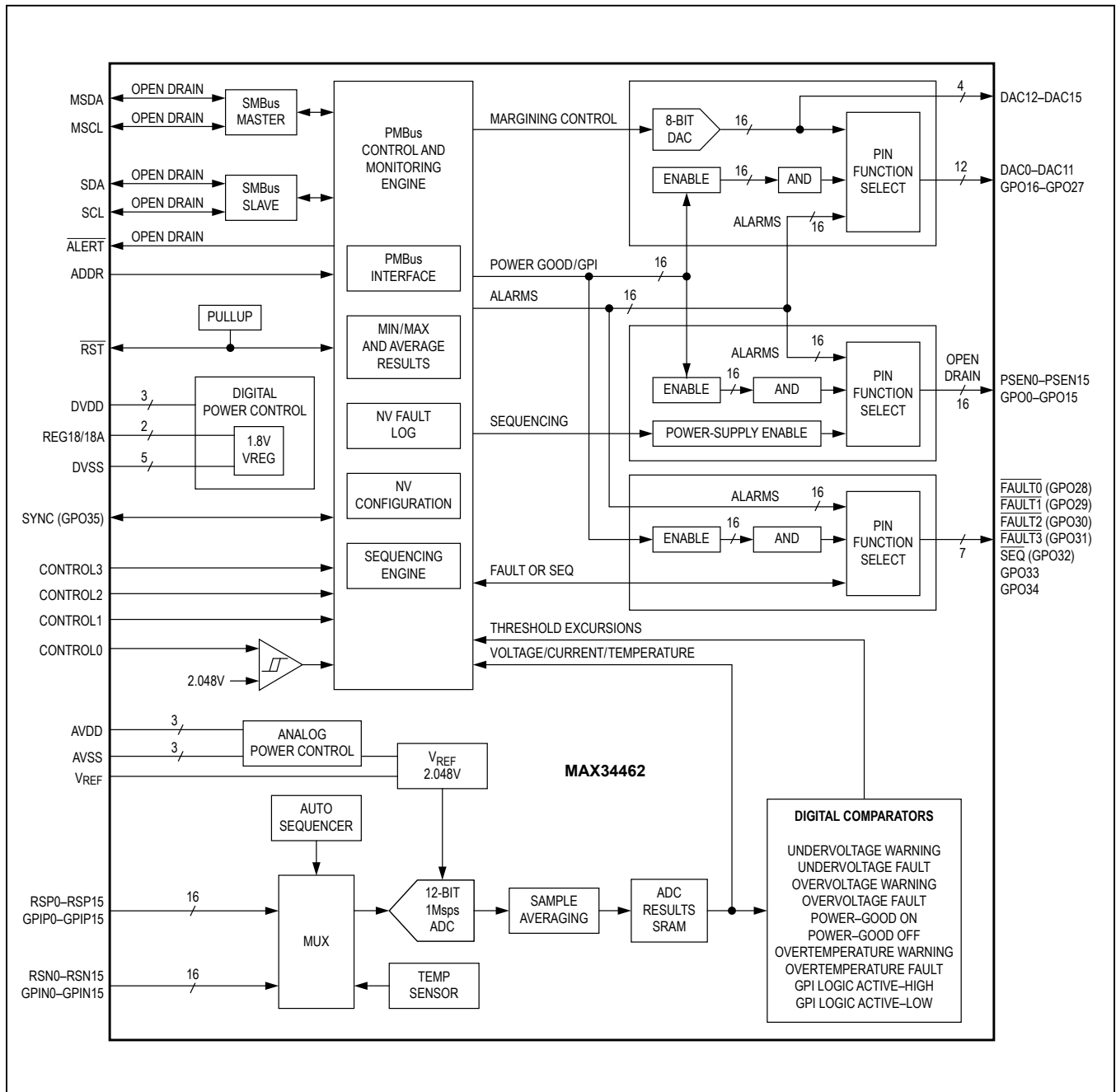

## Detailed Description

The MAX34462 is a highly-integrated system monitor with functionality to monitor up to 16 different voltages or currents and also to sequence and close-loop margin up to 16 power supplies. It also supports local and remote thermal sensing.

The power-supply manager monitors the power-supply output voltage and current and constantly checks for user-programmable overvoltage, undervoltage, and overcurrent thresholds. It can also margin the power-supply output voltage up or down by a user-programmable level. The margining is performed in a closed-loop arrangement, whereby the device automatically adjusts a DAC output voltage and then measures the resultant output voltage. The power-

supply manager can also sequence the supplies in any order at both power-up and power-down.

Thermal monitoring can be accomplished using up to five temperature sensors including an on-chip temperature sensor and up to four external remote DS75LV digital temperature sensors. Communications with the DS75LV temperature sensors is conducted via a dedicated I<sup>2</sup>C/SMBus interface.

The MAX34462 provides  $\overline{\text{ALERT}}$  and multiple  $\overline{\text{FAULT}}$  output signals. Host communications are conducted through a PMBus-compatible communications port.

See [Table 1](#) and [Table 2](#) for more details on specific device operation. [Table 3](#) shows the PMBus command codes.

**Table 1. PMBus PAGE to Pin/Resource Mapping**

PIN NAME	RS/GPI (16 AVAILABLE)			PSEN/GPO (16 AVAILABLE)			DAC/GPO (16 AVAILABLE (12 GPO))		
	VOLTAGE OR CURRENT MONITOR	GENERAL-PURPOSE INPUT (GPI)	BALL	POWER-SUPPLY ENABLE (PSEN)	GENERAL-PURPOSE OUTPUT (GPO)	BALL	DAC MARGIN OUTPUT (DAC)	GENERAL-PURPOSE OUTPUT (GPO)	BALL
0	RS0	GPI0	A1/A2	PSEN0	GPO0	G9	DAC0	GPO16	A9
1	RS1	GPI1	B2/B1	PSEN1	GPO1	F8	DAC1	GPO17	B8
2	RS2	GPI2	C2/C1	PSEN2	GPO2	G10	DAC2	GPO18	A8
3	RS3	GPI3	D2/D1	PSEN3	GPO3	F7	DAC3	GPO19	C7
4	RS4	GPI4	E1/E2	PSEN4	GPO4	F9	DAC4	GPO20	A6
5	RS5	GPI5	F1/F2	PSEN5	GPO5	E8	DAC5	GPO21	B6
6	RS6	GPI6	G1/G2	PSEN6	GPO6	F10	DAC6	GPO22	C6
7	RS7	GPI7	H1/H2	PSEN7	GPO7	E7	DAC7	GPO23	A5
8	RS8	GPI8	J1/J2	PSEN8	GPO8	H5	DAC8	GPO24	D6
9	RS9	GPI9	K1/K2	PSEN9	GPO9	K7	DAC9	GPO25	E4
10	RS10	GPI10	K3/J3	PSEN10	GPO10	F6	DAC10	GPO26	D5
11	RS11	GPI11	H3/H4	PSEN11	GPO11	J6	DAC11	GPO27	D4
12	RS12	GPI12	A3/B3	PSEN12	GPO12	H6	DAC12	N/A	D3
13	RS13	GPI13	A4/B4	PSEN13	GPO13	G6	DAC13	N/A	C3
14	RS14	GPI14	K4/J4	PSEN14	GPO14	J7	DAC14	N/A	C4
15	RS15	GPI15	K5/J5	PSEN15	GPO15	H7	DAC15	N/A	B5

**Table 2. Device Channel Capabilities and Options**

MAX34462 CHANNEL	PMBus COMMAND PAGE	CHANNEL CAPABILITIES
0 to 15	0 to 15	<p><b>Voltage Monitor/Sequence/Margin/GPO Option</b> Pins RS/GPI, PSEN, and DAC (where n = 0 to 15) have a one-to-one association for each channel that monitors for voltage (RS) and can be used to sequence (PSEN) and margin (DAC) the power supply. The voltage monitored on this channel can also be configured to determine a power-good state. If not required for either sequencing or margining, the associated PSEN and DAC outputs (only for DAC channels 0 to 11) can be repurposed as GPO outputs that can either indicate a logic combination of power-good (PG) and GPI states or report alarms.</p> <p><b>Current Monitor/GPO Option</b> If the RS/GPI input is used to monitor current, then the channel is not used to sequence or margin. The associated PSEN and DAC outputs (only for DAC channels 0 to 11) can be repurposed as GPO outputs that can either indicate a logic combination of power-good (PG) and GPI states or report alarms.</p> <p><b>GPI/GPO Option</b> If the RS/GPI input is configured as a general-purpose input (GPI), then it can be used as a term in a logic combination to determine a power-good (PG) state and assert a GPO output or act as a condition to allow a power supply to be enabled. The associated PSEN and DAC outputs (only for DAC channels 0 to 11) can be repurposed as GPO outputs that can be indicate power-good (PG) states or report alarms.</p>

**Table 3. PMBus Command Codes**

CODE	COMMAND NAME	TYPE	PAGE (Note 1)				# BYTE	FLASH STORED/ LOCKED (Note 2)	DEFAULT VALUE (Note 2)
			0-15	16-20	21-28	255			
00h	PAGE	R/W Byte	R/W	R/W	R/W	R/W	1	N/N	00h
01h	OPERATION	R/W Byte	R/W			W	1	N/N	00h
02h	ON_OFF_CONFIG	R/W Byte	R/W	R/W	R/W	R/W	1	Y/Y	1Ah
03h	CLEAR_FAULTS	Send Byte	W	W	W	W	0	N/N	—
10h	WRITE_PROTECT	R/W Byte	R/W	R/W	R/W	R/W	1	N/Y	00h
11h	STORE_DEFAULT_ALL	Send Byte	W	W	W	W	0	N/Y	—
12h	RESTORE_DEFAULT_ALL	Send Byte	W	W	W	W	0	N/Y	—
19h	CAPABILITY	Read Byte	R	R	R	R	1	N/N	20h/30h
20h	VOUT_MODE	Read Byte	R	R	R	R	1	FIXED/N	40h
21h	VOUT_COMMAND	R/W Word	R/W				2	Y/Y	0000h
25h	VOUT_MARGIN_HIGH	R/W Word	R/W				2	Y/Y	0000h
26h	VOUT_MARGIN_LOW	R/W Word	R/W				2	Y/Y	0000h
2Ah	VOUT_SCALE_MONITOR	R/W Word	R/W				2	Y/Y	7FFFh
38h	IOUT_CAL_GAIN	R/W Word	R/W				2	Y/Y	0000h
40h	VOUT_OV_FAULT_LIMIT	R/W Word	R/W				2	Y/Y	7FFFh
42h	VOUT_OV_WARN_LIMIT	R/W Word	R/W				2	Y/Y	7FFFh
43h	VOUT_UV_WARN_LIMIT	R/W Word	R/W				2	Y/Y	0000h

Table 3. PMBus Command Codes (continued)

CODE	COMMAND NAME	TYPE	PAGE (Note 1)				# BYTE	FLASH STORED/ LOCKED (Note 2)	DEFAULT VALUE (Note 2)
			0-15	16- 20	21- 28	255			
44h	VOUT_UV_FAULT_LIMIT	R/W Word	R/W				2	Y/Y	0000h
46h	IOOUT_OC_WARN_LIMIT	R/W Word	R/W				2	Y/Y	7FFFh
4Ah	IOOUT_OC_FAULT_LIMIT	R/W Word	R/W				2	Y/Y	7FFFh
4Fh	OT_FAULT_LIMIT	R/W Word		R/W			2	Y/Y	7FFFh
51h	OT_WARN_LIMIT	R/W Word		R/W			2	Y/Y	7FFFh
5Eh	POWER_GOOD_ON	R/W Word	R/W				2	Y/Y	0000h
5Fh	POWER_GOOD_OFF	R/W Word	R/W				2	Y/Y	0000h
60h	TON_DELAY	R/W Word	R/W				2	Y/Y	0000h
62h	TON_MAX_FAULT_LIMIT	R/W Word	R/W				2	Y/Y	FFFFh
64h	TOFF_DELAY	R/W Word	R/W				2	Y/Y	0000h
79h	STATUS_WORD	Read Word	R	R	R	R	2	N/N	0000h
7Ah	STATUS_VOUT	Read Byte	R				1	N/N	00h
7Bh	STATUS_IOUT	Read Byte	R				1	N/N	00h
7Dh	STATUS_TEMPERATURE	Read Byte		R			1	N/N	00h
7Eh	STATUS_CML	Read Byte	R	R	R	R	1	N/N	00h
80h	STATUS_MFR_SPECIFIC	Read Byte	R			R	1	N/N	00h
8Bh	READ_VOUT	Read Word	R				2	N/N	0000h
8Ch	READ_IOUT	Read Word	R				2	N/N	0000h
8Dh	READ_TEMPERATURE_1	Read Word		R			2	N/N	0000h
98h	PMBUS_REVISION	Read Byte	R	R	R	R	1	FIXED/N	11h
99h	MFR_ID	Read Byte	R	R	R	R	1	FIXED/N	4Dh
9Ah	MFR_MODEL	Read Byte	R	R	R	R	1	FIXED/N	5Ah
9Bh	MFR_REVISION	Read Word	R	R	R	R	2	FIXED/N	(Note 3)
9Ch	MFR_LOCATION	Block R/W	R/W	R/W	R/W	R/W	8	Y/Y	(Note 4)
9Dh	MFR_DATE	Block R/W	R/W	R/W	R/W	R/W	8	Y/Y	(Note 4)
9Eh	MFR_SERIAL	Block R/W	R/W	R/W	R/W	R/W	8	Y/Y	(Note 4)
D1h	MFR_MODE	Block R/W	R/W	R/W	R/W	R/W	2	Y/Y	0020h
D2h	MFR_PSEN_CONFIG	Block R/W	R/W				4	Y/Y	(Note 5)
D4h	MFR_VOUT_PEAK	R/W Word	R/W				2	N/Y	0000h
D5h	MFR_IOUT_PEAK	R/W Word	R/W				2	N/Y	0000h
D6h	MFR_TEMPERATURE_PEAK	R/W Word		R/W			2	N/Y	8000h
D7h	MFR_VOUT_MIN	R/W Word	R/W				2	N/Y	7FFFh
D8h	MFR_NV_LOG_CONFIG	R/W Word	R/W	R/W	R/W	R/W	2	Y/Y	0000h
D9h	MFR_FAULT_RESPONSE	Block R/W	R/W				4	Y/Y	(Note 5)
DAh	MFR_FAULT_RETRY	R/W Word	R/W	R/W	R/W	R/W	2	Y/Y	0000h
DCh	MFR_NV_FAULT_LOG	Block Read	R	R	R	R	255	Y/Y	(Note 6)
DDh	MFR_TIME_COUNT	Block R/W	R/W	R/W	R/W	R/W	4	N/Y	(Note 5)
DFh	MFR_MARGIN_CONFIG	R/W Word	R/W				2	Y/Y	0000h
E2h	MFR_IOUT_AVG	R/W Word	R				2	N/Y	0000h
E4h	MFR_CHANNEL_CONFIG	R/W Word	R/W				2	Y/Y	0000h

**Table 3. PMBus Command Codes (continued)**

CODE	COMMAND NAME	TYPE	PAGE (Note 1)				# BYTE	FLASH STORED/ LOCKED (Note 2)	DEFAULT VALUE (Note 2)
			0-15	16- 20	21- 28	255			
E6h	MFR_TON_SEQ_MAX	R/W Word	R/W				2	Y/Y	0000h
E8h	MFR_SEQ_CONFIG	Block R/W	R/W				4	Y/Y	(Note 5)
E9h	MFR_DAC_CONFIG (Note 7)	Block R/W	R/W				4	Y/Y	(Note 5)
EEh	MFR_STORE_ALL	Write Byte	W	W	W	W	1	N/Y	—
EFh	MFR_RESTORE_ALL	Write Byte	W	W	W	W	1	N/Y	—
F0h	MFR_TEMP_SENSOR_CONFIG	R/W Word		R/W			2	Y/Y	0000h
F8h	MFR_GPO_CONFIG	Block R/W			R/W		4	Y/Y	(Note 5)
FCh	MFR_STORE_SINGLE	R/W Word	R/W	R/W	R/W	R/W	2	N/Y	0000h
FEh	MFR_CRC	R/W Word	R/W	R/W	R/W	R/W	2	N/Y	FFFFh

**Note 1:** Common commands are shaded. Access via any PAGE results in the same device response.

**Note 2:** In the **Flash Stored/Locked** column, the left “N” indicates that this parameter is not stored in flash memory when the STORE\_DEFAULT\_ALL or MFR\_STORE\_ALL command is executed and the value shown in the **Default Value** column is automatically loaded upon power-on reset or when the  $\overline{\text{RST}}$  pin is asserted. The left “Y” in the **Flash Stored/Locked** column indicates that the currently loaded value in this parameter is stored in flash memory when the STORE\_DEFAULT\_ALL or MFR\_STORE\_ALL command is executed and is automatically loaded upon power-on reset or when the  $\overline{\text{RST}}$  pin is asserted and the value shown in the **Default Value** column is the value when shipped from the factory. “FIXED” in the **Flash Stored** column means this value is fixed at the factory and cannot be changed. The value shown in the **Default Value** column is automatically loaded upon power-on reset or when the  $\overline{\text{RST}}$  pin is asserted. The right side Y/N indicates that when the device is locked, only the commands listed with “N” can be accessed. All other commands are ignored if written and return FFh if read. Only the PAGE, CLEAR\_FAULTS, OPERATION, and MFR\_SERIAL commands can be written to. The device unlocks if the upper 4 bytes of MFR\_SERIAL match the data written to the device.

**Note 3:** The factory-set value is dependent on the device hardware and firmware revision.

**Note 4:** The factory-set default value for this 8-byte block is 3130313031303130h.

**Note 5:** The factory-set default value for this 4-byte block is 00000000h.

**Note 6:** The factory-set default value for the complete block of the MFR\_NV\_FAULT\_LOG is FFh.

**Note 7:** MFR\_DAC\_CONFIG is only available for PAGES 0 to 11.

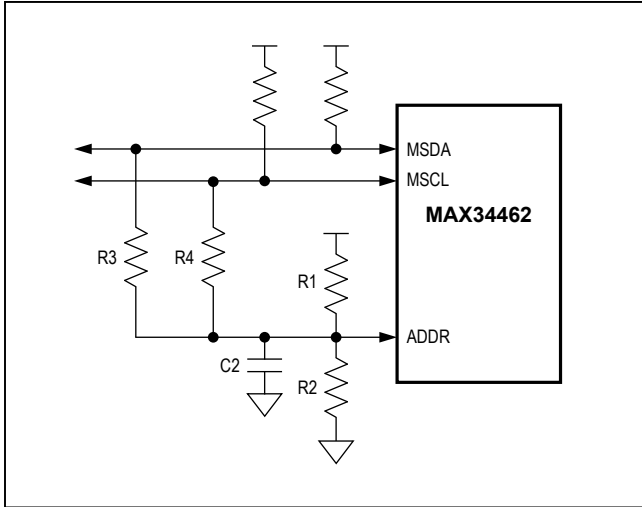

Figure 1. PMBus/SMBus Address Select

**PMBus/SMBus Address Select**

On device power-up, the device samples the ADDR pin to determine the PMBus/SMBus serial-port address. The combination of the components shown in [Figure 1](#) determines the serial-port address (also see [Table 4](#)).

**SMBus/PMBus Operation**

The device implements the PMBus command structure using the SMBus format. The structure of the data flow between the host and the slave is shown below for several different types of transactions. All transactions begin with a host sending a command code, which is immediately preceded with a 7-bit slave address ( $R/\bar{W} = 0$ ). Data is sent MSB first.

**Table 4. PMBus/SMBus Serial Port Address**

R1	R2	R3	R4	C2	7-BIT SLAVE ADDRESS
	220kΩ				1110 100 (E8h)
220kΩ					1110 101 (EAh)
220kΩ				100nF	0010 010 (24h)
22kΩ				100nF	0010 011 (26h)
		0kΩ			1001 100 (98h)
		220kΩ			1001 101 (9Ah)
			0kΩ		1011 000 (B0h)
			220kΩ		1011 001 (B2h)
	0kΩ				1001 110 (9Ch)

**Note:** The device also responds to a slave address of 34h (this is the factory programming address) and the devices should not share the same I<sup>2</sup>C bus with other devices that use this slave address.

**SMBus/PMBus Operation Examples**

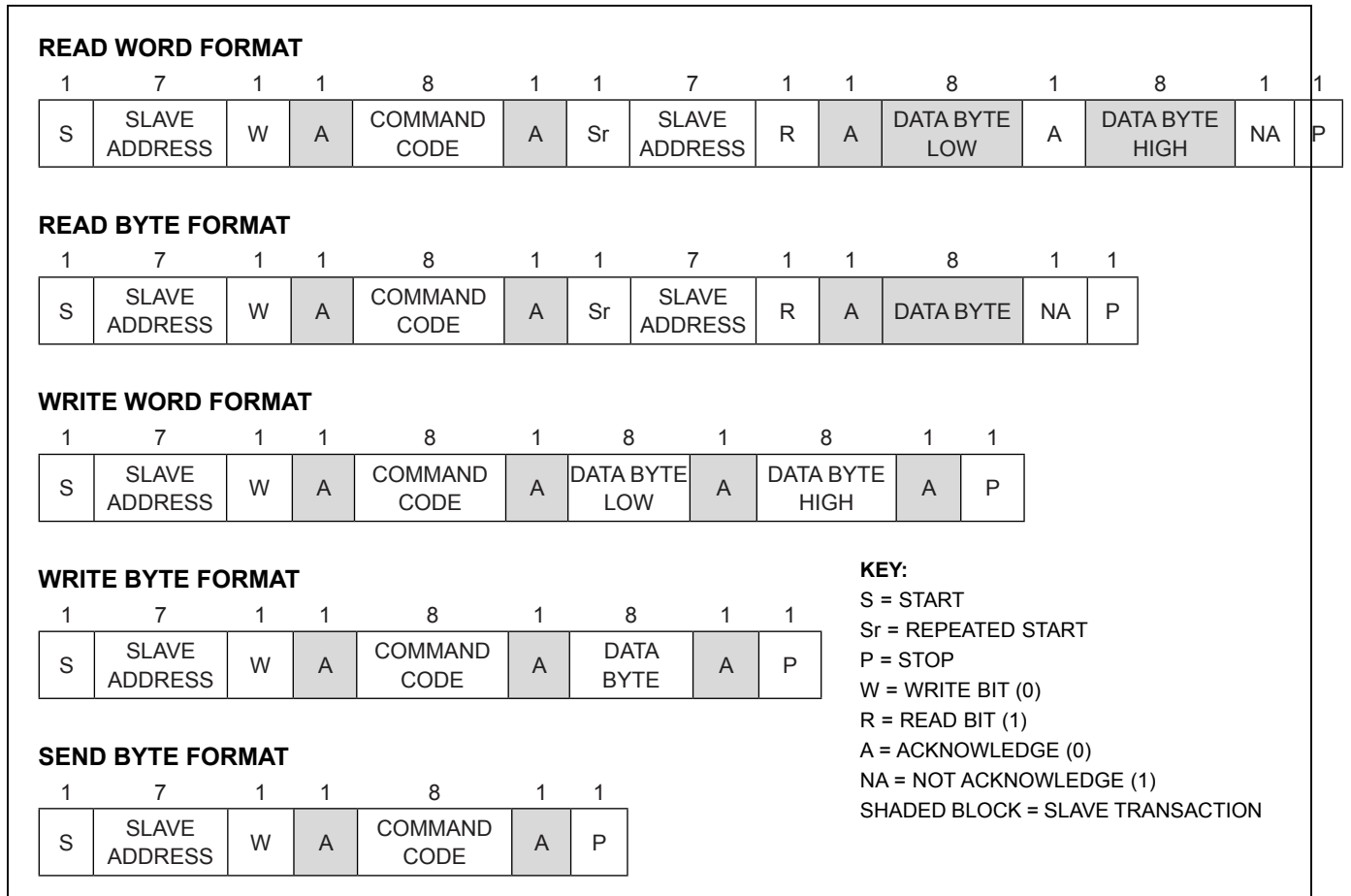

**Group Command**

The MAX34462 supports the group command. With the group command, a host can write different data to multiple devices on the same serial bus with one long continuous data stream. All the devices addressed during this transaction waits for the host to issue a STOP before beginning to respond to the command.

**Group Command Write Format**

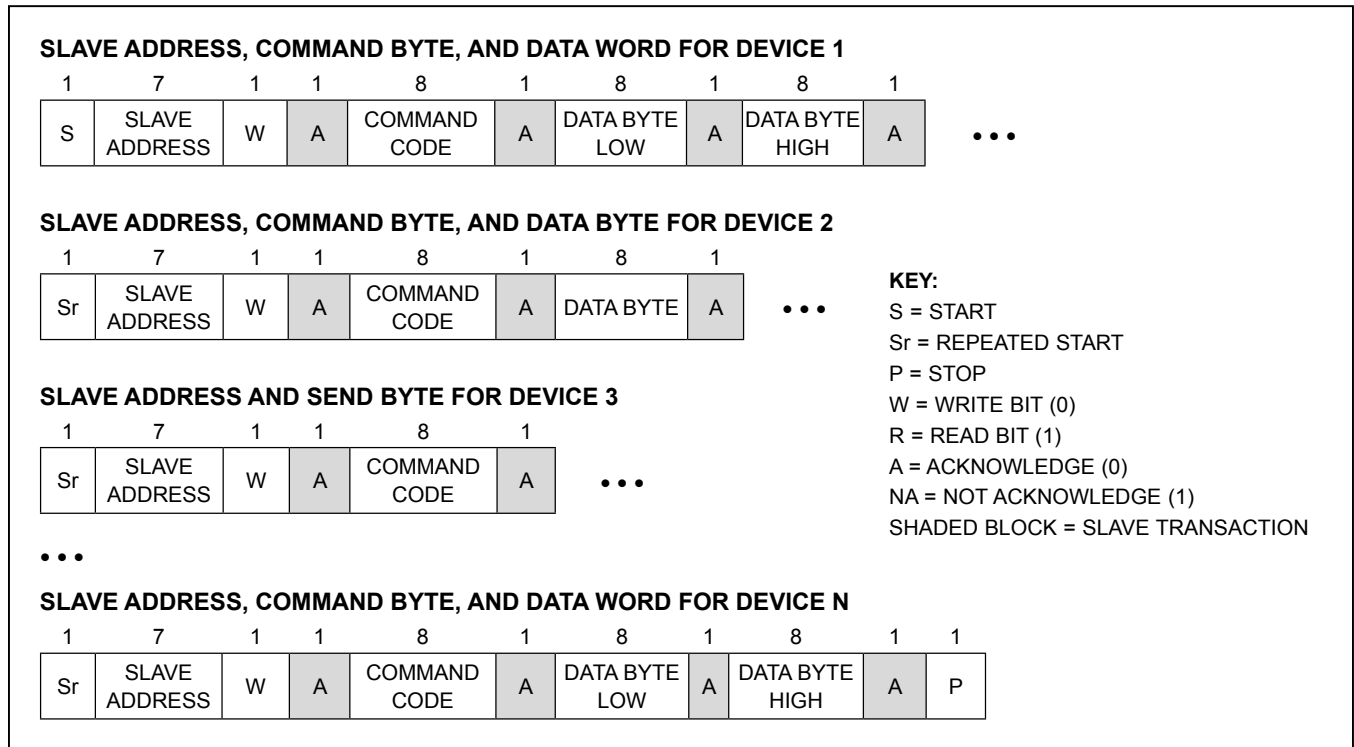

**Addressing**

The device responds to receiving its fixed slave address by asserting an acknowledge (ACK) on the bus. The device does not respond to a general call address; it only responds when it receives its fixed slave address or the alert response address. See the [ALERT and Alert Response Address \(ARA\)](#) section for more details.

**ALERT and Alert Response Address (ARA)**

If the  $\overline{\text{ALERT}}$  output is enabled (ALERT bit = 1 in MFR\_MODE), when a fault occurs, the device asserts the  $\overline{\text{ALERT}}$  signal and then waits for the host to send the alert response address (ARA), as shown below.

**Alert Response Address (ARA) Byte Format**

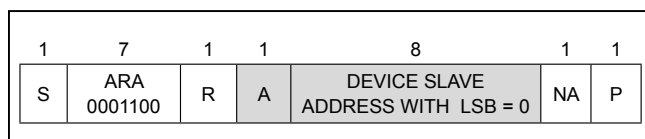

When the ARA is received and the device is asserting  $\overline{\text{ALERT}}$ , the device ACKs it and then attempts to place its fixed slave address on the bus by arbitrating the bus, since another device may also try to respond to the ARA. The rules of arbitration state that the lowest address device wins. If the device wins the arbitration, it deasserts  $\overline{\text{ALERT}}$ . If the device loses arbitration, it keeps  $\overline{\text{ALERT}}$  asserted and waits for the host to once again send the ARA.

**Host Sends or Reads Too Few Bits**

If for any reason, the host does not complete writing a full byte or reading a full byte from the device before a START or STOP is received, the device does the following:

- 1) Ignores the command.
- 2) Sets the CML bit in STATUS\_WORD.
- 3) Sets the DATA\_FAULT bit in STATUS\_CML.
- 4) Notifies the host through  $\overline{\text{ALERT}}$  assertion (if enabled).

**Host Sends or Reads Too Few Bytes**

For each supported command, the device expects a fixed number of bytes to be written or read from the device. If, for any reason, less than the expected number of bytes is written to or read from the device, the device completely ignores the command and takes no action.

**Host Sends Too Many Bytes or Bits**

For each supported command, the device expects a fixed number of bytes to be written to the device. If, for any reason, more than the expected number of bytes or bits is written to the device, the device does the following:

- 1) Ignores the command.
- 2) Sets the CML bit in STATUS\_WORD.
- 3) Sets the DATA\_FAULT bit in STATUS\_CML.
- 4) Notifies the host through  $\overline{\text{ALERT}}$  assertion (if enabled).

**Host Reads Too Many Bytes or Bits**

For each supported command, the device expects a fixed number of bytes to be read from the device. If, for any reason, more than the expected number of bytes or bits is read from the device, the device does the following:

- 1) Sends all ones (FFh) as long as the host keeps acknowledging.
- 2) Sets the CML bit in STATUS\_WORD.
- 3) Sets the DATA\_FAULT bit in STATUS\_CML.
- 4) Notifies the host through  $\overline{\text{ALERT}}$  assertion (if enabled).

**Host Sends Improperly Set Read Bit in the Slave Address Byte**

If the device receives the  $R/\overline{W}$  bit in the slave address set to a one immediately preceding the command code, the device acts as follows. Note this does not apply to ARA.

- 1) ACKs the address byte.
- 2) Sends all ones (FFh) as long as the host keeps acknowledging.
- 3) Sets the CML bit in STATUS\_WORD.
- 4) Sets the DATA\_FAULT bit in STATUS\_CML.
- 5) Notifies the host through  $\overline{\text{ALERT}}$  assertion (if enabled).

**Unsupported Command Code Received/Host Writes to a Read-Only Command**

If the host sends the device a command code that it does not support, or if the host sends a command code that is not supported by the current PAGE setting, the device does the following:

- 1) Ignores the command.
- 2) Sets the CML bit in STATUS\_WORD.

- 3) Sets the COMM\_FAULT bit in STATUS\_CML.
- 4) Notifies the host through  $\overline{\text{ALERT}}$  assertion (if enabled).

**Invalid Data Received**

The device checks the PAGE, OPERATION, and WRITE\_PROTECT command codes for valid data. If the host writes a data value that is invalid, the device does the following:

- 1) Ignores the command.
- 2) Sets the CML bit in STATUS\_WORD.
- 3) Sets the DATA\_FAULT bit in STATUS\_CML.
- 4) Notifies the host through  $\overline{\text{ALERT}}$  assertion (if enabled).

**Host Reads from a Write-Only Command**

When a read request is issued to a write-only command (CLEAR\_FAULTS, STORE\_DEFAULT\_ALL, RESTORE\_DEFAULT\_ALL, MFR\_STORE\_ALL, MFR\_RESTORE\_ALL, OPERATION with PAGE = 255), the device does the following:

- 1) ACKs the address byte.
- 2) Ignores the command.
- 3) Sends all ones (FFh) as long as the host keeps acknowledging.
- 4) Sets the CML bit in STATUS\_WORD.
- 5) Sets the DATA\_FAULT bit in STATUS\_CML.
- 6) Notifies the host through  $\overline{\text{ALERT}}$  assertion (if enabled).

**SMBus Timeout**

If, during an active SMBus communication sequence, the SCL signal is held low for greater than the timeout duration (nominally 27ms), the device terminates the sequence and resets the serial bus. It takes no other action. No status bits are set.

**PMBus Operation**

From a software perspective, the device appears as a PMBus device capable of executing a subset of PMBus commands. A PMBus 1.1-compliant device uses the SMBus version 1.1 for transport protocol and responds to the SMBus slave address. In this data sheet, the term SMBus is used to refer to the electrical characteristics of the PMBus communication using the SMBus physical layer. The term PMBus is used to refer to the PMBus command protocol. The device employs a number of standard SMBus protocols (e.g., Write Word, Read Word, Write Byte, Read Byte, Send Byte, etc.) to program output voltage and warning/faults thresholds, read monitored data, and provide access to all manufacturer-specific commands.

The device supports the group command. The group command is used to send commands to more than one PMBus device. It is not required that all the devices receive the same command. However, no more than one command can be sent to any one device in one group command packet. The group command must not be used with commands that require receiving devices to respond with data, such as the STATUS\_WORD command. When the device receives a command through this protocol, it immediately begins execution of the received command after detecting the STOP condition.

The device supports the PAGE command and uses it to select which individual channel to access. When a data word is transmitted, the lower order byte is sent first and the higher order byte is sent last. Within any byte, the most significant bit (MSB) is sent first and the least significant bit (LSB) is sent last.

### PMBus Protocol Support

The device supports a subset of the commands defined in the PMBus Power System Management Protocol Specification Part II - Command Language Revision 1.1. For detailed specifications and the complete list of PMBus commands, refer to Part II of the PMBus specification available at [www.PMBus.org](http://www.PMBus.org). The supported PMBus commands and the corresponding MAX34462 behavior are described in this document. All data values are represented in DIRECT format, unless otherwise stated. Whenever the PMBus specification refers to the PMBus device, it is referring to the MAX34462 operating in conjunction with a power supply. While the command may call for turning on or off the PMBus device, the MAX34462 always remains on to continue communicating with the PMBus master and the MAX34462 transfers the command to the power supply accordingly.

**Table 5. PMBus Command Code Coefficients**

PARAMETER	COMMANDS	UNITS	RESOLUTION	MAXIMUM	m	b	R
Voltage	VOUT_COMMAND VOUT_MARGIN_HIGH VOUT_MARGIN_LOW VOUT_OV_FAULT_LIMIT VOUT_OV_WARN_LIMIT VOUT_UV_WARN_LIMIT VOUT_UV_FAULT_LIMIT POWER_GOOD_ON POWER_GOOD_OFF READ_VOUT MFR_VOUT_PEAK MFR_VOUT_MIN	mV	1	32,767	1	0	0
Voltage Scaling	VOUT_SCALE_MONITOR	—	1/32,767	1	32,767	0	0
Current	IOUT_OC_FAULT_LIMIT IOUT_OC_WARN_LIMIT READ_IOUT MFR_IOUT_PEAK MFR_IOUT_AVG	A	0.01	327.67	1	0	2
Current Scaling	IOUT_CAL_GAIN	mΩ	0.1	3276.7	1	0	1
Temperature	OT_FAULT_LIMIT OT_WARN_LIMIT READ_TEMPERATURE_1 MFR_TEMPERATURE_PEAK	°C	0.01	327.67	1	0	2
Timing	TON_DELAY TON_MAX_FAULT_LIMIT TOFF_DELAY MFR_FAULT_RETRY MFR_TON_SEQ_MAX	ms	0.2	6553.4	5	0	0

## Data Format

Voltage data for commanding or reading the output voltage or related parameters (such as the overvoltage threshold) are presented in DIRECT format. DIRECT format data is a 2-byte, two's complement binary value. DIRECT format data may be used with any command that sends or reads a parametric value. The DIRECT format uses an equation and defined coefficients to calculate the desired values. The coefficients used by the device can be found in [Table 5](#).

## Interpreting Received DIRECT Format Values

The host system uses the following equation to convert the value received from the PMBus device, in this case the MAX34462, into a reading of volts, degrees Celsius, or other units as appropriate:

$$X = (1/m) \times (Y \times 10^{-R} - b)$$

where:

X = calculated, real world value in the appropriate units (V, °C, etc.)

m = slope coefficient

Y = 2-byte, two's complement integer received from the PMBus device

b = offset

R = exponent

## Sending a DIRECT Format Value

To send a value, the host must use the equation below to solve for Y:

$$Y = (mX + b) \times 10^R$$

where:

Y = 2-byte, two's complement integer to be sent to the unit

m = slope coefficient

X = real world value, in units such as volts, to be converted for transmission

b = offset

R = exponent

**Table 6. Coefficients for DIRECT Format Value**

COMMAND CODE	COMMAND NAME	m	b	R
25h	VOUT_MARGIN_HIGH	1	0	0
8Bh	READ_VOUT	1	0	0

The following example demonstrates how the host can send and retrieve values from the device. [Table 6](#) lists the coefficients used in the following parameters.

If a host wants to set the device to change the power-supply output voltage to 3.465V (or 3465mV), the corresponding VOUT\_MARGIN\_HIGH value is:

$$Y = (1 \times 3465 + 0) \times 10^0 = 3465 \text{ (decimal)} = 0D89\text{h (hex)}$$

Conversely, if the host received a value of 0D89h on a READ\_VOUT command, this is equivalent to:

$$X = (1/1) \times (0D89\text{h} \times 10^{-0}) - 0 = 3465\text{mV} = 3.465\text{V}$$

Power supplies and power converters generally have no way of knowing how their outputs are connected to ground. Within the power supply, all output voltages are most commonly treated as positive. Accordingly, all output voltages and output voltage-related parameters of PMBus devices are commanded and reported as positive values. It is up to the system to know that a particular output is negative if that is of interest to the system. All output voltage-related commands use 2 data bytes.

## Fault Management and Reporting

For reporting faults/warnings to the host on a real-time basis, the device asserts the open-drain  $\overline{\text{ALERT}}$  (if enabled in MFR\_MODE) pin and sets the appropriate bit in the various status registers. On recognition of the  $\overline{\text{ALERT}}$  assertion, the host or system manager is expected to poll the I<sup>2</sup>C bus to determine the device asserting  $\overline{\text{ALERT}}$ . The host sends the SMBus Alert Response Address (0001 100). The device ACKs the SMBus ARA, transmit its slave address, and deasserts  $\overline{\text{ALERT}}$ . The system controller then communicates with PMBus commands to retrieve the fault/warning status information from the device.

See the individual command sections for more details. Faults and warnings that are latched in the status registers are cleared when any one of the following conditions occurs:

- A CLEAR\_FAULTS command is received.
  - $\overline{\text{RST}}$  pin is toggled or a soft reset is issued.
  - Bias power to the device is removed and then reapplied.
- One or more latched off power supplies are only restarted when one of the following occurs:
- OPERATION commands are received that turn off and on the power supplies or the CONTROL0/1/2/3 pin is toggled to turn off and then turn on the power supplies.
  - $\overline{\text{RST}}$  pin is toggled or a soft reset is issued.
  - Bias power to the device is removed and then reapplied.

The device responds to fault conditions according to the configuration of the MFR\_FAULT\_RESPONSE command. This command determines how the device should respond to each particular fault and whether it should assert one of more of the FAULT pins when a fault occurs.

The MFR\_FAULT\_RESPONSE command also determines whether a channel should power-up if a fault is present. With the RESPONSE bits in MFR\_FAULT\_RESPONSE, each channel can be independently configured to either respond (or not respond) to each possible fault. Before any power-supply channel is enabled or the FAULT outputs are deasserted, the device checks for overvoltage, overcurrent, and temperature faults (but not for undervoltage) if the channel is configured for a fault response to either latching (RESPONSE[1:0] = 01) or retry (RESPONSE[1:0] = 10) in the MFR\_FAULT\_RESPONSE command. Only after the faults clear is the channel allowed to turn on. See [Table 7](#) for fault-monitoring states.

### Password Protection

The device can be password protected by using the LOCK bit in the MFR\_MODE command. Once the device is locked, only certain PMBus commands can be accessed

with the serial port. See [Table 3](#) for a complete list of commands. Commands that have password protection return all ones (FFh) with the proper number of data bytes when read. When the device is locked, only the PAGE, OPERATION, CLEAR\_FAULTS, and MFR\_SERIAL commands can be written; all other written commands are ignored. When MFR\_SERIAL is written and the upper 4 bytes match the internally flash-stored value, the device unlocks and remains unlocked until the LOCK bit in MFR\_MODE is activated once again. The LOCK status bit in STATUS\_MFR\_SPECIFIC is always available to indicate whether the device is locked or unlocked.

### Power-Supply Sequencing

Sequencing control for each of the 16 power-supply channels on the device is configured using the MFR\_SEQ\_CONFIG and ON\_OFF\_CONFIG commands. See the descriptions of these commands for details on the exact device configuration required. Power supplies can be powered up and down in any order even across multiple devices. See the command descriptions and [Figure 2](#) for specifics on sequencing control.

**Table 7. Fault-Monitoring States**

FAULT	REQUIRED DEVICE CONFIGURATION FOR ACTIVE MONITORING	WHEN MONITORED
Overvoltage	<ul style="list-style-type: none"> <li>Voltage monitoring enabled (SELECT[5:0] = 10h or 20h in MFR_CHANNEL_CONFIG)</li> </ul>	Continuous monitoring.
Undervoltage	<ul style="list-style-type: none"> <li>Voltage monitoring enabled (SELECT[5:0] = 10h or 20h in MFR_CHANNEL_CONFIG)</li> </ul>	Stop monitoring while the power supply is off; start monitoring when voltage exceeds the POWER_GOOD_ON level.
Overcurrent	<ul style="list-style-type: none"> <li>Current monitoring enabled (SELECT[5:0] = 22h in MFR_CHANNEL_CONFIG)</li> </ul>	Continuous monitoring.
Power-Up Time	<ul style="list-style-type: none"> <li>Sequencing enabled (SELECT[5:0] = 10h in MFR_CHANNEL_CONFIG)</li> </ul>	Monitored only during power-on sequence.
Overtemperature	<ul style="list-style-type: none"> <li>Temperature sensor enabled (ENABLE = 1 in MFR_TEMP_SENSOR_CONFIG)</li> </ul>	Continuous monitoring.

**Note:** Device response to faults is determined by the configuration of MFR\_FAULT\_RESPONSE.

**Quad-Loop Sequencing**

The device contains four independent sequencing groups: SEQUENCE0, SEQUENCE1, SEQUENCE2, and SEQUENCE3. All groups do not need to be used, but every channel is assigned to one of the groups with the SEQ\_SELECT bits in the MFR\_SEQ\_CONFIG command. The four sequencing groups operate independently. SEQUENCE0 is always associated with CONTROL0 and SEQUENCE1 is always associated with CONTROL1,

and so on. The four sequencing groups can also be independently controlled with the OPERATION command. With the ON\_OFF\_CONFIG command, the device is configured to respond to CONTROL0/1/2/3 pins or the OPERATION command (or both). When the OPERATION command is sent to the device when the PAGE is set to 255, all four sequence groups are controlled as shown in Table 8.

**Table 8. OPERATION Command Sequence Control Options**

GROUP	OPERATION COMMAND (PAGE = 255)		
	ON	SOFT-OFF	IMMEDIATE OFF
SEQUENCE0	80h or 81h	40h or 41h	00h or 01h
SEQUENCE1	80h or 82h	40h or 42h	00h or 02h
SEQUENCE2	80h or 83h	40h or 43h	00h or 03h
SEQUENCE3	80h or 84h	40h or 44h	00h or 04h

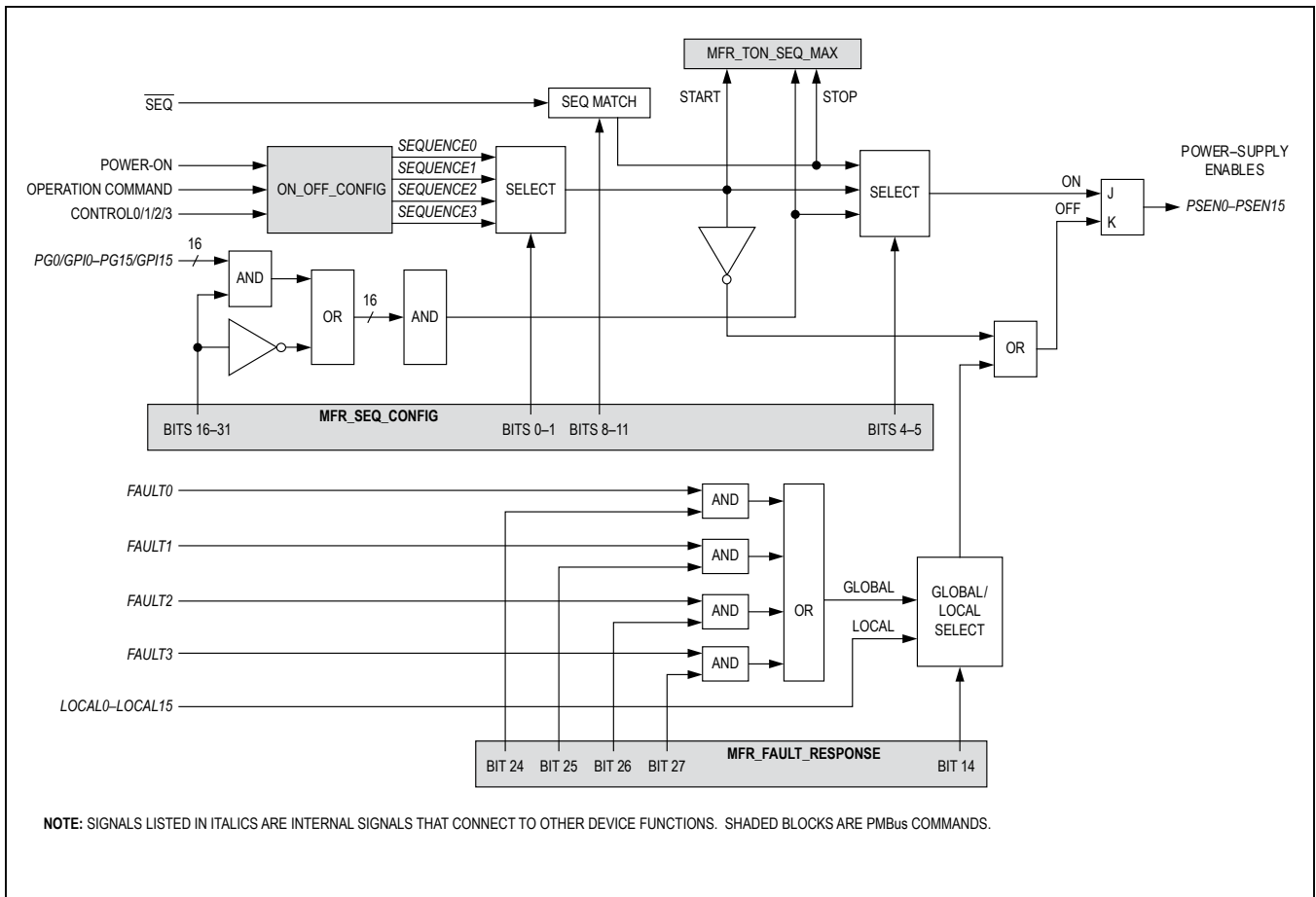

Figure 2. Sequence Control Logic

### Power-On Sequencing

The activation of all power-supply channels (even across multiple devices) is initiated from a common start signal that can be either the CONTROL pins or the OPERATION command. Each power-supply channel on the device can be sequenced on by one of the following methods.

- Power applied to the device.
- The CONTROL0 pin goes active.
- The CONTROL1 pin goes active.
- The CONTROL2 pin goes active.
- The CONTROL3 pin goes active.
- The OPERATION command is received.
- The logic combination of power-goods and GPI is valid.
- The  $\overline{\text{SEQ}}$  pin signal is matched.

Each enabled PSEN output goes active (can be active high or low as defined in MFR\_PSEN\_CONFIG) after the associated delay time programmed in TON\_DELAY. The power supplies can be sequenced on in any order. Each channel can be sequenced on with either time-based or event-based conditions. The output voltage of each power supply is monitored to make sure that the supply crosses the power-good on level (as configured in the POWER\_GOOD\_ON command) within a programmable time limit as configured in the TON\_MAX\_FAULT\_LIMIT command. This power-up time limit can be disabled by configuring TON\_MAX\_FAULT\_LIMIT to 0000h. For channels using event-based sequencing, the MFR\_TON\_SEQ\_MAX command determines the maximum time limit for the sequence on event to occur. Like the TON\_MAX\_FAULT\_LIMIT, this limit can be disabled by configuring MFR\_TON\_SEQ\_MAX to 0000h. There is one to one correspondence between RS inputs and PSEN outputs. For example, RS6 monitors the power supply controlled by PSEN6. All power-on sequencing is gated by detected faults. Before any power-supply channel is enabled (or  $\overline{\text{FAULT}}$  output is deasserted), the device checks for overvoltage, overcurrent, and temperature faults that are enabled (but not for undervoltage since the supply is off).

### Power-Off Sequencing

The order in which the supplies are disabled is determined with the TOFF\_DELAY configuration. Alternatively, all the power supplies can be switched off immediately as configured in the ON\_OFF\_CONFIG command or with the OPERATION command.

As configured with the ON\_OFF\_CONFIG command, either the CONTROL0/1/2/3 pins or the OPERATION command are the master off switch. When either the CONTROL pin goes inactive or the OPERATION off command is received (or one the enabled  $\overline{\text{FAULT}}$  pins is asserted), the power supplies are sequenced off. Neither the power-good (PG) and GPI logic combinations nor the  $\overline{\text{SEQ}}$  pin can be used to turn off power supplies.

### Sequencing Example

For example, [Figure 3](#) details a simple sequencing scheme consisting of four power supplies using a mixture of time-based and event-based sequencing. Channels 0 and 2 use time-based sequencing and channels 1 and 5 use event-based sequencing. When either the CONTROL0/1/2/3 pin goes active or the OPERATION command is received (as defined by the ON\_OFF\_CONFIG command), PSEN0 is asserted after the delay time configured in TON\_DELAY. RS0 is monitored to make sure that the PSEN0 supply crosses the power-good on level (as configured in POWER\_GOOD\_ON) within a programmable time limit (as configured in TON\_MAX\_FAULT\_LIMIT). PSEN2 operates in a similar fashion as PSEN0 but with a different TON\_DELAY and a different TON\_MAX\_FAULT\_LIMIT. Since the power-up of channels 0 and 2 are based solely on their TON\_DELAY values, these channels are time-based.

When RS2 crosses its power-good on level, PSEN5 is asserted after its configured TON\_DELAY and similarly PSEN1 will assert when RS5 crosses its power-good on level. Since the power-up of channels 5 and 1 are based on the power-good states of other channels, these channels are event-based. The MFR\_TON\_SEQ\_MAX command can be used to insure these events occur and the power-up sequence does not hang waiting for an event

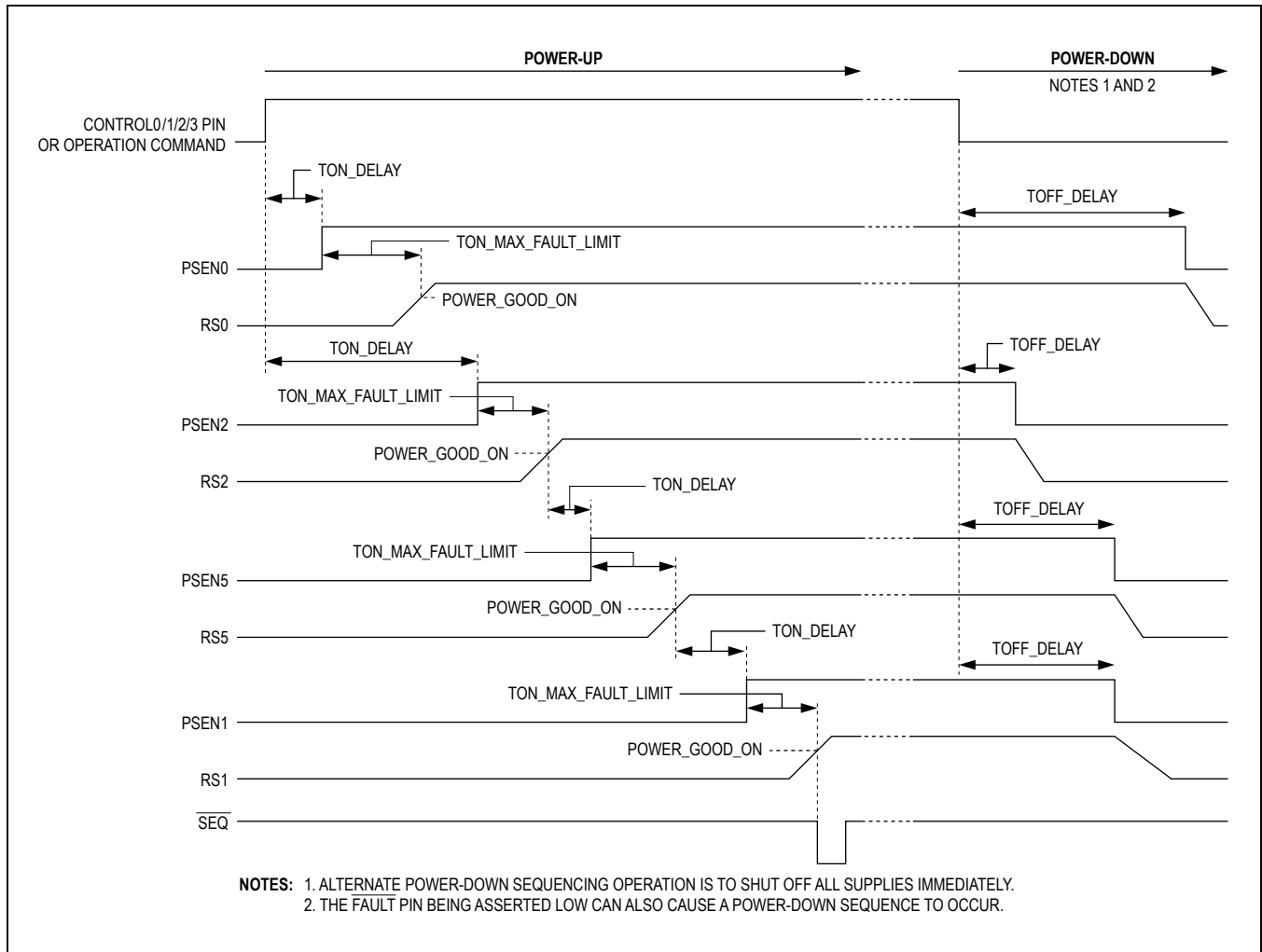

Figure 3. Sequencing Example

to transpire. When RS1 crosses its power-good on level, it has been configured to generate a  $\overline{SEQ}$  pin signal to communicate to another device to turn on one or more of its power supplies.

**Multiple Device Connections**

Multiple MAX34462 devices can be connected together to increase the system channel count. Figure 4 details the recommended connection scheme.

All the paralleled devices share the same CONTROL,  $\overline{FAULT}$ ,  $\overline{SEQ}$ , and SMBus signals. All the devices use a common signal (either the CONTROL0 to CONTROL3

pins or the OPERATION command) to enable and disable all the power supplies. Any of the monitored power supplies can be configured with the MFR\_FAULT\_RESPONSE command to activate one or more of the  $\overline{FAULT}$  signals and shut down all the other supplies enabled to respond to one or more of the  $\overline{FAULT}$  signals. The use of multiple faults signals allows more flexibility in controlling which power supplies need to shut down during a fault.

**USER NOTE:** All devices must be configured with the same ON\_OFF\_CONFIG configuration. All devices must be powered up and reset at the same time.

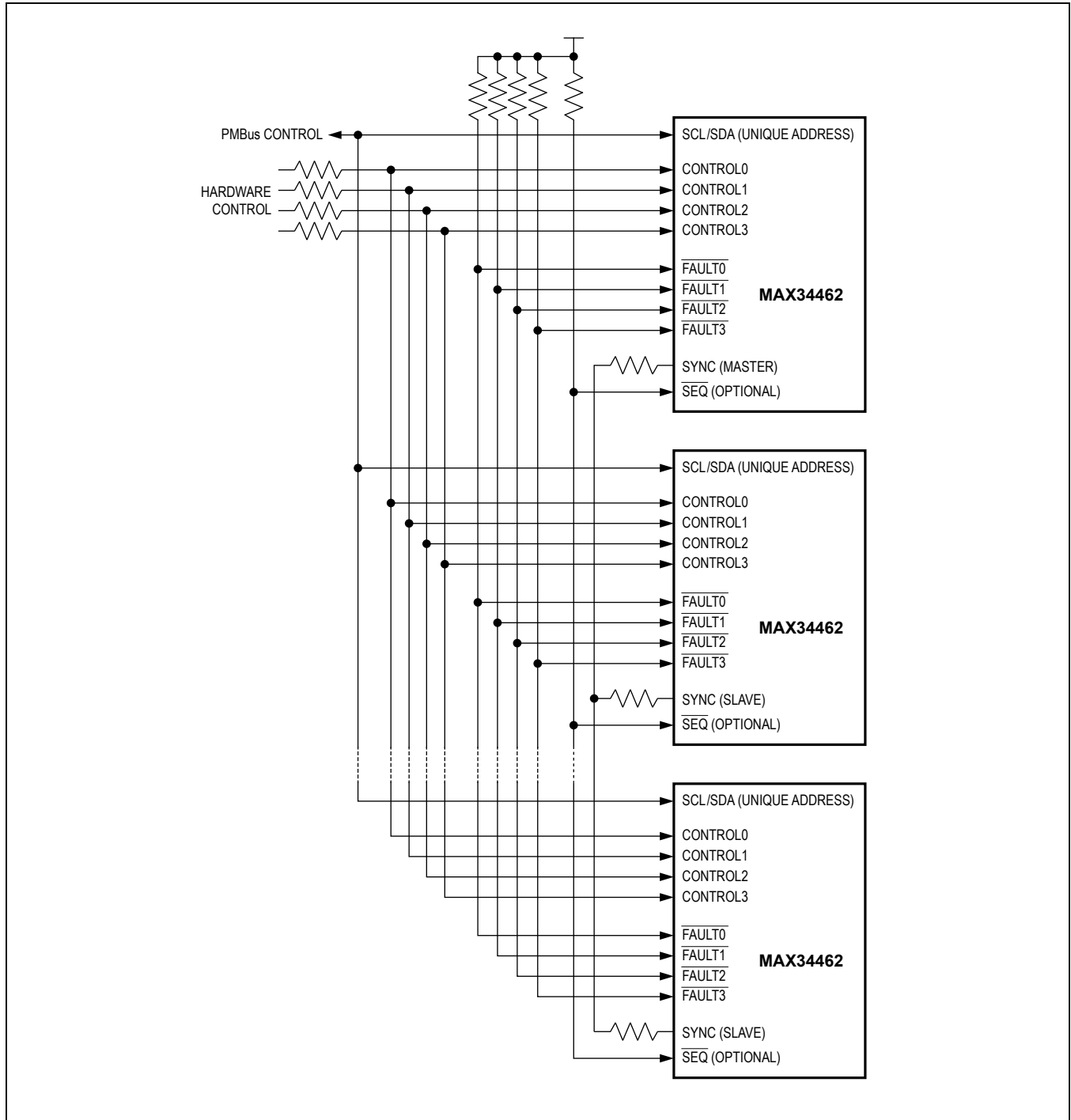

Figure 4. Multiple MAX34462 Hardware Connections

### SEQ Pin Operation

The  $\overline{\text{SEQ}}$  pin is an optional signal. When this function is enabled, it allows multiple devices to coordinate event-based sequencing. With the MFR\_CHANNEL\_CONFIG command, any channel can be configured to generate one of 15 signatures. When the channel crosses its power-good on level, it generates the needed  $\overline{\text{SEQ}}$  signature if so enabled. With the MFR\_SEQ\_CONFIG command, any of the sequencing channels (PAGES 0 to 15) can be configured to wait for a match on the  $\overline{\text{SEQ}}$  pin before asserting the PSEN output. To ensure that a valid  $\overline{\text{SEQ}}$  signal is received when it should be, the maximum allowable time is configured into the MFR\_TON\_SEQ\_MAX command.

**USER NOTE: Only one channel should be configured with any one particular  $\overline{\text{SEQ}}$  signature. If two channels had the same signature, they might reach their power-good on levels at different times and corrupt the  $\overline{\text{SEQ}}$  signal. Allow more than 15ms between consecutive  $\overline{\text{SEQ}}$  signatures.**

### SYNC Pin Operation

In a multiple device application, one MAX34462 is configured as the SYNC master and it provides a 20kHz clock to the rest of the devices that accept the 20kHz clock and slaves their timing to this clock to allow all the devices to use the same clock source for power-supply sequencing. A small series resistor (100 $\Omega$ ) is recommended to prevent output shorts should two masters become active at the same time. This should not occur with proper device configuration.

The SYNC master or slave selection is configured with the SYNC bit in MFR\_MODE. If the SYNC pin is configured as a slave, then once a second, the device checks whether the SYNC pin is toggling. If it is not toggling, then the device switches to an internal time base and sets the SYNC bit in STATUS\_MFR\_SPECIFIC (PAGE = 255). Once a missing signal is detected, the device adds a weak pullup to the SYNC input and continues to check once a second for the presence of the SYNC signal. If a SYNC signal is detected, the device switches to SYNC signal and allows the SYNC status bit to be cleared.

### System Watchdog Timer

The device uses an internal watchdog timer. This timer is internally reset every 5ms. In the event that the device is locked up and this watchdog reset does not occur after 210ms, the device automatically resets. After the reset occurs, the device reloads all configuration values that were stored to flash and begins normal operation. After the reset, the device also does the following:

- 1) Sets the MFR bit in STATUS\_WORD.
- 2) Sets the WATCHDOG\_INT bit in STATUS\_MFR\_SPECIFIC (for PAGE 255).
- 3) Notifies the host through  $\overline{\text{ALERT}}$  assertion (if enabled in MFR\_MODE).

### CRC Memory Check

Upon reset, the device runs an internal algorithm to check the integrity of the key internal nonvolatile memory. If the CRC check fails, the device does not power up and remains in a null state with all pins high impedance, but does assert the  $\overline{\text{FAULT0}}$  output.

### PMBus Commands

A summary of the PMBus commands supported by the device is described in the following sections.

#### PAGE (00h)

The device can monitor up to 16 voltages or currents and it can also sequence and margin up to 16 power supplies. The device can monitor up to five temperature sensors, one internal local temperature sensor plus four external remote temperature sensors (DS75LV). All the monitoring and control is accomplished using one PMBus (I<sup>2</sup>C) address. Send the PAGE command with data 0 to 28 (decimal) to select which power supply or temperature sensor or GPO function is affected by all the following PMBus commands. Not all commands are supported within each page. If an unsupported command is received, the CML status bit is set. Some commands are common, which means that any selected page has the same affect on and the same response from the device. See [Table 9](#) for PAGE commands.

**Table 9. PAGE (00h) Commands**

PAGE	ASSOCIATED CONTROL	NOTES
0	Power supply monitored by RS0 and controlled by PSEN0 and margined with DAC0	1
1	Power supply monitored by RS1 and controlled by PSEN1 and margined with DAC1	1
2	Power supply monitored by RS2 and controlled by PSEN2 and margined with DAC2	1
3	Power supply monitored by RS3 and controlled by PSEN3 and margined with DAC3	1
4	Power supply monitored by RS4 and controlled by PSEN4 and margined with DAC4	1
5	Power supply monitored by RS5 and controlled by PSEN5 and margined with DAC5	1
6	Power supply monitored by RS6 and controlled by PSEN6 and margined with DAC6	1
7	Power supply monitored by RS7 and controlled by PSEN7 and margined with DAC7	1
8	Power supply monitored by RS8 and controlled by PSEN8 and margined with DAC8	1
9	Power supply monitored by RS9 and controlled by PSEN9 and margined with DAC9	1
10	Power supply monitored by RS10 and controlled by PSEN10 and margined with DAC10	1
11	Power supply monitored by RS11 and controlled by PSEN11 and margined with DAC11	1
12	Power supply monitored by RS12 and controlled by PSEN12 and margined with DAC12	1
13	Power supply monitored by RS13 and controlled by PSEN13 and margined with DAC13	1
14	Power supply monitored by RS14 and controlled by PSEN14 and margined with DAC14	1
15	Power supply monitored by RS15 and controlled by PSEN15 and margined with DAC15	1
16	Internal temperature sensor	
17	External DS75LV temperature sensor with I <sup>2</sup> C address 90h	
18	External DS75LV temperature sensor with I <sup>2</sup> C address 92h	
19	External DS75LV temperature sensor with I <sup>2</sup> C address 94h	
20	External DS75LV temperature sensor with I <sup>2</sup> C address 96h	
21	GPO28 (alternate function is FAULT0)	
22	GPO29 (alternate function is FAULT1)	
23	GPO30 (alternate function is FAULT2)	
24	GPO31 (alternate function is FAULT3)	
25	GPO32 (alternate function is SEQ)	
26	GPO33	
27	GPO34	
28	GPO35 (alternate function is SYNC)	
29–254	Reserved	2
255	Applies to all PAGES	3

**Note 1:** PAGES 0 to 15 can also be used to configure GPI and GPO operation.

**Note 2:** PAGES 64 to 92 can be used to write to temporary RAM. See the [Device Configuration Data Management](#) section for details.

**Note 3:** Set the PAGE to 255 when it is desired that the following PMBus commands should apply to all PAGES at the same time. There are only a few commands (OPERATION, CLEAR\_FAULTS) where this function has a real application.

**OPERATION (01h)**

The OPERATION command is used to turn the power supply on and off in conjunction with the CONTROL0/1/2/3 input pins. The OPERATION command is also used to cause the power supply to set the output voltage to the upper or lower margin voltages. The power supply stays in the commanded operating mode until a subsequent OPERATION command or a change in the state of the CONTROL0/1/2/3 pins (if enabled) instructs the power supply to change to another state. The valid OPERATION command byte values are shown in [Table 10](#). The OPERATION command controls how the device responds when commanded to change the output. When the command byte is 00h, the device immediately turns the power supply off and ignores any programmed turn-off delay. When the command byte is set to 40/41/42/43/44h, the device powers down according to the programmed turn-off delay. In [Table 10](#), [Table 11](#), and [Table 12](#), “act on any fault” means that if any warning or fault on the selected power supply is detected when the output is margined, the device treats this as a warning or fault and responds as programmed. Ignore all faults means that all warnings and

faults on the selected power supply are ignored. Any command value not shown in the tables is an invalid command. If the device receives a data byte that is not listed in the tables, then it treats this as invalid data, declares a data fault (set CML bit and assert ALERT), and responds as described in the [Fault Management and Reporting](#) section.

In most instances, for power-on and off control, the OPERATION command should be sent when the PAGE is set to 255. If the PAGE is set to 0 to 15, the OPERATION command only applies to the power supply on that page, and the power supply is turned on and off using the associated TON\_DELAY and TOFF\_DELAY settings without any regard to the other supplies.

For individual channel margining control, the OPERATION command can be used with the PAGE set to 0 to 15. When PAGE is set to 255, the OPERATION margining commands affect all channels.

The OPERATION command for the device contains a few special values that are not part of the PMBus standard to allow the device to offer independent control. See the shaded values in [Table 11](#).

**Table 10. OPERATION (01h) Command Byte with PAGE = 0 to 15 (When Bit 3 of ON\_OFF\_CONFIG = 1)**

COMMAND BYTE	POWER SUPPLY ON/OFF	MARGIN STATE
00h	Immediate off (no sequencing)	—
40h	Soft-off (with sequencing)	—
80h	On	Margin off
94h	On	Margin low (ignore all faults)
98h	On	Margin low (act on any fault)
A4h	On	Margin high (ignore all faults)
A8h	On	Margin high (act on any fault)

**Note:** All enabled channels must exceed POWER\_GOOD\_ON for margining to begin.

**Table 11. OPERATION (01h) Command Byte with PAGE = 255 (When Bit 3 of ON\_OFF\_CONFIG = 1)**

COMMAND BYTE	POWER SUPPLY ON/OFF	SEQUENCE AFFECTED	MARGIN STATE
00h	Immediate off (no sequencing)	SEQUENCE0 to SEQUENCE3	—
01h		SEQUENCE0 only	
02h		SEQUENCE1 only	
03h		SEQUENCE2 only	
04h		SEQUENCE3 only	
40h	Soft-off (with sequencing)	SEQUENCE0 to SEQUENCE3	—
41h		SEQUENCE0 only	
42h		SEQUENCE1 only	
43h		SEQUENCE2 only	
44h		SEQUENCE3 only	
80h	On	SEQUENCE0 to SEQUENCE3	Margin off
81h		SEQUENCE0 only	
82h		SEQUENCE1 only	
83h		SEQUENCE2 only	
84h		SEQUENCE3 only	
94h	On	SEQUENCE0 to SEQUENCE3	Margin low (ignore all faults)
98h	On		Margin low (act on any fault)
A4h	On		Margin high (ignore all faults)
A8h	On		Margin high (act on any fault)

**Note 1:** Special device OPERATION commands are shaded.

**Note 2:** When the OPERATION command is read, the device always responds with the standard command.

**Note 3:** All enabled channels must exceed POWER\_GOOD\_ON for margining to begin.

**Table 12. OPERATION (01h) Command Byte (When Bit 3 of ON\_OFF\_CONFIG = 0)**

COMMAND BYTE	POWER SUPPLY ON/OFF	MARGIN STATE
00h	Command has no effect	—
40h		—
80h		Margin off
94h		Margin low (ignore all faults)
98h		Margin low (act on any fault)
A4h		Margin high (ignore all faults)
A8h		Margin high (act on any fault)

**Note 1:** The device only takes action if the supply is enabled.

**Note 2:** All enabled channels must exceed POWER\_GOOD\_ON for margining to begin.

**Note 3:** If PAGE is set to 255, SEQUENCE0 to SEQUENCE3 are affected.

**ON\_OFF\_CONFIG (02h)**

The ON\_OFF\_CONFIG command configures the combination of CONTROL inputs and PMBus OPERATION commands needed to turn the power supply on and off. This indicates how the power supply is commanded when power is applied. The ON\_OFF\_CONFIG message content is described in Table 13. The host should not modify ON\_OFF\_CONFIG while the power supplies are active.

The configuration of the ON\_OFF\_CONFIG command applies to all the CONTROL pins. All the CONTROL pins must have the same polarity. If not all CONTROL pins are used, the unused CONTROL pins can be either connected low or connected to other active CONTROL pins. The MFR\_SEQ\_CONFIG command configures whether a CONTROL pin has any direct control or not and the state of unused CONTROL pins is ignored. See Figure 5.

**Table 13. ON\_OFF\_CONFIG (02h) Command Byte**

BIT NUMBER	PURPOSE	BIT VALUE	MEANING
7:6	Reserved	n/a	Always returns 000.
5	OPERATION command & CONTROL0/1/2/3 Pins AND/OR Select	0	OPERATION command is ANDed with CONTROL0/1/2/3 pins if both are enabled.
		1	OPERATION command is ORed with CONTROL0/1/2/3 pins if both are enabled.
4	Turn on supplies when bias is present or use the CONTROL0/1/2/3 pins / OPERATION command	0	Turn on the supplies (with sequencing if so configured) as soon as bias is supplied to the device regardless of the CONTROL0/1/2/3 pins.
		1	Use CONTROL0/1/2/3 pins (if enabled) and/or OPERATION command (if enabled). See note below.
3	OPERATION command enable	0	On/off portion of the OPERATION command disabled.
		1	OPERATION command enabled.
2	CONTROL0/1/2/3 pin enable	0	CONTROL0 to CONTROL3 pins disabled.
		1	CONTROL0 to CONTROL3 pins enabled.
1	CONTROL0/1/2/3 pin polarity	0	Active low (drive low to turn on the power supplies).
		1	Active high (drive high to turn on the power supplies).
0	CONTROL0/1/2/3 pin turn off action	0	Use the programmed turn off delay (soft off).
		1	Turn off the power supplies immediately.

**Note:** Unless bit 5 is set, if both bits 2 and 3 are set, both the CONTROL pins and the OPERATION command are required to turn the supplies on and either can turn the supplies off.

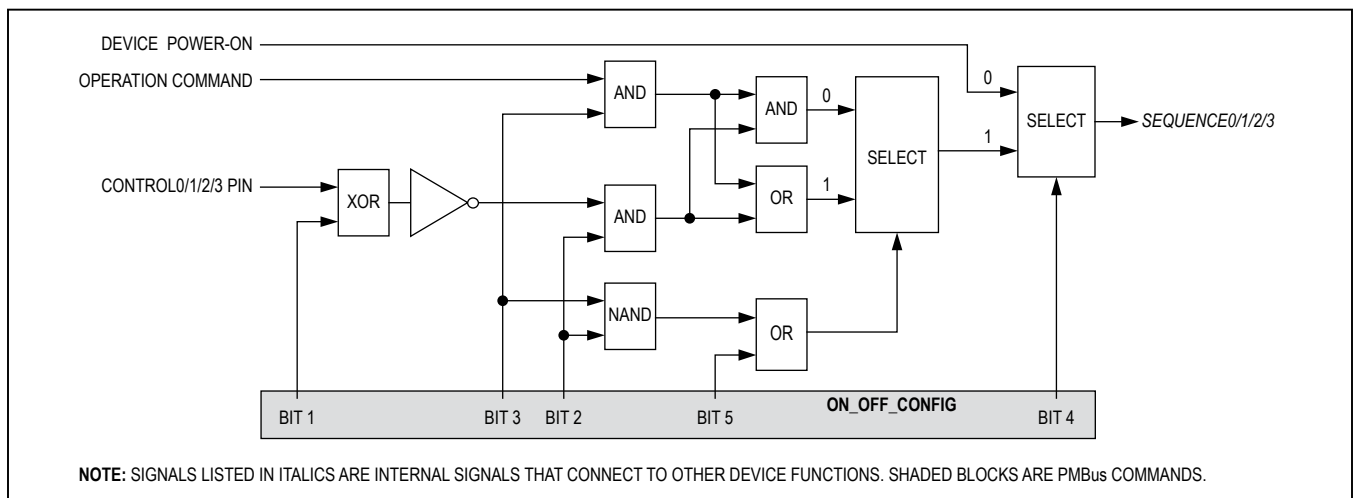

Figure 5. ON\_OFF\_CONFIG Logical Control

**CLEAR\_FAULTS (03h)**

The CLEAR\_FAULTS command is used to clear any latched fault or warning bits in the status registers that have been set and it also unconditionally deasserts the ALERT output. This command clears all bits simultaneously. The CLEAR\_FAULTS command does not cause a power supply that has latched off for a fault condition to restart. The state of PSEN outputs under fault conditions is not affected by this command and will change only if commanded through the OPERATION command or CONTROL0/1/2/3 pins. If a fault is still present after the CLEAR\_FAULTS command is executed, the fault status bit is immediately set again but ALERT is not reasserted. ALERT will only be asserted again when a new fault or warning is detected that occurs after the CLEAR\_FAULTS command is executed. This command is write-only. There is no data byte for this command.

**WRITE\_PROTECT (10h)**

The WRITE\_PROTECT command is used to provide protection against accidental changes to the device operating memory. All supported commands may have their parameters read, regardless of the WRITE\_PROTECT settings. The WRITE\_PROTECT message content is described in [Table 14](#).

**Device Configuration Data Management**

The device stores configuration data in both nonvolatile flash memory and volatile RAM. The PMBus engine manages the device configuration data. See [Figure 6](#).

The flash memory has three separate arrays for configuration parameters whereas the RAM only has two arrays. When a PMBus command is written to the device, it is always written to the RAM. If the PAGE has no offset from the PAGE number as listed in [Table 9](#), then the command is written to RAM OPERATING. If the PAGE has an offset of 64 decimal then the command is written to RAM TEMPORARY. Only “Flash Stored” commands should be written with the offset. Commands that are not stored in flash by the device (like OPERATION) are ignored. See [Table 3](#) for a list of commands that are flash stored.

When the device is shipped from the factory, the MAIN and BACKUP flash memory arrays are identical and they are configured as shown in [Table 3](#). The SINGLE array is empty.

There is a set of five PMBus commands that can be used to transfer data between the flash and RAM arrays. These commands are described in [Table 15](#).

**Table 14. WRITE\_PROTECT (10h) Command Byte**

COMMAND BYTE	MEANING
80h	Disables all writes except the WRITE_PROTECT command.
40h	Disables all writes except the WRITE_PROTECT, OPERATION, and PAGE commands.
20h	Disables all writes except the WRITE_PROTECT, OPERATION, PAGE, and ON_OFF_CONFIG commands.
00h	Enables writes for all commands (default).

**Note:** No fault or error is generated if the host attempts to write to a protected area.

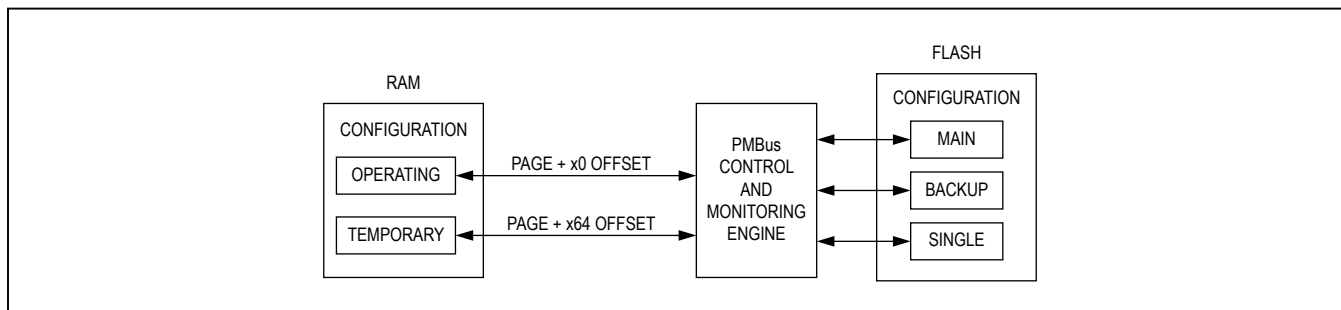

Figure 6. Device Configuration Data Management

**Table 15. Memory Transfer PMBus Commands**

PMBus COMMAND		RESULTING MEMORY TRANSFER
STORE_DEFAULT_ALL		Copy RAM OPERATING to flash MAIN.
RESTORE_DEFAULT_ALL		Copy flash MAIN to RAM OPERATING and RAM TEMPORARY.
MFR_STORE_ALL	CODE = 00h	Copy RAM OPERATING to flash MAIN.
	CODE = 01h	Copy RAM OPERATING to flash BACKUP.
	CODE = 02h	Copy RAM TEMPORARY to flash MAIN.
	CODE = 03h	Copy RAM TEMPORARY to flash BACKUP.
MFR_RESTORE_ALL	CODE = 00h	Copy flash MAIN array to RAM OPERATING.
	CODE = 01h	Copy flash BACKUP to RAM OPERATING.
	CODE = 02h	Copy flash MAIN to RAM TEMPORARY.
	CODE = 03h	Copy flash BACKUP to RAM TEMPORARY.
MFR_STORE_SINGLE		Copy RAM OPERATING (single parameter) to flash SINGLE.

**STORE\_DEFAULT\_ALL (11h)**

The STORE\_DEFAULT\_ALL command instructs the device to copy RAM OPERATING to the flash MAIN memory array. Not all information is stored. Only configuration data is stored, not any status, or operational data. If an error occurs during the transfer, ALERT asserts if enabled and the CML bit in and STATUS\_WORD is set to 1. No bits are set in STATUS\_CML. This command is write-only. There is no data byte for this command.

When the STORE\_DEFAULT\_ALL command is invoked, the device is unresponsive to PMBus commands and does not monitor power supplies while transferring the configuration. The time required to complete this task is listed in the [Electrical Characteristics](#). The MFR\_STORE\_SINGLE command allows a single command to be stored in much less time.

**USER NOTE:** V<sub>DD</sub> must be above 2.9V for the device to perform the STORE\_DEFAULT\_ALL command.

**RESTORE\_DEFAULT\_ALL (12h)**

The RESTORE\_DEFAULT\_ALL command instructs the device to copy the flash MAIN memory array to RAM OPERATING and RAM TEMPORARY. The RESTORE\_DEFAULT\_ALL command should only be executed when the device is not operating the power supplies. This command is write-only. There is no data byte for this command. When RESTORE\_DEFAULT\_ALL is issued, the data is checked for validity before being transferred. If the MAIN array is corrupt, the device sets bit 1 of STATUS\_CML and loads the BACKUP copy. If the BACKUP copy is corrupt, the device set bits 2 of STATUS\_CML and remains in a null state with all pins (except SCL and SDA) high impedance. The FAULT pin(s) is also asserted. To resolve the data corruption, the configuration data must be written to RAM OPERATING and STORE\_DEFAULT\_ALL must be issued followed by a device reset.

Upon a device power-on reset or any device reset, this command is automatically executed by the device without PMBus action required.

### MFR\_STORE\_ALL (EEh)

The MFR\_STORE\_ALL command instructs the device to copy RAM OPERATING or RAM TEMPORARY to either the flash MAIN memory array or the flash BACKUP memory array. Which transfer is to occur is determined by the CODE. This command is write-only. There is one data byte for this command which is the CODE. Only CODE values of 00h to 03h are valid; all other CODE values are ignored. Not all information is stored. Only configuration data is stored, not any status, or operational data. If an error occurs during the transfer, **ALERT** asserts if enabled and the CML bit in and STATUS\_WORD is set to 1. No bits are set in STATUS\_CML. Note that if the CODE is 00h, then this command operates the same as STORE\_DEFAULT\_ALL.

CODE = 00h	Copy RAM OPERATING to flash MAIN
CODE = 01h	Copy RAM OPERATING to flash BACKUP
CODE = 02h	Copy RAM TEMPORARY to flash MAIN
CODE = 03h	Copy RAM TEMPORARY to flash BACKUP

When the MFR\_STORE\_ALL command is invoked, the device is unresponsive to PMBus commands and does not monitor power supplies while transferring the configuration. The time required to complete this task is listed in the [Electrical Characteristics](#). The MFR\_STORE\_SINGLE command allows a single command to be stored in much less time.

**USER NOTE:  $V_{DD}$  must be above 2.9V for the device to perform the MFR\_STORE\_ALL command.**

### MFR\_RESTORE\_ALL (EFh)

The MFR\_RESTORE\_ALL command instructs the device to copy either the flash MAIN memory array or the flash BACKUP memory array to either RAM OPERATING or RAM TEMPORARY. Which transfer is to occur is determined by the CODE. This command is write-only. There is one data byte for this command which is the CODE. Only CODE values of 00h–03h are valid; all other CODE values are ignored. Note that if the CODE is 00h, then this command operates the same as RESTORE\_DEFAULT\_ALL.

The MFR\_RESTORE\_ALL command should only be executed when the device is not operating the power supplies.

CODE = 00h	Copy flash MAIN to RAM OPERATING
CODE = 01h	Copy flash BACKUP to RAM OPERATING
CODE = 02h	Copy flash MAIN to RAM TEMPORARY
CODE = 03h	Copy flash BACKUP to RAM TEMPORARY

When MFR\_RESTORE\_ALL is issued, the data is checked for validity before being transferred. If the MAIN array is corrupt, the device sets bit 1 of STATUS\_CML. If the BACKUP array is corrupt, the device sets bit 2 of STATUS\_CML. No other action is taken by the device. To resolve the data corruption, the configuration data must be written to RAM OPERATING and STORE\_DEFAULT\_ALL or MFR\_STORE\_ALL must be issued.

### MFR\_STORE\_SINGLE (FCh)

The MFR\_STORE\_SINGLE is a read/write word command that instructs the device to transfer a single configuration parameter from RAM OPERATING to the flash SINGLE memory array. The upper byte contains the page and the lower byte contains the PMBus command that should be stored. For example, if the TON\_DELAY parameter for the power supply controlled by PAGE 4 needs to be stored to flash, 0460h would be written with this command. When read, this command reports the last single page/command written to flash. This command can be used while the device is operating the power supplies. If an error occurs during the transfer, **ALERT** asserts if enabled and the CML bit in STATUS\_WORD is set to 1. No bits are set in STATUS\_CML. The MFR\_STORE\_SINGLE command should only be invoked a maximum of 85 times before either a device reset is issued, or a device power cycle occurs, or the RESTORE\_DEFAULT\_ALL command is invoked. Once the MFR\_STORE\_SINGLE command is invoked, the STORE\_DEFAULT\_ALL and MFR\_STORE\_ALL commands should not be used until either a device reset is issued, or a device power cycle occurs, or the RESTORE\_DEFAULT\_ALL command is invoked. Also, MFR\_STORE\_SINGLE should not be used for commands that are not stored in flash. See [Table 3](#) for a list of commands that are stored in flash.

**USER NOTE:  $V_{DD}$  must be above 2.9V for the device to perform the MFR\_STORE\_SINGLE command.**

**MFR\_CRC (FEh)**

The MFR\_CRC is a read/write word command that instructs the device to report the calculated 16-bit CRC value of either the RAM OPERATING or RAM TEMPORARY or flash MAIN or flash BACKUP memory arrays. A CRC value for the flash SINGLE array is not available. Only one 16-bit CRC is reported with each read of MFR\_CRC. Which CRC value to be reported is determined by the most previous written CODE value as shown in the [Table 16](#). For example, if MFR\_CRC is first written with a CODE of 0001h, then the next read of MFR\_CRC reports the CRC for the flash BACKUP array. If no CODE value is written, MFR\_CRC returns FFFFh when read.

**CAPABILITY (19h)**

The CAPABILITY command is used to determine some key capabilities of the device. The CAPABILITY command is read-only. The message content is described in [Table 17](#).

**VOUT\_MODE (20h)**

The VOUT\_MODE command is used to report the data format of the device. The device uses the DIRECT format for all the voltage-related commands. The value returned is 40h, indicating DIRECT data format. This command is

**Table 16. MFR\_CRC (FEh) Command Byte**

MFR_CRC CODE VALUE	MEMORY ARRAY CRC VALUE TO BE REPORTED ON NEXT READ OF MFR_CRC
0000h	Flash MAIN
0001h	Flash BACKUP
0002h	RAM OPERATING
0003h	RAM TEMPORARY

**Table 17. CAPABILITY (19h) Command Byte**

BIT	NAME	MEANING
7	Packet-error checking	0 = PEC not supported.
6:5	PMBus speed	01 = Maximum supported bus speed is 400kHz.
4	ALERT	1 = Device supports an $\overline{\text{ALERT}}$ output (ALERT is enabled in MFR_MODE). 0 = Device does not support ALERT output (ALERT is disabled in MFR_MODE).
3:0	Reserved	Always returns 0000.

read-only. If a host attempts to write this command, the CML status bit is asserted. See [Table 5](#) for the m, b, and R values for the various commands.

**VOUT\_COMMAND (21h)**

The VOUT\_COMMAND command loads the device with the voltage to which the power-supply output is to be changed to after all other power supplies in the sequence group are powered up. The device adjusts the power-supply voltage by enabling the associated DAC output and actively close-loop margining the power-supply output voltage. After all the power supplies are powered up, the device loads the onboard DAC with the DAC value in the MFR\_MARGIN\_CONFIG command, and begins to margin the power-supply output voltage up or down as needed. This margining runs continuously as long as the power supply is enabled. If margining is enabled using the OPERATION command, then the VOUT\_COMMAND is overridden and the power supply is driven to the voltage as configured in the VOUT\_MARGIN\_HIGH or VOUT\_MARGIN\_LOW command. If VOUT\_COMMAND is set to 0000h, the VOUT\_COMMAND is disabled and no active power-supply output voltage adjustment is done and the DAC output remains high impedance. The VOUT\_COMMAND should only be changed when the power supplies are turned off. The 2 data bytes are in DIRECT format. If the device cannot successfully close-loop margin the power supply, the device keeps attempting to margin the supply and does the following:

- 1) Sets the MARGIN bit in STATUS\_WORD.
- 2) Sets the MARGIN\_FAULT bit in STATUS\_MFR\_SPECIFIC (PAGES 0 to 15).
- 3) Notifies the host through  $\overline{\text{ALERT}}$  assertion (if enabled in MFR\_MODE).

**VOUT\_MARGIN\_HIGH (25h)**

The VOUT\_MARGIN\_HIGH command loads the device with the voltage to which the power-supply output is to be changed when the OPERATION command is set to margin high. If the power supply is already operating at margin high, changing VOUT\_MARGIN\_HIGH has no effect on the output voltage. The device only adjusts the power supply to the new VOUT\_MARGIN\_HIGH voltage after receiving a new margin high OPERATION command. The 2 data bytes are in DIRECT format. If the device cannot successfully close-loop margin the power supply, the device keeps attempting to margin the supply and does the following:

- 1) Sets the MARGIN bit in STATUS\_WORD.
- 2) Sets the MARGIN\_FAULT bit in STATUS\_MFR\_SPECIFIC (PAGES 0 to 15).
- 3) Notifies the host through  $\overline{\text{ALERT}}$  assertion (if enabled in MFR\_MODE).

**VOUT\_MARGIN\_LOW (26h)**

The VOUT\_MARGIN\_LOW command loads the device with the voltage to which the power-supply output is to be changed when the OPERATION command is set to margin low. If the power supply is already operating at margin low, changing VOUT\_MARGIN\_LOW has no effect on the output voltage. The device only adjusts the power supply to the new VOUT\_MARGIN\_LOW voltage after receiving a new margin low OPERATION command. The 2 data bytes are in DIRECT format. If the device cannot successfully close-loop margin the power supply, the device keeps attempting to margin the supply and does the following:

- 1) Sets the MARGIN bit in STATUS\_WORD.

- 2) Sets the MARGIN\_FAULT bit in STATUS\_MFR\_SPECIFIC (PAGES 0 to 15).
- 3) Notifies the host through  $\overline{\text{ALERT}}$  assertion (if enabled in MFR\_MODE).

**VOUT\_SCALE\_MONITOR (2Ah)**

In applications where the measured power-supply voltage is not equal to the voltage at the ADC input, VOUT\_SCALE\_MONITOR is used. For example, if the ADC input expects a 1.8V input for a 12V output,  $\text{VOUT\_SCALE\_MONITOR} = 1.8\text{V}/12\text{V} = 0.15$ . In applications where the power-supply output voltage is greater than the MAX34462 input range of 2.048V, the output voltage of the power supply is sensed through a resistive voltage-divider. The resistive voltage divider reduces or scales the output voltage. The PMBus commands specify the actual power-supply output voltages and not the input voltage to the ADC. To allow the device to map between the high power-supply voltages (such as 12V) and the voltage at the ADC input, the VOUT\_SCALE\_MONITOR command is used. The 2 data bytes are in DIRECT format. This value is dimensionless. As an example, if the required scaling factor is 0.15, then VOUT\_SCALE\_MONITOR should be set to 1333h ( $4915/32767 = 0.15$ ). See [Table 18](#).

**USER NOTE: The device's full-scale ADC voltage is 2.048V. A scaling factor where a 1.8V ADC input represents a nominal 100% voltage level is recommended to allow headroom for margining. Resistor-dividers must be used to measure voltage greater than 1.8V. The maximum source impedance of the resistor divider is limited by the setting of the ADC\_TIME bits in MFR\_MODE. See the [Recommended Operating Conditions](#) section for details.**

**Table 18. VOUT\_SCALE\_MONITOR (2Ah) Examples**

NOMINAL VOLTAGE LEVEL MONITORED	NOMINAL ADC INPUT VOLTAGE LEVEL	RESISTIVE DIVIDER RATIO	VOUT_SCALE_MONITOR VALUE
1.8V or less	1.8V	1.0	7FFFh
2.5V	1.8V	0.72	5C28h
3.3V	1.8V	0.545454	45D1h
5V	1.8V	0.36	2E14h
12V	1.8V	0.15	1333h

**IOUT\_CAL\_GAIN (38h)**

The IOUT\_CAL\_GAIN command is used to set the ratio of the voltage at the ADC input to the sensed current. The units of the IOUT\_CAL\_GAIN factor are 0.1mΩ. The 2 data bytes are in DIRECT format. As an example, if a 10mΩ sense resistor is used in conjunction with a 50V/V current sense amplifier, the IOUT\_CAL\_GAIN should be set to 500mΩ or 1388h.

**USER NOTE: The device's full-scale ADC voltage is 2.048V. The value of the sense resistor and current-sense amplifier gain must be scaled appropriately. Also, the maximum voltage at the RS inputs must be less than 4V. The maximum output impedance of the current sense amplifier is limited by the setting of the ADC\_TIME bits in MFR\_MODE. See the [Recommended Operating Conditions](#) section for details.**

**VOUT\_OV\_FAULT\_LIMIT (40h)**

The VOUT\_OV\_FAULT\_LIMIT command sets the value of the output voltage which causes an output overvoltage fault. The monitored voltage must drop by at least 2% below the limit before the fault is allowed to clear. The 2 data bytes are in DIRECT format. In response to the VOUT\_OV\_FAULT\_LIMIT being exceeded, the device does the following:

- 1) Sets the VOUT\_OV bit and the VOUT bit in STATUS\_WORD.
- 2) Sets the VOUT\_OV\_FAULT bit in STATUS\_VOUT.
- 3) Responds as specified in the MFR\_FAULT\_RESPONSE.
- 4) Notifies the host through  $\overline{\text{ALERT}}$  assertion (if enabled in MFR\_MODE).

**VOUT\_OV\_WARN\_LIMIT (42h)**

The VOUT\_OV\_WARN\_LIMIT command sets the value of the output voltage which causes an output voltage high warning. The monitored voltage must drop by at least 2% below the limit before the warning is allowed to clear. This value is typically less than the output overvoltage threshold in VOUT\_OV\_FAULT\_LIMIT. The 2 data bytes are in DIRECT format. In response to the VOUT\_OV\_WARN\_LIMIT being exceeded, the device does the following:

- 1) Sets the VOUT bit in STATUS\_WORD.
- 2) Sets the VOUT\_OV\_WARN bit in STATUS\_VOUT.
- 3) Notifies the host using  $\overline{\text{ALERT}}$  assertion (if enabled in MFR\_MODE).

**VOUT\_UV\_WARN\_LIMIT (43h)**

The VOUT\_UV\_WARN\_LIMIT command sets the value of the output voltage which causes an output-voltage low

warning. The monitored voltage must increase by at least 2% above the limit before the warning is allowed to clear. This value is typically greater than the output undervoltage fault threshold in VOUT\_UV\_FAULT\_LIMIT. This warning is masked until the output voltage reaches the programmed POWER\_GOOD\_ON for the first time and also during turn-off when the power supply is disabled. If the voltage is being monitored, this should be set to a value greater than 100mV. The 2 data bytes are in DIRECT format. In response to violation of the VOUT\_UV\_WARN\_LIMIT, the device does the following:

- 1) Sets the VOUT bit in STATUS\_WORD.
- 2) Sets the VOUT\_UV\_WARN bit in STATUS\_VOUT.
- 3) Notifies the host using  $\overline{\text{ALERT}}$  assertion (if enabled in MFR\_MODE).

**VOUT\_UV\_FAULT\_LIMIT (44h)**

The VOUT\_UV\_FAULT\_LIMIT command sets the value of the output voltage which causes an output undervoltage fault. The monitored voltage must increase by at least 2% above the limit before the fault is allowed to clear. This fault is masked until the output voltage reaches the programmed POWER\_GOOD\_ON for the first time and also during turn-off when the power supply is disabled. If the voltage is being monitored, this should be set to a value greater than 100mV. The 2 data bytes are in DIRECT format. In response to violation of the VOUT\_UV\_FAULT\_LIMIT, the device does the following:

- 1) Sets the VOUT bit in STATUS\_WORD.
- 2) Sets the VOUT\_UV\_FAULT bit in STATUS\_VOUT.
- 3) Responds as specified in MFR\_FAULT\_RESPONSE.
- 4) Notifies the host using  $\overline{\text{ALERT}}$  assertion (if enabled in MFR\_MODE).

**IOUT\_OC\_WARN\_LIMIT (46h)**

The IOUT\_OC\_WARN\_LIMIT command sets the value of the current which causes an overcurrent warning. The monitored current must decrease by at least 5% below the limit before the warning is allowed to clear. This value is typically less than the overcurrent fault threshold in IOUT\_OC\_FAULT\_LIMIT. The 2 data bytes are in DIRECT format. In response to violation of the IOUT\_OC\_WARN\_LIMIT, the device does the following:

- 1) Sets the IOUT bit in STATUS\_WORD.
- 2) Sets the IOUT\_OC\_WARN bit in STATUS\_IOUT.
- 3) Notifies the host using  $\overline{\text{ALERT}}$  assertion (if enabled in MFR\_MODE).

**IOUT\_OC\_FAULT\_LIMIT (4Ah)**

The IOUT\_OC\_FAULT\_LIMIT command sets the value of the current which causes an overcurrent fault. The monitored current must decrease by at least 5% below the limit before the fault is allowed to clear. This fault is masked until the current is below this limit for the first time. The 2 data bytes are in DIRECT format. In response to violation of the IOUT\_OC\_FAULT\_LIMIT, the device does the following:

- 1) Sets the IOUT bit in STATUS\_WORD.
- 2) Sets the IOUT\_OC\_FAULT bit in STATUS\_IOUT.
- 3) Responds as specified in the MFR\_FAULT\_RESPONSE.
- 4) Notifies the host using  $\overline{\text{ALERT}}$  assertion (if enabled in MFR\_MODE).

**OT\_FAULT\_LIMIT (4Fh)**

The OT\_FAULT\_LIMIT command sets the temperature, in degrees Celsius, of the selected temperature sensor at which an overtemperature fault is detected. The monitored temperature must drop by at least 4°C below the limit before the fault is allowed to clear. The 2 data bytes are in DIRECT format. In response to the OT\_FAULT\_LIMIT being exceeded, the device does the following:

- 1) Sets the TEMPERATURE bit in STATUS\_WORD.
- 2) Sets the OT\_FAULT bit in STATUS\_TEMPERATURE register.
- 3) Responds as specified in the MFR\_FAULT\_RESPONSE.
- 4) Notifies the host using  $\overline{\text{ALERT}}$  assertion (if enabled in MFR\_MODE).

**OT\_WARN\_LIMIT (51h)**

The OT\_WARN\_LIMIT command sets the temperature, in degrees Celsius, of the selected temperature sensor at which an overtemperature warning is detected. The monitored temperature must drop by at least 4°C below the limit before the warning is allowed to clear. The 2 data bytes are in DIRECT format. In response to the OT\_WARN\_LIMIT being exceeded, the device does the following:

- 1) Sets the TEMPERATURE bit in STATUS\_WORD.
- 2) Sets the OT\_WARN bit in STATUS\_TEMPERATURE register.
- 3) Notifies the host through  $\overline{\text{ALERT}}$  assertion (if enabled in MFR\_MODE).

**POWER\_GOOD\_ON (5Eh)**

The POWER\_GOOD\_ON command sets the value of the output voltage which the channel must exceed

for a power-good state to be declared on this channel. All power supplies must also be above POWER\_GOOD\_ON for power-supply margining to begin. The POWER\_GOOD\_ON threshold is also used to determine if the TON\_MAX\_FAULT\_LIMIT is exceeded. The POWER\_GOOD\_ON level is normally set higher than the POWER\_GOOD\_OFF level. The 2 data bytes are in DIRECT format.

**POWER\_GOOD\_OFF (5Fh)**

The POWER\_GOOD\_OFF command sets the value of the output voltage which causes the power-good state on this channel to deassert after it has been asserted. The POWER\_GOOD\_OFF level is normally set lower than the POWER\_GOOD\_ON level. The 2 data bytes are in DIRECT format.

When the VOUT level of a power supply falls from greater than POWER\_GOOD\_ON to less than POWER\_GOOD\_OFF, the device does the following:

- 1) Sets the POWER\_GOOD# in STATUS\_WORD.
- 2) Sets the POWER\_GOOD# bit in STATUS\_MFR\_SPECIFIC register (PAGES 0 to 15).

**TON\_DELAY (60h)**

In the PMBus sequencing configuration, TON\_DELAY sets the time, in milliseconds, from when a start condition is received until the PSEN output is asserted. If the PSEN/GPO output has been configured (with the MFR\_PSEN\_CONFIG command) as a PG/GPI or ALARM pin, then this command can be used to delay the assertion of the output. The 2 data bytes are in DIRECT format.

**TOFF\_DELAY (64h)**

The TOFF\_DELAY sets the time, in milliseconds, from when a stop condition is received (a soft-off OPERATION command or through the CONTROL0/1/2/3 pins when enabled) until the PSEN output is deasserted. When commanded to turn off immediately (either through the OPERATION command or the CONTROL0/1/2/3 pins), the TOFF\_DELAY value is ignored. If the PSEN/GPO output has been configured (with the MFR\_PSEN\_CONFIG command) as a PG/GPI or ALARM pin, then this command can be used to delay the deassertion of the output. The 2 data bytes are in DIRECT format.

**USER NOTE: When TON\_DELAY and TOFF\_DELAY are used to delay the PSEN/GPO outputs for power-good or alarm signals, the actual time delays are 2ms to 3ms longer than configured due to processing delays within the device.**

**TON\_MAX\_FAULT\_LIMIT (62h)**

The TON\_MAX\_FAULT\_LIMIT sets an upper time limit, in milliseconds, from when the PSEN output is asserted until the output voltage crosses the POWER\_GOOD\_ON threshold. The 2 data bytes are in DIRECT format. If the value is zero, then the limit is disabled. In response to the TON\_MAX\_FAULT\_LIMIT being exceeded, the device does the following:

1) Sets the VOUT bit in STATUS\_WORD.

2) Sets the TON\_MAX\_FAULT bit in STATUS\_VOUT.

3) Responds as specified in the MFR\_FAULT\_RESPONSE.

4) Notifies the host using  $\overline{\text{ALERT}}$  assertion (if enabled in MFR\_MODE).

**STATUS\_WORD (79h)**

The STATUS\_WORD command returns 2 bytes of information with a summary of the reason for a fault. The STATUS\_WORD message content is described in [Table 19](#).

**Table 19. STATUS\_WORD (79h)**

BIT	NAME	MEANING
15	VOUT	An output voltage fault or warning, or TON_MAX_FAULT_LIMIT or MFR_TON_SEQ_MAX has occurred.
14	IOUT	An overcurrent fault or warning has occurred.
13	0	This bit always returns a 0.
12	MFR	A bit in STATUS_MFR_SPECIFIC (PAGE = 255) has been set.
11	POWER_GOOD#	Any power-supply voltage has fallen from POWER_GOOD_ON to less than POWER_GOOD_OFF (logical OR of all the POWER_GOOD# bits in STATUS_MFR_SPECIFIC).
10:9	0	These bits always return a 0.
8	MARGIN	A margining fault has occurred.
7	0	This bit always returns a 0.
6	SYS_OFF	Set when any of the power supplies are sequenced off (logical OR of all the OFF bits in STATUS_MFR_SPECIFIC).
5	VOUT_OV	An overvoltage fault has occurred.
4	IOUT_OC	An overcurrent fault has occurred.
3	0	This bit always returns a 0.
2	TEMPERATURE	A temperature fault or warning has occurred.
1	CML	A communication, memory, or logic fault has occurred.
0	0	This bit always returns a 0.

**Note:** The setting of the SYS\_OFF and POWER\_GOOD# bits do not assert the  $\overline{\text{ALERT}}$  signal.

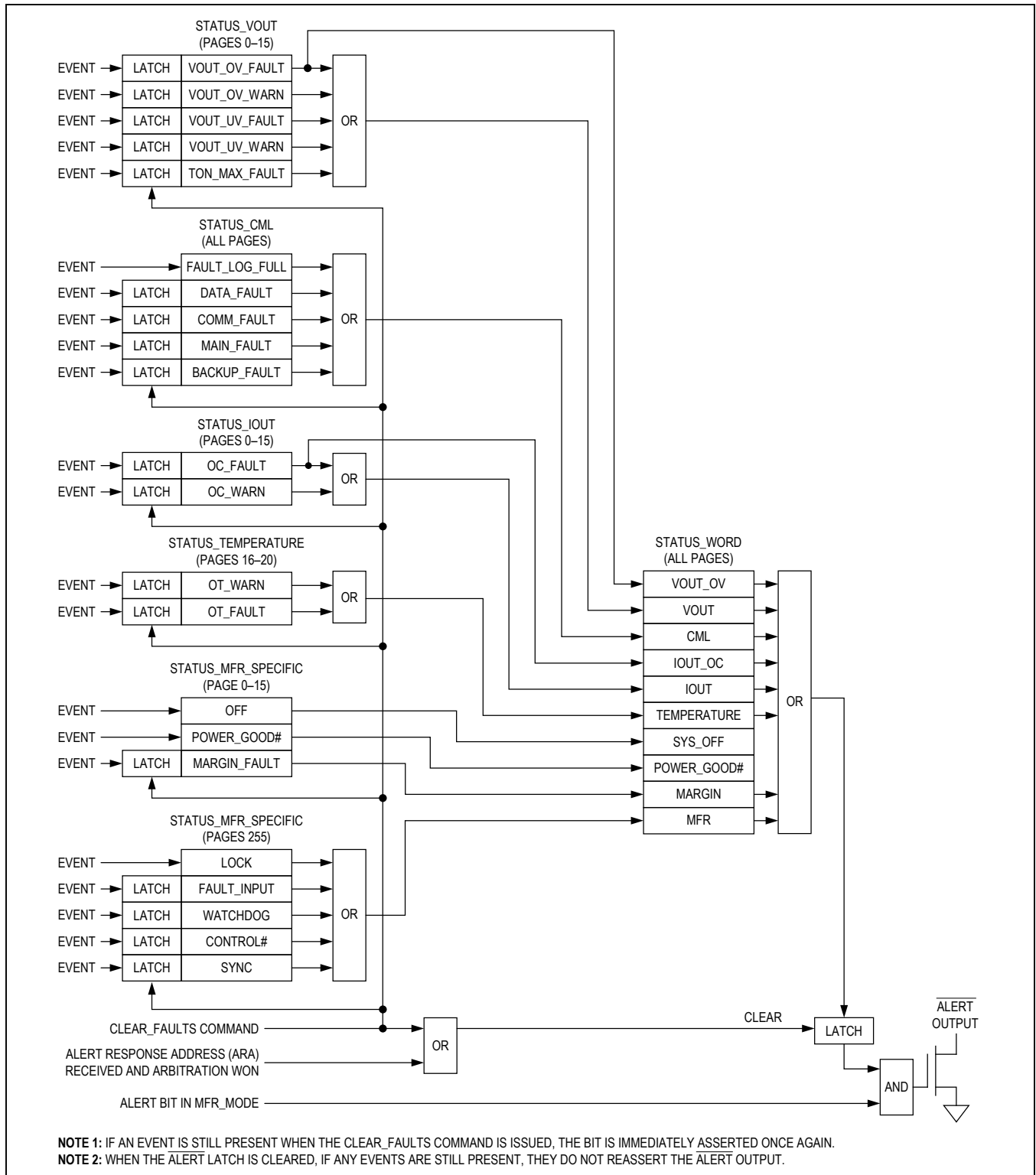

Figure 7. Status Register Organization

**STATUS\_VOUT (7Ah)**

The STATUS\_VOUT command returns one byte of information with contents as described in [Table 20](#). All the bits in STATUS\_VOUT are latched. When cleared, the bits are set again if the condition persists or in the case of TON\_MAX\_FAULT, when the event occurs again.

**STATUS\_IOUT (7Bh)**

The STATUS\_IOUT command returns one byte of information with contents as described in [Table 21](#). All the bits

in STATUS\_IOUT are latched. When cleared, the bits are set again if the condition persists.

**STATUS\_TEMPERATURE (7Dh)**

The STATUS\_TEMPERATURE command returns one byte of information with contents as described in [Table 22](#). All the bits in STATUS\_VOUT are latched. When cleared, the bits are set again if the condition persists.

**Table 20. STATUS\_VOUT (7Ah)**

BIT	NAME	MEANING	LATCHED
7	VOUT_OV_FAULT	VOUT overvoltage fault.	Yes
6	VOUT_OV_WARN	VOUT overvoltage warning.	Yes
5	VOUT_UV_WARN	VOUT undervoltage warning.	Yes
4	VOUT_UV_FAULT	VOUT undervoltage fault.	Yes
3	0	This bit always returns a 0.	—
2	TON_MAX_FAULT	TON maximum fault or MFR_TON_SEQ_MAX fault.	Yes
1:0	0	These bits always return a 0.	—

**Table 21. STATUS\_IOUT (7Bh)**

BIT	NAME	MEANING	LATCHED
7	IOUT_OC_FAULT	IOUT overcurrent fault.	Yes
6	0	This bit always returns a 0.	—
5	IOUT_OC_WARN	IOUT overcurrent warning.	Yes
4:0	0	These bits always return a 0.	—

**Table 22. STATUS\_TEMPERATURE (7Dh)**

BIT	NAME	MEANING	LATCHED
7	OT_FAULT	Overtemperature fault.	Yes
6	OT_WARN	Overtemperature warning.	Yes
5:0	0	These bits always return a 0.	—

**STATUS\_CML (7Eh)**

The STATUS\_CML command returns one byte of information with contents as described in [Table 23](#). The COMM\_FAULT, DATA\_FAULT, MAIN\_FAULT, and BACKUP\_FAULT bits are latched. When cleared, the bits are set again when the event occurs again. The FAULT\_LOG\_FULL bit reflects the current real-time state of the fault log.

**STATUS\_MFR\_SPECIFIC (80h)**

The STATUS\_MFR\_SPECIFIC message content varies based on the selected PAGE and it is described in [Table 24](#) and [Table 25](#).

**Table 23. STATUS\_CML (7Eh)**

BIT	NAME	MEANING	LATCHED
7	COMM_FAULT	An invalid or unsupported command has been received.	Yes
6	DATA_FAULT	An invalid or unsupported data has been received.	Yes
5:3	0	These bits always return a 0.	—
2	BACKUP_FAULT	Flash BACKUP memory array is corrupt.	Yes
1	MAIN_FAULT	Flash MAIN memory array is corrupt.	Yes
0	FAULT_LOG_FULL	MFR_NV_FAULT_LOG is full and needs to be cleared.	No

**Note 1:** When NV fault log overwrite is enabled (NV\_LOG\_OVERWRITE = 1 in MFR\_MODE), FAULT\_LOG\_FULL is set when the fault log is full, but clears when the fault log is overwritten since two fault logs are cleared before each overwrite.

**Note 2:** The setting of the BACKUP\_FAULT and MAIN\_FAULT bits do not assert the ALERT signal.

**Table 24. STATUS\_MFR\_SPECIFIC (80h) (for PAGES 0 to 15)**

BIT	NAME	MEANING	LATCHED
7	OFF	For enabled channels, this bit reflects the output state of the sequencer and is set when PSEN is not asserted due to either a sequencing delay or a fault, or the power supply being turned off. This bit is always cleared when the channel is disabled. If PSEN is reconfigured as a GPO, this bit does not reflect the state of the pin (Note 1).	No
6:4	0	These bits always return a 0.	—
3	MARGIN_FAULT	This bit is set if the device cannot properly close-loop margin the power supply.	Yes
2	POWER_GOOD#	This bit is set when the power-supply voltage has fallen from POWER_GOOD_ON to less than POWER_GOOD_OFF. On device reset, this bit is set until the power supply is greater than POWER_GOOD_ON (Notes 1 and 2).	No
1:0	0	These bits always return a 0.	—

**Note 1:** The setting of the OFF and POWER\_GOOD# bits do not assert the  $\overline{\text{ALERT}}$  signal.

**Note 2:** When an input channel is configured as a GPI input using the MFR\_CHANNEL\_CONFIG command, the POWER\_GOOD# bit is set when the GPI input is deasserted.

**Table 25. STATUS\_MFR\_SPECIFIC (80h) (for PAGE 255)**

BIT	NAME	MEANING	LATCHED
7	LOCK	Set when the device is password protected (Note 1).	No
6	FAULT_INPUT	Set each time any of the $\overline{\text{FAULT}}$ inputs is pulled low (Note 2).	Yes
5	0	This bit always returns a 0.	—
4	WATCHDOG_INT	Set upon device reset when the internal watchdog has caused the device reset.	Yes
3	CONTROL#	Set each time the CONTROL0/1/2/3 inputs are deasserted (Note 3).	Yes
2:1	0	These bits always return a 0.	—
0	SYNC	Set when the SYNC input (slave mode only) is not toggling.	Yes

**Note 1:** The setting of the LOCK bit does not assert the  $\overline{\text{ALERT}}$  signal.

**Note 2:** Applies to all  $\overline{\text{FAULT}}$  inputs. The FAULT status bit is set even if the  $\overline{\text{FAULT}}$  pin is configured in MFR\_NV\_LOG\_CONFIG to ignore the  $\overline{\text{FAULT}}$  pins. If a  $\overline{\text{FAULT}}$  pin is used as a GPO, it does not affect this bit.

**Note 3:** Any CONTROL pin can set this bit. ON\_OFF\_CONFIG must be configured to use the CONTROL0/1/2/3 pins for this status bit to function.

### READ\_VOUT (8Bh)

The READ\_VOUT command returns the actual measured (not commanded) output voltage. READ\_VOUT is measured and updated every 5ms. If the RS/GPI is configured to be a general-purpose input (GPI) by configuring the SELECT bits in MFR\_CHANNEL\_CONFIG to either 30h or 34h, then READ\_VOUT reports 0000h when the GPI input is inactive and 0001h when the GPI input is active. The 2 data bytes are in DIRECT format.

### READ\_IOUT (8Ch)

The READ\_IOUT command returns the latest measured current value. READ\_IOUT is measured and updated every 5ms. The 2 data bytes are in DIRECT format.

### READ\_TEMPERATURE\_1 (8Dh)

The READ\_TEMPERATURE\_1 command returns the temperature returned from the temperature sensor. READ\_TEMPERATURE\_1 returns 7FFFh if the sensor is faulty and 0000h if the sensor is disabled. READ\_TEMPERATURE\_1 is measured and updated once a second. The 2 data bytes are in DIRECT format.

### PMBUS\_REVISION (98h)

The PMBUS\_REVISION command returns the revision of the PMBus specification to which the device is compliant. The command has 1 data byte. Bits [7:4] indicate the revision of PMBus specification Part I to which the device is compliant. Bits [3:0] indicate the revision of PMBus

specification Part II to which the device is compliant. This command is read-only. The PMBUS\_REVISION value returned is always 11h which indicates that the device is compliant with Part I Rev 1.1 and Part II Rev 1.1.

### MFR\_ID (99h)

The MFR\_ID command returns the text (ISO/IEC 8859-1) character of the manufacturer's (Maxim) identification. The default MFR\_ID value is 4Dh (M). This command is read-only.

### MFR\_MODEL (9Ah)

The MFR\_MODEL command returns the text (ISO/IEC 8859-1) character of the device model number. The default MFR\_MODEL value is 5Ah (Z). This command is read-only.

### MFR\_REVISION (9Bh)

The MFR\_REVISION command returns two text (ISO/IEC 8859-1) characters that contain the device revision numbers for hardware (upper byte) and firmware (lower byte). This command is read-only.

### MFR\_LOCATION (9Ch)

The MFR\_LOCATION command loads the device with text (ISO/IEC 8859-1) characters that identify the facility that manufactures the power supply. The maximum number of characters is 8. This data is written to internal flash using the STORE\_DEFAULT\_ALL command. The factory-default text string value is 10101010.

**MFR\_DATE (9Dh)**

The MFR\_DATE command loads the device with text (ISO/IEC 8859-1) characters that identify the date of manufacture of the power supply. The maximum number of characters is 8. This data is written to internal flash using the STORE\_DEFAULT\_ALL command. The factory default text string value is 10101010.

**MFR\_SERIAL (9Eh)**

The MFR\_SERIAL command loads the device with text (ISO/IEC 8859-1) characters that uniquely identify the device. The maximum number of characters is 8.

This data is written to internal flash using the STORE\_DEFAULT\_ALL command. The factory default text string value is 10101010. The upper 4 bytes of MFR\_SERIAL are used to unlock a device that has been password protected. The lower 4 bytes of MFR\_SERIAL are not used to unlock a device and they can be set to any value.

**MFR\_MODE (D1h)**

The MFR\_MODE command is used to configure the device to support manufacturer specific commands. The MFR\_MODE command should not be changed while power supplies are operating. The MFR\_MODE command is described in [Table 26](#).

**Table 26. MFR\_MODE (D1h)**

BIT	NAME	MEANING																																				
15:14	0	These bits always return a 0.																																				
13	ALERT	0 = $\overline{\text{ALERT}}$ disabled (device does not respond to ARA). 1 = $\overline{\text{ALERT}}$ enabled (device does respond to ARA).																																				
12	SYNC	SYNC pin select. 0 = Master (SYNC pin outputs a 20kHz clock) 1 = Slave (SYNC pin inputs a 20kHz clock)																																				
11	SOFT_RESET	This bit must be set, then cleared and set again within 8ms for a soft reset to occur.																																				
10	LOCK	This bit must be set, then cleared and set again within 8ms for the device to become password protected. This bit is cleared when the password is unlocked. <b>The device should only be locked and then unlocked a maximum of 256 times before either a device reset is issued or a device power cycle occurs.</b>																																				
9:8	0	These bits always return a 0.																																				
7:6	ADC_TIME[1:0]	These bits select the ADC conversion time: <table style="margin-left: auto; margin-right: auto;"> <thead> <tr> <th>ADC_TIME[1:0]</th> <th>ADC CONVERSION TIME</th> </tr> </thead> <tbody> <tr> <td>00</td> <td>1<math>\mu</math>s</td> </tr> <tr> <td>01</td> <td>2<math>\mu</math>s</td> </tr> <tr> <td>10</td> <td>4<math>\mu</math>s</td> </tr> <tr> <td>11</td> <td>8<math>\mu</math>s</td> </tr> </tbody> </table>	ADC_TIME[1:0]	ADC CONVERSION TIME	00	1 $\mu$ s	01	2 $\mu$ s	10	4 $\mu$ s	11	8 $\mu$ s																										
ADC_TIME[1:0]	ADC CONVERSION TIME																																					
00	1 $\mu$ s																																					
01	2 $\mu$ s																																					
10	4 $\mu$ s																																					
11	8 $\mu$ s																																					
5:4	ADC_AVERAGE[1:0]	These bits select the post ADC conversion averaging: <table style="margin-left: auto; margin-right: auto;"> <thead> <tr> <th>ADC_AVERAGE[1:0]</th> <th>ADC AVERAGING</th> </tr> </thead> <tbody> <tr> <td>00</td> <td>No Averaging</td> </tr> <tr> <td>01</td> <td>Average 2 Samples</td> </tr> <tr> <td>10</td> <td>Average 4 Samples</td> </tr> <tr> <td>11</td> <td>Average 8 Samples</td> </tr> </tbody> </table>	ADC_AVERAGE[1:0]	ADC AVERAGING	00	No Averaging	01	Average 2 Samples	10	Average 4 Samples	11	Average 8 Samples																										
ADC_AVERAGE[1:0]	ADC AVERAGING																																					
00	No Averaging																																					
01	Average 2 Samples																																					
10	Average 4 Samples																																					
11	Average 8 Samples																																					
3:0	IOUT_AVG[3:0]	These bits determine the number of samples to average before reporting the value in MFR_IOUT_AVG: <table style="margin-left: auto; margin-right: auto;"> <thead> <tr> <th>IOUT_AVG[3:0]</th> <th>AVERAGING</th> <th>IOUT_AVG[3:0]</th> <th>AVERAGING</th> </tr> </thead> <tbody> <tr> <td>0000</td> <td>1 Sample</td> <td>1000</td> <td>256 Samples</td> </tr> <tr> <td>0001</td> <td>2 Samples</td> <td>1001</td> <td>512 Samples</td> </tr> <tr> <td>0010</td> <td>4 Samples</td> <td>1010</td> <td>1024 Samples</td> </tr> <tr> <td>0011</td> <td>8 Samples</td> <td>1011</td> <td>2048 Samples</td> </tr> <tr> <td>0100</td> <td>16 Samples</td> <td>1100</td> <td>4096 Samples</td> </tr> <tr> <td>0101</td> <td>32 Samples</td> <td>1101</td> <td>8192 Samples</td> </tr> <tr> <td>0110</td> <td>64 Samples</td> <td>1110</td> <td>16,384 Samples</td> </tr> <tr> <td>0111</td> <td>128 Samples</td> <td>1111</td> <td>32,768 Samples</td> </tr> </tbody> </table>	IOUT_AVG[3:0]	AVERAGING	IOUT_AVG[3:0]	AVERAGING	0000	1 Sample	1000	256 Samples	0001	2 Samples	1001	512 Samples	0010	4 Samples	1010	1024 Samples	0011	8 Samples	1011	2048 Samples	0100	16 Samples	1100	4096 Samples	0101	32 Samples	1101	8192 Samples	0110	64 Samples	1110	16,384 Samples	0111	128 Samples	1111	32,768 Samples
IOUT_AVG[3:0]	AVERAGING	IOUT_AVG[3:0]	AVERAGING																																			
0000	1 Sample	1000	256 Samples																																			
0001	2 Samples	1001	512 Samples																																			
0010	4 Samples	1010	1024 Samples																																			
0011	8 Samples	1011	2048 Samples																																			
0100	16 Samples	1100	4096 Samples																																			
0101	32 Samples	1101	8192 Samples																																			
0110	64 Samples	1110	16,384 Samples																																			
0111	128 Samples	1111	32,768 Samples																																			

**MFR\_PSEN\_CONFIG (D2h)**

The MFR\_PSEN\_CONFIG command is used to configure the individual PSENx/GPOx (x = 0 to15) outputs. All the PSEN outputs are open drain and 5V tolerant. This command should not be changed while the power supplies are operating. The MFR\_PSEN\_CONFIG command is described in [Table 27](#) and [Figure 8](#).

Each PSEN/GPO pin can be independently configured using the SELECT[2:0] bits to one of the following:

- Enable and disable power supplies (SELECT[2:0] = 000)
- Force pin assertion (SELECT[2:0] = 001)
- Force pin deassertion (SELECT[2:0] = 010)
- Assert when all enabled channel power-good (PG) or GPI are asserted (SELECT[2:0] = 011)
- Assert when any enabled alarm goes active (SELECT[2:0] = 100)

If the PSEN/GPO output is configured to enable and disable power supplies (SELECT[2:0] = 000), then the associated input channel must also be configured to monitor voltage and to sequence by setting the SELECT bits in MFR\_CHANNEL\_CONFIG to 10h. See the MFR\_CHANNEL\_CONFIG command description for more details.

Also each PSEN/GPO pin can be independently configured to be either active high or active low using the HI\_LO bit.

If SELECT[2:0] = 011, the PSEN/GPO output is configured to assert when some combination of power-goods (PG) and general purpose inputs (GPI) from each channel are asserted. Which channels should be used in this combination are selected using the PG\_GPI\_SELECT bits (bit 16 to 31). If the PG\_GPI\_SELECT bit is cleared, then the associated channel is not used in the logical combination to assert the GPO output. If the PG\_GPI\_SELECT bit is set, then the power-good or GPI from this channel is used in the logical combination to assert the GPO output. This function is useful in creating system power-good signals.

**Table 27. MFR\_PSEN\_CONFIG (D2h)**

BIT	NAME	MEANING																		
31:16	PG_GPI_SELECT ALARM_SELECT	<p>These bits are only used if SELECT[2:0] = 011 or 100. Each bit corresponds to one channel (device channel N + 16 = bit number):</p> <table border="1"> <thead> <tr> <th>SELECT[2:0]</th> <th>BIT FUNCTION</th> </tr> </thead> <tbody> <tr> <td>011</td> <td>When this bit is cleared, the power-good (PG) or GPI from channel N is not used in the logical AND to assert the GPO output. When this bit is set, the PG or GPI is used.</td> </tr> <tr> <td>100</td> <td>When this bit is cleared, the alarm from channel N is blocked from the logical OR to assert the GPO output. When this bit is set, the alarm signal is routed to the logical OR.</td> </tr> </tbody> </table>	SELECT[2:0]	BIT FUNCTION	011	When this bit is cleared, the power-good (PG) or GPI from channel N is not used in the logical AND to assert the GPO output. When this bit is set, the PG or GPI is used.	100	When this bit is cleared, the alarm from channel N is blocked from the logical OR to assert the GPO output. When this bit is set, the alarm signal is routed to the logical OR.												
SELECT[2:0]	BIT FUNCTION																			
011	When this bit is cleared, the power-good (PG) or GPI from channel N is not used in the logical AND to assert the GPO output. When this bit is set, the PG or GPI is used.																			
100	When this bit is cleared, the alarm from channel N is blocked from the logical OR to assert the GPO output. When this bit is set, the alarm signal is routed to the logical OR.																			
15:7	0	These bits always return a 0.																		
6	HI_LO	0 = PSEN/GPO active low 1 = PSEN/GPO active high																		
5:3	0	These bits always return a 0.																		
2:0	SELECT[2:0]	<p>These bits determine the function selected on the pin:</p> <table border="1"> <thead> <tr> <th>SELECT[2:0]</th> <th>PSENn/GPOn PIN FUNCTION SELECTED</th> </tr> </thead> <tbody> <tr> <td>000</td> <td>PSEN operation.*</td> </tr> <tr> <td>001</td> <td>Force GPO assertion.</td> </tr> <tr> <td>010</td> <td>Force GPO deassertion.</td> </tr> <tr> <td>011</td> <td>PG/GPI operation (use bits 31:16).</td> </tr> <tr> <td>100</td> <td>Alarm operation (use bits 31:16).</td> </tr> <tr> <td>101</td> <td>Reserved</td> </tr> <tr> <td>110</td> <td>Reserved.</td> </tr> <tr> <td>111</td> <td>Reserved.</td> </tr> </tbody> </table>	SELECT[2:0]	PSENn/GPOn PIN FUNCTION SELECTED	000	PSEN operation.*	001	Force GPO assertion.	010	Force GPO deassertion.	011	PG/GPI operation (use bits 31:16).	100	Alarm operation (use bits 31:16).	101	Reserved	110	Reserved.	111	Reserved.
SELECT[2:0]	PSENn/GPOn PIN FUNCTION SELECTED																			
000	PSEN operation.*																			
001	Force GPO assertion.																			
010	Force GPO deassertion.																			
011	PG/GPI operation (use bits 31:16).																			
100	Alarm operation (use bits 31:16).																			
101	Reserved																			
110	Reserved.																			
111	Reserved.																			

\*For proper sequencing, the SELECT bits in MFR\_CHANNEL\_CONFIG must be set to 10h.

If SELECT[2:0] = 100, the PSEN/GPO output is configured to assert when any of the enabled channel alarms goes active. The channel alarms are enabled with the ALARM\_SELECT bits (bit 16 to 31). If the ALARM\_SELECT bit is cleared, then the alarm from this channel is blocked. If the ALARM\_SELECT bit is set, then the alarm from this channel is routed to an OR function such that any enabled alarm asserts the GPO output. The alarm function is chosen with

the ALARM\_CONFIG bits in the MFR\_FAULT\_RESPONSE command. This function is useful in system debug or for enabling system status LEDs.

**Delay Function**

If a delay is configured (either on or off), the input must be continuously static through the delay time before the output changes state. See [Figure 9](#).

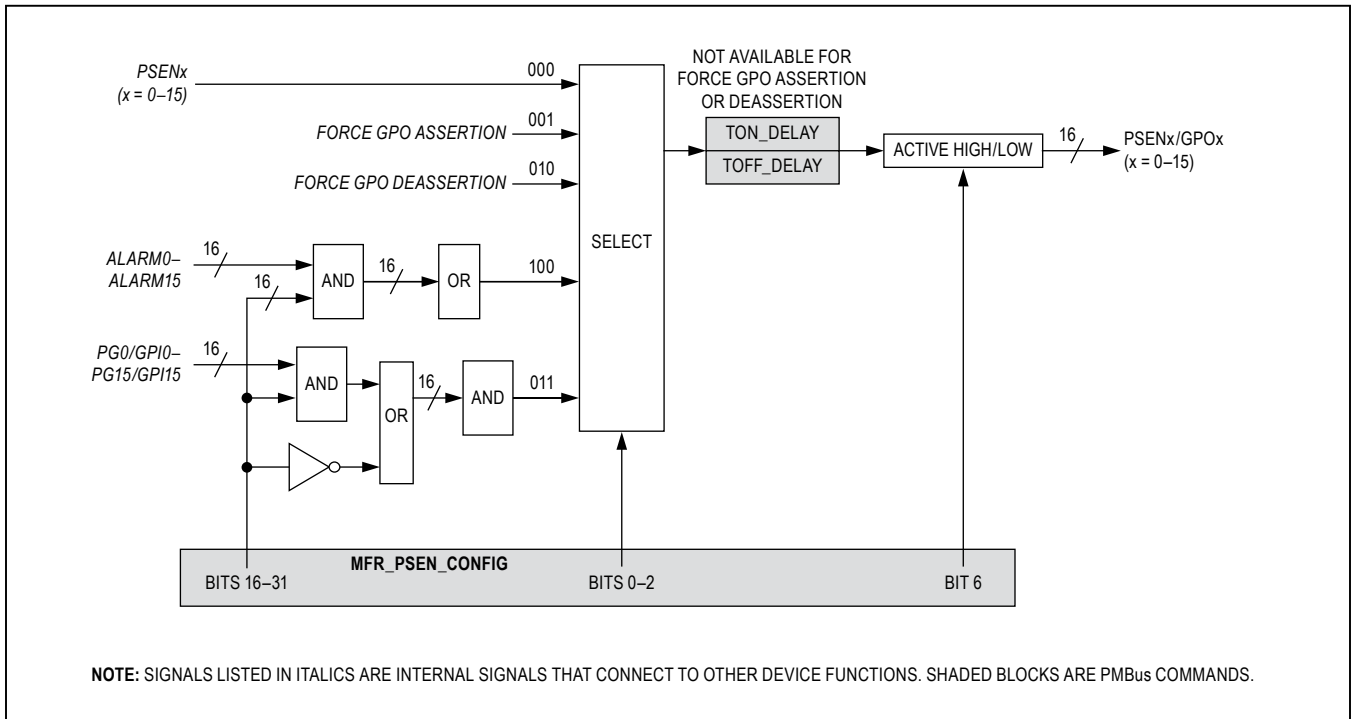

Figure 8. MFR\_PSEN\_CONFIG Functional Logic

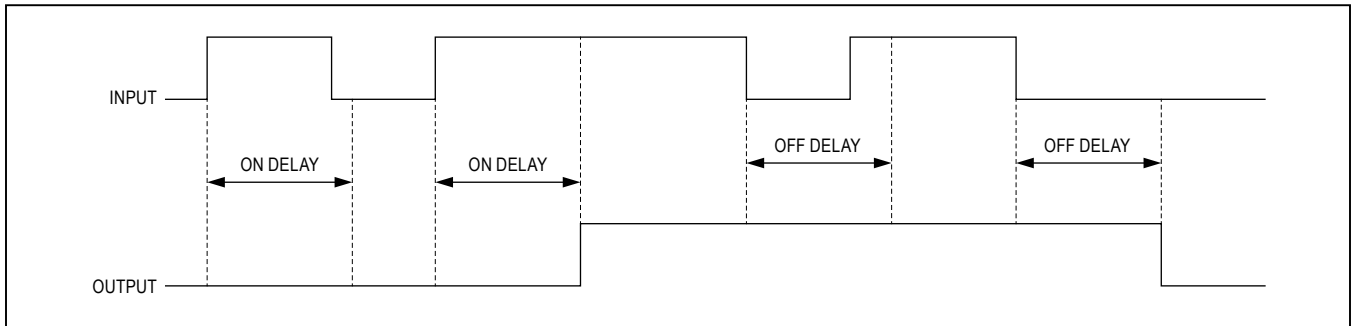

Figure 9. Input to Output Delay Action

**MFR\_VOUT\_PEAK (D4h)**

The MFR\_VOUT\_PEAK command returns the maximum actual measured output voltage. To reset this value to 0, write to this command with a data value of 0. Any values written to this command are used as a comparison for future peak updates. The 2 data bytes are in DIRECT format.

**MFR\_IOUT\_PEAK (D5h)**

The MFR\_IOUT\_PEAK command returns the maximum actual measured current. To reset this value to 0, write to this command with a data value of 0. Any values written to this command are used as a comparison for future peak updates. The 2 data bytes are in DIRECT format.

**MFR\_TEMPERATURE\_PEAK (D6h)**

The MFR\_TEMPERATURE\_PEAK command returns the maximum measured temperature. To reset this value to its lowest value, write to this command with a data value of 8000h. Any other values written by this command are used as a comparison for future peak updates. The 2 data bytes are in DIRECT format.

**MFR\_VOUT\_MIN (D7h)**

The MFR\_VOUT\_MIN command returns the minimum actual measured output voltage. To reset this value, write to this command with a data value of 7FFFh. Any values written to this command are used as a comparison for future minimum updates. The 2 data bytes are in DIRECT format.

**MFR\_IOUT\_AVG (E2h)**

The MFR\_IOUT\_AVG command returns the calculated average current. The number of samples collected in the average before reporting the value in MFR\_IOUT\_AVG is configured using the IOUT\_AVG bits in MFR\_MODE. Writes to this command are ignored. The 2 data bytes are in DIRECT format.

**MFR\_NV\_LOG\_CONFIG (D8h)**

The MFR\_NV\_LOG\_CONFIG command is used to configure the operation of the nonvolatile fault logging in the device. The MFR\_NV\_LOG\_CONFIG command is described in [Table 28](#).

**Table 28. MFR\_NV\_LOG\_CONFIG (D8h)**

BIT	NAME	MEANING															
15	FORCE_NV_FAULT_LOG	Setting this bit to 1 forces the device to log data into the nonvolatile fault log. Once set, the device clears this bit when the action is completed. Host must set again for subsequent action. If an error occurs during this action, the device sets the CML bit in STATUS_WORD; no bits are set in STATUS_CML.															
14	CLEAR_NV_FAULT_LOG	Setting this bit to 1 forces the device to clear the nonvolatile fault log by writing FFh to all byte locations. Once set, the device clears this bit when the action is completed. Host must set again for subsequent action. If an error occurs during this action, the device sets the CML bit in STATUS_WORD; no bits are set in STATUS_CML. While clearing the fault log, monitoring is stopped and commands should not be sent to the PMBus port.															
13:11	0	These bits always return a 0.															
10	NV_LOG_TO_CONFIG	This bit determines the source of the data written into the T0 location of each page when a nonvolatile fault log is written. 0 = Log the last regular collection interval ADC reading 1 = Read the latest ADC value before logging															
9	NV_LOG_OVERWRITE	0 = Do not overwrite the NV fault log 1 = Overwrite the NV fault log once it is full*															
8:7	NV_LOG_DEPTH[1:0]	These bits determine the depth of the NV fault log: <table border="1" style="margin-left: auto; margin-right: auto;"> <thead> <tr> <th style="text-align: left;">NV_LOG_DEPTH[1:0]</th> <th style="text-align: left;">INTERVAL</th> <th style="text-align: left;">NV FAULT LOG DEPTH</th> </tr> </thead> <tbody> <tr> <td>00</td> <td>5ms</td> <td>15ms</td> </tr> <tr> <td>01</td> <td>20ms</td> <td>60ms</td> </tr> <tr> <td>10</td> <td>80ms</td> <td>240ms</td> </tr> <tr> <td>11</td> <td>160ms</td> <td>480ms</td> </tr> </tbody> </table>	NV_LOG_DEPTH[1:0]	INTERVAL	NV FAULT LOG DEPTH	00	5ms	15ms	01	20ms	60ms	10	80ms	240ms	11	160ms	480ms
NV_LOG_DEPTH[1:0]	INTERVAL	NV FAULT LOG DEPTH															
00	5ms	15ms															
01	20ms	60ms															
10	80ms	240ms															
11	160ms	480ms															

**Table 28. MFR\_NV\_LOG\_CONFIG (D8h) (continued)**

BIT	NAME	MEANING
6	NV_LOG_FAULT0	0 = Do not write NV fault log when $\overline{\text{FAULT0}}$ pin is externally pulled low. 1 = Write NV fault log when $\overline{\text{FAULT0}}$ pin is externally pulled low and the $\overline{\text{FAULT0}}$ pin is enabled.
5	NV_LOG_FAULT1	0 = Do not write NV fault log when $\overline{\text{FAULT1}}$ pin is externally pulled low. 1 = Write NV fault log when $\overline{\text{FAULT1}}$ pin is externally pulled low and the $\overline{\text{FAULT1}}$ pin is enabled.
4	NV_LOG_FAULT2	0 = Do not write NV fault log when $\overline{\text{FAULT2}}$ pin is externally pulled low. 1 = Write NV fault log when $\overline{\text{FAULT2}}$ pin is externally pulled low and the $\overline{\text{FAULT2}}$ pin is enabled.
3	NV_LOG_FAULT3	0 = Do not write NV fault log when $\overline{\text{FAULT3}}$ pin is externally pulled low. 1 = Write NV fault log when $\overline{\text{FAULT3}}$ pin is externally pulled low and the $\overline{\text{FAULT3}}$ pin is enabled.
2:0	0	These bits always return a 0.

\*The device clears two fault logs at a time when overwrite is enabled.

### MFR\_FAULT\_RESPONSE (D9h)

The MFR\_FAULT\_RESPONSE command specifies the response to each fault or warning condition supported by the device. In response to a fault/warning, the device always reports the fault/warning in the appropriate status register and asserts the  $\overline{\text{ALERT}}$  output (if enabled in MFR\_MODE). A CML fault cannot cause any device action other than setting the status bit and asserting the  $\overline{\text{ALERT}}$  output. The MFR\_FAULT\_RESPONSE command is described in [Table 30](#) and [Figure 10](#).

For each fault type (overvoltage or overcurrent, undervoltage, sequencing error, and overtemperature), each channel can be independently configured to respond in the required manner with the RESPONSE bits in MFR\_FAULT\_RESPONSE ([Table 29](#)). If channels 0 to 15 are configured to latching for a particular fault, the channel turns off (either immediately or after the TOFF\_DELAY as configured or commanded) and also asserts one or more of the  $\overline{\text{FAULT}}$  pins if they are enabled with bits 16 to 19 in MFR\_FAULT\_RESPONSE. The channel remains off and the  $\overline{\text{FAULT}}$  outputs remain asserted until either the master power control is toggled using the OPERATION command or CONTROL0/1/2/3 pins as configured in the ON\_OFF\_CONFIG command or the device is reset or power cycled. When the device attempts to sequence the power supplies on, all enabled faults must be cleared before the channel is allowed to power-on or the  $\overline{\text{FAULT}}$  pins be deasserted.

If the channel is configured to retry for a particular fault, the channel turns off (either immediately or after the TOFF\_DELAY as configured or commanded) and also

asserts one or more the  $\overline{\text{FAULT}}$  pins if they are enabled with bits 16 to 19 in MFR\_FAULT\_RESPONSE. The channel remains off and the  $\overline{\text{FAULT}}$  outputs remain asserted for the time configured in MFR\_FAULT\_RETRY. After the time in MFR\_FAULT\_RETRY expires, the device attempts to sequence the power supplies back on as long as all the enabled faults in the channel are cleared. If all the enabled faults are cleared, the device deasserts all the  $\overline{\text{FAULT}}$  pins it asserted, and the power-up sequencing begins, as long as no other channels have asserted the  $\overline{\text{FAULT}}$  pins it has been configured to monitor with bits 24 to 27 in MFR\_FAULT\_RESPONSE.

Global channels must assert a  $\overline{\text{FAULT}}$  pin and respond to that  $\overline{\text{FAULT}}$  pin in order for the channel to shut down.

#### LOCAL vs. GLOBAL Channels

With the MFR\_FAULT\_RESPONSE command (bit 14), each power-supply channel can be tagged as either being LOCAL or GLOBAL. When bit 14 is cleared, the channel is configured as a LOCAL channel which means that a detected fault only affects this channel (or PAGE). With the RESPONSE bits in the MFR\_FAULT\_RESPONSE command, the device can be configured to respond differently to each possible fault. When bit 14 is set, the channel is configured as a GLOBAL channel which means that a detected fault on this channel can assert all enabled  $\overline{\text{FAULT}}$  outputs. Which  $\overline{\text{FAULT}}$  outputs are enabled is selected with bits 16 to 19. Only GLOBAL channels respond to  $\overline{\text{FAULT}}$  pins that are asserted. Which  $\overline{\text{FAULT}}$  pins the channel should respond to is assigned with bits 24 to 27. LOCAL channels do not respond to the fault pins.

**Table 29. Fault-Monitoring States**

FAULT	REQUIRED DEVICE CONFIGURATION FOR ACTIVE MONITORING	WHEN MONITORED
Overvoltage	<ul style="list-style-type: none"> <li>Voltage Monitoring Enabled (SELECT[5:0] = 10h or 20h in MFR_CHANNEL_CONFIG)</li> </ul>	Continuous monitoring
Undervoltage	<ul style="list-style-type: none"> <li>Voltage Monitoring Enabled (SELECT[5:0] = 10h or 20h in MFR_CHANNEL_CONFIG)</li> </ul>	Stop monitoring while the power supply is off; start monitoring when voltage exceeds the POWER_GOOD_ON level
Overcurrent	<ul style="list-style-type: none"> <li>Current Monitoring Enabled (SELECT[5:0] = 22h in MFR_CHANNEL_CONFIG)</li> </ul>	Continuous monitoring
Power-Up Time	<ul style="list-style-type: none"> <li>Sequencing Enabled (SELECT[5:0] = 10h in MFR_CHANNEL_CONFIG)</li> </ul>	Monitored only during power-on sequence
Overtemperature	<ul style="list-style-type: none"> <li>Temperature Sensor Enabled (ENABLE = 1 in MFR_TEMP_SENSOR_CONFIG)</li> </ul>	Continuous monitoring

**Note:** Device response to faults is determined by the configuration of MFR\_FAULT\_RESPONSE.

### GLOBAL Channels Respond to FAULT Assertion

Bits 24 to 27 in the MFR\_FAULT\_RESPONSE command are used to configure GLOBAL channels to respond or ignore one or more of the  $\overline{\text{FAULT}}$  pins when they are asserted. When one or more of the enabled  $\overline{\text{FAULT}}$  pins are asserted, the channel either deasserts the PSEN output immediately or after the TOFF\_DELAY according to the configuration of bit 0 in the ON\_OFF\_CONFIG command. The channel continues to deassert the PSEN output until all enabled  $\overline{\text{FAULT}}$  pins deassert. When all enabled  $\overline{\text{FAULT}}$  pins deassert, the channel sequences on as configured if no channel faults are present.

### Temperature Fault Response

A temperature fault is declared when any of the enabled temperature sensors detects a fault. A temperature fault acts globally and can affect all the power supplies. For all global supplies, the worse-case fault response of all global channels is applied. If this response is latching or retry, all  $\overline{\text{FAULT}}$  pins that are programmed to be asserted by any of the global channels are asserted. All local channels respond independently as programmed in that channel's MFR\_FAULT\_RESPONSE.

### Fault Detection Before Power-On Sequencing

Before any power-supply channel is enabled or  $\overline{\text{FAULT}}$  output is deasserted, the device checks for overvoltage, overcurrent, and overtemperature faults (but not for undervoltage) if the channel is configured for a fault response to either latch-off (RESPONSE[1:0] = 01) or retry (RESPONSE[1:0] = 10) in the MFR\_FAULT\_RESPONSE command. Undervoltage faults are detected when the power supply turns on and fails to reach the power-good level; the TON\_MAX\_FAULT\_LIMIT is exceeded and the device takes fault action as configured.

### Logging Faults into MFR\_NV\_FAULT\_LOG

If bit 15 of MFR\_FAULT\_RESPONSE is set, faults are logged into the on-board nonvolatile fault log for this channel unless the response for the associated fault is configured to take no action (RESPONSE[1:0] = 00). To keep from needlessly filling the fault log with excessive data, the following rules are applied when subsequent faults occur. When overvoltage faults occurs, subsequent overvoltage faults on this channel are not written to the fault log until either the CLEAR\_FAULTS command is issued or a device reset occurs. The same rule applies to overcurrent, undervoltage, overtemperature, and sequencing faults. See [Table 30](#) and [Figure 10](#).

**Table 30. MFR\_FAULT\_RESPONSE (D9h)**

BIT	NAME	MEANING
31:28	0	These bits always return a 0.
27	FAULT3_RESPONSE_ENABLE	0 = $\overline{\text{FAULT3}}$ response disabled 1 = $\overline{\text{FAULT3}}$ response enabled
26	FAULT2_RESPONSE_ENABLE	0 = $\overline{\text{FAULT2}}$ response disabled 1 = $\overline{\text{FAULT2}}$ response enabled
25	FAULT1_RESPONSE_ENABLE	0 = $\overline{\text{FAULT1}}$ response disabled 1 = $\overline{\text{FAULT1}}$ response enabled
24	FAULT0_RESPONSE_ENABLE	0 = $\overline{\text{FAULT0}}$ response disabled 1 = $\overline{\text{FAULT0}}$ response enabled
23:20	0	These bits always return a 0.
19	FAULT3_ASSERT_ENABLE	0 = $\overline{\text{FAULT3}}$ assertion disabled 1 = $\overline{\text{FAULT3}}$ assertion enabled
18	FAULT2_ASSERT_ENABLE	0 = $\overline{\text{FAULT2}}$ assertion disabled 1 = $\overline{\text{FAULT2}}$ assertion enabled
17	FAULT1_ASSERT_ENABLE	0 = $\overline{\text{FAULT1}}$ assertion disabled 1 = $\overline{\text{FAULT1}}$ assertion enabled
16	FAULT0_ASSERT_ENABLE	0 = $\overline{\text{FAULT0}}$ assertion disabled 1 = $\overline{\text{FAULT0}}$ assertion enabled
15	NV_LOG	0 = Do not log the fault into MFR_NV_FAULT_LOG 1 = Log the fault into MFR_NV_FAULT_LOG
14	GLOBAL	0 = LOCAL (affect only the selected page) 1 = GLOBAL (Note 1)
13:12	FILTER[1:0]	Continuous excursion time before a fault or warning is declared and action is taken (Note 2). 00 = Immediate 01 = 2ms 10 = 3ms 11 = 4ms
11	0	This bit always returns a 0.
10:8	ALARM_CONFIG[2:0]	See Table 31.
7:6	OT_FAULT_LIMIT_RESPONSE[1:0]	See Tables 32 and 33 (Note 3).
5:4	TON_MAX_FAULT_LIMIT_RESPONSE[1:0] (also applies to MFR_TON_SEQ_MAX)	See Tables 32 and 33 (Note 4).
3:2	VOUT_UV_FAULT_LIMIT_RESPONSE[1:0]	See Tables 32 and 33 (Note 4).
1:0	VOUT_OV_FAULT_LIMIT_RESPONSE[1:0] IOUT_OC_FAULT_LIMIT_RESPONSE[1:0]	See Tables 32 and 33 (Note 5).

**Note 1:** Channels configured to monitor current must be configured as GLOBAL.

**Note 2:** The FILTER selection does not apply to temperature or sequencing faults.

**Note 3:** All enabled temperature sensor faults are logically ORed together.

**Note 4:** If the channel is configured to measure current, these bits are ignored.

**Note 5:** Depends on whether the channel is configured to monitor voltage or current.

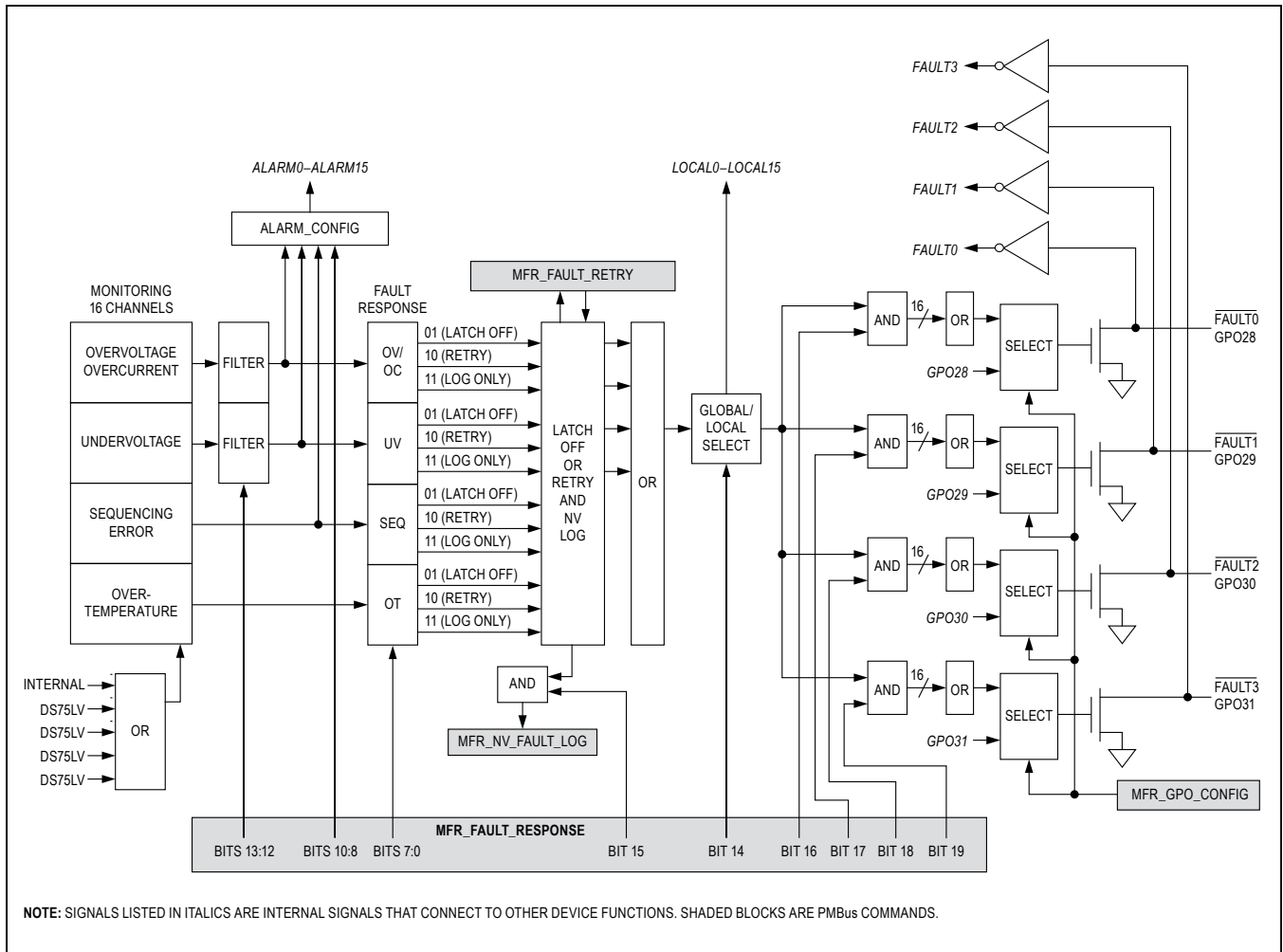

Figure 10. MFR\_FAULT\_RESPONSE Operation

Table 31. ALARM\_CONFIG Codes

ALARM_CONFIG[2:0]	ALARM CONDITION	ALARM CRITERIA
000	None	—
001	Sequencing fault	Fault only
010	Undervoltage only	Fault only
011	Undervoltage only	Fault or warning
100	Overvoltage/overcurrent only	Fault only
101	Overvoltage/overcurrent only	Fault or warning
110	Undervoltage or overvoltage/overcurrent	Fault only
111	Undervoltage or overvoltage/overcurrent	Fault or warning

**Alarm Output Functionality**

Any of the GPO pins can be configured to output the alarm signals. See the MFR\_DAC\_CONFIG, MFR\_GPO\_CONFIG and MFR\_PSEN\_CONFIG commands for details. When an undervoltage or overvoltage/overcurrent

alarm is occurring, the output remains asserted as long as the alarm continues. When a sequencing fault occurs, the alarm pin remain asserted until either a CLEAR\_FAULTS command is received or master power control-off input is received with either the OPERATION command or the CONTROL pins.

**Table 32. MFR\_FAULT\_RESPONSE Codes for GLOBAL Channels**

RESPONSE[1:0]	FAULT RESPONSE
11	<ul style="list-style-type: none"> <li>• Sets the corresponding fault bit in the appropriate status register (Note 1).</li> <li>• Logs fault into MFR_NV_FAULT_LOG if NV_LOG = 1.</li> <li>• Continues operation.</li> </ul>
10 (Retry)	<ul style="list-style-type: none"> <li>• Asserts all enabled <math>\overline{\text{FAULT}}</math> outputs.</li> <li>• Sets the corresponding fault bit in the appropriate status register (Note 1).</li> <li>• Logs fault into MFR_NV_FAULT_LOG if NV_LOG = 1.</li> <li>• Waits for the time configured in MFR_FAULT_RETRY and then deasserts the <math>\overline{\text{FAULT}}</math> outputs that were asserted if fault-free (Note 2).</li> </ul>
01 (Latchoff)	<ul style="list-style-type: none"> <li>• Asserts all enabled <math>\overline{\text{FAULT}}</math> outputs.</li> <li>• Sets the corresponding fault bit in the appropriate status register (Note 1).</li> <li>• Logs fault into MFR_NV_FAULT_LOG if NV_LOG = 1.</li> </ul>
00	<ul style="list-style-type: none"> <li>• Sets the corresponding fault bit in the appropriate status register (Note 1).</li> <li>• Continues operation without any action.</li> </ul>

**Note 1:**  $\overline{\text{ALERT}}$  is asserted if enabled when a new status bit is set. A status bit is latched when a particular fault occurs that causes a fault response.

**Note 2:** Fault-free does not include undervoltage.

**Table 33. MFR\_FAULT\_RESPONSE Codes for LOCAL Channels**

RESPONSE[1:0]	FAULT RESPONSE
11	<ul style="list-style-type: none"> <li>• Sets the corresponding fault bit in the appropriate status register (Note 1).</li> <li>• Logs fault into MFR_NV_FAULT_LOG if NV_LOG = 1.</li> <li>• Continues operation.</li> </ul>
10 (Retry)	<ul style="list-style-type: none"> <li>• Shuts down the power supply by deasserting the PSEN output.</li> <li>• Sets the corresponding fault bit in the appropriate status register (Note 1).</li> <li>• Logs fault into MFR_NV_FAULT_LOG if NV_LOG = 1.</li> <li>• Waits for the time configured in MFR_FAULT_RETRY and restarts the supply if fault-free (Note 2).</li> </ul>
01 (Latchoff)	<ul style="list-style-type: none"> <li>• Latches off the power supply by deasserting the PSEN output.</li> <li>• Sets the corresponding fault bit in the appropriate status register (Note 1).</li> <li>• Logs fault into MFR_NV_FAULT_LOG if NV_LOG = 1.</li> </ul>
00	<ul style="list-style-type: none"> <li>• Sets the corresponding fault bit in the appropriate status register (Note 1).</li> <li>• Continues operation without any action.</li> </ul>

**Note 1:**  $\overline{\text{ALERT}}$  is asserted if enabled when a new status bit is set. A status bit is latched when a particular fault occurs that causes a fault response.

**Note 2:** Fault-free does not include undervoltage.

**MFR\_FAULT\_RETRY (DAh)**

The MFR\_FAULT\_RETRY command sets the delay time between a fault occurring, which results in a power supply being shut down for retry and the power supply restarting. This command value is used for all fault responses that require delay retry. The retry timer starts when the fault occurs. If the faulty channel has been configured to assert one or more FAULT pins, the FAULT pins are asserted until the retry timer expires and then they are allowed to deassert as long as no enabled faults are still present and no other channel that shares the same FAULT pins have not also asserted. MFR\_FAULT\_RETRY should be configured with a value larger than the largest system TOFF\_DELAY. The 2 data bytes are in DIRECT format.

**MFR\_NV\_FAULT\_LOG (DCh)**

Each time the MFR\_NV\_FAULT\_LOG command is executed, the device returns a block of 255 bytes containing one of the 15 nonvolatile fault logs. The MFR\_NV\_FAULT\_LOG command must be executed 15 times to dump the complete nonvolatile fault log. If the returned fault log is all FF's (except bytes 0 and 1), this indicates that this fault log has not been written by the device. As the device is operating, it is reading the latest operating conditions for voltage, current and temperature and it is updating the status registers. All this information is stored in on-board RAM. When a fault is detected (if so enabled

in MFR\_FAULT\_RESPONSE), the device automatically logs this information to one of the 15 nonvolatile fault logs. After 15 faults have been written, bit 0 of STATUS\_CML is set and the device can be configured (with the NV\_LOG\_OVERWRITE bit in MFR\_NV\_LOG\_CONFIG) to either stop writing additional fault logs or to write over the oldest data. The host can clear the fault log by setting the CLEAR\_NV\_FAULT\_LOG bit in MFR\_NV\_LOG\_CONFIG. If a power supply is not enabled to measure voltage, current or if a temperature sensor is disabled, the associated fault log position returns 0000h (see Figure 11).

There is a FAULT\_LOG\_COUNT (16-bit counter) at the beginning of each fault log that indicates which fault log is the latest. This counter rolls over should more than 65535 faults be logged. This counter is not cleared when the CLEAR\_NV\_FAULT\_LOG bit in MFR\_NV\_LOG\_CONFIG is toggled. The 255 bytes returned by the MFR\_NV\_FAULT\_LOG command are described in Table 34.

If an error occurs while the device is attempting to write or clear the MFR\_NV\_FAULT\_LOG, the device sets the CML bit in STATUS\_WORD; no bits are set in STATUS\_CML. ALERT is asserted (if enabled in MFR\_MODE).

**USER NOTE: V<sub>DD</sub> must be above 2.9V for the device to clear or log data into MFR\_NV\_FAULT\_LOG.**

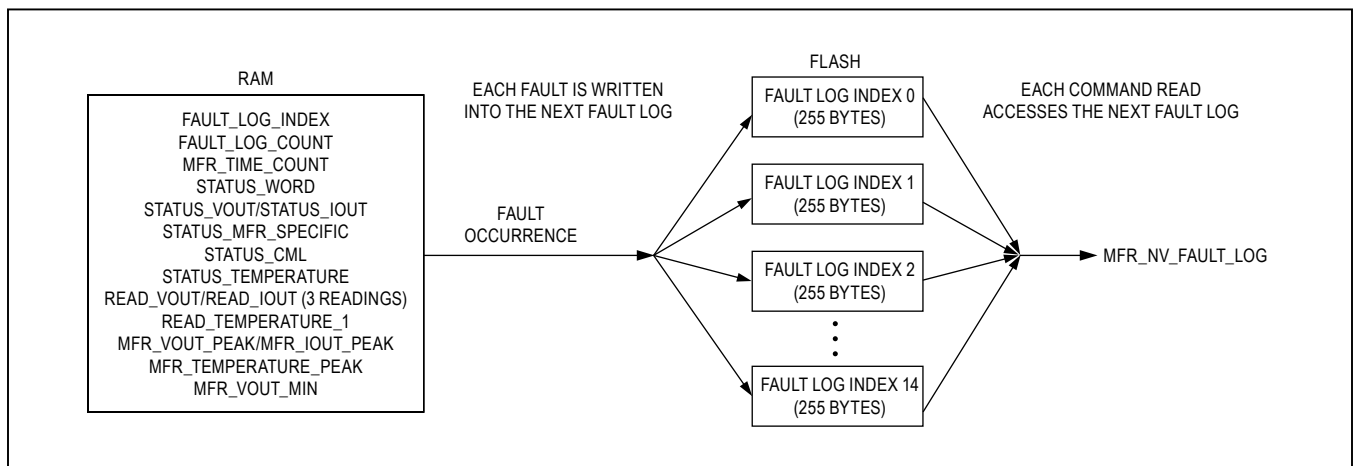

Figure 11. MFR\_NV\_FAULT\_LOG

Table 34. MFR\_NV\_FAULT\_LOG (DCh)

BYTE	PARAMETER	BYTE	PARAMETER
0	00h/FAULT_LOG_INDEX	128	READ_VOUT/READ_IOUT T1 PAGE 11
2	FAULT_LOG_COUNT	130	READ_VOUT/READ_IOUT T2 PAGE 11
4	MFR_TIME_COUNT (LSW)	132	READ_VOUT/READ_IOUT T0 PAGE 12
6	MFR_TIME_COUNT (MSW)	134	READ_VOUT/READ_IOUT T1 PAGE 12
8	0000h	136	READ_VOUT/READ_IOUT T2 PAGE 12
10	STATUS_CML/00h	138	READ_VOUT/READ_IOUT T0 PAGE 13
12	STATUS_WORD	140	READ_VOUT/READ_IOUT T1 PAGE 13
14	STATUS_VOUT/STATUS_IOUT PAGES 0/1	142	READ_VOUT/READ_IOUT T2 PAGE 13
16	STATUS_VOUT/STATUS_IOUT PAGES 2/3	144	READ_VOUT/READ_IOUT T0 PAGE 14
18	STATUS_VOUT/STATUS_IOUT PAGES 4/5	146	READ_VOUT/READ_IOUT T1 PAGE 14
20	STATUS_VOUT/STATUS_IOUT PAGES 6/7	148	READ_VOUT/READ_IOUT T2 PAGE 14
22	STATUS_VOUT/STATUS_IOUT PAGES 8/9	150	READ_VOUT/READ_IOUT T0 PAGE 15
24	STATUS_VOUT/STATUS_IOUT PAGES 10/11	152	READ_VOUT/READ_IOUT T1 PAGE 15
26	STATUS_VOUT/STATUS_IOUT PAGES 12/13	154	READ_VOUT/READ_IOUT T2 PAGE 15
28	STATUS_VOUT/STATUS_IOUT PAGES 14/15	156	0000h
30	STATUS_MFR_SPECIFIC PAGES 0/1	158	0000h
32	STATUS_MFR_SPECIFIC PAGES 2/3	160	0000h
34	STATUS_MFR_SPECIFIC PAGES 4/5	162	0000h
36	STATUS_MFR_SPECIFIC PAGES 6/7	164	MFR_VOUT_PEAK/MFR_IOUT_PEAK PAGE 0
38	STATUS_MFR_SPECIFIC PAGES 8/9	166	MFR_VOUT_PEAK/MFR_IOUT_PEAK PAGE 1
40	STATUS_MFR_SPECIFIC PAGES 10/11	168	MFR_VOUT_PEAK/MFR_IOUT_PEAK PAGE 2
42	STATUS_MFR_SPECIFIC PAGES 12/13	170	MFR_VOUT_PEAK/MFR_IOUT_PEAK PAGE 3
44	STATUS_MFR_SPECIFIC PAGES 14/15	172	MFR_VOUT_PEAK/MFR_IOUT_PEAK PAGE 4
46	STATUS_MFR_SPECIFIC PAGE 255/00h	174	MFR_VOUT_PEAK/MFR_IOUT_PEAK PAGE 5
48	STATUS_TEMPERATURE PAGES 16/17	176	MFR_VOUT_PEAK/MFR_IOUT_PEAK PAGE 6
50	STATUS_TEMPERATURE PAGES 18/19	178	MFR_VOUT_PEAK/MFR_IOUT_PEAK PAGE 7
52	STATUS_TEMPERATURE PAGE 20/00h	180	MFR_VOUT_PEAK/MFR_IOUT_PEAK PAGE 8
54	CURRENT_CHANNELS (Note 1)	182	MFR_VOUT_PEAK/MFR_IOUT_PEAK PAGE 9
56	0000h	184	MFR_VOUT_PEAK/MFR_IOUT_PEAK PAGE 10
58	0000h	186	MFR_VOUT_PEAK/MFR_IOUT_PEAK PAGE 11
60	READ_VOUT/READ_IOUT T0 PAGE 0 (Notes 2, 3)	188	MFR_VOUT_PEAK/MFR_IOUT_PEAK PAGE 12
62	READ_VOUT/READ_IOUT T1 PAGE 0	190	MFR_VOUT_PEAK/MFR_IOUT_PEAK PAGE 13
64	READ_VOUT/READ_IOUT T2 PAGE 0	192	MFR_VOUT_PEAK/MFR_IOUT_PEAK PAGE 14
66	READ_VOUT/READ_IOUT T0 PAGE 1	194	MFR_VOUT_PEAK/MFR_IOUT_PEAK PAGE 15
68	READ_VOUT/READ_IOUT T1 PAGE 1	196	MFR_VOUT_MIN PAGE 0
70	READ_VOUT/READ_IOUT T2 PAGE 1	198	MFR_VOUT_MIN PAGE 1
72	READ_VOUT/READ_IOUT T0 PAGE 2	200	MFR_VOUT_MIN PAGE 2
74	READ_VOUT/READ_IOUT T1 PAGE 2	202	MFR_VOUT_MIN PAGE 3
76	READ_VOUT/READ_IOUT T2 PAGE 2	204	MFR_VOUT_MIN PAGE 4
78	READ_VOUT/READ_IOUT T0 PAGE 3	206	MFR_VOUT_MIN PAGE 5
80	READ_VOUT/READ_IOUT T1 PAGE 3	208	MFR_VOUT_MIN PAGE 6
82	READ_VOUT/READ_IOUT T2 PAGE 3	210	MFR_VOUT_MIN PAGE 7
84	READ_VOUT/READ_IOUT T0 PAGE 4	212	MFR_VOUT_MIN PAGE 8

**Table 34. MFR\_NV\_FAULT\_LOG (DCh) (continued)**

BYTE	PARAMETER	BYTE	PARAMETER
86	READ_VOUT/READ_IOUT T1 PAGE 4	214	MFR_VOUT_MIN PAGE 9
88	READ_VOUT/READ_IOUT T2 PAGE 4	216	MFR_VOUT_MIN PAGE 10
90	READ_VOUT/READ_IOUT T0 PAGE 5	218	MFR_VOUT_MIN PAGE 11
92	READ_VOUT/READ_IOUT T1 PAGE 5	220	MFR_VOUT_MIN PAGE 12
94	READ_VOUT/READ_IOUT T2 PAGE 5	222	MFR_VOUT_MIN PAGE 13
96	READ_VOUT/READ_IOUT T0 PAGE 6	224	MFR_VOUT_MIN PAGE 14
98	READ_VOUT/READ_IOUT T1 PAGE 6	226	MFR_VOUT_MIN PAGE 15
100	READ_VOUT/READ_IOUT T2 PAGE 6	228	0000h
102	READ_VOUT/READ_IOUT T0 PAGE 7	230	0000h
104	READ_VOUT/READ_IOUT T1 PAGE 7	232	READ_TEMPERATURE_1 PAGE 16
106	READ_VOUT/READ_IOUT T2 PAGE 7	234	READ_TEMPERATURE_1 PAGE 17
108	READ_VOUT/READ_IOUT T0 PAGE 8	236	READ_TEMPERATURE_1 PAGE 18
110	READ_VOUT/READ_IOUT T1 PAGE 8	238	READ_TEMPERATURE_1 PAGE 19
112	READ_VOUT/READ_IOUT T2 PAGE 8	240	READ_TEMPERATURE_1 PAGE 20
114	READ_VOUT/READ_IOUT T0 PAGE 9	242	MFR_TEMPERATURE_PEAK PAGE 16
116	READ_VOUT/READ_IOUT T1 PAGE 9	244	MFR_TEMPERATURE_PEAK PAGE 17
118	READ_VOUT/READ_IOUT T2 PAGE 9	246	MFR_TEMPERATURE_PEAK PAGE 18
120	READ_VOUT/READ_IOUT T0 PAGE 10	248	MFR_TEMPERATURE_PEAK PAGE 19
122	READ_VOUT/READ_IOUT T1 PAGE 10	250	MFR_TEMPERATURE_PEAK PAGE 20
124	READ_VOUT/READ_IOUT T2 PAGE 10	252	0000h
126	READ_VOUT/READ_IOUT T0 PAGE 11	254	LOG_VALID (Note 4)

**Note 1:** CURRENT\_CHANNELS is a bitmask (0 = voltage/1 = current) indicating which channels are enabled for current measurement.

**Note 2:** For READ\_VOUT, READ\_IOUT, T2 is the oldest reading and T0 is the newest reading.

**Note 3:** STATUS\_V(I)OUT and READ\_V(I)OUT depend on whether the channel is configured to monitor voltage or current.

**Note 4:** LOG\_VALID is set to DDh if the fault log contains valid data.

### MFR\_TIME\_COUNT (DDh)

The MFR\_TIME\_COUNT command returns the current value of a real time counter which increments every 5ms, 20ms, 80ms, or 160ms depending on the configuration of the NV\_LOG\_DEPTH bits in MFR\_NV\_LOG\_CONFIG. This counter is useful in determining the time between multiple faults. The counter is a 32-bit value that rolls over. The count is reset to zero upon device power cycle or  $\overline{\text{RST}}$  action or a soft reset. MFR\_TIME\_COUNT can be preset to any value and starts counting up from the preset value.

### MFR\_CHANNEL\_CONFIG (E4h)

The MFR\_CHANNEL\_CONFIG command is used to configure the monitoring channels (PAGES 0 to 15). This command should not be changed while the power supplies are operating. The MFR\_CHANNEL\_CONFIG command is described in [Table 35](#) and [Figure 12](#).

Each RS/GPI pin can be independently configured using the SELECT[5:0] bits to one of the following:

- Monitor voltage; use the monitored voltage for sequencing (SELECT[5:0] = 10h)
- Monitor voltage; do not use for sequencing (SELECT[5:0] = 20h)
- Monitor current (SELECT[5:0] = 22h)
- Read voltage only; do not monitor for voltage faults or warnings (SELECT[5:0] = 21h)
- Read current only; do not monitor for current faults or warnings (SELECT[5:0] = 23h)
- General-purpose input (GPI); active low (SELECT[5:0] = 30h)
- General-purpose input (GPI); active high (SELECT[5:0] = 34h)
- Input is disabled (SELECT[5:0] = 00h)

If the monitoring channel is configured to monitor voltage for sequencing (SELECT[5:0] = 10h), then the associated PSEN output channel must also be configured for controlling power supplies by setting the SELECT bits in MFR\_PSEN\_CONFIG to 000. See the MFR\_PSEN\_CONFIG command description for more details.

When the RS/GPI pins are configured as general-purpose inputs (GPI), the READ\_VOUT command reports 0000h when the pin is inactive and 0001h when the pin is active.

Also when the RS/GPI pins are configured to monitor voltage or act as GPI (SELECT[5:0] = 10h or 20h or 30h or 34h), each channel can be independently configured to generate a signature signal at the SEQ output to facilitate event-based sequencing in multiple device systems by indicating that this power supply has reached its POWER\_GOOD\_ON level and other channels can now proceed with their power-up.

**Table 35. MFR\_CHANNEL\_CONFIG (E4h)**

BIT	NAME	MEANING																																
15:12	0	These bits always return a 0.																																
11:8	SEQ_GENERATE	<p>These bits determine which <math>\overline{\text{SEQ}}</math> signature the channel should generate after crossing the POWER_GOOD_ON level:</p> <table border="0"> <tr> <td>0000</td> <td>Disabled</td> <td>1000</td> <td>Signature 8</td> </tr> <tr> <td>0001</td> <td>Signature 1</td> <td>1001</td> <td>Signature 9</td> </tr> <tr> <td>0010</td> <td>Signature 2</td> <td>1010</td> <td>Signature 10</td> </tr> <tr> <td>0011</td> <td>Signature 3</td> <td>1011</td> <td>Signature 11</td> </tr> <tr> <td>0100</td> <td>Signature 4</td> <td>1100</td> <td>Signature 12</td> </tr> <tr> <td>0101</td> <td>Signature 5</td> <td>1101</td> <td>Signature 13</td> </tr> <tr> <td>0110</td> <td>Signature 6</td> <td>1110</td> <td>Signature 14</td> </tr> <tr> <td>0111</td> <td>Signature 7</td> <td>1111</td> <td>Signature 15</td> </tr> </table>	0000	Disabled	1000	Signature 8	0001	Signature 1	1001	Signature 9	0010	Signature 2	1010	Signature 10	0011	Signature 3	1011	Signature 11	0100	Signature 4	1100	Signature 12	0101	Signature 5	1101	Signature 13	0110	Signature 6	1110	Signature 14	0111	Signature 7	1111	Signature 15
0000	Disabled	1000	Signature 8																															
0001	Signature 1	1001	Signature 9																															
0010	Signature 2	1010	Signature 10																															
0011	Signature 3	1011	Signature 11																															
0100	Signature 4	1100	Signature 12																															
0101	Signature 5	1101	Signature 13																															
0110	Signature 6	1110	Signature 14																															
0111	Signature 7	1111	Signature 15																															
7:6	0	These bits always return a 0.																																
5:0	SELECT[5:0]	<p>These bits select the function of the RS/GPI pins:</p> <table border="0"> <thead> <tr> <th><u>SELECT[5:0]</u></th> <th><u>SELECTED CHANNEL FUNCTION</u></th> </tr> </thead> <tbody> <tr> <td>010000 (10h)</td> <td>Sequencing + voltage monitoring*</td> </tr> <tr> <td>100000 (20h)</td> <td>Voltage monitoring (no sequencing)</td> </tr> <tr> <td>100010 (22h)</td> <td>Current monitoring</td> </tr> <tr> <td>100001 (21h)</td> <td>Voltage read only</td> </tr> <tr> <td>100011 (23h)</td> <td>Current read only</td> </tr> <tr> <td>110000 (30h)</td> <td>General-purpose input active low</td> </tr> <tr> <td>110100 (34h)</td> <td>General-purpose input active high</td> </tr> <tr> <td>000000 (00h)</td> <td>Disabled</td> </tr> </tbody> </table>	<u>SELECT[5:0]</u>	<u>SELECTED CHANNEL FUNCTION</u>	010000 (10h)	Sequencing + voltage monitoring*	100000 (20h)	Voltage monitoring (no sequencing)	100010 (22h)	Current monitoring	100001 (21h)	Voltage read only	100011 (23h)	Current read only	110000 (30h)	General-purpose input active low	110100 (34h)	General-purpose input active high	000000 (00h)	Disabled														
<u>SELECT[5:0]</u>	<u>SELECTED CHANNEL FUNCTION</u>																																	
010000 (10h)	Sequencing + voltage monitoring*																																	
100000 (20h)	Voltage monitoring (no sequencing)																																	
100010 (22h)	Current monitoring																																	
100001 (21h)	Voltage read only																																	
100011 (23h)	Current read only																																	
110000 (30h)	General-purpose input active low																																	
110100 (34h)	General-purpose input active high																																	
000000 (00h)	Disabled																																	

\*For proper sequencing, the SELECT bits in MFR\_PSEN\_CONFIG must set to 000.

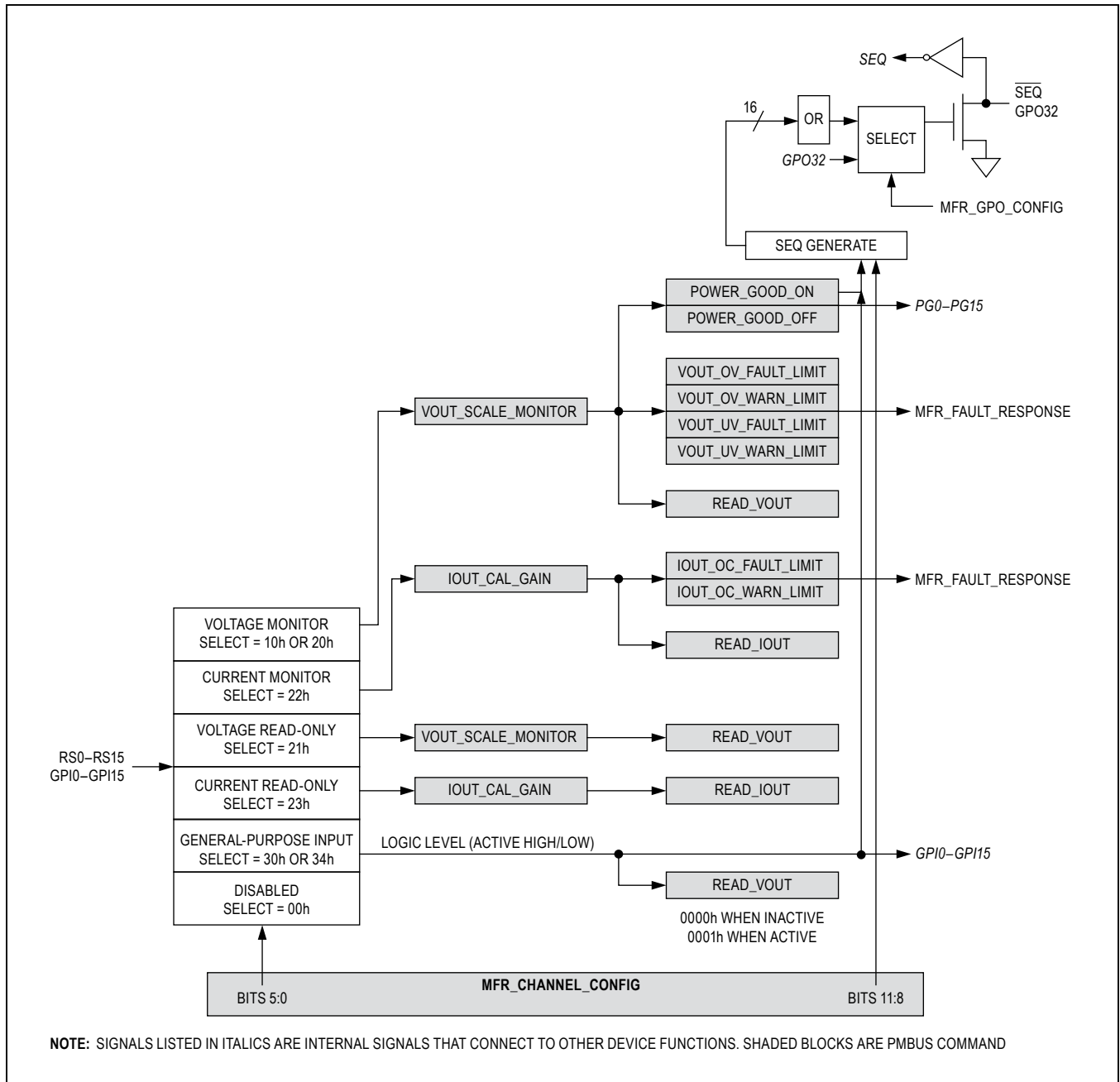

Figure 12. MFR\_CHANNEL\_CONFIG Command

**MFR\_TON\_SEQ\_MAX (E6h)**

The MFR\_TON\_SEQ\_MAX command sets an upper limit, in milliseconds, from a sequencing group (either SEQUENCE0 or SEQUENCE1 or SEQUENCE2 or SEQUENCE3 as chosen by the SEQ\_SELECT bits in the MFR\_SEQ\_CONFIG command) initiating the power-up sequence until the channel expects to begin its power-up based on an event which could be either a logic combination of power-good (PG) and GPI signals or a match on the  $\overline{\text{SEQ}}$  pin as configured with the SELECT bits in MFR\_SEQ\_CONFIG. The 2 data bytes are in DIRECT format. If this value is zero, then the limit is disabled. In response to the MFR\_TON\_SEQ\_MAX being exceeded, the device does the following:

- 1) Sets the VOUT bit in STATUS\_WORD.
- 2) Sets the TON\_MAX\_FAULT bit in STATUS\_VOUT.
- 3) Responds as specified in the MFR\_FAULT\_RESPONSE.
- 4) Notifies the host using  $\overline{\text{ALERT}}$  assertion (if enabled in MFR\_MODE).

**MFR\_SEQ\_CONFIG (E8h)**

The MFR\_SEQ\_CONFIG command is used to configure the sequencing channels (PAGES 0 to 15). This command should not be changed while the power supplies are operating. The MFR\_SEQ\_CONFIG command is described in [Table 36](#) and [Figure 2](#).

Each channel can be independently configured to initiate power-on sequencing using the SELECT[1:0] bits to one of the following conditions:

- Wait for either SEQUENCE0 or SEQUENCE1 or SEQUENCE2 or SEQUENCE3 from ON\_OFF\_CONFIG decode (SELECT[1:0] = 00).
- Wait for all enabled channel power-good (PG) or GPI are asserted (SELECT[1:0] = 01).
- Wait for a match on the  $\overline{\text{SEQ}}$  pin (SELECT[2:0] = 10).

If SELECT[1:0] = 00, the channel waits for either the SEQUENCE0 or SEQUENCE1 or SEQUENCE2 or SEQUENCE3 signal to assert before powering on. Which sequence signal to use is selected with the SEQ\_SELECT bits. The SEQUENCE (0 to 3) signals are generated by decoding the OPERATION command and CONTROL0/1/2/3 pins using the ON\_OFF\_CONFIG command. See the ON\_OFF\_CONFIG command description for details. This selection would be used if the channel is being controlled by time-based sequencing.

If SELECT[1:0] = 01, then sequencing for this channel is initiated when some combination of power-goods (PG)

and general purpose inputs (GPI) are asserted. Which channels should be used in this combination are selected using the PG\_GPI\_SELECT bits (bit 16 to 31). If the PG\_GPI\_SELECT bit is cleared, then the associated channel is not used in the logical combination to assert the GPO output. If the PG\_GPI\_SELECT bit is set, then the power-good or GPI from this channel is used in the logical combination to initiate the power-on sequencing. This selection would be used if the channel is being controlled by event-based sequencing.

If SELECT[1:0] = 10, then sequencing is initiated when the channel matches the selected signature on the SEQ pin. Use the the SEQ\_MATCH bits to select which signature to match. The  $\overline{\text{SEQ}}$  signal is used to facilitate event-based sequencing in multiple device systems. This selection would be used if the channel is being controlled by event-based sequencing.

**MFR\_DAC\_CONFIG (E9h)**

The MFR\_DAC\_CONFIG command is used to configure the individual DACx/GPOy (x = 0 to 11 / y = 16 to 27) outputs. This command should not be changed while the power supplies are operating. The MFR\_DAC\_CONFIG command is described in [Table 37](#) and [Figure 13](#).

Each DAC/GPO pin can be independently configured using the SELECT[2:0] bits to one of the following:

- DAC margining operation (SELECT[2:0] = 000)
- Force pin assertion (SELECT[2:0] = 001)
- Force pin deassertion (SELECT[2:0] = 010)
- Assert when all enabled channel power-good (PG) or GPI are asserted (SELECT[2:0] = 011)
- Assert when any enabled alarm goes active (SELECT[2:0] = 100)

Also each DAC/GPO pin can be independently configured to be either active high or active low and either push-pull or open drain using the HI\_LO and PP\_OD bits, respectively.

If SELECT[2:0] = 011, the DAC/GPO output is configured to assert when some combination of power-goods (PG) and general purpose inputs (GPI) from each channel are asserted. Which channels should be used in this combination are selected using the PG\_GPI\_SELECT bits (bit 16 to 31). If the PG\_GPI\_SELECT bit is cleared, then the associated channel is not used in the logical combination to assert the GPO output. If the PG\_GPI\_SELECT bit is set, then the power-good or GPI from this channel is used in the logical combination to assert the GPO output. This function is useful in creating system power-good signals.

**Table 36. MFR\_SEQ\_CONFIG (E8h)**

BIT	NAME	MEANING																																
31:16	PG_GPI_SELECT	These bits are only used if SELECT[1:0] = 01; each bit corresponds to one channel (device channel N + 16 = bit number). When these bits are cleared, the power-good (PG) or GPI from channel N is not used in the logical AND to initiate power-on sequencing. When these bits are set, the PG or GPI is used.																																
15:12	0	These bits always return a 0.																																
11:8	SEQ_MATCH	These bits determine which $\overline{\text{SEQ}}$ signature the channel must match before initiating power on sequencing: <table border="0" style="margin-left: 20px;"> <tr> <td>0000</td> <td>Disabled</td> <td>1000</td> <td>Signature 8</td> </tr> <tr> <td>0001</td> <td>Signature 1</td> <td>1001</td> <td>Signature 9</td> </tr> <tr> <td>0010</td> <td>Signature 2</td> <td>1010</td> <td>Signature 10</td> </tr> <tr> <td>0011</td> <td>Signature 3</td> <td>1011</td> <td>Signature 11</td> </tr> <tr> <td>0100</td> <td>Signature 4</td> <td>1100</td> <td>Signature 12</td> </tr> <tr> <td>0101</td> <td>Signature 5</td> <td>1101</td> <td>Signature 13</td> </tr> <tr> <td>0110</td> <td>Signature 6</td> <td>1110</td> <td>Signature 14</td> </tr> <tr> <td>0111</td> <td>Signature 7</td> <td>1111</td> <td>Signature 15</td> </tr> </table>	0000	Disabled	1000	Signature 8	0001	Signature 1	1001	Signature 9	0010	Signature 2	1010	Signature 10	0011	Signature 3	1011	Signature 11	0100	Signature 4	1100	Signature 12	0101	Signature 5	1101	Signature 13	0110	Signature 6	1110	Signature 14	0111	Signature 7	1111	Signature 15
0000	Disabled	1000	Signature 8																															
0001	Signature 1	1001	Signature 9																															
0010	Signature 2	1010	Signature 10																															
0011	Signature 3	1011	Signature 11																															
0100	Signature 4	1100	Signature 12																															
0101	Signature 5	1101	Signature 13																															
0110	Signature 6	1110	Signature 14																															
0111	Signature 7	1111	Signature 15																															
7:6	0	These bits always return a 0.																																
5:4	SELECT[1:0]	These bits determine the signal that initiates power-on sequencing: <table border="0" style="margin-left: 20px;"> <thead> <tr> <th style="text-align: left;"><u>SELECT[1:0]</u></th> <th style="text-align: left;"><u>SELECTED POWER-ON SEQUENCING CONTROL SIGNAL</u></th> <th style="text-align: left;"><u>SEQUENCING TYPE</u></th> </tr> </thead> <tbody> <tr> <td>00</td> <td>SEQUENCE<sub>n</sub> (n = 1, 2, 3) (use bits 1:0)</td> <td>Time-based</td> </tr> <tr> <td>01</td> <td>PG/GPI logic combination (use bits 31:16)</td> <td>Event-based</td> </tr> <tr> <td>10</td> <td><math>\overline{\text{SEQ}}</math> Match (use bits 11:8)</td> <td>Event-based</td> </tr> <tr> <td>11</td> <td>Reserved</td> <td>—</td> </tr> </tbody> </table>	<u>SELECT[1:0]</u>	<u>SELECTED POWER-ON SEQUENCING CONTROL SIGNAL</u>	<u>SEQUENCING TYPE</u>	00	SEQUENCE <sub>n</sub> (n = 1, 2, 3) (use bits 1:0)	Time-based	01	PG/GPI logic combination (use bits 31:16)	Event-based	10	$\overline{\text{SEQ}}$ Match (use bits 11:8)	Event-based	11	Reserved	—																	
<u>SELECT[1:0]</u>	<u>SELECTED POWER-ON SEQUENCING CONTROL SIGNAL</u>	<u>SEQUENCING TYPE</u>																																
00	SEQUENCE <sub>n</sub> (n = 1, 2, 3) (use bits 1:0)	Time-based																																
01	PG/GPI logic combination (use bits 31:16)	Event-based																																
10	$\overline{\text{SEQ}}$ Match (use bits 11:8)	Event-based																																
11	Reserved	—																																
3:2	0	These bits always return a 0.																																
1:0	SEQ_SELECT[1:0]	00 = SEQUENCE0 01 = SEQUENCE1 10 = SEQUENCE2 11 = SEQUENCE3																																

If SELECT[2:0] = 100, the DAC/GPO output is configured to assert when any of the enabled channel alarms goes active. The channel alarms are enabled with the ALARM\_SELECT bits (bit 16 to 31). If the ALARM\_SELECT bit is cleared, then the alarm from this channel is blocked. If the ALARM\_SELECT bit is set, then the alarm from this

channel is routed to an OR function such that any enabled alarm asserts the GPO output. The alarm function is chosen with the ALARM\_CONFIG bits in the MFR\_FAULT\_RESPONSE command. This function is useful in system debug or for enabling system status LEDs.

**Table 37. MFR\_DAC\_CONFIG (E9h)**

BIT	NAME	MEANING																																				
31:16	PG_GPI_SELECT ALARM_SELECT	<p>These bits are only used if SELECT[2:0] = 011 or 100; each bit corresponds to one channel (device channel N + 16 = bit number):</p> <table border="0"> <thead> <tr> <th>SELECT[2:0]</th> <th>BIT FUNCTION</th> </tr> </thead> <tbody> <tr> <td>011</td> <td>When this bit is cleared, the power-good (PG) or GPI from channel N is not used in the logical AND to assert the GPO output. When this bit is set, the PG or GPI is used.</td> </tr> <tr> <td>100</td> <td>When this bit is cleared, the alarm from channel N is blocked from the logical OR to assert the GPO output. When this bit is set, the alarm signal is routed to the logical OR.</td> </tr> </tbody> </table>	SELECT[2:0]	BIT FUNCTION	011	When this bit is cleared, the power-good (PG) or GPI from channel N is not used in the logical AND to assert the GPO output. When this bit is set, the PG or GPI is used.	100	When this bit is cleared, the alarm from channel N is blocked from the logical OR to assert the GPO output. When this bit is set, the alarm signal is routed to the logical OR.																														
SELECT[2:0]	BIT FUNCTION																																					
011	When this bit is cleared, the power-good (PG) or GPI from channel N is not used in the logical AND to assert the GPO output. When this bit is set, the PG or GPI is used.																																					
100	When this bit is cleared, the alarm from channel N is blocked from the logical OR to assert the GPO output. When this bit is set, the alarm signal is routed to the logical OR.																																					
15:12	OFF_DELAY	<p>These bits determine the delay time to pin deassertion (Notes 1 and 2):</p> <table border="0"> <thead> <tr> <th>OFF_DELAY[3:0]</th> <th>DELAY TIME</th> <th>OFF_DELAY[3:0]</th> <th>DELAY TIME</th> </tr> </thead> <tbody> <tr><td>0000</td><td>0ms</td><td>1000</td><td>200ms</td></tr> <tr><td>0001</td><td>5ms</td><td>1001</td><td>400ms</td></tr> <tr><td>0010</td><td>10ms</td><td>1010</td><td>600ms</td></tr> <tr><td>0011</td><td>20ms</td><td>1011</td><td>800ms</td></tr> <tr><td>0100</td><td>40ms</td><td>1100</td><td>1000ms</td></tr> <tr><td>0101</td><td>60ms</td><td>1101</td><td>1500ms</td></tr> <tr><td>0110</td><td>80ms</td><td>1110</td><td>2000ms</td></tr> <tr><td>0111</td><td>100ms</td><td>1111</td><td>4000ms</td></tr> </tbody> </table>	OFF_DELAY[3:0]	DELAY TIME	OFF_DELAY[3:0]	DELAY TIME	0000	0ms	1000	200ms	0001	5ms	1001	400ms	0010	10ms	1010	600ms	0011	20ms	1011	800ms	0100	40ms	1100	1000ms	0101	60ms	1101	1500ms	0110	80ms	1110	2000ms	0111	100ms	1111	4000ms
OFF_DELAY[3:0]	DELAY TIME	OFF_DELAY[3:0]	DELAY TIME																																			
0000	0ms	1000	200ms																																			
0001	5ms	1001	400ms																																			
0010	10ms	1010	600ms																																			
0011	20ms	1011	800ms																																			
0100	40ms	1100	1000ms																																			
0101	60ms	1101	1500ms																																			
0110	80ms	1110	2000ms																																			
0111	100ms	1111	4000ms																																			
11:8	ON_DELAY	<p>These bits determine the delay time to pin assertion (Notes 1 and 2):</p> <table border="0"> <thead> <tr> <th>ON_DELAY[3:0]</th> <th>DELAY TIME</th> <th>ON_DELAY[3:0]</th> <th>DELAY TIME</th> </tr> </thead> <tbody> <tr><td>0000</td><td>0ms</td><td>1000</td><td>200ms</td></tr> <tr><td>0001</td><td>5ms</td><td>1001</td><td>400ms</td></tr> <tr><td>0010</td><td>10ms</td><td>1010</td><td>600ms</td></tr> <tr><td>0011</td><td>20ms</td><td>1011</td><td>800ms</td></tr> <tr><td>0100</td><td>40ms</td><td>1100</td><td>1000ms</td></tr> <tr><td>0101</td><td>60ms</td><td>1101</td><td>1500ms</td></tr> <tr><td>0110</td><td>80ms</td><td>1110</td><td>2000ms</td></tr> <tr><td>0111</td><td>100ms</td><td>1111</td><td>4000ms</td></tr> </tbody> </table>	ON_DELAY[3:0]	DELAY TIME	ON_DELAY[3:0]	DELAY TIME	0000	0ms	1000	200ms	0001	5ms	1001	400ms	0010	10ms	1010	600ms	0011	20ms	1011	800ms	0100	40ms	1100	1000ms	0101	60ms	1101	1500ms	0110	80ms	1110	2000ms	0111	100ms	1111	4000ms
ON_DELAY[3:0]	DELAY TIME	ON_DELAY[3:0]	DELAY TIME																																			
0000	0ms	1000	200ms																																			
0001	5ms	1001	400ms																																			
0010	10ms	1010	600ms																																			
0011	20ms	1011	800ms																																			
0100	40ms	1100	1000ms																																			
0101	60ms	1101	1500ms																																			
0110	80ms	1110	2000ms																																			
0111	100ms	1111	4000ms																																			
7	PP_OD	0 = DAC/GPO push-pull output 1 = DAC/GPO open-drain output																																				
6	HI_LO	0 = DAC/GPO active low 1 = DAC/GPO active high																																				
5:3	0	These bits always return a 0.																																				
2:0	SELECT[2:0]	<p>These bits determine the function selected on the pin:</p> <table border="0"> <thead> <tr> <th>SELECT[2:0]</th> <th>GPO PIN SELECTED FUNCTION</th> </tr> </thead> <tbody> <tr><td>000</td><td>DAC operation</td></tr> <tr><td>001</td><td>Force GPO assertion</td></tr> <tr><td>010</td><td>Force GPO deassertion</td></tr> <tr><td>011</td><td>PG/GPI operation (use bits 31:16)</td></tr> <tr><td>100</td><td>Alarm operation (use bits 31:16)</td></tr> <tr><td>101</td><td>Reserved</td></tr> <tr><td>110</td><td>Reserved</td></tr> <tr><td>111</td><td>Reserved</td></tr> </tbody> </table>	SELECT[2:0]	GPO PIN SELECTED FUNCTION	000	DAC operation	001	Force GPO assertion	010	Force GPO deassertion	011	PG/GPI operation (use bits 31:16)	100	Alarm operation (use bits 31:16)	101	Reserved	110	Reserved	111	Reserved																		
SELECT[2:0]	GPO PIN SELECTED FUNCTION																																					
000	DAC operation																																					
001	Force GPO assertion																																					
010	Force GPO deassertion																																					
011	PG/GPI operation (use bits 31:16)																																					
100	Alarm operation (use bits 31:16)																																					
101	Reserved																																					
110	Reserved																																					
111	Reserved																																					

**Note 1:** ON\_DELAY and OFF\_DELAY are only available for the PG/GPI and ALARM options.

**Note 2:** The actual time delays are 2ms to 3ms longer than configured due to processing delays within the device.

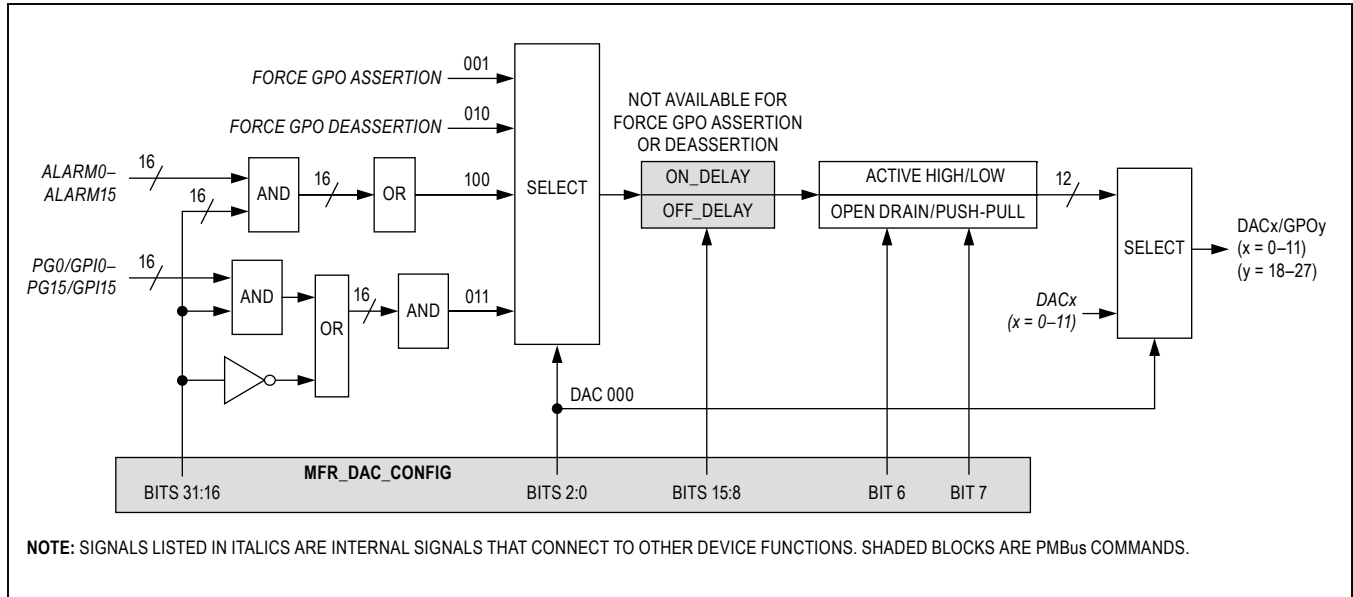

Figure 13. MFR\_DAC\_CONFIG Functional Logic

Table 38. MFR\_MARGIN\_CONFIG (DFh)

BIT	NAME	MEANING
15	SLOPE	DAC setting to resulting voltage relationship: 0 = Negative slope (higher DAC voltage results in a lower power-supply voltage) 1 = Positive slope (higher DAC voltage results in a higher power-supply voltage)
14	OPEN_LOOP	0 = Normal closed-loop margining 1 = DAC value set constantly to the DC_DAC value when margining invoked
13:8	0	These bits always return a 0.
7:0	DAC	This 8-bit value has two purposes. 1) Used as the initial DAC voltage when the device begins to margin a power supply either up or down. 2) When bit 14 is set, this value is used to set the DAC level.

**Delay Function**

If a delay is configured (either on or off), the input must be continuously static through the delay time before the output changes state (see Figure 9).

**MFR\_MARGIN\_CONFIG (DFh)**

The MFR\_MARGIN\_CONFIG command configures the internal voltage DACs to margin the associated power supplies. If the DAC pin is configured with the MFR\_DAC\_CONFIG for any function besides DAC operation, this selection overrides the margining functionality.

The MFR\_MARGIN\_CONFIG command is described in Table 38.

**Power-Supply Margining Operation**

For the power supplies connected to PSEN0 to PSEN15 (PAGES 0 to 15), power-supply margining is implemented using the DAC0 to DAC15 outputs, respectively. The device close-loop controls the DAC output voltage to margin the power supply. When margining is not active, the DAC outputs are high impedance unless the VOUT\_COMMAND is active.

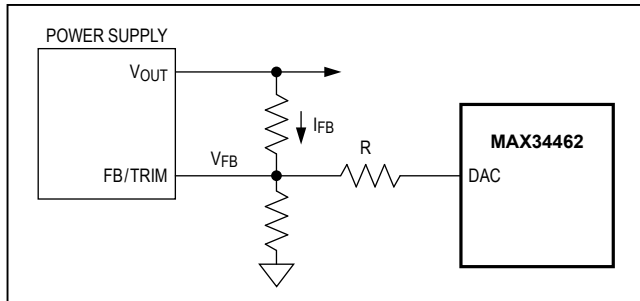

Figure 14. Margining Hardware Configurations

The device margins the power supplies when OPERATION is set to one of the margin states. Margining of the supplies does not begin until **all** power supplies have exceeded their programmed POWER\_GOOD\_ON levels. When this happens, the DAC output is enabled and margining is initiated. The device then averages four samples of VOUT for a total time of 20ms. If the measured VOUT and the target (set by either VOUT\_MARGIN\_HIGH or VOUT\_MARGIN\_LOW) differ by more than 1%, the DAC setting is adjusted by one step. The direction of the duty cycle adjustment is determined by the SLOPE bit in MFR\_MARGIN\_CONFIG. All changes to the DAC setting are made after averaging 4 samples of VOUT over a 20ms period.

When the OPERATION command deactivates margining and the margining has been running with the IGNORE ALL FAULTS condition, then the device does not begin monitoring for faults for 100ms after the MARGIN OFF input is received to allow time for the power supplies to return to a normal condition.

### Margining Faults

The device detects two possible margining faults. First, if the initial DAC step causes VOUT to exceed the target value (either high or low depending on whether the device has been instructed to margin high or low respectively), this creates a fault. Second, if the target value cannot be reached when the DAC reaches zero or full scale, this also creates a fault. If either margining fault occurs, the device continues attempting to margin the power supply and does the following:

- 1) Sets the MARGIN bit in STATUS\_WORD.
- 2) Sets the MARGIN\_FAULT bit in STATUS\_MFR\_SPECIFIC (PAGES 0 to 15).
- 3) Notifies the host through  $\overline{\text{ALERT}}$  assertion (if enabled in MFR\_MODE).

### DAC Value

The DAC value can be determined by the following formula.

$$\text{DAC Value} = 256 \times (V_{\text{FB}}/2.048)$$

where  $V_{\text{FB}}$  = power-supply feedback node voltage.

Example:

$$V_{\text{FB}} = 0.8\text{V}$$

$$\text{DAC Value} = 256 \times (0.8/2.048) = 100\text{d} = 0\text{x}64\text{h}$$

### DAC Margining Component Selection

The external components needed to realize the margining circuitry for the voltage DAC outputs are shown in [Figure 14](#) and described in the formulas below.

$$\text{DAC "R"} = (V_{\text{FB}} - 0.1)/(I_{\text{FB}} \times \text{Margining Range} \times 120\%)$$

where  $V_{\text{FB}}$  = feedback node voltage and  $I_{\text{FB}}$  = feedback node current.

Example:

$$V_{\text{FB}} = 0.8\text{V}, I_{\text{FB}} = 10\mu\text{A}, \text{Margining Range} = \pm 10\%$$

$$\text{DAC "R" Value} = (0.8 - 0.1)/(10\mu\text{A} \times 10\% \times 120\%) = 583\text{k}\Omega$$

### Temperature Sensor Operation

The device can monitor up to five different temperature sensors—four external sensors plus its own internal temperature sensor. The external temperature sensors are all connected in parallel to the master I<sup>2</sup>C port (MSDA and MSCL pins). The device can support up to four DS75LV devices.

Each of the enabled temperature sensors are measured once a second. The internal temperature sensor is averaged four times to reduce the affect of noise. Each time the device attempts to read a temperature sensor, it checks for faults. For the internal temperature sensor, a fault is defined as reading greater than +130°C or less than -60°C. For the I<sup>2</sup>C temperature sensors, a fault is defined as a communication access failure. Temperature sensor faults are reported by setting the temperature reading to 7FFFh. A temperature sensor fault results in the setting of the TEMPERATURE bit in STATUS\_WORD and  $\overline{\text{ALERT}}$  is asserted (if enabled in MFR\_MODE). No bits are set in STATUS\_TEMPERATURE. On device reset, if the device cannot initialize the external DS75LV device, the TEMPERATURE bit in STATUS\_WORD is set and  $\overline{\text{ALERT}}$  is asserted (if enabled in MFR\_MODE), but the device does not attempt to reinitialize the DS75LV until 8000h is written to MFR\_TEMP\_SENSOR\_CONFIG. Reading disabled temperature sensors returns a fixed value of 0000h.

Up to four DS75LV digital temperature sensors can be controlled by the MAX34462. The A0/1/2 pins on the DS75LV should be configured as shown in [Table 39](#). The thermostat function on the DS75LV is not used, therefore the O.S. output should be left open circuit.

### MFR\_TEMP\_SENSOR\_CONFIG (F0h)

The MFR\_TEMP\_SENSOR\_CONFIG command is used to configure the temperature sensors. The MFR\_TEMP\_SENSOR\_CONFIG command is described in [Table 40](#).

### MFR\_GPO\_CONFIG (F8h)

The MFR\_GPO\_CONFIG command is used to configure the individual GPO28 to GPO34 pins. There is a separate PMBus PAGE for each GPO output. See [Table 41](#) for details. Some of these pins share functions with alternate functions such as  $\overline{\text{FAULT}}$  outputs and the  $\overline{\text{SEQ}}$  output. This command should not be changed while the power

**Table 39. DS75LV Address Pin Configuration**

PAGE	MAX34462 TEMP SENSOR	DS75LV ADDRESS PIN CONFIGURATION		
		A2	A1	A0
16	MAX34462 internal	—	—	—
17	DS75LV (address 90h)	0	0	0
18	DS75LV (address 92h)	0	0	1
19	DS75LV (address 94h)	0	1	0
20	DS75LV (address 96h)	0	1	1

**Table 40. MFR\_TEMP\_SENSOR\_CONFIG (F0h)**

BIT	NAME	MEANING
15	ENABLE	0 = Temperature sensor disabled 1 = Temperature sensor enabled
14:0	0	These bits always return a 0.

**Table 41. GPO Description**

NAME	BALL	PMBus PAGE	NON-GPO PIN FUNCTION WHEN SELECT[2:0] = 000
GPO28	J9	21	$\overline{\text{FAULT0}}$
GPO29	K10	22	$\overline{\text{FAULT1}}$
GPO30	J10	23	$\overline{\text{FAULT2}}$
GPO31	H9	24	$\overline{\text{FAULT3}}$
GPO32	D7	25	$\overline{\text{SEQ}}$
GPO33	E5	26	High impedance
GPO34	E10	27	High impedance
GPO35	D10	28	SYNC

supplies are operating. The MFR\_GPO\_CONFIG command is described in the [Table 42](#) and [Figure 15](#).

Each GPO pin can be independently configured using the SELECT[2:0] bits to one of the following:

- Non-GPO Function (see [Table 41](#)) (SELECT[2:0] = 000)
- Force pin assertion (SELECT[2:0] = 001)
- Force pin deassertion (SELECT[2:0] = 010)
- Assert when all enabled channel power-good (PG) or GPI are asserted (SELECT[2:0] = 011)
- Assert when any enabled alarm goes active (SELECT[2:0] = 100)

Also each GPO pin can be independently configured to be either active high or active low and either push-pull or open drain using the HI\_LO and PP\_OD bits, respectively.

If SELECT[2:0] = 011, the GPO output is configured to assert when some combination of power-goods (PG) and general purpose inputs (GPI) from each channel are asserted. Which channels should be used in this combination are selected using the PG\_GPI\_SELECT bits (bit 16 to 31). If the PG\_GPI\_SELECT bit is cleared, then the associated channel is not used in the logical combination to assert the GPO output. If the PG\_GPI\_SELECT bit is set, then the power-good or GPI from this channel is used in the logical combination to assert the GPO output. This function is useful in creating system power-good signals.

If SELECT[2:0] = 100, the GPO output is configured to assert when any of the enabled channel alarms goes active. The channel alarms are enabled with the ALARM\_SELECT bits (bit 16 to 31). If the ALARM\_SELECT bit is cleared, then the alarm from this channel is blocked. If the ALARM\_SELECT bit is set, then the alarm from this channel is routed to an OR function such that any enabled alarm asserts the GPO output. The alarm function is chosen with the ALARM\_CONFIG bits in the MFR\_FAULT\_RESPONSE command. This function is useful in system debug or for enabling system status LEDs.

**Table 42. MFR\_GPO\_CONFIG (F8h)**

BIT	NAME	MEANING																																				
31:16	PG_GPI_SELECT ALARM_SELECT	<p>These bits are only used if SELECT[2:0] = 011 or 100; each bit corresponds to one channel (device channel N + 16 = bit number):</p> <table border="0"> <thead> <tr> <th>SELECT[2:0]</th> <th>BIT FUNCTION</th> </tr> </thead> <tbody> <tr> <td>011</td> <td>When this bit is cleared, the power-good (PG) or GPI from channel N is not used in the logical AND to assert the GPO output. When this bit is set, the PG or GPI is used.</td> </tr> <tr> <td>100</td> <td>When this bit is cleared, the alarm from channel N is blocked from the logical OR to assert the GPO output. When this bit is set, the alarm signal is routed to the logical OR.</td> </tr> </tbody> </table>	SELECT[2:0]	BIT FUNCTION	011	When this bit is cleared, the power-good (PG) or GPI from channel N is not used in the logical AND to assert the GPO output. When this bit is set, the PG or GPI is used.	100	When this bit is cleared, the alarm from channel N is blocked from the logical OR to assert the GPO output. When this bit is set, the alarm signal is routed to the logical OR.																														
SELECT[2:0]	BIT FUNCTION																																					
011	When this bit is cleared, the power-good (PG) or GPI from channel N is not used in the logical AND to assert the GPO output. When this bit is set, the PG or GPI is used.																																					
100	When this bit is cleared, the alarm from channel N is blocked from the logical OR to assert the GPO output. When this bit is set, the alarm signal is routed to the logical OR.																																					
15:12	OFF_DELAY	<p>These bits determine the delay time to pin deassertion (Notes 1 and 2):</p> <table border="0"> <thead> <tr> <th>OFF_DELAY[3:0]</th> <th>DELAY TIME</th> <th>OFF_DELAY[3:0]</th> <th>DELAY TIME</th> </tr> </thead> <tbody> <tr> <td>0000</td> <td>0ms</td> <td>1000</td> <td>200ms</td> </tr> <tr> <td>0001</td> <td>5ms</td> <td>1001</td> <td>400ms</td> </tr> <tr> <td>0010</td> <td>10ms</td> <td>1010</td> <td>600ms</td> </tr> <tr> <td>0011</td> <td>20ms</td> <td>1011</td> <td>800ms</td> </tr> <tr> <td>0100</td> <td>40ms</td> <td>1100</td> <td>1000ms</td> </tr> <tr> <td>0101</td> <td>60ms</td> <td>1101</td> <td>1500ms</td> </tr> <tr> <td>0110</td> <td>80ms</td> <td>1110</td> <td>2000ms</td> </tr> <tr> <td>0111</td> <td>100ms</td> <td>1111</td> <td>4000ms</td> </tr> </tbody> </table>	OFF_DELAY[3:0]	DELAY TIME	OFF_DELAY[3:0]	DELAY TIME	0000	0ms	1000	200ms	0001	5ms	1001	400ms	0010	10ms	1010	600ms	0011	20ms	1011	800ms	0100	40ms	1100	1000ms	0101	60ms	1101	1500ms	0110	80ms	1110	2000ms	0111	100ms	1111	4000ms
OFF_DELAY[3:0]	DELAY TIME	OFF_DELAY[3:0]	DELAY TIME																																			
0000	0ms	1000	200ms																																			
0001	5ms	1001	400ms																																			
0010	10ms	1010	600ms																																			
0011	20ms	1011	800ms																																			
0100	40ms	1100	1000ms																																			
0101	60ms	1101	1500ms																																			
0110	80ms	1110	2000ms																																			
0111	100ms	1111	4000ms																																			
11:8	ON_DELAY	<p>These bits determine the delay time to pin assertion (Notes 1 and 2):</p> <table border="0"> <thead> <tr> <th>ON_DELAY[3:0]</th> <th>DELAY TIME</th> <th>ON_DELAY[3:0]</th> <th>DELAY TIME</th> </tr> </thead> <tbody> <tr> <td>0000</td> <td>0ms</td> <td>1000</td> <td>200ms</td> </tr> <tr> <td>0001</td> <td>5ms</td> <td>1001</td> <td>400ms</td> </tr> <tr> <td>0010</td> <td>10ms</td> <td>1010</td> <td>600ms</td> </tr> <tr> <td>0011</td> <td>20ms</td> <td>1011</td> <td>800ms</td> </tr> <tr> <td>0100</td> <td>40ms</td> <td>1100</td> <td>1000ms</td> </tr> <tr> <td>0101</td> <td>60ms</td> <td>1101</td> <td>1500ms</td> </tr> <tr> <td>0110</td> <td>80ms</td> <td>1110</td> <td>2000ms</td> </tr> <tr> <td>0111</td> <td>100ms</td> <td>1111</td> <td>4000ms</td> </tr> </tbody> </table>	ON_DELAY[3:0]	DELAY TIME	ON_DELAY[3:0]	DELAY TIME	0000	0ms	1000	200ms	0001	5ms	1001	400ms	0010	10ms	1010	600ms	0011	20ms	1011	800ms	0100	40ms	1100	1000ms	0101	60ms	1101	1500ms	0110	80ms	1110	2000ms	0111	100ms	1111	4000ms
ON_DELAY[3:0]	DELAY TIME	ON_DELAY[3:0]	DELAY TIME																																			
0000	0ms	1000	200ms																																			
0001	5ms	1001	400ms																																			
0010	10ms	1010	600ms																																			
0011	20ms	1011	800ms																																			
0100	40ms	1100	1000ms																																			
0101	60ms	1101	1500ms																																			
0110	80ms	1110	2000ms																																			
0111	100ms	1111	4000ms																																			
7	PP_OD	0 = GPO push-pull output 1 = GPO open-drain output																																				
6	HI_LO	0 = GPO active low 1 = GPO active high																																				
5:3	0	These bits always return a 0.																																				
2:0	SELECT[2:0]	<p>These bits determine the function selected on the pin:</p> <table border="0"> <thead> <tr> <th>SELECT[2:0]</th> <th>GPO PIN SELECTED FUNCTION</th> </tr> </thead> <tbody> <tr> <td>000</td> <td>Non-GPO operation</td> </tr> <tr> <td>001</td> <td>Force GPO assertion</td> </tr> <tr> <td>010</td> <td>Force GPO deassertion</td> </tr> <tr> <td>011</td> <td>PG/GPI operation (use bits 31:16)</td> </tr> <tr> <td>100</td> <td>Alarm operation (use bits 31:16)</td> </tr> <tr> <td>101</td> <td>Reserved</td> </tr> <tr> <td>110</td> <td>Reserved</td> </tr> <tr> <td>111</td> <td>Reserved</td> </tr> </tbody> </table>	SELECT[2:0]	GPO PIN SELECTED FUNCTION	000	Non-GPO operation	001	Force GPO assertion	010	Force GPO deassertion	011	PG/GPI operation (use bits 31:16)	100	Alarm operation (use bits 31:16)	101	Reserved	110	Reserved	111	Reserved																		
SELECT[2:0]	GPO PIN SELECTED FUNCTION																																					
000	Non-GPO operation																																					
001	Force GPO assertion																																					
010	Force GPO deassertion																																					
011	PG/GPI operation (use bits 31:16)																																					
100	Alarm operation (use bits 31:16)																																					
101	Reserved																																					
110	Reserved																																					
111	Reserved																																					

**Note 1:** ON\_DELAY and OFF\_DELAY are only available for PG/GPI and ALARM.

**Note 2:** The actual time delays are 2ms to 3ms longer than configured due to processing delays within the device.

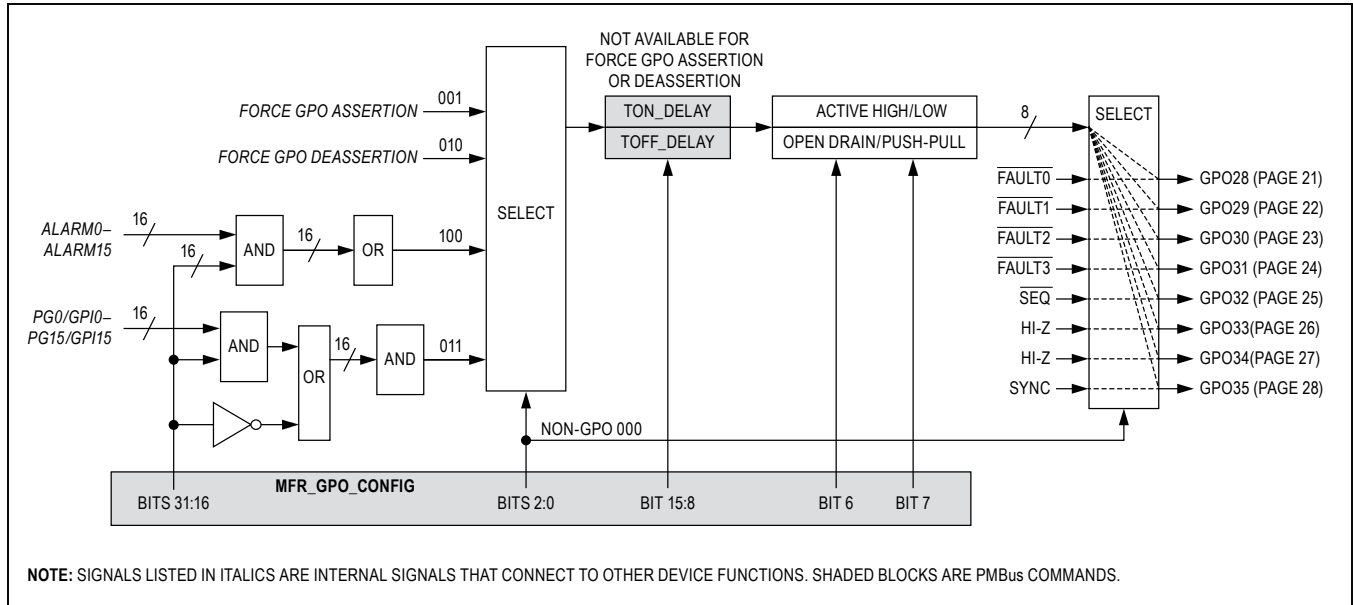

Figure 15. MFR\_GPO\_CONFIG Functional Logic

**Delay Function**

If a delay is configured (either on or off), the input must be continuously static through the delay time before the output changes state. See [Figure 9](#).

**Applications Information**

**DVDD, AVDD, VREF, and REG18 Decoupling**

To achieve the best results when using the device, decouple each DVDD and AVDD power input with a 0.1µF capacitor. All DVDD and AVDD pins should be connected together. All DVSS and AVSS pins should be connected together. Use high-quality, ceramic, surface-mount capacitors. Surface-mount components minimize lead inductance, which improves performance, and ceramic capacitors tend to have adequate high-frequency response for decoupling applications. Decouple the REG18 regulator output using 1µF (maximum ESR of 500mΩ) and 10nF capacitors and decouple REG18A with a 0.1µF capacitor. Decouple the VREF output using a 22nF capacitor.

**Open-Drain Pins**

MSDA, MSCL, SCL, SDA, *FAULT*, *SEQ*, PSEN, and ALERT are open-drain pins and require external pullup resistors connected to DVDD to realize high logic levels.

**Keep-Alive Circuit**

In systems where the power to the MAX34462 may be not always be present, a keep-alive circuit consisting of a

Schottky diode and a bulk capacitor can be added to allow the device time to orderly shutdown the power supplies it is controlling before power is lost.

**Configuration Port**

Some applications may require the ability to configure the MAX34462 when the device has been mounted on a PCB. In such applications, a 3- or 4-wire header can be added to allow access to the slave I<sup>2</sup>C pins.

**Resistor-Dividers and Source Impedance for RS Inputs**

The maximum full-scale voltage on the ADC inputs is 2.048V (nominal). A resistor-divider must be used to measure voltages greater than 1.8V. The maximum source impedance to the RS inputs when voltage is measured is determined by the ADC\_TIME bits in MFR\_MODE. See the [Recommended Operating Conditions](#) section for more details.

**Protecting Input Pins**

In applications where voltages can be applied to the RS/ GPI, SYNC, or CONTROL signals when V<sub>DD</sub> or V<sub>DDA</sub> is grounded or open, a series 100Ω resistor is recommended to protect the device by limiting power dissipation.

Typical Operating Circuit

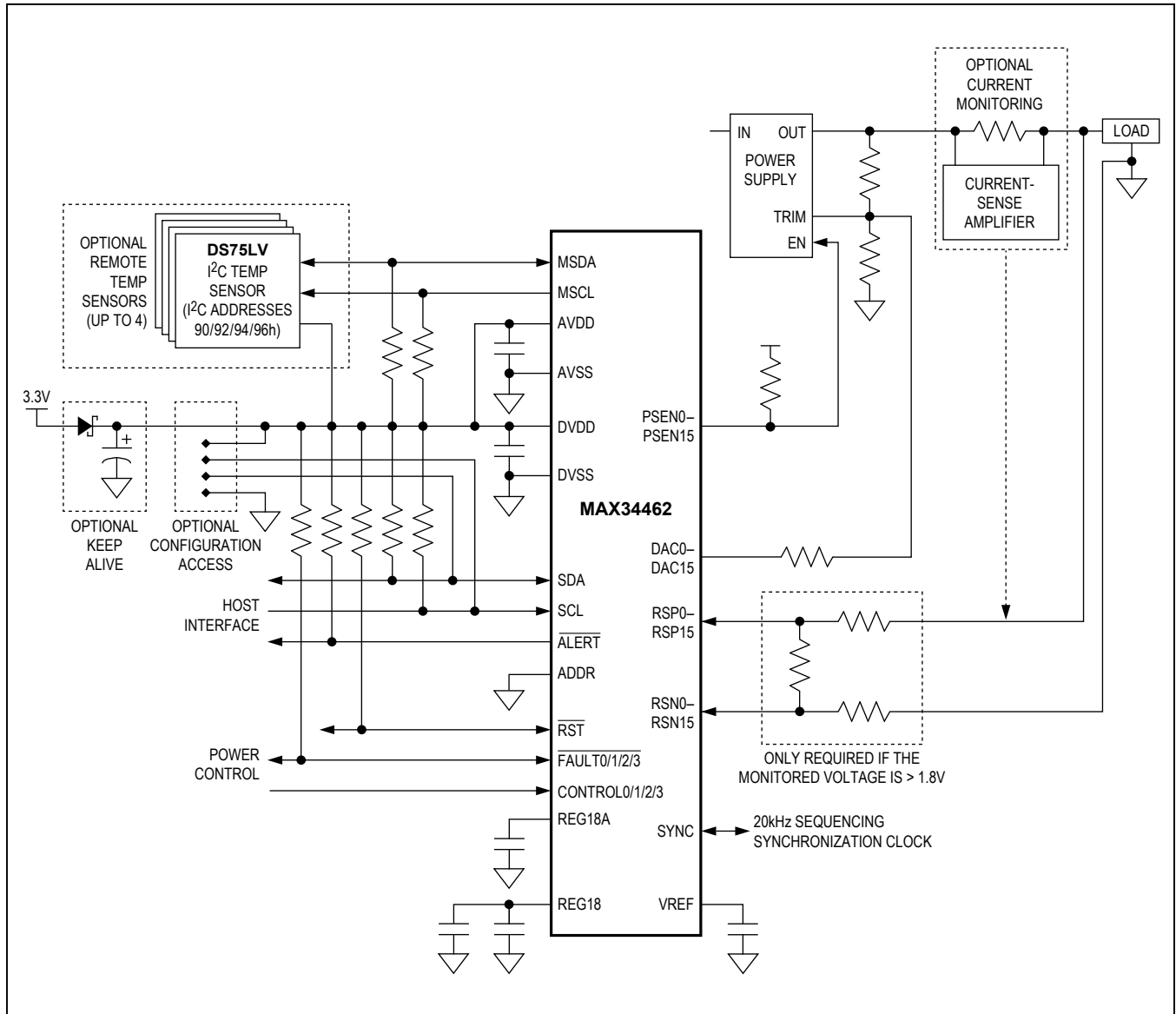

### Ordering Information

PART	TEMP RANGE	PIN-PACKAGE
MAX34462EXQ+	-40°C to +95°C	100 CSBGA
MAX34462EXQ+T	-40°C to +95°C	100 CSBGA

+Denotes a lead(Pb)-free/RoHS-compliant package.

T = Tape and reel.

### Package Information

For the latest package outline information and land patterns (footprints), go to [www.maximintegrated.com/packages](http://www.maximintegrated.com/packages). Note that a "+", "#", or "-" in the package code indicates RoHS status only. Package drawings may show a different suffix character, but the drawing pertains to the package regardless of RoHS status.

PACKAGE TYPE	PACKAGE CODE	OUTLINE NO.	LAND PATTERN NO.
100 CSBGA	X10011+1	<a href="#">21-0352</a>	<a href="#">90-0292</a>

## Revision History

REVISION NUMBER	REVISION DATE	DESCRIPTION	PAGES CHANGED
0	9/13	Initial release	—

For pricing, delivery, and ordering information, please contact Maxim Direct at 1-888-629-4642, or visit Maxim Integrated's website at [www.maximintegrated.com](http://www.maximintegrated.com).

*Maxim Integrated cannot assume responsibility for use of any circuitry other than circuitry entirely embodied in a Maxim Integrated product. No circuit patent licenses are implied. Maxim Integrated reserves the right to change the circuitry and specifications without notice at any time. The parametric values (min and max limits) shown in the Electrical Characteristics table are guaranteed. Other parametric values quoted in this data sheet are provided for guidance.*

## Looking for pricing, stock, or lifecycle information?

Click below to explore more details on WIN SOURCE:

 [View MAX34462EXQ+ on WIN SOURCE](#)

 [Maxim Integrated](#) Information

## Optimize Your Supply Chain with WIN SOURCE Solutions

-  Global Sourcing Solution
-  Obsolete Management
-  Cost Control Management
-  Shortage Management
-  Alternative Solution
-  Excess Inventory Management