

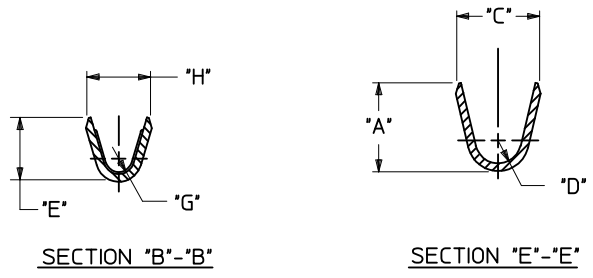

THE DATASHEET OF
0430310001-06-B2-D





WIRE SIZE	MAX. INSULATION
18 OR 0.75mm ² (SEE NOTE 11)	.073/(1.85)
20-24	.073/(1.85)
26-30	.050/(1.27)

ITEM NUMBER	PLATING OPTION	WIRE SIZE	ASSEMBLY OPTION	"A" ±.016 (±0.41)	"C" ±.012 (±0.30)	"D" ±.005 (±0.13)	"E" ±.016 (±0.41)	"G" ±.005 (±0.13)	"H" ±.012 (±0.30)
43031-0001	A	20-24	CHAIN	.090/(2.29)	.100/(2.54)	.030/(0.76) R.	.075/(1.91)	.025/(0.64) R.	.082/(2.08)
43031-0002	B	20-24	CHAIN	.090/(2.29)	.100/(2.54)	.030/(0.76) R.	.075/(1.91)	.025/(0.64) R.	.082/(2.08)
43031-0003	C	20-24	CHAIN	.090/(2.29)	.100/(2.54)	.030/(0.76) R.	.075/(1.91)	.025/(0.64) R.	.082/(2.08)
43031-0004	A	26-30	CHAIN	.075/(1.91)	.083/(2.10)	.025/(0.64) R.	.058/(1.47)	.020/(0.51) R.	.065/(1.65)
43031-0005	B	26-30	CHAIN	.075/(1.91)	.083/(2.10)	.025/(0.64) R.	.058/(1.47)	.020/(0.51) R.	.065/(1.65)
43031-0006	C	26-30	CHAIN	.075/(1.91)	.083/(2.10)	.025/(0.64) R.	.058/(1.47)	.020/(0.51) R.	.065/(1.65)
43031-0007	A	20-24	LOOSE	.090/(2.29)	.100/(2.54)	.030/(0.76) R.	.075/(1.91)	.025/(0.64) R.	.082/(2.08)
43031-0008	B	20-24	LOOSE	.090/(2.29)	.100/(2.54)	.030/(0.76) R.	.075/(1.91)	.025/(0.64) R.	.082/(2.08)
43031-0009	C	20-24	LOOSE	.090/(2.29)	.100/(2.54)	.030/(0.76) R.	.075/(1.91)	.025/(0.64) R.	.082/(2.08)
43031-0010	A	26-30	LOOSE	.075/(1.91)	.083/(2.10)	.025/(0.64) R.	.058/(1.47)	.020/(0.51) R.	.065/(1.65)
43031-0011	B	26-30	LOOSE	.075/(1.91)	.083/(2.10)	.025/(0.64) R.	.058/(1.47)	.020/(0.51) R.	.065/(1.65)
43031-0012	C	26-30	LOOSE	.075/(1.91)	.083/(2.10)	.025/(0.64) R.	.058/(1.47)	.020/(0.51) R.	.065/(1.65)
43031-0021	A	18 OR 0.75mm ² (SEE NOTE 11)	CHAIN	.090/(2.29)	.100/(2.54)	.030/(0.76) R.	.086/(2.18)	.029/(0.74) R.	.094/(2.39)
43031-0022	B	18 OR 0.75mm ² (SEE NOTE 11)	CHAIN	.090/(2.29)	.100/(2.54)	.030/(0.76) R.	.086/(2.18)	.029/(0.74) R.	.094/(2.39)
43031-0023	C	18 OR 0.75mm ² (SEE NOTE 11)	CHAIN	.090/(2.29)	.100/(2.54)	.030/(0.76) R.	.086/(2.18)	.029/(0.74) R.	.094/(2.39)

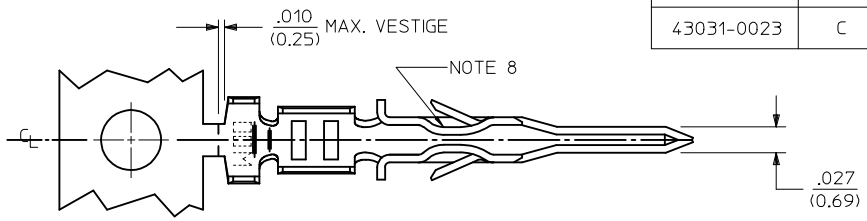

- NOTES:
- 1) MATERIAL: PHOSPHOR BRONZE ALLOY
 - 2) TERMINAL PLATING:
 "A" = HOT TIN DIP: .000040/(0.00102) MIN.
 "B" = .000015/(0.00038) MIN. SELECT GOLD
 .000100/(0.00254) MIN. SELECT TIN
 OVER .000050/(0.00127) MIN. NICKEL
 "C" = .000030/(0.00076) MIN. SELECT GOLD
 .000100/(0.00254) MIN. SELECT TIN
 OVER .000050/(0.00127) MIN. NICKEL
 * MATERIAL NUMBERS WITH SELECT PLATING ARE
 POST-PLATED AFTER FORMING
 - 3) PRODUCT SPECIFICATION: PS-43045, PS-43650, PS-44300-001.
 - 4) PACKAGING SPECIFICATION: PK-43031-001 (REEL), AND PK-43030-003 (LOOSE).
 - 5) TERMINAL FOR USE IN MICRO FIT PLUG SERIES 43020, 43640, 44300, AND 46625.
 - 6) FOR TERMINAL ORIENTATION IN PLUG SEE DRAWINGS FOR PLUG HOUSINGS.
 - 7) THIS TERMINAL IS DESIGNED IN METRIC.
 - 8) TERMINAL MAY HAVE AN INWARD OR OUTWARD FORMED SHAPE IN THIS AREA.
 - 9) SOME GOLD MAY BE PRESENT ON INSIDE SURFACE.
 - 10) TEXT ON PART IS FOR REFERENCE ONLY. TEXT AND TEXT LOCATION MAY VARY DEPENDING ON PART NUMBER AND/OR TOOL.
 - 11) PART NUMBERS FOR 18 AWG OR 0.75 mm² ARE DESIGNED FOR 1061 STYLE WIRE OR A .073/1.85 MAXIMUM INSULATION OUTSIDE DIAMETER.

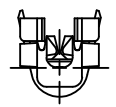
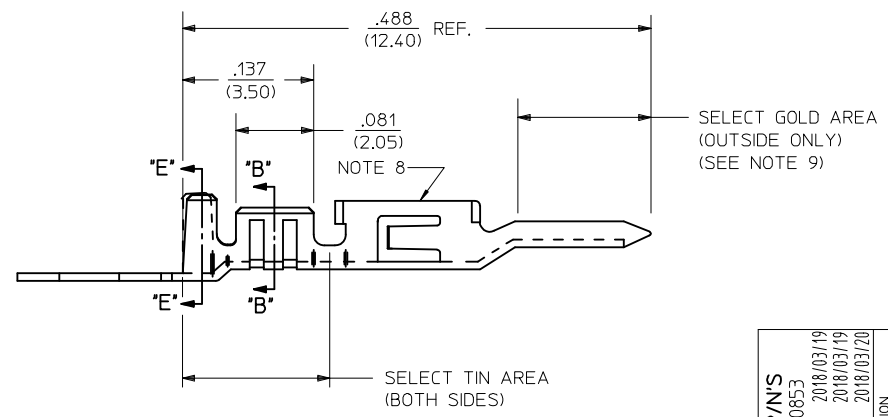

ADD 18AWG P/N'S EC NO: UCP2018-0853 DRWNS:SSOUSEK 2018/03/19 CHKD:JBELL 2018/03/19 APPR:FSMITH 2018/03/20	QUALITY SYMBOLS ∇=0 ∇=0 ∇=0	GENERAL TOLERANCES (UNLESS SPECIFIED)		DIMENSION STYLE IN/MM		SCALE	DESIGN UNITS METRIC	THIRD ANGLE PROJECTION		
		mm		INCH		DRAWN BY DATE		TITLE		
		4 PLACES ± ---		± ---		MUELLER 2002/08/13		MICRO-FIT (3.0) MALE TERMINAL		
		3 PLACES ± ---		±.014		CHECKED BY DATE		molex		
2 PLACES ± 0.25		±.010		MUELLER 2002/08/13		APPROVED BY DATE		DOCUMENT NO.		
1 PLACE ± 0.35		± ---		MARGULIS 2002/08/13		MATERIAL NO.		SD-43031-****		
0 PLACE ±		±				SHEET NO.		1 OF 1		
K2		ANGULAR ±1/2°		DRAFT WHERE APPLICABLE MUST REMAIN WITHIN DIMENSIONS		THIS DRAWING CONTAINS INFORMATION THAT IS PROPRIETARY TO MOLEX INCORPORATED AND SHOULD NOT BE USED WITHOUT WRITTEN PERMISSION				

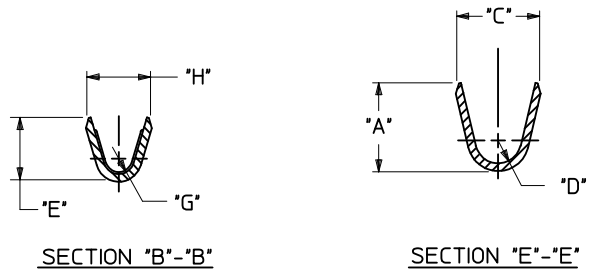

WIRE SIZE	MAX. INSULATION
18 OR 0.75mm ² (SEE NOTE 11)	.073/(1.85)
20-24	.073/(1.85)
26-30	.050/(1.27)

ITEM NUMBER	PLATING OPTION	WIRE SIZE	ASSEMBLY OPTION	"A" ±.016 (±0.41)	"C" ±.012 (±0.30)	"D" ±.005 (±0.13)	"E" ±.016 (±0.41)	"G" ±.005 (±0.13)	"H" ±.012 (±0.30)
43031-0001	A	20-24	CHAIN	.090/(2.29)	.100/(2.54)	.030/(0.76) R.	.075/(1.91)	.025/(0.64) R.	.082/(2.08)
43031-0002	B	20-24	CHAIN	.090/(2.29)	.100/(2.54)	.030/(0.76) R.	.075/(1.91)	.025/(0.64) R.	.082/(2.08)
43031-0003	C	20-24	CHAIN	.090/(2.29)	.100/(2.54)	.030/(0.76) R.	.075/(1.91)	.025/(0.64) R.	.082/(2.08)
43031-0004	A	26-30	CHAIN	.075/(1.91)	.083/(2.10)	.025/(0.64) R.	.058/(1.47)	.020/(0.51) R.	.065/(1.65)
43031-0005	B	26-30	CHAIN	.075/(1.91)	.083/(2.10)	.025/(0.64) R.	.058/(1.47)	.020/(0.51) R.	.065/(1.65)
43031-0006	C	26-30	CHAIN	.075/(1.91)	.083/(2.10)	.025/(0.64) R.	.058/(1.47)	.020/(0.51) R.	.065/(1.65)
43031-0007	A	20-24	LOOSE	.090/(2.29)	.100/(2.54)	.030/(0.76) R.	.075/(1.91)	.025/(0.64) R.	.082/(2.08)
43031-0008	B	20-24	LOOSE	.090/(2.29)	.100/(2.54)	.030/(0.76) R.	.075/(1.91)	.025/(0.64) R.	.082/(2.08)
43031-0009	C	20-24	LOOSE	.090/(2.29)	.100/(2.54)	.030/(0.76) R.	.075/(1.91)	.025/(0.64) R.	.082/(2.08)
43031-0010	A	26-30	LOOSE	.075/(1.91)	.083/(2.10)	.025/(0.64) R.	.058/(1.47)	.020/(0.51) R.	.065/(1.65)
43031-0011	B	26-30	LOOSE	.075/(1.91)	.083/(2.10)	.025/(0.64) R.	.058/(1.47)	.020/(0.51) R.	.065/(1.65)
43031-0012	C	26-30	LOOSE	.075/(1.91)	.083/(2.10)	.025/(0.64) R.	.058/(1.47)	.020/(0.51) R.	.065/(1.65)
43031-0021	A	18 OR 0.75mm ² (SEE NOTE 11)	CHAIN	.090/(2.29)	.100/(2.54)	.030/(0.76) R.	.086/(2.18)	.029/(0.74) R.	.094/(2.39)
43031-0022	B	18 OR 0.75mm ² (SEE NOTE 11)	CHAIN	.090/(2.29)	.100/(2.54)	.030/(0.76) R.	.086/(2.18)	.029/(0.74) R.	.094/(2.39)
43031-0023	C	18 OR 0.75mm ² (SEE NOTE 11)	CHAIN	.090/(2.29)	.100/(2.54)	.030/(0.76) R.	.086/(2.18)	.029/(0.74) R.	.094/(2.39)

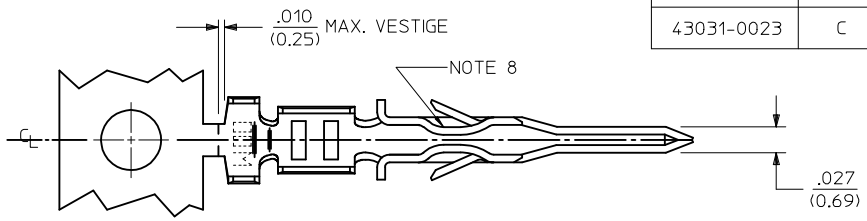

- NOTES:
- MATERIAL: PHOSPHOR BRONZE ALLOY
 - TERMINAL PLATING:
 "A" = HOT TIN DIP: .000040/(0.00102) MIN.
 "B" = .000015/(0.00038) MIN. SELECT GOLD
 .000100/(0.00254) MIN. SELECT TIN
 OVER .000050/(0.00127) MIN. NICKEL
 "C" = .000030/(0.00076) MIN. SELECT GOLD
 .000100/(0.00254) MIN. SELECT TIN
 OVER .000050/(0.00127) MIN. NICKEL
 * MATERIAL NUMBERS WITH SELECT PLATING ARE
 POST-PLATED AFTER FORMING
 - PRODUCT SPECIFICATION: PS-43045, PS-43650, PS-44300-001.
 - PACKAGING SPECIFICATION: PK-43031-001 (REEL), AND PK-43030-003 (LOOSE).
 - TERMINAL FOR USE IN MICRO FIT PLUG SERIES 43020, 43640, 44300, AND 46625.
 - FOR TERMINAL ORIENTATION IN PLUG SEE DRAWINGS FOR PLUG HOUSINGS.
 - THIS TERMINAL IS DESIGNED IN METRIC.
 - TERMINAL MAY HAVE AN INWARD OR OUTWARD FORMED SHAPE IN THIS AREA.
 - SOME GOLD MAY BE PRESENT ON INSIDE SURFACE.
 - TEXT ON PART IS FOR REFERENCE ONLY. TEXT AND TEXT LOCATION MAY VARY DEPENDING ON PART NUMBER AND/OR TOOL.
 - PART NUMBERS FOR 18 AWG OR 0.75 mm² ARE DESIGNED FOR 1061 STYLE WIRE OR A .073/1.85 MAXIMUM INSULATION OUTSIDE DIAMETER.

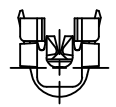
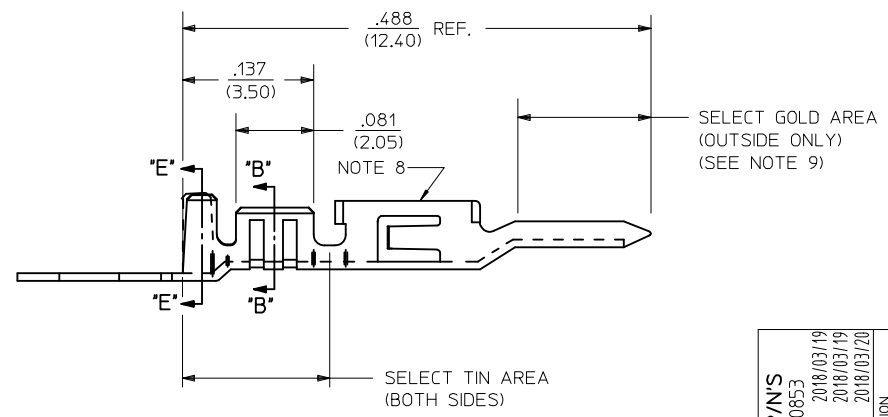

ADD 18AWG P/N'S EC NO: UCP2018-0853 DRWNS:SSOUSEK 2018/03/19 CHKD:JBELL 2018/03/19 APPR:FSMITH 2018/03/20	QUALITY SYMBOLS ∇=0 ∇=0 ∇=0	GENERAL TOLERANCES (UNLESS SPECIFIED)		DIMENSION STYLE IN/MM		SCALE	DESIGN UNITS METRIC	THIRD ANGLE PROJECTION		
		mm		INCH		DRAWN BY MUELLER	DATE 2002/08/13	TITLE MICRO-FIT (3.0) MALE TERMINAL		
		4 PLACES ± ---		± ---		CHECKED BY MUELLER	DATE 2002/08/13	MATERIAL NO. SEE CHART		
		3 PLACES ± ---		±.014		APPROVED BY MARGULIS	DATE 2002/08/13	DOCUMENT NO. SD-43031-****		SHEET NO. 1 OF 1
2 PLACES ± 0.25		±.010		DRAFT WHERE APPLICABLE MUST REMAIN WITHIN DIMENSIONS						
1 PLACE ± 0.35		± ---		THIS DRAWING CONTAINS INFORMATION THAT IS PROPRIETARY TO MOLEX INCORPORATED AND SHOULD NOT BE USED WITHOUT WRITTEN PERMISSION						
0 PLACE ±		±								

Looking for pricing, stock, or lifecycle information?

Click below to explore more details on WIN SOURCE:

 [View 0430310001-06-B2-D on WIN SOURCE](#)

 [Molex, LLC Information](#)

Optimize Your Supply Chain with WIN SOURCE Solutions

-  Global Sourcing Solution
-  Obsolete Management
-  Cost Control Management
-  Shortage Management
-  Alternative Solution
-  Excess Inventory Management