



**THE DATASHEET OF  
MAX1364EUB+**





# 4-Channel, 12-Bit System Monitors with Programmable Trip Window and SMBus Alert Response

MAX1363/MAX1364

## General Description

The MAX1363/MAX1364 low-power, 12-bit, 4-channel analog-to-digital converters (ADCs) feature a digitally programmable window comparator with an interrupt output for automatic system-monitoring applications. Once configured, monitor mode automatically asserts an interrupt when any analog input exceeds the programmed upper or lower thresholds, without interaction to the host. The MAX1363/MAX1364 respond to the SMBus™ alert, allowing quick identification of the alarming device on a shared interrupt. A programmable delay between monitoring intervals lowers power consumption for reduced monitoring rates.

In addition, the MAX1363/MAX1364 integrate an internal voltage reference, a clock, and a 1.7MHz, high-speed, I<sup>2</sup>C-compatible, 2-wire serial interface. The optimized interface allows a maximum conversion rate of 94.4ksps in normal mode while reading back the conversion results. Each of the four analog inputs is configurable for single-ended or fully differential operation and unipolar or bipolar operation. Two scan modes utilize on-chip random access memory (RAM) to allow eight conversions of a selected channel or scanning of a group of channels to reduce interface overhead.

These devices operate from a single 2.7V to 3.6V (MAX1363) or 4.5V to 5.5V (MAX1364) supply and require only 436μA at the maximum sampling rate of 133ksps in monitor mode and 670μA at the maximum sampling rate of 94.4ksps. AutoShutdown™ powers down the devices between conversions, reducing supply current to less than 1μA when idle.

The full-scale analog-input range is determined by the internal reference or by an externally applied reference voltage ranging from 1V to V<sub>DD</sub>. The MAX1363 features a 2.048V internal reference, and the MAX1364 features a 4.096V internal reference.

The MAX1363/MAX1364 are available in a 10-pin μMAX® package and are specified over the extended (-40°C to +85°C) temperature range. For 10-bit applications, refer to the pin-compatible MAX1361/MAX1362 data sheet.

## Applications

System Monitoring/Supervision  
Servers/Workstations  
High-Reliability Power Supplies  
Medical Instrumentation

## Features

- ◆ **Monitor Mode**
  - Programmable Lower/Upper Trip Threshold
  - Alarm-Status Register Records Fault Events
  - SMBus Alert Response
  - Programmable Sampling Intervals
- ◆ **12-Bit, I<sup>2</sup>C-Compatible ADC**
  - ±1 LSB INL, ±1 LSB DNL
- ◆ **4-Channel Single-Ended or 2-Channel Fully Differential Inputs**
- ◆ **Software-Programmable Bipolar/Unipolar Conversions**
- ◆ **Fast Sampling Rate**
  - 94.4ksps While Continuously Reading Conversions
  - 133ksps in Monitor Mode
- ◆ **High-Speed, I<sup>2</sup>C-Compatible Serial Interface**
  - 100kHz/400kHz Standard/Fast Mode
  - Up to 1.7MHz High-Speed Mode
  - Six Available I<sup>2</sup>C Slave Addresses
- ◆ **Single Supply**
  - 2.7V to 3.6V (MAX1363)
  - 4.5V to 5.5V (MAX1364)
- ◆ **Internal Reference**
  - 2.048V (MAX1363)
  - 4.096V (MAX1364)
- ◆ **External Reference: 1V to V<sub>DD</sub>**
- ◆ **Low Power**
  - 436μA in Monitor Mode (133ksps)
  - 670μA at 94.4ksps
  - 6μA at 1ksps
  - 0.5μA in Power-Down Mode
- ◆ **Small Package**
  - 10-Pin μMAX

SMBus is a trademark of Intel Corporation.

AutoShutdown is a trademark of Maxim Integrated Products, Inc.  
μMAX is a registered trademark of Maxim Integrated Products, Inc.

Typical Operating Circuit and Pin Configuration appear at end of data sheet.

## Ordering Information/Selector Guide

PART	TEMP RANGE	PIN-PACKAGE	I <sup>2</sup> C SLAVE ADDRESS	SUPPLY VOLTAGE (V)
MAX1363EUB+	-40°C to +85°C	10 μMAX	0110100/0110101	2.7 to 3.6
MAX1363MEUB+	-40°C to +85°C	10 μMAX	0110110/0110111	2.7 to 3.6

+Denotes a lead-free package.

Ordering Information/Selector Guide continued at end of data sheet.



# 4-Channel, 12-Bit System Monitors with Programmable Trip Window and SMBus Alert Response

## ABSOLUTE MAXIMUM RATINGS

V <sub>DD</sub> to GND	-0.3V to +6V	Operating Temperature Range	-40°C to +85°C
A <sub>IN0</sub> –A <sub>IN3</sub> , A <sub>0</sub> , REF to GND	-0.3V to (V <sub>DD</sub> + 0.3V)	Junction Temperature	+150°C
SDA, SCL, I <sub>INT</sub> to GND	-0.3V to +6V	Storage Temperature Range	-60°C to +150°C
Maximum Current Into Any Pin	±50mA	Lead Temperature (soldering, 10s)	+300°C
Continuous Power Dissipation (T <sub>A</sub> = +70°C)			
10-Pin μMAX (derate 5.6mW/°C above +70°C)	444.4mW		

Stresses beyond those listed under "Absolute Maximum Ratings" may cause permanent damage to the device. These are stress ratings only, and functional operation of the device at these or any other conditions beyond those indicated in the operational sections of the specifications is not implied. Exposure to absolute maximum rating conditions for extended periods may affect device reliability.

## ELECTRICAL CHARACTERISTICS

(V<sub>DD</sub> = 2.7V to 3.6V (MAX1363), V<sub>DD</sub> = 4.5V to 5.5V (MAX1364), V<sub>REF</sub> = 2.048V (MAX1363), V<sub>REF</sub> = 4.096V (MAX1364), C<sub>REF</sub> = 0.1μF, f<sub>SCL</sub> = 1.7MHz, T<sub>A</sub> = T<sub>MIN</sub> to T<sub>MAX</sub>, unless otherwise noted. Typical values are at T<sub>A</sub> = +25°C.)

PARAMETER	SYMBOL	CONDITIONS	MIN	TYP	MAX	UNITS
<b>DC ACCURACY (f<sub>SAMPLE</sub> = 94.4ksps) (Note 1)</b>						
Resolution			12			Bits
Relative Accuracy	INL	(Note 2)			±1	LSB
Differential Nonlinearity	DNL	No missing codes			±1	LSB
Offset Error					±4	LSB
Offset-Error Temperature Coefficient		Relative to FSR		0.3		ppm/°C
Gain Error		(Note 3)			±4	LSB
Gain Temperature Coefficient		Relative to FSR		0.3		ppm/°C
Channel-to-Channel Offset Matching				±0.1		LSB
Channel-to-Channel Gain Matching				±0.1		LSB
<b>DYNAMIC PERFORMANCE (f<sub>IN(SINE-WAVE)</sub> = 10kHz, V<sub>IN(P-P)</sub> = V<sub>REF</sub>, f<sub>SAMPLE</sub> = 94.4ksps)</b>						
Signal-to-Noise Plus Distortion	SINAD			70		dB
Total Harmonic Distortion	THD	Up to the 5th harmonic		-78		dB
Spurious-Free Dynamic Range	SFDR			78		dB
Full-Power Bandwidth		SINAD > 57dB		3.0		MHz
Full-Linear Bandwidth		-3dB point		5.0		MHz
<b>CONVERSION RATE</b>						
Conversion Time (Note 4)	t <sub>CONV</sub>	Internal clock			7.5	μs
		External clock	10.6			
Throughput Rate (Note 5)	f <sub>SAMPLE</sub>	Internal clock, SCAN[1:0] = 01		51		ksps
		External clock			94.4	
		Monitor mode, SCAN[1:0] = 10			133	

## 4-Channel, 12-Bit System Monitors with Programmable Trip Window and SMBus Alert Response

### ELECTRICAL CHARACTERISTICS (continued)

( $V_{DD} = 2.7V$  to  $3.6V$  (MAX1363),  $V_{DD} = 4.5V$  to  $5.5V$  (MAX1364),  $V_{REF} = 2.048V$  (MAX1363),  $V_{REF} = 4.096V$  (MAX1364),  $C_{REF} = 0.1\mu F$ ,  $f_{SCL} = 1.7MHz$ ,  $T_A = T_{MIN}$  to  $T_{MAX}$ , unless otherwise noted. Typical values are at  $T_A = +25^\circ C$ .)

PARAMETER	SYMBOL	CONDITIONS	MIN	TYP	MAX	UNITS	
Track/Hold Acquisition Time			800			ns	
Internal Clock Frequency				2.8		MHz	
Aperture Delay (Note 6)	$t_{AD}$	External clock, fast mode		60		ns	
		External clock, high-speed mode		30			
<b>ANALOG INPUT (AIN0–AIN3)</b>							
Input Voltage Range, Single Ended and Differential (Note 7)		Unipolar	0		$V_{REF}$	V	
		Bipolar	$-V_{REF} / 2$		$+V_{REF} / 2$		
Input Multiplexer Leakage Current		ON/OFF-leakage current, $V_{AIN\_} = 0$ or $V_{DD}$		$\pm 0.01$	$\pm 1$	$\mu A$	
Input Capacitance	$C_{IN}$			22		pF	
<b>INTERNAL REFERENCE (Note 8)</b>							
Reference Voltage	$V_{REF}$	$T_A = +25^\circ C$	MAX1363	2.027	2.048	2.068	V
			MAX1364	4.055	4.096	4.137	
Reference-Voltage Temperature Coefficient	$TCV_{REF}$			25		ppm/ $^\circ C$	
REF Short-Circuit Current					2	mA	
REF Source Impedance				1.5		k $\Omega$	
<b>EXTERNAL REFERENCE</b>							
REF Input Voltage Range	$V_{REF}$	(Note 9)	1		$V_{DD}$	V	
REF Input Current	$I_{REF}$	$f_{SAMPLE} = 94.4ksps$			40	$\mu A$	
<b>DIGITAL INPUTS/OUTPUTS (SCL, SDA, A0)</b>							
Input High Voltage	$V_{IH}$		$0.7 \times V_{DD}$			V	
Input Low Voltage	$V_{IL}$			$0.3 \times V_{DD}$		V	
Input Hysteresis	$V_{HYST}$		$0.1 \times V_{DD}$			V	
Input Current	$I_{IN}$				$\pm 10$	$\mu A$	
Input Capacitance	$C_{IN}$			15		pF	
Output Low Voltage	$V_{OL}$	$I_{SINK} = 3mA$			0.4	V	
<b>INT OUTPUT</b>							
Output Low Voltage		$I_{SINK} = 3mA$			0.4	V	
INT Leakage Current		No faults detected			$\pm 10$	$\mu A$	
Output Capacitance				15		pF	
<b>POWER REQUIREMENTS</b>							
Supply Voltage	$V_{DD}$	MAX1363	2.7		3.6	V	
		MAX1364	4.5		5.5		

# 4-Channel, 12-Bit System Monitors with Programmable Trip Window and SMBus Alert Response

## ELECTRICAL CHARACTERISTICS (continued)

( $V_{DD} = 2.7V$  to  $3.6V$  (MAX1363),  $V_{DD} = 4.5V$  to  $5.5V$  (MAX1364),  $V_{REF} = 2.048V$  (MAX1363),  $V_{REF} = 4.096V$  (MAX1364),  $C_{REF} = 0.1\mu F$ ,  $f_{SCL} = 1.7MHz$ ,  $T_A = T_{MIN}$  to  $T_{MAX}$ , unless otherwise noted. Typical values are at  $T_A = +25^\circ C$ .)

PARAMETER	SYMBOL	CONDITIONS		MIN	TYP	MAX	UNITS
Supply Current	$I_{DD}$	MAX1363	$f_{SAMPLE} = 133ksps$ , monitor mode (Note 10)	Internal reference	660	1600	$\mu A$
				External reference	436	1350	
			$f_{SAMPLE} = 94.4ksps$ , external clock	Internal reference	900	1150	
				External reference	670	900	
			$f_{SAMPLE} = 40ksps$ , internal clock	Internal reference	530		
				External reference	230		
		$f_{SAMPLE} = 10ksps$ , internal clock	Internal reference	380			
			External reference	60			
		MAX1364	$f_{SAMPLE} = 1ksps$ , internal clock	Internal reference	330		
				External reference	6		
			$f_{SAMPLE} = 133ksps$ , monitor mode (Note10)	Internal reference	660	1600	
				External reference	436	1350	
			$f_{SAMPLE} = 94.4ksps$ , external clock	Internal reference	900	1150	
				External reference	670	900	
$f_{SAMPLE} = 40ksps$ , internal clock	Internal reference	530					
	External reference	230					
$f_{SAMPLE} = 10ksps$ , internal clock	Internal reference	380					
	External reference	60					
$f_{SAMPLE} = 1ksps$ , internal clock	Internal reference	330					
	External reference	6					
Shutdown Current		Internal reference on		333		$\mu A$	
		Internal reference off		0.5	10		
Power-Supply Rejection Ratio	PSRR	Full-scale input (Note 11)		$\pm 0.01$	$\pm 0.5$	LSB/V	
<b>TIMING CHARACTERISTICS FOR FAST MODE (Figures 1a, 2)</b>							
Serial Clock Frequency	$f_{SCL}$				400		kHz
Bus Free Time Between a STOP (P) and a START (S) Condition	$t_{BUF}$			1.3			$\mu s$

## 4-Channel, 12-Bit System Monitors with Programmable Trip Window and SMBus Alert Response

### ELECTRICAL CHARACTERISTICS (continued)

( $V_{DD} = 2.7V$  to  $3.6V$  (MAX1363),  $V_{DD} = 4.5V$  to  $5.5V$  (MAX1364),  $V_{REF} = 2.048V$  (MAX1363),  $V_{REF} = 4.096V$  (MAX1364),  $C_{REF} = 0.1\mu F$ ,  $f_{SCL} = 1.7MHz$ ,  $T_A = T_{MIN}$  to  $T_{MAX}$ , unless otherwise noted. Typical values are at  $T_A = +25^\circ C$ .)

PARAMETER	SYMBOL	CONDITIONS	MIN	TYP	MAX	UNITS
Hold Time for START (S) Condition	$t_{HD, STA}$		0.6			$\mu s$
Low Period of the SCL Clock	$t_{LOW}$		1.3			$\mu s$
High Period of the SCL Clock	$t_{HIGH}$		0.6			$\mu s$
Setup Time for a Repeated START Condition (Sr)	$t_{SU, STA}$		0.6			$\mu s$
Data Hold Time	$t_{HD, DAT}$		0		900	ns
Data Setup Time	$t_{SU, DAT}$		100			ns
Rise Time of Both SDA and SCL Signals, Receiving	$t_R$	Measured from $0.3V_{DD}$ to $0.7V_{DD}$	0		300	ns
Fall Time of SDA Transmitting	$t_F$	Measured from $0.3V_{DD}$ to $0.7V_{DD}$	0		300	ns
Setup Time for STOP (P) Condition	$t_{SU, STO}$		0.6			$\mu s$
Capacitive Load for Each Bus Line	$C_B$				400	pF
Pulse Width of Spike Suppressed					50	ns
<b>TIMING CHARACTERISTICS FOR HIGH-SPEED MODE (<math>C_B = 400pF</math>, Figures 1a, 2) (Note 12)</b>						
Serial Clock Frequency	$f_{SCLH}$	(Note 13)			1.7	MHz
Hold Time, Repeated START Condition (Sr)	$t_{HD, STA}$		160			ns
Low Period of the SCL Clock	$t_{LOW}$	(Note 13)	320			ns
High Period of the SCL Clock	$t_{HIGH}$		120			ns
Setup Time for a Repeated START Condition (Sr)	$t_{SU, STA}$		160			ns
Data Hold Time	$t_{HD, DAT}$	(Note 14)	0		150	ns
Data Setup Time	$t_{SU, DAT}$		10			ns
Rise Time of SCL Signal, Current Source Enabled	$t_{RCL}$	Measured from $0.3V_{DD}$ to $0.7V_{DD}$	20		80	ns
Rise Time of SCL Signal After Acknowledge Bit	$t_{RCL1}$	Measured from $0.3V_{DD}$ to $0.7V_{DD}$	20		160	ns
Fall Time of SCL Signal	$t_{FCL}$	Measured from $0.3V_{DD}$ to $0.7V_{DD}$	20		80	ns
Rise Time of SDA Signal	$t_{RDA}$	Measured from $0.3V_{DD}$ to $0.7V_{DD}$	20		160	ns
Fall Time of SDA Signal	$t_{FDA}$	Measured from $0.3V_{DD}$ to $0.7V_{DD}$	20		160	ns
Setup Time for STOP (P) Condition	$t_{SU, STO}$		160			ns
Capacitive Load for Each Bus Line	$C_B$	(Notes 13, 14)			400	pF
Pulse Width of Spike Suppressed			0		10	ns

# 4-Channel, 12-Bit System Monitors with Programmable Trip Window and SMBus Alert Response

## ELECTRICAL CHARACTERISTICS (continued)

( $V_{DD} = 2.7V$  to  $3.6V$  (MAX1363),  $V_{DD} = 4.5V$  to  $5.5V$  (MAX1364),  $V_{REF} = 2.048V$  (MAX1363),  $V_{REF} = 4.096V$  (MAX1364),  $C_{REF} = 0.1\mu F$ ,  $f_{SCL} = 1.7MHz$ ,  $T_A = T_{MIN}$  to  $T_{MAX}$ , unless otherwise noted. Typical values are at  $T_A = +25^\circ C$ .)

**Note 1:** Devices configured for unipolar single-ended inputs.

**Note 2:** Relative accuracy is the deviation of the analog value at any code from its theoretical value after the gain and offset have been calibrated.

**Note 3:** Offset nulled.

**Note 4:** Conversion time is defined as the number of clock cycles needed for conversion multiplied by the clock period. Conversion time does not include acquisition time. SCL is the conversion clock in the external clock mode.

**Note 5:** The throughput rate of the I<sup>2</sup>C bus is limited to 94.4ksp/s. The MAX1363/MAX1364 can perform conversions up to 133ksp/s in monitor mode when not reading back results on the I<sup>2</sup>C bus.

**Note 6:** A filter on the SDA and SCL inputs suppresses noise spikes and delays the sampling instant.

**Note 7:** The absolute input-voltage range for the analog inputs (AIN0–AIN3) is from GND to  $V_{DD}$ .

**Note 8:** When the internal reference is configured to be available at AIN3/REF (SEL[2:1] = 11), decouple AIN3/REF to GND with a  $0.01\mu F$  capacitor.

**Note 9:** ADC performance is limited by the converter's noise floor, typically  $300\mu V_{P-P}$ .

**Note 10:** Maximum conversion throughput in internal clock mode when the data is not clocked out.

**Note 11:** For the MAX1363, PSRR is measured as

$$\frac{\left[ V_{FS}(3.6V) - V_{FS}(2.7V) \right] \times \frac{2^N - 1}{V_{REF}}}{(3.6V - 2.7V)}$$

and for the MAX1364, PSRR is measured as

$$\frac{\left[ V_{FS}(5.5V) - V_{FS}(4.5V) \right] \times \frac{2^N - 1}{V_{REF}}}{(5.5V - 4.5V)}$$

**Note 12:**  $C_B$  = total capacitance of one bus line in pF.

**Note 13:**  $f_{SCLH}$  must meet the minimum clock low time plus the rise/fall times.

**Note 14:** A master device must provide a data hold time for SDA (referred to  $V_{IH}$  of SCL) to bridge the undefined region of SCL's falling edge.

## Typical Operating Characteristics

( $V_{DD} = 3.3V$  (MAX1363),  $V_{DD} = 5V$  (MAX1364),  $f_{SCL} = 1.7MHz$ , external clock,  $f_{SAMPLE} = 94.4ksp/s$ , single-ended, unipolar,  $T_A = +25^\circ C$ , unless otherwise noted.)

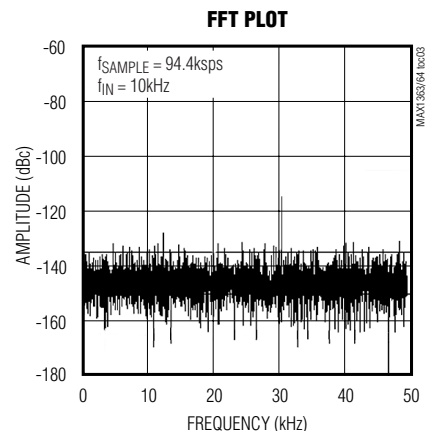
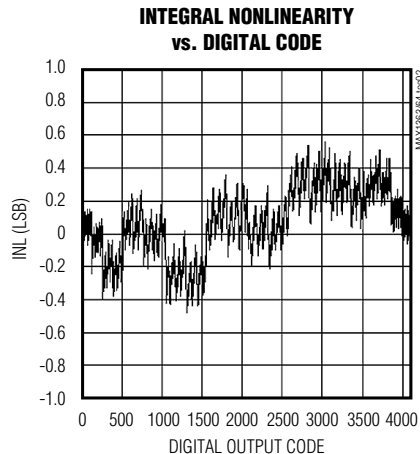
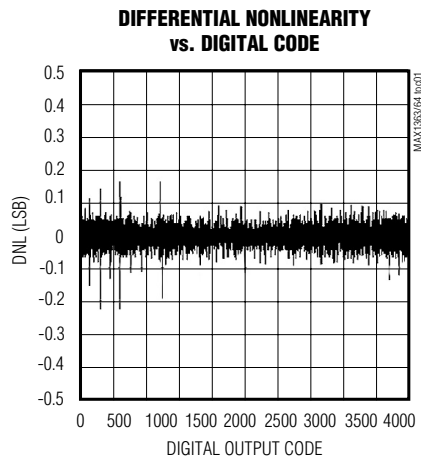

# 4-Channel, 12-Bit System Monitors with Programmable Trip Window and SMBus Alert Response

MAX1363/MAX1364

## Typical Operating Characteristics (continued)

( $V_{DD} = 3.3V$  (MAX1363),  $V_{DD} = 5V$  (MAX1364),  $f_{SCL} = 1.7MHz$ , external clock,  $f_{SAMPLE} = 94.4ksp/s$ , single-ended, unipolar,  $T_A = +25^\circ C$ , unless otherwise noted.)

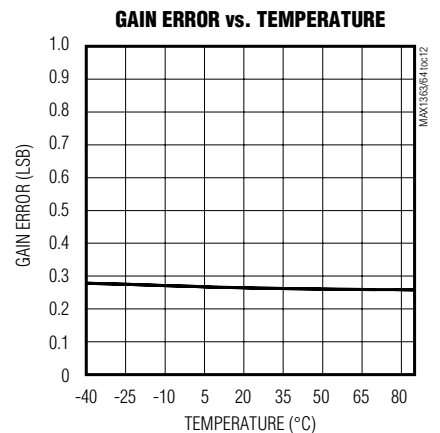
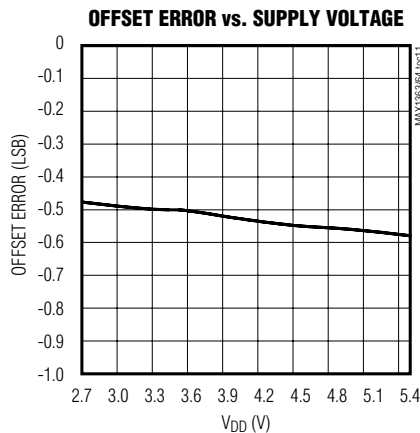
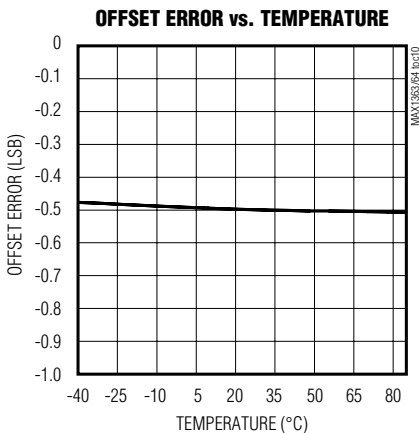
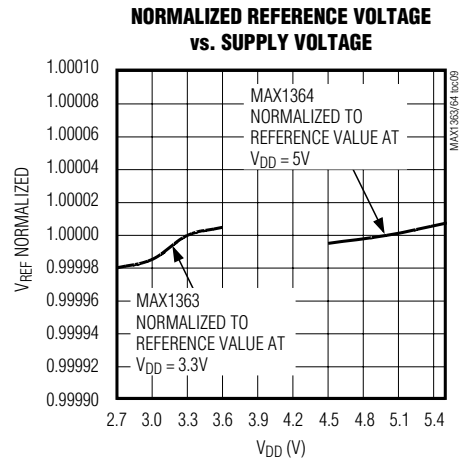
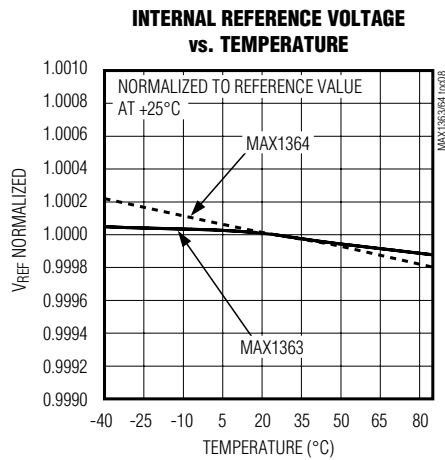
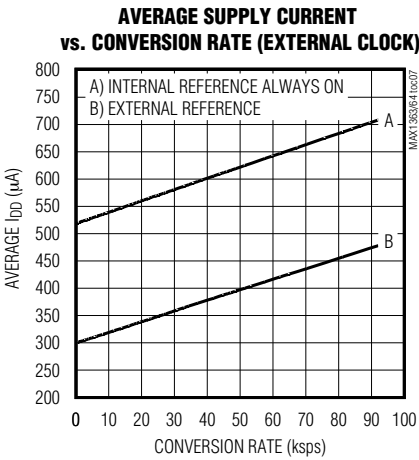
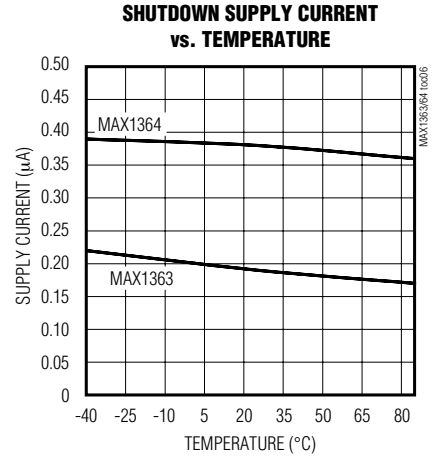
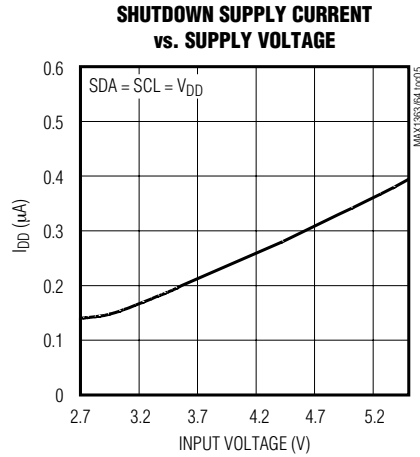
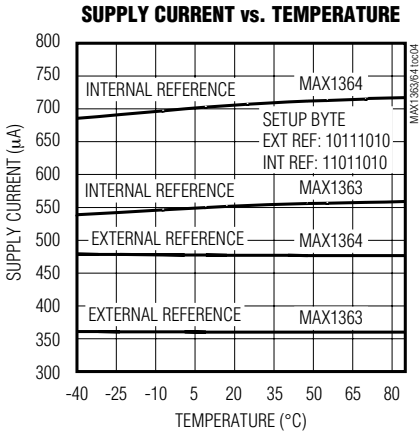

# 4-Channel, 12-Bit System Monitors with Programmable Trip Window and SMBus Alert Response

## Typical Operating Characteristics (continued)

( $V_{DD} = 3.3V$  (MAX1363),  $V_{DD} = 5V$  (MAX1364),  $f_{SCL} = 1.7MHz$ , external clock,  $f_{SAMPLE} = 94.4ksp/s$ , single-ended, unipolar,  $T_A = +25^\circ C$ , unless otherwise noted.)

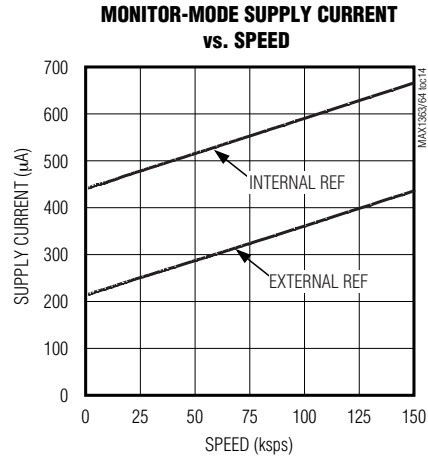
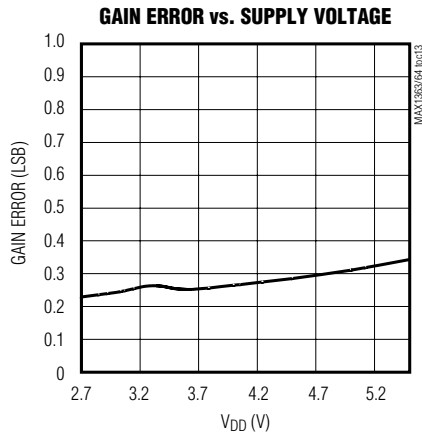

## Pin Description

PIN	NAME	FUNCTION
1	AIN0	Analog Input
2	AIN1	Analog Input
3	AIN2	Analog Input
4	AIN3/VREF	Analog Input or Reference Input or Output. See Table 3.
5	A0	I <sup>2</sup> C Address Select Input. Connect to V <sub>DD</sub> or GND. See Table 1.
6	$\overline{INT}$	Active-Low, Open-Drain Interrupt Output
7	SCL	I <sup>2</sup> C Clock Input
8	SDA	I <sup>2</sup> C Data Input/Output
9	GND	Ground
10	V <sub>DD</sub>	Positive Supply Voltage. Bypass V <sub>DD</sub> to GND with a 0.1µF capacitor.

## Functional Diagram

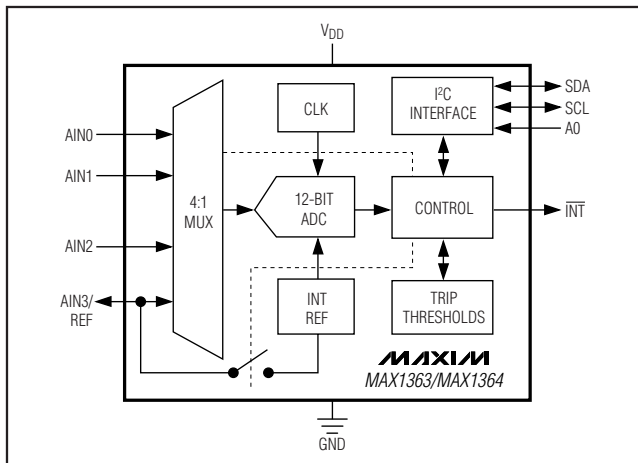

# 4-Channel, 12-Bit System Monitors with Programmable Trip Window and SMBus Alert Response

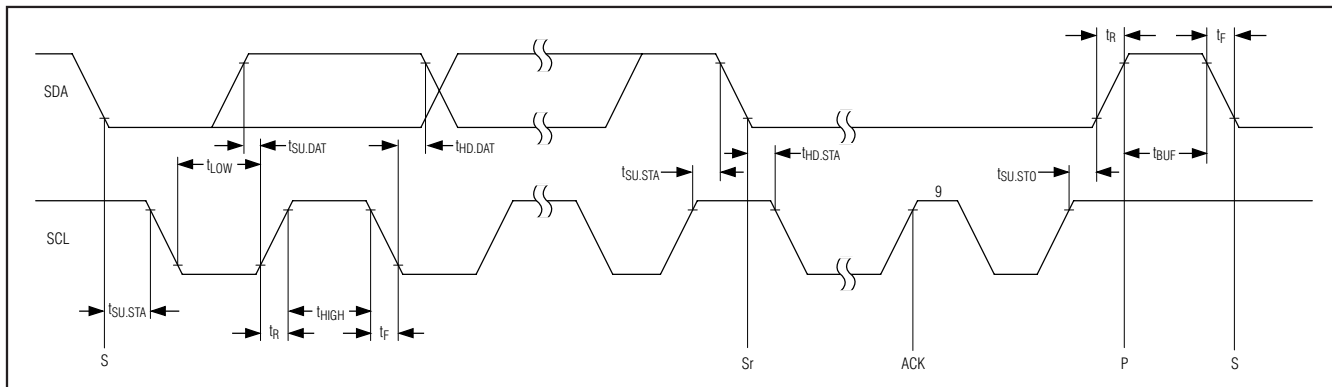

Figure 1a. F/S-Mode 2-Wire Serial-Interface Timing

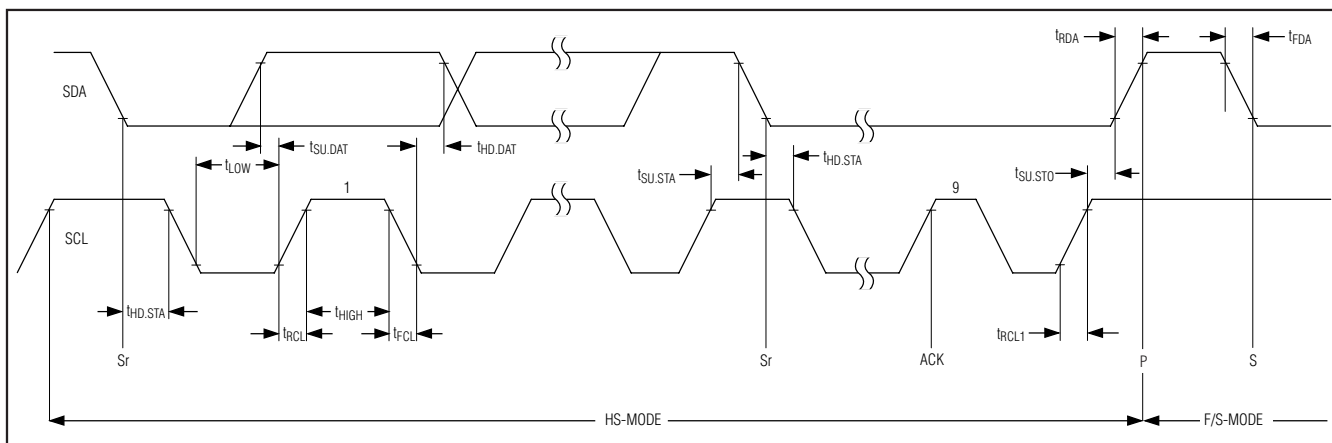

Figure 1b. HS-Mode 2-Wire Serial-Interface Timing

## Detailed Description

The MAX1363/MAX1364 4-channel ADCs use successive-approximation conversion techniques and fully differential input track/hold (T/H) circuitry to capture and convert analog signals to a serial 12-bit digital output. The MAX1363/MAX1364 feature a monitor mode with programmable trip thresholds and window comparator. The monitor function asserts an interrupt when any channel violates the programmed upper or lower thresholds. SMBus alert response allows the host microcontroller ( $\mu\text{C}$ ) to quickly identify which device caused the interrupt. A programmable delay between monitoring intervals lowers power consumption at lower monitor rates.

The MAX1363/MAX1364 integrate an internal voltage reference and clock. The software configures the analog inputs for unipolar/bipolar and single-ended/fully differential operation. Integrated first-in/first-out (FIFO) allows conversion of all channels, or eight conversions

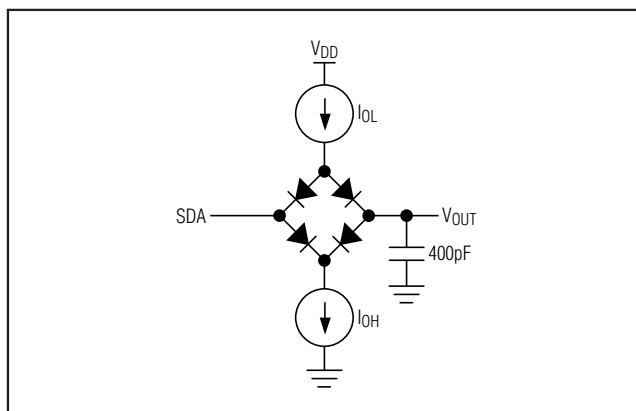

Figure 2. Load Circuits

on a selected channel to reduce interface overhead. An I<sup>2</sup>C-compatible serial interface complies with standard, fast, and high-speed (1.7MHz) modes.

# 4-Channel, 12-Bit System Monitors with Programmable Trip Window and SMBus Alert Response

### Power Supply

The MAX1363 (2.7V to 3.6V) and MAX1364 (4.5V to 5.5V) operate from a single supply and consume 670μA (typ) at sampling rates up to 94.4ksps and 436μA in monitor mode at 133ksps. The MAX1363 features a 2.048V internal reference, and the MAX1364 features a 4.096V internal reference. All devices can be configured for use with an external reference from 1V to V<sub>DD</sub>. Bypass V<sub>DD</sub> to GND using a 0.1μF or greater ceramic capacitor for best performance.

### Analog-Input and Track/Hold

The MAX1363/MAX1364 analog-input architecture contains an analog-input multiplexer (mux), fully differential T/H, comparator, and a fully differential switched capacitive digital-to-analog converter (DAC). Figure 3 shows the equivalent input circuit for the MAX1363/MAX1364.

In single-ended mode, the analog-input mux connects C<sub>T/H</sub> between the analog input selected by CS[3:0] and GND (see the *Configuration/Setup Bytes (Write Cycle)* section). In differential mode, the analog-input mux connects C<sub>T/H</sub> to the plus and minus analog inputs selected by CS[3:0].

During the acquisition interval, the T/H switches are in the track position, and C<sub>T/H</sub> charges to the analog-input signal. At the end of the acquisition interval, the T/H switches move to the hold position, retaining the charge on C<sub>T/H</sub> as a stable sample of the input signal.

During the conversion, a switched capacitive DAC adjusts to restore the comparator input voltage to 0V within the limits of 12-bit resolution. This action requires

12 conversion clock cycles and is equivalent to transferring a charge of 11pF × (V<sub>IN+</sub> - V<sub>IN-</sub>) from C<sub>T/H</sub> to the binary-weighted capacitive DAC, forming a digital representation of the analog-input signal.

Use a low source impedance to ensure an accurate sample. A source impedance of up to 1.5kΩ does not significantly degrade sampling accuracy. For larger source impedances, connect a 100pF capacitor from the analog input to GND or buffer the input.

In internal clock mode, the T/H circuitry enters track mode on the eighth rising clock edge of the address byte (see the *Slave Address* section). The T/H circuitry enters hold mode on the falling clock edge of the acknowledge bit of the address byte (the ninth clock pulse). The conversions are then internally clocked, during which time the MAX1363/MAX1364 hold SCL low.

In external clock mode, the T/H circuitry enters track mode after a valid address on the rising edge of the clock during the read bit (R/W = 1). Hold mode is entered on the rising edge of the second clock pulse during the shifting out of the 1st byte of the result. The next 12 clock cycles perform the conversions.

The time required for the T/H circuitry to acquire an input signal is a function of the input sample capacitance. If the analog-input source impedance is high, the acquisition time constant lengthens and more time must be allowed between conversions. The acquisition time (t<sub>ACQ</sub>) is the minimum time needed for the signal to be acquired. It is calculated by:

$$t_{ACQ} \geq 9 \times (R_{SOURCE} + R_{IN}) \times C_{IN}$$

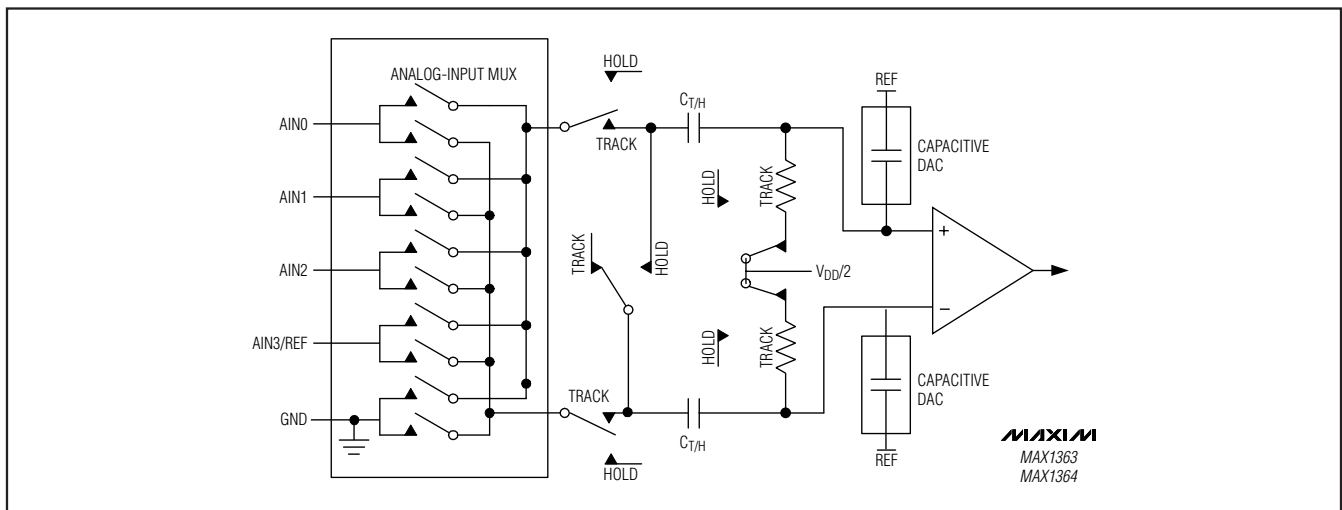

Figure 3. Equivalent Input Circuit

## 4-Channel, 12-Bit System Monitors with Programmable Trip Window and SMBus Alert Response

where  $R_{SOURCE}$  is the analog-input source impedance,  $R_{IN} = 2.5k\Omega$ , and  $C_{IN} = 22pF$ . For internal clock mode,  $t_{ACQ} = 1.5 / f_{SCL}$ , and for external clock mode  $t_{ACQ} = 2 / f_{SCL}$ .

### Analog-Input Bandwidth

The MAX1363/MAX1364 feature input-tracking circuitry with a 5MHz small-signal bandwidth. The 5MHz input bandwidth makes it possible to digitize high-speed transient events and measure periodic signals with bandwidths exceeding the ADC's sampling rate by using undersampling techniques. To avoid high-frequency signals from aliasing into the frequency band of interest, use anti-aliasing filtering.

### Analog-Input Range and Protection

Internal protection diodes clamp the analog inputs to  $V_{DD}$  and GND. These diodes allow the analog inputs to swing from  $(GND - 0.3V)$  to  $(V_{DD} + 0.3V)$  without causing damage to the device. For accurate conversions, the inputs must remain within 50mV below GND or above  $V_{DD}$ .

### Single-Ended/Differential Input

The  $SE/\overline{DIF}$  of the configuration byte configures the MAX1363/MAX1364 analog-input circuitry for single-ended or differential input. In single-ended mode ( $SE/\overline{DIF} = 1$ ), the digital conversion results are the difference between the analog input selected by  $CS[3:0]$  and GND. In differential mode ( $SE/\overline{DIF} = 0$ ), the digital conversion results are the difference between the plus and the minus analog inputs selected by  $CS[3:0]$  (see Tables 5 and 6).

### Unipolar/Bipolar

Unipolar mode sets the differential input range from 0 to  $V_{REF}$ . A negative differential analog input in unipolar mode causes the digital output code to be zero. Selecting bipolar mode sets the differential input range to  $\pm V_{REF} / 2$ . The digital output code is binary in unipolar mode and two's complement in bipolar mode. (See the *Transfer Functions* section.)

In single-ended mode the MAX1363/MAX1364 always operate in unipolar mode. The analog inputs are internally referenced to GND with a full-scale input range from 0 to  $V_{REF}$  (Table 7).

### Reference

$SEL[2:0]$  of the setup byte controls the reference and the AIN3/REF configuration. When AIN3/REF is configured as a reference input or reference output ( $SEL1 = 1$ ), differential conversions on AIN3/REF appear as if AIN3/REF is connected to GND. A single-ended conversion in scan mode on AIN3/REF is ignored by an internal limiter that sets the highest available channel at AIN2.

### Internal Reference

The internal reference is 2.048V for the MAX1363 and 4.096V for the MAX1364.  $SEL1$  of the setup byte controls whether AIN3/REF is used for an analog input or a reference. Decouple AIN3/REF to GND with a 0.1 $\mu$ F capacitor and a 2k $\Omega$  resistor in series with the capacitor. When AIN3/REF is configured as an internal reference output ( $SEL[1:0] = 11$ ). See the *Typical Operating Circuit*. Once powered up, the reference remains on until reconfigured. Do not use the reference to supply current for external circuitry.

### External Reference

The external reference ranges from 1V to  $V_{DD}$ . For maximum conversion accuracy, the reference must deliver 40 $\mu$ A and have an impedance of 500 $\Omega$  or less. For noisy or high-output-impedance references, insert a 0.1 $\mu$ F bypass capacitor to GND as close to AIN3/REF as possible.

### Clock Modes

The clock mode determines the conversion clock and the data acquisition and conversion time. The clock mode also affects the scan mode. The state of the setup byte's  $\overline{INT}/EXT$  clock bit determines the clock mode. At power-up, the MAX1363/MAX1364 default to internal clock mode ( $\overline{INT}/EXT$  clock = 0).

### Internal Clock

See the *Configuration/Setup Bytes (Write Cycle)* section. In internal clock mode ( $CLK = 0$ ), the MAX1363/MAX1364 use an internal oscillator for the conversion clock. The MAX1363/MAX1364 begin tracking the analog input after a valid address on the eighth rising edge of the clock. On the falling edge of the ninth clock, the analog signal is acquired and the conversion begins. While converting, the MAX1363/MAX1364 hold SCL low (clock stretching). After completing the conversion, the results are stored in internal memory. For scan-mode configurations with multiple conversions (see the *Scan Modes* section), all conversions happen in succession with each additional result stored in memory. Once all conversions are complete, the MAX1363/MAX1364 release SCL, allowing it to go high. The master can now clock the results out in the same order as the scan conversion.

The converted results are read back in a FIFO sequence. If AIN3/REF is configured as a reference input or output, AIN3/REF is excluded from multichannel scan. If reading continues past the final result stored in memory, the pointer wraps around and points to the first result. Only the current conversion results are read from memory. The MAX1363/MAX1364 must be addressed with a read command to obtain new conversion results.

## 4-Channel, 12-Bit System Monitors with Programmable Trip Window and SMBus Alert Response

### External Clock

See the *Configuration/Setup Bytes (Write Cycle)* section. When configured for external clock mode (CLK = 1), the MAX1363/MAX1364 use SCL as the conversion clock. In external clock mode, the MAX1363/MAX1364 begin tracking the analog input on the ninth rising clock edge of a valid slave address byte. Two SCL clock cycles later, the analog signal is acquired and the conversion begins. Unlike internal clock mode, converted data is clocked out immediately in the format described in the *Reading a Conversion (Read Cycle)* section.

The device continuously converts input channels dictated by the scan mode until given a not acknowledge (NACK). There is no need to readdress the device with a read command to obtain new conversion results.

The conversion must complete in 1ms or droop on the T/H capacitor degrades conversion results. Use internal clock mode if the SCL clock period exceeds 60 $\mu$ s.

Use external clock mode for conversion rates from 40ksps to 94.4ksps. Use internal clock mode for conversions under 40ksps. Internal clock mode consumes less power. Monitor mode always uses internal clock mode.

### Applications Section

#### Power-On Reset

The configuration and setup registers default to a single-ended, unipolar, single-channel conversion on AIN0 using the internal clock with V<sub>DD</sub> as the reference and AIN3/REF configured as an analog input. The memory contents are unknown at power-up (see the *Software Description* section).

#### I<sup>2</sup>C-Compatible 2-Wire Serial Interface

The MAX1363/MAX1364 use an I<sup>2</sup>C-compatible 2-wire interface consisting of a serial data line (SDA) and serial clock line (SCL). SDA and SCL facilitate bidirectional communication between the MAX1363/MAX1364 and the master at rates up to 1.7MHz. The master (typically a  $\mu$ C) initiates data transfer on the bus and generates the SCL signal to permit data transfer. The MAX1363/MAX1364 behave as I<sup>2</sup>C slave devices that transfer and receive data.

SDA and SCL must be pulled high for proper I<sup>2</sup>C operation. This is typically done with pullup resistors (750 $\Omega$  or greater). Series resistors (R<sub>S</sub>) are optional (see the *Typical Operating Circuit* section). The resistors protect the input architecture of the MAX1363/MAX1364 from high voltage spikes on the bus lines and minimize crosstalk and undershoot of the bus signals.

One bit transfers during each SCL clock cycle. A minimum of nine clock cycles is required to transfer a byte

in or out of the MAX1363/MAX1364 (8 bits and an ACK/NACK). The data on SDA must remain stable during the high period of the SCL clock pulse. Changes in SDA while SCL is stable and high are considered control signals (see the *START and STOP Conditions* section). Both SDA and SCL remain high when the bus is not busy.

#### START and STOP Conditions

The master initiates a transmission with a START condition (S), which is a high-to-low transition on SDA while SCL is high. The master terminates a transmission with a STOP condition (P), which is a low-to-high transition on SDA while SCL is high (Figure 4). A repeated START condition (Sr) can be used in place of a STOP condition to leave the bus active and the mode unchanged (see the *HS I<sup>2</sup>C Mode* section).

#### Acknowledge and Not-Acknowledge Conditions

Data transfers are framed with an acknowledge bit (ACK) or a not-acknowledge bit (NACK). Both the master and the MAX1363/MAX1364 (slave) generate acknowledge bits. To generate an acknowledge, the receiving device must pull SDA low before the rising edge of the acknowledge-related clock pulse (ninth pulse) and keep it low during the high period of the clock pulse (Figure 5).

To generate a not-acknowledge condition, the receiver allows SDA to be pulled high before the rising edge of the acknowledge-related clock pulse, and leaves SDA high during the high period of the clock pulse. Monitoring the acknowledge bits allows for detection of

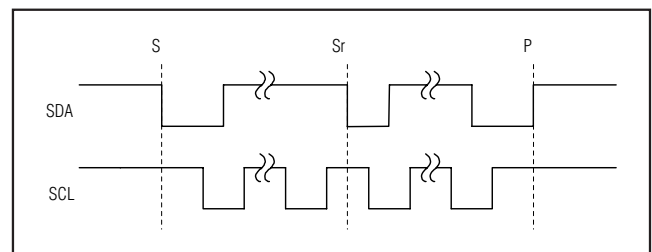

Figure 4. START and STOP Conditions

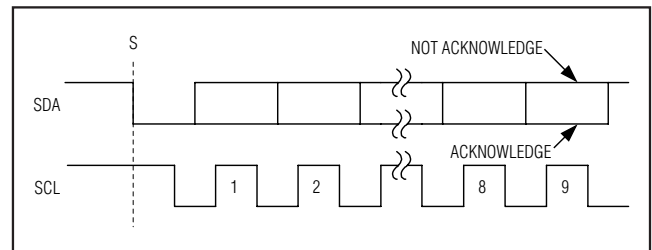

Figure 5. Acknowledge Bits

# 4-Channel, 12-Bit System Monitors with Programmable Trip Window and SMBus Alert Response

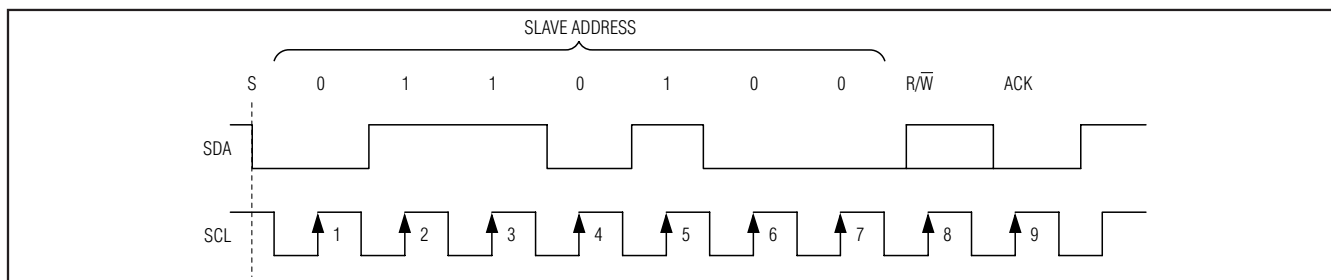

Figure 6. MAX1363/MAX1364 Slave Address Byte

**Table 1. I<sup>2</sup>C Slave Selection Table**

A0 STATE	SUFFIX	ADDRESS
Low	EUB	0110100
High	EUB	0110101
Low	MEUB	0110110
High	MEUB	0110111

unsuccessful data transfers. An unsuccessful data transfer happens if a receiving device is busy or if a system fault has occurred. In the event of an unsuccessful data transfer, the bus master reattempts communication at a later time.

### Slave Address

The MAX1363/MAX1364 have a 7-bit I<sup>2</sup>C slave address. The slave address is selected using A0. The MAX1363/MAX1364 (EUB, MEUB, and LEUB) have three base address options, allowing up to six devices concurrently per I<sup>2</sup>C bus (see Table 1).

The MAX1363/MAX1364 continuously wait for a START condition followed by its slave address. When the device recognizes its slave address, it is ready to accept or send data depending on the R/W bit (Figure 6).

### HS I<sup>2</sup>C Mode

At power-up, the MAX1363/MAX1364 bus timing is set for fast mode (F/S mode, up to 400kHz I<sup>2</sup>C clock), which limits the conversion rate to approximately 22ksps. Switch to high-speed mode (HS mode, up to 1.7MHz I<sup>2</sup>C clock) to achieve conversion rates up to 94.4ksps. The MAX1363/MAX1364 convert up to 133ksps in monitor mode, regardless of I<sup>2</sup>C mode. If conversion results are unread, I<sup>2</sup>C bandwidth limitations do not apply (see the *Monitor Mode* section).

Select HS mode by addressing all devices on the bus with the HS-mode master code 0000 1XXX (X = don't care). After successfully receiving the HS-mode master code, the MAX1363/MAX1364 issue a NACK, allowing SDA to be pulled high for one clock cycle (Figure 7).

After the NACK, the MAX1363/MAX1364 operate in HS mode. Send a repeated START (Sr) followed by a slave address to initiate HS-mode communication. If the master generates a STOP condition, the MAX1363/MAX1364 return to F/S mode. Use a repeated START condition (Sr) in place of a STOP condition to leave the bus active and the mode unchanged.

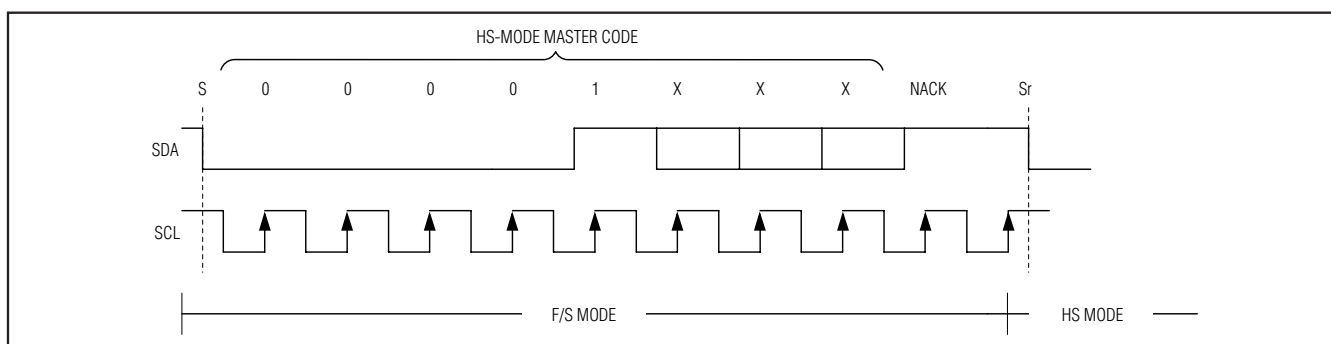

Figure 7. F/S-Mode to HS-Mode Transfer

# 4-Channel, 12-Bit System Monitors with Programmable Trip Window and SMBus Alert Response

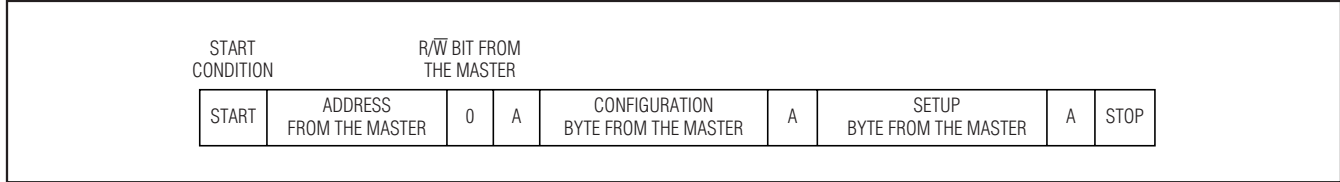

Figure 8. Example of Writing Setup and Control Bytes

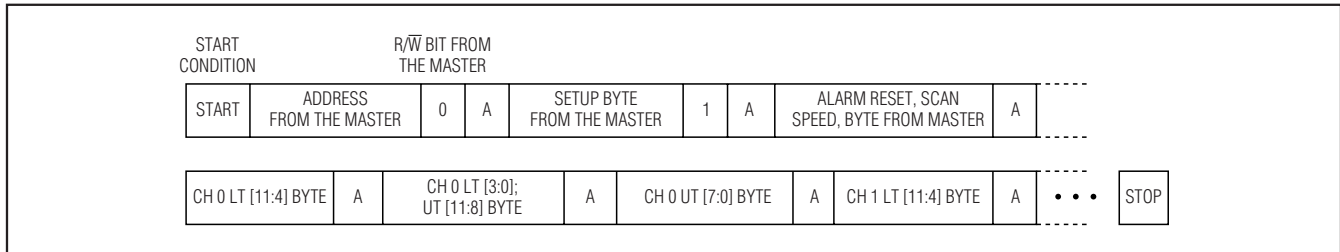

Figure 9. Example of Extended Setup Byte Writing

**Table 2. Configuration Byte Format\***

BIT	NAME	DESCRIPTION
7(MSB)	CONFIG	The configuration byte always starts with 0.
6	SCAN1	SCAN1, SCAN0 = [0,0], scans from channel 0 to the upper channel chosen by CS1, CS0. SCAN1, SCAN0 = [0,1], converts a single channel chosen by CS1, CS0 eight times.
5	SCAN0	SCAN1, SCAN0 = [1,0] monitor mode monitors from channel 0 to the upper channel chosen by CS1, CS0. SCAN1, SCAN0 = [1,1], single channel conversion for the channel is chosen by CS0, CS1.
4	CS3	CS3, CS2 = [1,1] enables readback of monitor-mode setup data.
3	CS2	
2	CS1	
1	CS0	Selects the upper limit of the channel range used for the conversion sequence in scan modes SCAN = [0,0] and monitor modes SCAN = [1,0]. Selects the conversion channel when SCAN = [0,1] or when SCAN = [1,1]. (Tables 5 and 6)
0	SE/DIF	1 = single-ended inputs. 0 = differential inputs. AIN0 and AIN1 form the first differential pair and AIN2 and AIN3 form the second differential pair. (See Tables 4 and 5.) Selects single-ended or differential conversions. In single-ended mode, input-signal voltages are referenced to GND. In differential mode, the voltage difference between two channels is measured. When single-ended mode is used, the MAX1363/MAX1364 perform unipolar conversions regardless of the UNI/BIP bit in the setup byte. (Table 7)

\*Power-on defaults: 0x01

# 4-Channel, 12-Bit System Monitors with Programmable Trip Window and SMBus Alert Response

## Software Description

### Configuration/Setup Bytes (Write Cycle)

A write cycle begins with the bus master issuing a START condition followed by 7 address bits and a write bit ( $R/\bar{W} = 0$ ). If the address byte is successfully received, the MAX1363/MAX1364 (slave) issue an ACK. The master then writes to the slave. If the most significant bit (MSB) is 1, the slave recognizes the received byte as the setup byte (Table 4). If the MSB is 0, the slave recognizes that byte as the configuration byte (Table 2). Write to the configuration byte before writing to the setup byte (Figure 8). If enabling  $\overline{\text{RESET}}$  in the setup byte, rewrite the configuration byte after writing the setup byte, since  $\overline{\text{RESET}}$  clears the contents of the configuration byte back to the power-up state.

When the monitor-setup bit of the setup byte is set to 1, writing extends up to 13 bytes to clock in monitor-setup data. Terminate writing monitor-setup data at any time by issuing a STOP or repeated START condition. If the slave receives a byte successfully, it issues an ACK (Figure 9).

**Note:** When operating in HS mode, a STOP condition returns the bus into F/S mode (see the *HS I<sup>2</sup>C Mode* section).

### Automatic Shutdown

AutoShutdown occurs between conversions when the MAX1363/MAX1364 are idle. When operating in external clock mode, issue a STOP, NACK, or repeated START condition to place the devices in idle mode and benefit from automatic shutdown. A STOP condition is not necessary in internal clock mode for automatic shutdown because power-down occurs once all contents are written memory. Shutdown reduces supply current to less than 0.5 $\mu$ A (external reference mode, typ) and 300 $\mu$ A (internal reference mode, typ).

When idle, the MAX1363/MAX1364 continuously wait for a START condition followed by their slave address. Upon reading a valid address byte, the MAX1363/MAX1364 power up. The internal reference requires

10ms to wake up. Therefore, power up the internal reference 10ms prior to conversion or leave the reference continuously powered. Wake-up is transparent when using an external reference or  $V_{DD}$  as the reference.

Automatic shutdown results in dramatic power savings, particularly at slow conversion rates with internal clock. For example, using an external reference at a conversion rate of 10ksps, the average supply current for the MAX1363 is 60 $\mu$ A (typ) and drops to 6 $\mu$ A (typ) at 1ksps. At 0.1ksps, the average supply current is just 1 $\mu$ A. Table 3 shows AIN3/REF configuration and reference power-down state.

### Scan Modes

SCAN1 and SCAN0 of the configuration byte set the scan-mode configuration. When configuring AIN3/REF for reference input or output ( $\text{SEL0} = 1$ ), AIN3/REF is excluded from a multichannel scan. The scanned results write to memory in the same order as the conversion. Start a conversion sequence by initiating a read with the desired scan mode. Read the results from memory in the order they were converted (see the *Reading a Conversion (Read Cycle)* section).

Selecting channel scan mode [0,0] starts converting from channel 0 up to the channel chosen by CS1, CS0.

Selecting channel scan mode [0,1] converts the channel selected by CS1, CS0 eight times and returns eight consecutive results.

Selecting monitor mode [1,0] initiates a continuous conversion scan sequence from channel 0 to the channel selected by CS1, CS0. See the *Monitor Mode* section for more details.

Selecting channel scan mode [1,1] performs a single conversion on the channel selected by CS1, CS0 and returns the result.

### Reading a Conversion (Read Cycle)

Initiate a read cycle to start a conversion sequence and to obtain conversion results. See the *Scan Modes* section for details on the channel-scan sequence. Read

**Table 3. Reference Voltage and AIN3/REF Format**

SEL1	SEL0	INT REF POWER-DOWN	REFERENCE VOLTAGE	AIN3/REF	INTERNAL REFERENCE STATE
0	0	X	$V_{DD}$	Analog input	Always off
0	1	X	External reference	Reference input	Always off
1	0	0	Internal reference	Analog input	Always off
1	0	1	Internal reference	Analog input	Always on
1	1	0	Internal reference	Reference output	Always off
1	1	1	Internal reference	Reference output	Always on

## 4-Channel, 12-Bit System Monitors with Programmable Trip Window and SMBus Alert Response

Table 4. Setup-Byte Format\*

BIT	NAME	DESCRIPTION
7 (MSB)	Setup	Setup byte always starts with 1.
6	REF/AIN SEL1	When [0,0], REF/AIN3 = AIN3, REF = V <sub>DD</sub> . When [0,1], REF/AIN3 = REF, apply external reference to REF.
5	REF/AIN SEL0	When [1,0], REF/AIN3 = AIN3, REF = internal reference. When [1,1], REF/AIN3 = REF, REF = internal reference. (Table 3)
4	INT REF Power Down	1 = internal reference always powered up. 0 = internal reference always powered down. (Table 3)
3	$\overline{\text{INT}}/\text{EXT}$ Clock	0 = internal clock. 1 = external clock (MAX1363/MAX1364 use the SCL clock for conversions).
2	$\overline{\text{UNI}}/\text{BIP}$	0 = unipolar. 1 = bipolar. Selects unipolar or bipolar conversion mode. In unipolar mode, analog signal in 0 to V <sub>REF</sub> range can be converted. In differential bipolar mode, input signal can range from -V <sub>REF</sub> / 2 to +V <sub>REF</sub> / 2. When single-ended mode is chosen, the SE/DIF bit of configuration byte overrides $\overline{\text{UNI}}/\text{BIP}$ , and conversions are performed in unipolar mode.
1	Reset	1 = no action. 0 = resets $\overline{\text{INT}}$ and configuration register. Setup register and channel trip thresholds are unaffected.
0	Monitor Setup	0 = no action. 1 = extends writing up to 13 bytes (104 bits) of alarm reset mask. Scans speed selection and alarm thresholds. See the <i>Configuring Monitor Mode</i> section.

\*Power-on defaults: 0x82

Table 5. Channel Selection in Single-Ended Mode (SE/DIF = 1)

CS1	CS0	CH0	CH1	CH2	CH3
0	0	+			
0	1		+		
1	0			+	
1	1				+

Table 6. Channel Selection in Differential Mode (SE/DIF = 0)

CS1	CS0	CH0	CH1	CH2	CH3
0	0	+	-		
0	1	-	+		
1	0			+	-
1	1			-	+

Table 7. SE/DIF and  $\overline{\text{UNI}}/\text{BIP}$  Table

SE/DIF	$\overline{\text{UNI}}/\text{BIP}$	MODE
0	0	Differential inputs, unipolar
0	1	Differential inputs, bipolar
1	0	Single-ended inputs, unipolar
1	1	Single-ended inputs, unipolar

cycles begin with the bus master issuing a START condition followed by 7 address bits and a read bit (R/W = 1). After successfully receiving the address byte, the MAX1363/MAX1364 (slave) issue an ACK. The master then reads from the slave. (See Figures 10–13.)

The result is transmitted in 2 bytes. The 1st byte consists of a leading 1 followed by a 2-bit binary channel address tag, a 12/10 bit flag (1 for the MAX1363/MAX1364), the first 4 bits of the data result, and the expected ACK from the master. The 2nd byte contains D7–D0. To read the next conversion result, issue an ACK. To stop reading, issue a NACK.

# 4-Channel, 12-Bit System Monitors with Programmable Trip Window and SMBus Alert Response

**Table 8. Data Format**

HIGH	CH1	CH0	12/T0	D11 (MSB)	D10	D9	D8		D7	D6	D5	D4	D3	D2	D1	D0	
1	0/1	0/1	0 = 10b 1 = 12b	0/1	0/1	0/1	0/1	ACK	0/1	0/1	0/1	0/1	0/1	0/1	0/1	0/1	ACK/ NACK

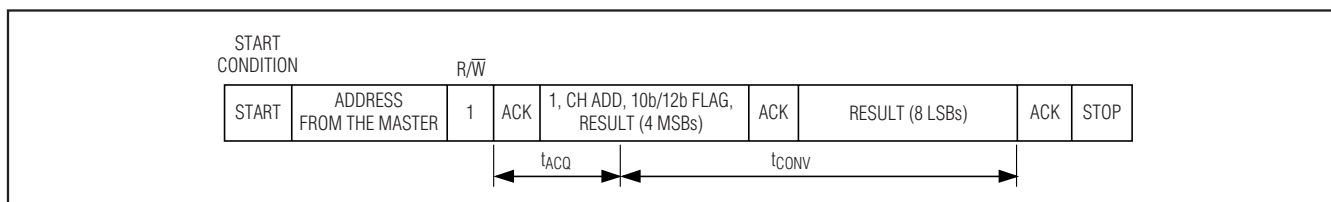

Figure 10. Example of Reading the Conversion Result—External Clock Mode

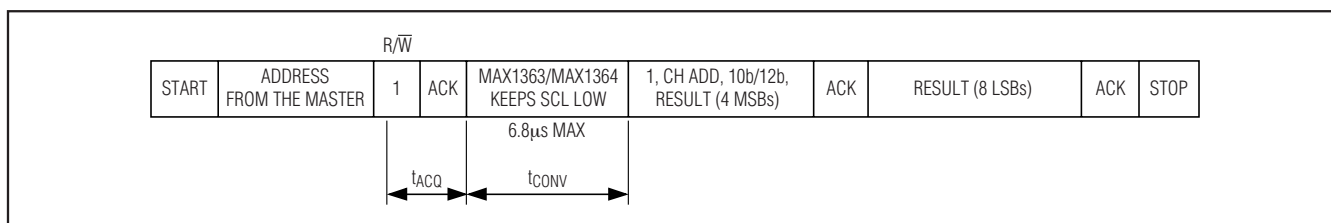

Figure 11. Example of a Single Conversion Using the Internal Clock, SCAN = 1, 1

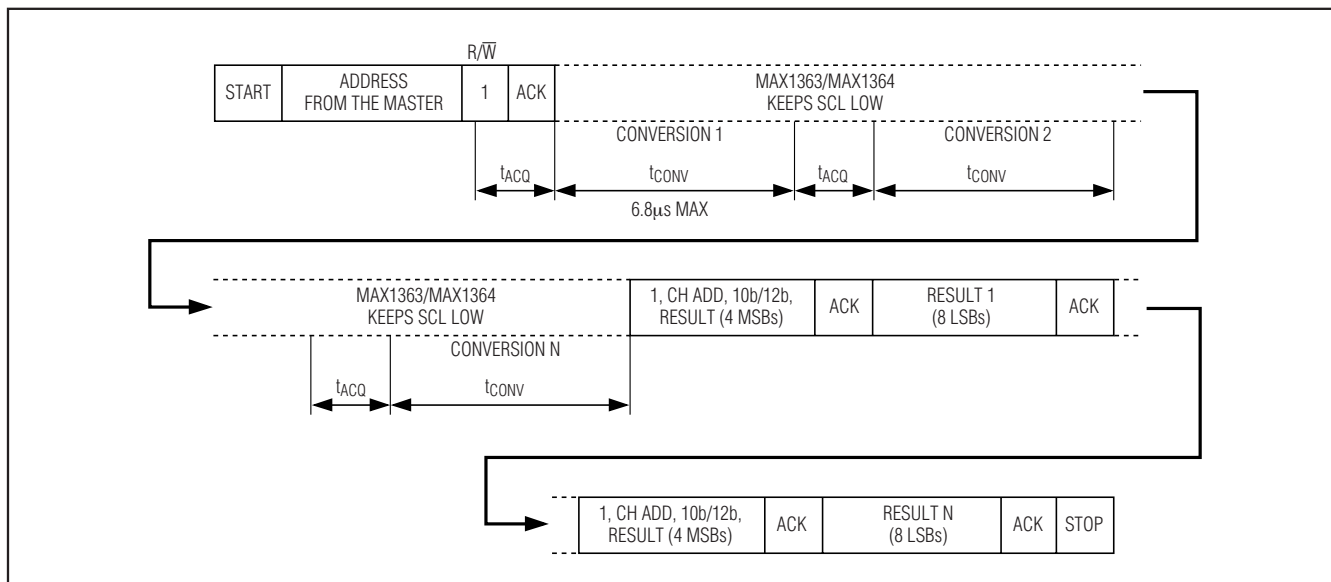

Figure 12. Example of Scan-Mode Conversions Using the Internal Clock, SCAN = 0, 0 and 0, 1

## 4-Channel, 12-Bit System Monitors with Programmable Trip Window and SMBus Alert Response

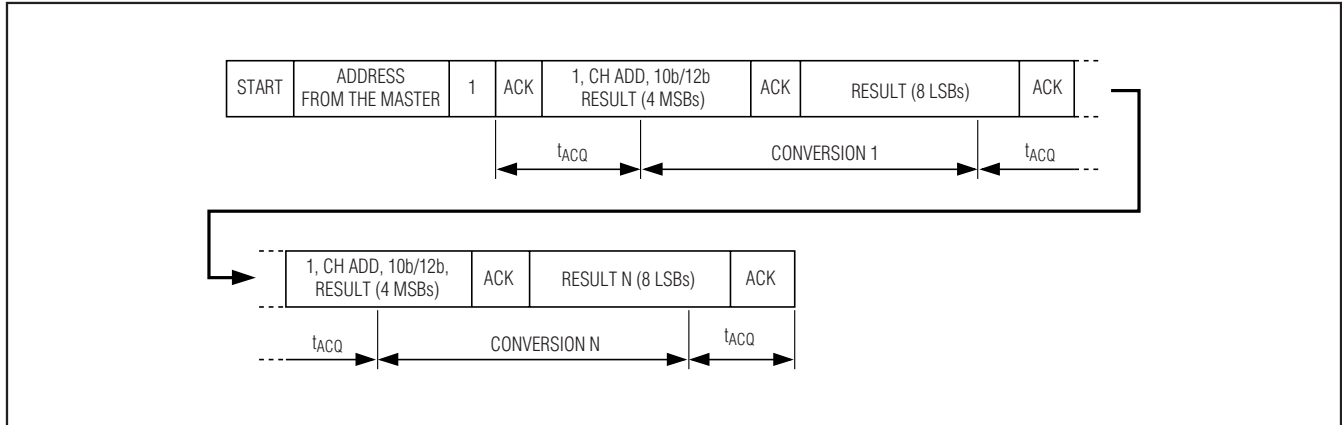

Figure 13. Example of Scan-Mode Conversions Using the External Clock, SCAN = 0,0 and 0,1

When the MAX1363/MAX1364 receive a NACK, they release SDA allowing the master to generate a STOP or a repeated START condition.

### Monitor Mode

#### Monitor-Mode Overview

The MAX1363/MAX1364 automatically monitor up to four input channels. For systems with limited I<sup>2</sup>C bandwidth, monitor mode allows the  $\mu$ C to set a window by programming lower and upper thresholds during initialization, and only intervening if the MAX1363/MAX1364 detect an alarm condition. This allows an interrupt-driven approach as an alternative to continuously polling the ADC with the  $\mu$ C. Monitor mode reduces processor overhead and conserves I<sup>2</sup>C bandwidth.

The following shows an example of events in monitor mode:

- 1) Fault condition(s) detected,  $\overline{\text{INT}}$  asserted.
- 2) Host  $\mu$ C services interrupt and sends SMBus alert to identify the alarming device. The MAX1363/MAX1364 respond with the I<sup>2</sup>C slave address, pending arbitration rules. (See the *SMBus Alert* section.)
- 3) The MAX1363/MAX1364 release the  $\overline{\text{INT}}$ .
- 4) Host  $\mu$ C reads the alarm-status register, latched-fault register, and current-conversion results to determine the alarming channel(s) and course of action.
- 5) Host  $\mu$ C services alarm(s); adjusts system parameters as needed and/or adjusts lower and upper thresholds.
- 6) Host  $\mu$ C resets the alarming channel. See the *Configuring Monitor Mode* section.
- 7) Monitor mode resumes.

- 8) If there is still an active fault, the device asserts  $\overline{\text{INT}}$  again. See step 1.

Writing SCAN1 and SCAN0 bits = [1,0] in the configuration byte activates monitor mode. The MAX1363/MAX1364 scan from channels 0 up to the channel selected by [CS1:CS0] at a rate determined by the scan delay bits. The MAX1363/MAX1364 compare the conversion results with the lower and upper thresholds for each channel. When any conversion exceeds the threshold, the MAX1363/MAX1364 assert an interrupt by pulling  $\overline{\text{INT}}$  low (if enabled). The MAX1363/MAX1364 set the corresponding flag bit in the alarm-status register and write conversion results to the latched-fault register to record the event causing the alarm condition.

$\overline{\text{INT}}$  active state is randomly delayed with respect to the conversion. Depending on the number of channels scanned and the position in the channel scan sequence, the maximum possible delay for asserting  $\overline{\text{INT}}$  is five conversion periods (37.5 $\mu$ s typ, Delay = 0,0,0).

#### Configuring Monitor Mode

To write monitoring setup data, set the monitor-setup bit (bit 0 in setup byte) to 1 to extend writing up to 104 bits (13 bytes) of monitoring setup data. The number of bits written to the MAX1363/MAX1364 depends on whether the part is in single-ended or differential mode and whether the upper channel limit is set by [CS1:CS0] (Table 9).

Terminate writing at any time by using a STOP or repeated START condition. Previous monitoring setup data not overwritten remains valid.

A 1 written to the reset alarm CH\_ clears the alarm, otherwise no action occurs (Table 10). Deassert  $\overline{\text{INT}}$  by

## 4-Channel, 12-Bit System Monitors with Programmable Trip Window and SMBus Alert Response

**Table 9. Monitor-Mode Setup Data Format**

Alarm reset, scan speed, INT_EN, (8 bits)	AIN0 thresholds (24 bits)	AIN1 thresholds (skip if differential mode, or CS1, CS0 < 1) (24 bits)	AIN2 thresholds (skip if CS1, CS0 < 2) (24 bits)	AIN3 thresholds (skip if differential mode, or CS1, CS0 < 3) (24 bits)
---	---------------------------	--	--	--

**Table 10. Alarm Reset, Scan Speed Register, and INT\_EN Data Format**

RESET ALARM CH 0	RESET ALARM CH 1	RESET ALARM CH 2	RESET ALARM CH 3	DELAY 2	DELAY 1	DELAY 0	INT_EN
0/1	0/1	0/1	0/1	0/1	0/1	0/1	0/1

**Table 11. Delay Settings**

DELAY 2	DELAY 1	DELAY 0	MONITOR-MODE CONVERSION RATE (ksps)
0	0	0	133.0*
0	0	1	66.5
0	1	0	33.3
0	1	1	16.6
1	0	0	8.3
1	0	1	4.2
1	1	0	2.0
1	1	1	1.0

\*When using delay = [0,0,0] in internal reference mode and AIN3/REF configured as a REF output, the MAX1363/MAX1364 may exhibit a code-dependent gain error due to insufficient internal reference drive. Gain error caused by this phenomenon is typically less than 1%FSR (0.1 $\mu$ F C<sub>REF</sub>) and increases with a larger C<sub>REF</sub>. Avoid this gain error by using an external reference, V<sub>DD</sub>, as a reference or use an internal reference with AIN3/REF as an analog input (see Table 4). Alternatively, choose delay bits other than [0,0,0] to lower the conversion rate.

clearing all alarms or by initiating an SMBus alert during an alarm condition (see the *SMBus Alert* section).

The Delay 2, Delay 1, Delay 0 bits set the speed of monitoring by changing the delay between conversions. Delay 2, 1, 0 = 000 sets the maximum possible speed; 001 divides the maximum speed by ~2. Increasing delay values further divides the previous speed by two.

INT\_EN controls the open-drain  $\overline{\text{INT}}$  output. Set INT\_EN to 1 to enable the hardware interrupt. Set INT\_EN to 0 to disable the hardware interrupt output. The  $\overline{\text{INT}}$  output tri-states when disabled or when there are no alarms. The master can also poll the alarm status register at any time to check the alarm status.

Repeat clocking channel threshold data up to the channel programmed by CS1 and CS0 (Table 12). For differential input mode, omit odd channels; the lower and upper threshold data applies to channel pairs. There is no need to clock in dummy data for odd (or even) channels (Table 6).

To disable alarming on a specific channel, set the lower threshold to 0x800 and the upper threshold to 0x7FF for bipolar mode, or set the lower threshold to 0x000 and the upper threshold to 0xFFFF for unipolar mode.

**Table 12. Lower and Upper Threshold Data Format**

BYTE	B7	B6	B5	B4	B3	B2	B1	B0	ACKNOWLEDGE
1	LT11 (MSB)	LT10	LT9	LT8	LT7	LT6	LT5	LT4	ACK
2	LT3	LT2	LT1	LT0 (LSB)	UT11 (MSB)	UT10	UT9	UT8	ACK
3	UT7	UT6	UT5	UT4	UT3	UT2	UT1	UT0 (LSB)	ACK

X = Don't care.

ACK = Acknowledge.

## 4-Channel, 12-Bit System Monitors with Programmable Trip Window and SMBus Alert Response

Table 13. Readback-Mode Format

ALARM RESET/SCAN SPEED								AIN0 THRESHOLDS	AIN1 THRESHOLDS (SKIP IF DIFFERENTIAL MODE OR CS1, CS0 < 1)	AIN2 THRESHOLDS (SKIP IF CS1, CS0 < 2)	AIN3 THRESHOLDS (SKIP IF DIFFERENTIAL MODE OR CS1, CS0 < 3)
1	1	1	1	D2	D1	D0	INT	24 bits	24 bits	24 bits	24 bits

Table 14. Reading in Monitor-Mode Data Format

ALARM-STATUS REGISTER	LATCHED-FAULT REGISTER	CURRENT-CONVERSION RESULTS
8 bits	16, 32, 48, or 64 bits	16, 32, 48, or 64 bits

Table 15. Alarm-Status Register

CH0 UP	CH0 LOW	CH1 UP	CH1 LOW	CH2 UP	CH2 LOW	CH3 UP	CH3 LOW
0/1	0/1	0/1	0/1	0/1	0/1	0/1	0/1

0 = Not-alarm condition.

1 = Alarm condition.

Table 16. Latched-Fault and Current-Conversion Register

AIN0	AIN1	AIN2	AIN3
16-bit read	16-bit read	16-bit read	16-bit read

### Readback Mode

Select readback mode by setting CS3, CS2 to [1,1] in the configuration byte. Begin a read operation to start reading back monitor-setup data. Clock out delay bit settings, INT\_EN bit, and the lower and upper thresholds programmed for each channel. Readback mode follows exactly the same format as writing to the monitor-setup data, with the exception of the first 4 alarm-reset bits, which are always 1 (Table 13).

### Reading in Monitor Mode

Reading in monitor mode reads back the alarm-status register, latched-fault register, and current-conversion results as shown in Table 14.

The MAX1363/MAX1364 register pointer loops back to the beginning of the current-conversion result after reading the last conversion result. Stop reading at any time by asserting a STOP condition or NACK.

**Note:** The MAX1363/MAX1364 do not update the current-conversion results register while reading in monitor mode. Monitor mode resumes after a STOP condition or NACK.

### Alarm-Status Register and Latched-Fault Register

The latched-fault register records a snapshot of the alarming channel at the instance that a fault condition is asserted. An alarm-status bit of 1 (Table 15) indicates a fault, and the data in the latched-fault register of the corresponding channel contains the conversion result that caused the alarm to trip. Resetting alarms does not clear the latched-fault register, thus the latched-fault register contains valid data only if an alarm status bit is high for the given channel.

The current-conversion register contains the most recent conversion results. If the user attempts to read past the last result of the current-conversion register, the MAX1363/MAX1364 wraps back to the beginning of the current-conversion result.

The latched-fault register and current-conversion register follow the data format in the *Reading a Conversion (Read Cycle)* section. Register length depends on the number of conversions in one monitoring sequence. For example, when channel pairs 0/1 and channels 2/3 are monitored differentially, there are only two conversion results to report. The latched-fault register is 2 x 16 bits long, after which two current-conversion results follow. Likewise, if CS0 and CS1 limit the upper bound of the channel scan range from CH0 to CH2 in single-ended mode, the latched-fault register clocks out 3 x 16 bits of data followed by the current-conversion results, also 3 x 16 bits.

# 4-Channel, 12-Bit System Monitors with Programmable Trip Window and SMBus Alert Response

## Resetting Alarm

Reset alarms by writing to monitor-setup data. See the *Configuring Monitor Mode* section and Table 10.

## SMBus Alert

The SMBus-alert feature provides a quick method to identify alarming devices on a shared interrupt. Upon receiving an interrupt signal, the host  $\mu\text{C}$  can broadcast a receive byte request to the alert-response slave address (0001100). Any slave device that generated an interrupt attempts to identify itself by putting its own address on the bus. The alert response can activate several different slave devices simultaneously. If more than one slave attempts to respond, bus arbitration rules apply, and the device with the lower address wins as a consequence of the open-collector bus. The losing device does not generate an acknowledgement and continues to hold the alert line low until serviced. Successful reading of the alert response address deasserts  $\overline{\text{INT}}$ .

When the MAX1363/MAX1364 successfully send the I<sup>2</sup>C address, it can resume and reassert  $\overline{\text{INT}}$  right away (if the fault is still present). To prevent this from happening, monitor mode does not resume until after the host controller resets the alarm in the alarm status register. Any alarms not cleared when the device resumes monitor mode reassert  $\overline{\text{INT}}$ .

## Transfer Functions

Output data coding for the MAX1363/MAX1364 is binary in unipolar mode and two's complement in bipolar mode with  $1 \text{ LSB} = V_{\text{REF}} / 2^N$ , where N is the number of bits. Code transitions occur halfway between successive-integer LSB values. Figures 14 and 15 show the transfer functions for unipolar and bipolar operations, respectively.

## Layout, Grounding, and Bypassing

Only use PC boards. Wire-wrap configurations are not recommended since the layout should ensure proper separation of analog and digital traces. Do not run analog and digital lines parallel to each other, and do not layout digital signal paths underneath the ADC package. Use separate analog and digital PC board ground sections with only one star point (Figure 16).

High-frequency noise in the power supply ( $V_{\text{DD}}$ ) could influence the proper operation of the ADC's fast comparator. Bypass  $V_{\text{DD}}$  to the star ground with a network of two parallel capacitors, 0.1 $\mu\text{F}$  and 4.7 $\mu\text{F}$ , located as close as possible to the MAX1363/MAX1364 power supply. Minimize capacitor lead length for best supply noise rejection. For extremely noisy supplies, add an attenuation resistor (5 $\Omega$ ) in series with the power supply.

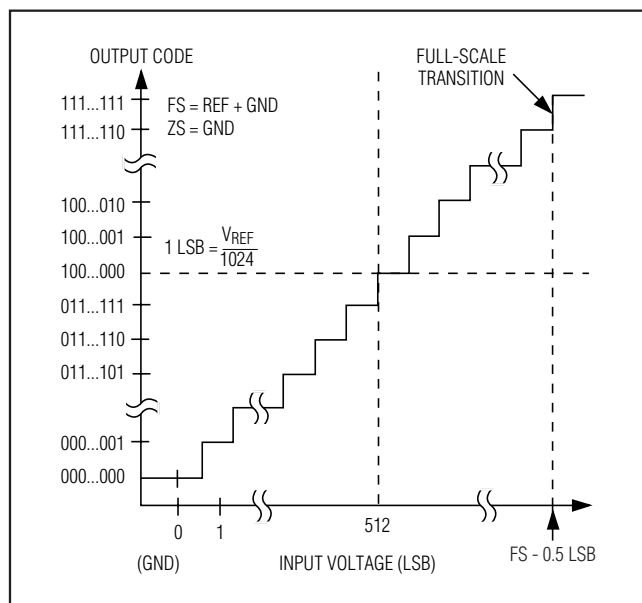

Figure 14. Unipolar Transfer Function

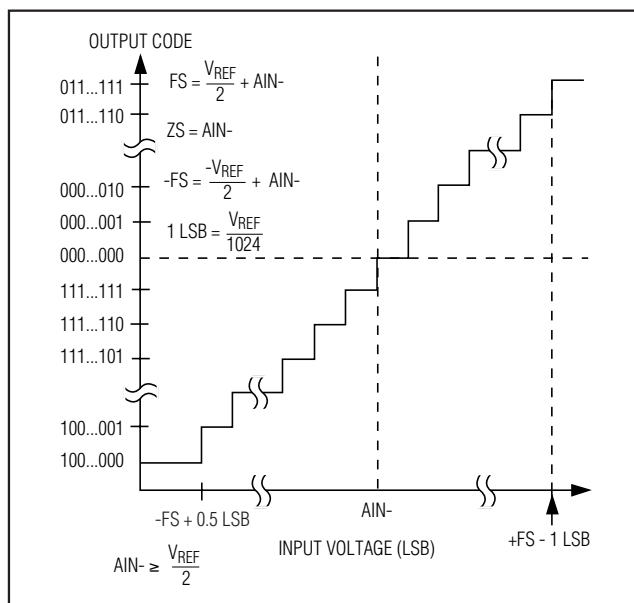

Figure 15. Bipolar Transfer Function

## 4-Channel, 12-Bit System Monitors with Programmable Trip Window and SMBus Alert Response

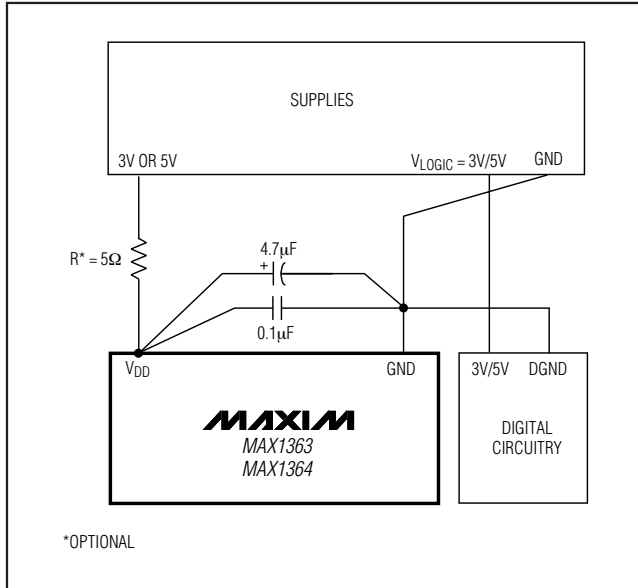

Figure 16. Power-Supply Grounding Connection

### Definitions

#### Integral Nonlinearity

Integral nonlinearity (INL) is the deviation of the values on an actual transfer function from a straight line. This straight line can be either a best straight-line fit or a line drawn between the endpoints of the transfer function, once offset and gain errors have been nullified. The MAX1363/MAX1364's INL is measured using the endpoint method.

#### Differential Nonlinearity

Differential nonlinearity (DNL) is the difference between an actual step width and the ideal value of 1 LSB. A DNL error specification of less than 1 LSB guarantees no missing codes and a monotonic transfer function.

#### Aperture Jitter

Aperture jitter ( $t_{AJ}$ ) is the sample-to-sample variation in the time between the samples.

#### Aperture Delay

Aperture delay ( $t_{AD}$ ) is the time between the falling edge of the sampling clock and the instant when an actual sample is taken.

#### Signal-to-Noise Ratio

For a waveform perfectly reconstructed from digital samples, the theoretical maximum SNR is the ratio of

the full-scale analog input (RMS value) to the RMS quantization error (residual error). The ideal, theoretical minimum analog-to-digital noise is caused by quantization error only and results directly from the ADC's resolution (N bits):

$$\text{SNR (MAX)}[\text{dB}] = 6.02\text{dB} \times N + 1.76\text{dB}$$

In reality, there are other noise sources besides quantization noise: thermal noise, reference noise, clock jitter, etc. SNR is computed by taking the ratio of the RMS signal to the RMS noise, which includes all spectral components minus the fundamental, the first five harmonics, and the DC offset.

#### Signal-to-Noise Plus Distortion

Signal-to-noise plus distortion (SINAD) is the ratio of the fundamental input frequency's RMS amplitude to RMS equivalent of all other ADC output signals.

$$\text{SINAD}(\text{dB}) = 20 \times \log(\text{Signal}_{\text{RMS}} / \text{Noise}_{\text{RMS}})$$

#### Effective Number of Bits

Effective number of bits (ENOB) indicates the global accuracy of an ADC at a specific input frequency and sampling rate. An ideal ADC's error consists of quantization noise only. With an input range equal to the ADC's full-scale range, calculate the ENOB as follows:

$$\text{ENOB} = (\text{SINAD} - 1.76) / 6.02$$

$$\text{SINAD}(\text{dB}) = 20 \times \log \left[ \frac{\text{Signal}_{\text{RMS}}}{\text{Noise}_{\text{RMS}} + \text{THD}_{\text{RMS}}} \right]$$

#### Total Harmonic Distortion

Total harmonic distortion (THD) is the ratio of the RMS sum of the input signal's first five harmonics to the fundamental itself. This is expressed as:

$$\text{THD} = 20 \times \log \left( \sqrt{\frac{V_2^2 + V_3^2 + V_4^2 + V_5^2}{V_1^2}} \right)$$

where  $V_1$  is the fundamental amplitude, and  $V_2$  through  $V_5$  are the amplitudes of the 2nd- through 5th-order harmonics.

#### Spurious-Free Dynamic Range

Spurious-free dynamic range (SFDR) is the ratio of RMS amplitude of the fundamental (maximum signal component) to the RMS value of the next largest distortion component.

# 4-Channel, 12-Bit System Monitors with Programmable Trip Window and SMBus Alert Response

**MAX1363/MAX1364**

**Pin Configuration**

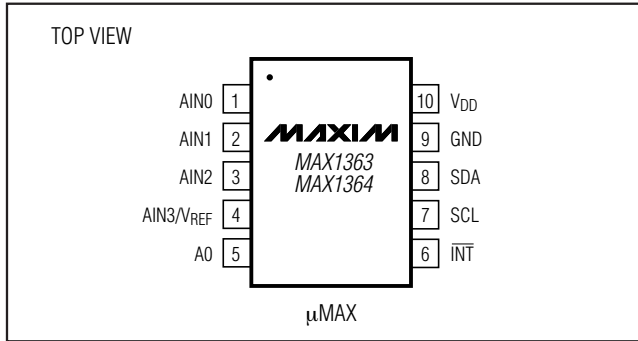

**Typical Operating Circuit**

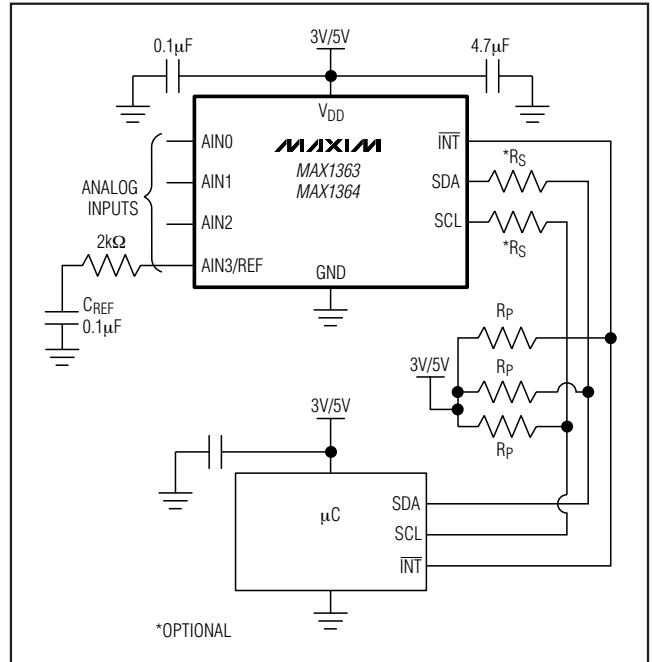

## Ordering Information/Selector Guide (continued)

PART	TEMP RANGE	PIN-PACKAGE	I <sup>2</sup> C SLAVE ADDRESS	SUPPLY VOLTAGE (V)
MAX1364EUB+	-40°C to +85°C	10 μMAX	0110100/0110101	4.5 to 5.5
MAX1364MEUB+	-40°C to +85°C	10 μMAX	0110110/0110111	4.5 to 5.5

+Denotes a lead-free package.

# **4-Channel, 12-Bit System Monitors with Programmable Trip Window and SMBus Alert Response**

## **Package Information**

For the latest package outline information, go to [www.maxim-ic.com/packages](http://www.maxim-ic.com/packages).

PACKAGE TYPE	PACKAGE CODE	DOCUMENT NO.
10 $\mu$ MAX	U10C+4	<a href="#">21-0061</a>

# 4-Channel, 12-Bit System Monitors with Programmable Trip Window and SMBus Alert Response

## Revision History

REVISION NUMBER	REVISION DATE	DESCRIPTION	PAGES CHANGED
2	3/07	Corrected Table 8	17
3	3/08	Removed L grade from data sheet	1, 13, 23

**MAX1363/MAX1364**

Maxim cannot assume responsibility for use of any circuitry other than circuitry entirely embodied in a Maxim product. No circuit patent licenses are implied. Maxim reserves the right to change the circuitry and specifications without notice at any time.

Maxim Integrated Products, 120 San Gabriel Drive, Sunnyvale, CA 94086 408-737-7600 \_\_\_\_\_ 25

## Looking for pricing, stock, or lifecycle information?

Click below to explore more details on WIN SOURCE:

- ⊖ [View MAX1364EUB+ on WIN SOURCE](#)
- ⊖ [Maxim Integrated Information](#)

## Optimize Your Supply Chain with WIN SOURCE Solutions

- ✓ Global Sourcing Solution
- ✓ Obsolete Management
- ✓ Cost Control Management
- ✓ Shortage Management
- ✓ Alternative Solution
- ✓ Excess Inventory Management