



**THE DATASHEET OF  
MASW-007813-TR3000**



## GaAs SP4T High Power Switch DC - 3 GHz

Rev. V2

### Features

- Low Voltage Operation: 2.5 V
- Low Harmonics: < -66 dBc at +34 dBm & 1 GHz
- Low Insertion Loss: 0.7 dB at 1 GHz
- High Isolation: 25 dB at 2 GHz
- 0.5 micron GaAs pHEMT Process
- Low Profile, Lead-Free 3 mm PQFN Package
- Halogen-Free "Green" Mold Compound
- RoHS\* Compliant and 260°C Re-flow Compatible

### Description

M/A-COM's MASW-007813 is a GaAs pHEMT MMIC single pole four throw (SP4T) high power switch in a low cost, low profile, lead-free 3 mm PQFN 16-lead package. The MASW-007813 is ideally suited for applications where high power, low control voltage, low insertion loss, high isolation, small size and low cost are required.

Typical applications are for GSM and DCS handset systems that connect separate transmit and receive functions to a common antenna, as well as CDMA handset and other related applications. The MASW-007813 can be used in all systems operating up to 3 GHz requiring high power at low control voltage.

The MASW-007813 is fabricated using a 0.5 micron gate length GaAs pHEMT process. The process features full passivation for performance and reliability.

### Ordering Information <sup>1,2</sup>

| Part Number        | Package         |
|--------------------|-----------------|
| MASW-007813-TR3000 | 3000 piece reel |
| MASW-007813-001SMB | Sample Board    |

1. Reference Application Note M513 for reel size information.
2. All sample boards include 5 loose parts.

### Functional Schematic

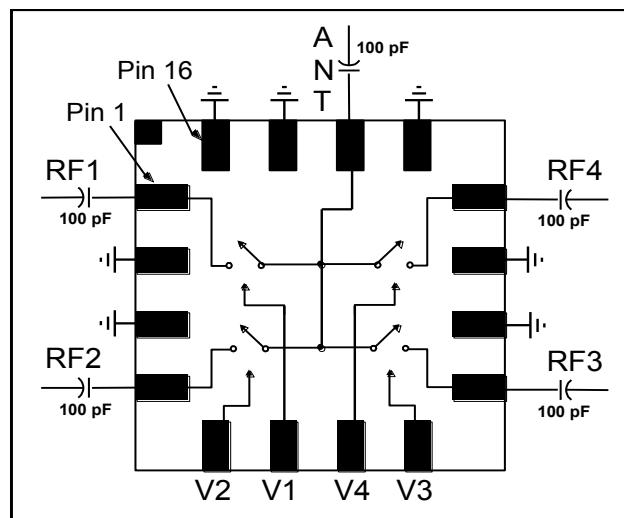

### Pin Configuration

| Pin No. | Pin Name                  | Description  |
|---------|---------------------------|--------------|
| 1       | RF1                       | RF Port 1    |
| 2       | GND                       | RF Ground    |
| 3       | GND                       | RF Ground    |
| 4       | RF2                       | RF Port 2    |
| 5       | V2                        | Control 2    |
| 6       | V1                        | Control 1    |
| 7       | V4                        | Control 4    |
| 8       | V3                        | Control 3    |
| 9       | RF3                       | RF Port 3    |
| 10      | GND                       | RF Ground    |
| 11      | GND                       | RF Ground    |
| 12      | RF4                       | RF Port 4    |
| 13      | GND                       | RF Ground    |
| 14      | ANT                       | Antenna Port |
| 15      | GND                       | RF Ground    |
| 16      | GND                       | RF Ground    |
| 17      | GND (paddle) <sup>3</sup> | RF Ground    |

3. The exposed pad centered on the package bottom must be connected to RF and DC ground.

\* Restrictions on Hazardous Substances, European Union Directive 2002/95/EC.

# MASW-007813

## GaAs SP4T High Power Switch DC - 3 GHz

Rev. V2

Electrical Specifications:  $T_A = 25^\circ\text{C}$ ,  $V_C = 0\text{ V} / 2.75\text{ V}$ ,  $P_{IN} = 34\text{ dBm}$ ,  $Z_0 = 50\ \Omega$  <sup>4</sup>

| Parameter                   | Test Conditions                                 | Units         | Min. | Typ. | Max. |
|-----------------------------|---|---------------|------|------|------|
| Insertion Loss <sup>5</sup> | DC - 1 GHz                                      | dB            | —    | 0.7  | 0.85 |
|                             | 1 - 2 GHz                                       |               | —    | 0.8  | —    |
|                             | 2 - 3 GHz                                       |               | —    | 1.0  | —    |
| Isolation                   | DC - 1 GHz                                      | dB            | 25   | 33   | —    |
|                             | 1 - 2 GHz                                       |               | —    | 27   | —    |
|                             | 2 - 3 GHz                                       |               | —    | 23   | —    |
| Return Loss                 | DC - 3 GHz                                      | dB            | —    | 20   | —    |
| P0.1dB                      | 1 GHz   | dBm           | —    | 38   | —    |
| IP2                         | Two Tone, +26 dBm/Tone, 5 MHz spacing, > 50 MHz | dBm           | —    | 96   | —    |
| IP3                         | Two Tone, +26 dBm/Tone, 5 MHz spacing, > 50 MHz | dBm           | —    | 58   | —    |
| 2nd Harmonic                | 1 GHz, Pin = +34 dBm                            | dBc           | —    | -76  | -68  |
| 3rd Harmonic                | 1 GHz, Pin = +34 dBm                            | dBc           | —    | -68  | -66  |
| Trise, Tfall                | 10% to 90% RF, 90% to 10% RF                    | ns            | —    | 40   | —    |
| Ton, Toff                   | 50% Control to 90% RF, 50% Control to 10% RF    | ns            | —    | 110  | —    |
| Transients                  |   | mV            | —    | 40   | —    |
| Control Current             | $V_C = 2.75\text{ V}$                           | $\mu\text{A}$ | —    | 20   | 80   |

4. For positive voltage control, external DC blocking capacitors are required on all RF ports.

5. Insertion loss can be optimized by varying the DC blocking capacitor value, e.g. 1000 pF for 100 MHz - 1 GHz, 39 pF for 0.5 GHz - 3 GHz.

### Truth Table <sup>6,7</sup>

| V1 | V2 | V3 | V4 | ANT - RF1 | ANT - RF2 | ANT - RF3 | ANT - RF4 |
|----|----|----|----|-----------|-----------|-----------|-----------|
| 1  | 0  | 0  | 0  | On        | Off       | Off       | Off       |
| 0  | 1  | 0  | 0  | Off       | On        | Off       | Off       |
| 0  | 0  | 1  | 0  | Off       | Off       | On        | Off       |
| 0  | 0  | 0  | 1  | Off       | Off       | Off       | On        |

6. Differential voltage, V (state 1) - V (state 0), must be +2.5 V minimum and must not exceed 8.5 V.

7. 0 = -8.5 V to 0 V, 1 = -6 V to 8.5 V

### Absolute Maximum Ratings <sup>8</sup>

| Parameter                                     | Absolute Maximum |
|---|------------------|
| Max Input Power (0.5 - 3 GHz, 2.75 V Control) | +38 dBm          |
| Operating Voltage                             | +8.5 volts       |
| Operating Temperature                         | -40°C to +85°C   |
| Storage Temperature                           | -65°C to +150°C  |

8. Exceeding any one or combination of these limits may cause permanent damage to this device.

# MASW-007813

GaAs SP4T High Power Switch  
DC - 3 GHz

Rev. V2

## Typical Performance Curves

**Insertion Loss**

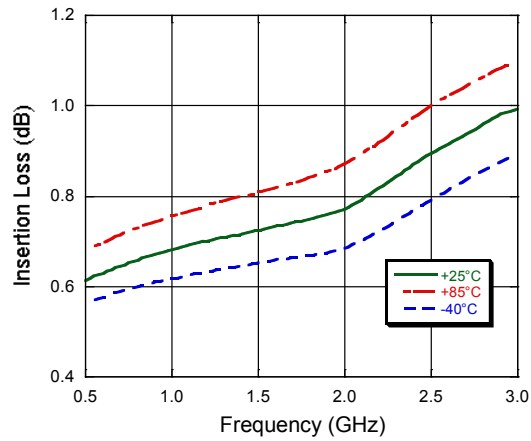

**Isolation**

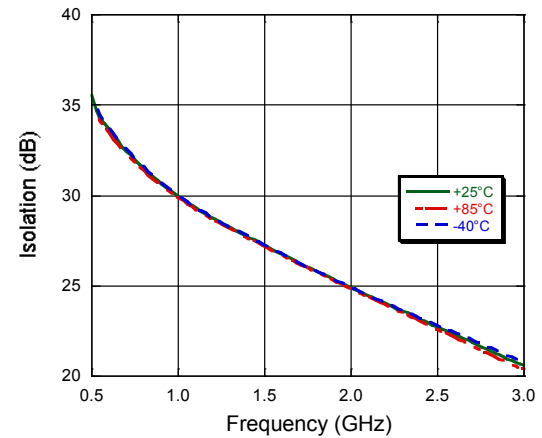

**Return Loss**

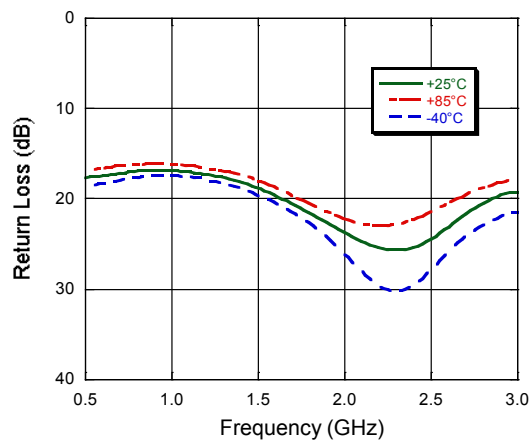

**Harmonics vs. Control Voltage, 1 GHz**

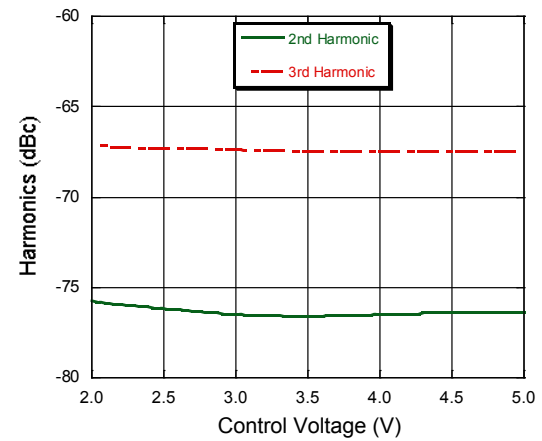



M/A-COM Technology Solutions Inc. All rights reserved.

Information in this document is provided in connection with M/A-COM Technology Solutions Inc ("MACOM") products. These materials are provided by MACOM as a service to its customers and may be used for informational purposes only. Except as provided in MACOM's Terms and Conditions of Sale for such products or in any separate agreement related to this document, MACOM assumes no liability whatsoever. MACOM assumes no responsibility for errors or omissions in these materials. MACOM may make changes to specifications and product descriptions at any time, without notice. MACOM makes no commitment to update the information and shall have no responsibility whatsoever for conflicts or incompatibilities arising from future changes to its specifications and product descriptions. No license, express or implied, by estoppel or otherwise, to any intellectual property rights is granted by this document.

THESE MATERIALS ARE PROVIDED "AS IS" WITHOUT WARRANTY OF ANY KIND, EITHER EXPRESS OR IMPLIED, RELATING TO SALE AND/OR USE OF MACOM PRODUCTS INCLUDING LIABILITY OR WARRANTIES RELATING TO FITNESS FOR A PARTICULAR PURPOSE, CONSEQUENTIAL OR INCIDENTAL DAMAGES, MERCHANTABILITY, OR INFRINGEMENT OF ANY PATENT, COPYRIGHT OR OTHER INTELLECTUAL PROPERTY RIGHT. MACOM FURTHER DOES NOT WARRANT THE ACCURACY OR COMPLETENESS OF THE INFORMATION, TEXT, GRAPHICS OR OTHER ITEMS CONTAINED WITHIN THESE MATERIALS. MACOM SHALL NOT BE LIABLE FOR ANY SPECIAL, INDIRECT, INCIDENTAL, OR CONSEQUENTIAL DAMAGES, INCLUDING WITHOUT LIMITATION, LOST REVENUES OR LOST PROFITS, WHICH MAY RESULT FROM THE USE OF THESE MATERIALS.

MACOM products are not intended for use in medical, lifesaving or life sustaining applications. MACOM customers using or selling MACOM products for use in such applications do so at their own risk and agree to fully indemnify MACOM for any damages resulting from such improper use or sale.

5

## Looking for pricing, stock, or lifecycle information?

Click below to explore more details on WIN SOURCE:

- ⊖ [View MASW-007813-TR3000 on WIN SOURCE](#)
- ⊖ [M/A-Com Technology Solutions Information](#)

## Optimize Your Supply Chain with WIN SOURCE Solutions

- ✓ Global Sourcing Solution
- ✓ Obsolete Management
- ✓ Cost Control Management
- ✓ Shortage Management
- ✓ Alternative Solution
- ✓ Excess Inventory Management