



**THE DATASHEET OF
MADR-009269-0001TR**



Features

- High Voltage CMOS Technology
- Complementary Outputs
- Positive Voltage Control
- CMOS device using TTL input levels
- Low Power Dissipation
- Low Cost Plastic SOIC-8 Package
- 100% Matte Tin Plating over Copper
- Halogen-Free “Green” Mold Compound
- RoHS* Compliant

Description

The MADR-009269 is a single channel CMOS driver used to translate TTL control inputs into complementary gate control voltages for GaAs FET microwave switches and attenuators. High speed analog CMOS technology is utilized to achieve low power dissipation at moderate to high speeds, encompassing most microwave switching applications. The output HIGH level is optionally 0 to 2 V (relative to GND) to optimize the intermodulation products of FET control devices at low frequencies. For driving PIN diode circuits, the outputs are nominally switched between +5 V & -5 V.

Functional Schematic

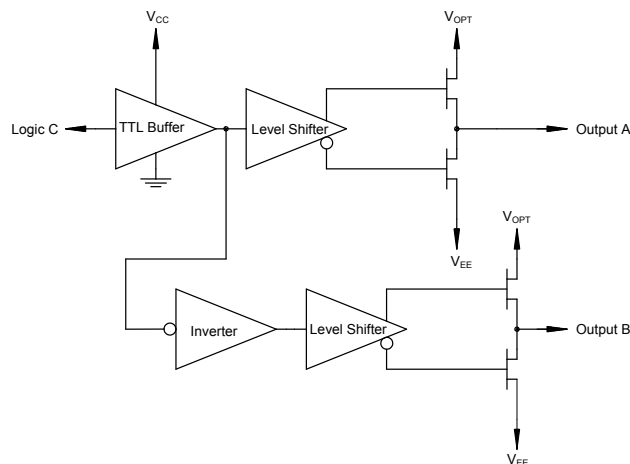

Pin Configuration²

Pin No.	Function
1	Output A
2	GND
3	V _{CC}
4	C, Logic
5	V _{EE}
6	V _{OPT}
7	GND
8	Output B

2. The bottom of the die should be isolated for part number MADR-009269-000DIE and MADR-009269-00GDIE.

Ordering Information¹

Part Number	Package
MADR-009269-000100	bulk packaging
MADR-009269-00GDIE	100 piece gel pack
MADR-009269-000DIE	100 piece waffle pack
MADR-009269-0001TR	1000 piece reel

1. Reference Application Note M513 for reel size information.

* Restrictions on Hazardous Substances, European Union Directive 2011/65/EU.

Single Driver for GaAs FET or PIN Diode Switches and Attenuators

Rev. V3

DC Characteristics over Guaranteed Operating Range

Symbol	Parameter	Test Conditions	Units	Min.	Typ.	Max.
V _{IH}	Input High Voltage	Guaranteed High Input Voltage	V	2.0	—	—
V _{IL}	Input Low Voltage	Guaranteed Low Input Voltage	V	—	—	0.8
V _{OH}	Output High Voltage	I _{OH} = -1 mA	V	V _{OPT} -0.1	—	—
V _{OL}	Output Low Voltage	I _{OL} = +1 mA	V	—	—	V _{EE} +0.1
I _{IN}	Input Leakage Current	V _{IN} = V _{CC} or GND, V _{EE} = min, V _{CC} = max, V _{OPT} = min or max	μA	-1	—	1
R _{NFET}	Output Resistance NFET On (to V _{EE})	V _{CC} = 5.0 V, V _{EE} = -5.0 V, V _{OPT} = 5.0 V, V _{OUT} = -4.9 V +25°C	Ω	—	30	—
R _{PFET}	Output Resistance PFET On (to V _{OPT})	V _{CC} = 5.0 V, V _{EE} = -5.0 V, V _{OPT} = 5.0 V, V _{OUT} = 4.9 V +25°C	Ω	—	30	—
I _{CC}	Quiescent Supply Current	V _{IN} = V _{CC} or GND, V _{EE} = -10.5 V, V _{CC} = 5.5 V, V _{OPT} = 5.5 V, No Output Load	μA	—	1	—
D I _{CC}	Additional Supply Current (per TTL Input pin)	V _{CC} = max, V _{IN} = V _{CC} -2.1 V	mA	—	1	—
I _{EE}	Quiescent Supply Current	V _{IN} = V _{CC} or GND, V _{EE} = -10.5 V, V _{CC} = 5.5 V, V _{OPT} = 5.5 V, No Output Load	μA	—	1	—
I _{OPT}	Quiescent Supply Current	V _{IN} = V _{CC} or GND, V _{EE} = -10.5 V, V _{CC} = 5.5 V, V _{OPT} = 5.5 V, No Output Load	μA	—	1	—

AC Characteristics Over Guaranteed Operating Range³

Symbol	Parameter	Unit	Typical performance		
			-40°C	+25°C	+85°C
T _{PLH}	Propagation Delay	ns	20	22	25
T _{PHL}	Propagation Delay	ns	20	22	25
T _{TLH}	Output Transition Time (Rising Edge)	ns	5	5	8
T _{THL}	Output Transition Time (Falling Edge)	ns	4	4	5
T _{skew}	Delay Skew	ns	2.5	2.5	2.5
PRF (max)	50% Duty Cycle	MHz	DC	—	10
C _{IN}	Input Capacitance	pF	5	5	5

3. V_{CC} = +4.5 V, V_{EE} = -4.5 V, V_{OPT} = 0 V or +4.5 V, C_L = 25 pF, T_{RISE}, T_{FALL} = 6 ns

Single Driver for GaAs FET or PIN Diode Switches and Attenuators

Rev. V3

Truth Table

Input	Outputs	
C	A	B
Logic "0"	V_{EE}	V_{OPT}
Logic "1"	V_{OPT}	V_{EE}

Handling Procedures

Please observe the following precautions to avoid damage:

Static Sensitivity

These electronic devices are sensitive to electrostatic discharge (ESD) and can be damaged by static electricity. Proper ESD control techniques should be used when handling these devices.

Guaranteed Operating Ranges^{4,5,6}

Symbol	Parameter	Unit	Min.	Typ.	Max.
V_{CC}	Positive DC Supply Voltage	V	4.5	5.0	5.5
V_{EE}	Negative DC Supply Voltage	V	-10.5	-5.0	-4.5
$V_{OPT}^{7,8}$	Optional DC Output Supply Voltage	V	0	—	V_{CC}
$V_{OPT} - V_{EE}$	Negative Supply Voltage Range	V	4.5	Note 7,8	16.0
$V_{CC} - V_{EE}$	Positive to negative Supply Range	V	9	10	16
T_{OPER}	Operating Temperature	°C	-40	+25	+85
I_{OH}	DC Output Current - High	mA	-50	—	—
I_{OL}	DC Output Current - Low	mA	—	—	50
T_{RISE}, T_{FALL}	Maximum Input Rise or Fall Time	ns	—	—	500

4. Unused logic inputs must be tied to either GND or V_{CC} .

5. MACOM recommends that V_{CC} be powered on before V_{EE} , and powered off after V_{EE} .

6. 0.01 μ F decoupling capacitors are required on the power supply lines.

7. V_{OPT} is grounded in most cases when FETs are driven. To improve the intermodulation performance and the 1 dB compression point of GaAs control devices at low frequencies, V_{OPT} can be increased to between 1 and 2 V. The nonlinear characteristics of the GaAs control devices will approximate performance at 500 MHz. It should be noted that the control current that is on the GaAs MMICs will increase when positive controls are applied.

8. When this driver is used to drive PIN diodes, V_{OPT} is often set to +5 V, with V_{EE} set to -5 V.

Absolute Maximum Ratings⁹

Symbol	Parameter	Unit	Min.	Max.
V_{CC}	Positive DC Supply Voltage	V	-0.5	7.0
I_{CC}	Positive DC Supply Current ($-0.5\text{ V} \leq V_{IN} \leq 0.8\text{ V}$; $2.0\text{ V} \leq V_{IN} \leq V_{CC} + 0.5\text{ V}$; $V_{CC} - V_{IN} \leq 7.0\text{ V}$)	mA	—	20
V_{EE}	Negative DC Supply Voltage	V	-11.0	0.5
I_{EE}	Negative DC Supply Current (per output) ¹⁰	mA	-60	—
V_{OPT}	Optional DC Output Supply Voltage	V	-0.5	Note 11
I_{OPT}	Optional DC Output Supply Current (per output) ¹⁰	mA	—	60
$V_{OPT} - V_{EE}$	Output to Negative Supply Voltage Range	V	-0.5	18.0
$V_{CC} - V_{EE}$	Positive to Negative Supply Voltage Range	V	-0.5	18.0
V_{IN}	DC Input Voltage	V	-0.5 Note 12	$V_{CC} + 0.5$
V_O	DC Output Voltage	V	$V_{EE} - 0.5$	$V_{OPT} + 0.5$
P_D ¹³	Power Dissipation in Still Air	mW	—	500
T_{OPER}	Operating Temperature	°C	-55	125
T_{STG}	Storage Temperature	°C	-65	150
ESD	ESD Sensitivity	kV	2.0	—

9. All voltages are referenced to GND. All inputs and outputs incorporate latch-up protection structures.

10. The maximum I_{EE} and I_{OPT} are specified under the condition of $V_{CC} = 5.5\text{ V}$, $V_{EE} = -5.5\text{ V}$, $V_{OPT} = 5.5\text{ V}$, and the total power dissipation is within 500 mW in still air.

11. The absolute maximum rating for V_{OPT} is $V_{CC} + 0.5\text{ V}$, or $+7.0\text{ V}$, whichever is less.

12. If $V_{CC} \geq 6.5\text{ V}$, then the minimum for V_{IN} is $V_{CC} - 7.0\text{ V}$.

13. Derate $-7\text{ mW}/^\circ\text{C}$ from 65°C to 85°C .

Switching Waveforms

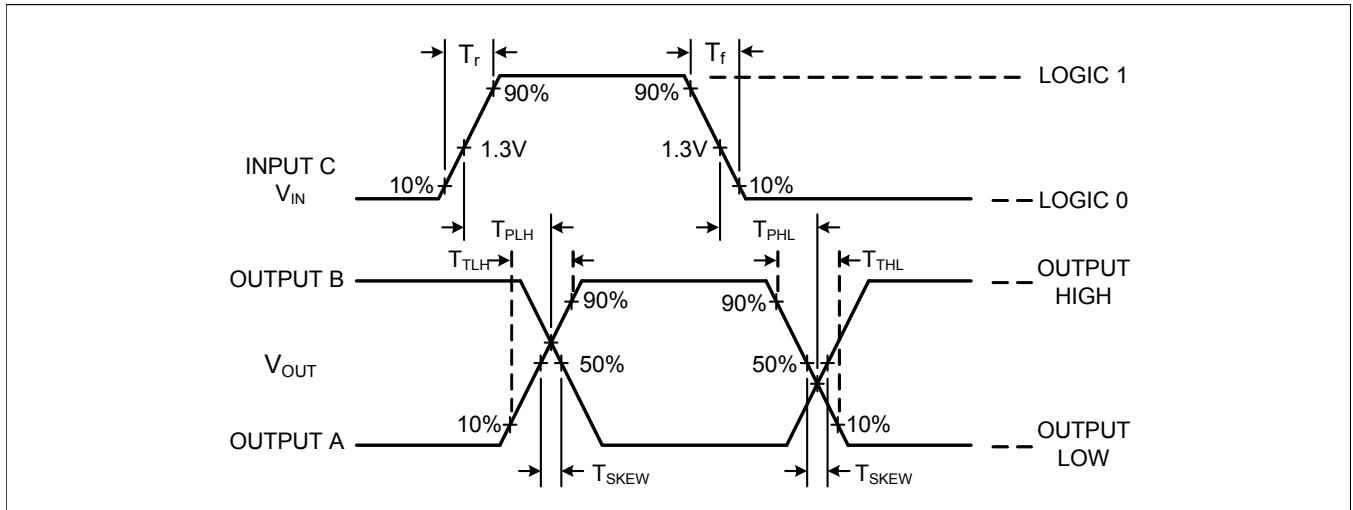

Equivalent Output Circuit for A and B Outputs (50 mA load at 25°C)

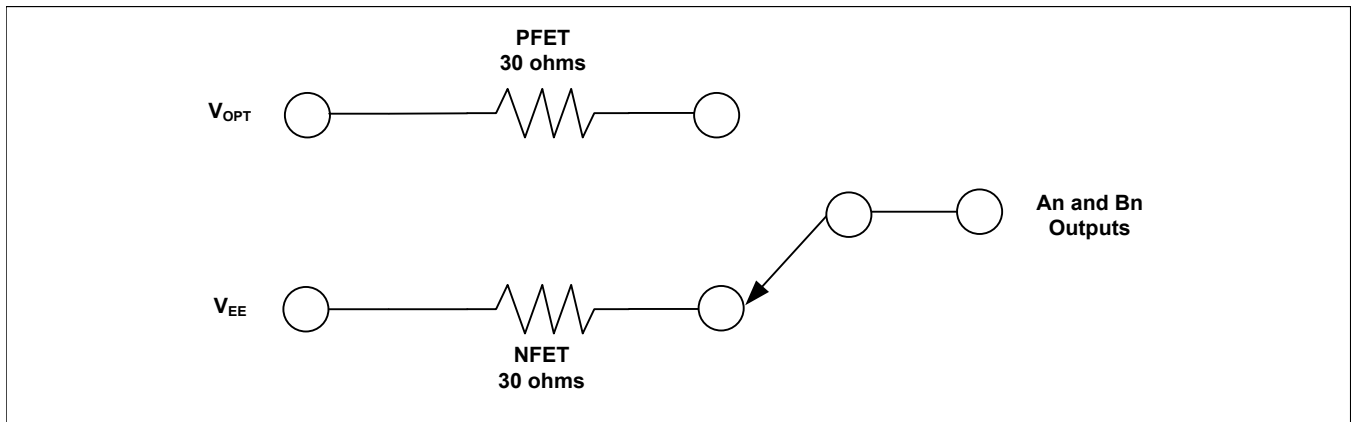

Typical Application for a SPDT Switch

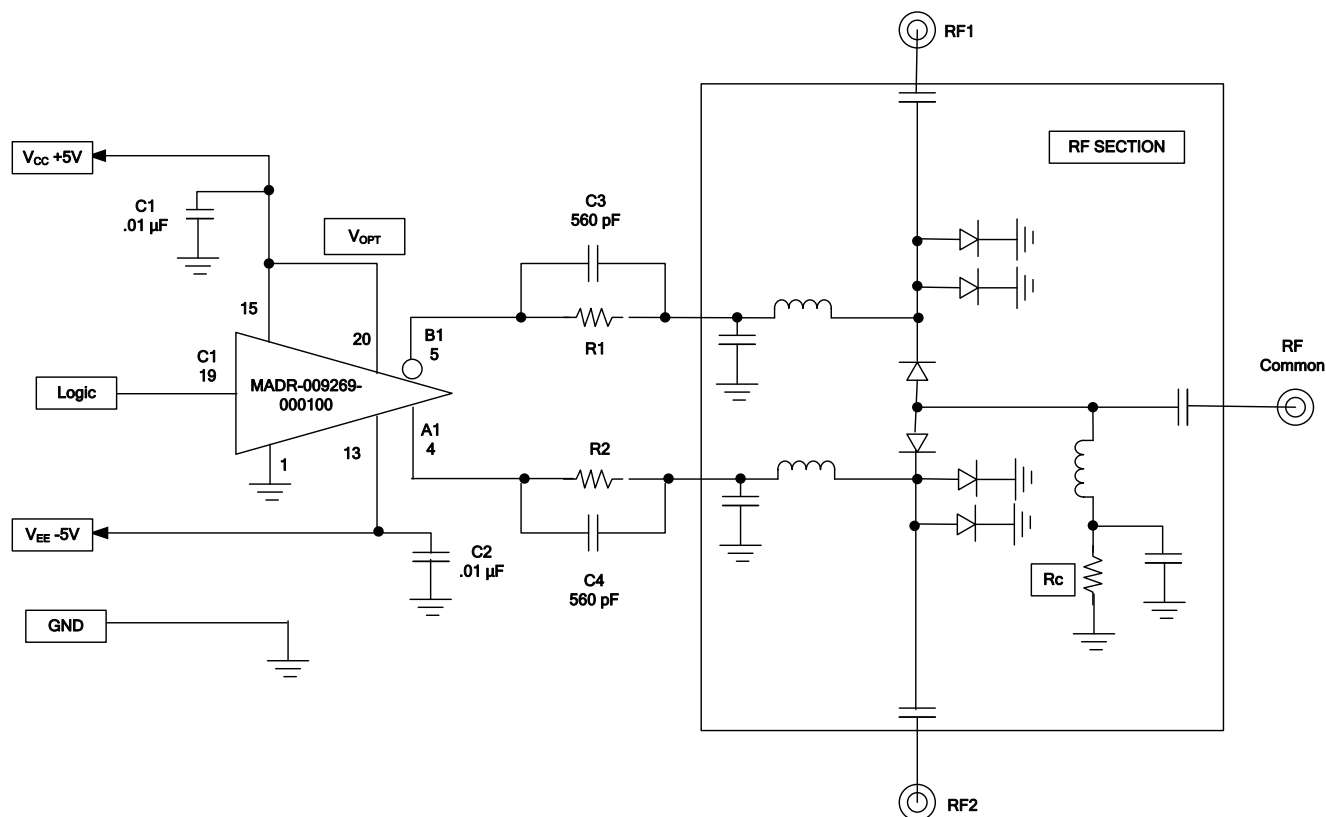

Description of Circuit

The MADR-009269 provides a pair of complementary outputs that are each capable of driving a maximum of ± 50 mA into a load. In addition, with proper capacitor selection (C3 & C4) used in parallel with the current setting resistor (R1 & R2), additional spiking current can be achieved.

To achieve the non-inverting and inverting complementary voltages, each output is switched between two internal FETs. The FETs are connected to V_{OPT} for the positive output and V_{EE} for the negative output. V_{OPT} and V_{EE} are adjustable for various configurations and have the following limitations: V_{EE} can be no more negative than -10.5 volts; V_{OPT} can be no more positive than +5.5 volts and V_{OPT} must always be less than or equal to V_{CC} . Increasing V_{OPT} beyond V_{CC} will prevent the device from switching states when commanded to by the logic input. The most common configuration is to drive V_{EE} at -5.0 volts with V_{CC} and V_{OPT} tied together at +5.0 volts.

Lead-Free, SOIC-8[†]

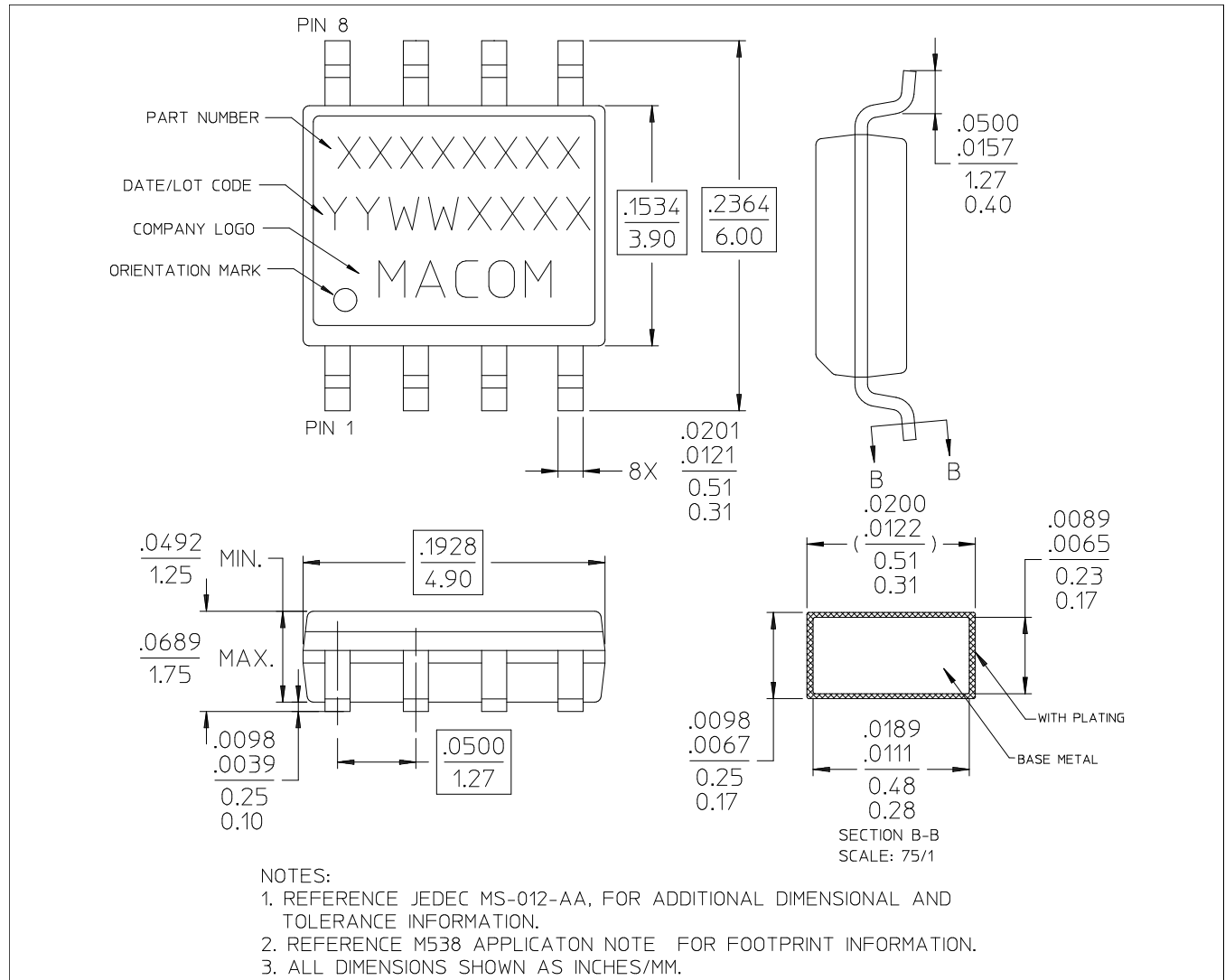

[†] Reference Application Note M538 for lead-free solder reflow recommendations. Plating is 100% matte tin over copper.

Die Outline

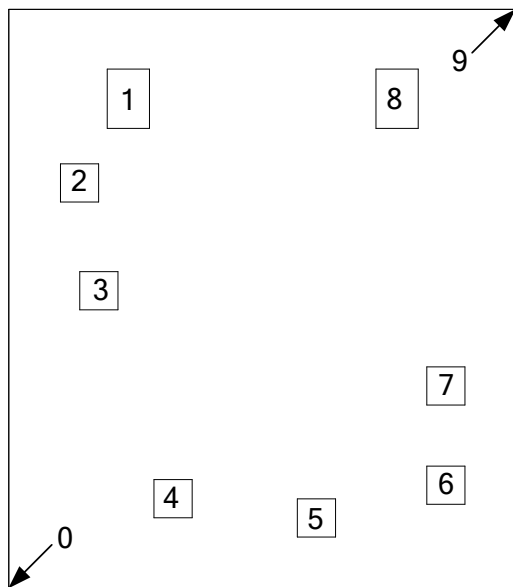

Pad Configuration^{14,15}

Die Size: 1130 x 1290 μm (nominal)

Pad No.	X (μm) nominal	Y (μm) nominal	Pad Size (μm) X x Y
0	0	0	Lower left edge of die
1	266.40	1092.35	94 x 132
2	157.50	903.70	85 x 85
3	200.40	663.65	85 x 85
4	365.30	200.45	85 x 85
5	684.35	157.50	85 x 85
6	972.50	230.50	85 x 85
7	972.50	451.45	85 x 85
8	863.60	1092.35	94 x 132
9	1130	1290	Upper right edge of die

- 14. All X,Y dimensions are at bond pad center.
- 15. Die thickness is 8.0 mils.

M/A-COM Technology Solutions Inc. All rights reserved.

Information in this document is provided in connection with M/A-COM Technology Solutions Inc ("MACOM") products. These materials are provided by MACOM as a service to its customers and may be used for informational purposes only. Except as provided in MACOM's Terms and Conditions of Sale for such products or in any separate agreement related to this document, MACOM assumes no liability whatsoever. MACOM assumes no responsibility for errors or omissions in these materials. MACOM may make changes to specifications and product descriptions at any time, without notice. MACOM makes no commitment to update the information and shall have no responsibility whatsoever for conflicts or incompatibilities arising from future changes to its specifications and product descriptions. No license, express or implied, by estoppel or otherwise, to any intellectual property rights is granted by this document.

THESE MATERIALS ARE PROVIDED "AS IS" WITHOUT WARRANTY OF ANY KIND, EITHER EXPRESS OR IMPLIED, RELATING TO SALE AND/OR USE OF MACOM PRODUCTS INCLUDING LIABILITY OR WARRANTIES RELATING TO FITNESS FOR A PARTICULAR PURPOSE, CONSEQUENTIAL OR INCIDENTAL DAMAGES, MERCHANTABILITY, OR INFRINGEMENT OF ANY PATENT, COPYRIGHT OR OTHER INTELLECTUAL PROPERTY RIGHT. MACOM FURTHER DOES NOT WARRANT THE ACCURACY OR COMPLETENESS OF THE INFORMATION, TEXT, GRAPHICS OR OTHER ITEMS CONTAINED WITHIN THESE MATERIALS. MACOM SHALL NOT BE LIABLE FOR ANY SPECIAL, INDIRECT, INCIDENTAL, OR CONSEQUENTIAL DAMAGES, INCLUDING WITHOUT LIMITATION, LOST REVENUES OR LOST PROFITS, WHICH MAY RESULT FROM THE USE OF THESE MATERIALS.

MACOM products are not intended for use in medical, lifesaving or life sustaining applications. MACOM customers using or selling MACOM products for use in such applications do so at their own risk and agree to fully indemnify MACOM for any damages resulting from such improper use or sale.

Looking for pricing, stock, or lifecycle information?

Click below to explore more details on WIN SOURCE:

- ⊖ [View MADR-009269-0001TR on WIN SOURCE](#)
- ⊖ [M/A-Com Technology Solutions Information](#)

Optimize Your Supply Chain with WIN SOURCE Solutions

- ✓ Global Sourcing Solution
- ✓ Obsolete Management
- ✓ Cost Control Management
- ✓ Shortage Management
- ✓ Alternative Solution
- ✓ Excess Inventory Management