



**THE DATASHEET OF  
MA4AGSW4**



### Features

- Ultra Broad Bandwidth: 50 MHz to 50 GHz
- Insertion Loss: 0.7 dB
- Isolation: 31 dB @ 50 GHz
- Low Current Consumption:
  - 10 mA for Low Loss State
  - +10 mA for Isolation State
- MACOMs Unique AlGaAs Hetero-Junction Anode Technology
- Silicon Nitride Passivation
- Polymer Scratch Protection
- RoHS\* Compliant

### Applications

- Aerospace & Defense
- ISM

### Description

The MA4AGSW4 is an Aluminum-Gallium-Arsenide, single pole, triple throw (SP4T), PIN diode switch. The switch features enhanced AlGaAs anodes which are formed using MACOM's hetero-junction technology. AlGaAs technology produces a switch with less loss than a device fabricated using conventional GaAs processes. As much as a 0.3 dB reduction in insertion loss can be realized at 50 GHz. This device is fabricated on an OMCVD epitaxial wafer using a process designed for high device uniformity and extremely low parasitics. The diodes within the chip exhibit low series resistance, low capacitance, and fast switching speed. They are fully passivated with silicon nitride and have an additional polymer layer for scratch protection. The protective coating prevents damage during handling and assembly to the diode junction and the chip anode air-bridges. Off chip bias circuitry is required.

The high electron mobility of AlGaAs and the low capacitance of the PIN diodes used makes this switch ideal for fast response, high frequency, multi-throw switch designs. AlGaAs PIN diode switches are an ideal choice for switching arrays in radar systems, radiometers, test equipment and other multi-assembly components.

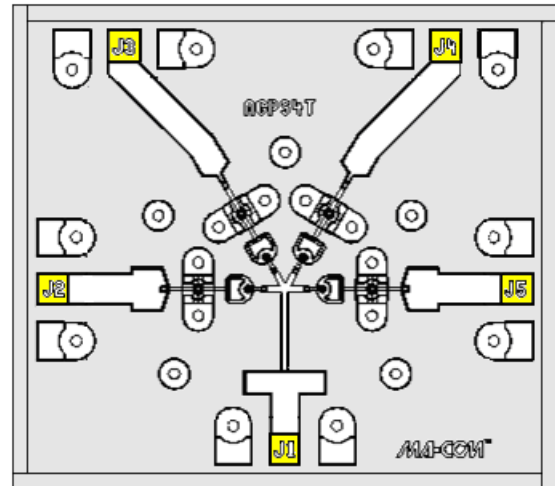

Yellow areas indicate bond pads

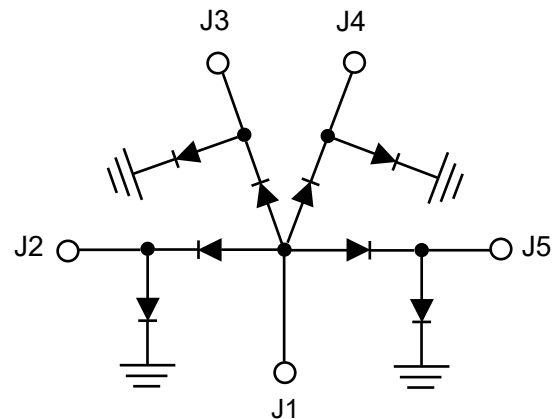

### Ordering Information

| Part Number | Package     |
|-------------|-------------|
| MA4AGSW4    | Waffle Pack |

\* Restrictions on Hazardous Substances, compliant to current RoHS EU directive.

**Electrical Specifications:  $T_A = +25^\circ\text{C}$ , +/-10 mA Bias Current (on wafer measurements)**

| Parameter                    | Test Conditions              | Units | Min.     | Typ.       | Max.       |
|------------------------------|------------------------------|-------|----------|------------|------------|
| Insertion Loss               | 0.05 - 18 GHz<br>18 - 50 GHz | dB    | —        | 0.7<br>1.0 | 0.8<br>1.4 |
| Isolation                    | 0.05 - 18 GHz<br>18 - 50 GHz | dB    | 25<br>25 | 41<br>32   | —          |
| Input Return Loss            | 0.05 - 18 GHz<br>18 - 50 GHz | dB    | 10<br>10 | 21<br>22   | —          |
| Output Return Loss           | 0.05 - 18 GHz<br>18 - 50 GHz | dB    | 10<br>10 | 26<br>17   | —          |
| Switching Speed <sup>1</sup> | 10 GHz                       | ns    | —        | 20         | —          |

1. Typical switching speed is measured from 10% to 90% of the detected RF voltage driven by a TTL compatible driver. Driver output parallel RC network uses a capacitor between 390 - 560 pF and a resistor between 150 - 220  $\Omega$  to achieve 20 ns rise and fall times.

**Absolute Maximum Ratings<sup>2,3</sup>:  $T_A = +25^\circ\text{C}$**

| Parameter                | Absolute Maximum   |
|--------------------------|--|
| DC Reverse Voltage       | 25 V   |
| Maximum Bias Current     | $\pm 25$ mA  |
| Recommended Bias Current | $\pm 15$ mA @ $+25^\circ\text{C}$<br>$\pm 10$ mA @ $+85^\circ\text{C}$ |
| Incident C.W. RF Power   | +23 dBm C.W. @ 10 mA, $+85^\circ\text{C}$                              |
| Junction Temperature     | $+150^\circ\text{C}$   |
| Operating Temperature    | $-55^\circ\text{C}$ to $+125^\circ\text{C}$                            |
| Storage Temperature      | $-55^\circ\text{C}$ to $+150^\circ\text{C}$                            |
| Assembly Temperature     | $+300^\circ\text{C}$ <10 seconds                                       |

2. Exceeding any one or combination of these limits may cause permanent damage to this device.

3. MACOM does not recommend sustained operation near these survivability limits.

Typical RF Performance Curves: @ +25°C (Probed on Wafer)

Insertion Loss

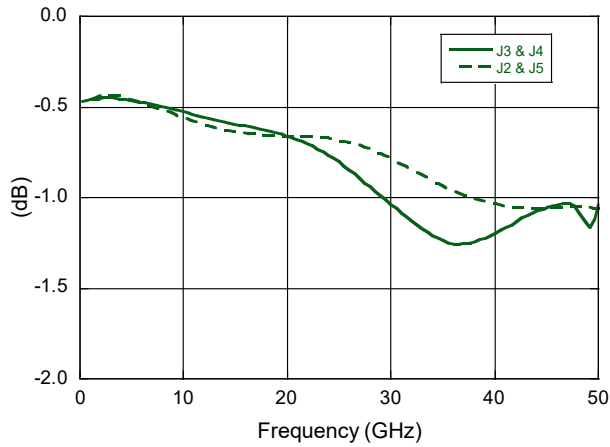

Isolation

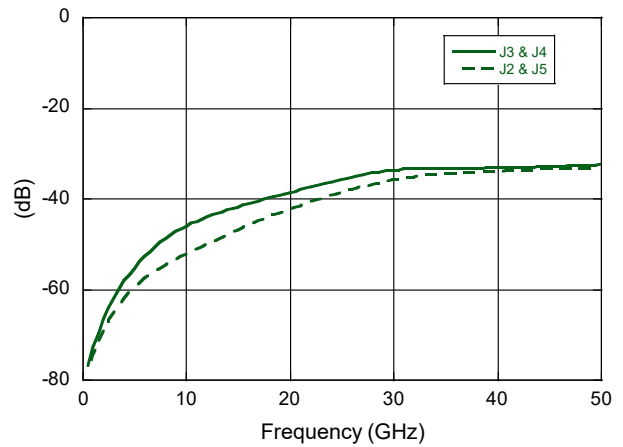

Input Return Loss

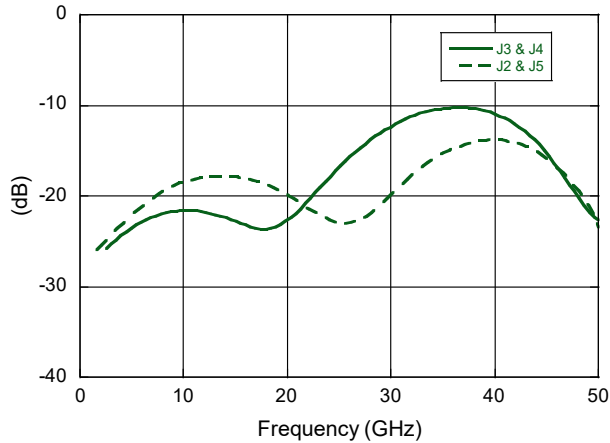

Output Return Loss

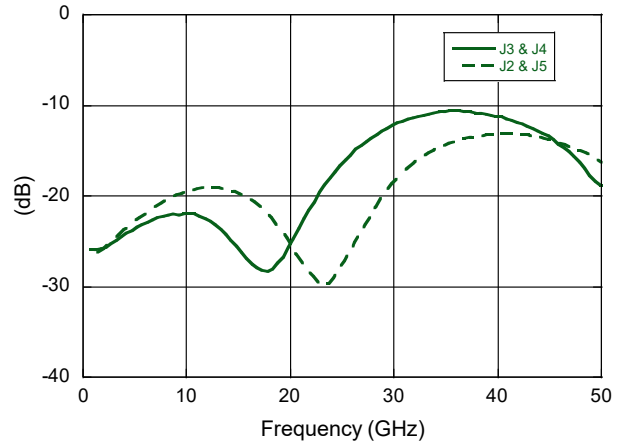

## Operation of the MA4AGSW4 Switch

The MA4AGSW4 single-pole four-throw reflective switch, comprising a series and a shunt AlGaAs PIN diode in each of four identical arms. It is intended to be operated with one of these arms biased to produce low insertion loss between the RF common port and its switched port with the remaining three arms biased to produce high isolation between the RF common port and their respective switched ports. The underside of this die is fully metalized and forms the DC, RF, and thermal ground connection of the switch.

Please refer to the MA4AGSW4 Schematic with Typical External 2 - 18 GHz Bias Network (Page 5).

For example, to produce low insertion loss in the J1-to-J2 path, a negative current of nominally 10 mA (25 mA absolute maximum) is applied to the DC Bias port connected to J2 via the bias tee which comprises a 39 pF shunt capacitor and a 22 nH RF choke. This forces the series diode between J1 and J2 into conduction while reverse biasing the shunt PIN diode between J2 and ground. At the same time, positive currents of nominally 10 mA (25 mA absolute maximum) are applied to the DC bias inputs connected via bias tees to ports J3, J4 and J5. This condition reverse biases each of the series diodes in these arms while forward biasing each of the respective shunt diodes, thus producing high isolation in these signal paths.

The typical forward voltage of the diodes in this switch while under forward bias of 10 mA is 1.4 V. MACOM recommends the bias tees should produce a minimum of 30 dB isolation between the RF signal path and the bias source. Please refer to the data sheets for MACOM's integrated HMIC™ bias tees, MA4BN1840-1 and MA4BN1840-2 or MABT-011000, available from [www.macom.com](http://www.macom.com), for additional information.

MA4AGSW4 Schematic with a Typical External 2 - 18 GHz Bias Network

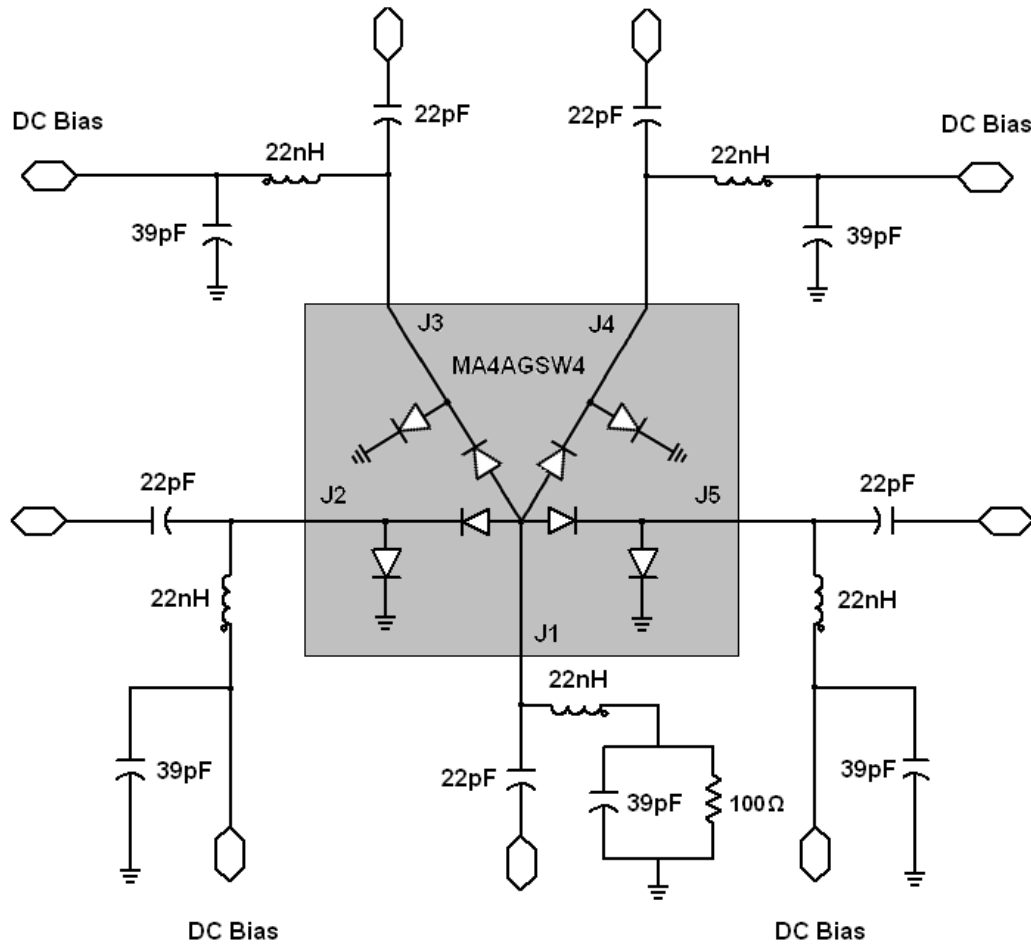

Typical Driver Connections

| Control Levels (DC Current) |        |        |        | Condition of RF Output |           |           |           |
|-----------------------------|--------|--------|--------|------------------------|-----------|-----------|-----------|
| J2                          | J3     | J4     | J5     | J2-J1                  | J3-J1     | J4-J1     | J5-J1     |
| -10 mA                      | +10 mA | +10 mA | +10 mA | Low Loss               | Isolation | Isolation | Isolation |
| +10 mA                      | -10 mA | +10 mA | +10 mA | Isolation              | Low Loss  | Isolation | Isolation |
| +10 mA                      | +10 mA | -10 mA | +10 mA | Isolation              | Isolation | Low Loss  | Isolation |
| +10 mA                      | +10 mA | +10 mA | -10 mA | Isolation              | Isolation | Isolation | Low Loss  |

Chip Dimensions and Bonding Pad Locations (In Yellow)

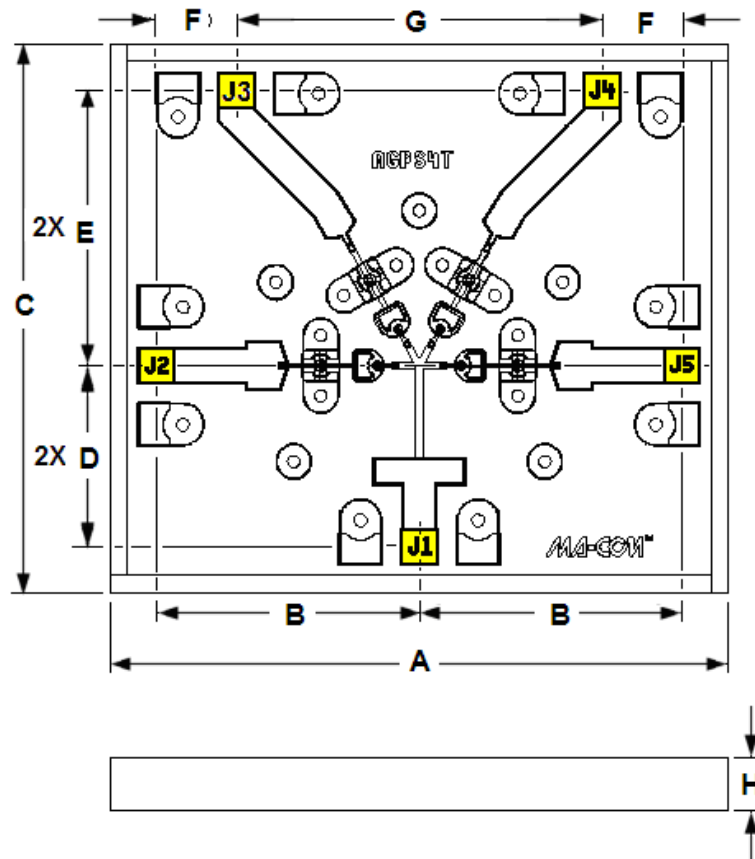

Chip Dimensions

| Dimension | mils    |         |         | mm      |         |         |
|-----------|---------|---------|---------|---------|---------|---------|
|           | Minimum | Nominal | Maximum | Minimum | Nominal | Maximum |
| A         | 66.0    | 67.0    | 68.0    | 1.676   | 1.702   | 1.727   |
| B         | 28.5    | 29.0    | 29.5    | 0.724   | 0.737   | 0.749   |
| C         | 50.0    | 60.0    | 61.0    | 1.270   | 1.524   | 1.549   |
| D         | 19.5    | 20.0    | 20.5    | 0.495   | 0.508   | 0.521   |
| E         | 29.5    | 30.0    | 30.5    | 0.749   | 0.762   | 0.775   |
| F         | 8.5     | 9.0     | 9.5     | 0.216   | 0.229   | 0.241   |
| G         | 39.5    | 40.0    | 40.5    | 1.003   | 1.016   | 1.029   |
| H         | 3.5     | 4.0     | 4.5     | 0.089   | 0.102   | 0.114   |
| PADS      | 3.5     | 4.0     | 4.5     | 0.089   | 0.102   | 0.114   |

## Assembly Instructions

### Cleanliness

The chip should be handled in a clean environment.

### Static Sensitivity

This device is considered ESD Class 1A, HBM. Proper ESD techniques should be used during handling.

### General Handling

The protective polymer coating on the active areas of the die provides scratch and impact protection, particularly for the metal air bridge, which contacts the diode's anode. Die should primarily be handled with vacuum pickup tools, or alternatively with plastic tweezers.

### Assembly Techniques

The MA4AGSW4, AlGaAs switch is designed to be mounted with electrically conductive silver epoxy or with a low temperature solder perform, which does not have a rich tin content.

### Solder DIE Attach

Only solders which do not scavenge gold, such as 80Au/20Sn or Indalloy #2 is recommended. Do not expose die to temperatures >300°C for more than 10 seconds.

### Conductive Epoxy DIE Attach

Use a controlled thickness of approximately 2 mils for best electrical conductivity and lowest thermal resistance. Cure epoxy per manufacturer's schedule. Typically 150°C for 1 hour.

### Ribbon/Wire Bonding

Thermo-compression wedge or ball bonding may be used to attach ribbons or wire to the gold bonding pads. A 1/4 x 3 mil gold ribbon is recommended on all RF ports and should be kept as short as possible for the lowest inductance and best microwave performance. For more detailed handling and assembly instructions, see Application Note M541, "Bonding and Handling Procedures for Chip Diode Devices" at [www.macom.com](http://www.macom.com).

MACOM Technology Solutions Inc. ("MACOM"). All rights reserved.

These materials are provided in connection with MACOM's products as a service to its customers and may be used for informational purposes only. Except as provided in its Terms and Conditions of Sale or any separate agreement, MACOM assumes no liability or responsibility whatsoever, including for (i) errors or omissions in these materials; (ii) failure to update these materials; or (iii) conflicts or incompatibilities arising from future changes to specifications and product descriptions, which MACOM may make at any time, without notice. These materials grant no license, express or implied, to any intellectual property rights.

THESE MATERIALS ARE PROVIDED "AS IS" WITH NO WARRANTY OR LIABILITY, EXPRESS OR IMPLIED, RELATING TO SALE AND/OR USE OF MACOM PRODUCTS INCLUDING FITNESS FOR A PARTICULAR PURPOSE, MERCHANTABILITY, INFRINGEMENT OF INTELLECTUAL PROPERTY RIGHT, ACCURACY OR COMPLETENESS, OR SPECIAL, INDIRECT, INCIDENTAL, OR CONSEQUENTIAL DAMAGES WHICH MAY RESULT FROM USE OF THESE MATERIALS.

MACOM products are not intended for use in medical, lifesaving or life sustaining applications. MACOM customers using or selling MACOM products for use in such applications do so at their own risk and agree to fully indemnify MACOM for any damages resulting from such improper use or sale.

## Looking for pricing, stock, or lifecycle information?

Click below to explore more details on WIN SOURCE:

- ⊖ [View MA4AGSW4 on WIN SOURCE](#)
- ⊖ [M/A-Com Technology Solutions](#) Information

## Optimize Your Supply Chain with WIN SOURCE Solutions

- ✓ Global Sourcing Solution
- ✓ Obsolete Management
- ✓ Cost Control Management
- ✓ Shortage Management
- ✓ Alternative Solution
- ✓ Excess Inventory Management