



**THE DATASHEET OF
LXRW0YV600-054**



1. This specification shall be applied to the VARIABLE CAPACITOR.

LXRW0YV600-054



2. Features

- This device can carry out variable of the capacitor by adjusting the tuning voltage.
- This device can be used as a device for frequency adjustments of FeliCa(NFC) like switch IC(Capacitor embedded type) or a trimmer capacitor. Of course, other various cases can be used.

3. Part Number Configuration

LXRW 0Y V 600 - 054
① ② ③ ④ ⑤

- ① Product ID (LXRW = Variable Capacitor)
- ② Dimension Code
- ③ Control Code
- ④ Capacitance
- ⑤ Serial Number

※RoHS Compliant
MSL 3
Halogen free
T/R only.

4. Construction, Dimensions

4-1. Dimensions

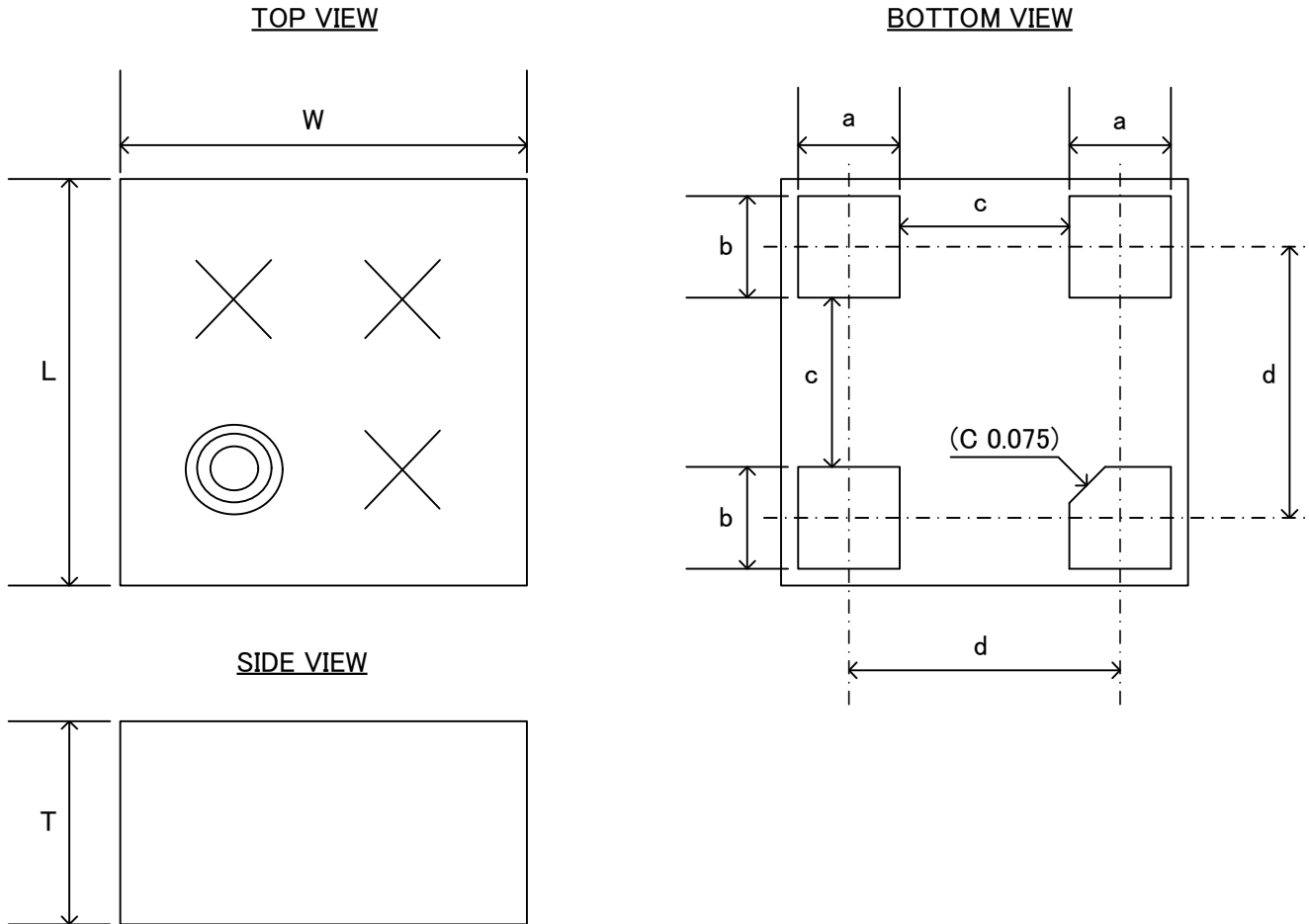

Unit: mm

Mark	Size	Mark	Size
L	0.6 +/- 0.03	a	0.15 +/- 0.015
W	0.6 +/- 0.03	b	0.15 +/- 0.015
T	0.3 MAX	c	(0.25)
		d	(0.40)

4-2. Pin assignments

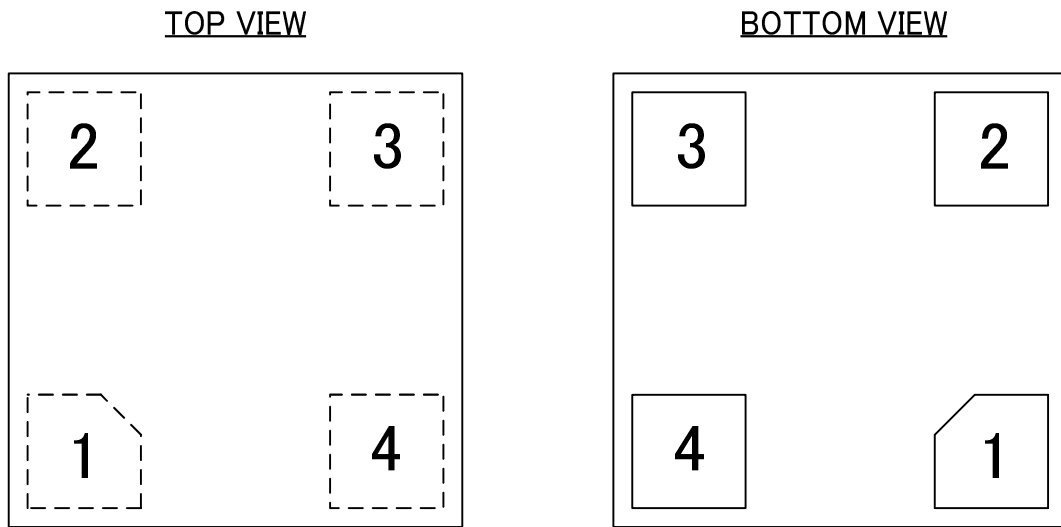

Pin No.	Pin Name	Description
1	GND	Ground
2	Vt	V_tune
3	Port1	RF port
4	Port2	RF port

5. Marking structure

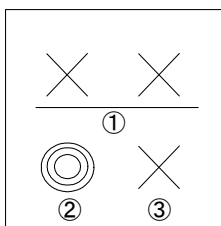

- ① Trace code
- ② 1pin Mark
- ③ Device code

6. Equivalent circuit

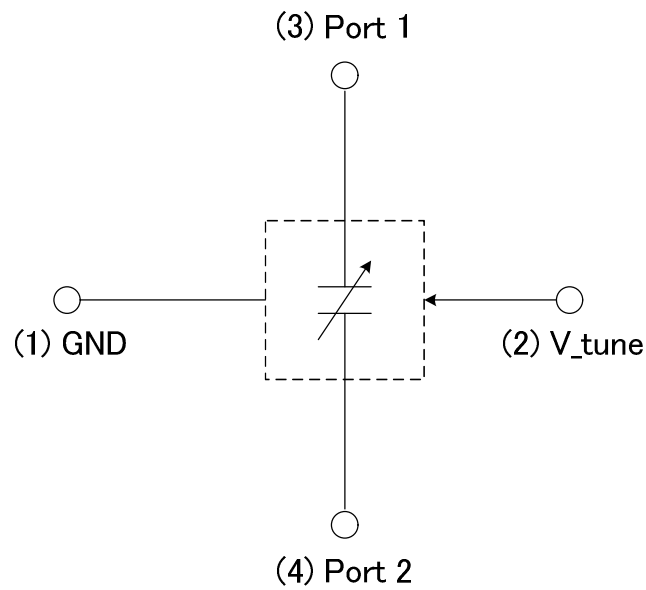

7. Characteristics

[ELECTRICAL CHARACTERISTICS]

7-1. Maximum ratings

Rating	Symbol	Value	Unit
Continuous Tuning Voltage	V_T	3.2	V
Rated Voltage	V_{ac}	50	Vp-p
Operating Temperature	T_{OP}	-30 to +85	°C
Storage Temperature	T_{STO}	-40 to +85	°C

7-2. Electrical characteristics (T=25 +/- 5 °C)

Parameter	Symbol	Conditions	MIN	TYP	MAX	Unit
Capacitance	C_{vc}	$V_T=0V$ f=1MHz		60		pF
		$V_T=3V$ f=1MHz		30		pF

8. Capacitance characteristics(Typical)

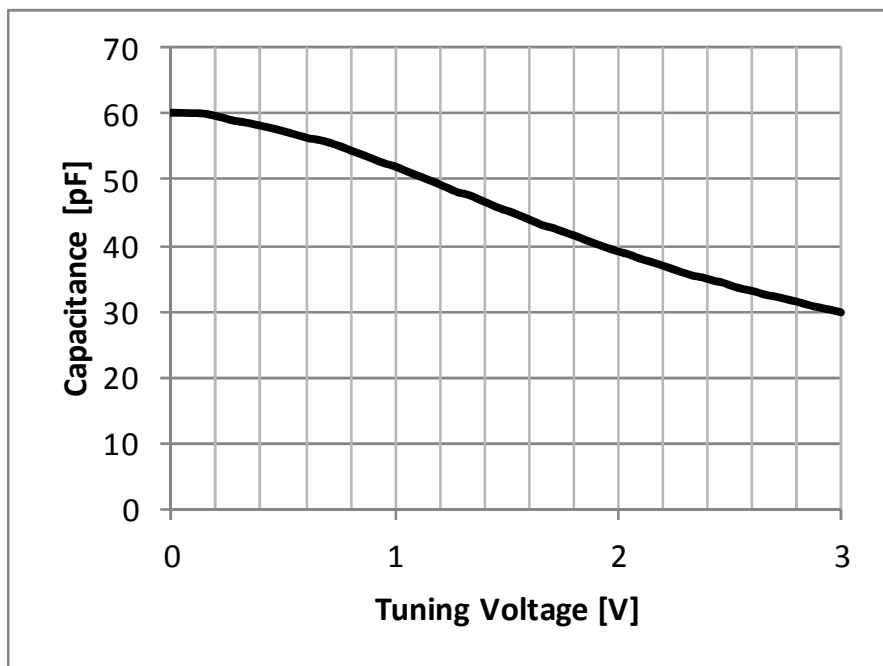

9. Application Circuit

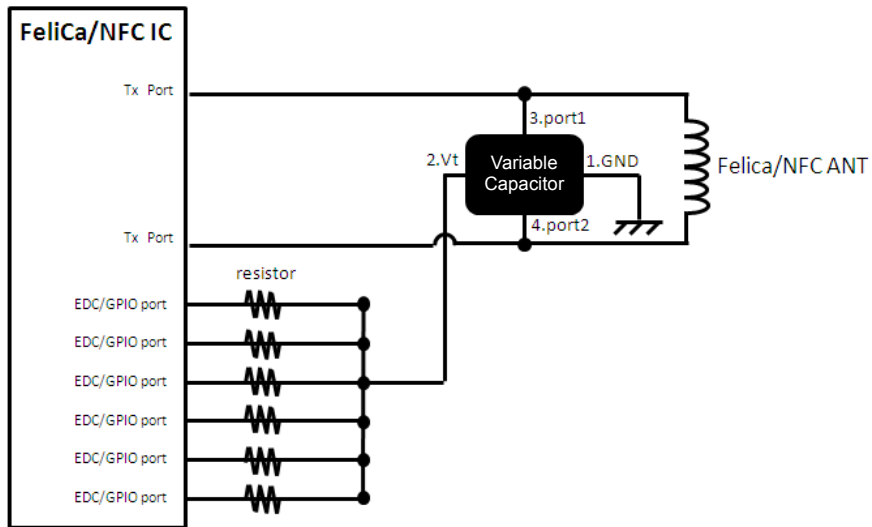

Resister Value[Ω]	Number of EDC/GPIO port			
	3port	4port	5port	6port
R1	240K	180K	180K	180K
R2	510K	360K	360K	360K
R3	1M	750K	750K	750K
R4	-	1.5M	1.5M	1.5M
R5	-	-	3.0M	3.0M
R6	-	-	-	6.2M

10. Reliability Test

【Mechanical Test】

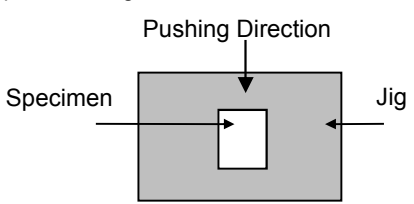
No.	Items	Specifications	Test Methods	Number	Result (Fail)
1	Vibration Resistance	No severe damages	Solder specimens on the testing jig (glass fluorine boards) shown in appended Fig.1 by a Pb free solder. The soldering shall be done either by iron or reflow and be conducted with care so that the soldering is uniform and free of defect such as by heat shock. Frequency : 10~2000 Hz Acceleration : 196 m/s ² Direction : X,Y,Z 3 axis Period : 2.5 h on each direction Total 7.5 h.	22	G (0)
2	Shock		Solder specimens on the testing jig shown in appended Fig.1 by an eutectic solder. The soldering shall be done either by iron or reflow and be conducted with care so that the soldering is uniform and free of defect such as by heat shock. Acceleration : 981 m/s ² Period : 6 ms. Cycle : 6 axis ×10 times	22	G (0)
3	Deflection		Solder specimens on the testing jig (glass epoxy boards) shown in appended Fig.2 by a Pb free solder. The soldering shall be done either by iron or reflow and be conducted with care so that the soldering is uniform and free of defect such as by heat shock. No damage with 1.6mm deflection	22	G (0)
4	Soldering strength (Push Strength)	2N Minimum	Solder specimens onto test jig shown below. Apply pushing force at 0.5mm/s until electrode pads are peeled off or product is broken. Pushing force is applied to longitudinal direction.  <p>The diagram shows a rectangular specimen mounted on a larger rectangular jig. A vertical arrow labeled 'Pushing Direction' points downwards from the top of the specimen. A horizontal arrow labeled 'Jig' points from the right side of the jig towards the specimen. The specimen is centered within the jig.</p>	22	G (0)
5	Solderability of Termination	95% of the terminations is to be soldered evenly and continuously.	Immerse specimens first an ethanol solution of rosin, then in a Pb free solder solution for 3±0.5 sec. at 245±5 °C. Preheat : 150 °C, 60 sec. Solder Paste : Sn-3.0Ag-0.5Cu Flux : Solution of ethanol and rosin (25 % rosin in weight proportion)	22	G (0)
6	Resistance to Soldering Heat (Reflow)	No severe damages Satisfy specifications listed in paragraph 7-2 over operational temperature range	Preheat Temperature : 150-200 °C Preheat Period : 60-180 sec. High Temperature : 217 °C High Temp. Period : 60-150 sec. Peak Temperature : 255-260 °C Specimens are soldered twice with the above condition, and then kept in room condition for 24 h before measurements.	22	G (0)

No.	Items	Specifications	Test Methods	Number	Result (Fail)
7	Chip Place Test	No severe damages Satisfy specifications listed in paragraph 7-2 over operational temperature range	Nozzle: Buffing Nozzle (With shock absorption mechanism) diameter (vacuum): $\phi 0.4$ mm Push quantity: +0.4 mm Loading: 13 N(max)	22	G (0)

【Environmental Test】

No.	Items	Specifications	Test Methods	Number	Result (Fail)									
8	High Temp. Exposure	No severe damages	Temperature : 85 ± 2 °C Period : 500+48/-0 h Room Condition : 2 ~ 24 h	22	G (0)									
9	Temperature Cycle		Set the specimens to the supporting jig in the same manner and under the same conditions as Fig.1 and conduct the 100 cycles according to the temperatures and time shown in the following table. Set it for 2 to 24 h at room temperature, then measure.	22	G (0)									
			<table border="1"> <thead> <tr> <th>Step</th> <th>Temp(°C)</th> <th>Time(min)</th> </tr> </thead> <tbody> <tr> <td>1</td> <td>Min. Operating Temp.+0/-3</td> <td>30±3</td> </tr> <tr> <td>2</td> <td>Max. Operating Temp.+3/-0</td> <td>30±3</td> </tr> </tbody> </table>	Step	Temp(°C)	Time(min)	1	Min. Operating Temp.+0/-3	30±3	2	Max. Operating Temp.+3/-0	30±3		
Step	Temp(°C)	Time(min)												
1	Min. Operating Temp.+0/-3	30±3												
2	Max. Operating Temp.+3/-0	30±3												
10	Humidity (Steady State)	Satisfy specifications listed in paragraph 7-2 over operational temperature range	Temperature : 40 ± 2 °C Humidity : 80~90 %RH Period : 500±12 h Room Condition : 2~24 h	22	G (0)									
11	Low Temp. Exposure		Temperature : -40 ± 2 °C Period : 500+48/-0 h Room Condition : 2~24 h	22	G (0)									
12	ESD Machine Model		C: 200pF R: 0Ω EST Voltage : +/-200V Number of electric discharges: 1	10	G (0)									
13	ESD Human Body Model		C: 100pF R: 1500Ω EST Voltage : +/-400V Number of electric discharges: 1	10	G (0)									

Fig. 1
Reference Land Pattern

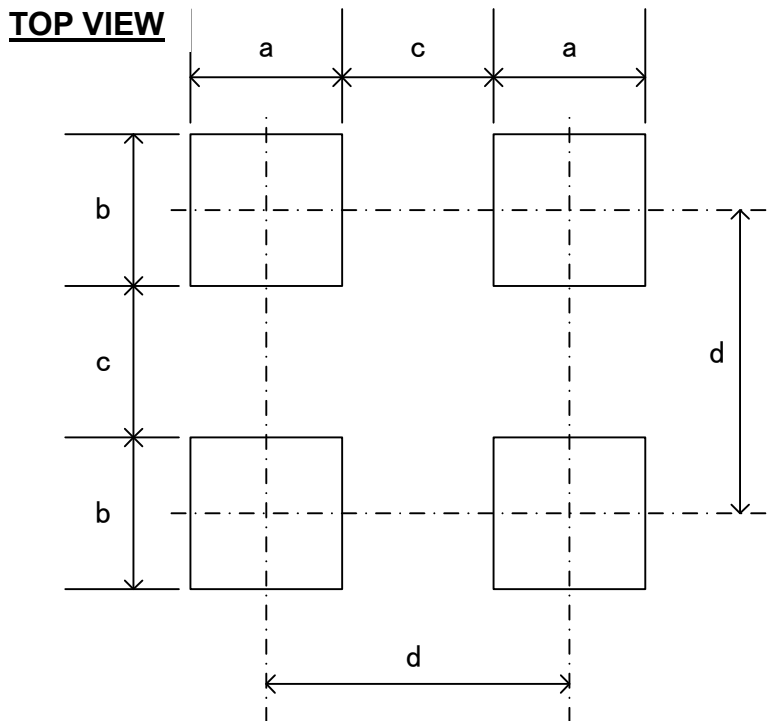

Unit: mm

Mark	Size	Mark	Size
a	0.20	c	(0.2)
b	0.20	d	(0.4)

This land pattern is for reference purpose only.

Fig. 2
Testing board

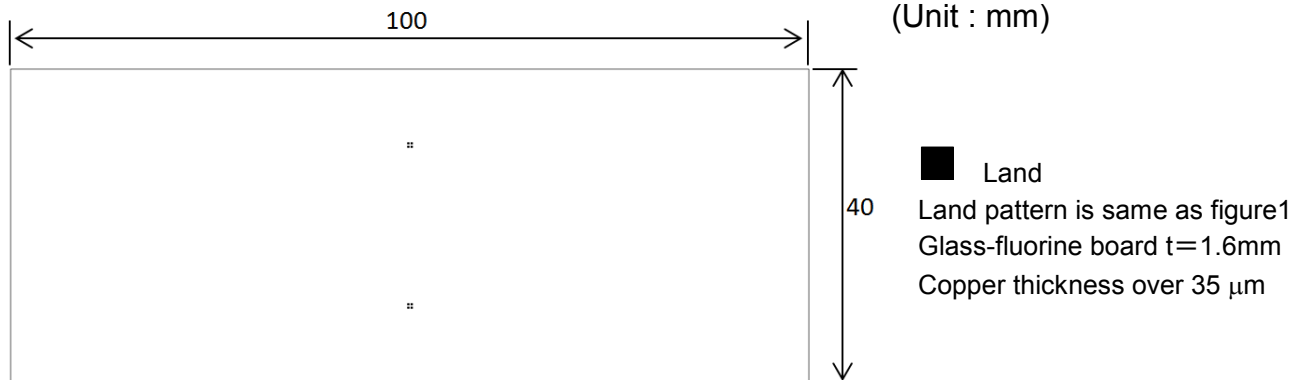

Mounted situation

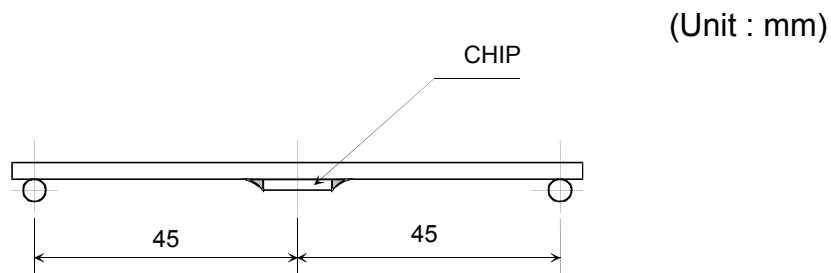

Test method

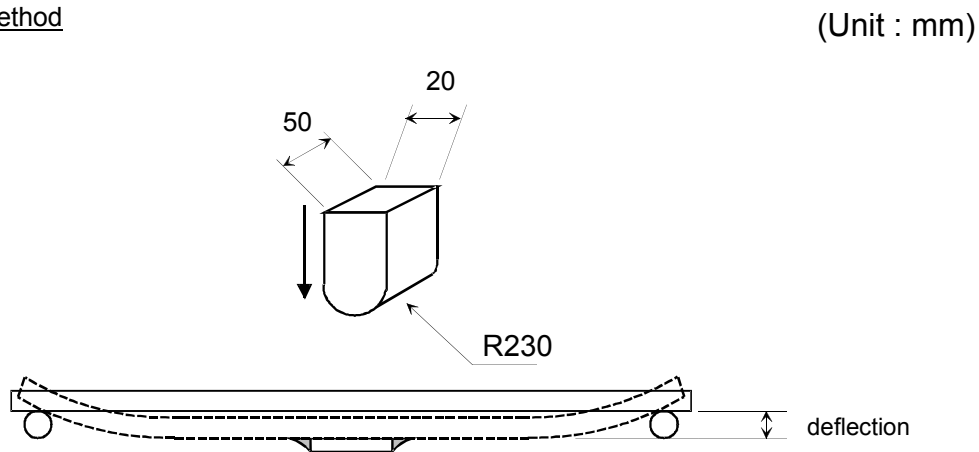

11. Tape and Reel Packing

11-1. Dimensions of Tape

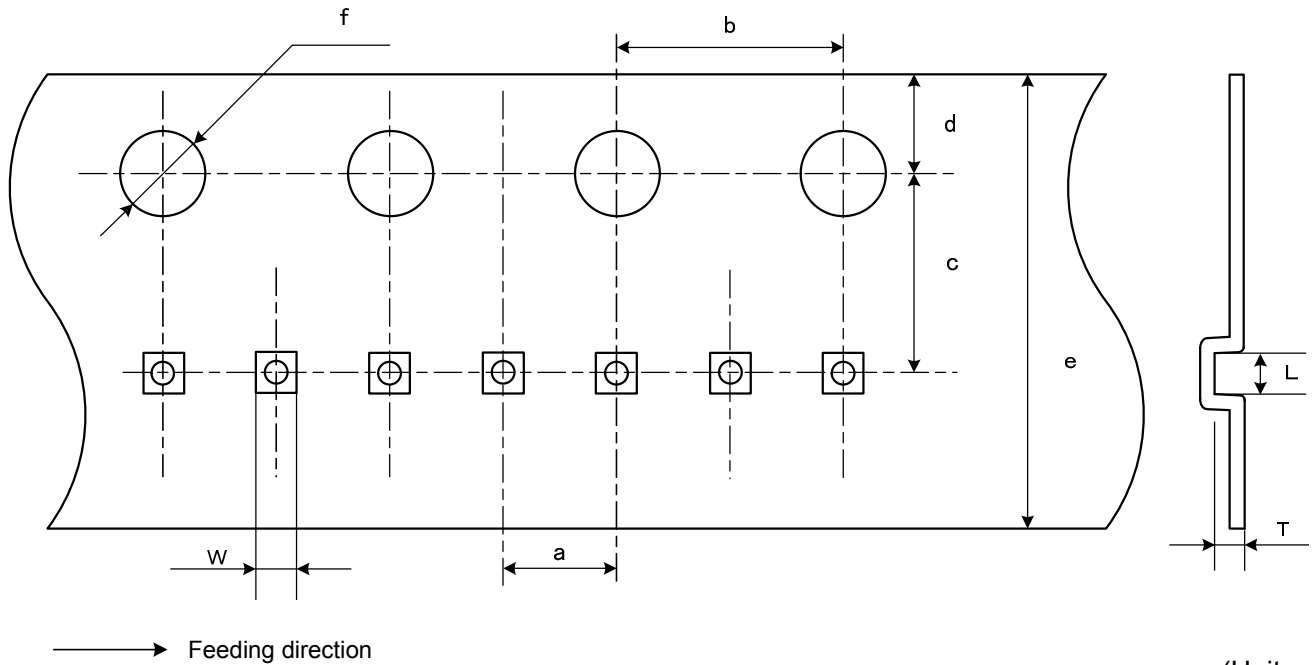

(Unit : mm)

Symbol	L	W	T	a	b	c	d	e	f
Size	0.68+/-0.03	0.68+/-0.03	0.33+/-0.03	2.0+/-0.05	4.0+/-0.1	(3.50)	1.75+/-0.1	8.0+/-0.2	φ1.5+/-0.1

11-2. Dimensions of Reel

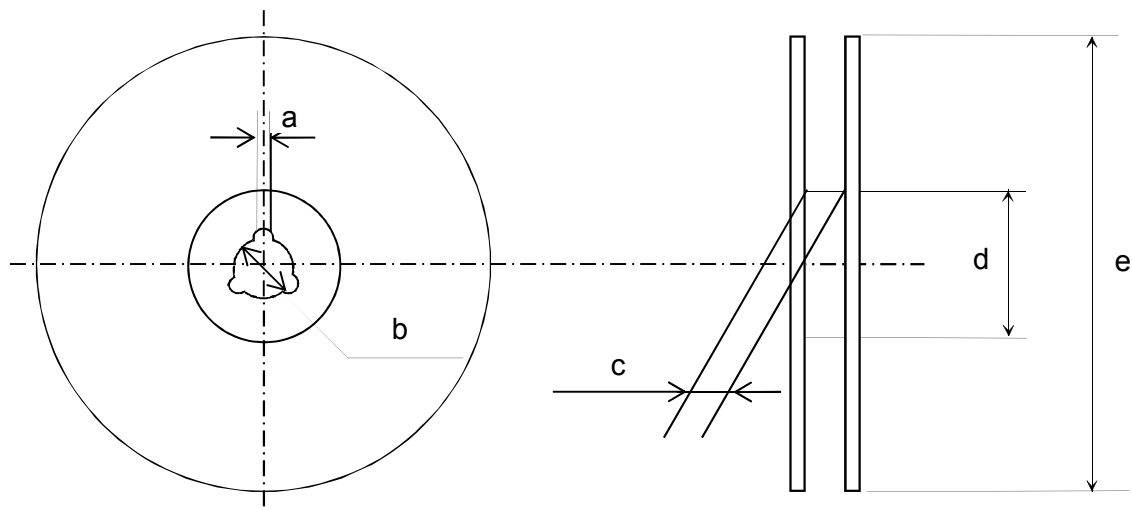

(Unit : mm)

Symbol	a	b	c	d	e
Size	1.5 min	φ13.0+/-0.2	(9.0)	φ60	φ180

11-3. Package Diagrams (Humidity proof Packing)

Tape and reel must be sealed with the anti-humidity plastic bag. The bag contains the desiccant and the humidity indicator.

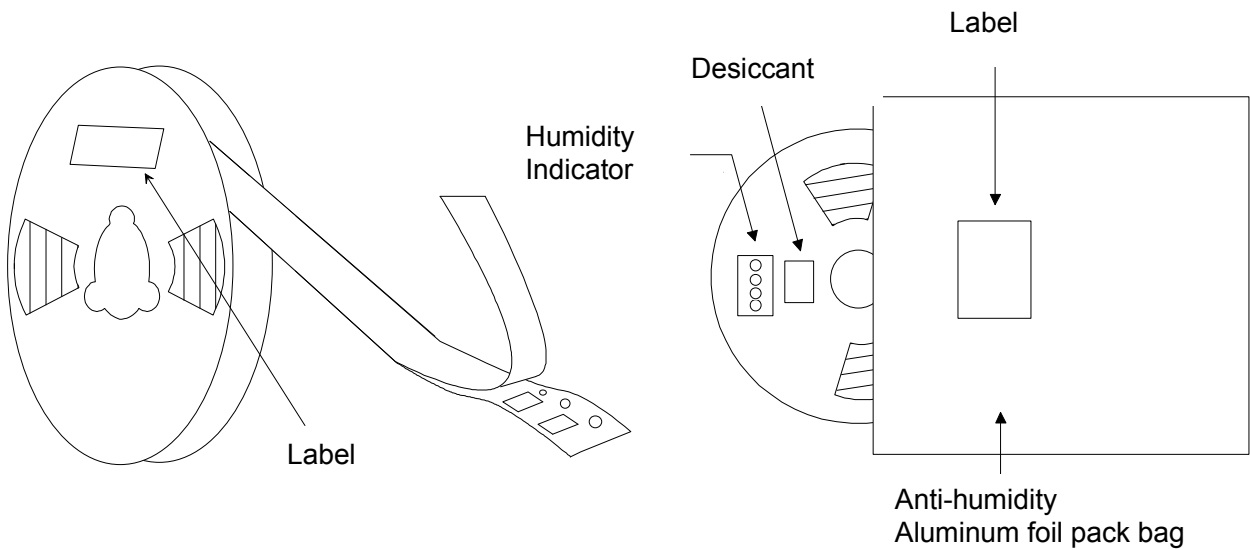

11-4. Taping Diagrams

- [1] Feeding Hole : As specified in (1)
- [2] Hole for chip : As specified in (1)
- [3] Cover tape : 50um in thickness
- [4] Base tape : As specified in (1)

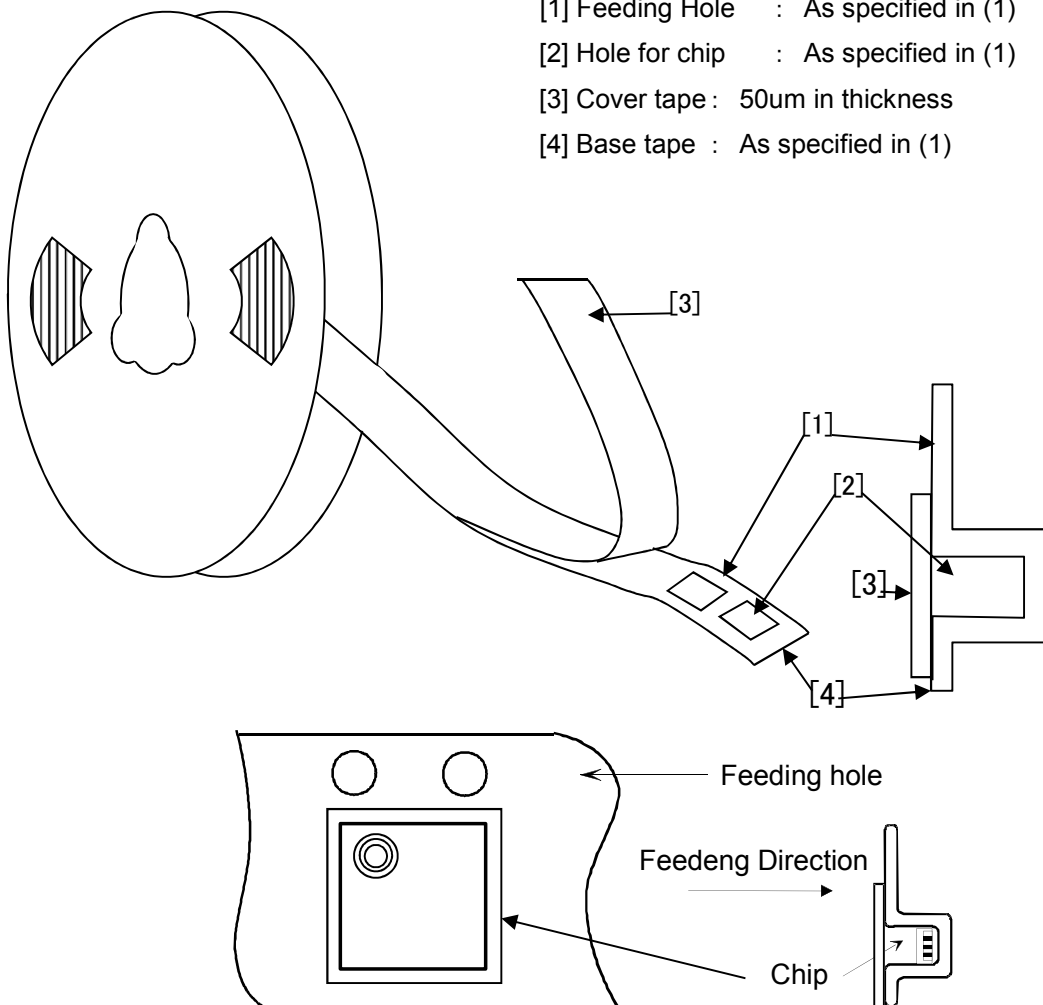

11-5. Leader and Tail tape

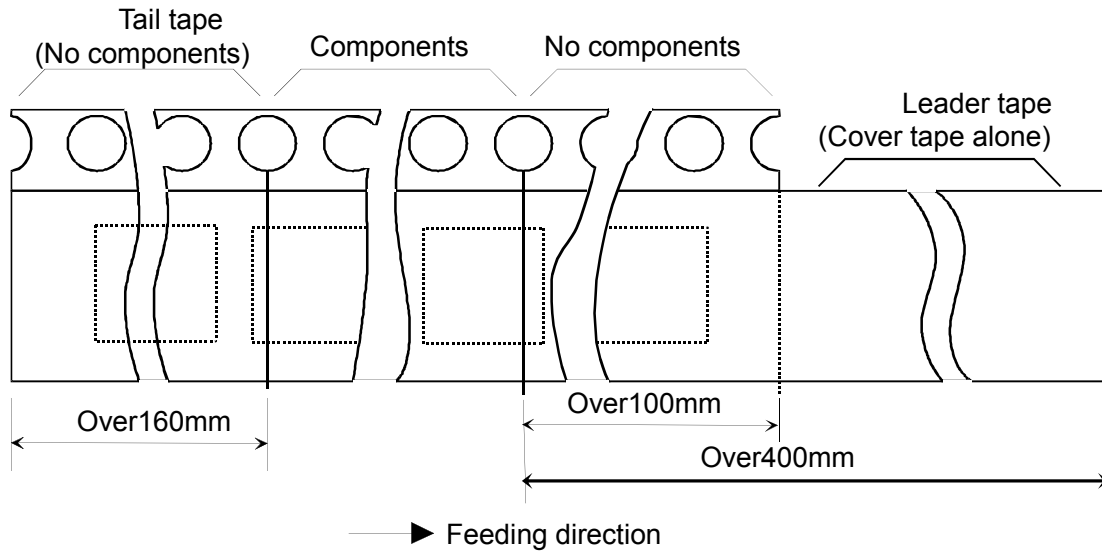

11-6. The tape for chips are wound clockwise, the feeding holes to the right side as the tape is pulled toward the user.

11-7. Packaging unit

10,000pcs./ reel

11-8. Material : Base tape Plastic
 Reel and Cover tapePlastic

Base tape, Reel and Cover tape have an anti-ESD function.

11-9. Peeling of force : 0.1~1.0 N in the direction of peeling as shown below.

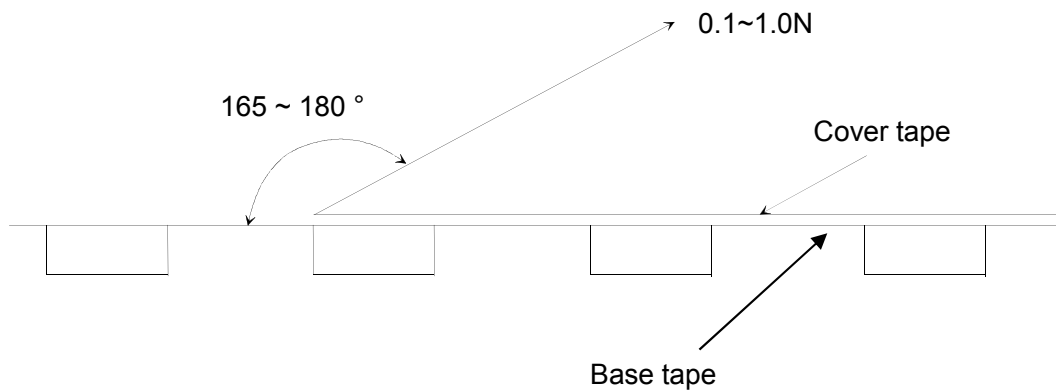

Notice

1. Storage Conditions:

- The product shall be stored without opening the packing under the ambient temperature from 5 to 35 deg.C and humidity from 20~70%RH.
(Packing materials, in particular, may be deformed at the temperature over 40 deg.C.)
- The product left more than 6 months after reception, it needs to be confirmed the solderability before used.
 - The product shall be stored in non corrosive gas (Cl₂, NH₃, SO₂, NO_x, etc.).
 - Any excess mechanical shock including, but not limited to, sticking the packing materials by sharp object and dropping the product, shall not be applied in order not to damage the packing materials.
- After the packing opened, the product shall be stored at ≤ 30 deg.C / ≤ 60 %RH and the product shall be used within 168 hours.

When the color of the indicator in the packing changed, the product shall be baked before soldering.

This product is applicable to MSL3 (Based on IPC/JEDEC J-STD-020)

2. Handling Conditions:

Be careful in handling or transporting products because excessive stress or mechanical shock may break products.

Handle with care if products may have cracks or damages on their terminals, the characteristics of products may change. Do not touch products with bare hands that may result in poor solderability.

3. Standard PCB Design (Land Pattern and Dimensions):

All the ground terminals should be connected to the ground patterns. Furthermore, the ground pattern should be provided between IN and OUT terminals. Please refer to the specifications for the standard land dimensions.

The recommended land pattern and dimensions is as Murata's standard. The characteristics of products may vary depending on the pattern drawing method, grounding method, land dimensions, land forming method of the NC terminals and the PCB material and thickness. Therefore, be sure to verify the characteristics in the actual set. When using non-standard lands, contact Murata beforehand.

4. Notice for Chip Placer:

When placing products on the PCB, products may be stressed and broken by uneven forces from a worn-out chucking locating claw or a suction nozzle. To prevent products from damages, be sure to follow the specifications for the maintenance of the chip placer being used. For the positioning of products on the PCB, be aware that mechanical chucking may damage products.

5. Soldering Conditions:

Carefully perform preheating so that the temperature difference (ΔT) between the solder and products surface should be in the following range. When products are immersed in solvent after mounting, pay special attention to maintain the temperature difference within 100 °C. Soldering must be carried out by the above mentioned conditions to prevent products from damage. Contact Murata before use if concerning other soldering conditions.

Reflow soldering standard conditions(Example)

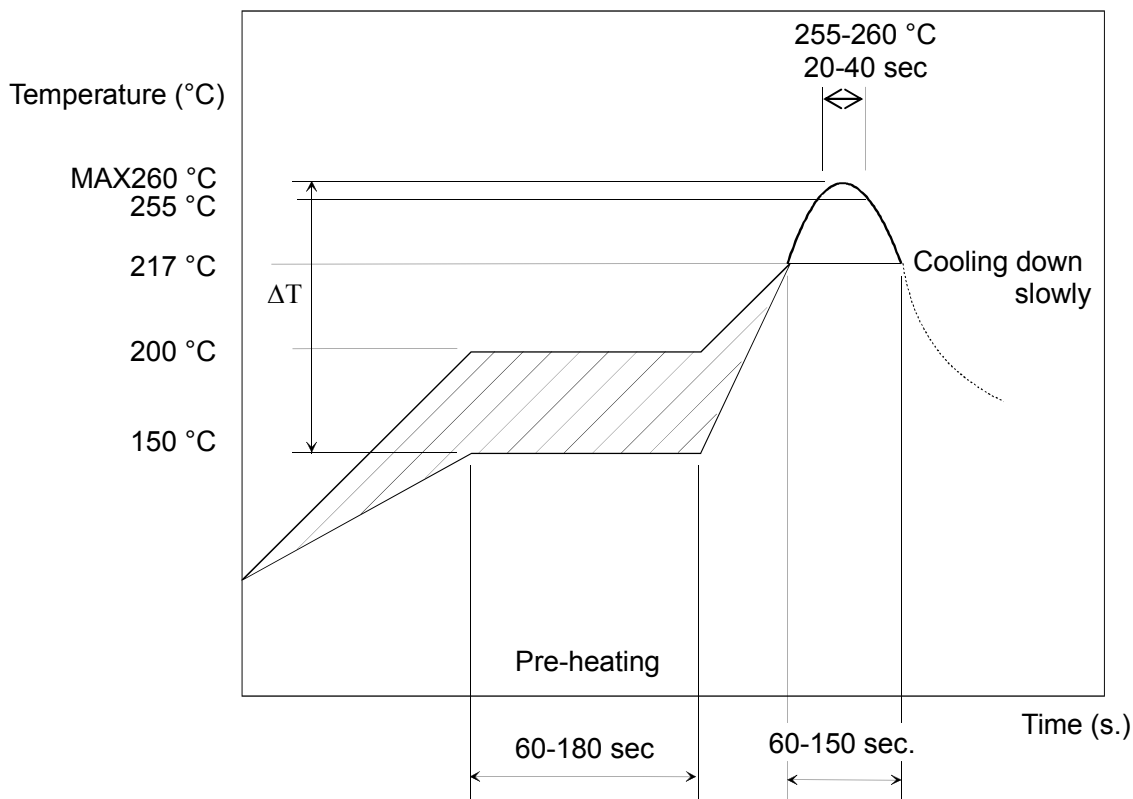

Atmosphere : N2

Use rosin type flux or weakly active flux with a chlorine content of 0.2 wt % or less

6. Cleaning Conditions:

Any cleaning is not permitted.

7. Operational Environment Conditions:

Products are designed to work for electronic products under normal environmental conditions (ambient temperature, humidity and pressure). Therefore, products have no problems to be used under the similar conditions to the above-mentioned. However, if products are used under the following circumstances, it may damage products and leakage of electricity and abnormal temperature may occur.

- In an atmosphere containing corrosive gas (Cl₂, NH₃, SO_x, NO_x etc.).
- In an atmosphere containing combustible and volatile gases.
- In a dusty environment.
- Direct sunlight
- Water splashing place.
- Humid place where water condenses.
- In a freezing environment.

If there are possibilities for products to be used under the preceding clause, consult with Murata before actual use.

If product malfunctions may result in serious damage, including that to human life, sufficient fail-safe measures must be taken, including the following:

- (1) Installation of protection circuits or other protective device to improve system safety
- (2) Installation of redundant circuits in the case of single-circuit failure

8. Limitation of Applications:

The products are designed and produced for application in ordinary electronic equipment (AV equipment, OA equipment, telecommunication, etc). If the products are to be used in devices requiring extremely high reliability following the application listed below, you should consult with the Murata staff in advance.

- Aircraft equipment.
- Aerospace equipment
- Undersea equipment.
- Power plant control equipment.
- Medical equipment.
- Transportation equipment (vehicles, trains, ships, etc.).
- Traffic signal equipment.
- Disaster prevention / crime prevention equipment.
- Data-processing equipment.
- Application which malfunction or operational error may endanger human life and property of assets.
- Application which related to occurrence the serious damage
- Application of similar complexity and/ or reliability requirements to the applications listed in the above.

 **Note:**

Please make sure that your product has been evaluated and confirmed against your specifications when our product is mounted to your product.

Product specifications are subject to change or our products in it may be discontinued without advance notice.

This catalog is for reference only and not an official product specification document, therefore, please review and approve our official product specification before ordering this product.

Mouser Electronics

Authorized Distributor



Click to View Pricing, Inventory, Delivery & Lifecycle Information:

[Murata:](#)

[LXRW0YV600-054](#)

Looking for pricing, stock, or lifecycle information?

Click below to explore more details on WIN SOURCE:

-  [View LXRW0YV600-054 on WIN SOURCE](#)
-  [Murata Electronics North America Information](#)

Optimize Your Supply Chain with WIN SOURCE Solutions

-  Global Sourcing Solution
-  Obsolete Management
-  Cost Control Management
-  Shortage Management
-  Alternative Solution
-  Excess Inventory Management