



**THE DATASHEET OF
LTC5598IUF**



5MHz to 1600MHz High Linearity Direct Quadrature Modulator

FEATURES

- **Frequency Range: 5MHz to 1600MHz**
- **High Output IP3: +27.7dBm at 140MHz
+22.9dBm at 900MHz**
- **Low Output Noise Floor at 6MHz Offset:**
 No Baseband AC Input: -161.2dBm/Hz
 $P_{OUT} = 5.5\text{dBm}$: -160dBm/Hz
- **Low LO Feedthrough: -55dBm at 140MHz**
- **High Image Rejection: -50.4dBc at 140MHz**
- **Integrated LO Buffer and LO Quadrature Phase Generator**
- **50Ω Single-Ended LO and RF Ports**
- **>400MHz Baseband Bandwidth**
- **24-Lead QFN 4mm × 4mm Package**
- **Pin-Compatible with Industry Standard Pin-Out**
- **Shut-down Mode**

APPLICATIONS

- Point-to-Point Microwave Link
- Military Radio
- Basestation Transmitter GSM/EDGE/CDMA2K
- 700MHz LTE Basestation Transmitter
- Satellite Communication
- CATV/Cable Broadband Modulator
- 13.56MHz/UHF RFID Modulator

DESCRIPTION

The LTC[®]5598 is a direct I/Q modulator designed for high performance wireless applications, including wireless infrastructure. It allows direct modulation of an RF signal using differential baseband I and Q signals. It supports point-to-point microwave link, GSM, EDGE, CDMA, 700MHz band LTE, CDMA2000, CATV applications and other systems. It may also be configured as an image reject upconverting mixer, by applying 90° phase-shifted signals to the I and Q inputs.

The I/Q baseband inputs consist of voltage-to-current converters that in turn drive double-balanced mixers. The outputs of these mixers are summed and applied to a buffer, which converts the differential mixer signals to a 50Ω single-ended buffered RF output. The four balanced I and Q baseband input ports are intended for DC coupling from a source with a common-mode voltage level of about 0.5V. The LO path consists of an LO buffer with single-ended or differential inputs, and precision quadrature generators that produce the LO drive for the mixers. The supply voltage range is 4.5V to 5.25V, with about 168mA current.

LT, LT, LTC and LTM are registered trademarks of Linear Technology Corporation. All other trademarks are the property of their respective owners.

TYPICAL APPLICATION

5MHz to 1600MHz Direct Conversion Transmitter Application

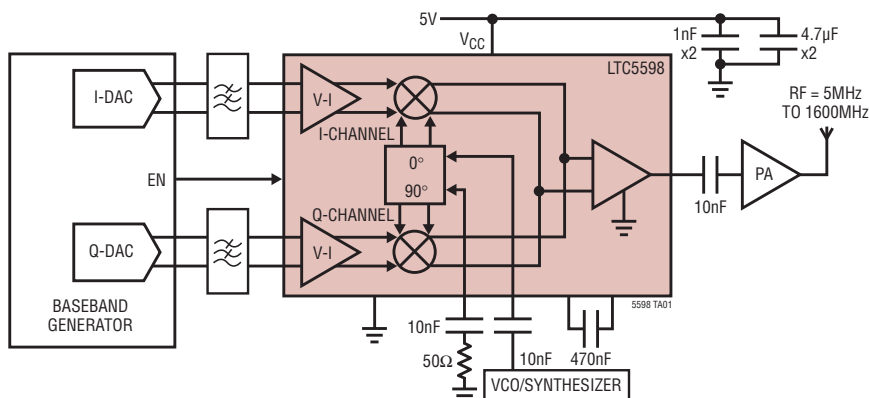

Noise Floor vs RF Output Power and Differential LO Input Power

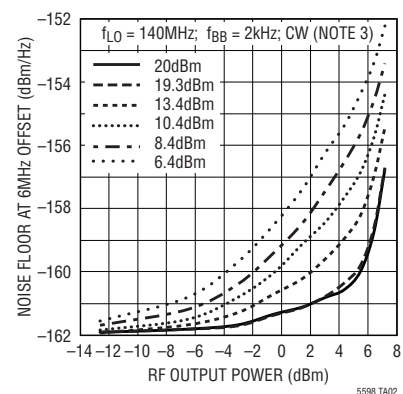

ABSOLUTE MAXIMUM RATINGS

(Note 1)

Supply Voltage	5.6V
Common Mode Level of BBPI, BBMI and BBPQ, BBMQ	0.6V
LOP, LOM Input	20dBm
Voltage on Any Pin Not to Exceed	-0.3V to $V_{CC} + 0.3V$
T_{JMAX}	150°C
Operating Temperature Range	-40°C to 85°C
Storage Temperature Range	-65°C to 150°C

PIN CONFIGURATION

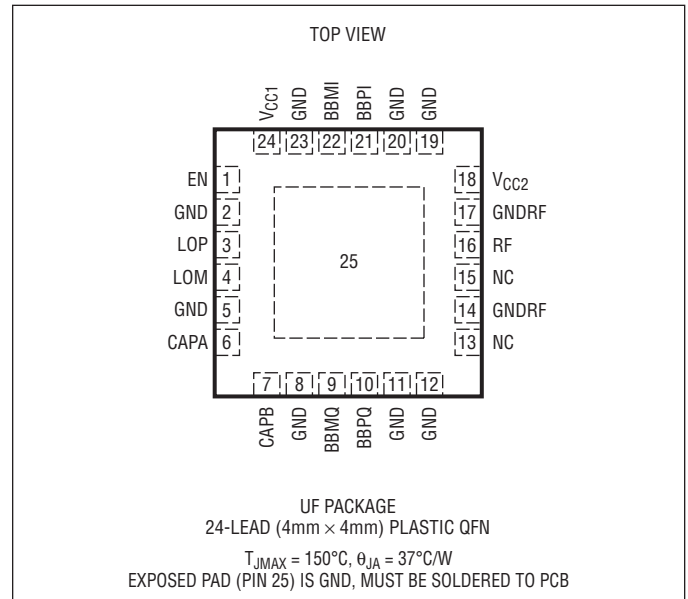

ORDER INFORMATION

LEAD FREE FINISH	TAPE AND REEL	PART MARKING	PACKAGE DESCRIPTION	TEMPERATURE RANGE
LTC5598IUF#PBF	LTC5598IUF#TRPBF	5598	24-Lead (4mm × 4mm) Plastic QFN	-40°C to 85°C

Consult LTC Marketing for parts specified with wider operating temperature ranges.

Consult LTC Marketing for information on non-standard lead based finish parts.

For more information on lead free part marking, go to: <http://www.linear.com/leadfree/>

For more information on tape and reel specifications, go to: <http://www.linear.com/tapeandreeel/>

ELECTRICAL CHARACTERISTICS

$V_{CC} = 5V$, $EN = 5V$, $T_A = 25^\circ C$, $P_{LO} = 0dBm$, single-ended; BBPI, BBMI, BBPQ, BBMQ common-mode DC voltage $V_{CMBB} = 0.5V_{DC}$, I&Q baseband input signal = 100kHz CW, 0.8V_{PP,DIFF} each, I&Q 90° shifted (lower side-band selection), unless otherwise noted. (Note 11)

SYMBOL	PARAMETER	CONDITIONS	MIN	TYP	MAX	UNITS
RF OUTPUT (RF)						
f_{RF}	RF Frequency Range			5 to 1600		MHz
$S_{22, ON}$	RF Output Return Loss	EN = High, 5MHz to 1600MHz		< -20		dB
$f_{LO} = 140MHz$, $f_{RF} = 139.9MHz$						
G_V	Conversion Voltage Gain	$20 \cdot \text{Log}(V_{RF, OUT, 50\Omega}/V_{IN, DIFF, I \text{ or } Q})$		-2		dB
P_{OUT}	Absolute Output Power	1V _{PP,DIFF} on each I&Q Inputs		2		dBm
OP1dB	Output 1dB Compression			8.5		dBm
OIP2	Output 2nd Order Intercept	(Notes 4, 5)		74		dBm
OIP3	Output 3rd Order Intercept	(Notes 4, 6)		27.7		dBm
NFloor	RF Output Noise Floor	No Baseband AC Input Signal (Note 3) $P_{OUT} = 4.6dBm$ (Note 3) $P_{LO, SE} = 10dBm$ $P_{OUT} = 5.5dBm$ (Note 3) $P_{LO, DIFF} = 20dBm$		-161.2 -154.5 -160		dBm/Hz dBm/Hz dBm/Hz
IR	Image Rejection	(Note 7)		-50.4		dBc
LOFT	LO Feedthrough (Carrier Leakage)	EN = High (Note 7) EN = Low (Note 7)		-55 -78		dBm dBm
$f_{LO} = 450MHz$, $f_{RF} = 449.9MHz$						
G_V	Conversion Voltage Gain	$20 \cdot \text{Log}(V_{RF, OUT, 50\Omega}/V_{IN, DIFF, I \text{ or } Q})$	-5.0	-2.1	0.5	dB
P_{OUT}	Absolute Output Power	1V _{PP,DIFF} on each I&Q Inputs		1.9		dBm
OP1dB	Output 1dB Compression			8.4		dBm
OIP2	Output 2nd Order Intercept	(Notes 4, 5)		72		dBm
OIP3	Output 3rd Order Intercept	(Notes 4, 6)		25.5		dBm
NFloor	RF Output Noise Floor	No Baseband AC Input Signal (Note 3)		-160.9		dBm/Hz
IR	Image Rejection	(Note 7)		-55		dBc
LOFT	LO Feedthrough (Carrier Leakage)	EN = High (Note 7) EN = Low (Note 7)		-51 -68		dBm dBm
$f_{LO} = 900MHz$, $f_{RF} = 899.9MHz$						
G_V	Conversion Voltage Gain	$20 \cdot \text{Log}(V_{RF, OUT, 50\Omega}/V_{IN, DIFF, I \text{ or } Q})$		-2		dB
P_{OUT}	Absolute Output Power	1V _{PP,DIFF} on each I&Q Inputs		2		dBm
OP1dB	Output 1dB Compression			8.5		dBm
OIP2	Output 2nd Order Intercept	(Notes 4, 5)		69		dBm
OIP3	Output 3rd Order Intercept	(Notes 4, 6)		22.9		dBm
NFloor	RF Output Noise Floor	No Baseband AC Input Signal (Note 3) $P_{OUT} = 5.2dBm$ (Note 3) $P_{LO, SE} = 10dBm$		-160.3 -154.5		dBm/Hz dBm/Hz
IR	Image Rejection	(Note 7)		-54		dBc
LOFT	LO Feedthrough (Carrier Leakage)	EN = High (Note 7) EN = Low (Note 7)		-48 -54		dBm dBm

ELECTRICAL CHARACTERISTICS

$V_{CC} = 5V$, $EN = 5V$, $T_A = 25^\circ C$, $P_{LO} = 0dBm$, single-ended; BBPI, BBMI, BBPQ, BBMQ common-mode DC voltage $V_{CMBB} = 0.5V_{DC}$, I&Q baseband input signal = 100kHz CW, $0.8V_{PP,DIFF}$ each, I&Q 90° shifted (lower side-band selection), unless otherwise noted. (Note 11)

SYMBOL	PARAMETER	CONDITIONS	MIN	TYP	MAX	UNITS
LO INPUT (LOP)						
f_{LO}	LO Frequency Range			5 to 1600		MHz
$P_{LO,DIFF}$	Differential LO Input Power Range			-10 to 20		dBm
$P_{LO,SE}$	Single-Ended LO Input Power Range			-10 to 12		dBm
$S_{11,ON}$	LO Input Return Loss	EN = High		-10.5		dB
$S_{11,OFF}$	LO Input Return Loss	EN = Low		-9.6		dB
BASEBAND INPUTS (BBPI, BBMI, BBPQ, BBMQ)						
BW_{BB}	Baseband Bandwidth	-3dB Bandwidth		>400		MHz
$I_{b,BB}$	Baseband Input Current	Single-Ended		-68		μA
$R_{IN,SE}$	Input Resistance	Single-Ended		-7.4		k Ω
V_{CMBB}	DC Common-Mode Voltage	Externally Applied		0.5		V
V_{SWING}	Amplitude Swing	No Hard Clipping, Single-Ended		0.86		V_{P-P}
POWER SUPPLY (V_{CC1}, V_{CC2})						
V_{CC}	Supply Voltage		4.5	5	5.25	V
$I_{CC(ON)}$	Supply Current	EN = High, $I_{CC1} + I_{CC2}$	130	165	200	mA
$I_{CC(OFF)}$	Supply Current, Sleep Mode	EN = 0V, $I_{CC1} + I_{CC2}$		0.24	0.9	mA
t_{ON}	Turn-On Time	EN = Low to High (Notes 8, 10)		75		ns
t_{OFF}	Turn-Off Time	EN = High to Low (Notes 9, 10)		10		ns
POWER UP/DOWN						
Enable	Input High Voltage Input High Current	EN = High EN = 5V	2	43		V μA
Sleep	Input Low Voltage Input Low Current	EN = Low EN = 0V		-40	1	V μA

Note 1: Stresses beyond those listed under Absolute Maximum Ratings may cause permanent damage to the device. Exposure to any Absolute Maximum Rating condition for extended periods may affect device reliability and lifetime.

Note 2: The LTC5598 is guaranteed functional over the operating temperature range $-40^\circ C$ to $85^\circ C$.

Note 3: At 6MHz offset from the LO signal frequency. 100nF between BBPI and BBMI, 100nF between BBPQ and BBMQ.

Note 4: Baseband is driven by 2MHz and 2.1MHz tones with $1V_{PP,DIFF}$ for two-tone signals at each I or Q input ($0.5V_{PP,DIFF}$ for each tone).

Note 5: IM2 is measured at LO frequency $-4.1MHz$.

Note 6: IM3 is measured at LO frequency $-1.9MHz$ and LO frequency $-2.2MHz$.

Note 7: Amplitude average of the characterization data set without image or LO feedthrough nulling (unadjusted).

Note 8: RF power is within 10% of final value.

Note 9: RF power is at least 30dB lower than in the ON state.

Note 10: External coupling capacitors at pins LOP, LOM and RF are 100pF each.

Note 11: Tests are performed as shown in the configuration of Figure 10. The LO power is applied to J3 while J5 is terminated with 50Ω to ground for single-ended LO drive.

TYPICAL PERFORMANCE CHARACTERISTICS $V_{CC} = 5V$, $EN = 5V$, $T_A = 25^\circ C$, $f_{RF} = f_{LO} - f_{BB}$, $P_{LO} = 0dBm$ single-ended, BBPI, BBMI, BBPQ, BBMQ common-mode DC voltage $V_{CMBB} = 0.5V_{DC}$, I&Q baseband input signal = 100kHz, 0.8V_{PP,DIFF}, two-tone baseband input signal = 2MHz, 2.1MHz, 0.5V_{PP,DIFF} each tone, I&Q 90° shifted (lower side-band selection); $f_{NOISE} = f_{LO} - 6MHz$; unless otherwise noted. (Note 11)

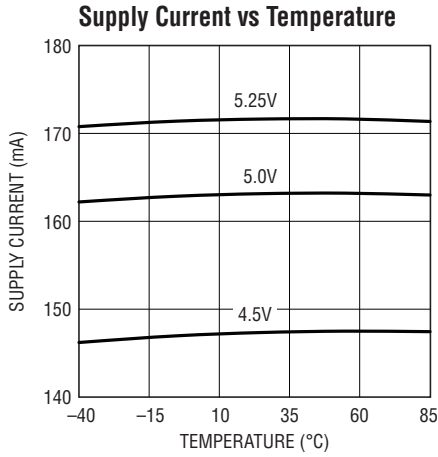

5598 G01

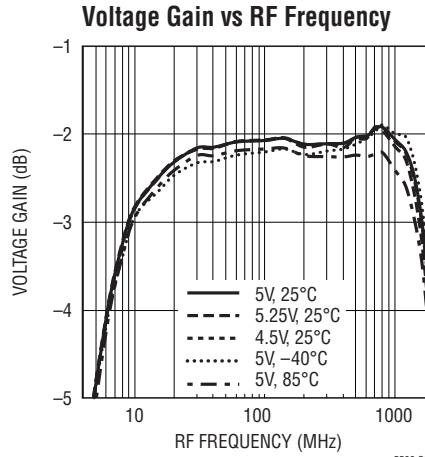

5598 G02

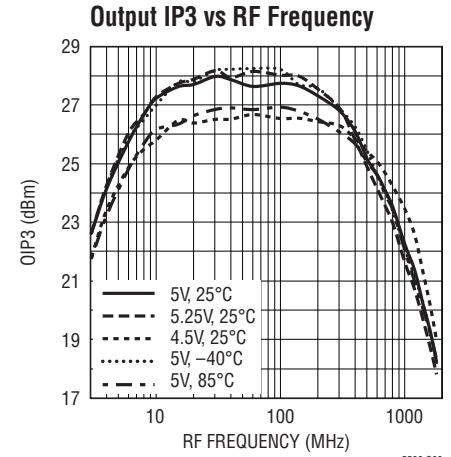

5598 G03

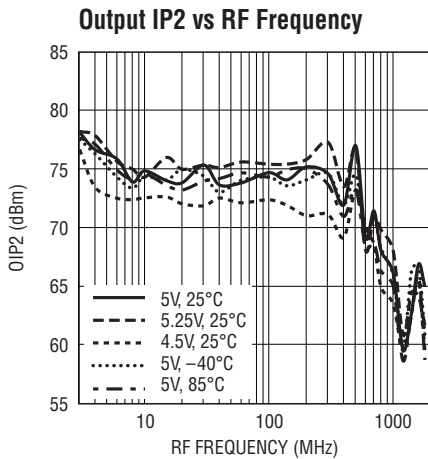

5598 G04

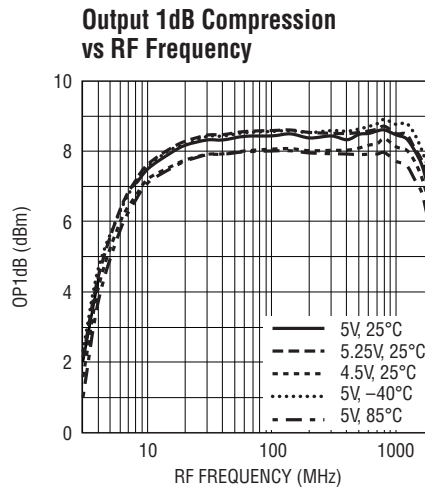

5598 G05

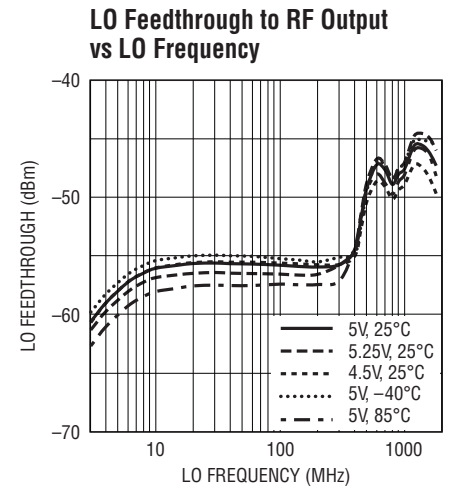

5598 G06

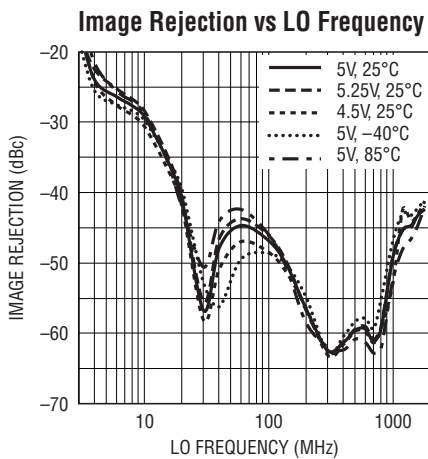

5598 G07

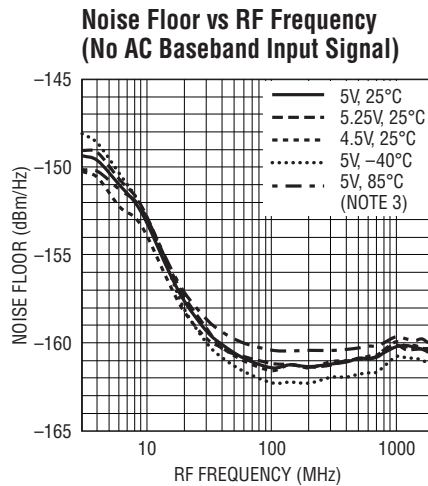

5598 G08

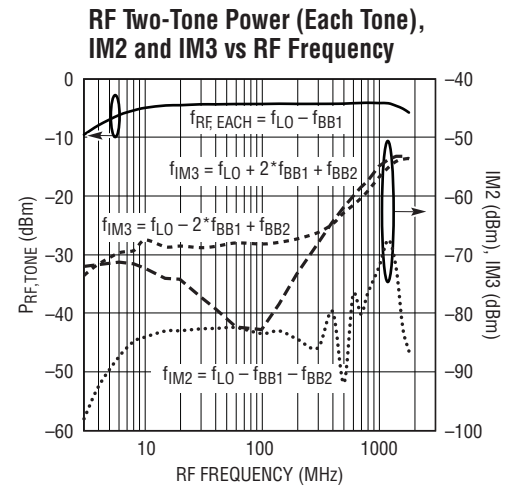

5598 G09

TYPICAL PERFORMANCE CHARACTERISTICS $V_{CC} = 5V$, $EN = 5V$, $T_A = 25^\circ C$, $f_{RF} = f_{LO} - f_{BB}$, $P_{LO} = 0dBm$ single-ended, BBP1, BBMI, BBPQ, BBMQ common-mode DC voltage $V_{CMBB} = 0.5V_{DC}$, I&Q baseband input signal = 100kHz, $0.8V_{PP,DIFF}$, two-tone baseband input signal = 2MHz, 2.1MHz, $0.5V_{PP,DIFF}$ each tone, I&Q 90° shifted (lower side-band selection); $f_{NOISE} = f_{LO} - 6MHz$; unless otherwise noted. (Note 11)

RF Two-Tone Power (Each Tone), IM2 and IM3 vs Baseband Voltage and Temperature ($f_{LO} = 140MHz$)

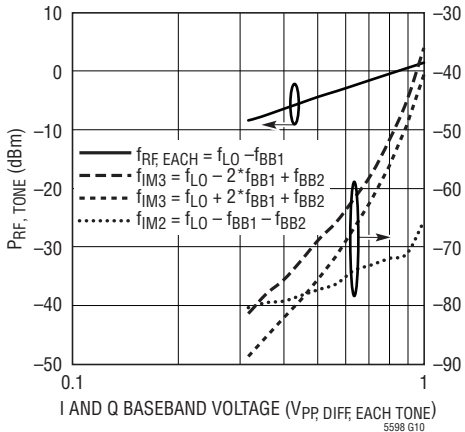

RF Two-Tone Power (Each Tone), IM2 and IM3 vs Baseband Voltage and Temperature ($f_{LO} = 900MHz$)

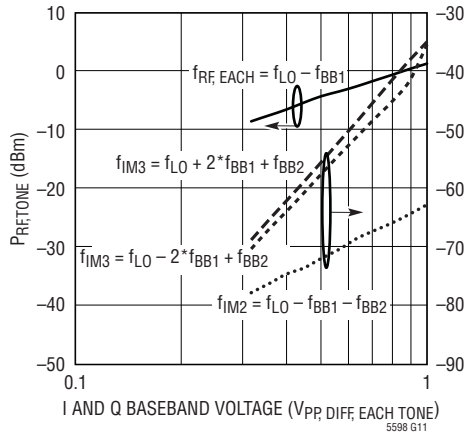

Voltage Gain vs RF Frequency ($P_{LO} = 10dBm$)

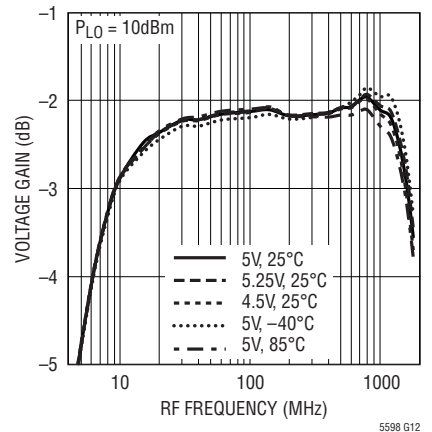

Output IP3 vs RF Frequency ($P_{LO} = 10dBm$)

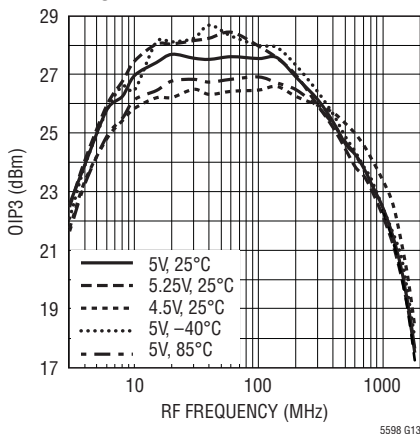

Output IP2 vs RF Frequency ($P_{LO} = 10dBm$)

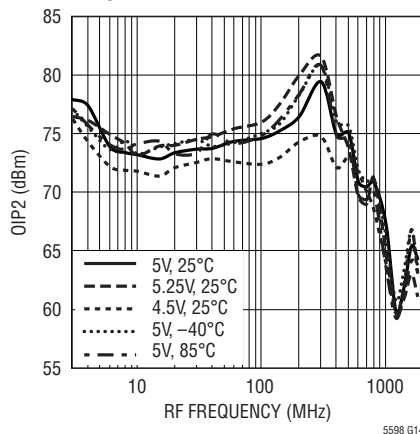

Output 1dB Compression vs RF Frequency ($P_{LO} = 10dBm$)

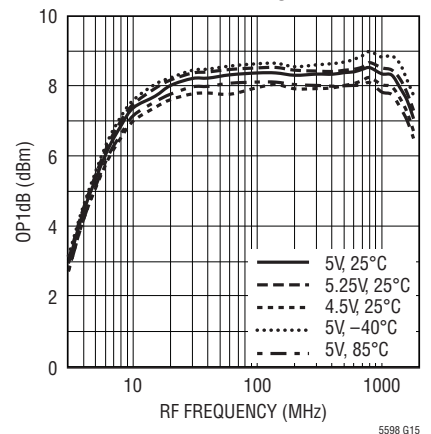

LO Feedthrough to RF Output vs LO Frequency ($P_{LO} = 10dBm$)

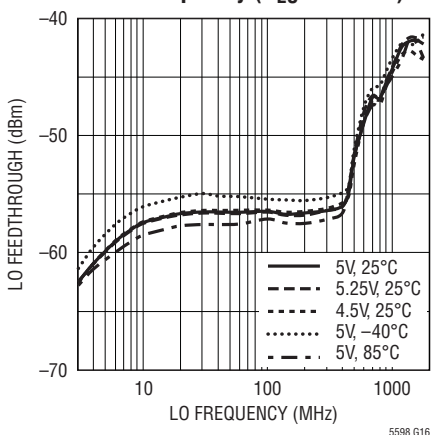
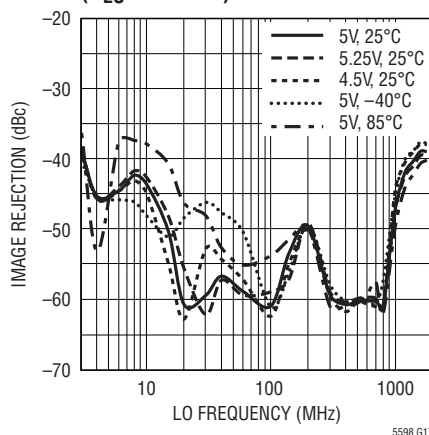
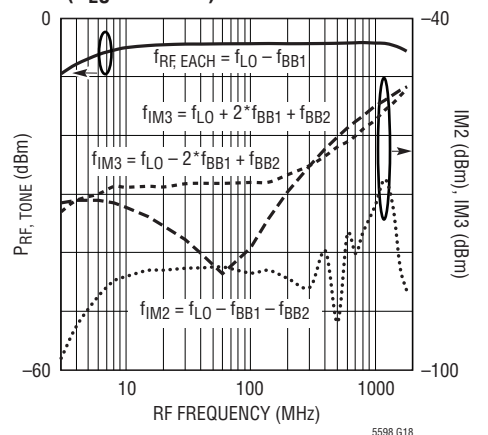

Image Rejection vs LO Frequency ($P_{LO} = 10dBm$)



RF Two-Tone Power (Each Tone), IM2 and IM3 vs RF Frequency ($P_{LO} = 10dBm$)



TYPICAL PERFORMANCE CHARACTERISTICS $V_{CC} = 5V$, $EN = 5V$, $T_A = 25^\circ C$, $f_{RF} = f_{LO} - f_{BB}$, $f_{LO} = 450MHz$, $P_{LO} = 0dBm$ single-ended, BBPI, BBMI, BBPQ, BBMQ common-mode DC voltage $V_{CMDBB} = 0.5V_{DC}$, I&Q baseband input signal = 100kHz, 0.8V_{PP,DIFF}, two-tone baseband input signal = 2MHz, 2.1MHz, 0.5V_{PP,DIFF} each tone, I&Q 90° shifted (lower side-band selection); $f_{NOISE} = f_{LO} - 6MHz$; unless otherwise noted. (Note 11)

Noise Floor vs RF Frequency
($P_{LO} = 10dBm$, No AC Baseband Input Signal)

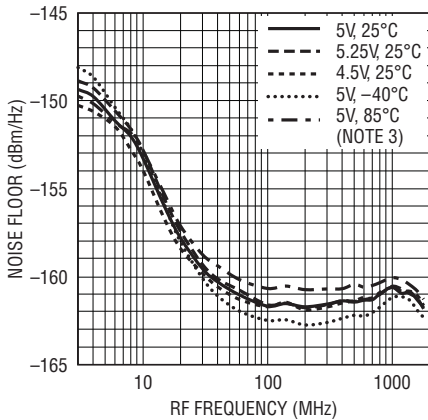

5598 G19

LO Feedthrough to RF Output vs LO Frequency for EN = Low

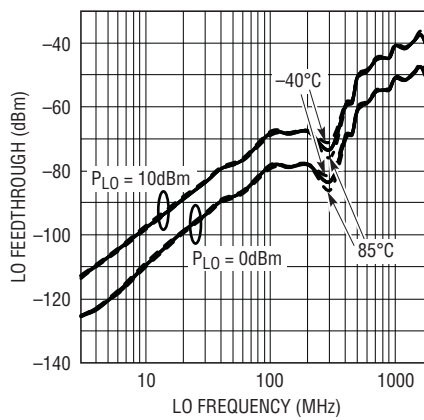

5598 G20

Image Rejection vs LO Frequency
($P_{LO} = 10dBm$)

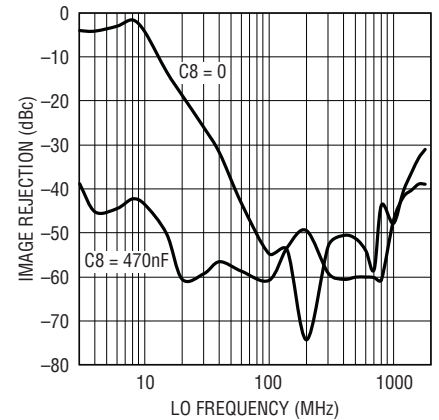

5598 G20a

Noise Floor vs RF Output Power and Differential LO Input Power

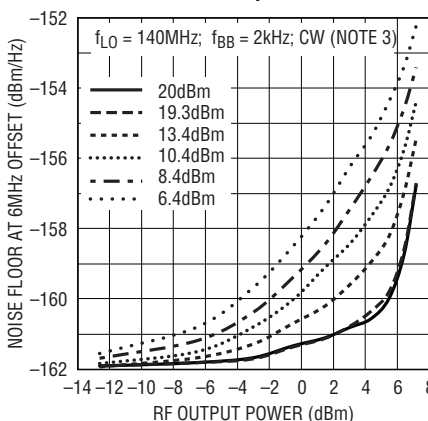

5598 G20b

Gain Distribution

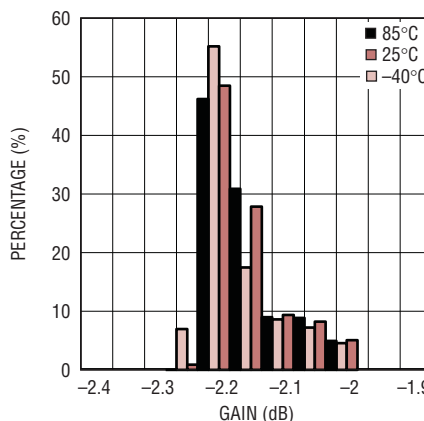

5598 G21

Output IP3 Distribution at 25°C

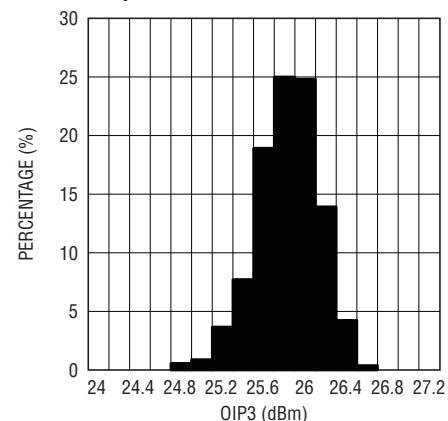

5598 G22

LO Feedthrough Distribution

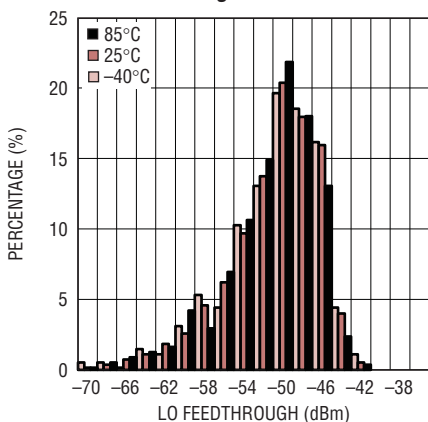

5598 G23

Image Rejection Distribution

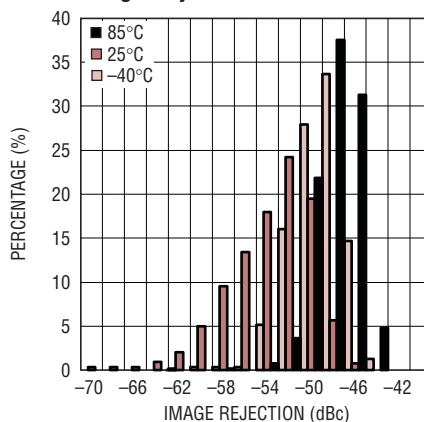

5598 G24

Noise Floor Distribution

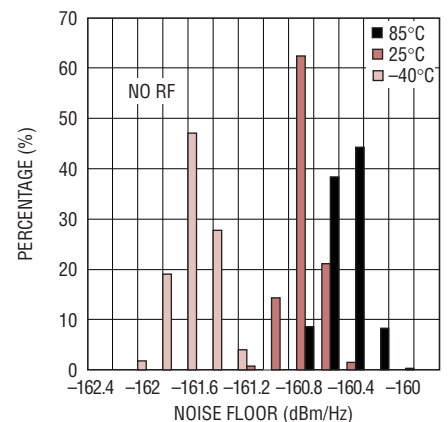

5598 G25

5598f

PIN FUNCTIONS

EN (Pin 1): Enable Input. When the Enable Pin voltage is higher than 2 V, the IC is turned on. When the input voltage is less than 1 V, the IC is turned off. If not connected, the IC is enabled.

GND (Pins 2, 5, 8, 11, 12, 19, 20, 23 and 25): Ground. Pins 2, 5, 8, 11, 12, 19, 20, 23 and exposed pad 25 are connected to each other internally. For best RF performance, pins 2, 5, 8, 11, 12, 19, 20, 23 and the Exposed Pad 25 should be connected to RF ground.

LOP (Pin 3): Positive LO Input. This LO input is internally biased at about 2.3V. An AC de-coupling capacitor should be used at this pin to match to an external 50Ω source.

LOM (Pin 4): Negative LO Input. This input is internally biased at about 2.3V. An AC de-coupling capacitor should be used at this pin via a 50Ω to ground for best OIP2 performance.

CAPA, CAPB (Pins 6, 7): External capacitor pins. A capacitor between the CAPA and the CAPB pin can be used in order to improve the image rejection for frequencies below 100MHz. A capacitor value of 470nF is recommended. These pins are internally biased at about 2.3V.

BBMQ, BBPQ (Pins 9, 10): Baseband Inputs for the Q-channel, each high input impedance. They should be externally biased at 0.5V common-mode level and not be left floating. Applied common-mode voltage must stay below 0.6V_{DC}.

NC (Pins 13, 15): No Connect. These pins are floating.

GNDRF (Pins 14, 17): Ground. Pins 14 and 17 are connected to each other internally and function as the ground return for the RF output buffer. They are connected via back-to-back diodes to the exposed pad 25. For best LO suppression performance those pins should be grounded separately from the exposed paddle 25. For best RF performance, pins 14 and 17 should be connected to RF ground.

RF (Pin 16): RF Output. The RF output is a DC-coupled single-ended output with approximately 50Ω output impedance at RF frequencies. An AC coupling capacitor should be used at this pin to connect to an external load.

V_{CC} (Pins 18, 24): Power Supply. It is recommended to use 1nF and 4.7μF capacitors for decoupling to ground on each of these pins.

BBPI, BBMI (Pins 21, 22): Baseband Inputs for the I-channel, each high input impedance. They should be externally biased at 0.5V common-mode level and not be left floating. Applied common-mode voltage must stay below 0.6V_{DC}.

Exposed Pad (Pin 25): Ground. This pin must be soldered to the printed circuit board ground plane.

BLOCK DIAGRAM

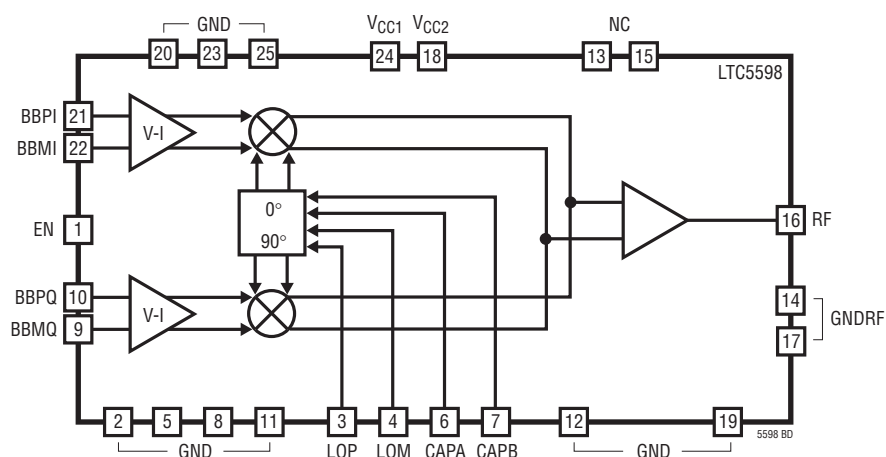

APPLICATIONS INFORMATION

The LTC5598 consists of I and Q input differential voltage-to-current converters, I and Q up-conversion mixers, an RF output buffer, an LO quadrature phase generator and LO buffers.

External I and Q baseband signals are applied to the differential baseband input pins, BBPI, BBMI, and BBPQ, BBMQ. These voltage signals are converted to currents and translated to RF frequency by means of double-balanced up-converting mixers. The mixer outputs are combined in an RF output buffer, which also transforms the output impedance to 50Ω . The center frequency of the resulting RF signal is equal to the LO signal frequency. The LO input drives a phase shifter which splits the LO signal into in-phase and quadrature LO signals. These LO signals are then applied to on-chip buffers which drive the up-conversion mixers. In most applications, the LOP input is driven by the LO source via an optional matching network, while the LOM input is terminated with 50Ω to RF ground via a similar optional matching network. The RF output is single-ended and internally 50Ω matched.

Baseband Interface

The circuit is optimized for a common mode voltage of $0.5V$ which should be externally applied. The baseband pins should not be left floating because the internal PNP's base current will pull the common mode voltage higher than the $0.6V$ limit. This condition may damage the part. In shut-down mode, it is recommended to have a termination to ground or to a $0.5V$ source with a value lower than $1k\Omega$. The PNP's base current is about $-68\mu A$ in normal operation.

The baseband inputs (BBPI, BBMI, BBPQ, BBMQ) present a single-ended input impedance of about $-7.4k\Omega$ each. Because of the negative input impedance, it is important to keep the source resistance at each baseband input low enough such that the parallel value remains positive vs baseband frequency. At each of the four baseband inputs, a capacitor of $4pF$ in series with 30Ω is connected to ground. This is in parallel with a PNP emitter follower (see Figure 1). The baseband bandwidth depends on the source impedance. For a 25Ω source impedance, the baseband bandwidth ($-1dB$) is about $300MHz$. If a $5.6nH$ series inductor is

inserted in each of the four baseband connections, the $-1dB$ baseband bandwidth increases to about $800MHz$.

It is recommended to include the baseband input impedance in the baseband lowpass filter design. The input impedance of each baseband input is given in Table 1.

Table 1. Single-Ended BB Port Input Impedance vs Frequency for EN = High and $V_{CMBB} = 0.5V_{DC}$

FREQUENCY (MHz)	BB INPUT IMPEDANCE	REFLECTION COEFFICIENT	
		MAG	ANGLE
0.1	$-10578 - j263$	1.01	-0.02
1	$-8436 - j1930$	1.011	-0.15
2	$-6340 - j3143$	1.013	-0.36
4	$-3672 - j3712$	1.014	-0.78
8	$-1644 - j2833$	1.015	-1.51
16	$-527 - j1765$	1.016	-2.98
30	$-177 - j1015$	1.017	-5.48
60	$-45.2 - j514$	1.017	-11
100	$-13.2 - j306$	1.014	-18.5
140	$-0.2 - j219$	1	-25.7
200	$4.5 - j151$	0.982	-36.6
300	$10.4 - j99.4$	0.921	-52.9
400	$12.3 - j72.4$	0.854	-68.2
500	$14.7 - j57.5$	0.780	-79.9
600	$15.5 - j46.3$	0.720	-91.4

The baseband inputs should be driven differentially; otherwise, the even-order distortion products may degrade the overall linearity performance. Typically, a DAC will

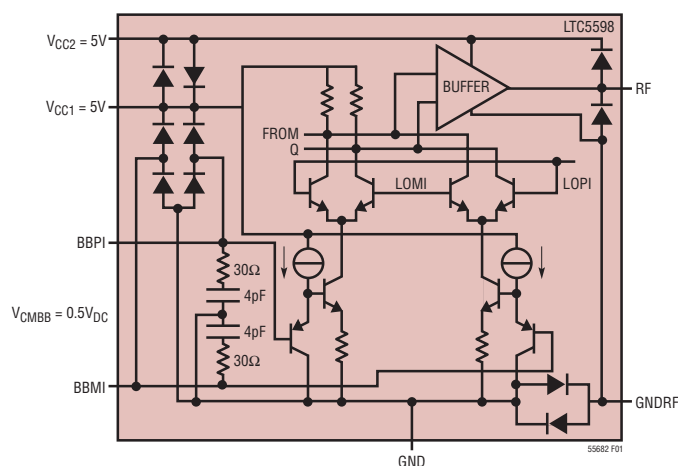

Figure 1. Simplified Circuit Schematic of the LTC5598 (Only I-Half is Drawn)

APPLICATIONS INFORMATION

be the signal source for the LTC5598. A reconstruction filter should be placed between the DAC output and the LTC5598's baseband inputs.

In Figure 2 a typical baseband interface is shown, using a fifth-order lowpass ladder filter.

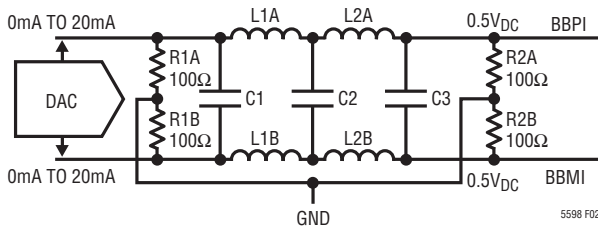

Figure 2. Baseband Interface with 5th Order Filter and 0.5V_{CM} DAC (Only I Channel is Shown)

For each baseband pin, a 0 to 1V swing is developed corresponding to a DAC output current of 0mA to 20mA. The maximum sinusoidal single side-band RF output power is about +7.3dBm for full 0V to 1V swing on each I- and Q- channel baseband input (2V_{PP, DIFF}).

LO Section

The internal LO chain consists of poly-phase phase shifters followed by LO buffers. The LOP input is designed as a single-ended input with about 50Ω input impedance. The LOM input should be terminated with 50Ω through a DC blocking capacitor.

The LOP and LOM inputs can be driven differentially in case an exceptionally low large-signal output noise floor is required (see graph 5598 G20b).

A simplified circuit schematic for the LOP, LOM, CAPA and CAPB inputs is given in Figure 3. A feedback path is implemented from the LO buffer outputs to the LO inputs in order to minimize offsets in the LO chain by storing the offsets on C5, C7 and C8 (see Figure 10). Optional capacitor C8 improves the image rejection below 100MHz (see graph 5598 G20a). Because of the feedback path, the input impedance for P_{LO} = 0dBm is somewhat different than for P_{LO} = 10dBm for the lower part of the operating frequency range. In Table 2, the LOP port input impedance vs frequency is given for EN = High and P_{LO} = 0dBm. For EN = Low and P_{LO} = 0dBm, the input impedance is given

in Table 3. In Table 4 and 5, the LOP port input impedance is given for EN = High and Low under the condition of P_{LO} = 10dBm. Figure 4 shows the LOP port return loss for the standard demo board (schematic is shown in Figure 10) when the LOM port is terminated with 50Ω to GND. The values of L1, L2, C9 and C10 are chosen such that the bandwidth for the LOP port of the standard demo board is maximized while meeting the LO input return loss S_{11, ON} < -10dB.

Table 2. LOP Port Input Impedance vs Frequency for EN = High and P_{LO} = 0dBm (LOM AC Coupled With 50Ω to Ground).

FREQUENCY (MHz)	LO INPUT IMPEDANCE	REFLECTION COEFFICIENT	
		MAG	ANGLE
0.1	333 - j10.0	0.739	-0.5
1	318 - j59.9	0.737	-3.3
2	285 - j94.7	0.728	-6.1
4	227 - j120	0.708	-10.6
8	154 - j124	0.678	-18.7
16	89.9 - j95.4	0.611	-33.0
30	60.4 - j60.6	0.420	-41.3
60	54.8 - j35.8	0.489	-51.5
100	43.6 - j24.4	0.261	-89.9
200	37.9 - j17.3	0.235	-113
400	31.8 - j12.4	0.266	-137
800	23.6 - j8.2	0.374	-156
1000	19.8 - j5.5	0.437	-165
1250	16.0 - j1.8	0.515	-175
1500	13.6 + j2.4	0.574	174
1800	12.1 + j7.3	0.618	162

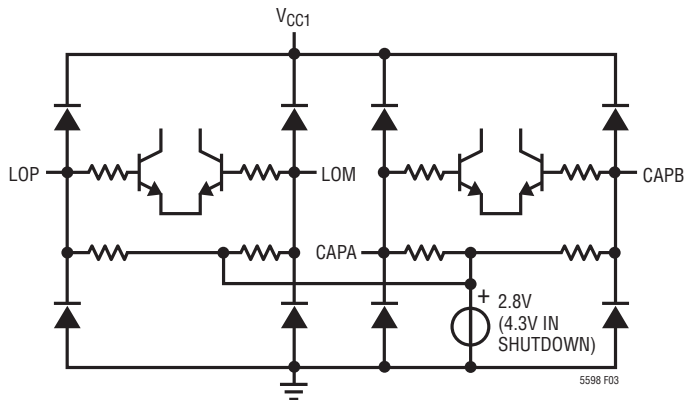

Figure 3. Simplified Circuit Schematic for the LOP, LOM, CAPA and CAPB Inputs.

APPLICATIONS INFORMATION

Table 3. LOP Port Input Impedance vs Frequency for EN = Low and P_{LO} = 0dBm (LOM AC Coupled with 50Ω to Ground).

FREQUENCY (MHz)	LO INPUT IMPEDANCE	REFLECTION COEFFICIENT	
		MAG	ANGLE
0.1	1376 – j84.4	0.930	–0.3
1	541 – j1593	0.980	–3.2
2	177 – j877	0.977	–6.2
4	75.3 – j452	0.965	–12.2
8	49.2 – j228	0.918	–23.6
16	43.3 – j117	0.784	–41.8
30	40.7 – j64.1	0.585	–62.7
60	39.1 – j34.6	0.382	–86
100	37.6 – j23.8	0.296	–102
200	33.4 – j16.4	0.275	–124
400	27.5 – j11.1	0.320	–145
800	20.1 – j4.9	0.430	–167
1000	17.5 – j1.6	0.479	–176
1250	15.3 + j2.1	0.532	175
1500	13.8 + j5.6	0.571	167
1800	12.8 + j9.7	0.605	157

Table 4. LOP Port Input Impedance vs Frequency for EN = High and P_{LO} = 10dBm (LOM AC Coupled with 50Ω to Ground).

FREQUENCY (MHz)	LO INPUT IMPEDANCE	REFLECTION COEFFICIENT	
		MAG	ANGLE
0.1	360-j14.8	0.756	–0.7
1	349-j70.5	0.758	–3.2
2	311-j113	0.752	–6.0
4	240-j148	0.739	–10.9
8	148-j146	0.715	–19.7
16	81.3-j102	0.641	–35.2
30	55.4-j61.6	0.506	–54.7
60	45.7-j34.4	0.341	–77.4
100	43.0-j24.1	0.261	–91.6
200	38.0-j17.1	0.234	–114
400	32.0-j12.5	0.265	–137
800	23.6-j8.3	0.374	–156
1000	19.8-j5.6	0.438	–165
1250	15.8-j1.7	0.520	–176
1500	13.5+j2.4	0.575	174
1800	12.0+j7.3	0.619	162

Table 5. LOP Port Input Impedance vs Frequency for EN = Low and P_{LO} = 10dBm (LOM AC Coupled with 50Ω to Ground).

FREQUENCY (MHz)	LO INPUT IMPEDANCE	REFLECTION COEFFICIENT	
		MAG	ANGLE
0.1	454 – j30.5	0.802	–0.9
1	423 – j102	0.780	–3.2
2	365 – j165	0.796	–5.9
4	249 – j219	0.798	–11.4
8	117 – j179	0.781	–22.4
16	60.7 – j106	0.697	–40.3
30	43.1 – j62.0	0.559	–62.4
60	38.6 – j34.6	0.386	–86.7
100	37.6 – j23.9	0.297	–102
200	33.5 – j16.5	0.274	–124
400	27.6 – j11.3	0.319	–145
800	20.2 – j5.1	0.429	–166
1000	17.7 – j1.7	0.478	–175
1250	15.2 + j2.0	0.533	175
1500	13.9 + j5.4	0.570	167
1800	12.9 + j9.5	0.604	158

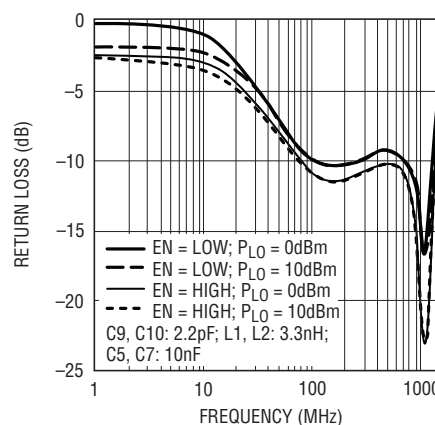

Figure 4. LOP Port Return Loss vs Frequency for Standard Board (See Figure 10)

APPLICATIONS INFORMATION

The LOP port return loss for the low end of the operating frequency range can be optimized using extra 120Ω terminations at the LO inputs (replace C9 and C10 with 120Ω resistors, see Figure 10), and is shown in Figure 5.

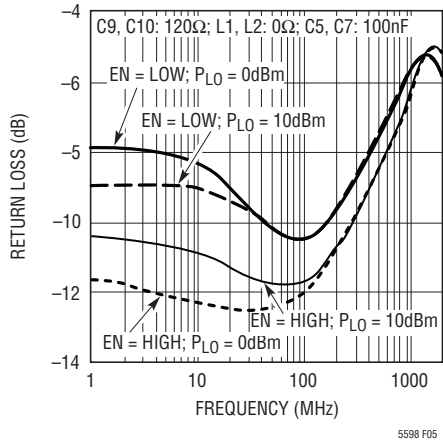

Figure 5. LO Port Return Loss vs Frequency Optimized for Low Frequency (See Figure 10)

The LOP port return loss for the high end of the operating frequency range can be optimized using slightly different values for C9, C10 and L1, L2 (see Figure 6).

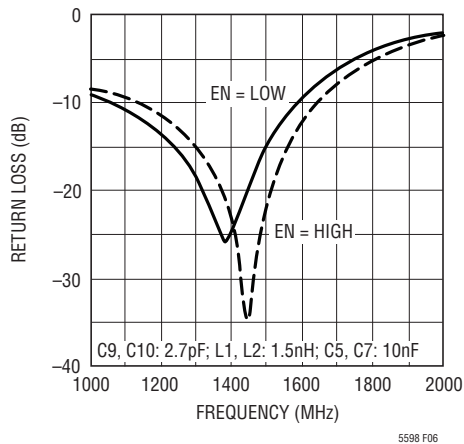

Figure 6. LO Port Return Loss vs Frequency Optimized for High Frequency (See Figure 10)

The third-harmonic rejection on the applied LO signal is recommended to be equal or better than the desired image rejection performance since third-harmonic LO content can degrade the image rejection severely. Image rejection is not sensitive to second-harmonic LO content.

The large-signal noise figure can be improved with a higher LO input power. However, if the LO input power is too large and causes internal clipping in the phase shifter section, the image rejection can be degraded rapidly. This clipping point depends on the supply voltage, LO frequency, temperature and single-ended vs differential LO drive. At $f_{LO} = 140\text{MHz}$, $V_{CC} = 5\text{V}$, $T = 25^\circ\text{C}$ and single-ended LO drive, this clipping point is at about 16.6dBm. For 4.5V it lowers to 14.6dBm. For differential drive with $V_{CC} = 5\text{V}$ it is about 20dBm.

The differential LO port input impedance for EN = High and $P_{LO} = 10\text{dBm}$ is given in Table 6.

Table 6. LOP - LOM Port Differential Input Impedance vs Frequency for EN = High and $P_{LO} = 10\text{dBm}$

FREQUENCY (MHz)	LO DIFFERENTIAL INPUT IMPEDANCE
0.1	642 - j25.7
1.0	626 - j112
2.0	572 - j204
4.0	429 - j305
8.0	222 - j287
16	102 - j181
30	64.2 - j104
60	50.9 - j58.9
100	46.2 - j40.2
200	37.4 - j28.6
400	28.3 - j19.4
800	20.0 - j10.6
1000	17.5 - j7.9
1250	16.6 - j2.7
1500	17.3 + j3.3
1800	20.6 + j10.2

RF Section

After upconversion, the RF outputs of the I and Q mixers are combined. An on-chip buffer performs internal differential to single-ended conversion, while transforming the output impedance to 50Ω. Table 7 shows the RF port output impedance vs frequency for EN = High.

APPLICATIONS INFORMATION

Table 7. RF Output Impedance vs Frequency for EN = High

FREQUENCY (MHz)	RF OUTPUT IMPEDANCE	REFLECTION COEFFICIENT	
		MAG	ANGLE
0.1	59.0 – j0.6	0.083	–3.6
1	58.5 – j2.1	0.081	–12.7
2	57.3 – j3.5	0.076	–23.6
4	54.6 – j4.5	0.061	–41.6
8	51.9 – j3.6	0.040	–60.8
16	50.5 – j2.1	0.022	–74.8
30	50.2 – j1.1	0.011	–80
60	50 – j0.5	0.005	–86.5
100	50 – j0.2	0.002	–84.9
200	49.7 + j0	0.003	177.4
400	48.9 + j0.3	0.011	162
800	46.1 + j0.4	0.041	173.3
1000	44.5 + j0.2	0.058	178
1250	42.8 + j0	0.077	–179.7
1500	41.2 – j0.1	0.097	–179.4
1800	39.9 + j0.4	0.113	177.4

The RF port output impedance for EN = Low is given in Table 8. It is roughly equivalent to a 1.3pF capacitor to ground.

Table 8. RF Output Impedance vs Frequency for EN = Low

FREQUENCY (MHz)	LO INPUT IMPEDANCE	REFLECTION COEFFICIENT	
		MAG	ANGLE
100	82.3 – j1223	0.995	–4.6
200	51.1 – j618	0.987	–9.2
400	35.3 – j310	0.965	–18.1
800	24.4 – j148	0.906	–36.6
1000	20.4 – j114	0.878	–46.4
1250	17 – j87	0.847	–58.4
1500	14.7 – j68	0.818	–70.7
1800	13.1 – j54	0.785	–84.3

In Figure 7 the simplified circuit schematic of the RF output buffer is drawn. A plot of the RF port return loss vs frequency is drawn in Figure 8 for EN = High and Low.

Enable Interface

Figure 9 shows a simplified schematic of the EN pin interface. The voltage necessary to turn on the LTC5598 is 2V. To disable (shut down) the chip, the enable voltage

must be below 1V. If the EN pin is not connected, the chip is enabled. This EN = High condition is assured by the 125k on-chip pull-up resistor. It is important that the voltage at the EN pin does not exceed V_{CC} by more than 0.3V. Should

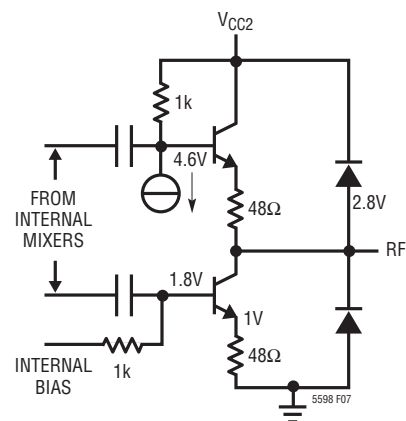

Figure 7. Simplified Circuit Schematic of the RF Output

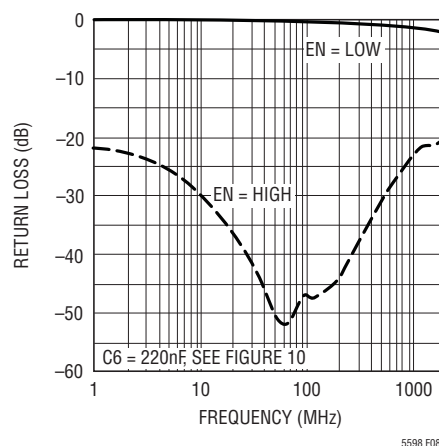

Figure 8. RF Port Return Loss vs Frequency

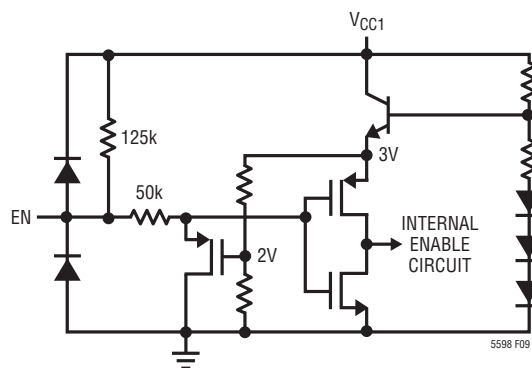

Figure 9. EN Pin Interface

APPLICATIONS INFORMATION

this occur, the supply current could be sourced through the EN pin ESD protection diodes, which are not designed to carry the full supply current, and damage may result.

Evaluation Board

Figure 10 shows the evaluation board schematic. A good ground connection is required for the exposed pad. If this is not done properly, the RF performance will degrade. Additionally, the exposed pad provides heat sinking for the part and minimizes the possibility of the chip overheating. Resistors R1 and R2 reduce the charging current in capacitors C1 and C4 (see Figure 10) and will reduce supply ringing during a fast power supply ramp-up in case an inductive cable is connected to the V_{CC} and GND turrets. For EN = High, the voltage drop over R1 and R2 is about 0.15V. If a power supply is used that ramps up slower than 10V/μs and limits the overshoot on the supply below 5.6V, R1 and R2 can be omitted.

The LTC5598 can be used for base-station applications with various modulation formats. Figure 13 shows a typical application.

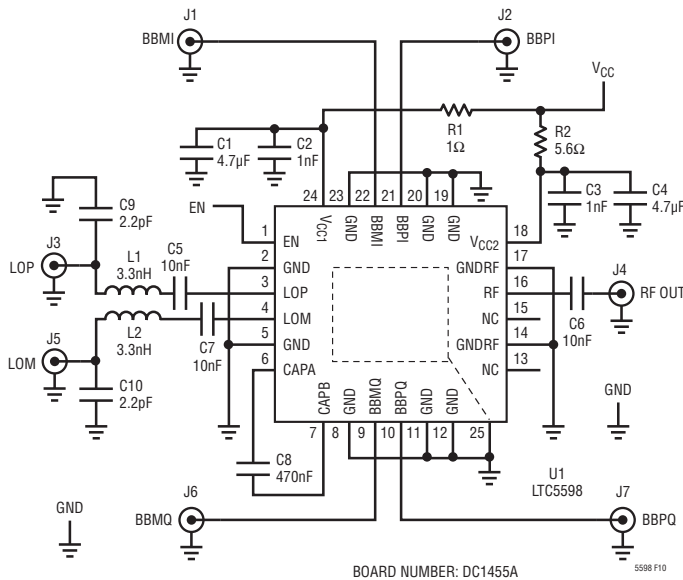

Figure 10. Evaluation Circuit Schematic

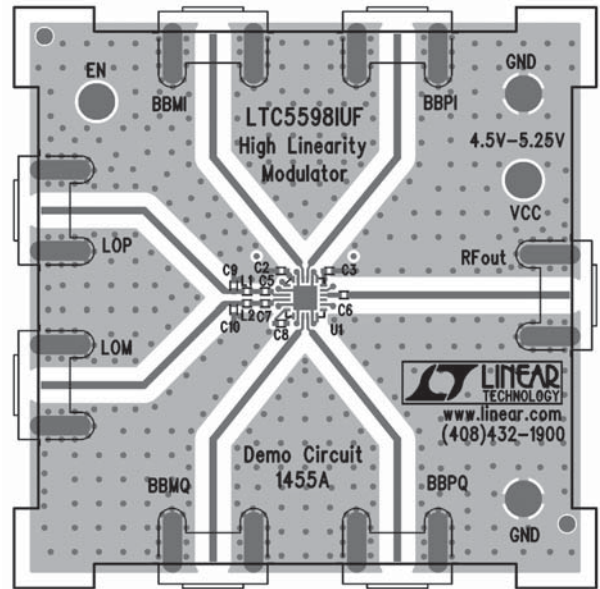

Figure 11. Component Side of Evaluation Board

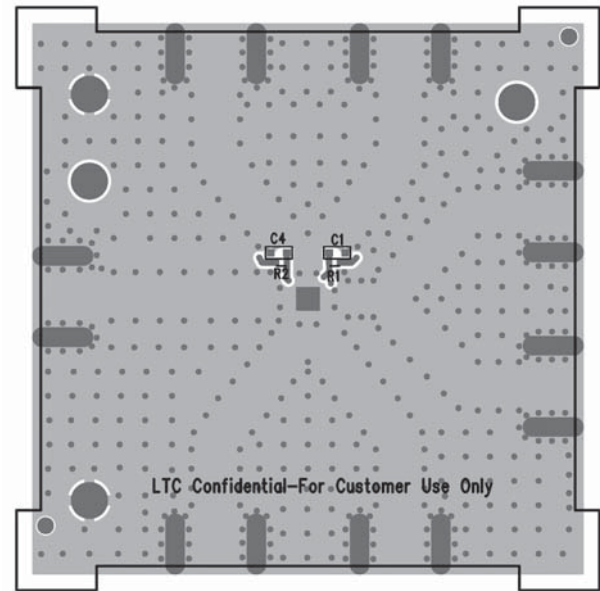

Figure 12. Bottom Side of Evaluation Board

APPLICATIONS INFORMATION

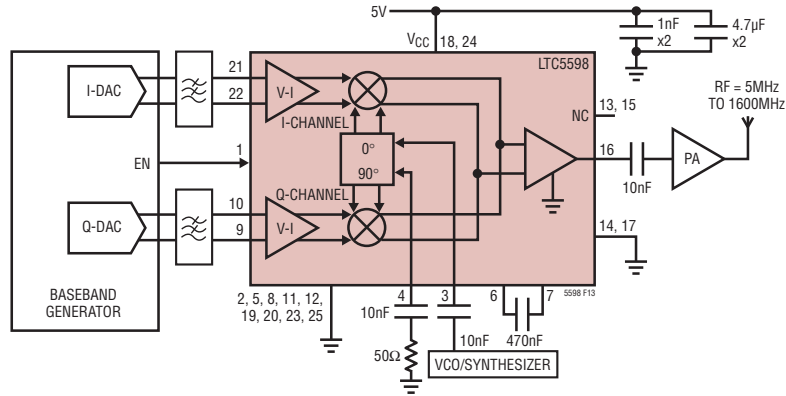
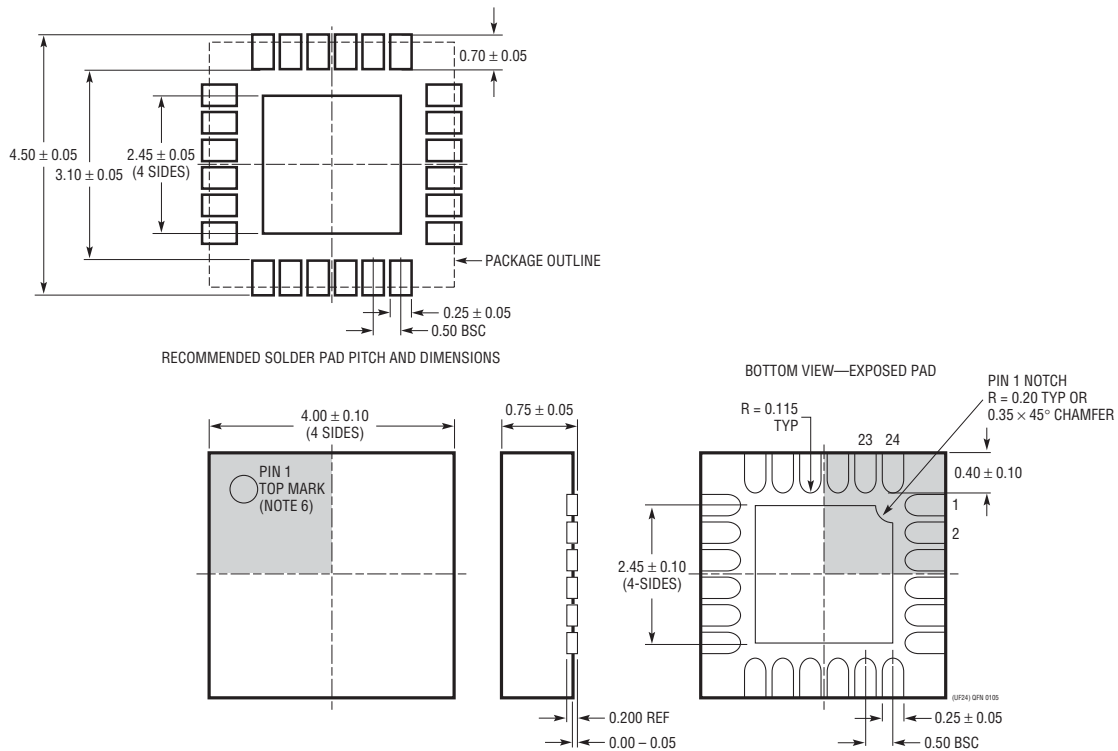

Figure 13: 5MHz to 1600MHz Direct Conversion Transmitter Application

PACKAGE DESCRIPTION

UF Package
24-Lead (4mm × 4mm) Plastic QFN
 (Reference LTC DWG # 05-08-1697)



- NOTE:
1. DRAWING PROPOSED TO BE MADE A JEDEC PACKAGE OUTLINE MO-220 VARIATION (WGGD-X)—TO BE APPROVED
 2. DRAWING NOT TO SCALE
 3. ALL DIMENSIONS ARE IN MILLIMETERS
 4. DIMENSIONS OF EXPOSED PAD ON BOTTOM OF PACKAGE DO NOT INCLUDE MOLD FLASH. MOLD FLASH, IF PRESENT, SHALL NOT EXCEED 0.15mm ON ANY SIDE, IF PRESENT
 5. EXPOSED PAD SHALL BE SOLDER PLATED
 6. SHADED AREA IS ONLY A REFERENCE FOR PIN 1 LOCATION ON THE TOP AND BOTTOM OF PACKAGE

RELATED PARTS

PART NUMBER	DESCRIPTION	COMMENTS
Infrastructure		
LT5514	Ultralow Distortion, IF Amplifier/ADC Driver with Digitally Controlled Gain	850MHz Bandwidth, 47dBm OIP3 at 100MHz, 10.5dB to 33dB Gain Control Range
LT5517	40MHz to 900MHz Quadrature Demodulator	21dBm IIP3, Integrated LO Quadrature Generator
LT5518	1.5GHz to 2.4GHz High Linearity Direct Quadrature Modulator	22.8dBm OIP3 at 2GHz, -158.2dBm/Hz Noise Floor, 50Ω Single-Ended RF and LO Ports, 4-Channel W-CDMA ACPR = -64dBc at 2.14GHz
LT5519	0.7GHz to 1.4GHz High Linearity Upconverting Mixer	17.1dBm IIP3 at 1GHz, Integrated RF Output Transformer with 50Ω Matching, Single-Ended LO and RF Ports Operation
LT5520	1.3GHz to 2.3GHz High Linearity Upconverting Mixer	15.9dBm IIP3 at 1.9GHz, Integrated RF Output Transformer with 50Ω Matching, Single-Ended LO and RF Ports Operation
LT5521	10MHz to 3700MHz High Linearity Upconverting Mixer	24.2dBm IIP3 at 1.95GHz, NF = 12.5dB, 3.15V to 5.25V Supply, Single-Ended LO Port Operation
LT5522	600MHz to 2.7GHz High Signal Level Downconverting Mixer	4.5V to 5.25V Supply, 25dBm IIP3 at 900MHz, NF = 12.5dB, 50Ω Single-Ended RF and LO Ports
LT5527	400MHz to 3.7GHz High Signal Level Downconverting Mixer	IIP3 = 23.5dBm and NF = 12.5dBm at 1900MHz, 4.5V to 5.25V Supply, I _{CC} = 78mA, Conversion Gain = 2dB.
LT5528	1.5GHz to 2.4GHz High Linearity Direct Quadrature Modulator	21.8dBm OIP3 at 2GHz, -159.3dBm/Hz Noise Floor, 50Ω, 0.5V _{DC} Baseband Interface, 4-Channel W-CDMA ACPR = -66dBc at 2.14GHz
LT5554	Broadband Ultra Low Distortion 7-Bit Digitally Controlled VGA	48dBm OIP3 at 200MHz, 1.4nV/√Hz Input-Referred Noise, 2dB to 18dB Gain Range, 0.125dB Gain Step Size
LT5557	400MHz to 3.8GHz High Signal Level Downconverting Mixer	IIP3 = 23.7dBm at 2600MHz, 23.5dBm at 3600MHz, I _{CC} = 82mA at 3.3V
LT5560	Ultra-Low Power Active Mixer	10mA Supply Current, 10dBm IIP3, 10dB NF, Usable as Up- or Down-Converter.
LT5568	700MHz to 1050MHz High Linearity Direct Quadrature Modulator	22.9dBm OIP3 at 850MHz, -160.3dBm/Hz Noise Floor, 50Ω, 0.5V _{DC} Baseband Interface, 3-Ch CDMA2000 ACPR = -71.4dBc at 850MHz
LT5571	620MHz - 1100MHz High Linearity Quadrature Modulator	21.7dBm OIP3 at 900MHz, -159dBm/Hz Noise Floor, High-Ohmic 0.5V _{DC} Baseband Interface
LT5572	1.5GHz to 2.5GHz High Linearity Direct Quadrature Modulator	21.6dBm OIP3 at 2GHz, -158.6dBm/Hz Noise Floor, High-Ohmic 0.5V _{DC} Baseband Interface, 4-Ch W-CDMA ACPR = -67.7dBc at 2.14GHz
LT5575	800MHz to 2.7GHz High Linearity Direct Conversion I/Q Demodulator	50Ω, Single-Ended RF and LO Ports, 28dBm IIP3 at 900MHz, 13.2dBm P1dB, 0.04dB I/Q Gain Mismatch, 0.4° I/Q Phase Mismatch
LT5579	1.5GHz to 3.8GHz High Linearity Upconverting Mixer	27.3dBm OIP3 at 2.14GHz, 9.9dB Noise Floor, 2.6dB Conversion Gain, -35dBm LO Leakage
RF Power Detectors		
LTC [®] 5505	RF Power Detectors with >40dB Dynamic Range	300MHz to 3GHz, Temperature Compensated, 2.7V to 6V Supply
LTC5507	100kHz to 1000MHz RF Power Detector	100kHz to 1GHz, Temperature Compensated, 2.7V to 6V Supply
LTC5508	300MHz to 7GHz RF Power Detector	44dB Dynamic Range, Temperature Compensated, SC70 Package
LTC5509	300MHz to 3GHz RF Power Detector	36dB Dynamic Range, Low Power Consumption, SC70 Package
LTC5530	300MHz to 7GHz Precision RF Power Detector	Precision V _{OUT} Offset Control, Shutdown, Adjustable Gain
LTC5531	300MHz to 7GHz Precision RF Power Detector	Precision V _{OUT} Offset Control, Shutdown, Adjustable Offset
LTC5532	300MHz to 7GHz Precision RF Power Detector	Precision V _{OUT} Offset Control, Adjustable Gain and Offset
LT5534	50MHz to 3GHz Log RF Power Detector with 60dB Dynamic Range	±1dB Output Variation over Temperature, 38ns Response Time, Log Linear Response
LTC5536	Precision 600MHz to 7GHz RF Power Detector with Fast Comparator Output	25ns Response Time, Comparator Reference Input, Latch Enable Input, -26dBm to +12dBm Input Range
LT5537	Wide Dynamic Range Log RF/IF Detector	Low Frequency to 1GHz, 83dB Log Linear Dynamic Range
LT5538	3.8GHz Wide Dynamic Range Log Detector	75dB Dynamic Range, ±1dB Output Variation Over Temperature
LT5570	2.7GHz RMS Power Detector	Fast Responding, up to 60dB Dynamic Range, ±0.3dB Accuracy Over Temperature
LT5581	40dB Dynamic Range RMS Detector	10MHz to 6GHz, ±1dB Accuracy Over Temperature, 1.4mA at 3.3V Supply

Looking for pricing, stock, or lifecycle information?

Click below to explore more details on WIN SOURCE:

 [View LTC5598IUF](#) on WIN SOURCE

 [Linear Technology](#) Information

Optimize Your Supply Chain with WIN SOURCE Solutions

-  Global Sourcing Solution
-  Obsolete Management
-  Cost Control Management
-  Shortage Management
-  Alternative Solution
-  Excess Inventory Management