



**THE DATASHEET OF
LTC4440AIMS8E-5#PBF**



FEATURES

- Wide Operating V_{IN} Range: Up to 80V
- Rugged Architecture Tolerant of 100V V_{IN} Transients
- Powerful 1.85Ω Driver Pull-Down (with 6V Supply)
- Powerful 1.1A Peak Current Driver Pull-Up (with 6V Supply)
- 7ns Fall Time Driving 1000pF Load
- 10ns Rise Time Driving 1000pF Load
- Drives Standard Threshold MOSFETs
- TTL/CMOS Compatible Inputs with Hysteresis
- Input Thresholds are Independent of Supply
- Undervoltage Lockout
- Thermally Enhanced 8-Lead MSOP Package

APPLICATIONS

- Automotive Power Systems
- Telecommunications Power Systems
- Distributed Power Architectures
- Server Power Supplies
- High Density Power Modules
- General Purpose Low or High Side Driver

LT, LTC, LTM, Linear Technology and the Linear logo are registered trademarks and Direct Flux Limit is a trademark of Linear Technology Corporation. All other trademarks are the property of their respective owners. Protected by U.S. Patents, including 6677210.

DESCRIPTION

The **LTC[®]4440A-5** is a high frequency high side N-channel MOSFET gate driver that is designed to operate in applications with V_{IN} voltages up to 80V. The LTC4440A-5 can also withstand and continue to function during 100V V_{IN} transients. The powerful driver capability reduces switching losses in MOSFETs with high gate capacitances. The LTC4440A-5's pull-up has a peak output current of 1.1A and its pull-down has an output impedance of 1.85Ω .

The LTC4440A-5 features supply independent TTL/CMOS compatible input thresholds with 350mV of hysteresis. The input logic signal is internally level-shifted to the bootstrapped supply, which may function at up to 95V above ground.

The LTC4440A-5 is optimized for driving (5V) logic level FETs and contains an undervoltage lockout circuit that disables the external MOSFET when activated.

The LTC4440A-5 is available in the thermally enhanced 8-lead MSOP package.

PARAMETER	LTC4440A-5	LTC4440-5	LTC4440
Max Operating TS	80V	60V	80V
Absolute Max TS	100V	80V	100V
MOSFET Gate Drive	4V to 15V	4V to 15V	8V to 15V
V_{CC} UV ⁺	3.2V	3.2V	6.3V
V_{CC} UV ⁻	3.04V	3.04V	6.0V

TYPICAL APPLICATION

Synchronous Phase-Modulated Full-Bridge Converter

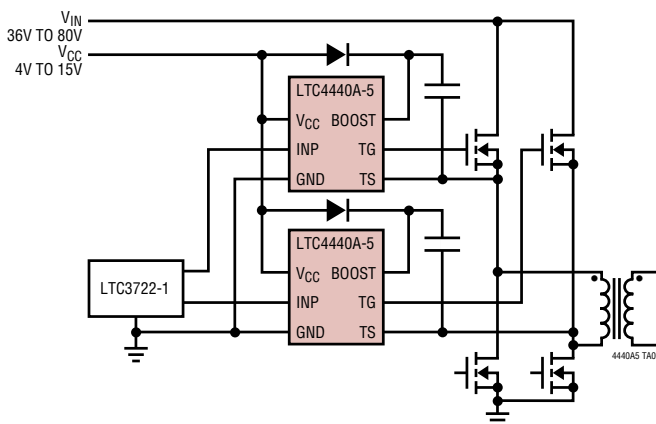

LTC4440A-5 Driving a 1000pF Capacitive Load

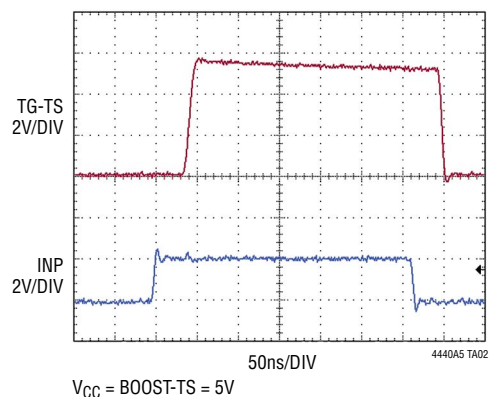

4440a5f

LTC4440A-5

ABSOLUTE MAXIMUM RATINGS

(Note 1)

Supply Voltage

V_{CC}	-0.3V to 15V
BOOST – TS	-0.3V to 15V
INP Voltage	-0.3V to 15V
BOOST Voltage (Continuous)	-0.3V to 95V
BOOST Voltage (100ms)	-0.3V to 115V
TS Voltage (Continuous)	-5V to 80V
TS Voltage (100ms)	-5V to 100V
Operating Junction Temperature Range (Notes 2, 3)	
LTC4440AI-5	-40°C to 125°C
LTC4440AH-5	-40°C to 150°C
LTC4440AMP-5	-55°C to 150°C
Storage Temperature Range	-65°C to 150°C
Lead Temperature (Soldering, 10 sec)	300°C

PIN CONFIGURATION

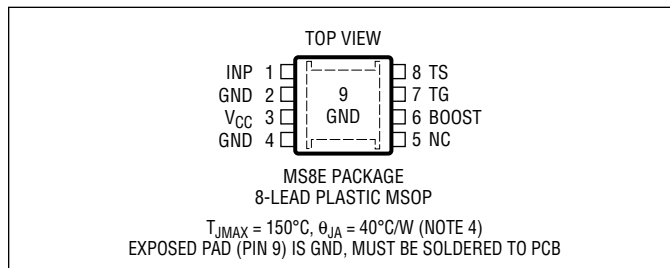

ORDER INFORMATION

LEAD FREE FINISH	TAPE AND REEL	PART MARKING*	PACKAGE DESCRIPTION	TEMPERATURE RANGE
LTC4440AIMS8E-5#PBF	LTC4440AIMS8E-5#TRPBF	LTGKP	8-Lead Plastic MSOP	-40°C to 125°C
LTC4440AHMS8E-5#PBF	LTC4440AHMS8E-5#TRPBF	LTGKP	8-Lead Plastic MSOP	-40°C to 150°C
LTC4440AMPMS8E-5#PBF	LTC4440AMPMS8E-5#TRPBF	LTGKP	8-Lead Plastic MSOP	-55°C to 150°C

Consult LTC Marketing for parts specified with wider operating temperature ranges. *The temperature grade is identified by a label on the shipping container. Consult LTC Marketing for information on nonstandard lead based finish parts.

For more information on lead free part marking, go to: <http://www.linear.com/leadfree/>

For more information on tape and reel specifications, go to: <http://www.linear.com/tapeandreel/>

ELECTRICAL CHARACTERISTICS

The ● denotes specifications which apply over the specified operating junction temperature range, otherwise specifications are at $T_A = 25^\circ\text{C}$. $V_{CC} = V_{BOOST} = 6\text{V}$, $V_{TS} = \text{GND} = 0\text{V}$, unless otherwise noted. (Note 2)

SYMBOL	PARAMETER	CONDITIONS	MIN	TYP	MAX	UNITS
Main Supply (V_{CC})						
I_{VCC}	DC Supply Current Normal Operation UVLO	INP = 0V $V_{CC} < \text{UVLO Threshold (Falling)} - 0.1\text{V}$		200 18	325 40	μA μA
UVLO	Undervoltage Lockout Threshold	V_{CC} Rising V_{CC} Falling Hysteresis	● 2.75 ● 2.60	3.20 3.04	3.65 3.50	V V mV
Bootstrapped Supply (BOOST – TS)						
I_{BOOST}	DC Supply Current Normal Operation	INP = 0V INP = 6V		0 310	450	μA μA

4440a5f

ELECTRICAL CHARACTERISTICS

The ● denotes specifications which apply over the specified operating junction temperature range, otherwise specifications are at $T_A = 25^\circ\text{C}$. $V_{CC} = V_{BOOST} = 6\text{V}$, $V_{TS} = \text{GND} = 0\text{V}$, unless otherwise noted. (Note 2)

SYMBOL	PARAMETER	CONDITIONS	MIN	TYP	MAX	UNITS
Input Signal (INP)						
V_{IH}	High Input Threshold	INP Ramping High	● 1.2	1.55	2	V
V_{IL}	Low Input Threshold	INP Ramping Low	● 0.8	1.25	1.6	V
$V_{IH} - V_{IL}$	Input Voltage Hysteresis			0.350		V
I_{INP}	Input Pin Bias Current			± 0.01	± 2	μA
Output Gate Driver (TG)						
V_{OH}	High Output Voltage	$I_{TG} = -10\text{mA}$, $V_{OH} = V_{BOOST} - V_{TG}$		0.7		V
V_{OL}	Low Output Voltage	$I_{TG} = 100\text{mA}$	●	185	400	mV
I_{PU}	Peak Pull-Up Current		● 0.7	1.1		A
R_{DS}	Output Pull-Down Resistance		●	1.85	4	Ω
Switching Timing						
t_r	Output Rise Time	10% – 90%, $C_L = 1\text{nF}$		10		ns
		10% – 90%, $C_L = 10\text{nF}$		100		ns
t_f	Output Fall Time	10% – 90%, $C_L = 1\text{nF}$		7		ns
		10% – 90%, $C_L = 10\text{nF}$		70		ns
t_{PLH}	Output Low-High Propagation Delay		●	35	80	ns
t_{PHL}	Output High-Low Propagation Delay		●	33	80	ns

Note 1: Stresses beyond those listed under Absolute Maximum Ratings may cause permanent damage to the device. Exposure to any Absolute Maximum Rating condition for extended periods may affect device reliability and lifetime.

Note 2: The LTC4440A-5 is tested under pulsed load conditions such that $T_J \approx T_A$. The LTC4440AI-5 is guaranteed over the -40°C to 125°C operating junction temperature range, The LTC4440AH-5 is guaranteed over the -40°C to 150°C operating junction temperature range and the LTC4440AMP-5 is tested and guaranteed over the -55°C to 150°C operating junction temperature range.

High junction temperatures degrade operating lifetimes; operating lifetime is derated to junction temperatures greater than 125°C . Note that the maximum ambient temperature consistent with these specifications is determined by specific operating conditions in conjunction with board layout, the rated package thermal impedance and other environment factors.

Note 3: T_J is calculated from the ambient temperature T_A and power dissipation PD according to the following formula:

$$T_J = T_A + (PD \cdot \theta_{JA}^\circ\text{C/W})$$

Continuous operation above the specified absolute operating junction temperature may impair device reliability or permanently damage the device.

Note 4: Failure to solder the exposed pad of the MS8E package to the PC board will result in a thermal resistance much higher than 40°C/W .

TYPICAL PERFORMANCE CHARACTERISTICS

V_{CC} Supply Quiescent Current vs Voltage

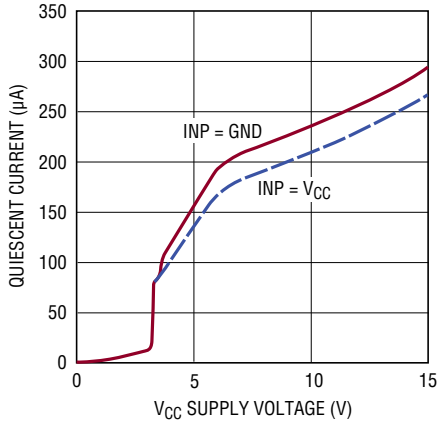

4440A5 G01

BOOST-TS Supply Quiescent Current vs Voltage

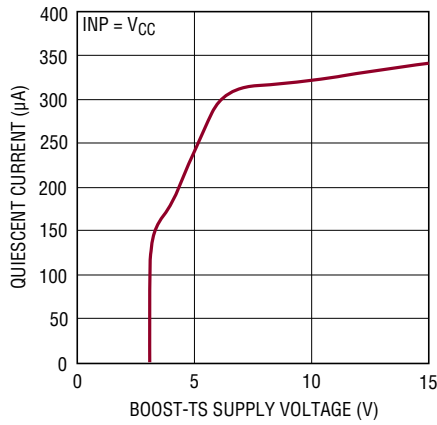

4440A5 G02

Output Low Voltage (V_{OL}) vs Supply Voltage

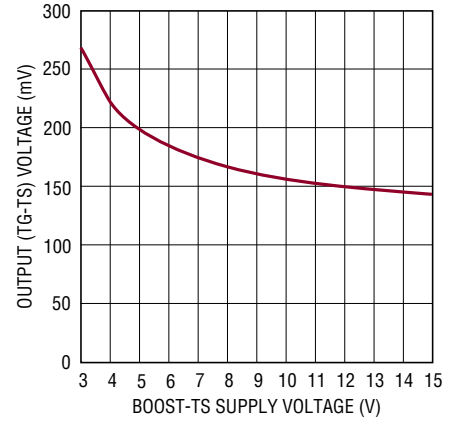

4440A5 G03

Output High Voltage (V_{OH}) vs Supply Voltage

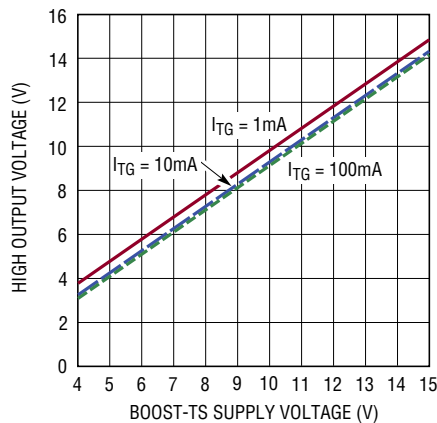

4440A5 G04

Input (INP) Thresholds vs Supply Voltage

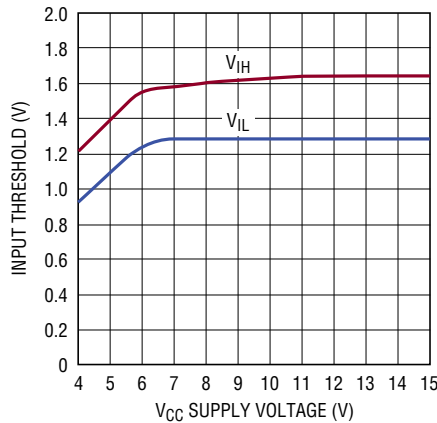

4440A5 G05

2MHz Operation

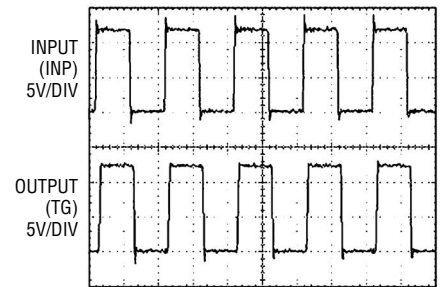

V_{CC} = BOOST-TS = 12V

4440A5 G06

V_{CC} Supply Current vs Temperature

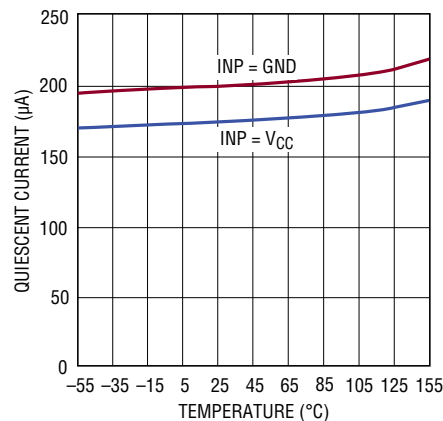

4440A5 G07

V_{CC} Undervoltage Lockout Thresholds vs Temperature

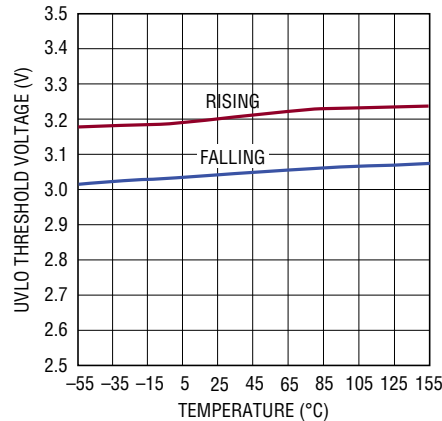

4440A5 G08

BOOST-TS Quiescent Current vs Temperature

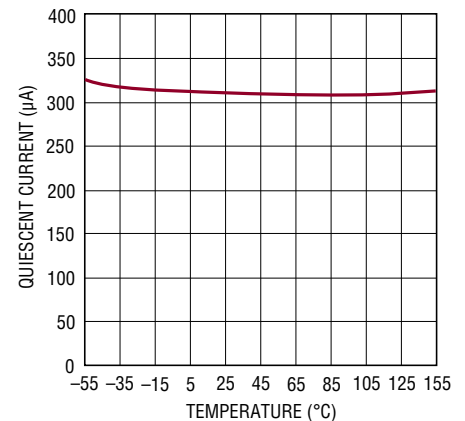

4440A5 G09

TYPICAL PERFORMANCE CHARACTERISTICS

Input (INP) Threshold vs Temperature

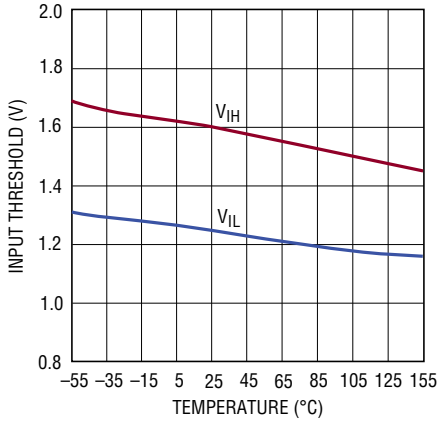

4440A5 G10

Input Threshold Hysteresis vs Temperature

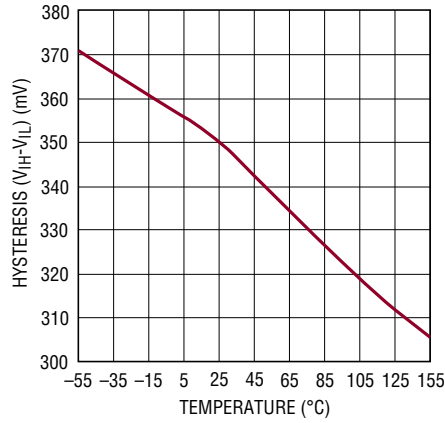

4440A5 G11

Peak Driver (TG) Pull-Up Current vs Temperature

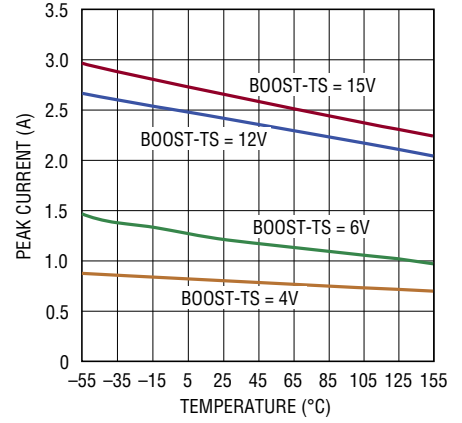

4440A5 G12

Output Driver Pull-Down Resistance vs Temperature

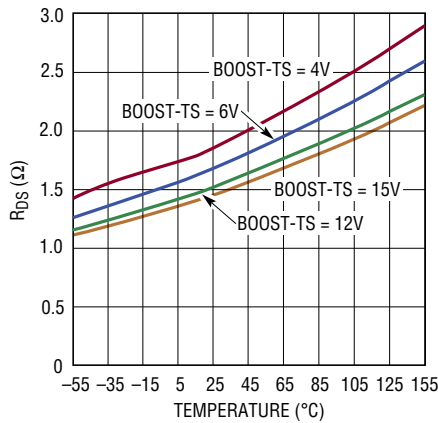

4440A5 G13

Propagation Delay vs Temperature

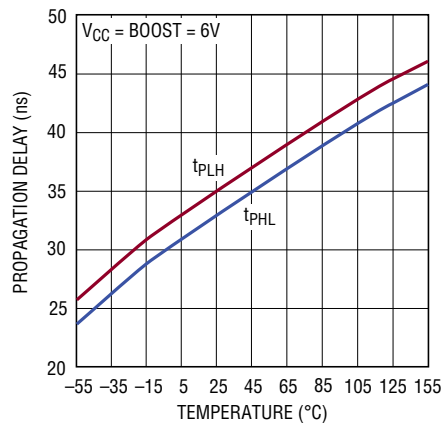

4440A5 G14

Driving a 3300pF Capacitive Load

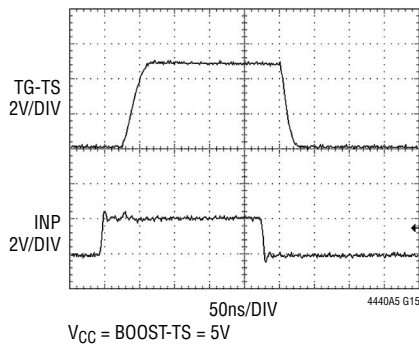

Driving a 3300pF Capacitive Load

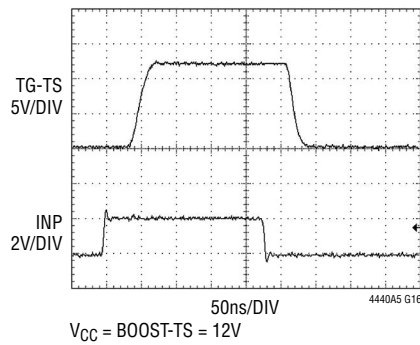

PIN FUNCTIONS

INP (Pin 1): Input Signal. TTL/CMOS compatible input referenced to GND (Pin 2).

GND (Pins 2, 4, Exposed Pad Pin 9): Ground. The exposed pad must be electrically connected to Pins 2 and 4 and soldered to PCB ground for rated thermal performance.

V_{CC} (Pin 3): Chip Supply. This pin powers the internal low side circuitry. A low ESR ceramic bypass capacitor should be tied between this pin and the GND pin (Pin 2).

NC (Pin 5): No Connect. No connection required. For convenience, this pin may be tied to Pin 6 (BOOST) on the application board.

BOOST (Pin 6): High Side Bootstrapped Supply. An external capacitor should be tied between this pin and TS (Pin 8). Normally, a bootstrap diode is connected between V_{CC} (Pin 3) and this pin. Voltage swing at this pin is from V_{CC} - V_D to V_{IN} + V_{CC} - V_D, where V_D is the forward voltage drop of the bootstrap diode.

TG (Pin 7): High Current Gate Driver Output (Top Gate). This pin swings between TS and BOOST.

TS (Pin 8): Top (High Side) source connection or GND if used in ground referenced applications.

BLOCK DIAGRAM

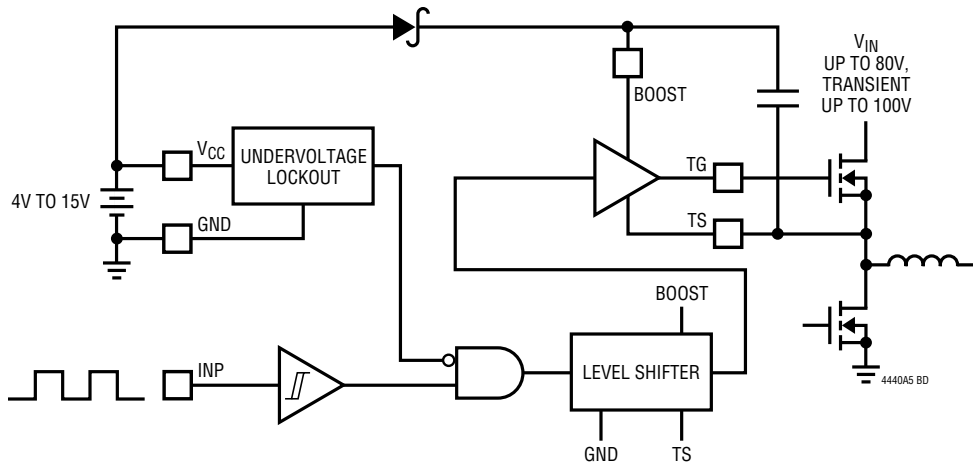

TIMING DIAGRAM

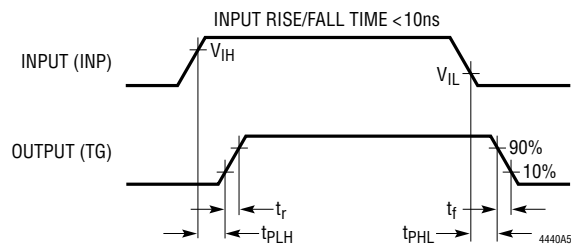

APPLICATIONS INFORMATION

Overview

The LTC4440A-5 receives a ground-referenced, low voltage digital input signal to drive a high side N-channel power MOSFET whose drain can float up to 80V above ground, eliminating the need for a transformer between the low voltage control signal and the high side gate driver. The LTC4440A-5 normally operates in applications with input supply voltages (V_{IN}) up to 80V, but is able to withstand and continue to function during 100V, 100ms transients on the input supply.

The powerful output driver of the LTC4440A-5 reduces the switching losses of the power MOSFET, which increase with transition time. The LTC4440A-5 is capable of driving a 1nF load with 10ns rise and 7ns fall times using a bootstrapped supply voltage $V_{BOOST-TS}$ of 6V.

Input Stage

The LTC4440A-5 employs TTL/CMOS compatible input logic level or thresholds that allow a low voltage digital signal to drive standard threshold power MOSFETs. The LTC4440A-5 contains an internal voltage regulator that biases the input buffer, allowing the input thresholds ($V_{IH} = 1.6V$, $V_{IL} = 1.25V$) to be relatively independent of variations in V_{CC} . The 350mV hysteresis between V_{IH} and V_{IL} eliminates false triggering due to noise during switching transitions. However, care should be taken to keep this pin from any noise pickup, especially in high frequency, high voltage applications. The LTC4440A-5 input buffer has a high input impedance and draws negligible input current, simplifying the drive circuitry required for the input.

Output Stage

A simplified version of the LTC4440A-5's output stage is shown in Figure 1. The pull-down device is an N-channel MOSFET (N1) and the pull-up device is an NPN bipolar junction transistor (Q1). The output swings from the lower rail (TS) to within an NPN V_{BE} (~0.7V) of the positive rail (BOOST). This large voltage swing is important in driving external power MOSFETs, whose $R_{DS(ON)}$ is inversely proportional to its gate overdrive voltage ($V_{GS} - V_{TH}$).

The LTC4440A-5's peak pull-up (Q1) current is 1.1A while the pull-down (N1) resistance is 1.85 Ω , with a BOOST-TS supply of 6V. The low impedance of N1 is required to

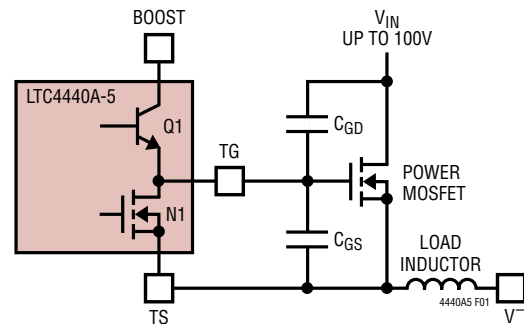

Figure 1. Capacitance Seen by TG During Switching

discharge the power MOSFET's gate capacitance during high-to-low signal transitions. When the power MOSFET's gate is pulled low (gate shorted to source through N1) by the LTC4440A-5, its source (TS) is pulled low by its load (e.g., an inductor or resistor). The slew rate of the source/gate voltage causes current to flow back to the MOSFET's gate through the gate-to-drain capacitance (C_{GD}). If the MOSFET driver does not have sufficient sink current capability (low output impedance), the current through the power MOSFET's C_{GD} can momentarily pull the gate high, turning the MOSFET back on.

A similar scenario exists when the LTC4440A-5 is used to drive a low side MOSFET. When the low side power MOSFET's gate is pulled low by the LTC4440A-5, its drain voltage is pulled high by its load (e.g., inductor or resistor). The slew rate of the drain voltage causes current to flow back to the MOSFET's gate through its gate-to-drain capacitance. If the MOSFET driver does not have sufficient sink current capability (low output impedance), the current through the power MOSFET's C_{GD} can momentarily pull the gate high, turning the MOSFET back on.

Rise/Fall Time

Since the power MOSFET generally accounts for the majority of the power loss in a converter, it is important to quickly turn it on or off, thereby minimizing the transition time in its linear region. The LTC4440A-5 can drive a 1nF load with a 10ns rise time and 7ns fall time.

The LTC4440A-5's rise and fall times are determined by the peak current capabilities of Q1 and N1. The predriver that drives Q1 and N1 uses a nonoverlapping transition scheme to minimize cross-conduction currents. N1 is fully turned off before Q1 is turned on and vice versa.

4440a5f

APPLICATIONS INFORMATION

Power Dissipation

To ensure proper operation and long-term reliability, the LTC4440A-5 must not operate beyond its maximum temperature rating. Package junction temperature can be calculated by:

$$T_J = T_A + PD (\theta_{JA})$$

where:

T_J = Junction Temperature

T_A = Ambient Temperature

PD = Power Dissipation

θ_{JA} = Junction-to-Ambient Thermal Resistance

Power dissipation consists of standby and switching power losses:

$$PD = P_{STDBY} + P_{AC}$$

where:

P_{STDBY} = Standby Power Losses

P_{AC} = AC Switching Losses

The LTC4440A-5 consumes very little current during standby. The DC power loss at $V_{CC} = 6V$ and $V_{BOOST-TS} = 6V$ is only $(200\mu A)(6V) = 1.2mW$ with $INP = 0V$.

AC switching losses are made up of the output capacitive load losses and the transition state losses. The capacitive load losses are primarily due to the large AC currents needed to charge and discharge the load capacitance during switching. Load losses for the output driver driving a pure capacitive load C_{OUT} would be:

$$\text{Load Capacitive Power} = (C_{OUT})(f)(V_{BOOST-TS})^2$$

The power MOSFET's gate capacitance seen by the driver output varies with its V_{GS} voltage level during switching. A power MOSFET's capacitive load power dissipation can be calculated using its gate charge, Q_G . The Q_G value corresponding to the MOSFET's V_{GS} value (V_{CC} in this case) can be readily obtained from the manufacturer's Q_G vs V_{GS} curves:

$$\text{Load Capacitive Power (MOS)} = (V_{BOOST-TS})(Q_G)(f)$$

Transition state power losses are due to both AC currents required to charge and discharge the driver's internal

nodal capacitances and cross-conduction currents in the internal gates.

Undervoltage Lockout (UVLO)

The LTC4440A-5 contains an undervoltage lockout detector that monitors V_{CC} . When V_{CC} falls below 3.04V, the internal buffer is disabled and the output pin TG is pulled down to TS.

Bypassing and Grounding

The LTC4440A-5 requires proper bypassing on the V_{CC} and $V_{BOOST-TS}$ supplies due to its high speed switching (nanoseconds) and large AC currents (Amperes). Careless component placement and PCB trace routing may cause excessive ringing and under/overshoot.

To obtain the optimum performance from the LTC4440A-5:

- A. Mount the bypass capacitors as close as possible between the V_{CC} and GND pins and the BOOST and TS pins. The leads should be shortened as much as possible to reduce lead inductance.
- B. Use a low inductance, low impedance ground plane to reduce any ground drop and stray capacitance. Remember that the LTC4440A-5 switches >2A peak currents and any significant ground drop will degrade signal integrity.
- C. Plan the power/ground routing carefully. Know where the large load switching current is coming from and going to. Maintain separate ground return paths for the input pin and the output power stage.
- D. Keep the copper trace between the driver output pin and the load short and wide.
- E. When using the MS8E package, be sure to solder the exposed pad on the back side of the LTC4440A-5 package to the board. Correctly soldered to a 2500mm² double-sided 1oz copper board, the LTC4440A-5 has a thermal resistance of approximately 40°C/W. Failure to make good thermal contact between the exposed back side and the copper board will result in thermal resistances far greater than 40°C/W.

TYPICAL APPLICATIONS

LTC3722/LTC4440A-5 420W 36V-60V_{IN} to 12V/35A Isolated Full-Bridge Supply

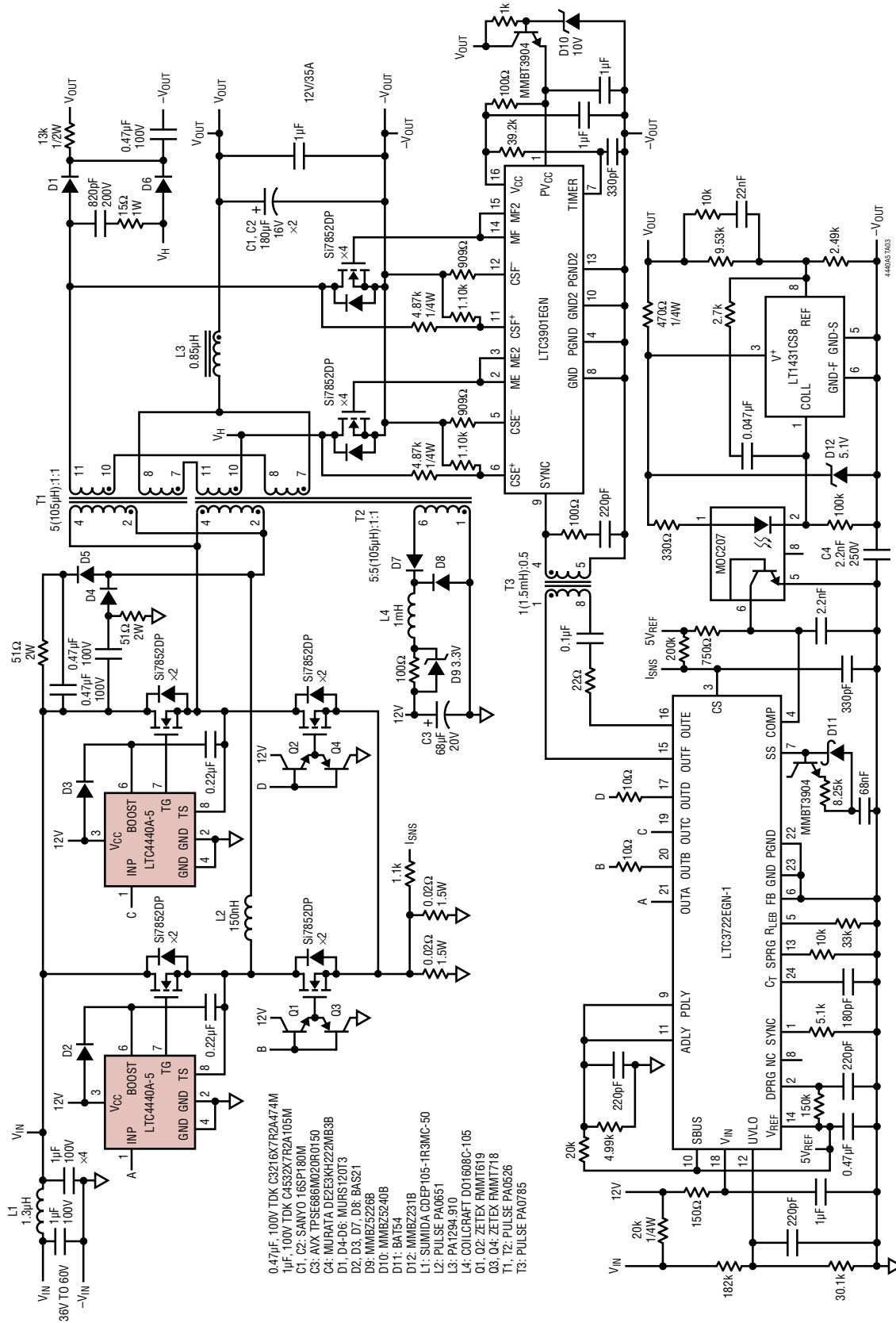

TYPICAL APPLICATIONS

LTC3723-1 240W $42\text{-}56\text{V}_{\text{IN}}$ to $12\text{V}/20\text{A}$ Isolated 1/4Brick ($2.3" \times 1.45"$)

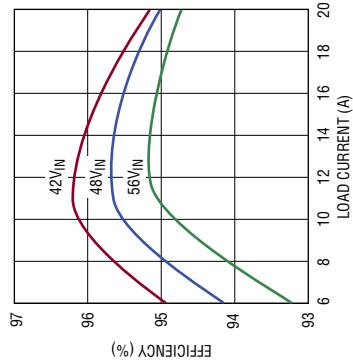
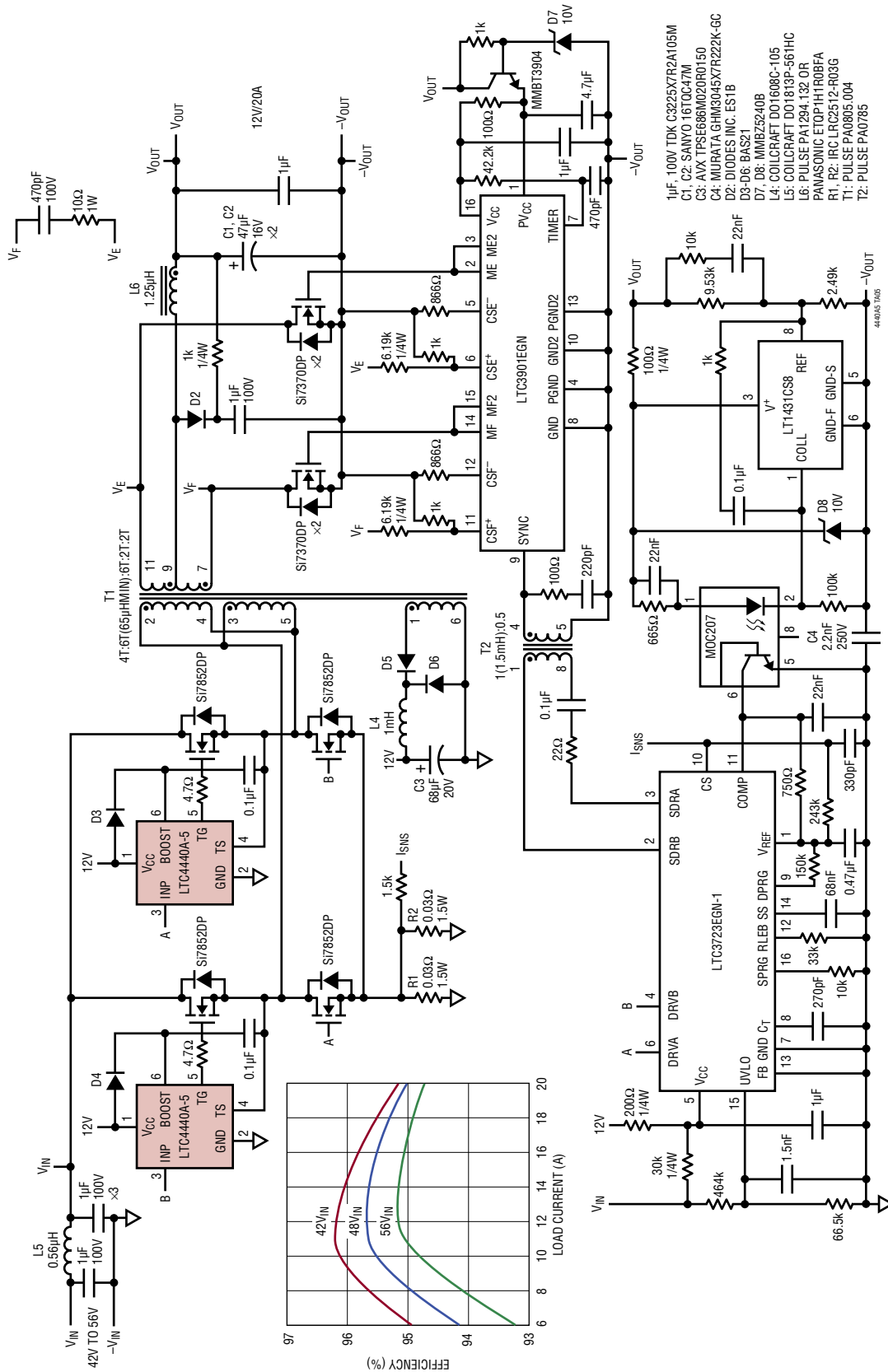

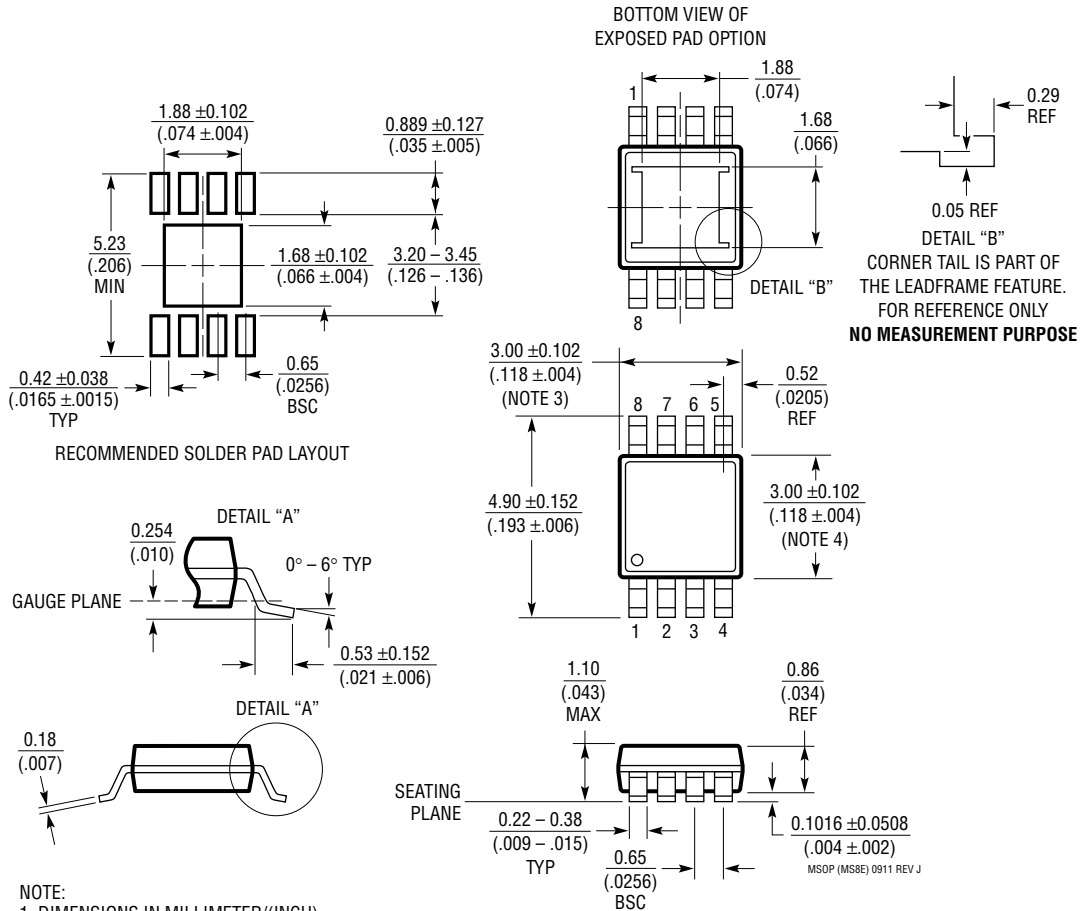

PACKAGE DESCRIPTION

MS8E Package
8-Lead Plastic MSOP, Exposed Die Pad
 (Reference LTC DWG # 05-08-1662 Rev J)



Looking for pricing, stock, or lifecycle information?

Click below to explore more details on WIN SOURCE:

-  [View LTC4440AIMS8E-5#PBF on WIN SOURCE](#)
-  [Analog Devices Inc. Information](#)

Optimize Your Supply Chain with WIN SOURCE Solutions

-  Global Sourcing Solution
-  Obsolete Management
-  Cost Control Management
-  Shortage Management
-  Alternative Solution
-  Excess Inventory Management