



## 100V Overvoltage, Undervoltage and Reverse Supply Protection Controller

### FEATURES

- Wide Operating Voltage Range: 2.5V to 60V
- Overvoltage Protection to 100V
- Reverse Supply Protection to -40V
- LTC4367: Blocks 50Hz and 60Hz AC Power
- LTC4367: 32ms Recovery from Fault
- LTC4367-1: Fast 500 $\mu$ s Recovery from Fault
- No Input Capacitor or TVS Required for Most Applications
- Adjustable Undervoltage and Overvoltage Thresholds
- Controls Back-to-Back N-Channel MOSFETs
- Low Operating Current: 70 $\mu$ A
- Low Shutdown Current: 5 $\mu$ A
- 8-Pin MSOP and 3mm  $\times$  3mm DFN Packages

### APPLICATIONS

- Portable Instrumentation
- Industrial Automation
- Automotive Surge (Load Dump) Protection
- Network Equipment

### DESCRIPTION

The LTC<sup>®</sup>4367 protects applications where power supply input voltages may be too high, too low or even negative. It does this by controlling the gate voltages of a pair of external N-channel MOSFETs to ensure that the output stays within a safe operating range. The LTC4367 withstands voltages between -40V and 100V and has an operating range of 2.5V to 60V, while consuming only 70 $\mu$ A in normal operation.

Two comparator inputs allow configuration of the overvoltage (OV) and undervoltage (UV) set points using an external resistive divider. A shutdown pin provides external control for enabling and disabling the MOSFETs as well as placing the device in a low current shutdown state. A fault output indicates that the GATE pin is pulling low when the part is in shutdown or the input voltage is outside the UV and OV set points.

The LTC4367 has a 32ms turn-on delay that debounces live connections and blocks 50Hz to 60Hz AC power. For fast recovery after faults, the LTC4367-1 has a reduced turn-on delay of 500 $\mu$ s.

LT, LT, LTC, LTM, Linear Technology and the Linear logo are registered trademarks and ThinSOT is a trademark of Analog Devices, Inc. All other trademarks are the property of their respective owners.

### TYPICAL APPLICATION

24V Automotive Application with +100V, -40V Protection

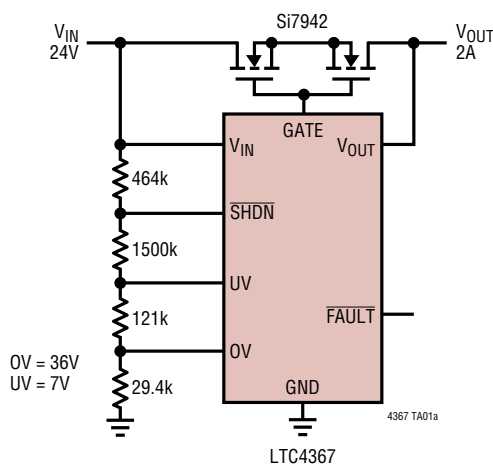

Load Protected from Reverse and Overvoltage at VIN

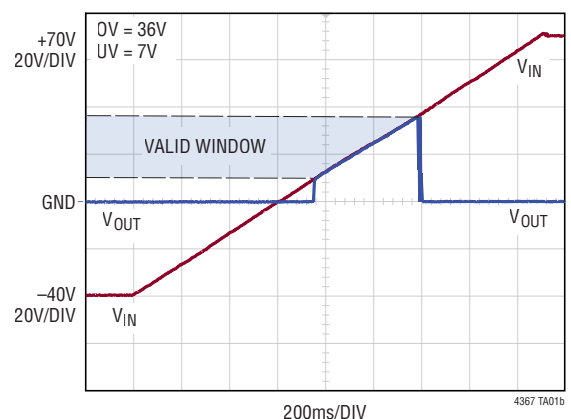

## ABSOLUTE MAXIMUM RATINGS

(Note 1, Note 2)

### Supply Voltage

$V_{IN}$  ..... -40V to 100V

### Input Voltages (Note 3)

UV, SHDN ..... -0.3V to 80V

OV ..... -0.3V to 5V

$V_{OUT}$  ..... -0.3V to 80V

### Output Voltages

FAULT ..... -0.3V to 80V

GATE (Note 4) ..... -40V to 75V

### Input Currents

SHDN, UV ..... -1mA

OV ..... -1mA

### Operating Ambient Temperature Range

LTC4367C ..... 0°C to 70°C

LTC4367I ..... -40°C to 85°C

LTC4367H ..... -40°C to 125°C

### Storage Temperature Range

Lead Temperature (Soldering, 10sec)

for MSOP Only ..... 300°C

## PIN CONFIGURATION

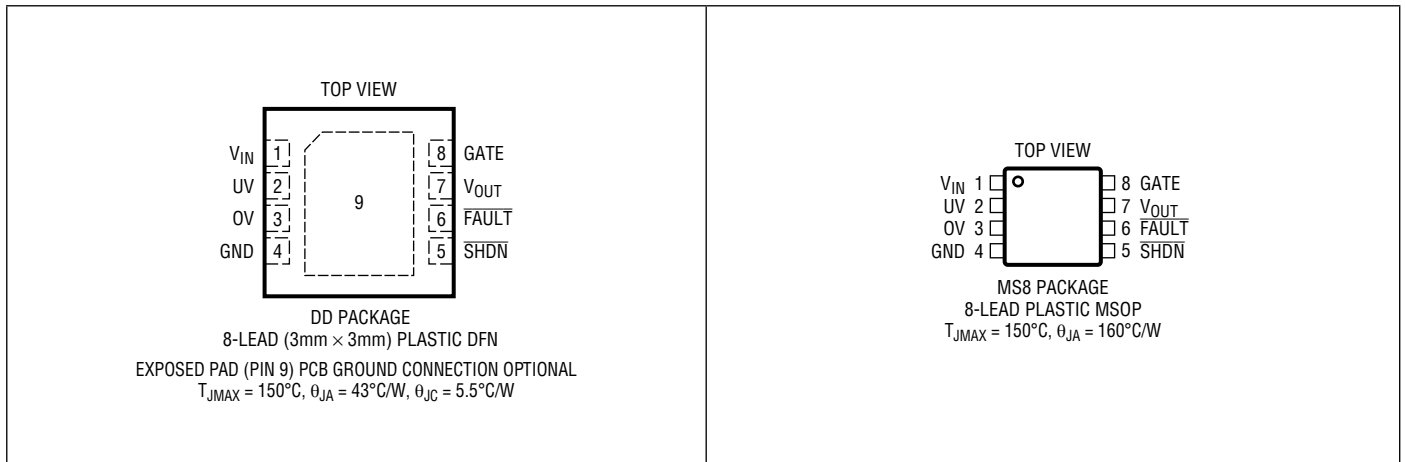

## ORDER INFORMATION <http://www.linear.com/product/LTC4367#orderinfo>

LEAD FREE FINISH	TAPE AND REEL	PART MARKING*	PACKAGE DESCRIPTION	TEMPERATURE RANGE
LTC4367CDD#PBF	LTC4367CDD#TRPBF	LGTF	8-Lead (3mm × 3mm) Plastic DFN	0°C to 70°C
LTC4367CDD-1#PBF	LTC4367CDD-1#TRPBF	LGVW	8-Lead (3mm × 3mm) Plastic DFN	0°C to 70°C
LTC4367IDD#PBF	LTC4367IDD#TRPBF	LGTF	8-Lead (3mm × 3mm) Plastic DFN	-40°C to 85°C
LTC4367IDD-1#PBF	LTC4367IDD-1#TRPBF	LGVW	8-Lead (3mm × 3mm) Plastic DFN	-40°C to 85°C
LTC4367HDD#PBF	LTC4367HDD#TRPBF	LGTF	8-Lead (3mm × 3mm) Plastic DFN	-40°C to 125°C
LTC4367HDD-1#PBF	LTC4367HDD-1#TRPBF	LGVW	8-Lead (3mm × 3mm) Plastic DFN	-40°C to 125°C
LTC4367CMS8#PBF	LTC4367CMS8#TRPBF	LTGTD	8-Lead Plastic MSOP	0°C to 70°C
LTC4367CMS8-1#PBF	LTC4367CMS8-1#TRPBF	LTGVX	8-Lead Plastic MSOP	0°C to 70°C
LTC4367IMS8#PBF	LTC4367IMS8#TRPBF	LTGTD	8-Lead Plastic MSOP	-40°C to 85°C
LTC4367IMS8-1#PBF	LTC4367IMS8-1#TRPBF	LTGVX	8-Lead Plastic MSOP	-40°C to 85°C
LTC4367HMS8#PBF	LTC4367HMS8#TRPBF	LTGTD	8-Lead Plastic MSOP	-40°C to 125°C
LTC4367HMS8-1#PBF	LTC4367HMS8-1#TRPBF	LTGVX	8-Lead Plastic MSOP	-40°C to 125°C

Consult LTC Marketing for parts specified with wider operating temperature ranges. \*The temperature grade is identified by a label on the shipping container.

For more information on lead free part marking, go to: <http://www.linear.com/leadfree/>

For more information on tape and reel specifications, go to: <http://www.linear.com/tapeandreeel/>. Some packages are available in 500 unit reels through designated sales channels with #TRMPBF suffix.

## ELECTRICAL CHARACTERISTICS

The ● denotes the specifications which apply over the full operating temperature range, otherwise specifications are at  $T_A = 25^\circ\text{C}$ .  $V_{IN} = 2.5\text{V to }60\text{V}$ , unless otherwise noted. (Note 2)

SYMBOL	PARAMETER	CONDITIONS	MIN	TYP	MAX	UNITS
<b><math>V_{IN}</math>, <math>V_{OUT}</math></b>						
$V_{IN}$	Input Voltage: Operating Range Protection Range		● ●	2.5 -40	60 100	V V
$V_{IN(UVLO)}$	Input Supply Undervoltage Lockout	$V_{IN}$ Rising	●	1.8	2.2 2.4	V
$I_{VIN}$	Input Supply Current: On Off	$\overline{\text{SHDN}} = 2.5\text{V}$ $\overline{\text{SHDN}} = 0\text{V}$ , $V_{IN} = V_{OUT}$	● ●	30 5	90 20	$\mu\text{A}$ $\mu\text{A}$
$I_{VIN(R)}$	Reverse Input Supply Current	$V_{IN} = -40\text{V}$ , $V_{OUT} = 0\text{V}$	●	-1.5	-2.5	mA
$I_{VOUT}$	$V_{OUT}$ Input Current: On Off Reverse	$\overline{\text{SHDN}} = 2.5\text{V}$ , $V_{IN} = V_{OUT}$ $\overline{\text{SHDN}} = 0\text{V}$ , $V_{IN} = V_{OUT}$ $V_{IN} = -40\text{V}$ , $V_{OUT} = 0\text{V}$	● ● ●	40 3 20	110 15 50	$\mu\text{A}$ $\mu\text{A}$ $\mu\text{A}$
<b>GATE</b>						
$\Delta V_{GATE}$	Gate Drive ( $GATE - V_{OUT}$ )	$V_{IN} = V_{OUT} = 5.0\text{V}$ , $I_{GATE} = 0\mu\text{A}$ , $-1\mu\text{A}$ $V_{IN} = V_{OUT} = 12\text{V to }60\text{V}$ , $I_{GATE} = 0\mu\text{A}$ , $-1\mu\text{A}$	● ●	7.2 10	8.7 11 10.8 13.1	V V
$I_{GATE(UP)}$	Gate Pull Up Current	$GATE = 15\text{V}$ , $V_{IN} = V_{OUT} = 12\text{V}$	●	-20	-35 -60	$\mu\text{A}$
$I_{GATE(SLOW)}$	Gate Slow Pull Down Current	$GATE = 20\text{V}$ , $V_{IN} = V_{OUT} = 12\text{V}$	●	50	90 160	$\mu\text{A}$
$I_{GATE(FAST)}$	Gate Fast Pull Down Current	$GATE = 20\text{V}$ , $V_{IN} = V_{OUT} = 12\text{V}$	●	30	60 90	mA
$t_{GATE(SLOW)}$	Slow Turn Off Delay	$C_{GATE} = 2.2\text{nF}$ , $\overline{\text{SHDN}}$ Falling, $V_{IN} = V_{OUT} = 12\text{V}$	●	150	250 575	$\mu\text{s}$
$t_{GATE(FAST)}$	Gate Fast Turn Off Delay	$C_{GATE} = 2.2\text{nF}$ , UV or OV Fault	●	2	6	$\mu\text{s}$

## ELECTRICAL CHARACTERISTICS

The ● denotes the specifications which apply over the full operating temperature range, otherwise specifications are at  $T_A = 25^\circ\text{C}$ .  $V_{IN} = 2.5\text{V}$  to  $60\text{V}$ , unless otherwise noted. (Note 2)

SYMBOL	PARAMETER	CONDITIONS	MIN	TYP	MAX	UNITS	
$t_{D(ON)}$	GATE Turn-On Delay Time	$V_{IN} = 12\text{V}$ , Power Good to $\Delta V_{GATE} > 0\text{V}$ , $C_{GATE} = 2.2\text{nF}$ LTC4367 LTC4367-1	● ●	22 0.2	32 0.5	45 1.2	ms ms
<b>UV, OV</b>							
$V_{UV}$	UV Input Threshold Voltage	UV Falling	●	492.5	500	507.5	mV
$V_{OV}$	OV Input Threshold Voltage	OV Rising	●	492.5	500	507.5	mV
$V_{UVHYST}$	UV Input Hysteresis	$V_{IN} = V_{OUT} = 12\text{V}$	●	20	25	32	mV
$V_{OVHYST}$	OV Input Hysteresis	$V_{IN} = V_{OUT} = 12\text{V}$	●	20	25	32	mV
$I_{LEAK}$	UV, OV Leakage Current	$V = 0.5\text{V}$ , $V_{IN} = 60\text{V}$	●			±10	nA
$t_{FAULT}$	UV, OV Fault Propagation Delay	Overdrive = $50\text{mV}$ $V_{IN} = V_{OUT} = 12\text{V}$	●		1	2	μs
<b>SHDN</b>							
$V_{SHDN}$	SHDN Input Threshold	SHDN Falling	●	0.4	0.75	1.2	V
$I_{SHDN}$	SHDN Input Current	SHDN = $10\text{V}$ , $V_{IN} = 60\text{V}$	●			±15	nA
$t_{START}$	Delay Coming Out of Shutdown Mode	SHDN Rising to $\overline{\text{FAULT}}$ Released, $V_{IN} = V_{OUT} = 12\text{V}$ LTC4367 LTC4367-1	●	400 125	800 250	1400 500	μs μs
$t_{SHDN(F)}$	SHDN to $\overline{\text{FAULT}}$ Asserted	$V_{IN} = V_{OUT} = 12\text{V}$	●		1.5	3	μs
$t_{LOWPWR}$	Delay from Turn Off to Low Power Operation	$V_{IN} = V_{OUT} = 12\text{V}$ LTC4367 LTC4367-1	● ●	20 0.125	32 0.3	48 0.6	ms ms
<b>FAULT</b>							
$V_{OL}$	$\overline{\text{FAULT}}$ Output Voltage Low	$I_{FAULT} = 500\mu\text{A}$ , $V_{IN} = 12\text{V}$	●		0.15	0.4	V
$I_{FAULT}$	$\overline{\text{FAULT}}$ Leakage Current	$\overline{\text{FAULT}} = 5\text{V}$ , $V_{IN} = 60\text{V}$	●			±200	nA

**Note 1.** Stresses beyond those listed under Absolute Maximum Ratings may cause permanent damage to the device. Exposure to any Absolute Maximum Rating condition for extended periods may affect device reliability and lifetime.

**Note 2.** All currents into pins are positive; all voltages are referenced to GND unless otherwise noted.

**Note 3.** These pins have a diode to GND. They may go below  $-0.3\text{V}$  if the current magnitude is limited to less than  $1\text{mA}$ .

**Note 4.** The GATE pin is referenced to  $V_{OUT}$  and does not exceed  $73\text{V}$  for the entire operating range.

# TYPICAL PERFORMANCE CHARACTERISTICS

**$V_{IN}$  Operating Current vs Temperature**

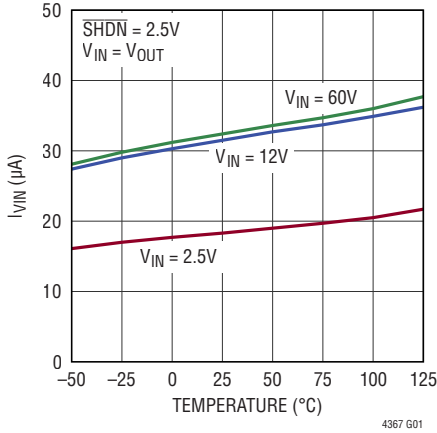

**$V_{IN}$  Shutdown Current vs Voltage**

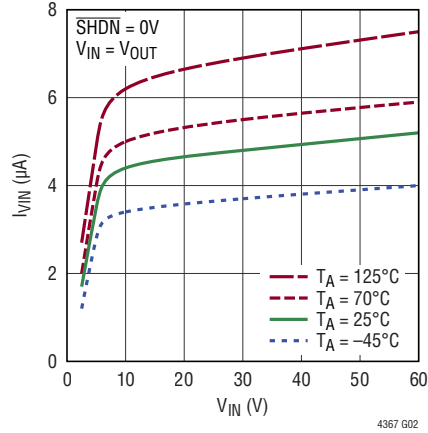

**$V_{IN}$  Supply Current vs Voltage (-40V to 100V)**

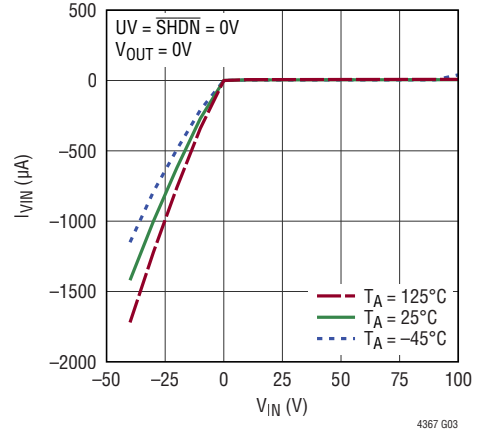

**$V_{OUT}$  Operating Current vs Temperature**

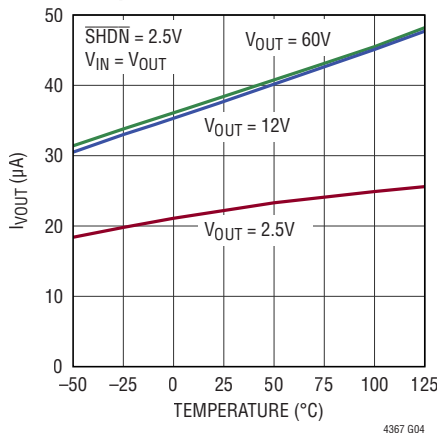

**$V_{OUT}$  Shutdown Current vs Temperature**

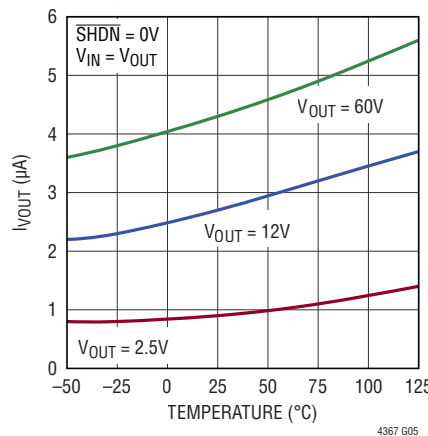

**$V_{OUT}$  Current vs Reverse  $V_{IN}$**

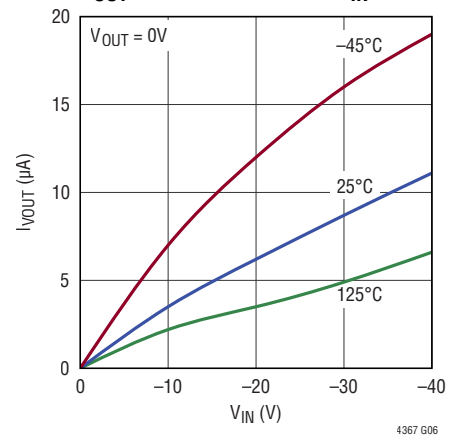

**GATE Drive vs  $V_{IN}$  Supply Voltage**

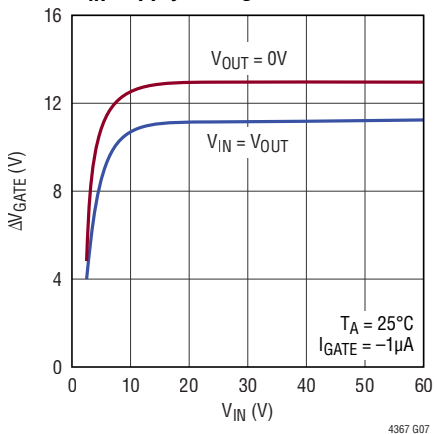

**GATE Drive vs Temperature**

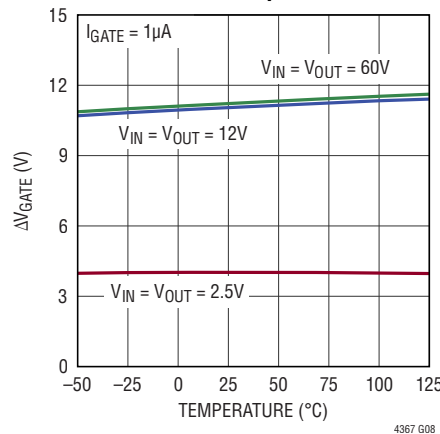

**GATE Drive vs GATE Current**

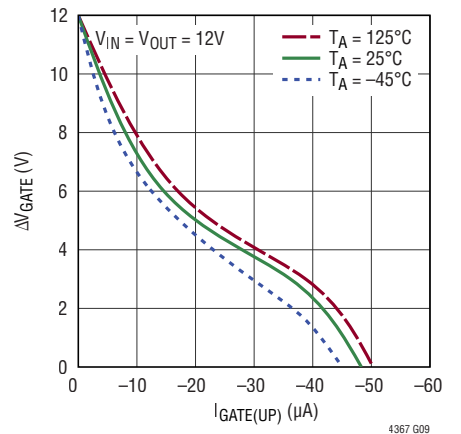

## TYPICAL PERFORMANCE CHARACTERISTICS

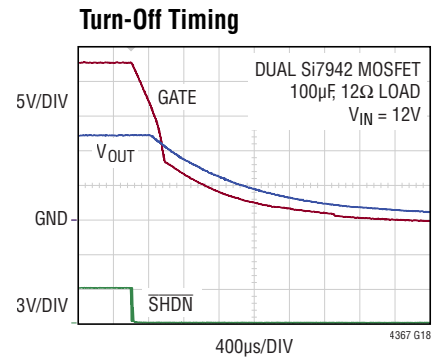
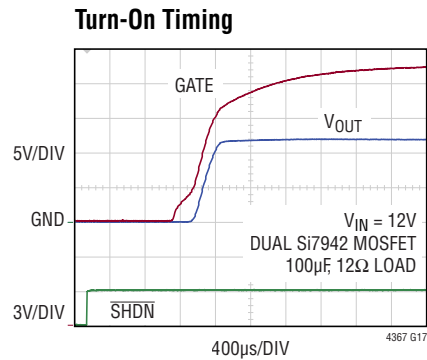
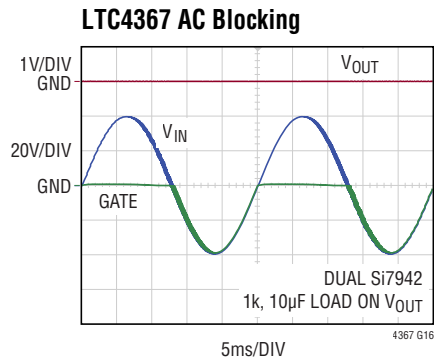
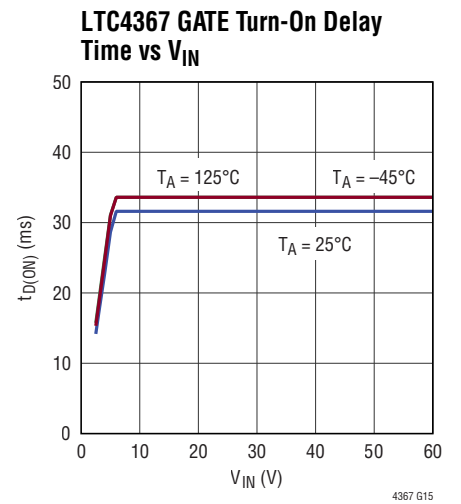
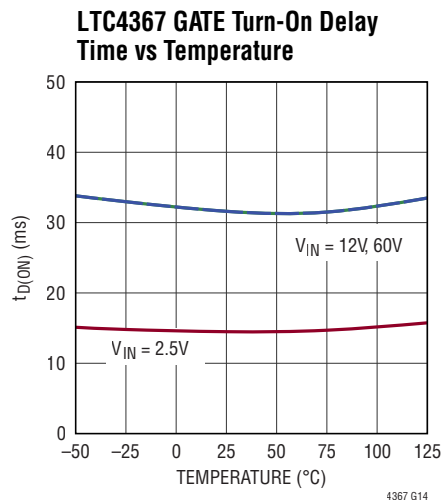
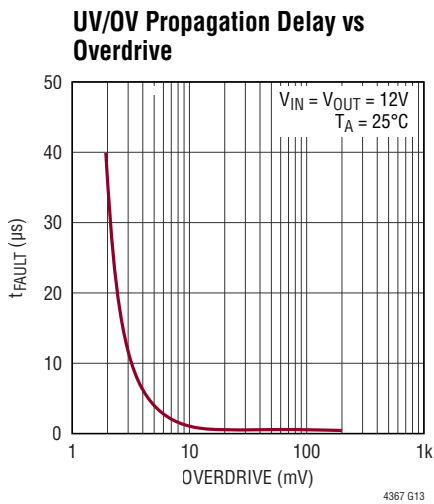
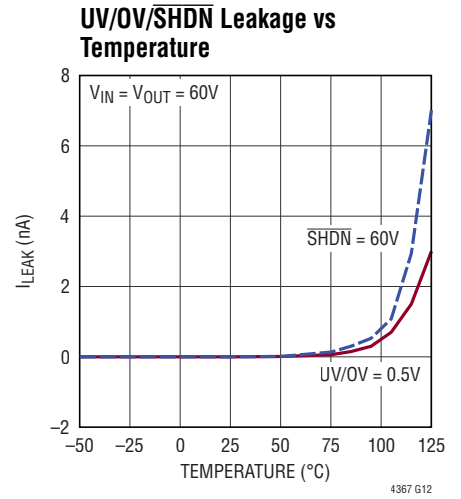
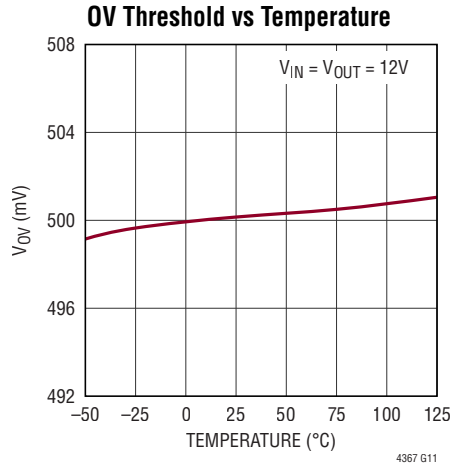
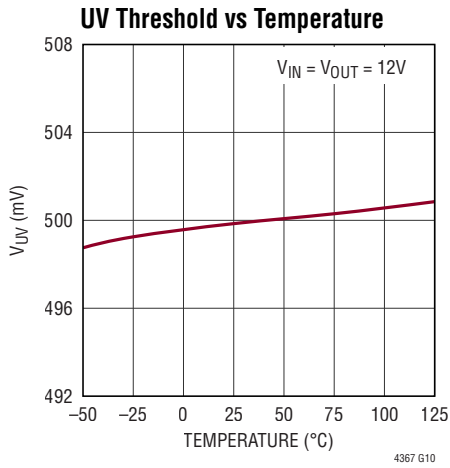

## PIN FUNCTIONS

**Exposed Pad:** The exposed pad may be left open or connected to device ground.

**FAULT:** Fault Indication Output. This high voltage open drain output is pulled low if UV is below its monitor threshold, if OV is above its monitor threshold, if  $\overline{\text{SHDN}}$  is low, or if  $V_{\text{IN}}$  has not risen above  $V_{\text{IN(UVLO)}}$ .

**GATE:** Gate Drive Output for External N-channel MOSFETs. An internal charge pump provides 35 $\mu\text{A}$  of pull-up current and up to 13.1V of enhancement to the gate of an external N-channel MOSFET. When turned off, GATE is pulled just below the lower of  $V_{\text{IN}}$  or  $V_{\text{OUT}}$ . When  $V_{\text{IN}}$  goes negative, GATE is automatically connected to  $V_{\text{IN}}$ .

**GND:** Device Ground.

**OV:** Overvoltage Comparator Input. Connect this pin to an external resistive divider to set the desired  $V_{\text{IN}}$  overvoltage fault threshold. This input connects to an accurate, fast (1 $\mu\text{s}$ ) comparator with a 0.5V rising threshold and 25mV of hysteresis. When OV rises above its threshold, a 60mA current sink pulls down on the GATE output. When OV falls back below 0.475V, and after a 32ms GATE turn-on delay waiting period (500 $\mu\text{s}$  for LTC4367-1), the GATE charge pump is enabled. The low leakage current of the OV input allows the use of large valued resistors for the external resistive divider. Connect to GND if unused. If the voltage at the OV pin can rise above 5V, place a low leakage Zener clamp on the OV pin.

**SHDN:** Shutdown Control Input.  $\overline{\text{SHDN}}$  high enables the GATE charge pump which in turn enhances the gate of an external N-channel MOSFET. A low on  $\overline{\text{SHDN}}$  generates a pull down on the GATE output with a 90 $\mu\text{A}$  current sink and places the LTC4367 in low current mode (5 $\mu\text{A}$ ). If unused, connect to  $V_{\text{IN}}$  with a 510k resistor. If  $V_{\text{IN}}$  goes above 80V, the SHDN pin voltage must be kept below 80V (see Applications Information).

**UV:** Undervoltage Comparator Input. Connect this pin to an external resistive divider to set the desired  $V_{\text{IN}}$  undervoltage fault threshold. This input connects to an accurate, fast (1 $\mu\text{s}$ ) comparator with a 0.5V falling threshold and 25mV of hysteresis. When UV falls below its threshold, a 60mA current sink pulls down on the GATE output. When UV rises back above 0.525V, and after a 32ms GATE turn-on delay waiting period (500 $\mu\text{s}$  for LTC4367-1), the GATE charge pump is enabled. The low leakage current of the UV input allows the use of large valued resistors for the external resistive divider. If unused and  $V_{\text{IN}}$  is less than 80V, connect to  $V_{\text{IN}}$  with a 510k resistor.

**V<sub>IN</sub>:** Power Supply Input. Maximum protection range: -40V to 100V. Operating range: 2.5V to 60V.

**V<sub>OUT</sub>:** Output Voltage Sense Input. This pin senses the voltage at the output side of the external N-channel MOSFET. The GATE charge pump voltage is referenced to  $V_{\text{OUT}}$ . It is used as the charge pump input when  $V_{\text{OUT}}$  is greater than approximately 5V.

**BLOCK DIAGRAM**

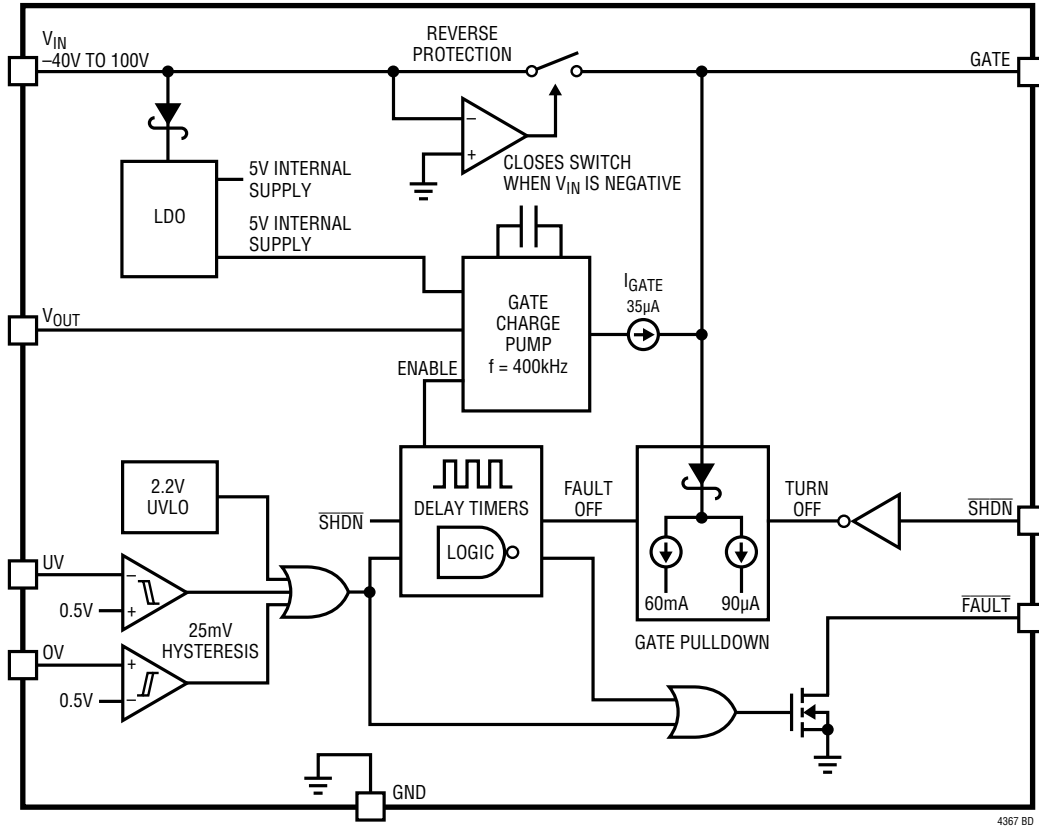

4367 BD

## OPERATION

Many of today's electronic systems get their power from external sources such as AC or wall adaptors, batteries and custom power supplies. Figure 1 shows a supply arrangement using a DC barrel connector. Power is supplied by an AC adaptor or, if the plug is withdrawn, by a removable battery. Note that the polarity of the AC adaptor and barrel connector varies by manufacturer. Trouble arises when any of the following occurs:

- The battery is installed backwards
- An AC adaptor of opposite polarity is attached
- An AC adaptor of excessive voltage is attached
- The battery is discharged below a safe level

This can lead to supply voltages that are too high, too low, or even negative. If these power sources are applied directly to the electronic systems, the systems could be subject to damage. The LTC4367 is an input voltage fault protection N-channel MOSFET controller. The part isolates an input supply from its load to protect the load from

unexpected supply voltage conditions, while providing a low loss path for qualified power.

In the past, to protect electronic systems from improperly connected power supplies, system designers often added discrete diodes, transistors and high voltage comparators. The high voltage comparators enable system power only if the input supply falls within a desired voltage window. A Schottky diode or P-channel MOSFET typically added in series with the supply protects against reverse supply connections.

The LTC4367 provides accurate overvoltage and undervoltage comparators to ensure that power is applied to the system only if the input supply meets the user selectable voltage window. Reverse supply protection circuits automatically isolate the load from negative input voltages. During normal operation, a high voltage charge pump enhances the gate of external N-channel power MOSFETs. Power consumption is 5 $\mu$ A during shutdown and 70 $\mu$ A while operating. The LTC4367 integrates all these functions in 8-lead MSOP and 3mm  $\times$  3mm DFN packages.

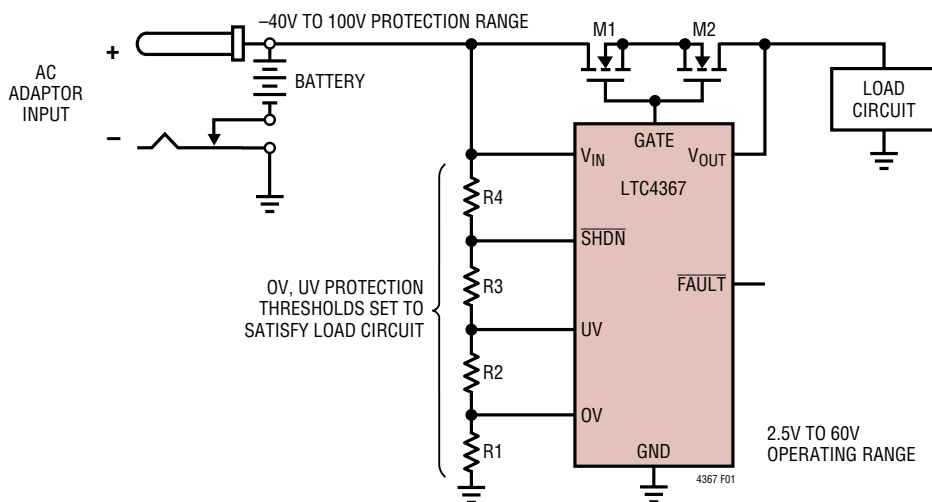
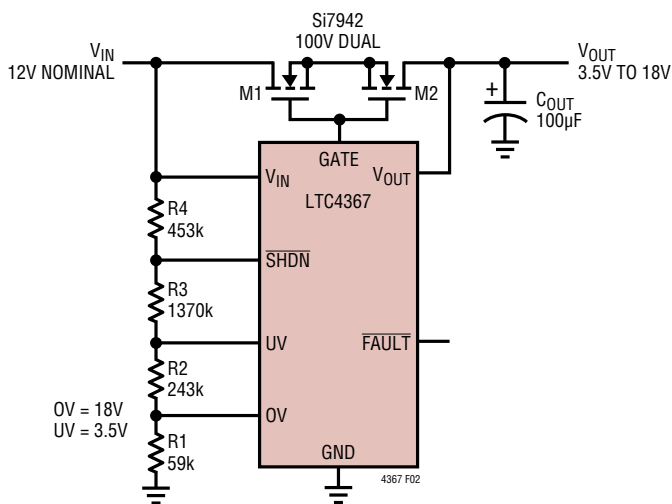

Figure 1. Polarity Protection for DC Barrel Connectors

## APPLICATIONS INFORMATION

The LTC4367 is an N-channel MOSFET controller that protects a load from faulty supply connections. A basic application circuit using the LTC4367 is shown in Figure 2. The circuit provides a low loss connection from  $V_{IN}$  to  $V_{OUT}$  as long as the voltage at  $V_{IN}$  is between 3.5V and 18V. Voltages at  $V_{IN}$  outside of the 3.5V to 18V range are prevented from getting to the load and can be as high as 100V and as low as  $-40V$ . The circuit of Figure 2 protects against negative voltages at  $V_{IN}$  as shown. No other external components are needed.

During normal operation, the LTC4367 provides up to 13.1V of gate enhancement to the external back-to-back N-channel MOSFETs. This turns on the MOSFETs, thus connecting the load at  $V_{OUT}$  to the supply at  $V_{IN}$ .



**Figure 2. LTC4367 Protects Load from  $-40V$  to  $100V$   $V_{IN}$  Faults**

### GATE Drive

The LTC4367 turns on the external N-channel MOSFETs by driving the GATE pin above  $V_{OUT}$ . The voltage difference between the GATE and  $V_{OUT}$  pins (gate drive) is a function of  $V_{IN}$  and  $V_{OUT}$ .

Figure 3 highlights the dependence of the gate drive on  $V_{IN}$  and  $V_{OUT}$ . When system power is first turned on (SHDN low to high,  $V_{OUT} = 0V$ ), gate drive is at a maximum for all values of  $V_{IN}$ . This helps prevent start-up problems into heavy loads by ensuring that there is enough gate drive to support the load.

As  $V_{OUT}$  ramps up from  $0V$ , the absolute value of the GATE voltage remains fixed until  $V_{OUT}$  is greater than the lower of  $(V_{IN} - 1V)$  or  $5V$ . Once  $V_{OUT}$  crosses this threshold, gate drive begins to increase up to a maximum of 13.1V (for  $V_{IN} \geq 12V$ ). The curves of Figure 3 were taken with a GATE load of  $-1\mu A$ . If there were no load on GATE, the gate drive for each  $V_{IN}$  would be slightly higher.

Note that when  $V_{IN}$  is at the lower end of the operating range, the external N-channel MOSFET must be selected with a corresponding lower threshold voltage.

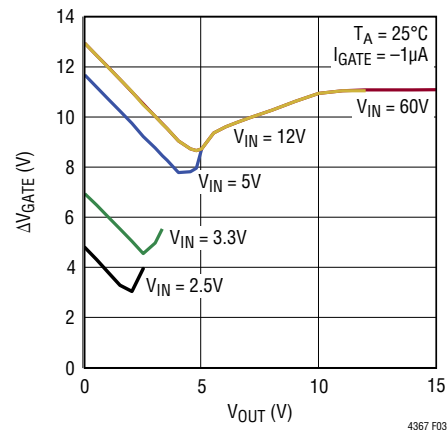

**Figure 3. Gate Drive (GATE –  $V_{OUT}$ ) vs  $V_{OUT}$**

## APPLICATIONS INFORMATION

Table 1 lists some external MOSFETs compatible with different  $V_{IN}$  supply voltages.

**Table 1. Dual MOSFETs for Various Supply Ranges**

$V_{IN}$	MOSFET	$V_{TH(MAX)}$	$V_{GS(MAX)}$	$V_{DS(MAX)}$	$R_{DS(ON)}$ ( $\Omega$ )
2.5V	SiA920	0.7V	5V	8V	0.027
3.3V	SiA910	1.0V	8V	12V	0.028
3.3V	Si6926	1.0V	8V	20V	0.030
5V	SiA906	1.4V	12V	20V	0.046
5V	Si9926	1.5V	12V	20V	0.018
>12V	SiZ340	2.4V	20V	30V	0.010
>12V	Si4288	2.5V	20V	40V	0.020
>12V	Si7220	3V	20V	60V	0.060
>12V	Si4946	3V	20V	60V	0.040
>12V	FDS3890	4V	20V	80V	0.044
>12V	Si7942	4V	20V	100V	0.049
>12V	FDS3992	4V	20V	100V	0.054
>12V	Si7956	4V	20V	150V	0.105

### Overvoltage and Undervoltage Protection

The LTC4367 provides two accurate comparators to monitor for overvoltage (OV) and undervoltage (UV) conditions at  $V_{IN}$ . If the input supply rises above the user adjustable OV threshold, the gate of the external MOSFET is quickly turned off, thus disconnecting the load from the input. Similarly, if the input supply falls below the user adjustable UV threshold, the gate of the external MOSFET also is quickly turned off. Figure 4 shows a UV/OV application for an input supply of 12V.

The external resistive divider allows the user to select an input supply range that is compatible with the load at  $V_{OUT}$ . Furthermore, the UV and OV inputs have very low leakage currents (typically  $< 1nA$  at  $100^{\circ}C$ ), allowing for large values in the external resistive divider. In the application of Figure 4, the load is connected to the supply only if  $V_{IN}$  lies between 3.5V and 18V. In the event that  $V_{IN}$  goes above 18V or below 3.5V, the gate of the external N-channel MOSFET is immediately discharged with a 60mA current sink, thus isolating the load from the supply.

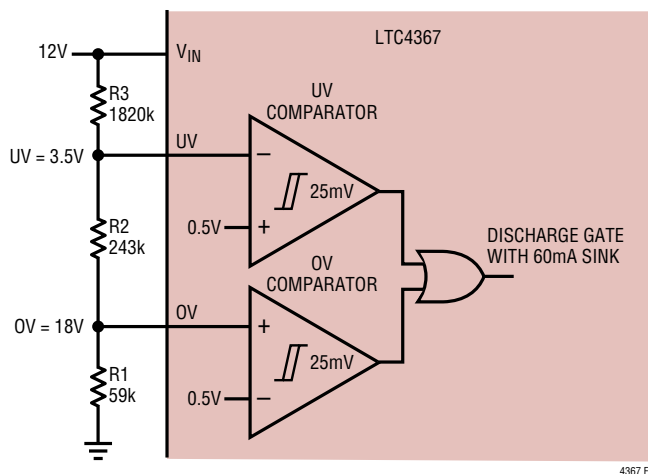

**Figure 4. UV, OV Comparators Monitor 12V Supply**

## APPLICATIONS INFORMATION

Figure 5 shows the timing associated with the UV pin. Once a UV fault propagates through the UV comparator ( $t_{\text{FAULT}}$ ), the  $\overline{\text{FAULT}}$  output is asserted low and a 60mA current sink discharges the GATE pin. As  $V_{\text{OUT}}$  falls, the GATE pin tracks  $V_{\text{OUT}}$ .

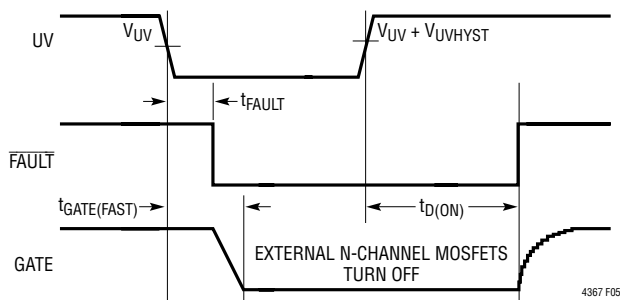

**Figure 5. UV Timing ( $OV < (V_{OV} - V_{OVHYST})$ ,  $\overline{\text{SHDN}} > 1.2V$ )**

Figure 6 shows the timing associated with the OV pin. Once an OV fault propagates through the OV comparator ( $t_{\text{FAULT}}$ ), the  $\overline{\text{FAULT}}$  output is asserted low and a 60mA current sink discharges the GATE pin. As  $V_{\text{OUT}}$  falls, the GATE pin tracks  $V_{\text{OUT}}$ .

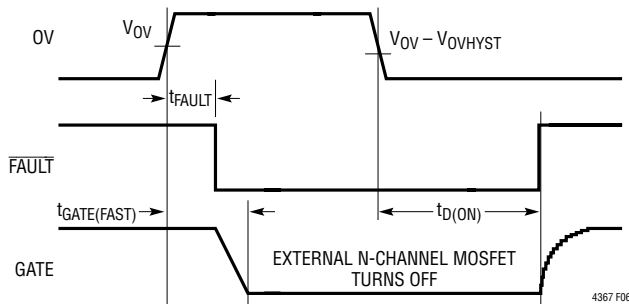

**Figure 6. OV Timing ( $UV > (V_{UV} + V_{UVHYST})$ ,  $\overline{\text{SHDN}} > 1.2V$ )**

When both the UV and OV faults are removed, the external MOSFET is not immediately turned on. The input supply must remain within the user selected power good window for at least 32ms ( $t_{D(ON)}$ ) before the load is again connected to the supply. This GATE turn-on delay period filters noise (including line noise) at the input supply and prevents chattering of power at the load. For applications that require faster turn-on after a fault, the LTC4367-1 provides a 500 $\mu$ s GATE turn-on delay.

### Procedure for Selecting UV/OV External Resistor Values

The following 3-step procedure helps select the resistor values for the resistive divider of Figure 4. This procedure minimizes UV and OV offset errors caused by leakage currents at the respective pins.

1. Choose maximum tolerable offset error at the UV pin,  $V_{OS(UV)}$ . Divide by the worst case leakage current at the UV pin,  $I_{LEAK}$  (10nA). Set the sum of  $R1 + R2$  equal to  $V_{OS(UV)}$  divided by 10nA. Note that due to the presence of  $R3$ , the actual offset at UV will be slightly lower:

$$R1 + R2 \leq \frac{V_{OS(UV)}}{I_{LEAK}}$$

2. Select the desired  $V_{IN}$  UV trip threshold,  $UV_{TH}$ . Find the value of  $R3$ :

$$R3 = \frac{V_{OS(UV)}}{I_{LEAK}} \cdot \left( \frac{UV_{TH} - 0.5V}{0.5V} \right)$$

3. Select the desired  $V_{IN}$  OV trip threshold,  $OV_{TH}$ . Find the values of  $R1$  and  $R2$ :

$$R1 = \frac{\left( \frac{V_{OS(UV)}}{I_{LEAK}} \right) + R3}{OV_{TH}} \cdot 0.5V$$

$$R2 = \frac{V_{OS(UV)}}{I_{LEAK}} - R1$$

The example of Figure 4 uses standard 1% resistor values. The following parameters were selected:

$$V_{OS(UV)} = 3mV$$

$$I_{LEAK} = 10nA$$

$$UV_{TH} = 3.5V$$

$$OV_{TH} = 18V$$

## APPLICATIONS INFORMATION

The resistor values can then be solved:

$$1. R1 + R2 = \frac{3\text{mV}}{10\text{nA}} = 300\text{k}$$

$$2. R3 = \frac{3\text{mV}}{10\text{nA}} \cdot \frac{(3.5\text{V} - 0.5\text{V})}{0.5\text{V}} = 1.8\text{M}$$

The closest 1% value:  $R3 = 1.82\text{M}$ :

$$3. R1 = \frac{300\text{k} + 1.82\text{M}}{2 \cdot 18\text{V}} = 58.9\text{k}$$

The closest 1% value:  $R1 = 59\text{k}$ :

$$R2 = 300\text{k} - 59\text{k} = 241\text{k}$$

The closest 1% value:  $R2 = 243\text{k}$

Therefore:  $\text{OV} = 17.93\text{V}$ ,  $\text{UV} = 3.51\text{V}$ .

### Reverse $V_{\text{IN}}$ Protection

The LTC4367's rugged and hot-swappable  $V_{\text{IN}}$  input helps protect the more sensitive circuits at the output load. If the input supply is plugged in backwards, or a negative supply is inadvertently connected, the LTC4367 prevents this negative voltage from passing to the output load.

The LTC4367 employs a novel, high speed reverse supply voltage monitor. When the negative  $V_{\text{IN}}$  voltage is detected, an internal switch connects the gates of the external back-to-back N-channel MOSFETs to the negative input supply.

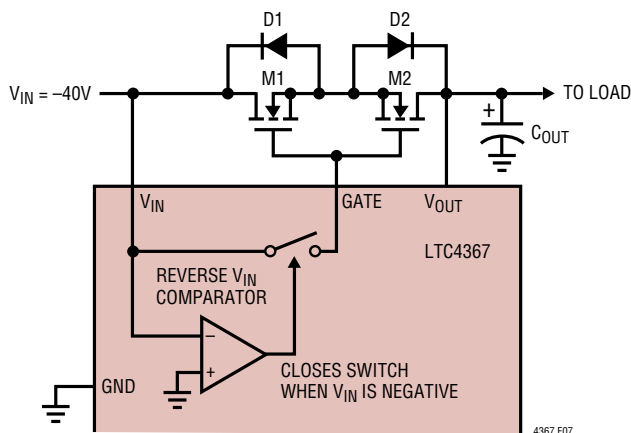

Figure 7. Reverse  $V_{\text{IN}}$  Protection Circuits

As shown in Figure 7, external back-to-back N-channel MOSFETs are required for reverse supply protection. When  $V_{\text{IN}}$  goes negative, the reverse  $V_{\text{IN}}$  comparator closes the internal switch, which in turn connects the gates of the external MOSFETs to the negative  $V_{\text{IN}}$  voltage. The body diode (D1) of M1 turns on, but the body diode (D2) of M2 remains in reverse blocking mode. This means that the common source connection of M1 and M2 remains about a diode drop higher than  $V_{\text{IN}}$ . Since the gate voltage of M2 is shorted to  $V_{\text{IN}}$ , M2 will be turned off and no current can flow from  $V_{\text{IN}}$  to the load at  $V_{\text{OUT}}$ . Note that the voltage rating of M2 must withstand the reverse voltage excursion at  $V_{\text{IN}}$ .

Figure 8 illustrates the waveforms that result when  $V_{\text{IN}}$  is hot plugged to  $-20\text{V}$ .  $V_{\text{IN}}$ , GATE and  $V_{\text{OUT}}$  start out at ground just before the connection is made. Due to the parasitic inductance of the  $V_{\text{IN}}$  and GATE connections, the voltage at the  $V_{\text{IN}}$  and GATE pins ring significantly below  $-20\text{V}$ . Therefore, a 40V N-channel MOSFET was selected to survive the overshoot.

The speed of the LTC4367 reverse protection circuits is evident by how closely the GATE pin follows  $V_{\text{IN}}$  during the negative transients. The two waveforms are almost indistinguishable on the scale shown.

The trace at  $V_{\text{OUT}}$ , on the other hand, does not respond to the negative voltage at  $V_{\text{IN}}$ , demonstrating the desired reverse supply protection. The waveforms of Figure 8 were captured using a 40V dual N-channel MOSFET, a  $10\mu\text{F}$  ceramic output capacitor and no load current on  $V_{\text{OUT}}$ .

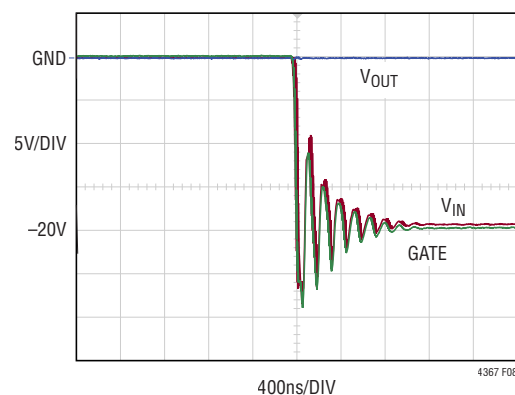

Figure 8. Hot Swapping  $V_{\text{IN}}$  to  $-20\text{V}$

## APPLICATIONS INFORMATION

### GATE Turn-On Delay Timer

The LTC4367 has a GATE turn-on delay timer that filters noise at  $V_{IN}$  and helps prevent chatter at  $V_{OUT}$ . After either an OV or UV fault has occurred, the input supply must return to the desired operating voltage window for at least 32ms ( $t_{D(ON)}$ ) in order to turn the external MOSFET back on as illustrated in Figure 5 and Figure 6. For applications that require faster turn-on after a fault, the LTC4367-1 provides a 500 $\mu$ s GATE turn-on delay.

Going out of and then back into fault in less than  $t_{D(ON)}$  will keep the MOSFET off continuously. Similarly, coming out of shutdown ( $\overline{SHDN}$  low to high) triggers an 800 $\mu$ s start-up delay timer (see Figure 11).

The GATE turn-on delay timer is also active while the part is powering up. The timer starts once  $V_{IN}$  rises above  $V_{IN(UVLO)}$  and  $V_{IN}$  lies within the user selectable UV/OV power good window. See Figure 9.

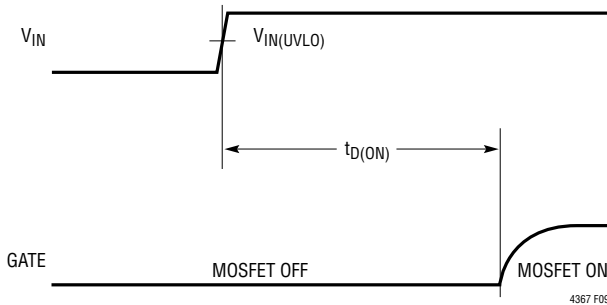

**Figure 9. GATE Turn-On Delay Timing During Power-On (OV = GND, UV =  $\overline{SHDN}$  =  $V_{IN}$ )**

### Shutdown

The  $\overline{SHDN}$  input turns off the external MOSFETs in a controlled manner. When  $\overline{SHDN}$  is asserted low, a 90 $\mu$ A current sink slowly begins to turn off the external MOSFETs.

Once the voltage at the GATE pin falls below the voltage at the  $V_{OUT}$  pin, the current sink is throttled back and a feedback loop takes over. This loop forces the GATE voltage to track  $V_{OUT}$ , thus keeping the external MOSFETs off as  $V_{OUT}$  decays. Note that when  $V_{OUT} < 2.2V$ , the GATE pin is pulled to within 400mV of ground.

Weak gate turn off reduces load current slew rates and mitigates voltage spikes due to parasitic inductances. To

further decrease GATE pin slew rate, place a capacitor across the gate and source terminals of the external MOSFETs. The waveforms of Figure 10 were captured using the Si7942 dual N-channel MOSFETs, and a 2A load with 100 $\mu$ F output capacitor.

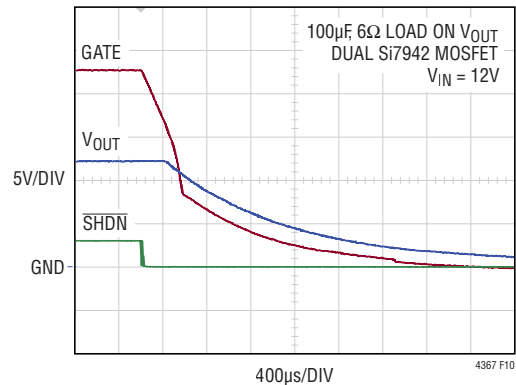

**Figure 10. Shutdown: GATE Tracks  $V_{OUT}$  as  $V_{OUT}$  Decays**

### FAULT Status

The  $\overline{FAULT}$  high voltage open drain output is driven low if  $\overline{SHDN}$  is asserted low, if  $V_{IN}$  is outside the desired UV/OV voltage window, or if  $V_{IN}$  has not risen above  $V_{IN(UVLO)}$ . Figure 5, Figure 6 and Figure 11 show the  $\overline{FAULT}$  output timing.

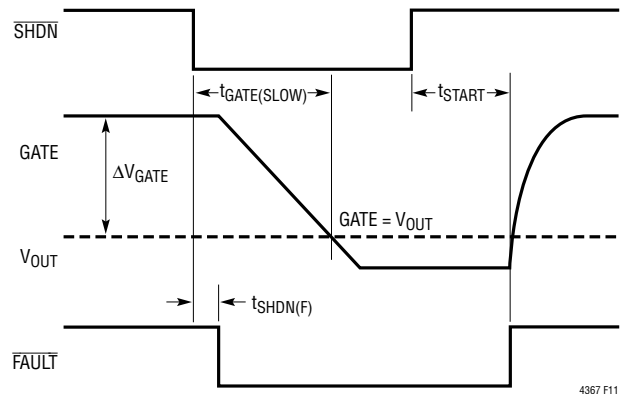

**Figure 11. Shutdown Timing**

### Select Between Two Input Supplies

With the part in shutdown, the  $V_{IN}$  and  $V_{OUT}$  pins can be driven by separate power supplies. The LTC4367 then automatically drives the GATE pin just below the lower of

## APPLICATIONS INFORMATION

the two supplies, thus turning off the external back-to-back MOSFETs. The application of Figure 12 uses two LTC4367s to select between two power supplies. Care should be taken to ensure that only one of the two LTC4367s is enabled at any given time.

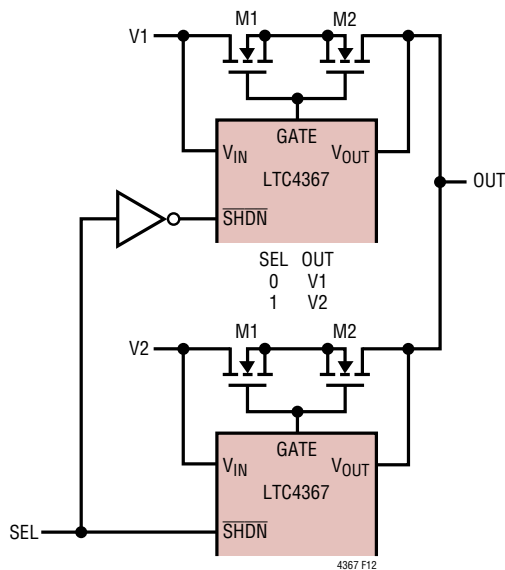

Figure 12. Selecting One of Two Supplies

### Single MOSFET Application

When reverse  $V_{IN}$  protection is not needed, a single external N-channel MOSFET may be used. The application circuit of Figure 13 connects the load to  $V_{IN}$  when  $V_{IN}$  is less than 30V, and uses the minimal set of external components.

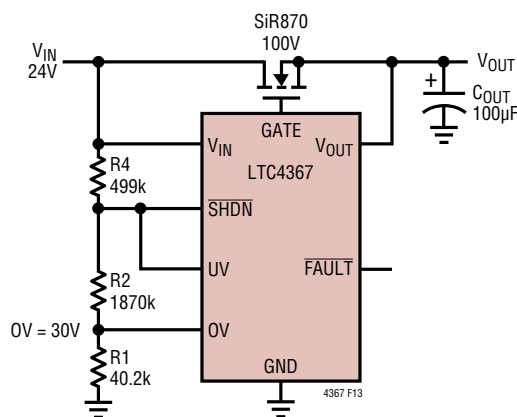

Figure 13. Single MOSFET Application Protects Against 100V

### Limiting Inrush Current During Turn-On

The LTC4367 turns on the external N-channel MOSFET with a  $35\mu\text{A}$  current source. The maximum slew rate at the GATE pin can be reduced by adding a capacitor on the GATE pin:

$$\text{Slew Rate} = \frac{35\mu\text{A}}{C_{\text{GATE}}}$$

Since the MOSFET acts like a source follower, the slew rate at  $V_{OUT}$  equals the slew rate at GATE.

Therefore, inrush current is given by:

$$I_{\text{INRUSH}} = \frac{C_{\text{OUT}}}{C_{\text{GATE}}} \cdot 35\mu\text{A}$$

For example, a 1A inrush current to a  $330\mu\text{F}$  output capacitance requires a GATE capacitance of:

$$C_{\text{GATE}} = \frac{35\mu\text{A} \cdot C_{\text{OUT}}}{I_{\text{INRUSH}}}$$

$$C_{\text{GATE}} = \frac{35\mu\text{A} \cdot 330\mu\text{F}}{1\text{A}} = 11.6\text{nF}$$

The 12nF  $C_{\text{GATE}}$  capacitor in the application circuit of Figure 14 limits the inrush current to just under 1A.  $R_{\text{GATE}}$  makes sure that  $C_{\text{GATE}}$  does not affect the fast GATE turn off characteristics during UV/OV faults, or during reverse  $V_{IN}$  connection.  $R_{5A}$  and  $R_{5B}$  help prevent high frequency oscillations with the external N-channel MOSFET and related board parasitics.

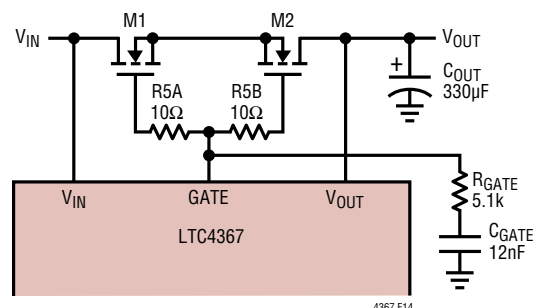

Figure 14. Limiting Inrush Current with  $C_{\text{GATE}}$

## APPLICATIONS INFORMATION

### Transients During OV Fault

The circuit of Figure 15 is used to display transients during an overvoltage condition. The nominal input supply is 48V and it has an overvoltage threshold of 60V. The parasitic inductance is that of a 1 foot wire (roughly 300nH). Figure 16 shows the waveforms during an overvoltage condition at  $V_{IN}$ . These transients depend on the parasitic inductance and resistance of the wire along with the ca-

pacitance at the  $V_{IN}$  node. D1 is an optional power clamp (TVS, TransZorb) recommended for applications where  $V_{IN}$  can ring above 100V. No clamp was used to capture the waveforms of Figure 16. In order to maintain reverse supply protection, D1 must be a bidirectional clamp rated for at least 225W peak pulse power dissipation.

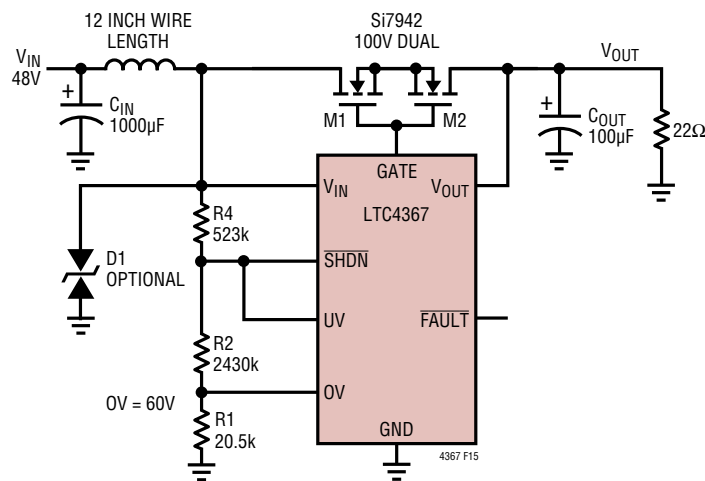

Figure 15. OV Fault with Large  $V_{IN}$  Inductance

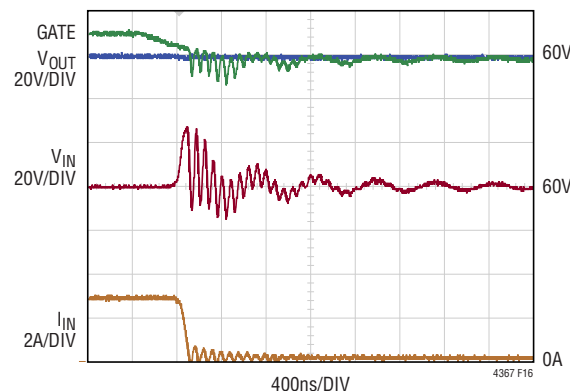

Figure 16. Transients During OV Fault When No TransZorb (TVS) Is Used

# APPLICATIONS INFORMATION

## REGULATOR APPLICATIONS

### Hysteretic Regulator

Built-in hysteresis and the availability of both inverting and noninverting control inputs (OV and UV) facilitate the design of hysteretic regulators. Figure 17 shows how the LTC4367-1 can protect a load from OV transients, while regulating the output voltage at a user-defined level. When the output voltage reaches its OV limit, the LTC4367-1 turns off the external MOSFETs. The load current then discharges the output capacitance until OV falls below the hysteresis voltage. The external MOSFETs are turned back on after a 500 $\mu$ s delay. Figure 18 shows the waveforms for the circuit of Figure 17. The voltage spikes on  $V_{IN}$  result

from the parasitic inductance of the  $V_{IN}$  connector. See Transient During 0V Fault section for more details.

### Solar Charger

Figure 19 shows a series regulator for a solar charger. The LTC4367-1 connects the solar charger to the battery when the battery voltage falls below 13.9V (after a 500 $\mu$ s delay). Conversely, when the battery reaches 14.6V, the LTC4367-1 immediately (2 $\mu$ s) opens the charging path.

Regulation of the battery voltage is achieved by connecting a resistive divider from the battery to the accurate OV comparator input (with 5% hysteresis). The fast rising response of the OV comparator prevents the battery voltage from rising above the user-selected threshold.

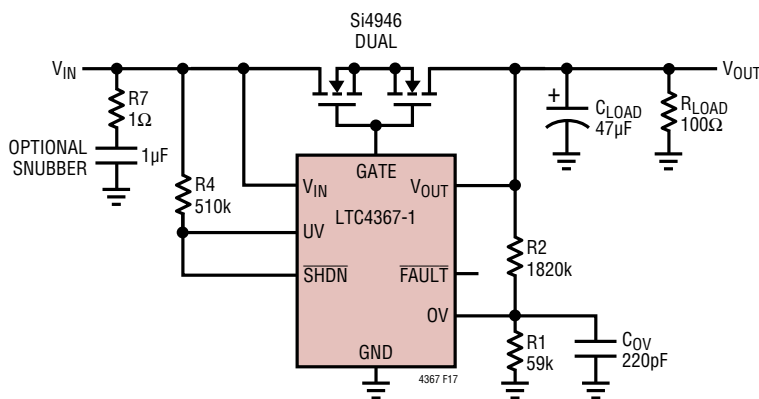

Figure 17. Hysteretic Regulation of  $V_{OUT}$  During OV Transients

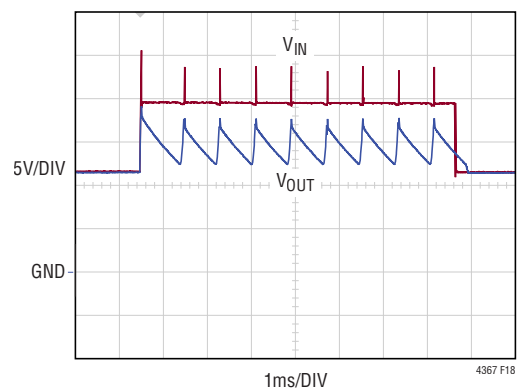

Figure 18.  $V_{OUT}$  Regulates at 16V When  $V_{IN}$  Rises Above Desired Level

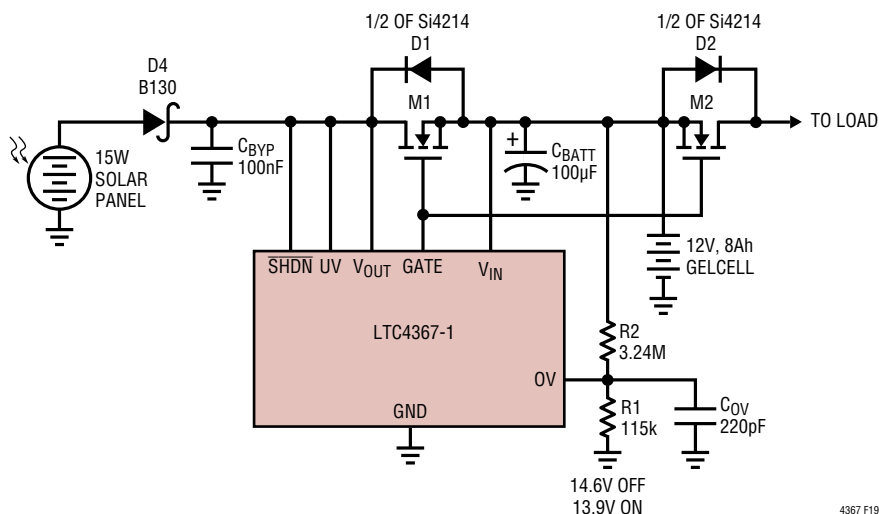

Figure 19. Series Hysteretic Solar Charger with Reverse-Battery and Solar Panel Protection

## APPLICATIONS INFORMATION

Note that during initial start-up, the LTC4367-1 will not turn on the external MOSFETs until a battery is first connected to the  $V_{IN}$  pin. To begin operation,  $V_{IN}$  must initially rise above the 2.2V UVLO lockout voltage. Connecting the battery ensures that the LTC4367-1 comes out of UVLO.

### 12V Application with 150V Transient Protection

Figure 20 shows a 12V application that withstands input supply transients up to 150V. When the input voltage exceeds 17.9V, the OV resistive divider turns off the external MOSFETs. As  $V_{IN}$  rises to 150V, the gate of transistor M1 remains in the Off condition, thus preventing conduction from  $V_{IN}$  to  $V_{OUT}$ . Note that M1 must have an operating range above 150V.

Resistor R6 and diode D3 clamp the LTC4367 supply voltage to 50V. To prevent R6 from interfering with reverse operation, the recommended value is 1k or less. Note that the power handling capability of R6 must be considered in order to avoid overheating during transients. D3 is shown as a bidirectional clamp in order to achieve reverse-polarity protection at  $V_{IN}$ . M2 is also required in order to protect  $V_{OUT}$  from negative voltages at  $V_{IN}$  and should have an operating range beyond the breakdown of D3. If reverse protection is not desired remove M2 and connect the source of M1 directly to  $V_{OUT}$ .

### MOSFET Selection

To protect against a negative voltage at  $V_{IN}$ , the external N-channel MOSFETs must be configured in a back-to-back arrangement. Dual N-channel packages are thus the best choice. The MOSFET is selected based on its power

handling capability, drain and gate breakdown voltages, and threshold voltage.

The drain to source breakdown voltage must be higher than the maximum voltage expected between  $V_{IN}$  and  $V_{OUT}$ . Note that if an application generates high energy transients during normal operation or during hot swap, the external MOSFET must be able to withstand this transient voltage.

Due to the high impedance nature of the charge pump that drives the GATE pin, the total leakage on the GATE pin must be kept low. The gate drive curves of Figure 3 were measured with a  $1\mu\text{A}$  load on the GATE pin. Therefore, the leakage on the GATE pin must be no greater than  $1\mu\text{A}$  in order to match the curves of Figure 3. Higher leakage currents will result in lower gate drive. The dual N-channel MOSFETs shown in Table 1 all have a maximum gate leakage current of 100nA. Additionally, Table 1 lists representative MOSFETs that would work at different values of  $V_{IN}$ .

### Layout Considerations

The trace length between the  $V_{IN}$  pin and the drain of the external MOSFET should be minimized, as well as the trace length between the GATE pin of the LTC4367 and the gates of the external MOSFETs.

Place the bypass capacitors at  $V_{OUT}$  as close as possible to the external MOSFET. Use high frequency ceramic capacitors in addition to bulk capacitors to mitigate hot swap ringing. Place the high frequency capacitors closest to the MOSFET. Note that bulk capacitors mitigate ringing by virtue of their ESR. Ceramic capacitors have low ESR and can thus ring near their resonant frequency.

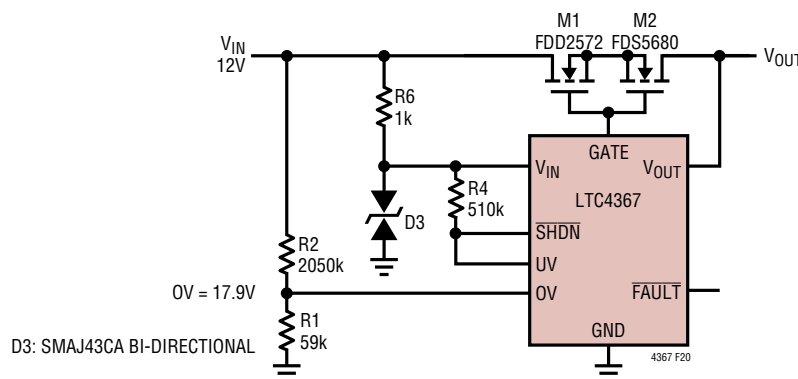

Figure 20. 12V Application Protected from 150V Transients

## PACKAGE DESCRIPTION

Please refer to <http://www.linear.com/product/LTC4367#packaging> for the most recent package drawings.

### MS8 Package 8-Lead Plastic MSOP

(Reference LTC DWG # 05-08-1660 Rev G)

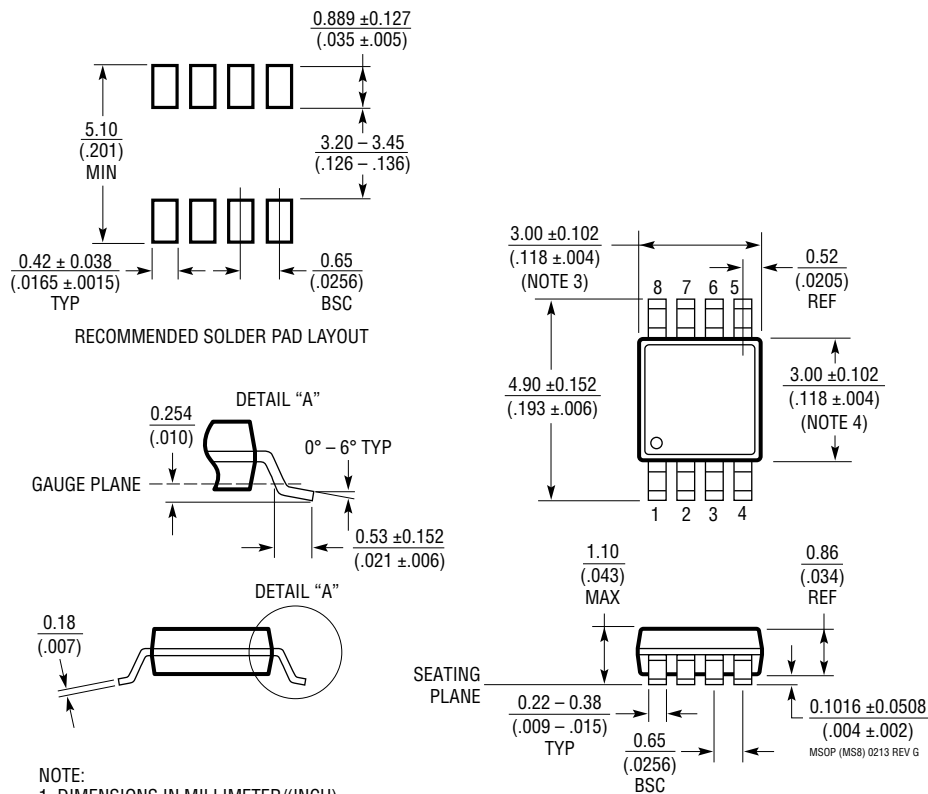

#### NOTE:

1. DIMENSIONS IN MILLIMETER/(INCH)
2. DRAWING NOT TO SCALE
3. DIMENSION DOES NOT INCLUDE MOLD FLASH, PROTRUSIONS OR GATE BURRS.  
MOLD FLASH, PROTRUSIONS OR GATE BURRS SHALL NOT EXCEED  $0.152\text{mm}$  ( $.006$ ) PER SIDE
4. DIMENSION DOES NOT INCLUDE INTERLEAD FLASH OR PROTRUSIONS.  
INTERLEAD FLASH OR PROTRUSIONS SHALL NOT EXCEED  $0.152\text{mm}$  ( $.006$ ) PER SIDE
5. LEAD COPLANARITY (BOTTOM OF LEADS AFTER FORMING) SHALL BE  $0.102\text{mm}$  ( $.004$ ) MAX

# PACKAGE DESCRIPTION

Please refer to <http://www.linear.com/product/LTC4367#packaging> for the most recent package drawings.

**DD Package**  
**8-Lead Plastic DFN (3mm × 3mm)**  
 (Reference LTC DWG # 05-08-1698 Rev C)

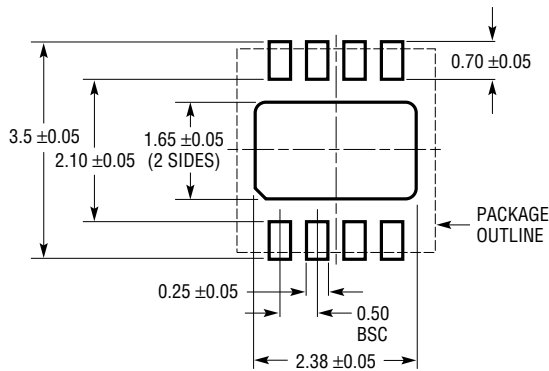

RECOMMENDED SOLDER PAD PITCH AND DIMENSIONS  
 APPLY SOLDER MASK TO AREAS THAT ARE NOT SOLDERED

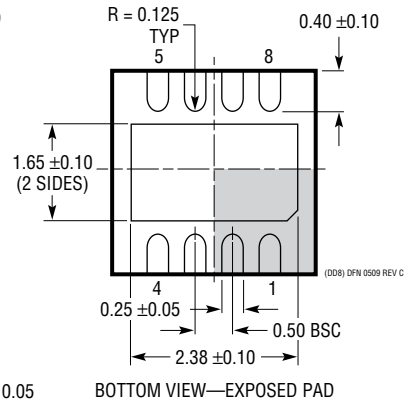
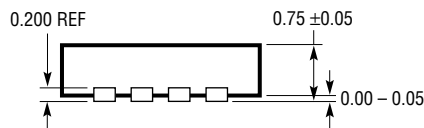
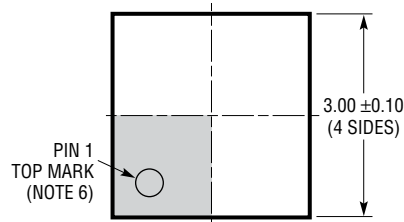

- NOTE:
1. DRAWING TO BE MADE A JEDEC PACKAGE OUTLINE M0-229 VARIATION OF (WEED-1)
  2. DRAWING NOT TO SCALE
  3. ALL DIMENSIONS ARE IN MILLIMETERS
  4. DIMENSIONS OF EXPOSED PAD ON BOTTOM OF PACKAGE DO NOT INCLUDE MOLD FLASH. MOLD FLASH, IF PRESENT, SHALL NOT EXCEED 0.15mm ON ANY SIDE
  5. EXPOSED PAD SHALL BE SOLDER PLATED
  6. SHADED AREA IS ONLY A REFERENCE FOR PIN 1 LOCATION ON TOP AND BOTTOM OF PACKAGE

## REVISION HISTORY

REV	DATE	DESCRIPTION	PAGE NUMBER
A	03/16	Updated Typical Application and Figures 1, 2, 13, 15	1, 9, 10, 15, 16
		Updated $\overline{\text{SHDN}}$ , UV input current rating	2
		Changed $I_{\text{SHDN}}$ test condition to 10V from 0.75V	4
		Updated graphs G09 and G12	5, 6
		Updated $\overline{\text{SHDN}}$ and UV Pin Functions	7
B	10/17	Increased $t_{\text{GATE(SLOW)}}$ max limit to 575 $\mu\text{s}$	3
		Increased $t_{\text{GATE(FAST)}}$ max limit to 6 $\mu\text{s}$	3
		Increased $t_{\text{START}}$ max limit to 1400 $\mu\text{s}$	4

## TYPICAL APPLICATION

LTC4367 Protects Step Down Regulator from -30V to 30V  $V_{IN}$  Faults

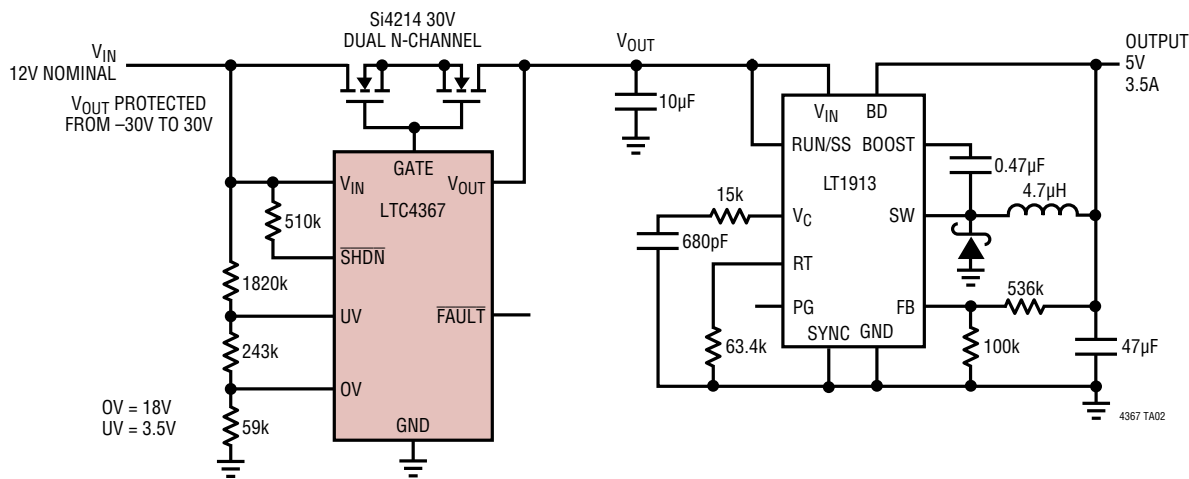

## RELATED PARTS

PART NUMBER	DESCRIPTION	COMMENTS
<a href="#">LTC4365</a>	Overvoltage, Undervoltage and Reverse Supply Protection Controller	Wide Operating Range: 2.5V to 34V, Protection Range: -40V to 60V, No TVS Required for Most Applications
<a href="#">LTC4368</a>	LTC4367 + Bidirectional Circuit Breaker	±50mV or 50mV/-3mV Circuit Breaker Thresholds; MSOP-10, DFN-10 Packages
<a href="#">LTC4380</a>	8µA Quiescent Current Surge Stopper	4V to 72V Operation; -60V Input Protection; Pin-Selectable Clamp
<a href="#">LT4363</a>	Surge Stopper Overvoltage/Overcurrent Protection Regulator	Wide Operating Range: 4V to 80V, Reverse Protection to -60V, Adjustable Output Clamp Voltage
<a href="#">LTC4364</a>	Surge Stopper with Ideal Diode	4V to 80V Operation, -40V Reverse Input, -20V Reverse Output
<a href="#">LTC4366</a>	Floating Surge Stopper	9V to >500V Operation, 8-Pin TSOT and 3mm × 2mm DFN Packages
<a href="#">LTC4361</a>	Overvoltage/Overcurrent Protection Controllers	5.8V Overvoltage Threshold, 85V Absolute Maximum
<a href="#">LTC2909</a>	Triple/Dual Inputs UV/OV Negative Monitor	Pin Selectable Input Polarity Allows Negative and OV Monitoring
<a href="#">LTC2912/LTC2913</a>	Single/Dual UV/OV Voltage Monitor	Adjustable UV and OV Trip Values, ±1.5% Threshold Accuracy
<a href="#">LTC2914</a>	Quad UV/OV Monitor	For Positive and Negative Supplies
<a href="#">LTC2955</a>	Pushbutton On/Off Controller	Automatic Turn-On, 1.5V to 36V Input, ±36V PB Input
<a href="#">LT4256</a>	Positive 48V Hot Swap Controller with Open-Circuit Detect	Foldback Current Limiting, Open-Circuit and Overcurrent Fault Output, Up to 80V Supply
<a href="#">LTC4260</a>	Positive High Voltage Hot Swap Controller with ADC and I <sup>2</sup> C	Wide Operating Range 8.5V to 80V
<a href="#">LTC4352</a>	Ideal MOSFET ORing Diode	External N-Channel MOSFETs Replace ORing Diodes, 0V to 18V
<a href="#">LTC4354</a>	Negative Voltage Diode-OR Controller	Controls Two N-Channel MOSFETs, 1.2µs Turn-Off, -80V Operation
<a href="#">LTC4355</a>	Positive Voltage Diode-OR Controller	Controls Two N-Channel MOSFETs, 0.4µs Turn-Off, 80V Operation
<a href="#">LT1913</a>	Step-Down Switching Regulator	3.6V to 25V Input, 3.5A Maximum Current, 200kHz to 2.4MHz

## Looking for pricing, stock, or lifecycle information?

Click below to explore more details on WIN SOURCE:

- ⊖ [View LTC4367HMS8-1#TRPBF on WIN SOURCE](#)
- ⊖ [Analog Devices Inc. Information](#)

## Optimize Your Supply Chain with WIN SOURCE Solutions

- ✓ Global Sourcing Solution
- ✓ Obsolete Management
- ✓ Cost Control Management
- ✓ Shortage Management
- ✓ Alternative Solution
- ✓ Excess Inventory Management