



**THE DATASHEET OF  
LTC4091EDJC#PBF**



## 36V Battery Charger and Power Backup Manager

### FEATURES

- Seamless Transition Between Primary Power Source and Li-Ion Battery
- 2A High Voltage Step-Down Regulator with Adaptive Output Control
- Internal 75mΩ Ideal Diode Plus Optional External Ideal Diode Controller Provides Low Loss PowerPath™ When Primary Supply Not Present
- Wide Input Voltage Range: 6V to 36V (60V Abs Max)
- 4.45V Max Output Voltage
- Full Featured Li-Ion Battery Charger
- Pin Selectable 4.1V and 4.2V Charge Voltage Options
- Thermally Enhanced Low Profile (0.75mm) 6mm × 3mm 22-Lead DFN Package

### APPLICATIONS

- Fleet and Asset Tracking
- Automotive GPS Data Loggers
- Automotive Telematics Systems
- Battery Backup Systems

### DESCRIPTION

The LTC4091 is a 36V Li-Ion battery charger and power backup manager. The integrated step-down switching regulator charges a battery from a primary power source while providing power to the load. If primary power is lost, the load is seamlessly transitioned to the backup Li-ion/polymer battery. To protect sensitive downstream loads, the maximum output voltage is 4.45V.

The LTC4091 provides an adaptive output that tracks the battery voltage for high efficiency charging. The charge current is programmable and an end-of-charge status output (CHRG) indicates full charge. Also featured is a termination timer and an NTC thermistor input used to monitor battery temperature while charging.

During backup, an internal 75mΩ ideal diode connects the battery to the load. An optional external ideal diode FET driver is available to reduce the voltage drop even further. 4.1V or 4.2V battery charge voltages can be selected.

LT, LTC, LTM, Linear Technology, the Linear logo and Burst Mode are registered trademarks and PowerPath and Bat-Track are trademarks of Analog Devices, Inc. All other trademarks are the property of their respective owners.

### TYPICAL APPLICATION

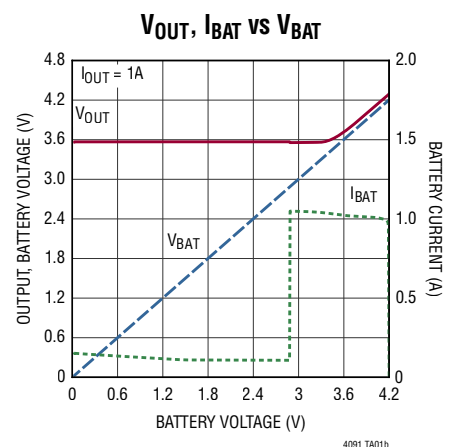
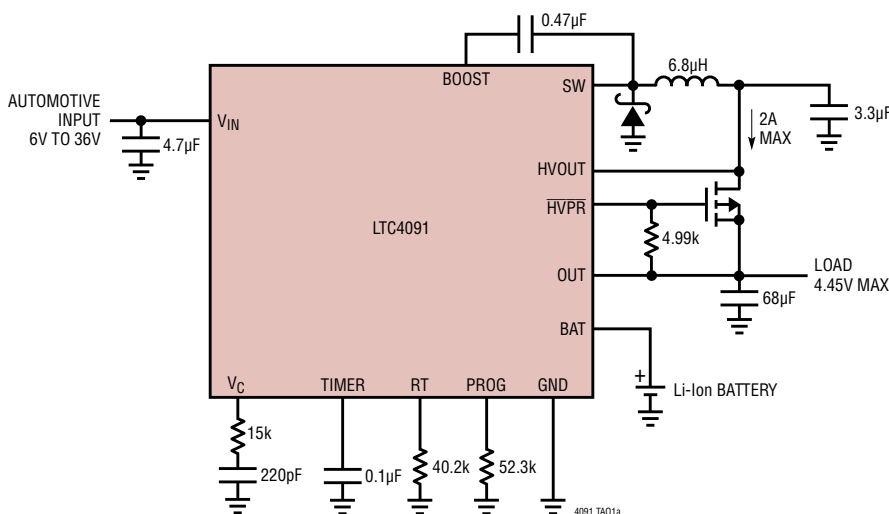

# LTC4091

## ABSOLUTE MAXIMUM RATINGS

(Notes 1, 2, 3, 4)

$V_{IN}$ , RUN/SS (Note 7)	60V
BOOST	56V
BOOST Above SW	30V
$\overline{VINGD}$ , SYNC	30V
OUT, HVOUT	
$t < 1\text{ms}$ and Duty Cycle $< 1\%$	-0.3V to 7V
Steady State	-0.3V to 6V
BAT, V4P1, $V_C$ , CHRG, HVPR	-0.3V to 6V
NTC, TIMER, PROG	-0.3V to $V_{CC} + 0.3\text{V}$
$I_{OUT}$ , $I_{BAT}$	4A
Operating Junction Temperature	
Range	-40°C to 125°C
Storage Temperature Range	-65 to 150°C

## PIN CONFIGURATION

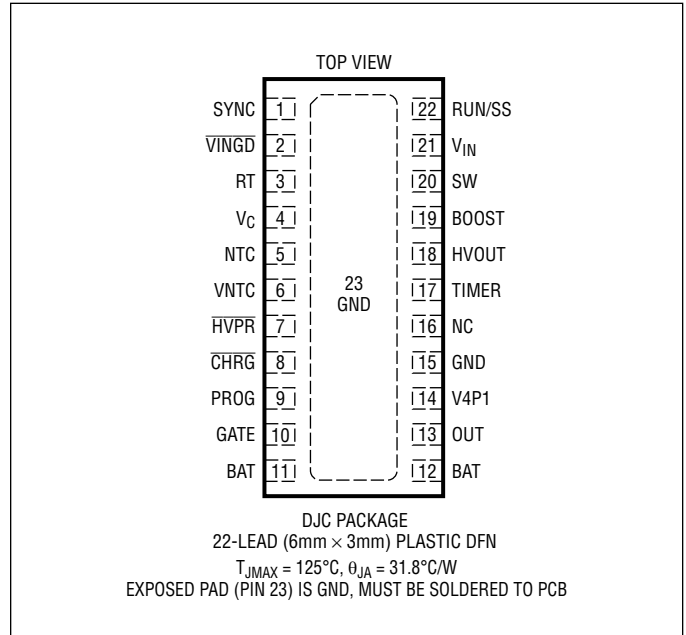

## ORDER INFORMATION

<http://www.linear.com/product/LTC4091#orderinfo>

LEAD FREE FINISH	TAPE AND REEL	PART MARKING*	PACKAGE DESCRIPTION	TEMPERATURE RANGE
LTC4091EDJC#PBF	LTC4091EDJC#TRPBF	4091	22-Lead (6mm × 3mm) Plastic DFN	-40°C to 125°C
LTC4091IDJC#PBF	LTC4091IDJC#TRPBF	4091	22-Lead (6mm × 3mm) Plastic DFN	-40°C to 125°C

Consult LTC Marketing for parts specified with wider operating temperature ranges. \*The temperature grade is identified by a label on the shipping container.

For more information on lead free part marking, go to: <http://www.linear.com/leadfree/>

For more information on tape and reel specifications, go to: <http://www.linear.com/tapeandreeel/>. Some packages are available in 500 unit reels through designated sales channels with #TRMPBF suffix.

**ELECTRICAL CHARACTERISTICS** The ● denotes the specifications which apply over the specified operating junction temperature range, otherwise specifications are at  $T_A = 25^\circ\text{C}$ . (Note 2)  $V_{\text{IN}} = \text{RUN/SS} = 12\text{V}$ ,  $\text{BOOST} = 17\text{V}$ ,  $V_{\text{BAT}} = 3.7\text{V}$  and  $R_{\text{PROG}} = 105\text{k}$ , unless otherwise noted.

SYMBOL	PARAMETER	CONDITIONS	MIN	TYP	MAX	UNITS	
<b>Switching Step-Down Regulator</b>							
$V_{\text{VIN}}$	Operating Supply Voltage		●	6	36	V	
$V_{\text{OVLO}}$	$V_{\text{IN}}$ Overvoltage Lockout Threshold		●	36	38	40	V
$I_{\text{VIN}}$	$V_{\text{IN}}$ Bias Current	Shutdown; RUN/SS = 0.2V Charger Terminated, $R_{\text{HVPR}} = 4.99\text{k}$		0.01 1.1	1	$\mu\text{A}$ mA	
$V_{\text{OUT}}$	Output Voltage with $V_{\text{IN}}$ Present	Assumes HVOUT to OUT Connection		3.45	$V_{\text{BAT}}+0.1$	4.45	V
$f_{\text{SW}}$	Switching Frequency	$R_T = 8.66\text{k}$ $R_T = 29.4\text{k}$ $R_T = 187\text{k}$		2.1 900 160	2.4 1000 200	2.7 1150 240	MHz kHz kHz
$t_{\text{OFF}}$	Minimum Switch Off-Time		●	60	150	ns	
$I_{\text{SW(MAX)}}$	Switch Current Limit			2.5	3.8	5.0	A
$V_{\text{SAT}}$	Switch $V_{\text{CESAT}}$	$I_{\text{SW}} = 2\text{A}$			500	mV	
$I_{\text{R}}$	Boost Schottky Reverse Leakage	$\text{SW} = 10\text{V}$ , $\text{HVOUT} = 0\text{V}$			0.02	2	$\mu\text{A}$
$V_{\text{B(MIN)}}$	Minimum Boost Voltage (Note 6)		●		1.5	2.1	V
$I_{\text{BST}}$	BOOST Pin Current	$I_{\text{SW}} = 1\text{A}$			22	35	mA
<b>Battery Management (Note 8)</b>							
$I_{\text{BAT}}$	Battery Drain Current	$V_{\text{VIN}} = 0\text{V}$ , BAT Powers OUT, No Load	●		60	100	$\mu\text{A}$
$V_{\text{CHG}}$	$V_{\text{BAT}}$ Regulated Output Voltage	$I_{\text{BAT}} = 2\text{mA}$ ; V4P1 = Open $I_{\text{BAT}} = 2\text{mA}$ ; V4P1 = BAT		4.148 4.048	4.200 4.100	4.252 4.152	V V
$I_{\text{CHG}}$	Constant-Current Mode Charge Current	$R_{\text{PROG}} = 105\text{k}$ , No Load $R_{\text{PROG}} = 52.3\text{k}$ , No Load; $0 \leq T_A \leq 85^\circ\text{C}$	● ●	465 880	500 1000	550 1100	mA mA
$I_{\text{CHG(MAX)}}$	Maximum Charge Current	(Note 5)			1.5		A
$V_{\text{PROG}}$	PROG Pin Servo Voltage	$R_{\text{PROG}} = 105\text{k}$ $R_{\text{PROG}} = 52.3\text{k}$	● ●	0.98 0.98	1.00 1.00	1.02 1.02	V V
$k_{\text{EOC}}$	Ratio of End-of-Charge Indication Current to Charge Current	$V_{\text{BAT}} = V_{\text{CHG}} (4.2\text{V})$	●	0.08	0.1	0.13	mA/mA
$I_{\text{TRKL}}$	Trickle Charge Current	BAT = 2V		35	50	75	mA
$V_{\text{TRKL}}$	Trickle Charge Threshold Voltage	BAT Rising	●	2.75	2.9	3.0	V
$V_{\text{CEN}}$	Charger Enable Threshold Voltage	$(V_{\text{OUT}} - V_{\text{BAT}})$ Falling; $V_{\text{BAT}} = 4\text{V}$ $(V_{\text{OUT}} - V_{\text{BAT}})$ Rising; $V_{\text{BAT}} = 4\text{V}$			55 80		mV mV
$\Delta V_{\text{RECHRG}}$	Recharge Battery Threshold Voltage	Threshold Voltage Relative to $V_{\text{CHG}}$	●	-65	-100	-150	mV
$t_{\text{TIMER}}$	TIMER Accuracy	$V_{\text{BAT}} = 4.3\text{V}$		-10		10	%
	Recharge Time	Percent of Total Charge Time			50		%
	Low Battery Trickle Charge Time	Percent of Total Charge Time, $V_{\text{BAT}} < V_{\text{TRKL}}$			25		%
$T_{\text{LIM}}$	Junction Temperature in Constant Temperature Mode				105		$^\circ\text{C}$
<b>Internal Ideal Diode</b>							
$R_{\text{DIO,ON}}$	On Resistance $V_{\text{BAT}}$ to $V_{\text{OUT}}$	$I_{\text{OUT}} = 2\text{A}$			75		$\text{m}\Omega$
$V_{\text{FWD}}$	Voltage Forward Drop ( $V_{\text{BAT}} - V_{\text{OUT}}$ )	$I_{\text{OUT}} = 5\text{mA}$ $I_{\text{OUT}} = 100\text{mA}$ $I_{\text{OUT}} = 1000\text{mA}$	●	10	30 40 75	50	mV mV mV

## ELECTRICAL CHARACTERISTICS

The ● denotes the specifications which apply over the specified operating junction temperature range, otherwise specifications are at  $T_A = 25^\circ\text{C}$ . (Note 2)  $V_{IN} = \text{RUN/SS} = 12\text{V}$ ,  $\text{BOOST} = 17\text{V}$ ,  $V_{BAT} = 3.7\text{V}$  and  $R_{\text{PROG}} = 105\text{k}$ , unless otherwise noted.

SYMBOL	PARAMETER	CONDITIONS	MIN	TYP	MAX	UNITS	
<b>External Ideal Diode</b>							
$V_{\text{FWD,EXT}}$	External Diode Forward Voltage			20		mV	
<b>Logic (CHRG, VINGD, HVPR, TIMER, RUN/SS, SYNC)</b>							
$V_{\text{CHG,SD}}$	Charger Shutdown Threshold Voltage on TIMER	$V_{\text{TIMER}}$ Falling	●		0.1	V	
$I_{\text{CHG,SD}}$	Charger Shutdown Pull-Up Current on TIMER	$V_{\text{TIMER}} = 0\text{V}$	●	5	14	$\mu\text{A}$	
$V_{\text{OL}}$	Output Low Voltage	(CHRG, HVPR); $I_{\text{SINK}} = 5\text{mA}$	●		0.1	0.4	V
$V_{\text{RUN,H}}$	RUN/SS High Threshold			3		V	
$V_{\text{RUN,L}}$	RUN/SS Low Threshold				0.2	V	
$I_{\text{RUN/SS}}$	RUN/SS Pin Bias Current	RUN/SS = 2.5V			5	10	$\mu\text{A}$
$I_{\text{VGLK}}$	VINGD Leakage	VINGD = 5V, RUN/SS = 0V			0.1	1	$\mu\text{A}$
$I_{\text{VG}}$	VINGD Sink Current	VINGD = 0.4V	●	100	400	$\mu\text{A}$	
$V_{\text{SYNC,L}}$	SYNC Low Threshold				0.3	V	
$V_{\text{SYNC,H}}$	SYNC High Threshold			1		V	
$I_{\text{SYNC}}$	SYNC Pin Bias Current	$V_{\text{SYNC}} = 0\text{V}$			-0.1	$\mu\text{A}$	
<b>NTC</b>							
$I_{\text{VNTC}}$	VNTC Pin Current	VNTC = 2.5V		1.4	2.5	3.5	mA
$V_{\text{VNTC}}$	VNTC Bias Voltage	$I_{\text{VNTC}} = 500\mu\text{A}$	●	4.4	4.85		V
$I_{\text{NTC}}$	NTC Input Leakage Current	NTC = 1V			0	$\pm 1$	$\mu\text{A}$
$V_{\text{COLD}}$	Cold Temperature Fault Threshold Voltage	Rising NTC Voltage Hysteresis			$0.738 \cdot \text{VNTC}$ $0.02 \cdot \text{VNTC}$		V V
$V_{\text{HOT}}$	Hot Temperature Fault Threshold Voltage	Falling NTC Voltage Hysteresis			$0.290 \cdot \text{VNTC}$ $0.01 \cdot \text{VNTC}$		V V
$V_{\text{DIS}}$	NTC Disable Threshold Voltage	Falling NTC Voltage Hysteresis	●	75	100 35	125	mV mV

**Note 1:** Stresses beyond those listed under Absolute Maximum Ratings may cause permanent damage to the device. Exposure to any Absolute Maximum Rating condition for extended periods may affect device reliability and lifetime.

**Note 2:** The LTC4091 is tested under pulsed load conditions such that  $T_J \approx T_A$ . The LTC4091E is guaranteed to meet specifications from  $0^\circ\text{C}$  to  $85^\circ\text{C}$  junction temperature. Specifications over the  $-40^\circ\text{C}$  to  $125^\circ\text{C}$  operating junction temperature range are assured by design, characterization and correlation with statistical process controls. The LTC4091 is guaranteed over the  $-40^\circ\text{C}$  to  $125^\circ\text{C}$  operating junction temperature range. Note that the maximum ambient temperature consistent with these specifications is determined by specific operating conditions in conjunction with board layout, the rated package thermal impedance and other environmental factors. The junction temperature ( $T_J$ , in  $^\circ\text{C}$ ) is calculated from the ambient temperature ( $T_A$ , in  $^\circ\text{C}$ ) and power dissipation ( $P_D$ , in Watts) according to the formula:

$$T_J = T_A + (P_D \cdot \theta_{JA})$$

where  $\theta_{JA} = 31.8^\circ\text{C/W}$  for the DJC package.

**Note 3:** This IC includes overtemperature protection that is intended to protect the device during momentary overload conditions. Junction temperatures will exceed  $110^\circ\text{C}$  when overtemperature protection is active. Continuous operation above the specified maximum operating junction temperature may result in device degradation or failure.

**Note 4:**  $V_{CC}$  is the greater of  $V_{OUT}$ , and  $V_{BAT}$

**Note 5:** Accuracy of programmed current may degrade for currents greater than 1.5A.

**Note 6:** This is the minimum voltage across the boost capacitor needed to guarantee full saturation of the switch.

**Note 7:** Absolute Maximum Voltage at  $V_{IN}$  and RUN/SS pins is for nonrepetitive one second transients; 40V for continuous operation.

**Note 8:** Due to the thermal regulation feature of the battery charger, circuit parameters in the Battery Management section are not testable and do not apply above  $85^\circ\text{C}$ .

**TYPICAL PERFORMANCE CHARACTERISTICS**  $T_A = 25^\circ\text{C}$ , unless otherwise noted.

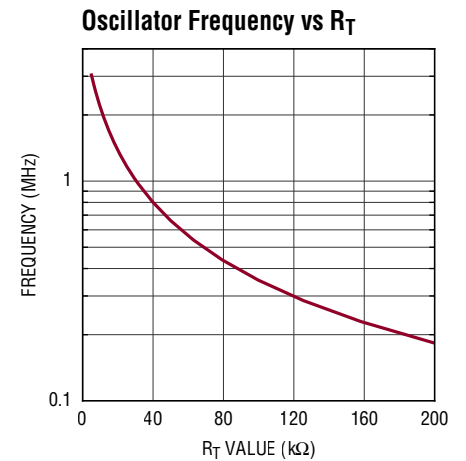
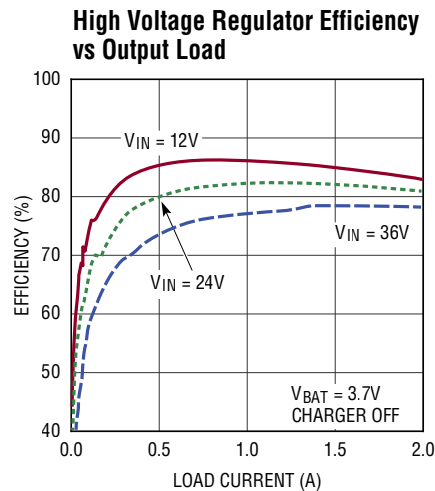
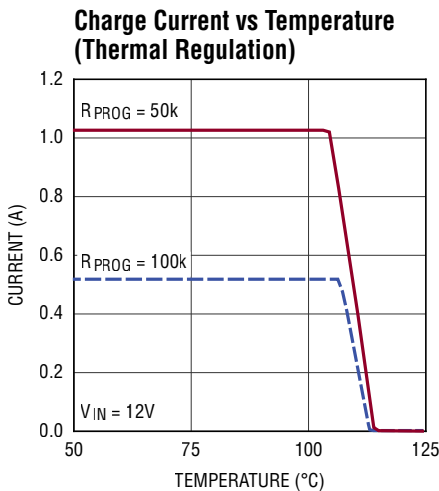
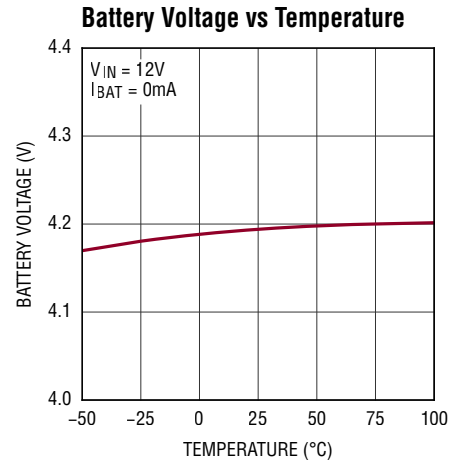
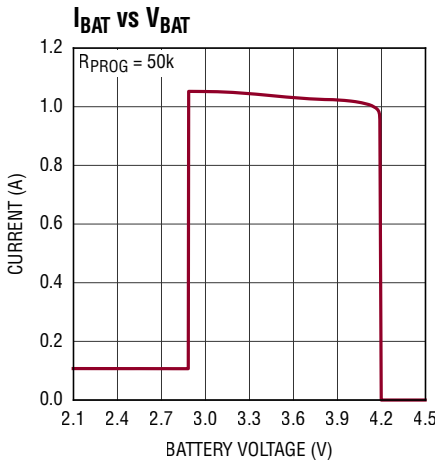
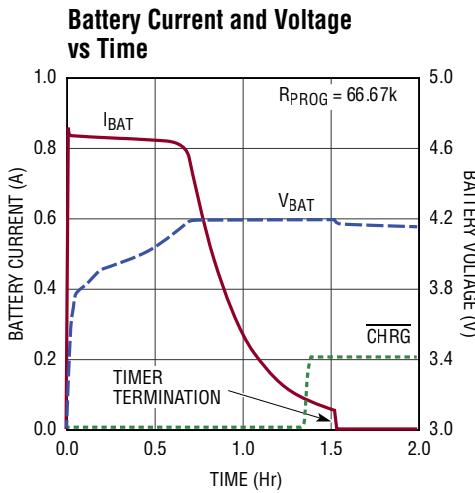
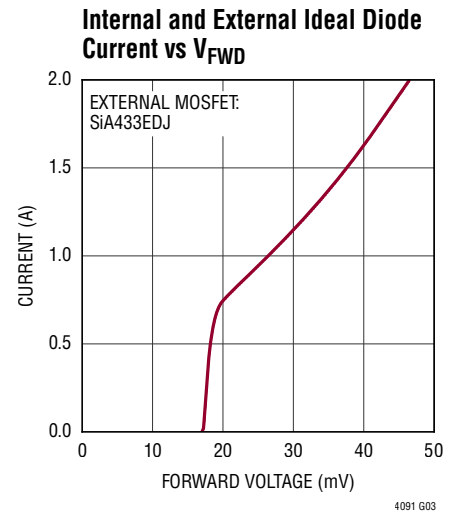
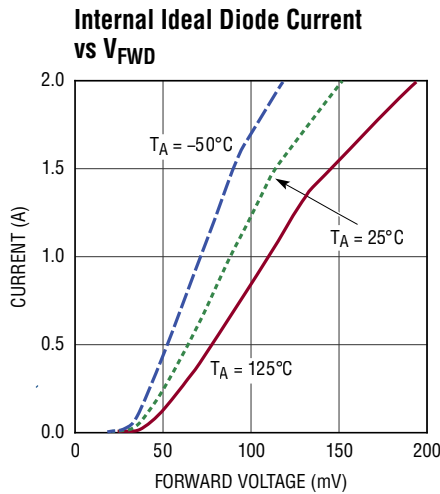
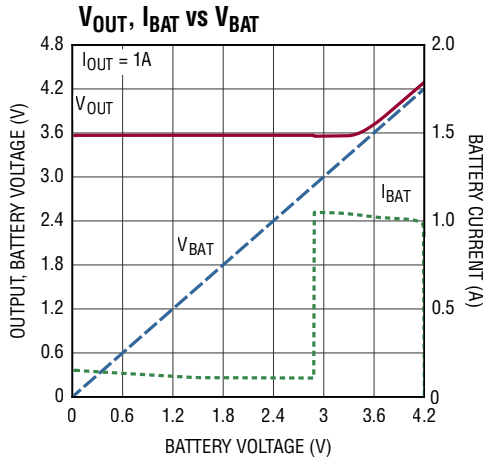

## TYPICAL PERFORMANCE CHARACTERISTICS $T_A = 25^\circ\text{C}$ , unless otherwise noted.

### Switch Current Limit

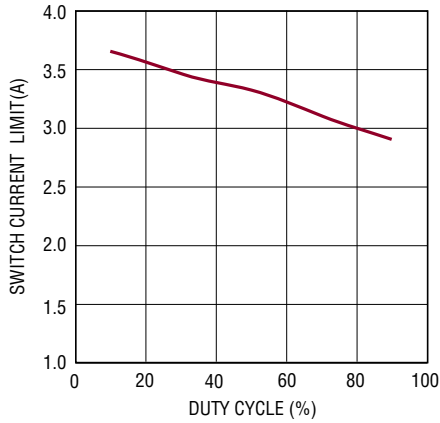

4091 G10

### Switch Current Limit

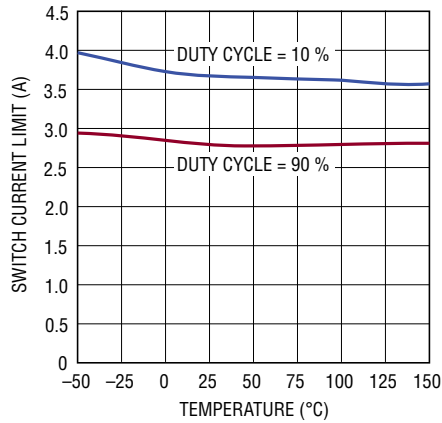

4091 G11

### Soft-Start

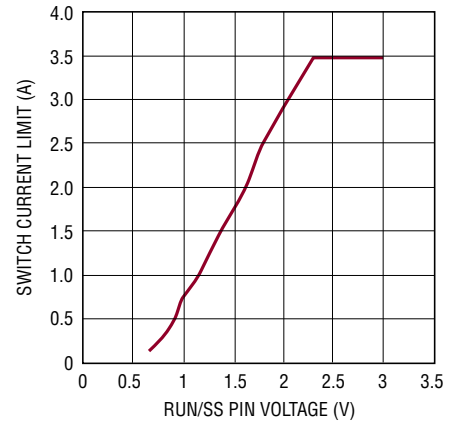

4091 G12

### Minimum Switch On-Time

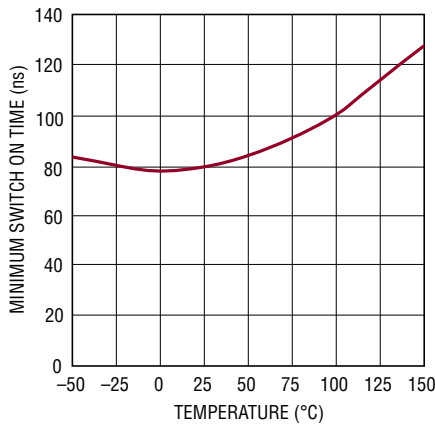

4091 G13

### Switching Frequency

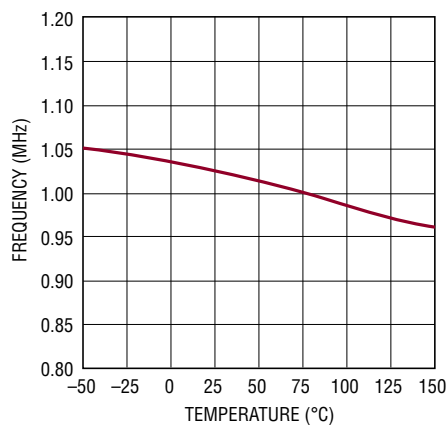

4091 G14

### Switch Voltage Drop

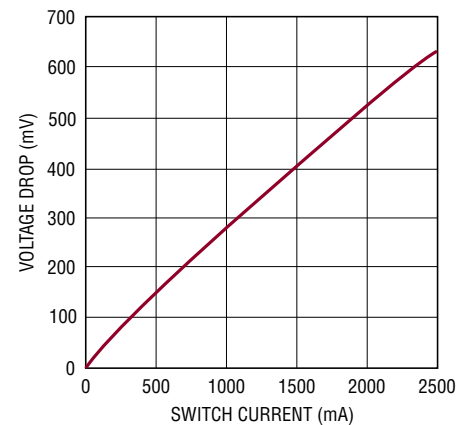

4091 G15

### OUT During $V_{IN}$ Hot-Plug

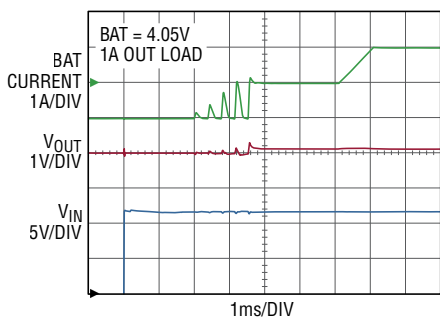

4091 G16

### OUT During $V_{IN}$ Cold Crank

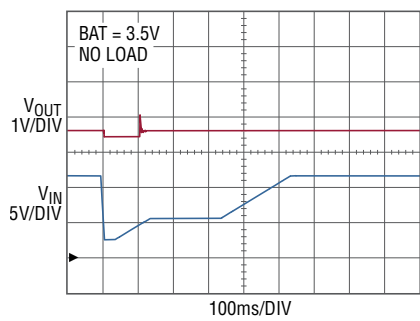

4091 G17

### Histogram of $V_{CHG}$

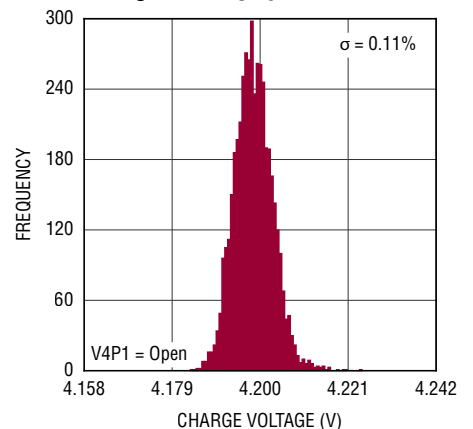

4091 G18

## PIN FUNCTIONS

**SYNC (Pin 1):** External Clock Synchronization Input. See synchronizing section in Applications Information. Ground pin when not used.

**VINGD (Pin 2):** The  $\overline{\text{VINGD}}$  pin is the open collector output of an internal comparator.  $\overline{\text{VINGD}}$  remains high impedance until sufficient voltage is present on  $V_{\text{IN}}$  to enable the switching regulator and RUN/SS is high.

**RT (Pin 3):** Oscillator Resistor Input. Connecting a resistor to ground from this pin sets the switching frequency.

**V<sub>C</sub> (Pin 4):** High Voltage Buck Regulator Control Pin. The voltage on this pin controls the peak switch current in the high voltage regulator. Tie an RC network from this pin to ground to compensate the control loop.

**NTC (Pin 5):** Input to the NTC Thermistor Monitoring Circuits. The NTC pin connects to a negative temperature coefficient thermistor which is typically co-packaged with the battery pack to determine if the battery is too hot or too cold to charge. If the battery temperature is out of range, charging is paused until the battery temperature re-enters the valid range. A low drift bias resistor is required from VNTC to NTC and a thermistor is required from NTC to ground. If the NTC function is not desired, the NTC pin should be grounded.

**VNTC (Pin 6):** Output Bias Voltage for NTC. A resistor from this pin to the NTC pin will bias the NTC thermistor.

**HVPR (Pin 7):** Open-Drain High Voltage Present Output (Active Low). A low on this pin indicates that the high voltage regulator has sufficient voltage to charge the battery.

**CHRG (Pin 8):** Open-Drain Charge Status Output. When the battery is being charged, the  $\overline{\text{CHRG}}$  pin is pulled low by an internal N-channel MOSFET. When the timer runs out or the charge current drops below 10% of the programmed charge current or the input supply is removed, the  $\overline{\text{CHRG}}$  pin is forced to a high impedance state.

**PROG (Pin 9):** Charge Current Program Pin. Connecting a resistor from PROG to ground programs the charge current:

$$I_{\text{CHG}}(\text{A}) = \frac{52,500\text{V}}{R_{\text{PROG}}}$$

**GATE (Pin 10):** External Ideal Diode Gate Connection. This pin controls the gate of an optional external P-channel MOSFET transistor used to supplement the internal ideal diode. The source of the P-channel MOSFET should be connected to OUT and the drain should be connected to BAT. When not in use, this pin should be left floating. It is important to maintain high impedance on this pin and minimize all leakage paths.

**BAT (Pins 11, 12):** Single-Cell Li-Ion Battery. This pin is used as an output when charging the battery and as an input when supplying power to OUT. When the OUT pin potential drops below the BAT pin potential, an ideal diode function connects BAT to OUT and prevents OUT from dropping more than 100mV below BAT. A precision internal resistor divider sets the final charge voltage on this pin.

**OUT (Pin 13):** Voltage Output. This pin is used to provide controlled power to a load from either the primary input ( $V_{\text{IN}}$ ) or the battery (BAT). OUT should be bypassed with at least 68 $\mu\text{F}$  to GND.

**V4P1 (Pin 14):** 4.1V Charge Voltage Select Pin. Leave this pin disconnected to select a 4.2V charge voltage. Connect this pin to the BAT pin to select a 4.1V charge voltage. Care should be taken to avoid leakage on the V4P1 pin if it is left open.

**GND (Pin 15):** Ground Pin.

**NC (Pin 16):** No Connect. Nothing is connected to this pin.

**TIMER (Pin 17):** Timer Capacitor. Placing a capacitor,  $C_{\text{TIMER}}$ , to GND sets the timer period. The timer period is:

$$t_{\text{TIMER}}(\text{hours}) = C_{\text{TIMER}}(\text{F}) \cdot R_{\text{PROG}}(\Omega) \cdot 300$$

## PIN FUNCTIONS

Charge time is increased if charge current is reduced due to thermal regulation.

Shorting the TIMER pin to GND disables the battery charging functions.

**HVOUT (Pin 18):** Voltage Output of the Switching Regulator. When sufficient voltage is present at HVOUT, the HVPR pin will be pulled low to indicate that the primary input has been detected. The LTC4091 switching regulator will maintain just enough differential voltage between HVOUT and BAT to keep the battery charger MOSFET out of dropout (typically 100mV from OUT to BAT). HVOUT should be bypassed with 3.3 $\mu$ F to GND.

**BOOST (Pin 19):** This pin is used to provide drive voltage, higher than the input voltage, to the internal bipolar NPN power switch. Place a 0.22 $\mu$ F to 1 $\mu$ F capacitor between BOOST and SW as close as possible to the IC. See Applications section for more information.

**SW (Pin 20):** The SW pin is the output of the internal high voltage power switch. Connect this pin to the inductor, catch diode and a boost capacitor.

**V<sub>IN</sub> (Pin 21):** Switching Regulator Input. The V<sub>IN</sub> pin supplies current to the internal high voltage regulator and to the internal high voltage power switch. This pin must be locally bypassed. See Applications Information section to determine value.

**RUN/SS (Pin 22):** High Voltage Regulator Enable Input. The RUN/SS pin is used to enable the high voltage regulator. Tie to ground to disable the high voltage input or tie to at least 3V to enable the high voltage path. If this feature is not used tie to the V<sub>IN</sub> pin. This pin can also be used to soft-start the high voltage regulator; see the Applications Information section for more information.

**GND (Exposed Pad Pin 23):** Ground. The exposed package pad is ground and must be soldered to the PC board for proper functionality and for maximum heat transfer (use several vias directly under the LTC4091).

# BLOCK DIAGRAM

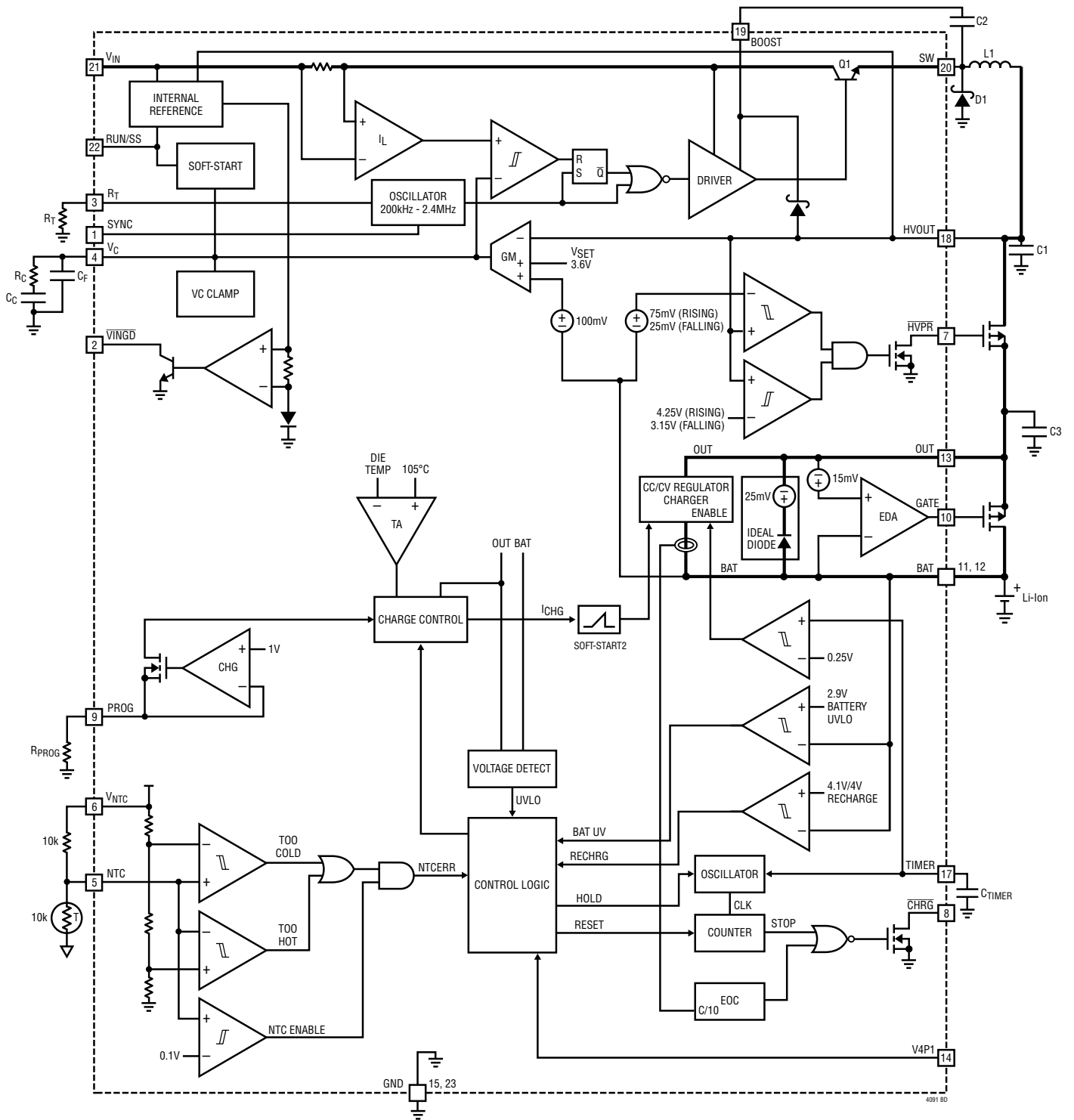

## OPERATION

### Introduction

The LTC4091 is a high voltage switching battery charger and power supply as well as a battery backup manager. The LTC4091 is designed to receive power from a primary input source (e.g. automotive battery, 12V wall adapter, etc.) and a single-cell Li-Ion battery. The switching regulator produces a voltage between 3.6V and 4.45V to charge the battery and power the system load. If the primary source fails and can no longer power the load, the LTC4091 seamlessly transitions to the backup battery (see Figure 1 for a simplified block diagram).

When enabled, the LTC4091 regulates the HVOUT voltage using a constant frequency, current mode regulator. An external PFET between HVOUT (drain) and OUT (source) is turned on via the HVPR pin allowing OUT to charge the battery and/or supply power to the application. The LTC4091 maintains approximately 100mV between the HVOUT pin and the BAT pin.

An ideal diode function provides power from the battery when input power is removed. Powering the load through the ideal diode instead of connecting the load directly to the battery allows a fully charged battery to remain fully

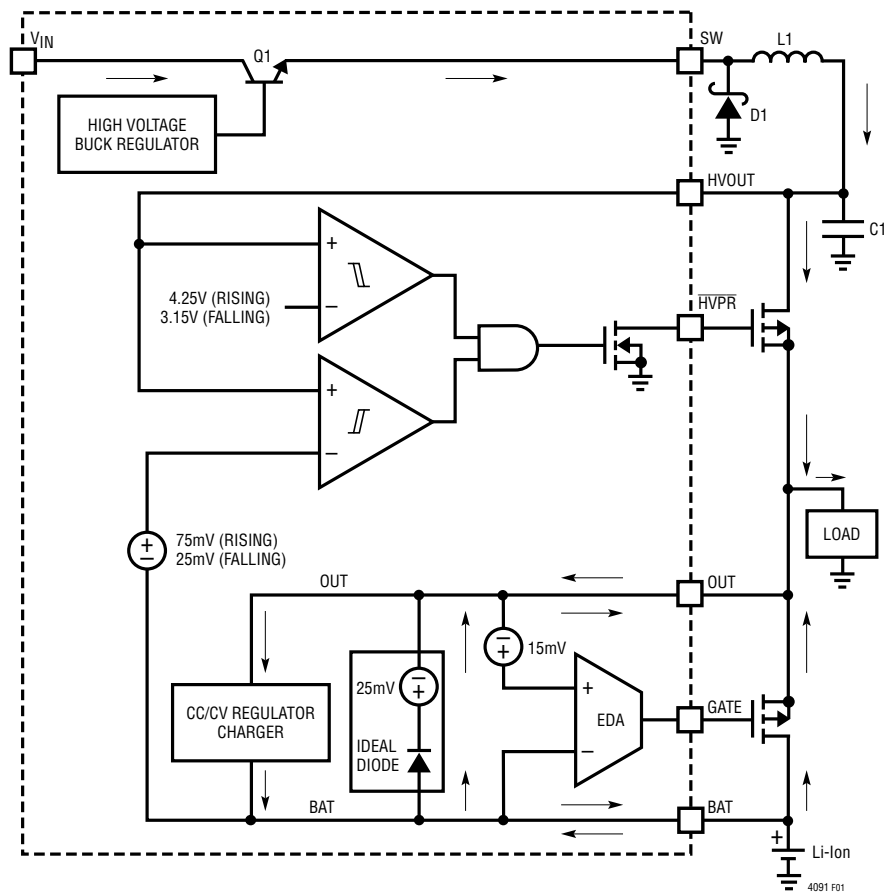

Figure 1. Simplified Block Diagram

## OPERATION

charged until external power is removed. Once external power is removed the output drops until the ideal diode is forward biased. The forward biased ideal diode will then provide the output power to the load from the battery.

### High Voltage Step-Down Regulator

The power delivered from  $V_{IN}$  to HVOUT is controlled by a constant frequency, current mode step down regulator. An external P-channel MOSFET directs this power to OUT and prevents reverse conduction from OUT to HVOUT (and ultimately  $V_{IN}$ ).

An oscillator, with frequency set by  $R_T$ , enables an RS flip-flop, turning on the internal power switch. An amplifier and comparator monitor the current flowing between the  $V_{IN}$  and SW pins, turning the switch off when this current reaches a level determined by the voltage at  $V_C$ . An error amplifier servos the  $V_C$  node to maintain approximately 100mV between HVOUT and BAT. By keeping the voltage across the battery charger low, efficiency is optimized because power lost to the battery charger is minimized and power available to the external load is maximized. If the BAT pin voltage is less than approximately 3.5V, then the error amplifier will servo the  $V_C$  node to provide a constant HVOUT output voltage of about 3.6V. An active clamp on the  $V_C$  node provides current limit. The  $V_C$  node is also clamped to the voltage on the RUN/SS pin: Soft-start is implemented by generating a voltage ramp at the RUN/SS pin using an external resistor and capacitor.

The switch driver operates from either the high voltage input or from the BOOST pin. An external capacitor and internal diode are used to generate a voltage at the BOOST pin that is higher than the input supply. This allows the driver to fully saturate the internal bipolar NPN power switch for efficient operation.

To further optimize efficiency, the buck regulator automatically switches to Burst Mode<sup>®</sup> operation in light load situations. Between bursts, all circuitry associated with controlling the output switch is shut down reducing the input supply current.

The oscillator reduces the switching regulator's operating frequency when the voltage at the HVOUT pin is low (below 3.95V). This frequency foldback helps to control the output current during startup and overload.

The switching regulator contains a  $V_{IN}$  good comparator which trips when the switching regulator is enabled via RUN/SS and the input voltage is sufficient to bias internal circuitry. The  $\overline{VINGD}$  output is an open-collector transistor that is off when no input is present, allowing an external resistor to pull the  $\overline{VINGD}$  pin high.

### Ideal Diode from BAT to OUT

The LTC4091 has an internal ideal diode as well as a controller for an optional external ideal diode. If a battery is the only power supply available then the battery will automatically deliver power to the load via an ideal diode circuit between the BAT and OUT pins. The ideal diode circuit (along with the recommended 68 $\mu$ F capacitor on the OUT pin) allows the LTC4091 to handle large transient loads and wall adapter connect/disconnect events without the need for large bulk capacitors. The ideal diode responds within a few microseconds and prevents the OUT pin voltage from dropping significantly below the BAT pin voltage. A comparison of the I-V curve of the ideal diode and a Schottky diode can be seen in Figure 2.

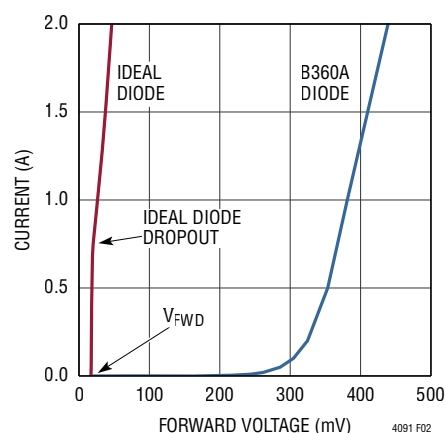

Figure 2. LTC4091 vs Schottky Diode Forward Voltage Drop

## OPERATION

If power to  $V_{IN}$  (primary input) is removed, then all of the application power will be provided by the battery via the ideal diode. A  $68\mu\text{F}$  capacitor at OUT is sufficient to keep a transition from input power to battery power from causing significant output voltage droop. The ideal diode consists of a precision amplifier that enables a large P-channel MOSFET transistor whenever the voltage at OUT is approximately  $25\text{mV}$  ( $V_{FWD}$ ) below the voltage at BAT. The resistance of the internal ideal diode is approximately  $75\text{m}\Omega$ .

If this is sufficient for the application then no external components are necessary. However if more conductance is needed, an external P-channel MOSFET can be added from BAT to OUT. The GATE pin of the LTC4091 drives the gate of the PFET for automatic ideal diode control. The source of the external MOSFET should be connected to OUT and the drain should be connected to BAT. In order to help protect the external MOSFET in overcurrent situations, it should be placed in close thermal contact to the LTC4091. It is important to maintain high impedance on this pin and minimize all leakage paths.

### Battery Charger

The battery charger circuits of the LTC4091 are designed for charging single cell lithium-ion batteries. Featuring an internal P-channel power MOSFET, the charger uses a constant-current/constant-voltage charge algorithm with programmable current and a programmable timer for charge termination. Charge current can be programmed up to  $1.5\text{A}$ . No blocking diode or sense resistor is required. The  $\overline{\text{CHRG}}$  open-drain status output provides information regarding the charging status of the LTC4091 at all times. An NTC input provides the option of charge qualification using battery temperature.

The charge cycle begins when the voltage at the OUT pin rises above the battery voltage and the battery voltage is below the recharge threshold. No charge current actually flows until the OUT voltage is  $100\text{mV}$  above the BAT voltage. At the beginning of the charge cycle, if the battery voltage is below  $2.9\text{V}$ , the charger goes into trickle charge mode to bring the cell voltage up to a safe level for charging.

The charger goes into the fast charge constant-current mode once the voltage on the BAT pin rises above  $2.9\text{V}$ . In constant current mode, the charge current is set by  $R_{\text{PROG}}$ . When the battery approaches the final charge voltage, the charge current begins to decrease as the LTC4091 switches to constant-voltage mode. When the charge current drops below 10% of the programmed value while in constant-voltage mode the  $\overline{\text{CHRG}}$  pin assumes a high impedance state.

A  $4.2\text{V}$  charge voltage is selected by leaving V4P1 high impedance. It is important to minimize all leakage paths around this pin if it is left open. A  $4.1\text{V}$  charge voltage is selected by connecting V4P1 to BAT.

An external capacitor on the TIMER pin sets the total minimum charge time. When this time elapses the charge cycle terminates and the  $\overline{\text{CHRG}}$  pin assumes a high impedance state, if it has not already done so. While charging in constant current mode, if the charge current is decreased by thermal regulation the charge time is automatically increased. In other words, the charge time is extended inversely proportional to the actual charge current delivered to the battery. For Li-Ion and similar batteries that require accurate final charge potential, the internal bandgap reference, voltage amplifier and the resistor divider provide regulation with accuracy typically better than  $\pm 0.5\%$ .

### Trickle Charge and Defective Battery Detection

At the beginning of a charge cycle, if the battery voltage is low (below  $2.9\text{V}$ ) the charger goes into trickle charge reducing the charge current to 10% of the full-scale current. If the low battery voltage persists for one quarter of the total charge time, the battery is assumed to be defective, the charge cycle is terminated and the  $\overline{\text{CHRG}}$  pin output assumes a high impedance state. If for any reason the battery voltage rises above  $\sim 2.9\text{V}$  the charge cycle will be restarted. To restart the charge cycle (i.e., when the dead battery is replaced with a discharged battery), simply remove the input voltage and reapply it or cycle the TIMER pin to 0V. Connecting the TIMER pin to ground disables the battery charger.

## OPERATION

### Programming Charge Current

The formula for the battery charge current is:

$$I_{\text{CHG}} = I_{\text{PROG}} \cdot 52,500 = \frac{V_{\text{PROG}}}{R_{\text{PROG}}} \cdot 52,500$$

where  $V_{\text{PROG}}$  is the PROG pin voltage and  $R_{\text{PROG}}$  is the total resistance from the PROG pin to ground.

For example, if typical 500mA charge current is required, calculate:

$$R_{\text{PROG}} = \frac{1\text{V}}{500\text{mA}} \cdot 52,500 = 105\text{k}$$

For best stability over temperature and time, 1% metal film resistors are recommended. Under trickle charge conditions, this current is reduced to 10% of the full-scale value.

### The Charge Timer

The programmable charge timer is used to terminate the charge cycle. The timer duration is programmed by an external capacitor at the TIMER pin. The charge time is typically:

$$t_{\text{TIMER}}(\text{hours}) = C_{\text{TIMER}}(\text{F}) \cdot R_{\text{PROG}}(\Omega) \cdot 300$$

The timer starts when an input voltage is applied or when leaving shutdown and the voltage on the battery is less than the recharge threshold. At power-up or exiting shutdown with the battery voltage less than the recharge threshold the charge time is a full cycle. If the battery is greater than the recharge threshold the timer will not start and charging is prevented. If after power-up the battery voltage drops below the recharge threshold, or if after a charge cycle the battery voltage is still below the recharge threshold, the charge time is set to one-half of a full cycle.

The LTC4091 has a feature that extends charge time automatically. Charge time is extended if the charge current in constant current mode is reduced due to thermal regulation. This change in charge time is inversely proportional to the

change in charge current. As the LTC4091 approaches constant voltage mode the charge current begins to drop. This change in charge current is due to normal charging operation and does not affect the timer duration.

Once a time-out occurs and the voltage on the battery is greater than the recharge threshold, the charge current stops, and the  $\overline{\text{CHRG}}$  output assumes a high impedance state if it has not already done so.

Connecting the TIMER pin to ground disables the battery charger.

### $\overline{\text{CHRG}}$ Status Output Pin

When the charge cycle starts, the  $\overline{\text{CHRG}}$  pin is pulled to ground by an internal N-channel MOSFET capable of driving an LED. When the charge current drops below 10% of the programmed full charge current while in constant voltage mode, the pin assumes a high impedance state, but charge current continues to flow until the charge time elapses. If this state is not reached before the end of the programmable charge time, the pin will assume a high impedance state when a time-out occurs. The  $\overline{\text{CHRG}}$  current detection threshold can be calculated by the following equation:

$$I_{\text{DETECT}} = \frac{0.1\text{V}}{R_{\text{PROG}}} \cdot 52,500 = \frac{5250\text{V}}{R_{\text{PROG}}}$$

For example, if the full charge current is programmed to 500mA with a 105k PROG resistor the  $\overline{\text{CHRG}}$  pin will change state at a battery charge current of 50mA.

Note: The end-of-charge (EOC) comparator that monitors the charge current latches its decision. Therefore, the first time the charge current drops below 10% of the programmed full charge current while in constant voltage mode, it will toggle  $\overline{\text{CHRG}}$  to a high impedance state. If, for some reason the charge current rises back above the threshold, the  $\overline{\text{CHRG}}$  pin will not resume the strong pull-down state. The EOC latch can be reset by a recharge cycle (i.e.,  $V_{\text{BAT}}$  drops below the recharge threshold).

## OPERATION

### Automatic Recharge

After the battery charger terminates, it will remain off drawing only microamperes of current from the battery. If the portable product remains in this state long enough, the battery will eventually self discharge. To ensure that the battery is always topped off, a charge cycle will automatically begin when the battery voltage falls below  $V_{RECHRG}$  (typically 4.1V or 4V depending on V4P1). To prevent brief excursions below  $V_{RECHRG}$  from resetting the safety timer, the battery voltage must be below  $V_{RECHRG}$  for more than a few milliseconds. The charge cycle and safety timer will also restart if the  $V_{IN}$  UVLO cycles low and then high (e.g.  $V_{IN}$  is removed and then replaced).

### Thermal Regulation

To prevent thermal damage to the IC or surrounding components, an internal thermal feedback loop will automatically decrease the programmed charge current if the die temperature rises to approximately 105°C. Thermal regulation protects the LTC4091 from excessive temperature due to high power operation or high ambient thermal conditions and allows the user to push the limits of the power handling capability with a given circuit board design without risk of damaging the LTC4091 or external components. The benefit of the LTC4091 thermal regulation loop is that charge current can be set according to actual conditions rather than worst-case conditions with the assurance that the battery charger will automatically reduce the current in worst-case conditions.

### Undervoltage Lockout

An internal undervoltage lockout circuit monitors the output voltage (OUT) and can disable the battery charger circuits. The battery charger circuits are disabled until  $V_{OUT}$  exceeds  $V_{BAT}$  by 80mV. The undervoltage lockout comparator has built-in hysteresis.

### NTC Thermistor

The battery temperature is measured by placing a negative temperature coefficient (NTC) thermistor close to the battery pack. To use this feature connect the NTC thermistor,  $R_{NTC}$ , between the NTC pin and ground and a bias resistor,  $R_{NOM}$ , from  $V_{NTC}$  to NTC.  $R_{NOM}$  should be a 1% resistor with a value equal to the value of the chosen NTC thermistor at 25°C (denoted  $R_{25C}$ ).

The LTC4091 will pause charging when the resistance of the NTC thermistor drops to 0.41 times the value of  $R_{25C}$  or approximately 4.1k (for a Vishay Curve 2 thermistor, this corresponds to approximately 50°C). The safety timer also pauses until the thermistor indicates a return to a valid temperature. As the temperature drops, the resistance of the NTC thermistor rises. The LTC4091 is also designed to pause charging (and timer) when the value of the NTC thermistor increases to 2.82 times the value of  $R_{25C}$ . For a Vishay Curve 2 thermistor this resistance, 28.2k, corresponds to approximately 0°C. The hot and cold comparators each have approximately 3°C of hysteresis to prevent oscillation about the trip point. Grounding the NTC pin disables all NTC functionality.

## APPLICATIONS INFORMATION

### Choosing a Charge Voltage for the Battery:

The LTC4091 offers two different charge voltage options: 4.1V and 4.2V. Choosing a higher charge voltage increases the battery capacity to provide a longer product run-time but reduces the battery lifetime, usually measured by the number of charge/discharge cycles. Battery manufacturers usually consider the end of life for a battery to be when the battery capacity drops to 80% of the rated capacity. The curves in Figure 3 show the relationship between cell capacity and cycle life for a typical Li-Ion battery cell. Using 4.2V as the charge voltage, a typical Li-Ion battery is considered at 100% initial capacity but delivers about 500 charge/discharge cycles before the capacity drops to 80%. However, if the same battery uses 4.1V as the charge voltage, it is at 85% initial capacity but the number of charge/discharge cycles can be almost doubled to 1000 before the capacity drops to 80%. Lowering the charge voltage even further to 4V can increase the battery lifetime more than three times to 1800 charge/discharge cycles. Since LTC4091 is a backup product, the battery is likely to spend the majority of its lifetime fully charged. This makes it even more critical to charge at a lower charge voltage to maximize battery lifetime since battery capacity degrades even faster when batteries remain fully charged. Because of the different Li-Ion battery chemistries and other conditions that can affect battery lifetime, the curves shown here are only estimates of the number of charge cycles and battery-capacity levels.

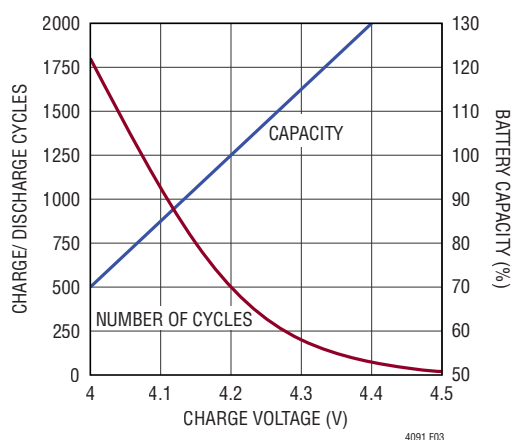

**Figure 3. Battery Cycle Life and Capacity as a Function of Charge Voltage**

### Setting the Switching Frequency

The switching regulator uses a constant-frequency PWM architecture that can be programmed to switch from 200kHz to 2.4MHz by using a resistor tied from the RT pin to ground. The oscillator frequency as a function of  $R_T$  follows the expression below:

$$F_{SW} \text{ (MHz)} = \frac{38}{R_T \text{ (k}\Omega) + 7.5}$$

### Operating Frequency Trade-Offs

Selection of the operating frequency for the high voltage buck regulator is a trade-off between efficiency, component size, minimum dropout voltage, and maximum input voltage. The advantage of high frequency operation is that smaller inductor and capacitor values may be used. The disadvantages are lower efficiency, lower maximum input voltage, and higher dropout voltage. The highest acceptable switching frequency ( $f_{SW(MAX)}$ ) for a given application can be calculated as follows:

$$f_{SW(MAX)} = \frac{V_D + V_{HVOUT}}{t_{ON(MIN)} \cdot (V_D + V_{IN} - V_{SW})}$$

where  $V_{IN}$  is the typical high voltage input voltage,  $V_{HVOUT}$  is the output voltage of the switching regulator,  $V_D$  is the catch diode drop ( $\sim 0.5V$ ), and  $V_{SW}$  is the internal switch drop ( $\sim 0.5V$  at max load). This equation shows that slower switching frequency is necessary to safely accommodate high  $V_{IN}/V_{HVOUT}$  ratio. Also, as shown in the next section, lower frequency allows a lower dropout voltage. The reason input voltage range depends on the switching frequency is because the high voltage switch has non-zero minimum on and off times. The switch can turn on for a minimum of  $\sim 100ns$  and turn off for a minimum of  $\sim 150ns$ . This means that the minimum and maximum duty cycles are:

$$DC_{MIN} = f_{SW} \cdot t_{ON(MIN)}$$

$$DC_{MAX} = 1 - f_{SW} \cdot t_{OFF(MIN)}$$

## APPLICATIONS INFORMATION

where  $f_{SW}$  is the switching frequency,  $t_{ON(MIN)}$  is the minimum switch-on time (~100ns), and  $t_{OFF(MIN)}$  is the minimum switch-off time (~150ns). These equations show that duty cycle range increases when switching frequency is decreased.

A good choice of switching frequency should allow adequate input voltage range (see next section) and keep the inductor and capacitor values small.

### $V_{IN}$ Input Voltage Range

The maximum input voltage range for LTC4091 applications depends on the switching frequency, the Absolute Maximum Ratings of the  $V_{IN}$  and BOOST pins, and the operating mode.

The high voltage switching regulator can operate from input voltages up to 36V, and safely withstand input voltages up to 60V. Note that while  $V_{IN} > 38V$  (typical), the LTC4091 will stop switching, allowing the output to fall out of regulation.

While the high voltage regulator output is in start-up, short-circuit, or other overload conditions, the switching frequency should be chosen according to the following discussion.

For safe operation at inputs up to 60V the switching frequency must be low enough to satisfy  $V_{IN(MAX)} \geq 40V$  according to the following equation. If lower  $V_{IN(MAX)}$  is desired, this equation can be used directly.

$$V_{IN(MAX)} = \frac{V_{HVOUT} + V_D}{f_{SW} \cdot t_{ON(MIN)}} - V_D + V_{SW}$$

where  $V_{IN(MAX)}$  is the maximum operating input voltage,  $V_{HVOUT}$  is the high voltage regulator output voltage,  $V_D$  is the catch diode drop (~0.5V),  $V_{SW}$  is the internal switch drop (~0.5V at max load),  $f_{SW}$  is the switching frequency (set by  $R_T$ ), and  $t_{ON(MIN)}$  is the minimum switch-on time (~150ns). Note that a higher switching frequency will depress the maximum operating input voltage. Conversely, a lower switching frequency will be necessary to achieve safe operation at high input voltages.

If the output is in regulation and no short-circuit, start-up, or overload events are expected, then input voltage transients of up to 60V are acceptable regardless of the switching frequency. In this mode, the LTC4091 may enter pulse-skipping operation where some switching pulses are skipped to maintain output regulation. In this mode the output voltage ripple and inductor current ripple will be higher than in normal operation.

The minimum input voltage is determined by either the high voltage regulator's minimum operating voltage of ~6V or by its maximum duty cycle (see equation in previous section). The minimum input voltage due to duty cycle is:

$$V_{IN(MIN)} = \frac{V_{HVOUT} + V_D}{1 - f_{SW} \cdot t_{OFF(MIN)}} - V_D + V_{SW}$$

where  $V_{IN(MIN)}$  is the minimum input voltage, and  $t_{OFF(MIN)}$  is the minimum switch-off time (~150ns). Note that higher switching frequency will increase the minimum input voltage. If a lower dropout voltage is desired, a lower switching frequency should be used.

### Inductor Selection and Maximum Output Current

A good choice for the inductor value is  $L = 6.8\mu H$  (assuming an 800kHz operating frequency). With this value the maximum load current will be ~2.4A. For details of maximum output current, see Linear Technology Application Note 44. The RMS current rating of the inductor must be greater than the maximum load current and its saturation current should be about 30% higher. Note that the maximum load current will be programmed charge current plus the largest expected application load current. For robust operation in fault conditions, the saturation current should be ~3.5A. To keep efficiency high, the series resistance (DCR) should be less than 0.1Ω. Table 1 lists several vendors and types that are suitable.

## APPLICATIONS INFORMATION

**Table 1. Inductor Vendors**

VENDOR	URL	PART SERIES	TYPE
Murata	www.murata.com	LQH55D	Open
TDK	www.componenttdk.com	SLF7045 SLF10145	Shielded Shielded
Toko	www.toko.com	D62CB D63CB D75C D75F	Shielded Shielded Shielded Open
Sumida	www.sumida.com	CR54 CDRH74 CDRH6D38 CR75	Open Shielded Shielded Open

### Catch Diode

The catch diode conducts current only during switch-off time. Average forward current in normal operation can be calculated from:

$$I_{D(AVG)} = I_{HVOUT} \cdot \frac{(V_{IN} - V_{HVOUT})}{V_{IN}}$$

where  $I_{HVOUT}$  is the output load current. The only reason to consider a diode with a larger current rating than necessary for nominal operation is for the worst-case condition of shorted output. The diode current will then increase to the typical peak switch current. Peak reverse voltage is equal to the regulator input voltage. Use a Schottky diode with a reverse voltage rating greater than the input voltage. The overvoltage protection feature in the high voltage regulator will keep the switch off when  $V_{IN} > 40V$  which allows the use of a 40V rated Schottky even when  $V_{VIN}$  ranges up to 60V. Table 2 lists several Schottky diodes and their manufacturers.

**Table 2. Diode Vendors**

PART NUMBER	$V_R$ (V)	$I_{AVE}$ (A)	$V_F$ AT 1A (MV)	$V_F$ AT 2A (MV)
On Semiconductor MBRM120E MBRM140	20 40	1 1	530 550	595
Diodes Inc. B120 B130 B220 B230 DFLS240L	20 30 20 30 40	1 1 2 2 2	500 500	500 500 500
International Rectifier 10BQQ30 20BQQ30	30 30	1 2	420	470 470

### Switching Regulator Capacitor Selection

Ceramic capacitors are small, robust and have very low ESR providing the best ripple performance. However, ceramic capacitors can cause problems when used with the high voltage switching regulator due to their piezoelectric nature. When in Burst Mode operation, the LTC4091's switching frequency depends on the load current, and at very light loads the LTC4091 can excite the ceramic capacitor at audio frequencies, generating audible noise. Since the LTC4091 operates at a lower current limit during Burst Mode operation, the noise is typically very quiet to a casual ear. If this is unacceptable, use a high performance tantalum or electrolytic capacitor at the output.

Only a small amount of capacitance is required on HVOUT – about 3.3 $\mu$ F. This choice will provide low output ripple and good transient response. Transient performance can be improved with a higher value capacitor if the compensation network is also adjusted to maintain the loop bandwidth. A lower value of output capacitor can be used to save space and cost but transient performance will suffer. See the Switching Regulator Frequency Compensation section to choose an appropriate compensation network.

When choosing a capacitor, look carefully through the data sheet to find out what the actual capacitance is under operating conditions (applied voltage and temperature). A physically larger capacitor, or one with a higher voltage rating, may be required. Low ESR is important, so choose one that is intended for use in switching regulators. The ESR should be specified by the supplier, and should be 0.05 $\Omega$  or less.

## APPLICATIONS INFORMATION

### Switching Regulator Frequency Compensation

The LTC4091 high voltage regulator uses current mode control to regulate the output. This simplifies loop compensation. In particular, the high voltage regulator does not require the ESR of the output capacitor for stability, so you are free to use ceramic capacitors to achieve low output ripple and small circuit size. Frequency compensation is provided by the components tied to the  $V_C$  pin as shown in the Block Diagram. Generally a capacitor ( $C_C$ ) and a resistor ( $R_C$ ) in series to ground are used. In addition, there may be a lower value capacitor in parallel. This capacitor ( $C_F$ ) is not part of the loop compensation but is used to filter noise at the switching frequency, and is required only if a phase-lead capacitor is used or if the output capacitor has high ESR.

Loop compensation determines the stability and transient performance. Designing the compensation network is a bit complicated and the best values depend on the application and in particular the type of output capacitor. A practical approach is to start with the back page schematic and tune the compensation network to optimize performance. Stability should then be checked across all operating conditions, including load current, input voltage and temperature. The LT1375 data sheet contains a more thorough discussion of loop compensation and describes how to test the stability using a transient load. Figure 4 shows the transient response when the load current is stepped from 500mA to 1500mA and back to 500mA.

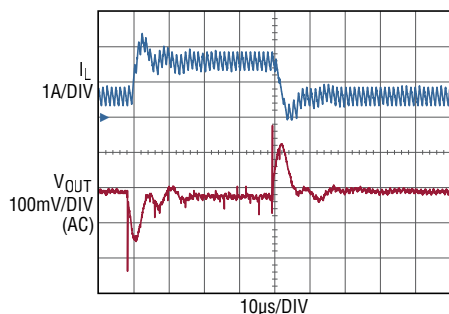

4091 F05

**Figure 4. Transient Load Response of the LTC4091 High Voltage Regulator Back Page Application as the Load Current is Stepped from 500mA to 1500mA.  $V_{HVOUT} = 3.6V$**

### Low Ripple Burst Mode Operation and Pulse-Skipping Mode

The LTC4091 is capable of operating in either low ripple Burst Mode operation or pulse-skipping mode selected by the SYNC pin. Tie the SYNC pin below  $V_{SYNC,L}$  (0.3V) for low ripple Burst Mode operation or above  $V_{SYNC,H}$  (1V) for pulse-skipping mode.

To enhance efficiency at light loads, the LTC4091 can be operated in low ripple Burst Mode operation which keeps the output capacitor charged to the proper voltage while minimizing the input quiescent current. During Burst Mode operation, the LTC4091 delivers single cycle bursts of current to the output capacitor followed by sleep periods where the output power is delivered to the load by the output capacitor. Because the LTC4091 delivers power to the output with single, low current pulses, the output ripple is kept below 15mV for a typical application. As the load current decreases towards a no load condition, the percentage of time that the high voltage regulator operates in sleep mode increases and the average input current is greatly reduced resulting in high efficiency even at very low loads. See Figure 5.

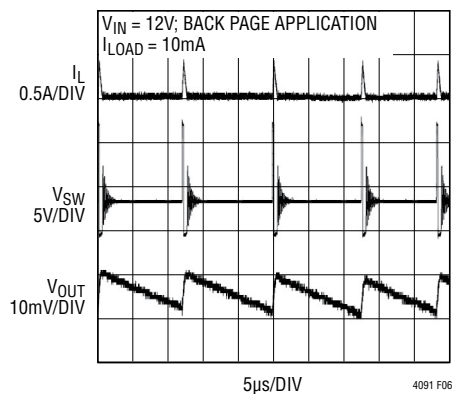

**Figure 5. High Voltage Regulator Burst Mode Operation**

4091fa

## APPLICATIONS INFORMATION

### High Voltage Regulator Burst Mode Operation

At higher output loads (above 90mA for the back page application) the LTC4091 will be running at the frequency programmed by the  $R_T$  resistor, and will be operating in standard PWM mode. The transition between PWM and low ripple Burst Mode operation is seamless, and will not disturb the output voltage.

### Boost Pin Considerations

Capacitor C2 (see Block Diagram) and an internal diode are used to generate a boost voltage that is higher than the input voltage. In most case, a  $0.47\mu\text{F}$  capacitor will work well. The BOOST pin must be at least 2.3V above the SW pin for proper operation.

### High Voltage Regulator Soft-Start

The RUN/SS pin can be used to soft-start the high voltage regulator of the LTC4091, reducing maximum input current during start-up. The RUN/SS pin is driven through an external  $R_C$  filter to create a voltage ramp at this pin. Figure 6 shows the start-up and shut-down waveforms with the soft-start circuit. By choosing a large RC time constant the peak start-up current can be reduced to the current that is required to regulate the output with no overshoot. Choose the value of the resistor so that it can supply  $20\mu\text{A}$  when the RUN/SS pin reaches 2.3V.

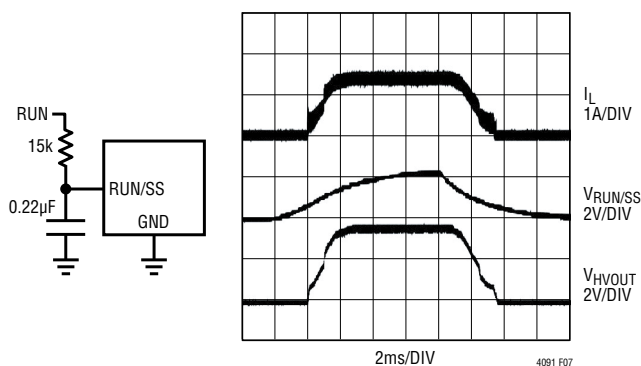

**Figure 6. To Soft-Start the High Voltage Regulator, Add a Resistor and Capacitor to the RUN/SS Pin**

### Automotive Cold-Crank Ride Through

In automotive applications that are expected to experience large dips in supply voltage, such as during a cold-crank event, the high voltage switching regulator can lose regulation resulting in excessive  $V_C$  voltage and consequently excessive output overshoot when  $V_{IN}$  recovers. To prevent overshoot when recovering from a cold-crank event it is necessary to reset the LTC4091's soft-start circuit via the RUN/SS pin. Figure 7 shows an example of a simple circuit that automatically detects a brown-out condition and resets the RUN/SS pin, re-engaging the soft-start feature and preventing damaging output overshoot.

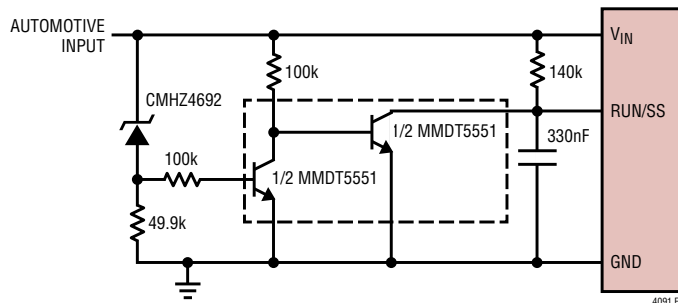

**Figure 7. Cold-Crank Ride Through Circuit**

### Synchronization and Mode

The SYNC pin allows the high voltage regulator to be synchronized to an external clock.

Synchronizing the LTC4091 internal oscillator to an external frequency can be done by connecting a square wave (with 20% to 80% duty cycle) to the SYNC pin. The square wave amplitude should be such that the valleys are below 0.3V and the peaks are above 1V (up to 6V). The high voltage regulator may be synchronized over a 300kHz to 2MHz range. The  $R_T$  resistor should be chosen such that the LTC4091 oscillates 25% slower than the external synchronization frequency to ensure adequate slope compensation. While synchronized, the high voltage regulator will turn on the power switch on positive going edges of the clock.

## APPLICATIONS INFORMATION

When using the SYNC function, there is the potential for inductor current runaway during short-circuit or overload conditions, if the following condition is violated:

$$f_{SW(MAX)} = \frac{V_D + V_{OUT}}{t_{ON(MIN)}(V_D + V_{IN} - V_{SW})}$$

where  $V_{IN(MAX)}$  is the maximum operating input voltage,  $V_{HVOUT}$  is the switching regulator output voltage,  $V_D$  is the catch diode drop ( $\sim 0.5V$ ),  $V_{SW}$  is the internal switch drop ( $\sim 0.5V$  at max load),  $f_{SW}$  is the synchronized switching frequency, and  $t_{ON(MIN)}$  is the minimum switch on time ( $\sim 100ns$ ). Obviously, with a shorted output, it is not difficult to violate this condition.

### Alternate NTC Thermistors and Biasing

The LTC4091 provides temperature qualified charging if a grounded thermistor and a bias resistor are connected to NTC (see Figure 8). By using a bias resistor whose value is equal to the room temperature resistance of the thermistor ( $R_{25C}$ ) the upper and lower temperatures are pre-programmed to approximately  $50^\circ C$  and  $0^\circ C$ , respectively (assuming a Vishay Curve 2 thermistor).

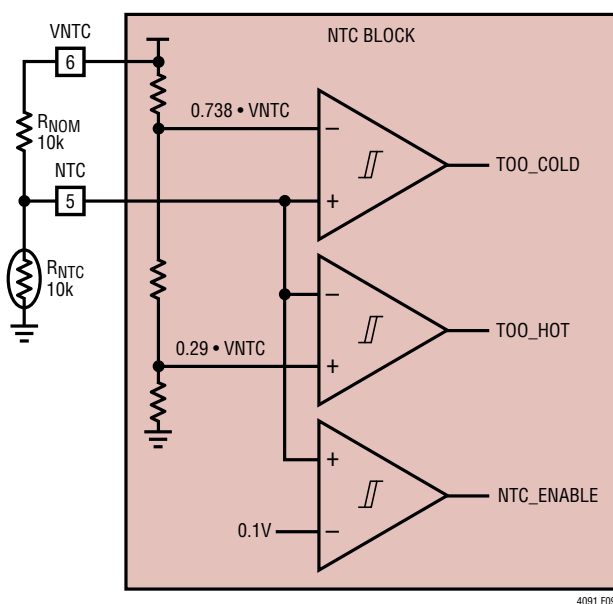

Figure 8. Typical NTC Thermistor Circuit

The upper and lower temperature thresholds can be adjusted by either a modification of the bias resistor value or by adding a second adjustment resistor to the circuit. If only the bias resistor is adjusted, then either the upper or the lower threshold can be modified but not both. The other trip point will be determined by the characteristics of the thermistor. Using the bias resistor in addition to an adjustment resistor, both the upper and the lower temperature trip points can be independently programmed with the constraint that the difference between the upper and lower temperature thresholds cannot decrease. Examples of each technique are given below.

NTC thermistors have temperature characteristics which are indicated on resistance-temperature conversion tables. The Vishay-Dale thermistor NTHS0603N02N1002J, used in the following examples, has a nominal value of  $10k$  and follows the Vishay Curve 2 resistance-temperature characteristic. The LTC4091 trip points were designed to work with thermistors whose resistance-temperature characteristics follow Vishay Dale's R-T Curve 2. The Vishay NTHS0603N02N1002J is an example of such a thermistor. However, Vishay Dale has many thermistor products that follow the R-T Curve 2 characteristic in a variety of sizes. Furthermore, any thermistor whose ratio of  $R_{COLD}$  to  $R_{HOT}$  is about 7.0 will also work (Vishay Dale R-T Curve 2 shows a ratio of  $2.815 / 0.409 = 6.89$ ).

In the explanation below, the following notation is used.

$R_{25C}$  = Value of the Thermistor at  $25^\circ C$

$R_{NTC|COLD}$  = Value of Thermistor at the Cold Trip Point

$R_{NTC|HOT}$  = Value of the Thermistor at the Hot Trip Point

$r_{COLD}$  = Ratio of  $R_{NTC|COLD}$  to  $R_{25C}$

$r_{HOT}$  = Ratio of  $R_{NTC|HOT}$  to  $R_{25C}$

$R_{NOM}$  = Primary Thermistor Bias Resistor (see Figure 9)

$R_1$  = Optional Temperature Range Adjustment Resistor (see Figure 9)

## APPLICATIONS INFORMATION

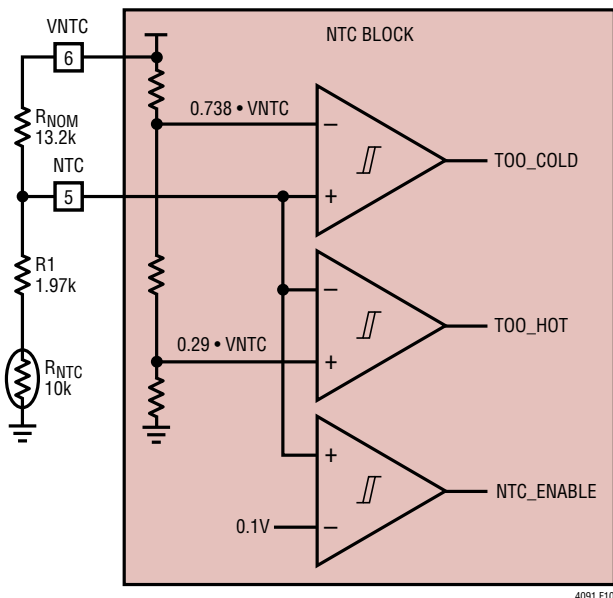

**Figure 9. NTC Thermistor Circuit with Additional Dilution Resistor**

The trip points for the LTC4091's temperature qualification are internally programmed at  $0.29 \cdot V_{NTC}$  for the hot threshold and  $0.74 \cdot V_{NTC}$  for the cold threshold.

Therefore, the hot trip point is set when:

$$\frac{R_{NTC|HOT}}{R_{NOM} + R_{NTC|HOT}} \cdot V_{NTC} = 0.29 \cdot V_{NTC}$$

and the cold trip point is set when:

$$\frac{R_{NTC|COLD}}{R_{NOM} + R_{NTC|COLD}} \cdot V_{NTC} = 0.74 \cdot V_{NTC}$$

Solving these equations for  $R_{NTC|COLD}$  and  $R_{NTC|HOT}$  results in the following:

$$R_{NTC|HOT} = 0.409 \cdot R_{NOM}$$

and

$$R_{NTC|COLD} = 2.815 \cdot R_{NOM}$$

By setting  $R_{NOM}$  equal to  $R_{25C}$ , the above equations result in  $r_{HOT} = 0.409$  and  $r_{COLD} = 2.815$ . Referencing these ratios to the Vishay Resistance-Temperature Curve 2 chart gives

a hot trip point of about  $50^{\circ}\text{C}$  and a cold trip point of about  $0^{\circ}\text{C}$ . The difference between the hot and cold trip points is approximately  $50^{\circ}\text{C}$ .

By using a bias resistor,  $R_{NOM}$ , different in value from  $R_{25C}$ , the hot and cold trip points can be moved in either direction. The temperature span will change somewhat due to the nonlinear behavior of the thermistor. The following equations can be used to easily calculate a new value for the bias resistor:

$$R_{NOM} = \frac{r_{HOT}}{0.409} \cdot R_{25C}$$

$$R_{NOM} = \frac{r_{COLD}}{2.815} \cdot R_{25C}$$

where  $r_{HOT}$  and  $r_{COLD}$  are the resistance ratios at the desired hot and cold trip points. Note that these equations are linked. Therefore, only one of the two trip points can be chosen, the other is determined by the default ratios designed in the IC. Consider an example where a  $40^{\circ}\text{C}$  hot trip point is desired.

From the Vishay Curve 2 R-T characteristics,  $r_{HOT}$  is 0.5758 at  $40^{\circ}\text{C}$ . Using the above equation,  $R_{NOM}$  should be set to 14k. With this value of  $R_{NOM}$ , the cold trip point is about  $-7^{\circ}\text{C}$ . Notice that the span is now  $47^{\circ}\text{C}$  rather than the previous  $50^{\circ}\text{C}$ . This is due to the increase in temperature gain of the thermistor as absolute temperature decreases.

The upper and lower temperature trip points can be independently programmed by using an additional dilution resistor as shown in Figure 9. The following formulas can be used to compute the values of  $R_{NOM}$  and  $R1$ :

$$R_{NOM} = \frac{r_{COLD} - r_{HOT}}{2.815} \cdot R_{25C}$$

$$R1 = 0.409 \cdot R_{NOM} - r_{HOT} \cdot R_{25C}$$

For example, to set the trip points to  $-5^{\circ}\text{C}$  and  $55^{\circ}\text{C}$  with a Vishay Curve 2 thermistor choose

$$R_{NOM} = \frac{3.532 - 0.3467}{2.815 - 0.409} \cdot 10\text{k} = 13.2\text{k}$$

## APPLICATIONS INFORMATION

the nearest 1% value is 13.3k.

$$R1 = 0.409 \cdot 13.3k - 0.3467 \cdot 10k = 1.97k$$

the nearest 1% value is 1.96k. The final solution is shown in Figure 10 and results in an upper trip point of 55°C and a lower trip point of -5°C.

### Power Dissipation and High Temperature Considerations

The die temperature of the LTC4091 must be lower than the maximum rating of 125°C. This is generally not a concern unless the ambient temperature is above 85°C. The total power dissipated inside the LTC4091 depends on many factors, including input voltage, battery voltage, programmed charge current and load current.

When powered from the primary source, the power dissipation can be estimated by calculating the regulator power loss from an efficiency measurement, and subtracting the catch diode loss.

$$P_D = (1 - \eta) \cdot (V_{HVOUT} \cdot (I_{BAT} + I_{OUT})) - V_D \cdot \left(1 - \frac{V_{HVOUT}}{V_{VIN}}\right) \cdot (I_{BAT} + I_{OUT}) + 0.1V \cdot I_{BAT}$$

where  $\eta$  is the efficiency of the high voltage regulator and  $V_D$  is the forward voltage of the catch diode at  $I = I_{BAT} + I_{OUT}$ . The first term corresponds to the power lost in converting  $V_{VIN}$  to  $V_{HVOUT}$ , the second term subtracts the catch diode loss, and the third term is the power dissipated in the battery charger. For a typical application, an example of this calculation would be:

$$P_D = (1 - 0.87) \cdot (3.8V \cdot (1A + 0.6A)) - 0.4V \cdot \left(1 - \frac{4V}{12V}\right) \cdot (1A + 0.6A) + 0.1V \cdot 1A = 0.46W$$

This example assumes 87% efficiency,  $V_{IN} = 12V$ ,  $V_{BAT} = 3.7V$  ( $V_{HVOUT}$  is about 3.8V),  $I_{BAT} = 1A$ ,  $I_{OUT} = 600mA$  resulting in just under 0.5W total dissipation.

It is important to solder the exposed backside of the package to a ground plane. This ground should be tied to other copper layers below with thermal vias; these layers will spread the heat dissipated by the LTC4091. Additional vias should be placed near the catch diode. Adding more copper to the top and bottom layers and tying this copper to the internal planes with vias can reduce thermal resistance further. With these steps, the thermal resistance from die (i.e., junction) to ambient can be reduced to  $\theta_{JA} = 40^\circ C/W$ .

### Board Layout Considerations

As discussed in the previous section, it is critical that the exposed metal pad on the backside of the LTC4091 package be soldered to the PC board ground. Furthermore, proper operation and minimum EMI requires a careful printed circuit board (PCB) layout. Note that large, switched currents flow in the power switch (between the  $V_{IN}$  and SW pins), the catch diode and the  $V_{IN}$  input capacitor. These components, along with the inductor and output capacitor, should be placed on the same side of the circuit board, and their connections should be made on that layer. Place a local, unbroken ground plane below these components. The loop formed by these components should be as small as possible.

Additionally, the SW and BOOST nodes should be kept as small as possible. Linear Technology demonstration board DC2558A shows an example of a preferred printed circuit board layout. Gerber files can be downloaded at: <http://www.linear.com/product/LTC4091#demoboards>.

High frequency currents, such as the high voltage input current of the LTC4091, tend to find their way along the ground plane on a mirror path directly beneath the incident path on the top of the board. If there are slits or cuts in the ground plane due to other traces on that layer, the current will be forced to go around the slits. If high frequency currents are not allowed to flow back through their natural least-area path, excessive voltage will build up and radiated emissions will occur. See Figure 10.

## APPLICATIONS INFORMATION

### $V_{IN}$ Bypass Capacitor

Many types of capacitors can be used for input bypassing; while recommended, caution must be exercised when using multilayer ceramic capacitors. Because of the self-resonant and high Q characteristics of some types of ceramic capacitors, high voltage transients can be generated under some start-up conditions, such as from connecting the charger input to a hot power source. For more information, refer to Application Note 88.

### Battery Charger Stability Considerations

The constant-voltage mode feedback loop is stable without any compensation when a battery is connected with low impedance leads. Excessive lead length, however, may add enough series inductance to require a bypass capacitor of at least  $1\mu\text{F}$  from BAT to GND. Furthermore, a  $100\mu\text{F}$  capacitor with a  $50\text{m}\Omega$  series resistor to GND is recommended at the BAT pin to keep ripple voltage low when the battery is disconnected.

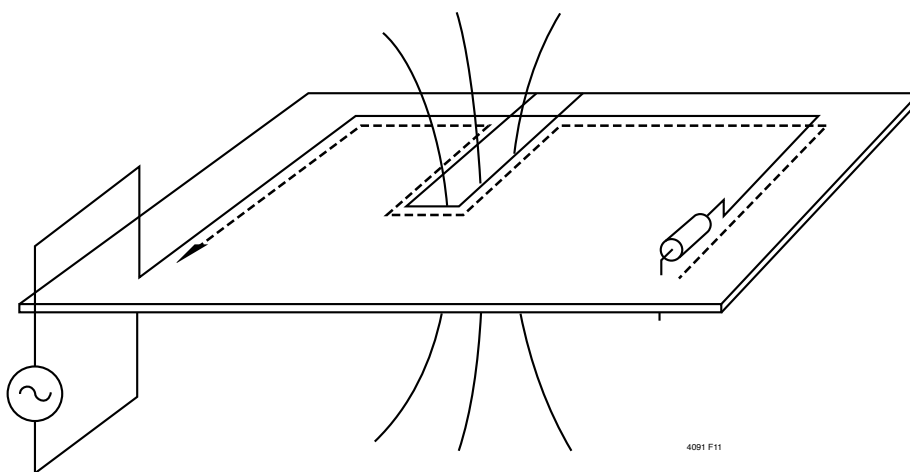
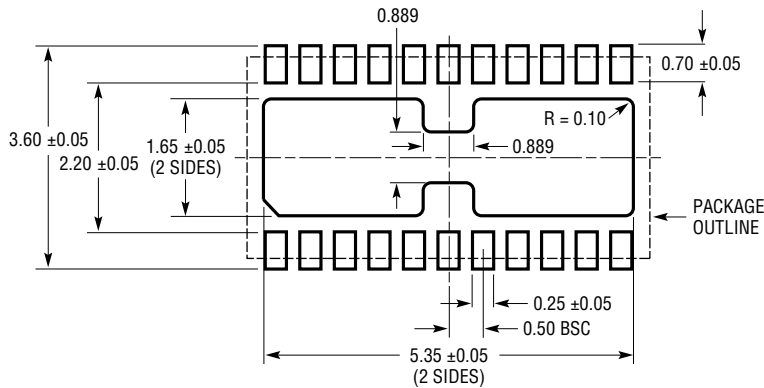

**Figure 10. Ground Currents Follow Their Incident Path at High Speed. Slices in the Ground Plane Cause High Voltage and Increased Emissions.**

## PACKAGE DESCRIPTION

Please refer to <http://www.linear.com/product/LTC4091#packaging> for the most recent package drawings.

### DJC Package 22-Lead Plastic DFN (6mm × 3mm) (Reference LTC DWG # 05-08-1714 Rev 0)



#### RECOMMENDED SOLDER PAD PITCH AND DIMENSIONS

##### NOTE:

1. DIMENSIONS ARE IN MILLIMETERS
2. APPLY SOLDER MASK TO AREAS THAT ARE NOT SOLDERED
3. DRAWING IS NOT TO SCALE

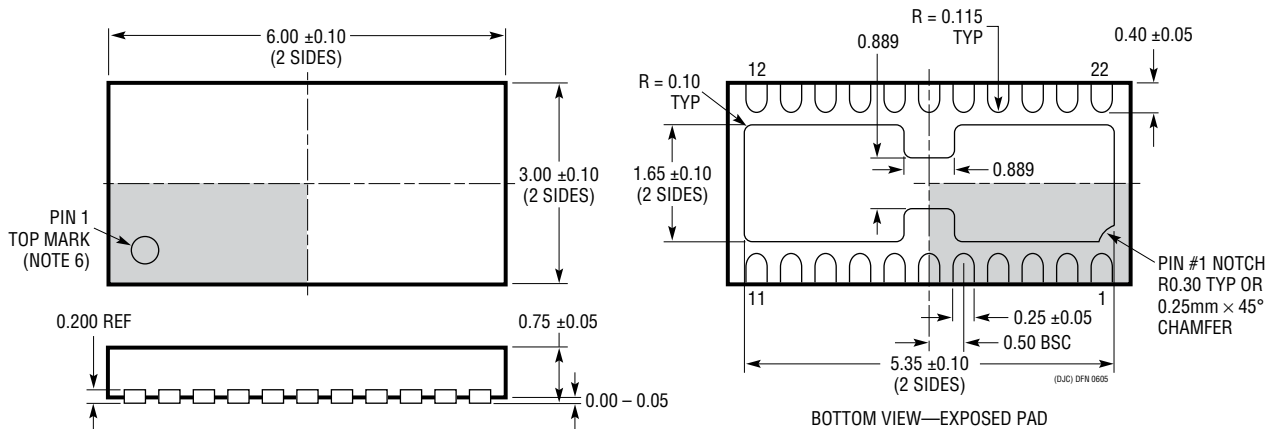

##### NOTE:

1. DRAWING PROPOSED TO BE MADE VARIATION OF VERSION (WXXX) IN JEDEC PACKAGE OUTLINE M0-229
2. DRAWING NOT TO SCALE
3. ALL DIMENSIONS ARE IN MILLIMETERS
4. DIMENSIONS OF EXPOSED PAD ON BOTTOM OF PACKAGE DO NOT INCLUDE MOLD FLASH. MOLD FLASH, IF PRESENT, SHALL NOT EXCEED 0.15mm ON ANY SIDE
5. EXPOSED PAD SHALL BE SOLDER PLATED
6. SHADED AREA IS ONLY A REFERENCE FOR PIN 1 LOCATION ON TOP AND BOTTOM OF PACKAGE

**REVISION HISTORY**

REV	DATE	DESCRIPTION	PAGE NUMBER
A	08/16	Modified $I_{VGLK}$ conditions	4
		Changed $\theta_{JA}$ from 40°C/W to 31.8°C/W	4
		Change Minimum On Time from 150ns to 100ns	15
		Change Minimum On Time from 150ns to 100ns	16
		Add approximate symbol "~", to 150ns minimum switch-off time	16
		Correct table numbering	16, 17
		Correct figure numbering	18-23
		Change Minimum On Time from 150ns to 100ns	20
		Correct $R_{NTC HOT}$ to $R_{NTC COLD}$	21

## TYPICAL APPLICATION

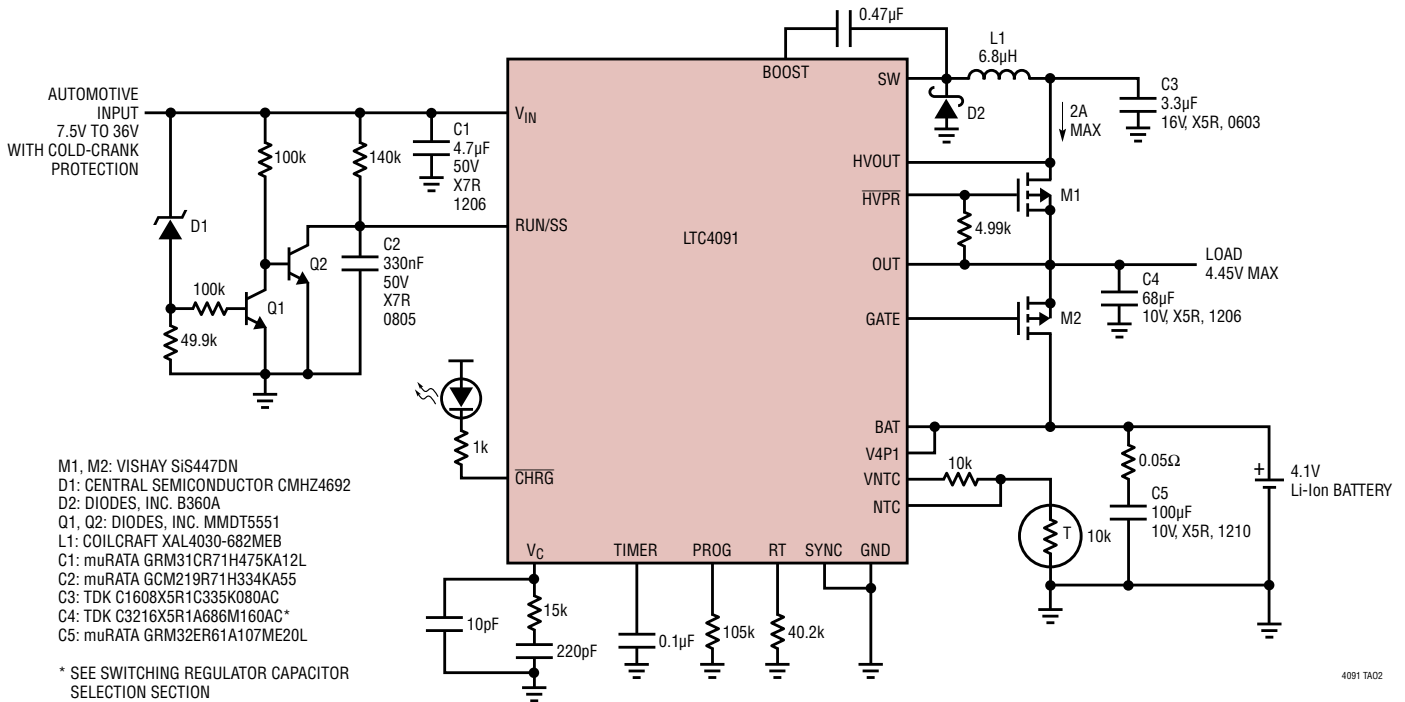

## RELATED PARTS

PART NUMBER	DESCRIPTION	COMMENTS
<a href="#">LTC3226</a>	Boost Charge Pump + PowerPath Manager for SCaps	$I_{CHARGE}$ : 0.33A, $V_{IN}$ : 2.5V to 5.5V, $V_{OUT}$ : 2.5V to 5.5V
<a href="#">LTC3355</a>	Buck SCap Charger + Boost Backup	$I_{CHARGE}$ : 1A, $V_{IN}$ : 3V to 20V, $V_{OUT}$ : 2.7V to 5.5V
<a href="#">LTC3110</a>	Bi-Directional Buck-Boost + PowerPath Manager for SCaps	$I_{CHARGE}$ : 2A, $V_{IN}$ : 0.1V to 5.5V, $V_{OUT}$ : 1.8V to 5.5V
<a href="#">LTC3643</a>	Bi-Directional Boost Charger/Buck Backup, Electrolytic Caps	$I_{CHARGE}$ : 2A, $V_{IN}$ : 3V to 17V, $V_{OUT}$ : Up to 40V
<a href="#">LTC4040</a>	Buck Battery Charger + Boost Backup for Li Batteries	$I_{CHARGE}$ : 2.5A, $V_{IN}$ : 3.5V to 5.5V, $V_{OUT}$ : 3.5V to 5V
<a href="#">LTC3128</a>	Buck-Boost SCap Charger	$I_{CHARGE}$ : 3A, $V_{IN}$ : 1.7V to 5.5V, $V_{OUT}$ : 1.8V to 5.5V
<a href="#">LTC4425</a>	Linear/Ideal Diode SCap Charger	$I_{CHARGE}$ : 3A, $V_{IN}$ : 1.7V to 5.5V, $V_{OUT}$ : 2.7V to 5.5V
<a href="#">LTC4110</a>	Bi-Directional Buck-Boost Flyback Controller	$I_{CHARGE}$ : 3A, $V_{IN}$ : 4.5V to 19V, $V_{OUT}$ : 2.7V to 19V
<a href="#">LTC3350</a>	Bi-Directional Controller + Monitor + PowerPath for SCaps	$I_{CHARGE}$ : 10A+, $V_{IN}$ : 4.5V to 35V, $V_{OUT}$ : 4V to 35V
<a href="#">LTC4089</a>	USB Power Manager with High Voltage Switching Charger	Seamless Transition Between Power Sources: Li-Ion Battery, USB and 6V to 36V External Supply, High Efficiency, 1.2A Charger from 6V to 36V Input with Adaptive Output Control
<a href="#">LTC4090</a>	USB Power Manager with 2A High Voltage Bat-Track™ Buck Charger	Seamless Transition Between Power Sources: Li-Ion Battery, USB and 6V to 38V Supply (60V Max), 2A Output High Voltage Back Regulator with Bat-Track Adaptive Output Control

## Looking for pricing, stock, or lifecycle information?

Click below to explore more details on WIN SOURCE:

- ⊖ [View LTC4091EDJC#PBF on WIN SOURCE](#)
- ⊖ [Analog Devices Inc. Information](#)

## Optimize Your Supply Chain with WIN SOURCE Solutions

- ✓ Global Sourcing Solution
- ✓ Obsolete Management
- ✓ Cost Control Management
- ✓ Shortage Management
- ✓ Alternative Solution
- ✓ Excess Inventory Management