



**THE DATASHEET OF
LTC4012IUF-2#PBF**



High Efficiency, Multi-Chemistry Battery Charger with PowerPath Control

FEATURES

- General Purpose Battery Charger Controller
- Efficient 550kHz Synchronous Buck PWM Topology
- $\pm 0.5\%$ Output Float Voltage Accuracy
- Programmable Charge Current: 4% Accuracy
- Programmable AC Adapter Current Limit: 3% Accuracy
- No Audible Noise with Ceramic Capacitors
- INFET Low Loss Ideal Diode PowerPath™ Control
- Wide Input Voltage Range: 6V to 28V
- Wide Output Voltage Range: 2V to 28V
- Indicator Outputs for AC Adapter Present, Charging, C/10 Current Detection and Input Current Limiting
- Analog Charge Current Monitor
- Micropower Shutdown
- 20-Pin 4mm × 4mm × 0.75mm QFN Package

APPLICATIONS

- Notebook Computers
- Portable Instruments
- Battery Backup Systems

LT, LTC, LTM, Linear Technology and the Linear logo are registered trademarks and PowerPath and ThinSOT are trademarks of Linear Technology Corporation. All other trademarks are the property of their respective owners. Protected by U.S. Patents including 5723970.

DESCRIPTION

The LTC4012 is a constant-current/constant-voltage battery charger controller. It uses a synchronous quasi-constant frequency PWM control architecture that will not generate audible noise with ceramic bulk capacitors. Charge current is set by external resistors and can be monitored as an output voltage. With no built-in termination, the LTC4012 family charges a wide range of batteries under external control.

The LTC4012 features fully adjustable output voltage, while the LTC4012-1 and LTC4012-2 can be pin-programmed for Lithium-Ion/Polymer battery packs of 1-, 2-, 3- or 4-series cells. The LTC4012-1 provides output voltage of 4.1V/cell and the LTC4012-2 is a 4.2V/cell version.

The device includes AC adapter input current limiting, which maximizes charge rate for a fixed input power level. An external sense resistor programs the input current limit, and the \overline{ICL} status pin indicates reduced charge current as a result of AC adapter current limiting. Ideal diode control at the adaptor input improves charger efficiency.

The \overline{CHRG} status pin is active during all charging modes, including special indication for low charge current.

TYPICAL APPLICATION

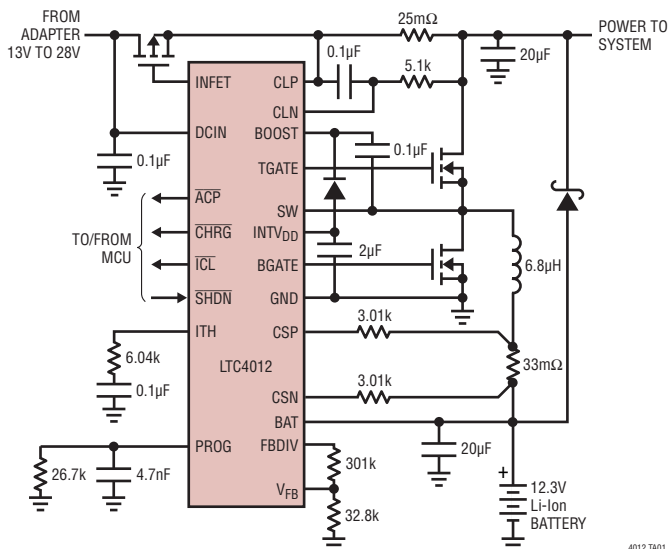

Efficiency at DCIN = 20V

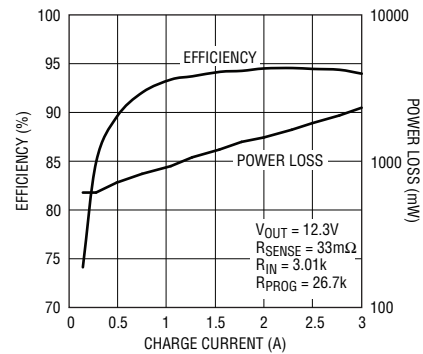

PART	PIN NAME	
	INFET	DCDIV
LTC4009		X
LTC4012	X	X

4012 TA02

4012 TA01

4012fa

LTC4012/ LTC4012-1/LTC4012-2

ABSOLUTE MAXIMUM RATINGS

(Note 1)

DCIN	-14V to 30V
DCIN to CLP	-32V to 20V
CLP, CLN or SW to GND	-0.3V to 30V
CLP to CLN	±0.3V
CSP, CSN or BAT to GND	-0.3V to 28V
CSP to CSN	±0.3V
BOOST to GND	-0.3V to 36V
BOOST to SW	-0.3V to 7V

$\overline{\text{SHDN}}$, FVS0, FVS1 or V_{FB} to GND	-0.3V to 7V
$\overline{\text{ACP}}$, $\overline{\text{CHRG}}$ or $\overline{\text{ICL}}$ to GND	-0.3V to 30V
Operating Temperature Range (Note 2)	-40°C to 125°C
Junction Temperature (Note 3)	125°C
Storage Temperature Range	-65°C to 150°C

PIN CONFIGURATION

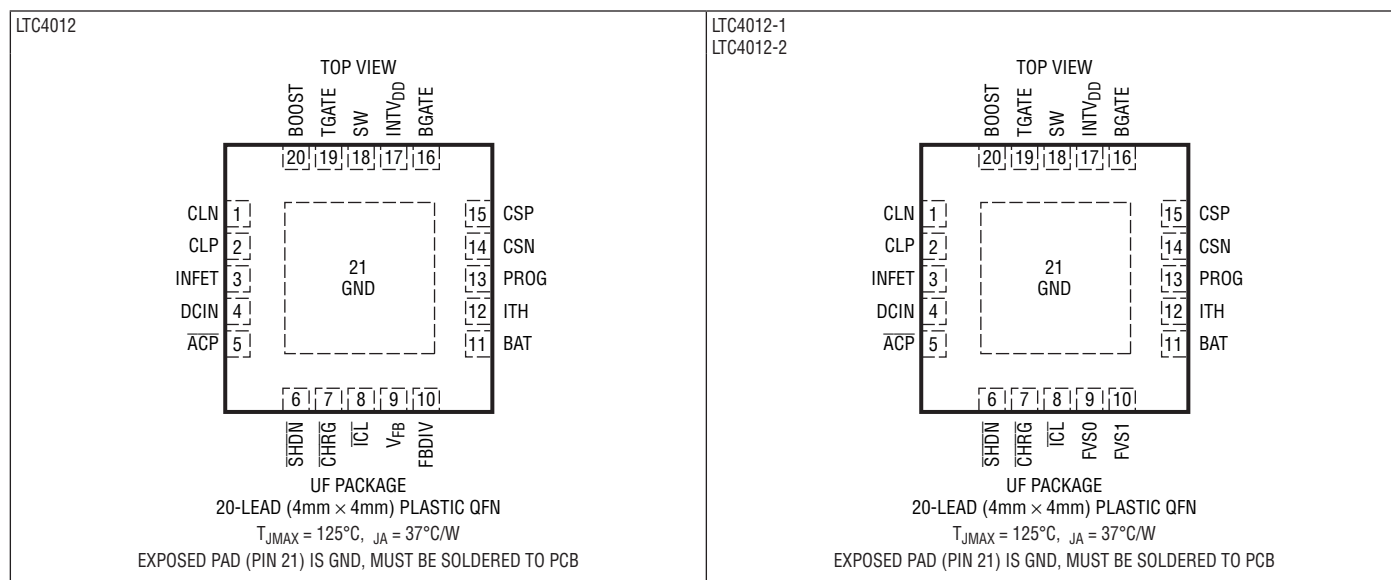

ORDER INFORMATION

LEAD FREE FINISH	TAPE AND REEL	PART MARKING*	PACKAGE DESCRIPTION	TEMPERATURE RANGE
LTC4012CUF#PBF	LTC4012CUF#TRPBF	4012	20-Lead (4mm × 4mm) Plastic QFN	0°C to 85°C
LTC4012CUF-1#PBF	LTC4012CUF-1#TRPBF	40121	20-Lead (4mm × 4mm) Plastic QFN	0°C to 85°C
LTC4012CUF-2#PBF	LTC4012CUF-2#TRPBF	40122	20-Lead (4mm × 4mm) Plastic QFN	0°C to 85°C
LTC4012IUF#PBF	LTC4012IUF#TRPBF	4012	20-Lead (4mm × 4mm) Plastic QFN	-40°C to 125°C
LTC4012IUF-1#PBF	LTC4012IUF-1#TRPBF	40121	20-Lead (4mm × 4mm) Plastic QFN	-40°C to 125°C
LTC4012IUF-2#PBF	LTC4012IUF-2#TRPBF	40122	20-Lead (4mm × 4mm) Plastic QFN	-40°C to 125°C

Consult LTC Marketing for parts specified with wider operating temperature ranges. *The temperature grade is identified by a label on the shipping container. Consult LTC Marketing for information on non-standard lead based finish parts.

For more information on lead free part marking, go to: <http://www.linear.com/leadfree/>

For more information on tape and reel specifications, go to: <http://www.linear.com/tapeandreel/>

ELECTRICAL CHARACTERISTICS The ● denotes the specifications which apply over the full operating temperature range, otherwise specifications are at $T_A = 25^\circ\text{C}$. $\text{DCIN} = 20\text{V}$, $\text{BAT} = 12\text{V}$, $\text{GND} = 0\text{V}$ unless otherwise noted. (Note 2)

SYMBOL	PARAMETER	CONDITIONS	MIN	TYP	MAX	UNITS	
Charge Voltage Regulation							
V_{TOL}	V_{BAT} Accuracy (See Test Circuits)	LTC4012		-0.5	0.5	%	
		C-Grade	●	-0.8	0.8	%	
		I-Grade	●	-1.0	1.0	%	
		LTC4012-1/LTC4012-2		-0.6	0.6	%	
		C-Grade	●	-0.8	0.8	%	
		FVS1 = 0V, FVS0 = 0V, I-Grade	●	-1.1	1.1	%	
		FVS1 = 0V, FVS1 = 5V, I-Grade	●	-1.15	1.15	%	
FVS1 = 5V, FVS0 = 0V, I-Grade	●	-1.25	1.25	%			
FVS1 = 5V, FVS1 = 5V, I-Grade	●	-1.35	1.35	%			
I_{VFB}	V_{FB} Input Bias Current	$V_{\text{FB}} = 1.2\text{V}$		±20		nA	
R_{ON}	FBDIV On Resistance	$I_{\text{LOAD}} = 100\mu\text{A}$	●	85	190	Ω	
$I_{\text{LEAK-FBDIV}}$	FBDIV Output Leakage Current	$\overline{\text{SHDN}} = 0\text{V}$, $\text{FBDIV} = 0\text{V}$	●	-1	0	1	μA
V_{BOV}	V_{FB} Overvoltage Threshold	LTC4012	●	1.235	1.281	1.32	V
	BAT Overvoltage Threshold	LTC4012-1/LTC4012-2, Relative to Selected Output Voltage	●	103	106	109	%
Charge Current Regulation							
I_{TOL}	Charge Current Accuracy with $R_{\text{IN}} = 3.01\text{k}$, $6\text{V} < \text{BAT} < 18\text{V}$ (LTC4012) $6\text{V} < \text{BAT} < 15\text{V}$ (LTC4012-1, LTC4012-2)	$R_{\text{PROG}} = 26.7\text{k}$		-4	4	%	
		C-Grade	●	-5	5	%	
		I-Grade	●	-9.5	9.5	%	
		$V_{\text{SENSE}} = 0\text{mV}$, $\text{PROG} = 1.2\text{V}$		-12.75	-11.67	-10.95	μA
A_{I}	Current Sense Amplifier Gain (PROG ΔI) with $R_{\text{IN}} = 3.01\text{k}$, $6\text{V} < \text{BAT} < 18\text{V}$ (LTC4012) $6\text{V} < \text{BAT} < 15\text{V}$ (LTC4012-1, LTC4012-2)	V_{SENSE} Step from 0mV to 5mV, $\text{PROG} = 1.2\text{V}$		-1.78	-1.66	-1.54	μA
$V_{\text{CS-MAX}}$	Maximum Peak Current Sense Threshold Voltage per Cycle ($R_{\text{IN}} = 3.01\text{k}$)	ITH = 2V, C-Grade	●	140	195	250	mV
		ITH = 2V, I-Grade	●	125		265	mV
		ITH = 5V	●		325	430	mV
V_{C10}	C/10 Indicator Threshold Voltage	PROG Falling		340	400	460	mV
V_{REV}	Reverse Current Threshold Voltage	PROG Falling		180	253	295	mV
Input Current Regulation							
V_{CL}	Current Limit Threshold	CLP – CLN		97	100	103	mV
		C-Grade	●	96	100	104	mV
		I-Grade	●	92		108	mV
I_{CLN}	CLN Input Bias Current	CLN = CLP		±100		nA	
V_{ICL}	$\overline{\text{ICL}}$ Indicator Threshold	(CLP – CLN) – V_{CL}		-8	-5	-2	mV
CLP Supply							
OVR	Operating Voltage Range			6	28	V	
V_{UVLO}	CLP Undervoltage Lockout Threshold	CLP Increasing	●	4.65	4.85	5.25	V
$V_{\text{UV(HYST)}}$	UVLO Threshold Hysteresis			200		mV	
I_{CLPO}	CLP Operating Current	CLP = 20V, No Gate Loads		2	3	mA	
Shutdown							
V_{ACP}	AC Present Threshold Voltage	DCIN – BAT, DCIN Rising		350	500	650	mV
		C-Grade	●	300		700	mV
		I-Grade	●				
$V_{\text{ACP(HYST)}}$	ACP Threshold Hysteresis Voltage			200		mV	
V_{IL}	$\overline{\text{SHDN}}$ Input Voltage Low		●		300	mV	
V_{IH}	$\overline{\text{SHDN}}$ Input Voltage High		●	1.4		V	

LTC4012/ LTC4012-1/LTC4012-2

ELECTRICAL CHARACTERISTICS

The ● denotes the specifications which apply over the full operating temperature range, otherwise specifications are at $T_A = 25^\circ\text{C}$. $\text{DCIN} = 20\text{V}$, $\text{BAT} = 12\text{V}$, $\text{GND} = 0\text{V}$ unless otherwise noted. (Note 2)

SYMBOL	PARAMETER	CONDITIONS		MIN	TYP	MAX	UNITS
R_{IN}	SHDN Pull-Down Resistance				40		$\text{k}\Omega$
I_{CLPS}	CLP Shutdown Current	CLP = 12V, DCIN = 0V SHDN = 0V	●		15 350	26 500	μA μA
$I_{\text{LEAK-BAT}}$	BAT Leakage Current	SHDN = 0V or DCIN = 0V, $0\text{V} \leq \text{CSP} = \text{CSN} = \text{BAT} \leq 18\text{V}$	●	-1.5	0	1.5	μA
$I_{\text{LEAK-CSN}}$	CSN Leakage Current	SHDN = 0V or DCIN = 0V, $0\text{V} \leq \text{CSP} = \text{CSN} = \text{BAT} \leq 20\text{V}$	●	-1.5	0	1.5	μA
$I_{\text{LEAK-CSP}}$	CSP Leakage Current	SHDN = 0V or DCIN = 0V, $0\text{V} \leq \text{CSP} = \text{CSN} = \text{BAT} \leq 20\text{V}$	●	-1.5	0	1.5	μA
$I_{\text{LEAK-SW}}$	SW Leakage Current	SHDN = 0V or DCIN = 0V, $0\text{V} \leq \text{SW} \leq 20\text{V}$	●	-1	0	2	μA
INTV_{DD} Regulator							
INTV _{DD}	Output Voltage	No Load	●	4.85	5	5.15	V
ΔV_{DD}	Load Regulation	$I_{\text{DD}} = 20\text{mA}$			-0.4	-1	%
I_{DD}	Short-Circuit Current (Note 5)	INTV _{DD} = 0V		50	85	130	mA
Switching Regulator							
I_{ITH}	ITH Current	ITH = 1.4V			-40/+90		μA
f_{TYP}	Typical Switching Frequency			467	550	633	kHz
f_{MIN}	Minimum Switching Frequency	$C_{\text{LOAD}} = 3.3\text{nF}$		20	25		kHz
DC_{MAX}	Maximum Duty Cycle	$C_{\text{LOAD}} = 3.3\text{nF}$		98	99		%
$t_{\text{R-TG}}$	TGATE Rise Time	$C_{\text{LOAD}} = 3.3\text{nF}$, 10% – 90%			60	110	ns
$t_{\text{F-TG}}$	TGATE Fall Time	$C_{\text{LOAD}} = 3.3\text{nF}$, 90% – 10%			50	110	ns
$t_{\text{R-BG}}$	BGATE Rise Time	$C_{\text{LOAD}} = 3.3\text{nF}$, 10% – 90%			60	110	ns
$t_{\text{F-BG}}$	BGATE Fall Time	$C_{\text{LOAD}} = 3.3\text{nF}$, 90% – 10%			60	110	ns
t_{NO}	TGATE, BGATE Non-Overlap Time	$C_{\text{LOAD}} = 3.3\text{nF}$, 10% – 10%			110		ns
PowerPath Control							
I_{DCIN}	DCIN Input Current	$0\text{V} \leq \text{DCIN} \leq \text{CLP}$	●	-10		60	μA
V_{FTO}	Forward Turn-On Voltage (DCIN Detection Threshold)	DCIN-CLP, DCIN rising	●	15		60	mV
V_{FR}	Forward Regulation Voltage	DCIN-CLP	●	15	25	35	mV
V_{RTO}	Reverse Turn-Off Voltage	DCIN-CLP, DCIN falling	●	-45	-25	-15	mV
$V_{\text{OL(INFET)}}$	INFET Output Low Voltage, Relative to CLP	DCIN-CLP = 0.1V, $I_{\text{INFET}} = 1\mu\text{A}$		-6.5		-5	V
$V_{\text{OH(INFET)}}$	INFET Output High Voltage, Relative to CLP	DCIN-CLP = -0.1V, $I_{\text{INFET}} = -5\mu\text{A}$		-250		250	mV
$t_{\text{F(ON)}}$	INFET Turn-On Time	$T_{\text{O CLP-INFET}} > 3\text{V}$, $C_{\text{INFET}} = 1\text{nF}$			85	180	μs
$t_{\text{F(OFF)}}$	INFET Turn-Off Time	$T_{\text{O CLP-INFET}} < 1.5\text{V}$, $C_{\text{INFET}} = 1\text{nF}$			2.5	6	μs
Float Voltage Select Inputs (LTC4012-1/LTC4012-2 Only)							
V_{IL}	Input Voltage Low					0.5	V
V_{IH}	Input Voltage High			3.5			V
I_{IN}	Input Current	$0\text{V} \leq V_{\text{IN}} \leq 5\text{V}$		-10		10	μA
Indicator Outputs							
V_{OL}	Output Voltage Low	$I_{\text{LOAD}} = 100\mu\text{A}$, PROG = 1.2V				500	mV
I_{LEAK}	Output Leakage	SHDN = 0V, DCDIV = 0V, $V_{\text{OUT}} = 20\text{V}$	●	-10		10	μA
I_{C10}	CHRG C/10 Current Sink	CHRG = 2.5V	●	15	25	38	μA

4012fa

ELECTRICAL CHARACTERISTICS

Note 1: Stresses beyond those listed under Absolute Maximum Ratings may cause permanent damage to the device. Exposure to any Absolute Maximum Rating condition for extended periods may affect device reliability and lifetime.

Note 2: The LTC4012C is guaranteed to meet performance specifications over the 0°C to 85°C operating temperature range. The LTC4012I is guaranteed to meet performance specifications over the -40°C to 125°C operating temperature range.

Note 3: Operating junction temperature T_J (in °C) is calculated from the ambient temperature T_A and the total continuous package power dissipation P_D (in watts) by the formula $T_J = T_A + (\theta_{JA} \cdot P_D)$. Refer to the Applications Information section for details.

Note 4: All currents into device pins are positive; all currents out of device pins are negative. All voltages are referenced to GND, unless otherwise specified.

Note 5: Output current may be limited by internal power dissipation. Refer to the Applications Information section for details.

TEST CIRCUITS

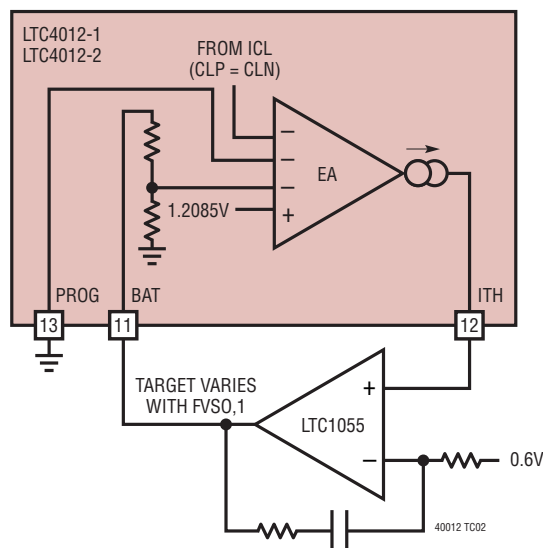
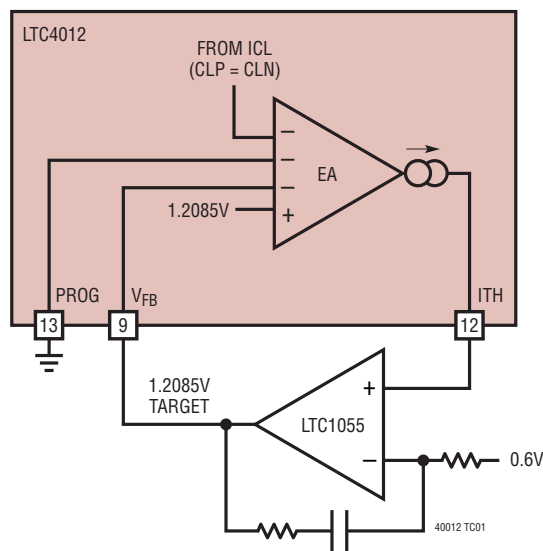

TYPICAL PERFORMANCE CHARACTERISTICS

($T_A = 25^\circ\text{C}$ unless otherwise noted. $L = \text{IHLP-2525 } 6.8\mu\text{H}$)

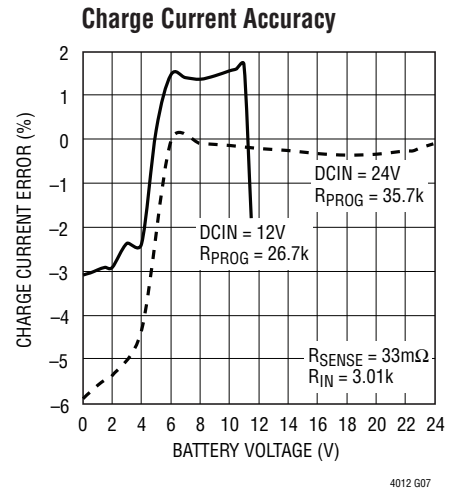
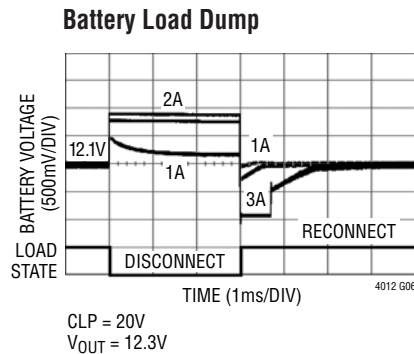
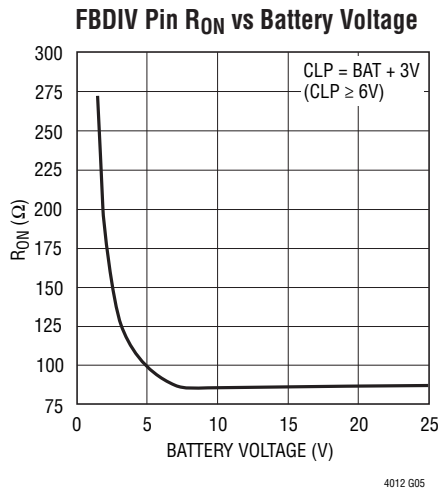
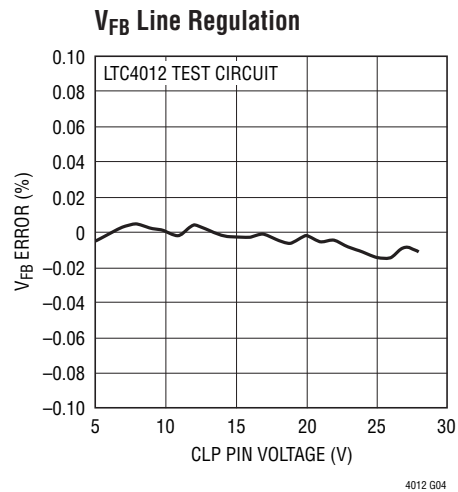
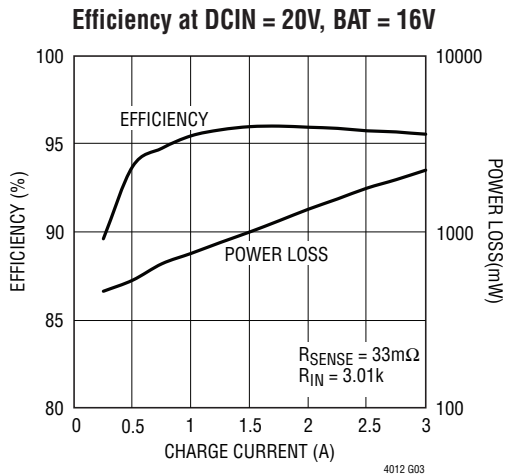
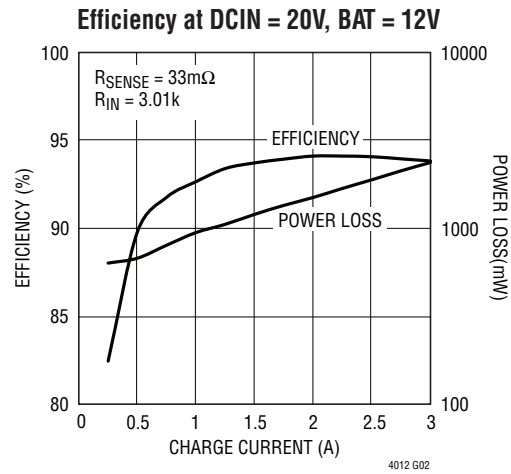
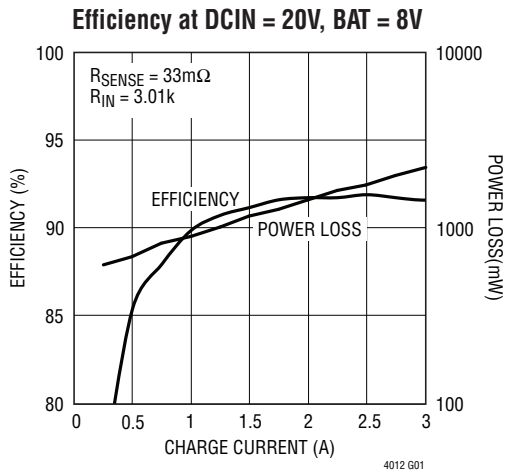

TYPICAL PERFORMANCE CHARACTERISTICS

($T_A = 25^\circ\text{C}$ unless otherwise noted. $L = \text{IHLP-2525 } 6.8\mu\text{H}$)

Charge Current Line Regulation

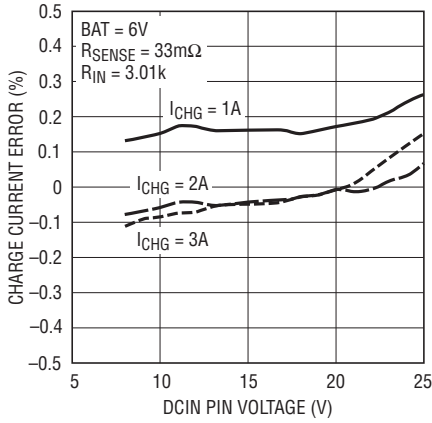

4012 G08

Charge Current Load Regulation

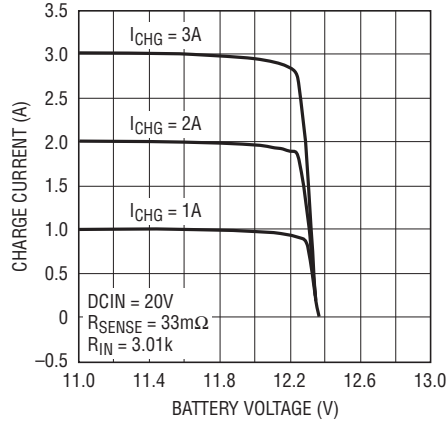

4012 G09

Input Current Limit

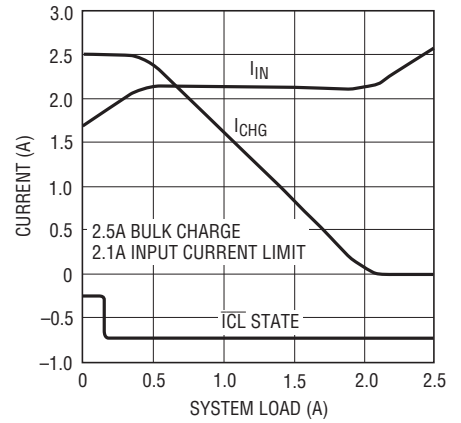

4012 G10

PWM Soft-Start

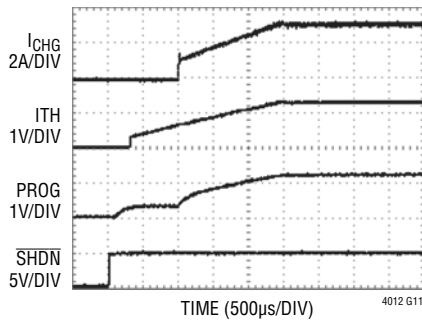

4012 G11

Gate Drive Non-Overlap

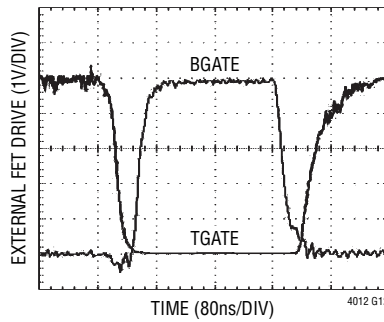

4012 G12

PWM Frequency vs Duty Cycle

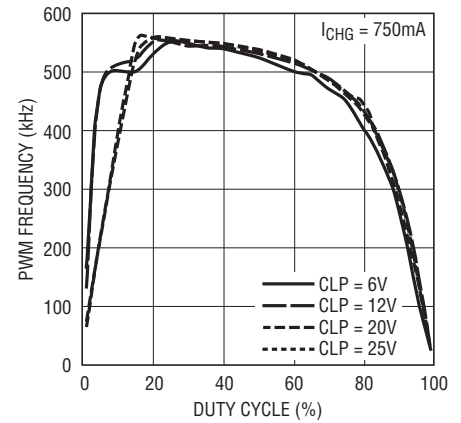

4012 G13

PWM Frequency vs Charge Current

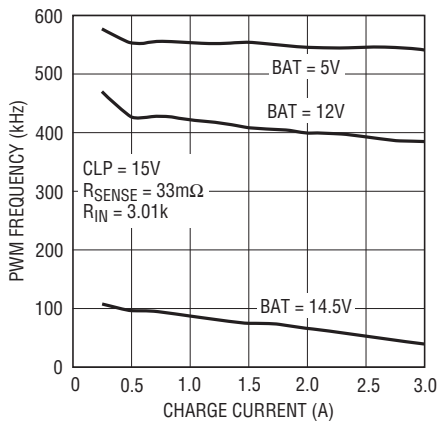

4012 G14

Battery Shutdown Current

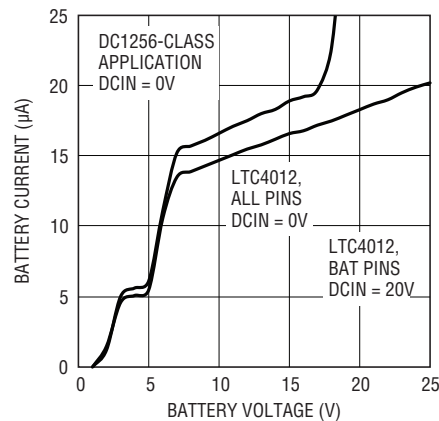

4012 G15

INFET Response Time to DCIN Short to Ground

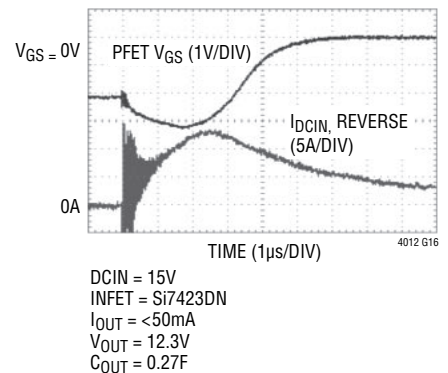

4012 G16

PIN FUNCTIONS

CLN (Pin 1): Adapter Input Current Limit Negative Input. The LTC4012 senses voltage on this pin to determine if less charge current should be sourced to limit total input current. The threshold is set 100mV below the CLP pin. An external filter should be used to remove switching noise. This input should be tied to CLP if not used. Operating voltage range is (CLP – 110mV) to CLP.

CLP (Pin 2): Adapter Input Current Limit Positive Input. The LTC4012 also draws power from this pin, including a small amount for some shutdown functions. Operating voltage range is GND to 28V.

INFET (Pin 3): PowerPath Control Output. This output drives the gate of a PMOS pass transistor connected between the DC input (DCIN) and the raw system supply rail (CLP) to maintain a forward voltage of 25mV when a DC input source is present. INFET is internally clamped about 6V below CLP. Maximum operating voltage is CLP, which is used to turn off the input PMOS transistor when the DC input is removed.

DCIN (Pin 4): DC Sense Input. One of two voltage sense inputs to the internal PowerPath controller (the other input to the controller is CLP). This input is usually supplied from an input DC power source. Operating voltage ranges from GND to 28.2V.

ACP (Pin 5): Active-Low AC Adapter Present Indicator Output. This open-drain output pulls to GND when adequate AC adapter (DCIN) voltage is present. This output should be left floating if not used.

SHDN (Pin 6): Active-low Shutdown Input. Driving SHDN below 300mV unconditionally forces the LTC4012 into the shutdown state. This input has a 40k Ω internal pulldown to GND. Operating voltage range is GND to INTV_{DD}.

CHRG (Pin 7): Active-Low Charge Indicator Output. This open-drain output provides three levels of information about charge status using a strong pull-down, 25 μ A weak pull-down or high impedance. Refer to the Operation and Applications Information sections for further details. This output should be left floating if not used.

ICL (Pin 8): Active-Low Input Current Limit Indicator Output. This open-drain output pulls to GND when the charge current is reduced because of AC adapter input current limiting. This output should be left floating if not used.

V_{FB} (Pin 9, LTC4012): Battery Voltage Feedback Input. An external resistor divider between FBDIV and GND with the center tap connected to V_{FB} programs the charger output voltage. In constant voltage mode, this pin is nominally at 1.2085V. Refer to the Applications Information section for complete details on programming battery voltage. Operating voltage range is GND to 1.25V.

FVS0 (Pin 9, LTC4012-1/LTC4012-2): Battery Voltage Select Input (LSB). This pin is one of two pins used on the LTC4012-1 or LTC4012-2 to select one of four preset battery voltages. Selection is done by connecting to either GND or INTV_{DD}. Operating voltage range is GND to INTV_{DD}.

FBDIV (Pin 10, LTC4012): Battery Voltage Feedback Resistor Divider Source. The LTC4012 connects this pin to BAT when charging is in progress. FBDIV is an open-drain PFET output to BAT with an operating voltage range of GND to BAT.

FVS1 (Pin 10, LTC4012-1/LTC4012-2): Battery Voltage Select Input (MSB). This pin is one of two pins used on the LTC4012-1 or LTC4012-2 to select one of four preset battery voltages. Selection is done by connecting to either GND or INTV_{DD}. Operating voltage range is GND to INTV_{DD}.

BAT (Pin 11): Battery Pack Connection. The LTC4012 uses the voltage on this pin to control PWM operation when charging. Operating voltage range is GND to CLN.

ITH (Pin 12): PWM Control Voltage and Compensation Node. The LTC4012 develops a voltage on this pin to control cycle-by-cycle peak inductor current. An external R-C network connected to ITH provides PWM loop compensation. Refer to the Applications Information section for further details on establishing loop stability. Operating voltage range is GND to INTV_{DD}.

PIN FUNCTIONS

PROG (Pin 13): Charge Current Programming and Monitoring Pin. An external resistance connected between PROG and GND, along with the current sense and PWM input resistors, programs the maximum charge current. The voltage on this pin can also provide a linearized indicator of charge current. Refer to the Applications Information section for complete details on current programming and monitoring. Operating voltage range is GND to $INTV_{DD}$.

CSN (Pin 14): Charge Current Sense Negative Input. Place an external input resistor (R_{IN} , Figure 1) between this pin and the negative side of the charge current sense resistor. Operating voltage ranges from $(BAT - 50mV)$ to $(BAT + 200mV)$.

CSP (Pin 15): Charge Current Sense Positive Input. Place an external input resistor (R_{IN} , Figure 1) between this pin and the positive side of the charge current sense resistor. Operating voltage ranges from $(BAT - 50mV)$ to $(BAT + 200mV)$.

BGATE (Pin 16): External Synchronous NFET Gate Control Output. This output provides gate drive to an external NMOS power transistor switch used for synchronous rectification to increase efficiency in the step-down DC/DC converter. Operating voltage is GND to $INTV_{DD}$. BGATE should be left floating if not used.

INTV_{DD} (Pin 17): Internal 5V Regulator Output. This pin provides a means of bypassing the internal 5V regulator used to power the LTC4012 PWM FET drivers. This supply shuts down when the LTC4012 shuts down. Refer to the Application Information section for details if additional power is drawn from this pin by the application circuit.

SW (Pin 18): PWM Switch Node. The LTC4012 uses the voltage on this pin as the source reference for its topside NFET (PWM switch) driver. Refer to the Applications Information section for additional PCB layout suggestions related to this critical circuit node. Operating voltage range is GND to CLN.

TGATE (Pin 19): External NFET Switch Gate Control Output. This output provides gate drive to an external NMOS power transistor switch used in the DC/DC converter. Operating voltage range is GND to $(CLN + 5V)$.

BOOST (Pin 20): TGATE Driver Supply Input. A bootstrap capacitor is returned to this pin from a charge network connected to SW and $INTV_{DD}$. Refer to the Applications Information section for complete details on circuit topology and component values. Operating voltage ranges from $(INTV_{DD} - 1V)$ to $(CLN + 5V)$.

GND (Exposed Pad Pin 21): Ground. The package paddle provides a single-point ground for the internal voltage reference and other critical LTC4012 circuits. It must be soldered to a suitable PCB copper ground pad for proper electrical operation and to obtain the specified package thermal resistance.

LTC4012/ LTC4012-1/LTC4012-2

BLOCK DIAGRAM (LTC4012)

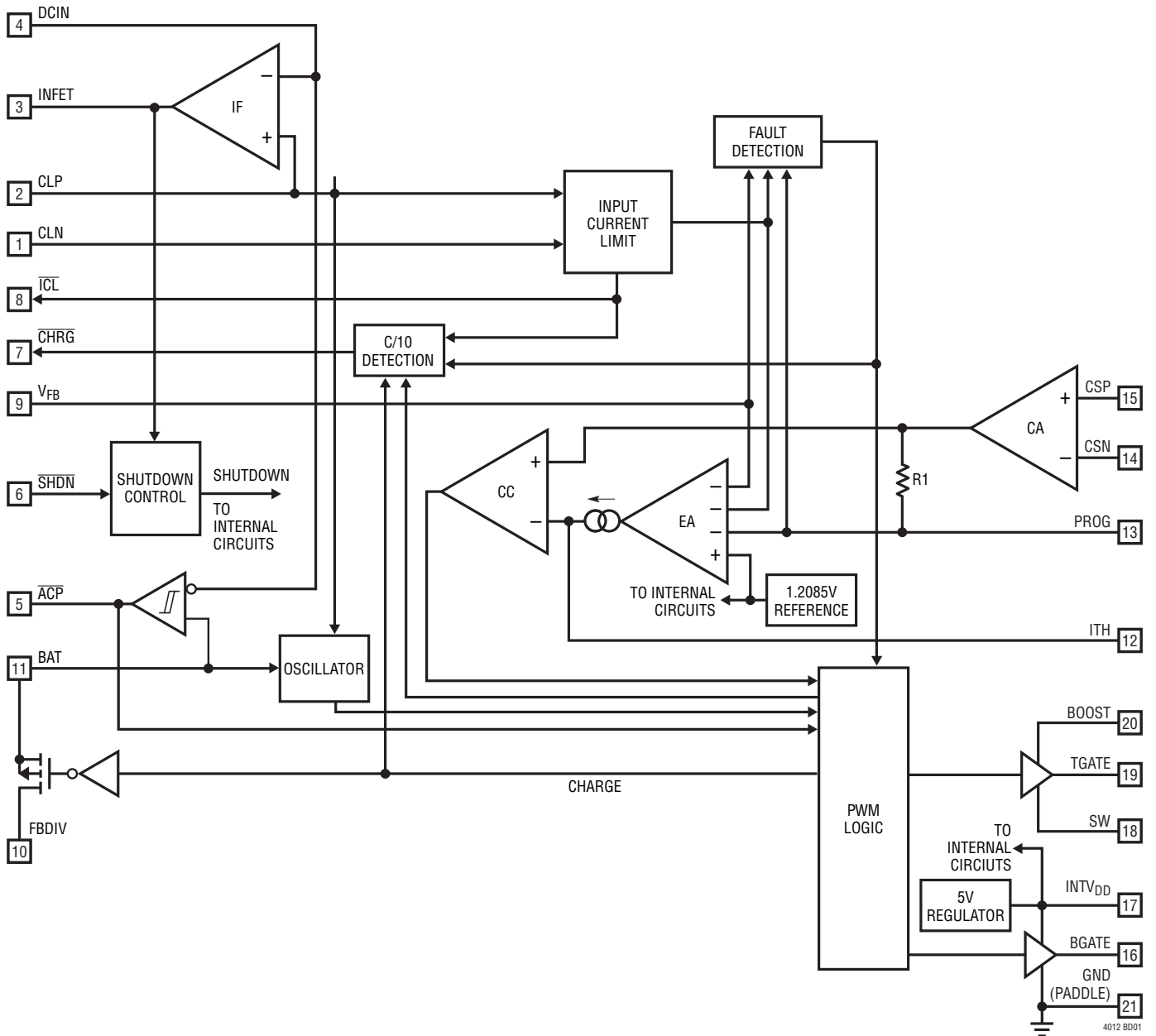

BLOCK DIAGRAM (LTC4012-1/LTC4012-2)

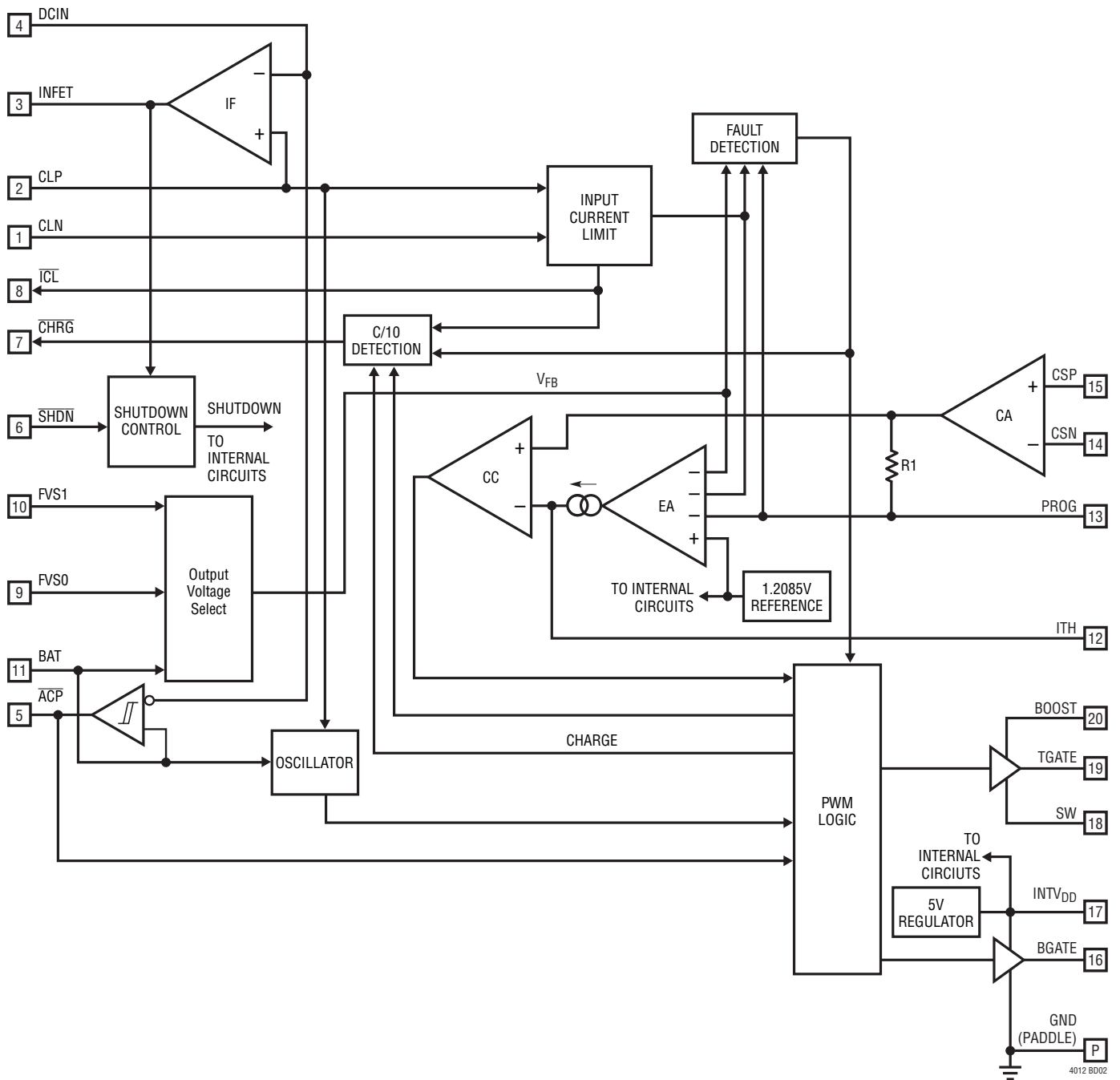

OPERATION

Overview

The LTC4012 is a synchronous step-down (buck) current mode PWM battery charger controller. The maximum charge current is programmed by the combination of a charge current sense resistor (R_{SENSE}), matched input resistors (R_{IN} , Figure 1), and a programming resistor (R_{PROG}) between the PROG and GND pins. Battery voltage is programmed with an external resistor divider between FBDIV and GND (LTC4012) or two digital battery voltage select pins (LTC4012-1/LTC4012-2). In addition, the PROG pin provides a linearized voltage output of the actual charge current.

The LTC4012 family does not have built-in charge termination and is flexible enough for charging any type of battery chemistry. These are building block ICs intended for use with an external circuit, such as a microcontroller, capable of managing the entire algorithm required for the specific battery being charged. Each member of the LTC4012 family features a shutdown input and various state indicator outputs, allowing easy and direct management by a wide range of external (digital) charge controllers. Due to the popularity of rechargeable Lithium-Ion chemistries, the LTC4012-1 and LTC4012-2 also offer internal precision resistors that can be digitally selected to produce one of four preset output voltages for simplified design of those charger types.

Shutdown

The LTC4012 remains in shutdown until DCIN is greater than 5.1V and exceeds CLP by 60mV and \overline{SHDN} is driven above 1.4V. In shutdown, current drain from the battery is reduced to the lowest possible level, thereby increasing standby time. When in shutdown, the ITH pin is pulled to GND and \overline{CHRG} , \overline{ICL} , FET gate drivers and INTV_{DD} output are all disabled. The charging can be stopped at any time by forcing \overline{SHDN} below 300mV.

AC Present Indication

The \overline{ACP} status output correctly indicates sensed adapter input voltage during all LTC4012 states. AC present is indicated (\overline{ACP} output low) as soon as DCIN exceeds BAT by at least 500mV. Charging is not enabled until this condition is first met. After this event, charging is no longer

gated by AC present detection. If battery voltage rises due to ESR, or DCIN droops due to current load, AC present may no longer be indicated by the IC if charging was started with very low input overhead. However, charging will remain enabled unless DCIN falls below the supply voltage on CLP.

Input PowerPath Control

The input PFET controller performs many important functions. First, it monitors DCIN and enables the charger when this input voltage is higher than the raw CLP system supply. Next, it controls the gate of an external input power PFET to maintain a low forward voltage drop when charging, creating improved efficiency. It also prevents reverse current flow through this same PFET, providing a suitable input blocking function. Finally, it helps avoid synchronous boost operation during invalid operating conditions by detecting elevated CLP voltage and forcing the charger off.

If DCIN voltage is less than CLP, then DCIN must rise 60mV higher than CLP to enable the charger and activate the ideal diode control. At this point, the ACPb status output also transitions to low impedance to indicate to the host system that an external adapter is present. The gate of the input PFET is driven to a voltage sufficient to regulate a forward drop between DCIN and CLP of about 25mV. If the input voltage differential drops below this point, the FET is turned off slowly. If the voltage between DCIN and CLP drops to less than -25mV, the input FET is turned off in less than 6 μ s to prevent significant reverse current from flowing back through the PFET. In this case, ACPb also switches back to high impedance and the charger is disabled.

Soft-Start

Exiting the shutdown state enables the charger and releases the ITH pin. When enabled, switching will not begin until DCIN exceeds BAT by 500mV and ITH exceeds a threshold that assures initial current will be positive (about 5% to 25% of the maximum programmed current). To limit inrush current, soft-start delay is created with the compensation values used on the ITH pin. Longer soft-start times can be realized by increasing the filter capacitor on ITH, if reduced loop bandwidth is acceptable. The actual charge current at

4012fa

OPERATION

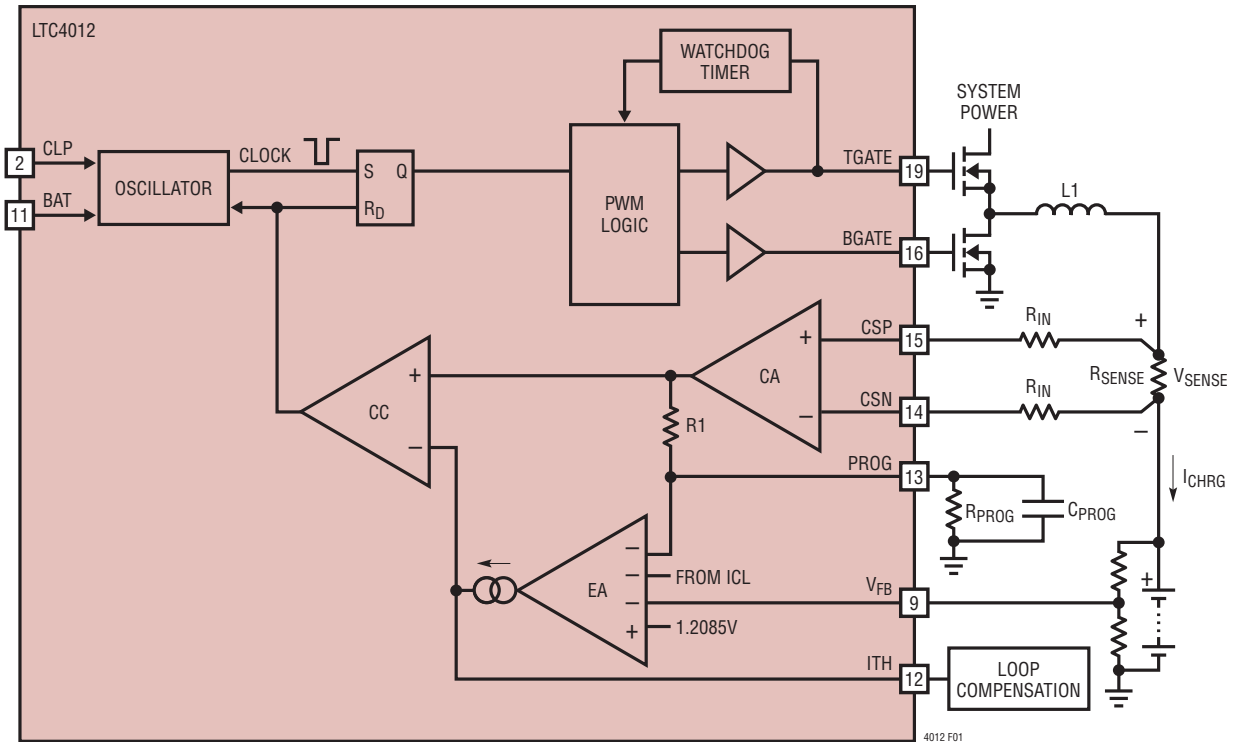

Figure 1. PWM Circuit Diagram

the end of soft-start will depend on which loop (current, voltage or adapter limit) is in control of the PWM. If this current is below that required by the ITH start-up threshold, the resulting charge current transient duration depends on loop compensation but is typically less than 100 μ s.

Bulk Charge

When soft-start is complete, the LTC4012 begins sourcing the current programmed by the external components connected to CSP, CSN and PROG. Some batteries may require a small conditioning trickle current if they are heavily discharged. As shown in the Applications Information section, the LTC4012 can address this need through a variety of low current circuit techniques on the PROG pin. Once a suitable cell voltage has been reached, charge current can be switched to a higher, bulk charge value.

End of Charge and $\overline{\text{CHRG}}$ Output

As the battery approaches the programmed output voltage, charge current will begin to decrease. The open-drain $\overline{\text{CHRG}}$ output can indicate when the current drops to 10% of its programmed full-scale value by turning off the strong

pull-down (open-drain FET) and turning on a weak 25 μ A pull-down current. This weak pull-down state is latched until the part enters shutdown or the sensed current rises to roughly C/6. C/10 indication will not be set if charge current has been reduced due to adapter input current limiting. As the charge current approaches 0A, the PWM continues to operate in full continuous mode. This avoids generation of audible noise, allowing bulk ceramic capacitors to be used in the application.

Charge Current Monitoring

When the LTC4012 is charging, the voltage on the PROG pin varies in direct proportion to the charge current. Referring to Figure 1, the nominal PROG voltage is given by

$$V_{\text{PROG}} = \frac{I_{\text{CHRG}} \cdot R_{\text{SENSE}} \cdot R_{\text{PROG}}}{R_{\text{IN}}} + 11.67\mu\text{A} \cdot R_{\text{PROG}}$$

Voltage tolerance on PROG is limited by the charge current accuracy specified in the Electrical Characteristics table. Refer to the Applications Information section on programming charge current for additional details.

OPERATION

Adapter Input Current Limit

The LTC4012 can monitor and limit current from the input DC supply, which is normally an AC adapter. When the programmed adapter input current is reached, charge current is reduced to maintain the desired maximum input current. The ITH and PROG pins will reflect the reduced charge current. This limit function avoids overloading the DC input source, allowing the product to operate at the same time the battery is charging without complex load management algorithms. The battery will automatically be charged at the maximum possible rate that the adapter will support, given the application's operating condition. The LTC4012 can only limit input current by reducing charge current, and in this case the charger uses nonsynchronous PWM operation to prevent boosting if the average charge current falls below about 25% of the maximum programmed current. Note that the \overline{ICL} indicator output becomes active (low) at an adapter input current level just slightly less than that required for the internal amplifier to begin to assert control over the PWM loop.

Charger Status Indicator Outputs

The LTC4012 open-drain indicator outputs provide valuable information about the IC's operating state and can be used for a variety of purposes in applications. Table 1 summarizes the state of the three indicator outputs as a function of LTC4012 operation.

Table 1. LTC4012 Open-Drain Indicator Outputs

ACP	CHRG	ICL	CHARGER STATE
Off	Off	Off	No DC Input (Shutdown)
On	Off	Off	Shutdown or Reverse Current
On	On	Off	Bulk Charge
On	25 μ A	Off	Low Current Charge or Initial DCIN – BAT <500mV
On	On	On	Input Current Limit During Bulk Charge
On	25 μ A	On	Input Current Limit During Low Current Charge
Off	On or 25 μ A	On or Off	Indicated Charge with DCIN - BAT < 300mV. Bulk charge may be less than programmed value.

PWM Controller

The LTC4012 uses a synchronous step-down architecture to produce high operating efficiency. The nominal operating frequency of 550kHz allows use of small filter components. The following conceptual discussion of basic PWM operation references Figure 1.

The voltage across the external charge current sense resistor R_{SENSE} is measured by current amplifier CA. This instantaneous current (V_{SENSE}/R_{IN}) is fed to the PROG pin where it is averaged by an external capacitor and converted to a voltage by the programming resistor R_{PROG} between PROG and GND. The PROG voltage becomes the average charge current input signal to error amplifier EA. EA also receives loop control information from the battery voltage feedback input V_{FB} and the adapter input current limit circuit.

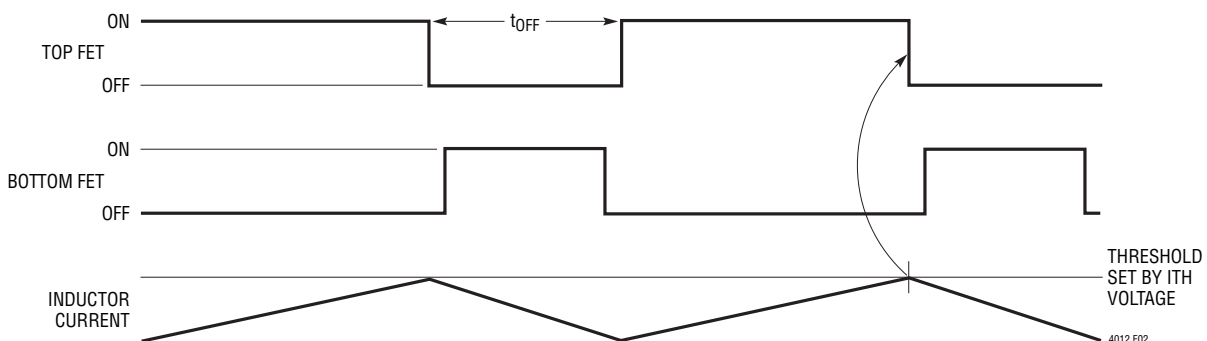

Figure 2. PWM Waveforms

OPERATION

The ITH output of the error amplifier is a scaled control voltage for one input of the PWM comparator CC. ITH sets a peak inductor current threshold, sensed by R1, to maintain the desired average current through R_{SENSE}. The current comparator output does this by switching the state of the RS latch at the appropriate time.

At the beginning of each oscillator cycle, the PWM clock sets the RS latch and turns on the external top-side NFET (bottom-side synchronous NFET off) to refresh the current carried by the external inductor L1. The inductor current and voltage across R_{SENSE} begin to rise linearly. CA buffers this instantaneous voltage rise and applies it to CC with gain supplied by R1. When the voltage across R1 exceeds the peak level set by the ITH output of EA, the top FET turns off and the bottom FET turns on. The inductor current then ramps down linearly until the next rising PWM clock edge. This closes the loop and sources the correct inductor current to maintain the desired parameter (charge current, battery voltage, or input current). To produce a near constant frequency, the PWM oscillator implements the equation:

$$t_{\text{OFF}} = \frac{\text{CLP} - \text{BAT}}{\text{CLP} \cdot 550\text{kHz}}$$

Repetitive, closed-loop waveforms for stable PWM operation appear in Figure 2.

PWM Watchdog Timer

As input and output conditions vary, the LTC4012 may need to utilize PWM duty cycles approaching 100%. In this case, operating frequency may be reduced well below 550kHz. An internal watchdog timer observes the activity on the TGATE pin. If TGATE is on for more than 40μs, the watchdog activates and forces the bottom NFET on (top NFET off)

for about 100ns. This avoids a potential source of audible noise when using ceramic input or output capacitors and prevents the boost supply capacitor for the top gate driver from discharging. In low drop out operation, the actual charge current may not be able to reach the programmed full-scale value due to the watchdog function.

Overvoltage Protection

The LTC4012 also contains overvoltage detection that prevents transient battery voltage overshoots of more than about 6% above the programmed output voltage. When battery overvoltage is detected, both external MOSFETs are turned off until the overvoltage condition clears, at which time a new soft start sequence begins. This is useful for properly charging battery packs that use an internal switch to disconnect themselves for performing functions such as calibration or pulse mode charging.

Reverse Charge Current Protection (Anti-Boost)

Because the LTC4012 always attempts to operate synchronously in full continuous mode (to avoid audible noise from ceramic capacitors), reverse average charge current can occur during some invalid operating conditions. INFET PowerPath control avoids boosting a lightly loaded system supply during reverse operation. However, under heavier system loads, CLP may not boost above DCIN, even though reverse average current is flowing. In this case a second circuit monitors indication of reverse average current on PROG.

If either of these circuits detects boost operation, The LTC4012 turns off both external MOSFETs until the reverse current condition clears. At that point, a new soft-start sequence begins.

APPLICATIONS INFORMATION

Programming Charge Current

The formula for charge current is:

$$I_{\text{CHRG}} = \frac{R_{\text{IN}}}{R_{\text{SENSE}}} \cdot \left(\frac{1.2085\text{V}}{R_{\text{PROG}}} - 11.67\mu\text{A} \right)$$

The LTC4012 operates best with 3.01k input resistors, although other resistors near this value can be used to accommodate standard sense resistor values. Refer to the subsequent discussion on inductor selection for other considerations that come into play when selecting input resistors R_{IN} .

R_{SENSE} should be chosen according to the following equation:

$$R_{\text{SENSE}} = \frac{100\text{mV}}{I_{\text{MAX}}}$$

where I_{MAX} is the desired maximum charge current I_{CHRG} . The 100mV target can be adjusted to some degree to obtain standard R_{SENSE} values and/or a desired R_{PROG} value, but target voltages lower than 100mV will cause a proportional reduction in current regulation accuracy.

The required minimum resistance between PROG and GND can be determined by applying the suggested expression for R_{SENSE} while solving the first equation given above for charge current with $I_{\text{CHRG}} = I_{\text{MAX}}$:

$$R_{\text{PROG(MIN)}} = \frac{1.2085\text{V} \cdot R_{\text{IN}}}{0.1\text{V} + 11.67\mu\text{A} \cdot R_{\text{IN}}}$$

If R_{IN} is chosen to be 3.01k with a sense voltage of 100mV, this equation indicates a minimum value for R_{PROG} of 26.9k. Table 6 gives some examples of recommended charge current programming component values based on these equations.

The resistance between PROG and GND can simply be set with a single a resistor, if only maximum charge current needs to be controlled during the desired charging algorithm.

However, some batteries require a low charge current for initial conditioning when they are heavily discharged. The charge current can then be safely switched to a higher level after conditioning is complete. Figure 3 illustrates one method of doing this with 2-level control of the PROG pin resistance. Turning Q1 off reduces the charge current to $I_{\text{MAX}}/10$ for battery conditioning. When Q1 is on, the LTC4012 is programmed to allow full I_{MAX} current for bulk charge. This technique can be expanded through the use of additional digital control inputs for an arbitrary number of pre-programmed current values.

For a truly continuous range of maximum charge current control, pulse width modulation can be used as shown in Figure 4.

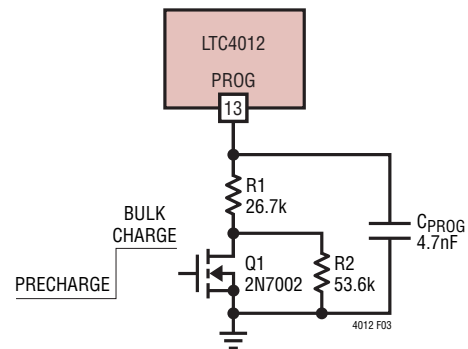

Figure 3. Programming 2-Level Charge Current

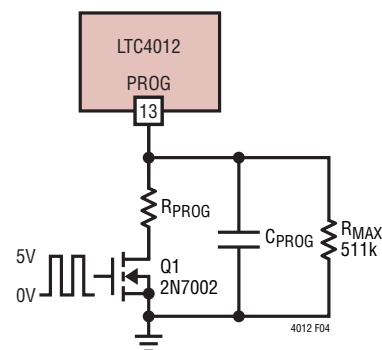

Figure 4. Programming PWM Current

APPLICATIONS INFORMATION

The value of R_{PROG} controls the maximum value of charge current which can be programmed (Q1 continuously on). PWM of the Q1 gate voltage changes the value of R_{PROG} to produce lower currents. The frequency of this modulation should be higher than a few kHz, and C_{PROG} must be increased to reduce the ripple caused by switching Q1. In addition, it may be necessary to increase loop compensation capacitance connected to ITH to maintain stability or prevent large current overshoot during start-up. Selecting a higher Q1 PWM frequency ($\approx 10\text{kHz}$) will reduce the need to change C_{PROG} or other compensation values. Charge current will be proportional to the duty cycle of the PWM input on the gate of Q1.

Programming LTC4012 Output Voltage

Figure 5 shows the external circuit for programming the charger voltage when using the LTC4012. The voltage is then governed by the following equation:

$$V_{BAT} = \frac{1.2085V \cdot (R1 + R2)}{R2}, \quad R2 = R2A + R2B$$

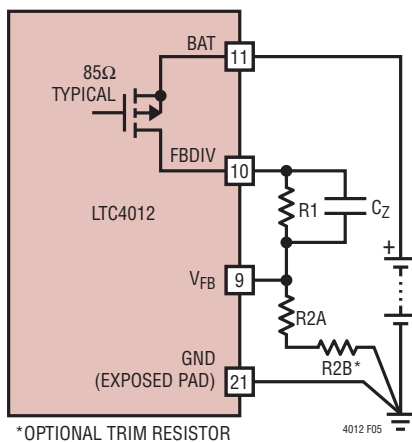

Figure 5. Programming Output Voltage

See Table 2 for approximate resistor values for R2.

$$R1 = R2 \left(\frac{V_{BAT}}{1.2085V} - 1 \right), \quad R2 = R2A + R2B$$

Selecting R2 to be less than 50k and the sum of R1 and R2 at least 200k or above, achieves the lowest possible error at the V_{FB} sense input. Note that sources of error such as R1 and R2 tolerance, FB DIV R_{ON} or V_{FB} input impedance are not included in the specifications given in the Electrical Characteristics. This leads to the possibility that very accurate (0.1%) external resistors might be required. Actually, the temperature rise of the LTC4012 will rarely exceed 50°C at the end of charge, because charge current will have tapered to a low level. This means that 0.25% resistors will normally provide the required level of overall accuracy. Table 2 gives recommended values for R1 and R2 for popular lithium-ion battery voltages. For values of R1 above 200k, addition of capacitor C_Z may improve transient response and loop stability. A value of 10pF is normally adequate.

Table 2. Programming Output Voltage

V_{BAT} (V)	R1 (0.25%) (k Ω)	R2A (0.25%) (k Ω)	R2B (1%)* (Ω)
4.1	165	69	–
4.2	167	67.3	200
8.2	162	28	–
8.4	169	28.4	–
12.3	301	32.8	–
12.6	294	31.2	–
16.4	284	22.6	–
16.8	271	21	–
20.5	316	19.8	–
21	298	18.2	–
24.6	298	15.4	–
25.2	397	20	–

*To Obtain Desired Accuracy Requires Series Resistors For R2.

APPLICATIONS INFORMATION

Programming LTC4012-1/LTC4012-2 Output Voltage

The LTC4012-1/LTC4012-2 feature precision internal battery voltage feedback resistor taps configured for common lithium-ion voltages. All that is required to program the desired voltage is proper pin programming of FVS0 and FVS1 as shown in Table 3.

Table 3. LTC4012-1/LTC4012-2 Output Voltage Programming

V _{BAT} VOLTAGE		FVS1	FVS0
LTC4012-1	LTC4012-2		
4.1V	4.2V	GND	GND
8.2V	8.4V	GND	INTV _{DD}
12.3V	12.6V	INTV _{DD}	GND
16.4V	16.8V	INTV _{DD}	INTV _{DD}

Programming Input Current Limit

To set the input current limit I_{LIM} , the minimum wall adapter current rating must be known. To account for the tolerance of the LTC4012 input current sense circuit, 5% should be subtracted from the adapter's minimum rated output. Refer to Figure 6 and program the input current limit function with the following equation.

$$R_{CL} = \frac{100\text{mV}}{I_{LIM}}$$

where I_{LIM} is the desired maximum current draw from the DC (adapter) input, including adjustments for tolerance, if any.

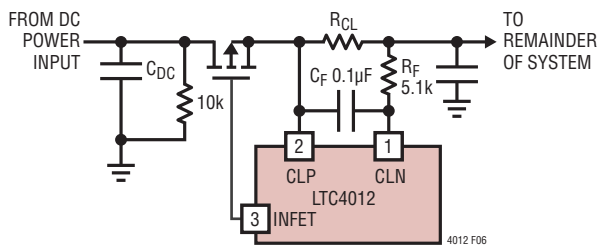

Figure 6. Programming Input Current Limit

Often an AC adapter will include a rated current output margin of at least +10%. This can allow the adapter current limit value to simply be programmed to the actual minimum rated adapter output current. Table 4 shows some common R_{CL} current limit programming values.

A lowpass filter formed by R_F (5.1k) and C_F (0.1µF) is required to eliminate switching noise from the LTC4012 PWM and other system components. If input current limiting is not desired, CLN should be shorted to CLP while CLP remains connected to power.

Table 4. Common R_{CL} Values

ADAPTER RATING (A)	R_{CL} VALUE (1%) (Ω)	R_{CL} POWER DISSIPATION (W)	R_{CL} POWER RATING (W)
1.00	0.100	0.100	0.25
1.25	0.080	0.125	0.25
1.50	0.068	0.150	0.25
1.75	0.056	0.175	0.25
2.00	0.050	0.200	0.25
2.50	0.039	0.244	0.50
3.00	0.033	0.297	0.50
3.50	0.027	0.331	0.50
4.00	0.025	0.400	0.50

Figure 7 shows an optional circuit that can influence the parameters of the input current limit in two ways.

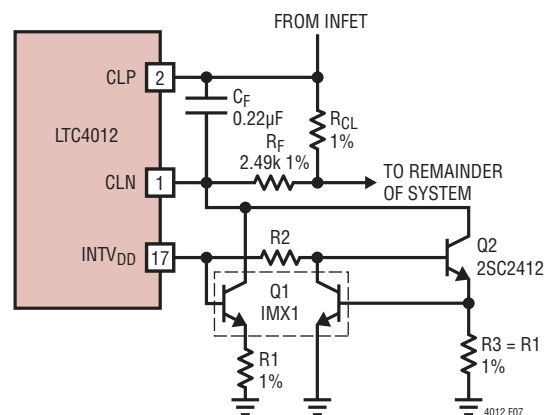

Figure 7. Adjusting Input Current Limit

APPLICATIONS INFORMATION

The first option is to lower the power dissipation of R_{CL} at the expense of accuracy without changing the input current limit value. The second is to make the input current limit value programmable.

The overall accuracy of this circuit needs to be better than the power source current tolerance or be margined such that the worse-case error remains under the power source limits.

The accuracy of the Figure 7 circuit is a function of the $INTV_{DD}$, V_{BE} , R_{CL} , R_F , R_1 and R_3 tolerances. To improve accuracy, the tolerance of R_F should be changed from 5.1k, 5% to a 2.49k 1% resistor. R_{CL} and the programming resistors R_1 and R_3 should also be 1% tolerance such that the dominant error is $INTV_{DD}$ ($\pm 3\%$). Bias resistor R_2 can be 5%. When choosing NPN transistors, both need to have good gain (>100) at $10\mu A$ levels. Low gain NPNs will increase programming errors. Q1 must be a matched NPN pair. Since R_F has been reduced in value by half, the capacitor value of C_F should double to $0.22\mu F$ to remain effective at filtering out any noise.

If you wish to reduce R_{CL} power dissipation for a given current limit, the programming equation becomes:

$$R_{CL} = \frac{100mV - \left(\frac{5 \cdot 2.49k}{R_1} \right)}{I_{LIM}}$$

If you wish to make the input current limit programmable, the equation becomes:

$$I_{LIM} = \frac{100mV - \left(\frac{5 \cdot 2.49k}{R_1} \right)}{R_{CL}}$$

The equation governing R_2 for both applications is based on the value of R_1 . R_3 should always be equal to R_1 .

$$R_2 = 0.875 \cdot R_1$$

In many notebook applications, there are situations where two different I_{LIM} values are needed to allow two different power adapters or power sources to be used. In such cases, start by setting R_{LIM} for the high power I_{LIM} configuration and then use Figure 7 to set the lower I_{LIM} value. To toggle between the two I_{LIM} values, take the three ground connections shown in Figure 7, combine them into one common connection and use a small-signal NFET (2N7002) to open or close that common connection to circuit ground. When the NFET is off, the circuit is defeated (floating) allowing I_{LIM} to be the maximum value. When the NFET is on, the circuit will become active and I_{LIM} will drop to the lower set value.

Monitoring Charge Current

The PROG pin voltage can be used to indicate charge current where 1.2085V indicates full programmed current (1C) and zero charge current is approximately equal to $R_{PROG} \cdot 11.67\mu A$. PROG voltage varies in direct proportion to the charge current between this zero-current (offset) value and 1.2085V. When monitoring the PROG pin voltage, using a buffer amplifier as shown in Figure 8 will minimize charge current errors. The buffer amplifier may be powered from the $INTV_{DD}$ pin or any supply that is always on when the charger is on.

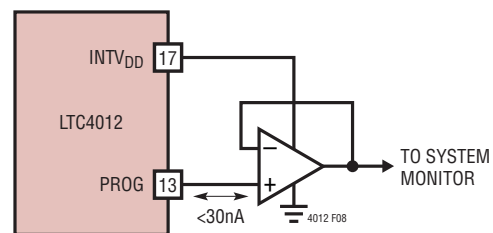

Figure 8. PROG Voltage Buffer

APPLICATIONS INFORMATION

C/10 $\overline{\text{CHRG}}$ Indicator

The value chosen for R_{PROG} has a strong influence on charge current monitoring and the accuracy of the C/10 charge indicator output ($\overline{\text{CHRG}}$). The LTC4012 uses the voltage on the PROG pin to determine when charge current has dropped to the C/10 threshold. The nominal threshold of 400mV produces an accurate low charge current indication of C/10 as long as $R_{\text{PROG}} = 26.7\text{k}$, independent of all other current programming considerations. However, it may sometimes be necessary to deviate from this value to satisfy other application design goals.

If R_{PROG} is greater than 26.7k, the actual level at which low charge current is detected will be less than C/10. The highest value of R_{PROG} that can be used while reliably indicating low charge current before reaching final V_{BAT} is 30.1k. R_{PROG} can safely be set to values higher than this, but low current indication will be lost.

If R_{PROG} is less than 26.7k, low charge current detection occurs at a level higher than C/10. More importantly, the LTC4012 becomes increasingly sensitive to reverse current. The lowest value of R_{PROG} that can be used without the risk of erroneous boost operation detection at end of charge is 26.1k. Values of R_{PROG} less than this should not be used. See the Operation section for more information about reverse current.

The nominal fractional value of I_{MAX} at which C/10 indication occurs is given by:

$$\frac{I_{\text{C10}}}{I_{\text{MAX}}} = \frac{400\text{mV} - (R_{\text{PROG}} \cdot 11.67\mu\text{A})}{1.2085\text{V} - (R_{\text{PROG}} \cdot 11.67\mu\text{A})}$$

Direct digital monitoring of C/10 indication is possible with an external application circuit like the one shown in Figure 9.

By using two different value pull-up resistors, a microprocessor can detect three states from this pin (charging, C/10 and not charging). See Figure 10. When a digital output port (OUT) from the microprocessor drives one of the resistors and a second digital input port polls the network, the charge state can be determined as shown in Table 5.

Table 5. Digital Read Back State (IN, Figure 10)

LTC4012 CHARGER STATE	OUT STATE	
	Hi-Z	1
Off	1	1
C/10 Charge	0	1
Bulk Charge	0	0

Input and Output Capacitors

In addition to typical input supply bypassing (0.1 μF) on DCIN, the relatively high ESR of aluminum electrolytic capacitors is helpful for reducing ringing when hot-plugging the charger to the AC adapter. Refer to LTC Application Note 88 for more information.

The input capacitor between system power (drain of top FET, Figure 1) and GND is required to absorb all input PWM ripple current, therefore it must have adequate ripple current rating. Maximum RMS ripple current is typically one-half of the average battery charge current. Actual capacitance value is not critical, but using the highest possible voltage rating on PWM input capacitors will minimize problems. Consult with the manufacturer before use.

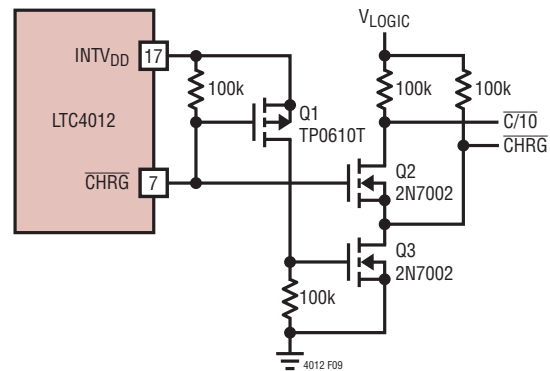

Figure 9. Digital C/10 Indicator

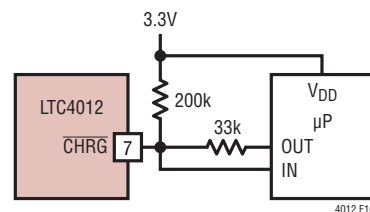

Figure 10. Microprocessor Status Interface

APPLICATIONS INFORMATION

The output capacitor shown across the battery and ground must also absorb PWM output ripple current. The general formula for this capacitor current is:

$$I_{\text{RMS}} = \frac{0.29 \cdot V_{\text{BAT}} \cdot \left(1 - \frac{V_{\text{BAT}}}{V_{\text{CLP}}}\right)}{L1 \cdot f_{\text{PWM}}}$$

For example, $I_{\text{RMS}} = 0.22\text{A}$ with:

$$V_{\text{BAT}} = 12.6\text{V}$$

$$V_{\text{CLP}} = 19\text{V}$$

$$L1 = 10\mu\text{H}$$

$$f_{\text{PWM}} = 550\text{kHz}$$

High capacity ceramic capacitors (20 μF or more) available from a variety of manufacturers can be used for input/output capacitors. Other alternatives include OS-CON and POSCAP capacitors from Sanyo.

Low ESR solid tantalum capacitors have high ripple current rating in a relatively small surface mount package, but exercise caution when using tantalum for input or output bulk capacitors. High input surge current can be created when the adapter is hot-plugged to the charger or when a battery is connected to the charger. Solid tantalum capacitors have a known failure mechanism when subjected to very high surge currents. Select tantalum capacitors that have high surge current ratings or have been surge tested.

EMI considerations usually make it desirable to minimize ripple current in battery leads. Adding Ferrite beads or inductors can increase battery impedance at the nominal 550kHz switching frequency. Switching ripple current splits between the battery and the output capacitor in inverse relation to capacitor ESR and the battery impedance. If the ESR of the output capacitor is 0.2 Ω and the battery impedance is raised to 4 Ω with a ferrite bead, only 5% of the current ripple will flow to the battery.

Inductor Selection

Higher switching frequency generally results in lower efficiency because of MOSFET gate charge losses, but it allows smaller inductor and capacitor values to be used. A primary effect of the inductor value L1 is the amplitude of ripple current created. The inductor ripple current ΔI_L decreases with higher inductance and PWM operating frequency:

$$\Delta I_L = \frac{V_{\text{BAT}} \cdot \left(1 - \frac{V_{\text{BAT}}}{V_{\text{CLP}}}\right)}{L1 \cdot f_{\text{PWM}}}$$

Accepting larger values of ΔI_L allows the use of low inductance, but results in higher output voltage ripple and greater core losses. Lower charge currents generally call for larger inductor values.

The LTC4012 limits maximum instantaneous peak inductor current during every PWM cycle. To avoid unstable switch waveforms, the ripple current must satisfy:

$$\Delta I_L < 2 \cdot \left(\frac{150\text{mV}}{R_{\text{SENSE}}} - I_{\text{MAX}} \right)$$

so choose:

$$L1 > \frac{0.125 \cdot V_{\text{CLP}}}{f_{\text{PWM}} \cdot \left(\frac{150\text{mV}}{R_{\text{SENSE}}} - I_{\text{MAX}} \right)}$$

For C-grade parts, a reasonable starting point for setting ripple current is $\Delta I_L = 0.4 \cdot I_{\text{MAX}}$. For I-grade parts, use $\Delta I_L = 0.2 \cdot I_{\text{MAX}}$ **only** if the IC will actually be used to charge batteries over the wider I-grade temperature range. The voltage compliance of internal LTC4012 circuits also imposes limits on ripple current. Select R_{IN} (in Figure 1) to avoid average current errors in high ripple designs. The following equation can be used for guidance:

$$\frac{R_{\text{SENSE}} \cdot \Delta I_L}{50\mu\text{A}} \leq R_{\text{IN}} \leq \frac{R_{\text{SENSE}} \cdot \Delta I_L}{20\mu\text{A}}$$

APPLICATIONS INFORMATION

R_{IN} should not be less than 2.37k or more than 6.04k. Values of R_{IN} greater than 3.01k may cause some reduction in programmed current accuracy. Use these equations and guidelines, as represented in Table 6, to help select the correct inductor value. This table was developed for C-grade parts to maintain maximum ΔI_L near $0.6 \cdot I_{MAX}$ with f_{PWM} at 550kHz and $V_{BAT} = 0.5 \cdot V_{CLP}$ (the point of maximum ΔI_L), assuming that inductor value could also vary by 25% at I_{MAX} . For I-grade parts, reduce maximum ΔI_L to less than $0.4 \cdot I_{MAX}$, but **only** if the IC will actually be used to charge batteries over the wider I-grade temperature range. In that case, a good starting point can be found by multiplying the inductor values shown in Table 6 by a factor of 1.6 and rounding up to the nearest standard value.

Table 6. Minimum Typical Inductor Values

V_{CLP}	L1 (Typ)	I_{MAX}	R_{SENSE}	R_{IN}	R_{PROG}
<10V	$\geq 10\mu H$	1A	100m Ω	3.01k	26.7k
10V to 20V	$\geq 20\mu H$	1A	100m Ω	3.01k	26.7k
>20V	$\geq 28\mu H$	1A	100m Ω	3.01k	26.7k
<10V	$\geq 5.1\mu H$	2A	50m Ω	3.01k	26.7k
10V to 20V	$\geq 10\mu H$	2A	50m Ω	3.01k	26.7k
>20V	$\geq 14\mu H$	2A	50m Ω	3.01k	26.7k
<10V	$\geq 3.4\mu H$	3A	33m Ω	3.01k	26.7k
10V to 20V	$\geq 6.8\mu H$	3A	33m Ω	3.01k	26.7k
>20V	$\geq 9.5\mu H$	3A	33m Ω	3.01k	26.7k
<10V	$\geq 2.5\mu H$	4A	25m Ω	3.01k	26.7k
10V to 20V	$\geq 5.1\mu H$	4A	25m Ω	3.01k	26.7k
>20V	$\geq 7.1\mu H$	4A	25m Ω	3.01k	26.7k

To guarantee that a chosen inductor is optimized in any given application, use the design equations provided and perform bench evaluation in the target application, particularly at duty cycles below 20% or above 80% where PWM frequency can be much less than the nominal value of 550kHz.

TGATE BOOST Supply

Use the external components shown in Figure 11 to develop a bootstrapped BOOST supply for the TGATE FET driver. A good set of equations governing selection of the two capacitors is:

$$C1 = \frac{20 \cdot Q_G}{4.5V}, C2 = 20 \cdot C1$$

where Q_G is the rated gate charge of the top external NFET with $V_{GS} = 4.5V$. The maximum average diode current is then given by:

$$I_D = Q_G \cdot 665kHz$$

To improve efficiency by increasing V_{GS} applied to the top FET, substitute a Schottky diode with low reverse leakage for D1.

PWM jitter has been observed in some designs operating at higher V_{IN}/V_{OUT} ratios. This jitter does not substantially affect DC charge current accuracy. A series resistor with a value of 5 Ω to 20 Ω can be inserted between the cathode of D1 and the BOOST pin to remove this jitter, if present. A resistor case size of 0603 or larger is recommended to lower ESL and achieve the best results.

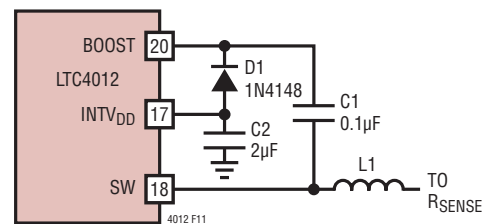

Figure 11. TGATE Boost Supply

APPLICATIONS INFORMATION

FET Selection

Two external power MOSFETs must be selected for use with the charger: an N-channel power switch (top FET) and an N-channel synchronous rectifier (bottom FET). Peak gate-to-source drive levels are internally set to about 5V. Consequently, logic-level FETs must be used. In addition to the fundamental DC current, selection criteria for these MOSFETs also include channel resistance $R_{DS(ON)}$, total gate charge Q_G , reverse transfer capacitance C_{RSS} , maximum rated drain-source voltage BV_{DSS} and switching characteristics such as $t_{d(ON/OFF)}$. Power dissipation for each external FET is given by:

$$P_{D(TOP)} = \frac{V_{BAT} \cdot I_{MAX}^2 \cdot (1 + \delta\Delta T) R_{DS(ON)}}{V_{CLP}}$$

$$+ k \cdot V_{CLP}^2 \cdot I_{MAX} \cdot C_{RSS} \cdot 665\text{kHz}$$

$$P_{D(BOT)} = \frac{(V_{CLP} - V_{BAT}) \cdot I_{MAX}^2 \cdot (1 + \delta\Delta T) R_{DS(ON)}}{V_{CLP}}$$

where δ is the temperature dependency of $R_{DS(ON)}$, ΔT is the temperature rise above the point specified in the FET data sheet for $R_{DS(ON)}$ and k is a constant inversely related to the internal LTC4012 top gate driver. The term $(1 + \delta\Delta T)$ is generally given for a MOSFET in the form of a normalized $R_{DS(ON)}$ curve versus temperature, but δ of $0.005/^\circ\text{C}$ can be used as a suitable approximation for logic-level FETs if other data is not available. $C_{RSS} = \Delta Q_{GD}/\Delta V_{DS}$ is usually specified in the MOSFET characteristics. The constant $k = 2$ can be used in estimating top FET dissipation. The LTC4012 is designed to work best with external FET switches with a total gate charge at 5V of 15nC or less.

For $V_{CLP} < 20\text{V}$, high charge current efficiency generally improves with larger FETs, while for $V_{CLP} > 20\text{V}$, top gate transition losses increase rapidly to the point that using a topline NFET with higher $R_{DS(ON)}$ but lower C_{RSS} can actually provide higher efficiency. If the charger will be operated with a duty cycle above 85%, overall efficiency is normally improved by using a larger top FET.

The synchronous (bottom) FET losses are greatest at high input voltage or during a short circuit, which forces a low side duty cycle of nearly 100%. Increasing the size of this FET lowers its losses but increases power dissipation in the LTC4012. Using asymmetrical FETs will normally achieve cost savings while allowing optimum efficiency.

Select FETs with BV_{DSS} that exceeds the maximum V_{CLP} voltage that will occur. Both FETs are subjected to this level of stress during operation. Many logic-level MOSFETs are limited to 30V or less.

The LTC4012 uses an improved adaptive TGATE and BGATE drive that is insensitive to MOSFET inertial delays, $t_{d(ON/OFF)}$, to avoid overlap conduction losses. Switching characteristics from power MOSFET data sheets apply only to a specific test fixture, so there is no substitute for bench evaluation of external FETs in the target application. In general, MOSFETs with lower inertial delays will yield higher efficiency.

Diode Selection

A Schottky diode in parallel with the bottom FET and/or top FET in an LTC4012 application clamps SW during the non-overlap times between conduction of the top and bottom FET switches. This prevents the body diode of the MOSFETs from forward biasing and storing charge, which could reduce efficiency as much as 1%. One or both diodes can be omitted if the efficiency loss can be tolerated. A 1A Schottky is generally a good size for 3A chargers due to the low duty cycle of the non-overlap times. Larger diodes can actually result in additional efficiency (transition) losses due to larger junction capacitance.

Loop Compensation and Soft-Start

The three separate PWM control loops of the LTC4012 can be compensated by a single set of components attached between the ITH pin and GND. As shown in the typical LTC4012 application, a 6.04k resistor in series with a capacitor of at least $0.1\mu\text{F}$ provides adequate loop compensation for the majority of applications.

APPLICATIONS INFORMATION

3. Place the inductor input as close as possible to the switching FETs. Minimize the surface area of the switch node. Make the trace width the minimum needed to support the programmed charge current. Use no copper fills or pours. Avoid running the connection on multiple copper layers in parallel. Minimize capacitance from the switch node to any other trace or plane.
4. Place the charge current sense resistor immediately adjacent to the inductor output, and orient it such that current sense traces to the LTC4012 are not long. These feedback traces need to be run together as a single pair with the smallest spacing possible on any given layer on which they are routed. Locate any filter component on these traces next to the LTC4012, and not at the sense resistor location.
5. Place output capacitors adjacent to the sense resistor output and ground.
6. Output capacitor ground connections must feed into the same copper that connects to the input capacitor ground before connecting back to system ground.
7. Connection of switching ground to system ground, or any internal ground plane, should be single-point. If the system has an internal system ground plane, a good way to do this is to cluster vias into a single star point to make the connection.
8. Route analog ground as a trace tied back to the LTC4012 GND paddle before connecting to any other ground. Avoid using the system ground plane. A useful CAD technique is to make analog ground a separate ground net and use a 0Ω resistor to connect analog ground to system ground.
9. A good rule of thumb for via count in a given high current path is to use 0.5A per via. Be consistent when applying this rule.
10. If possible, place all the parts listed above on the same PCB layer.
11. Copper fills or pours are good for all power connections except as noted above in Rule 3. Copper planes on multiple layers can also be used in parallel. This helps with thermal management and lowers trace inductance, which further improves EMI performance.
12. For best current programming accuracy, provide a Kelvin connection from R_{SENSE} to CSP and CSN. See Figure 13 for an example.
13. It is important to minimize parasitic capacitance on the CSP and CSN pins. The traces connecting these pins to their respective resistors should be as short as possible.

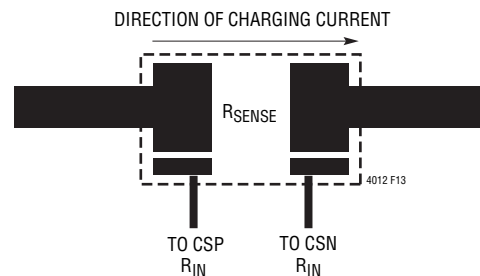
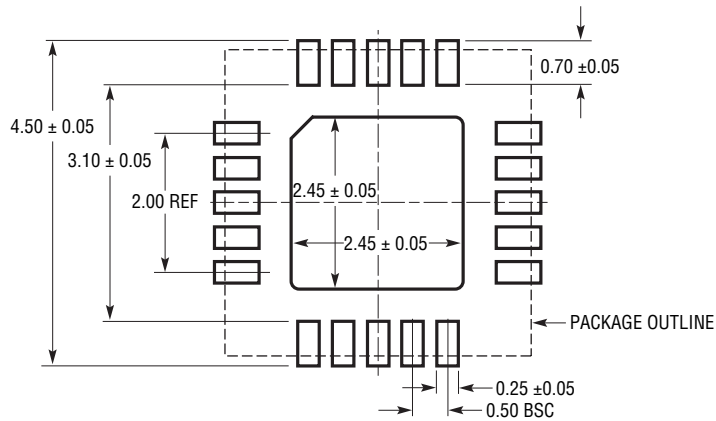

Figure 13. Kelvin Sensing of Charge Current

PACKAGE DESCRIPTION

UF Package
20-Lead Plastic QFN (4mm × 4mm)
(Reference LTC DWG # 05-08-1710 Rev A)



RECOMMENDED SOLDER PAD PITCH AND DIMENSIONS
APPLY SOLDER MASK TO AREAS THAT ARE NOT SOLDERED

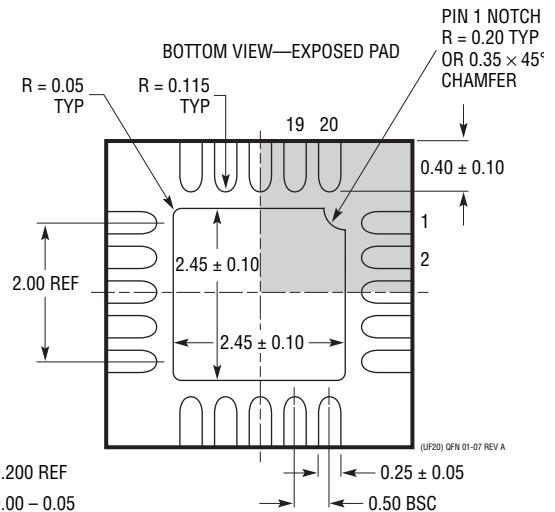
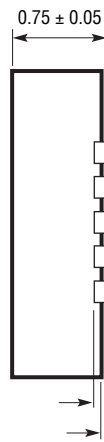
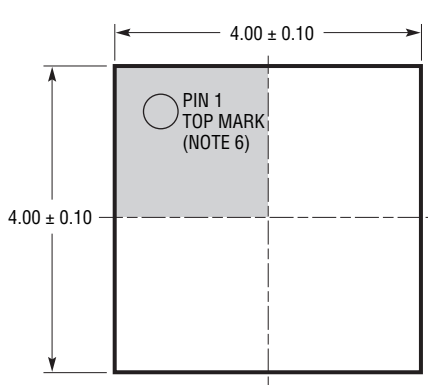

- NOTE:
1. DRAWING IS PROPOSED TO BE MADE A JEDEC PACKAGE OUTLINE MO-220 VARIATION (WGGD-1)—TO BE APPROVED
 2. DRAWING NOT TO SCALE
 3. ALL DIMENSIONS ARE IN MILLIMETERS
 4. DIMENSIONS OF EXPOSED PAD ON BOTTOM OF PACKAGE DO NOT INCLUDE MOLD FLASH. MOLD FLASH, IF PRESENT, SHALL NOT EXCEED 0.15mm ON ANY SIDE
 5. EXPOSED PAD SHALL BE SOLDER PLATED
 6. SHADED AREA IS ONLY A REFERENCE FOR PIN 1 LOCATION ON THE TOP AND BOTTOM OF PACKAGE

REVISION HISTORY

REV	DATE	DESCRIPTION	PAGE NUMBER
A	3/10	I-Grade Parts Added. Reflected Throughout the Data Sheet	1 to 28

LTC4012/ LTC4012-1/LTC4012-2

TYPICAL APPLICATION

12.6V 4 Amp Charger

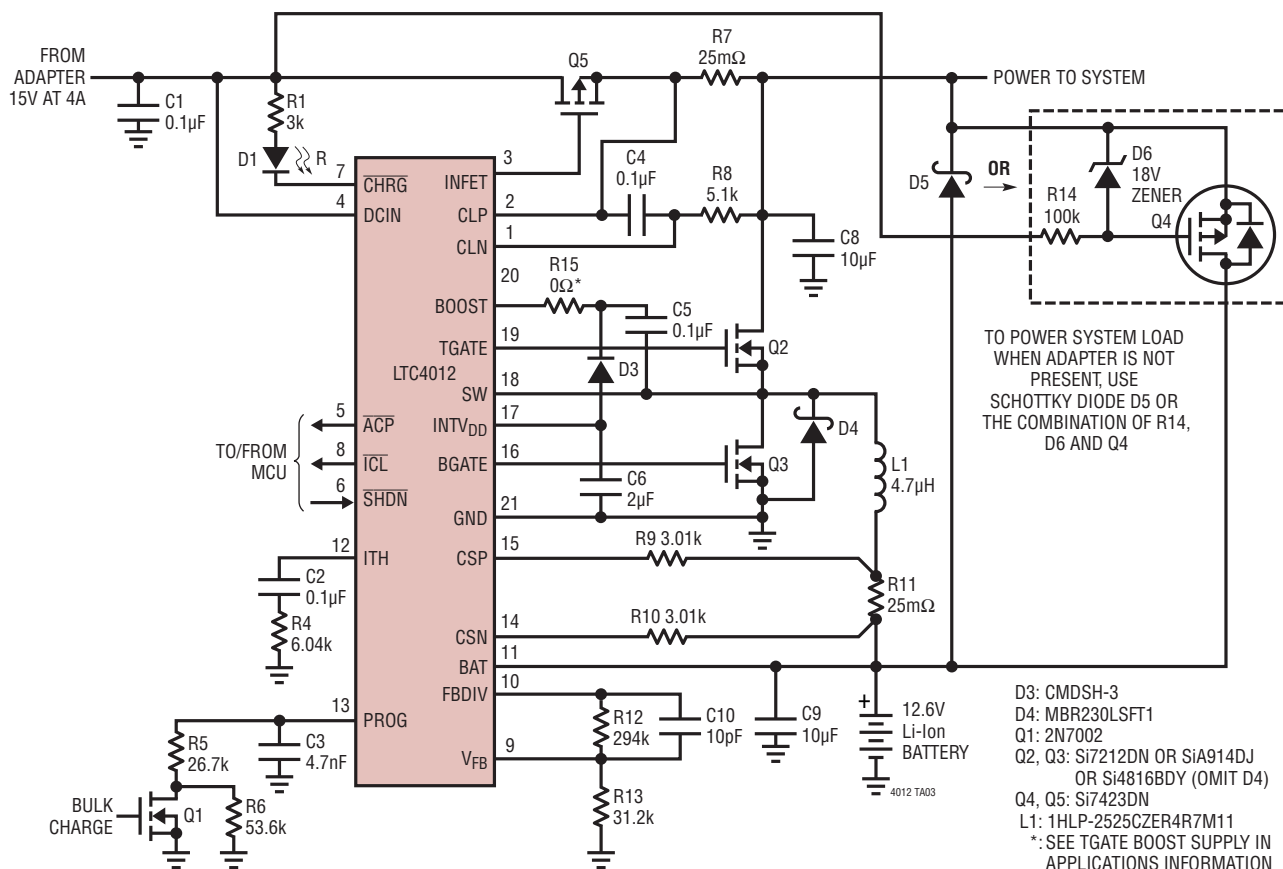

RELATED PARTS

PART NUMBER	DESCRIPTION	COMMENTS
LTC4006	Small, High Efficiency, Fixed Voltage, Lithium-Ion Battery Chargers with Termination	Complete Charger for 3- or 4-Cell Li-Ion Batteries, AC Adapter Current Limit and Thermistor Sensor, 16-pin SSOP Package
LTC4007	High Efficiency, Programmable Voltage, Lithium-Ion Battery Charger with Termination	Complete Charger for 3- or 4-Cell Li-Ion Batteries, AC Adapter Current Limit, Thermistor Sensor and Indicator Outputs
LTC4008/LTC4008-1	High Efficiency, Programmable Voltage/Current Battery Chargers	Constant-Current/Constant-Voltage Switching Regulator, Resistor Voltage/Current Programming, Thermistor Sensor and Indicator Outputs, AC Adapter Current Limit (Omitted on 4008-1)
LTC4009/LTC4009-1 LTC4009-2	High Efficiency, Multichemistry Battery Charger	Constant-Current/Constant-Voltage Switching Regulator in a 20-Lead QFN Package, AC Adapter Current Limit, Indicator Outputs
LTC4411	2.6A Low Loss Ideal Diode	No External MOSFET, Automatic Switching Between DC sources, 140mΩ On Resistance in ThinSOT™ package
LTC4412/LTC4412HV	Low Loss PowerPath Controllers	Very Low Loss Replacement for Power Supply ORing Diodes Using Minimal External Complements, Operates up to 28V (36V for HV)
LTC4413	Dual 2.6A, 2.5V to 5.5V Ideal Diodes	Low Loss Replacement for ORing Diodes, 100mΩ On Resistance
LTC4414	36V, Low Loss PowerPath Controller for Large PFETs	Low Loss Replacement for ORing Diodes, Operates up to 36V
LTC4416	Dual Low Loss PowerPath Controllers	Low Loss Replacement for ORing Diodes, Operates up to 36V, Drives Large PFETs, Programmable, Autonomous Switching

Looking for pricing, stock, or lifecycle information?

Click below to explore more details on WIN SOURCE:

 [View LTC4012IUF-2#PBF on WIN SOURCE](#)

 [Analog Devices Inc. Information](#)

Optimize Your Supply Chain with WIN SOURCE Solutions

-  Global Sourcing Solution
-  Obsolete Management
-  Cost Control Management
-  Shortage Management
-  Alternative Solution
-  Excess Inventory Management