



**THE DATASHEET OF
LTC1334CSW#TRPBF**



Single 5V RS232/RS485 Multiprotocol Transceiver

FEATURES

- Four RS232 Transceivers or Two RS485 Transceivers on One Chip
- Operates from a Single 5V Supply
- Withstands Repeated $\pm 10\text{kV}$ ESD Pulses
- Uses Small Charge Pump Capacitors: $0.1\mu\text{F}$
- Low Supply Current: 8mA Typical
- $10\mu\text{A}$ Supply Current in Shutdown
- Self-Testing Capability in Loopback Mode
- Power-Up/Down Glitch-Free Outputs
- Driver Maintains High Impedance in Three-State, Shutdown or with Power Off
- Thermal Shutdown Protection
- Receiver Inputs Can Withstand $\pm 25\text{V}$

APPLICATIONS

- Low Power RS485/RS422/RS232/EIA562 Interface
- Software-Selectable Multiprotocol Interface Port
- Cable Repeaters
- Level Translators

DESCRIPTION

The LTC[®]1334 is a low power CMOS bidirectional transceiver featuring two reconfigurable interface ports. It can be configured as two RS485 differential ports, as two dual RS232 single-ended ports or as one RS485 differential port and one dual RS232 single-ended port. An onboard charge pump requires four $0.1\mu\text{F}$ capacitors to generate boosted positive and negative supplies, allowing the RS232 drivers to meet the RS232 $\pm 5\text{V}$ output swing requirement with only a single 5V supply. A shutdown mode reduces the I_{CC} supply current to $10\mu\text{A}$.

The RS232 transceivers are in full compliance with RS232 specifications. The RS485 transceivers are in full compliance with RS485 and RS422 specifications. All interface drivers feature short-circuit and thermal shutdown protection. An enable pin allows RS485 driver outputs to be forced into high impedance, which is maintained even when the outputs are forced beyond supply rails or power is off. Both driver outputs and receiver inputs feature $\pm 10\text{kV}$ ESD protection. A loopback mode allows the driver outputs to be connected back to the receiver inputs for diagnostic self-test.

LT, LTC and LT are registered trademarks of Linear Technology Corporation.

TYPICAL APPLICATION

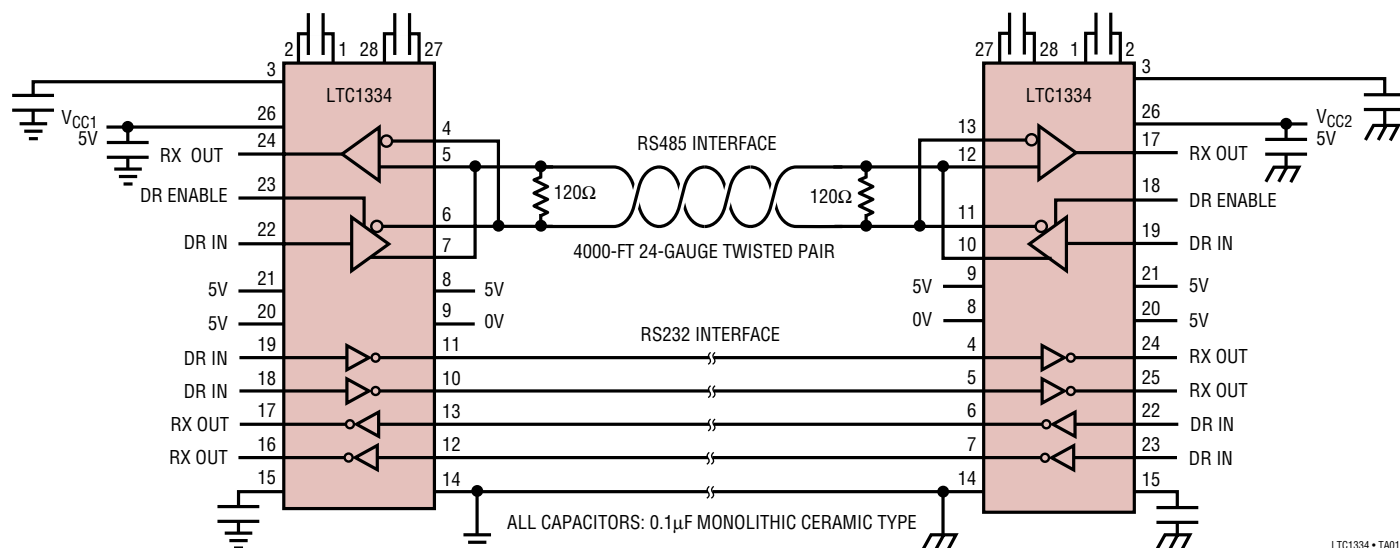

LTC1334 • TA01

ABSOLUTE MAXIMUM RATINGS

(Note 1)

Supply Voltage (V _{CC})	6.5V
Input Voltage	
Drivers	-0.3V to (V _{CC} + 0.3V)
Receivers	-25V to 25V
ON/OFF, $\overline{\text{LB}}$, SEL1, SEL2	-0.3V to (V _{CC} + 0.3V)
Output Voltage	
Drivers	-18V to 18V
Receivers	-0.3V to (V _{CC} + 0.3V)
Short-Circuit Duration	
Output	Indefinite
V _{DD} , V _{EE} , C1 ⁺ , C1 ⁻ , C2 ⁺ , C2 ⁻	30 sec
Operating Temperature Range	
Commercial	0°C to 70°C
Industrial	-40°C to 85°C
Storage Temperature Range	-65°C to 150°C
Lead Temperature (Soldering, 10 sec).....	300°C

PACKAGE/ORDER INFORMATION

TOP VIEW

G PACKAGE NW PACKAGE
 28-LEAD PLASTIC SSOP 28-LEAD PDIP WIDE

 SW PACKAGE
 28-LEAD PLASTIC SO WIDE

 T_{JMAX} = 125°C, θ_{JA} = 90°C/W (G)
 T_{JMAX} = 125°C, θ_{JA} = 56°C/W (NW)
 T_{JMAX} = 125°C, θ_{JA} = 85°C/W (SW)

ORDER PART NUMBER

LTC1334CG
LTC1334CNW
LTC1334CSW
LTC1334IG
LTC1334ISW

Consult factory for Military grade parts.

DC ELECTRICAL CHARACTERISTICS

The ● denotes specifications which apply over the full operating temperature range, otherwise specifications are at T_A = 25°C. V_{CC} = 5V, C1 = C2 = C3 = C4 = 0.1μF (Notes 2, 3)

SYMBOL	PARAMETER	CONDITIONS	MIN	TYP	MAX	UNITS
RS485 Driver (SEL1 = SEL2 = High)						
V _{OD1}	Differential Driver Output Voltage (Unloaded)	I _O = 0	●		6	V
V _{OD2}	Differential Driver Output Voltage (With Load)	Figure 1, R = 50Ω (RS422) Figure 1, R = 27Ω (RS485)	●	2.0	6	V
ΔV _{OD}	Change in Magnitude of Driver Differential Output Voltage for Complementary Output States	Figure 1, R = 27Ω or R = 50Ω	●		0.2	V
V _{OC}	Driver Common Mode Output Voltage	Figure 1, R = 27Ω or R = 50Ω	●		3	V
Δ V _{OC}	Change in Magnitude of Driver Common Mode Output Voltage for Complementary Output States	Figure 1, R = 27Ω or R = 50Ω	●		0.2	V
I _{OSD}	Driver Short-Circuit Current	-7V ≤ V _O ≤ 12V, V _O = High -7V ≤ V _O ≤ 12V, V _O = Low (Note 4)	●	35	250	mA
I _{OZD}	Three-State Output Current (Y, Z)	-7V ≤ V _O ≤ 12V	●		±5	±500 μA
RS232 Driver (SEL1 = SEL2 = Low)						
V _O	Output Voltage Swing	Figure 4, R _L = 3k, Positive Figure 4, R _L = 3k, Negative	●	5	6.5	V
I _{OSD}	Output Short-Circuit Current	V _O = 0V	●		±60	mA
Driver Inputs and Control Inputs						
V _{IH}	Input High Voltage	D, DE, ON/OFF, SEL1, SEL2, $\overline{\text{LB}}$	●	2		V
V _{IL}	Input Low Voltage	D, DE, ON/OFF, SEL1, SEL2, $\overline{\text{LB}}$	●		0.8	V
I _{IN}	Input Current	D, SEL1, SEL2 DE, ON/OFF, $\overline{\text{LB}}$	●		±10	μA
			●	-4	-15	μA

DC ELECTRICAL CHARACTERISTICS

The ● denotes specifications which apply over the full operating temperature range, otherwise specifications are at $T_A = 25^\circ\text{C}$. $V_{CC} = 5\text{V}$, $C_1 = C_2 = C_3 = C_4 = 0.1\mu\text{F}$ (Notes 2, 3)

SYMBOL	PARAMETER	CONDITIONS	MIN	TYP	MAX	UNITS	
RS485 Receiver (SEL1 = SEL2 = High)							
V_{TH}	Differential Input Threshold Voltage	$-7\text{V} \leq V_{CM} \leq 12\text{V}$, LTC1334C	●	-0.2	0.2	V	
		$-7\text{V} \leq V_{CM} \leq 7\text{V}$, LTC1334I	●	-0.3	0.3	V	
ΔV_{TH}	Input Hysteresis	$V_{CM} = 0\text{V}$		70		mV	
I_{IN}	Input Current (A, B)	$V_{IN} = -7\text{V}$	●		-0.8	mA	
		$V_{IN} = 12\text{V}$	●		1.0	mA	
R_{IN}	Input Resistance	$-7\text{V} \leq V_{IN} \leq 12\text{V}$	●	12	24	k Ω	
RS232 Receiver (SEL1 = SEL2 = Low)							
V_{TH}	Receiver Input Threshold Voltage	Input Low Threshold	●	0.8		V	
		Input High Threshold	●		2.4	V	
ΔV_{TH}	Receiver Input Hysteresis			0.6		V	
R_{IN}	Receiver Input Resistance	$V_{IN} = \pm 10\text{V}$		3	5	7	k Ω
Receiver Output							
V_{OH}	Receiver Output High Voltage	$I_O = -3\text{mA}$, $V_{IN} = 0\text{V}$, SEL1 = SEL2 = Low	●	3.5	4.6	V	
V_{OL}	Receiver Output Low Voltage	$I_O = 3\text{mA}$, $V_{IN} = 3\text{V}$, SEL1 = SEL2 = Low	●		0.2	0.4	V
I_{OSR}	Short-Circuit Current	$0\text{V} \leq V_O \leq V_{CC}$	●	7		85	mA
I_{OZR}	Three-State Output Current	ON/OFF = Low	●			± 10	μA
R_{OB}	Inactive "B" Output Pull-Up Resistance (Note 5)	ON/OFF = High, SEL1 = SEL2 = High			50		k Ω
Power Supply Generator							
V_{DD}	V_{DD} Output Voltage	No Load, ON/OFF = High		8.5		V	
		$I_{DD} = -10\text{mA}$, ON/OFF = High		7.6		V	
V_{EE}	V_{EE} Output Voltage	No Load, ON/OFF = High		-7.7		V	
		$I_{EE} = 10\text{mA}$, ON/OFF = High		-6.9		V	
Power Supply							
I_{CC}	V_{CC} Supply Current	No Load, SEL1 = SEL2 = High	●	8	25	mA	
		No Load Shutdown, ON/OFF = 0V	●	10	100	μA	

AC ELECTRICAL CHARACTERISTICS

The ● denotes specifications which apply over the full operating temperature range, otherwise specifications are at $T_A = 25^\circ\text{C}$. $V_{CC} = 5\text{V}$, $C_1 = C_2 = C_3 = C_4 = 0.1\mu\text{F}$ (Notes 2, 3)

SYMBOL	PARAMETER	CONDITIONS	MIN	TYP	MAX	UNITS	
RS232 Mode (SEL1 = SEL2 = Low)							
SR	Slew Rate	Figure 4, $R_L = 3\text{k}$, $C_L = 15\text{pF}$	●		30	V/ μs	
		Figure 4, $R_L = 3\text{k}$, $C_L = 1000\text{pF}$	●	4		V/ μs	
t_T	Transition Time	Figure 4, $R_L = 3\text{k}$, $C_L = 2500\text{pF}$	●	0.22	1.9	3.1	μs
t_{PLH}	Driver Input to Output	Figures 4, 9, $R_L = 3\text{k}$, $C_L = 15\text{pF}$	●	0.6	4	μs	
t_{PHL}	Driver Input to Output	Figures 4, 9, $R_L = 3\text{k}$, $C_L = 15\text{pF}$	●	0.6	4	μs	
t_{PLH}	Receiver Input to Output	Figures 5, 10	●	0.3	6	μs	
t_{PHL}	Receiver Input to Output	Figures 5, 10	●	0.4	6	μs	
RS485 Mode (SEL1 = SEL2 = High)							
t_{PLH}	Driver Input to Output	Figures 2, 6, $R_L = 54\Omega$, $C_L = 100\text{pF}$	●	20	40	70	ns
t_{PHL}	Driver Input to Output	Figures 2, 6, $R_L = 54\Omega$, $C_L = 100\text{pF}$	●	20	40	70	ns
t_{SKEW}	Driver Output to Output	Figures 2, 6, $R_L = 54\Omega$, $C_L = 100\text{pF}$	●	5	15		ns
t_r, t_f	Driver Rise and Fall Time	Figures 2, 6, $R_L = 54\Omega$, $C_L = 100\text{pF}$	●	3	15	40	ns

AC ELECTRICAL CHARACTERISTICS The ● denotes specifications which apply over the full operating temperature range, otherwise specifications are at $T_A = 25^\circ\text{C}$. $V_{CC} = 5\text{V}$, $C_1 = C_2 = C_3 = C_4 = 0.1\mu\text{F}$ (Notes 2, 3)

SYMBOL	PARAMETER	CONDITIONS	MIN	TYP	MAX	UNITS	
RS485 Mode (SEL1 = SEL2 = High)							
t_{ZL}	Driver Enable to Output Low	Figures 3, 7, $C_L = 100\text{pF}$, S1 Closed	●	50	90	ns	
t_{ZH}	Driver Enable to Output High	Figures 3, 7, $C_L = 100\text{pF}$, S2 Closed	●	50	90	ns	
t_{LZ}	Driver Disable from Low	Figures 3, 7, $C_L = 15\text{pF}$, S1 Closed	●	50	90	ns	
t_{HZ}	Driver Disable from High	Figures 3, 7, $C_L = 15\text{pF}$, S2 Closed	●	60	90	ns	
t_{PLH}	Receiver Input to Output	Figures 2, 8, $R_L = 54\Omega$, $C_L = 100\text{pF}$	●	20	60	140	ns
t_{PHL}	Receiver Input to Output	Figures 2, 8, $R_L = 54\Omega$, $C_L = 100\text{pF}$	●	20	70	140	ns
t_{SKEW}	Differential Receiver Skew, $ t_{PLH} - t_{PHL} $	Figures 2, 8, $R_L = 54\Omega$, $C_L = 100\text{pF}$		10		ns	

Note 1: Absolute Maximum Ratings are those values beyond which the safety of the device cannot be guaranteed.

Note 2: All currents into device pins are positive; all currents out of device pins are negative. All voltages are referenced to device ground unless otherwise specified.

Note 3: All typicals are given at $V_{CC} = 5\text{V}$, $C_1 = C_2 = C_3 = C_4 = 0.1\mu\text{F}$ and $T_A = 25^\circ\text{C}$.

Note 4: Short-circuit current for RS485 driver output low state folds back above V_{CC} . Peak current occurs around $V_O = 3\text{V}$.

Note 5: The “B” RS232 receiver output is disabled in RS485 mode (SEL1 = SEL2 = high). The unused output driver goes into a high impedance mode and has a resistor to V_{CC} . See Applications Information section for more details.

TYPICAL PERFORMANCE CHARACTERISTICS

Receiver Output High Voltage vs Temperature

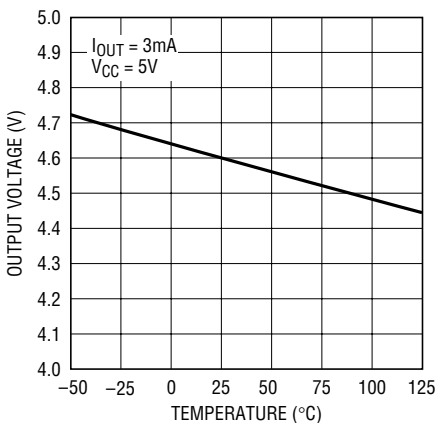

LTC1334 • TPC01

Receiver Output Low Voltage vs Temperature

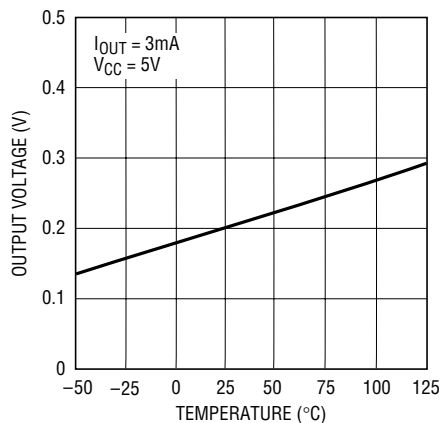

LTC1334 • TPC02

RS485 Receiver Skew $|t_{PLH} - t_{PHL}|$ vs Temperature

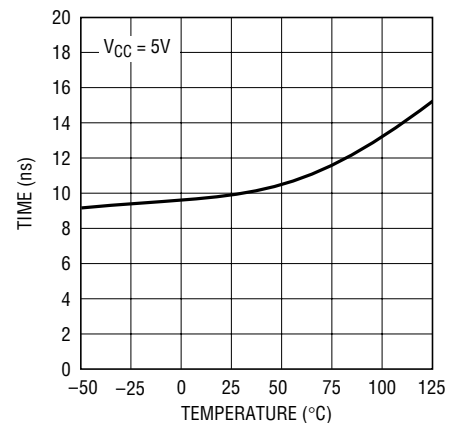

LTC1334 • TPC03

TYPICAL PERFORMANCE CHARACTERISTICS

Receiver Output Current vs Output High Voltage

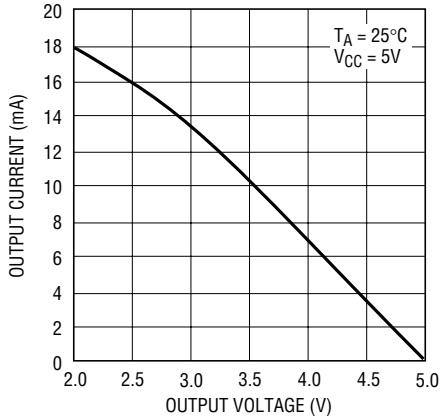

LTC1334 • TPC04

Receiver Output Current vs Output Low Voltage

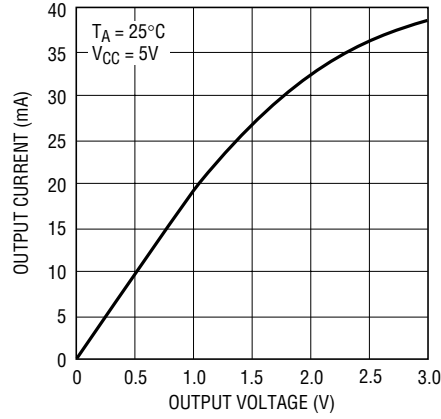

LTC1334 • TPC05

RS232 Receiver Input Threshold Voltage vs Temperature

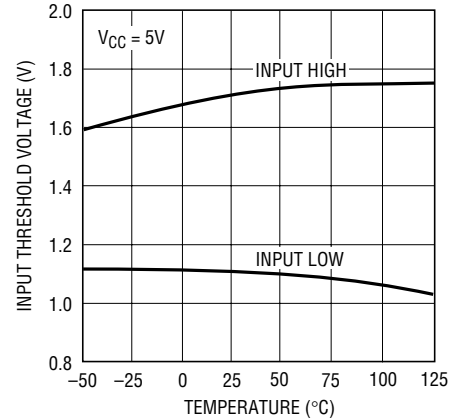

LTC1334 • TPC06

Charge Pump Output Voltage vs Temperature

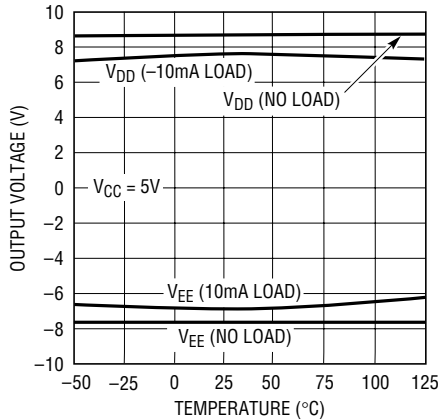

LTC1334 • TPC07

Supply Current vs Temperature (RS485)

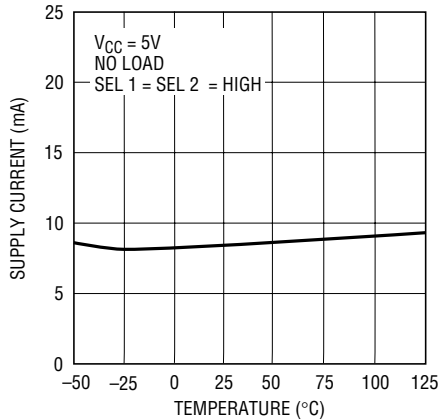

LTC1334 • TPC08

Supply Current vs Temperature (RS232)

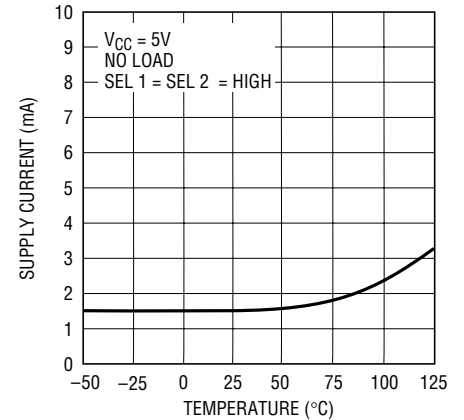

LTC1334 • TPC09

RS485 Driver Differential Output Voltage vs Temperature

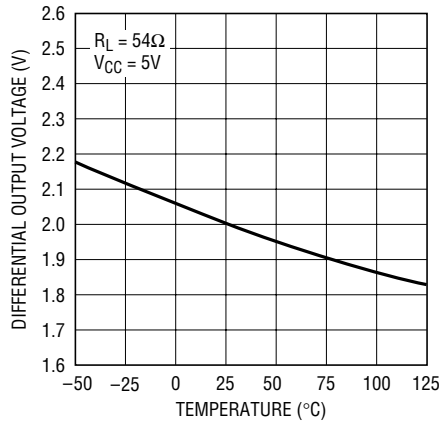

LTC1334 • TPC10

RS485 Driver Differential Output Current vs Output Voltage

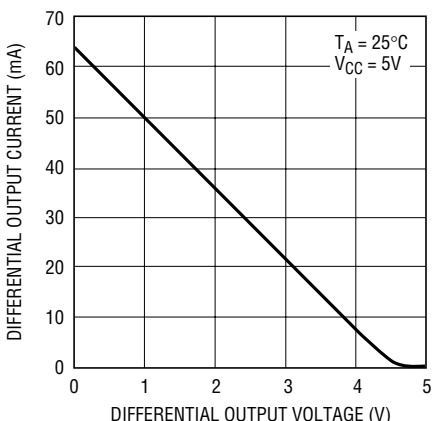

LTC1334 • TPC11

RS485 Driver Skew vs Temperature

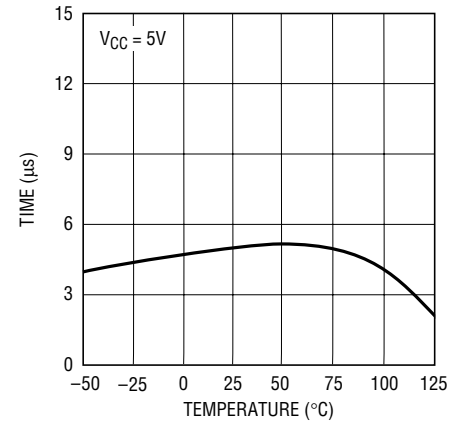

LTC1334 • TPC12

TYPICAL PERFORMANCE CHARACTERISTICS

RS485 Driver Output High Voltage vs Output Current

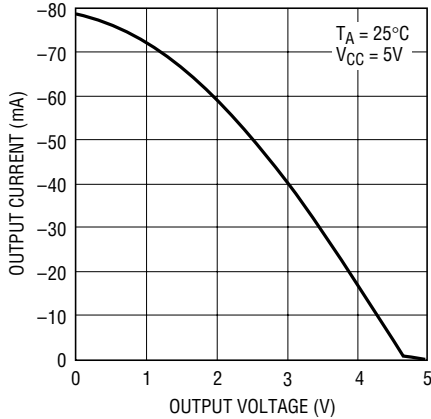

LTC1334 • TPC13

RS485 Driver Output Low Voltage vs Output Current

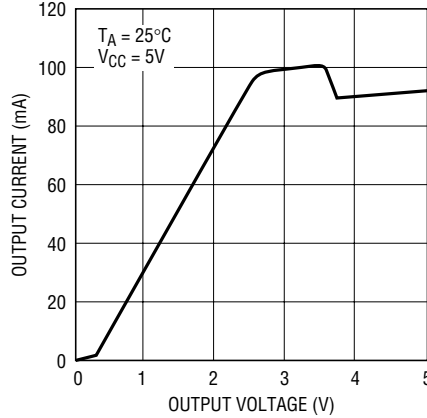

LTC1334 • TPC14

RS485 Driver Output Short-Circuit Current vs Temperature

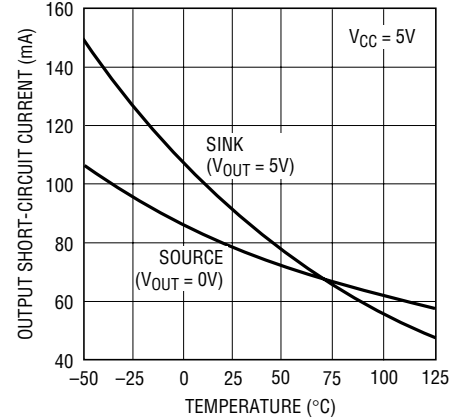

LTC1334 • TPC15

RS232 Driver Output Voltage vs Temperature

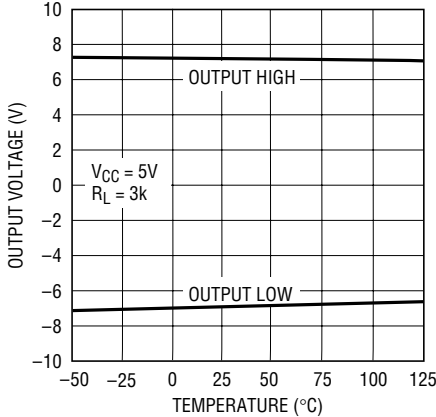

LTC1334 • TPC16

RS232 Driver Short-Circuit Current vs Temperature

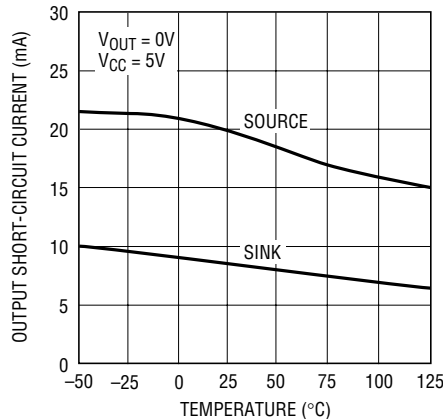

LTC1334 • TPC17

Driver Output Leakage Current (Disable/Shutdown) vs Temperature

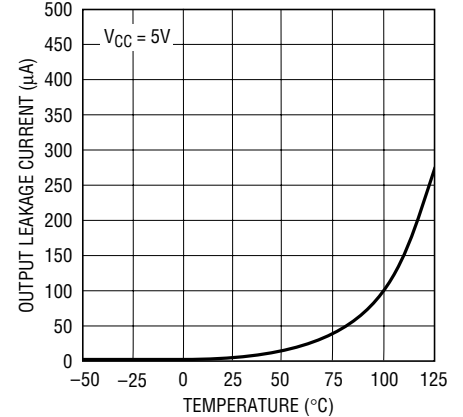

LTC1334 • TPC18

PIN FUNCTIONS

C1⁺ (Pin 1): Commutating Capacitor C1 Positive Terminal. Requires 0.1µF external capacitor between Pins 1 and 2.

C1⁻ (Pin 2): Commutating Capacitor C1 Negative Terminal.

V_{DD} (Pin 3): Positive Supply Output for RS232 Drivers. Requires an external 0.1µF capacitor to ground.

A1 (Pin 4): Receiver Input.

B1 (Pin 5): Receiver Input.

Y1 (Pin 6): Driver Output.

Z1 (Pin 7): Driver Output.

SEL1 (Pin 8): Interface Mode Select Input.

SEL2 (Pin 9): Interface Mode Select Input.

Z2 (Pin 10): Driver Output.

Y2 (Pin 11): Driver Output.

B2 (Pin 12): Receiver Input.

A2 (Pin 13): Receiver Input.

GND (Pin 14): Ground.

V_{EE} (Pin 15): Negative Supply Output. Requires an external 0.1µF capacitor to ground.

PIN FUNCTIONS

R_{B2} (Pin 16): Receiver Output.

R_{A2} (Pin 17): Receiver Output.

D_{Z2}/DE2 (Pin 18): RS232 Driver Input in RS232 Mode. RS485 Driver Enable with internal pull-up in RS485 mode.

D_{Y2} (Pin 19): Driver Input.

ON/OFF (Pin 20): A high logic input enables the transceivers. A low puts the device into shutdown mode and reduces I_{CC} to 10μA. This pin has an internal pull-up.

LB (Pin 21): Loopback Control Input. A low logic level enables internal loopback connections. This pin has an internal pull-up.

D_{Y1} (Pin 22): Driver Input.

D_{Z1}/DE1 (Pin 23): RS232 Driver Input in RS232 Mode. RS485 Driver Enable with internal pull-up in RS485 mode.

R_{A1} (Pin 24): Receiver Output.

R_{B1} (Pin 25): Receiver Output.

V_{CC} (Pin 26): Positive Supply; $4.75V \leq V_{CC} \leq 5.25V$

C2⁻ (Pin 27): Commutating Capacitor C2 Negative Terminal. Requires 0.1μF external capacitor between Pins 27 and 28.

C2⁺ (Pin 28): Commutating Capacitor C2 Positive Terminal.

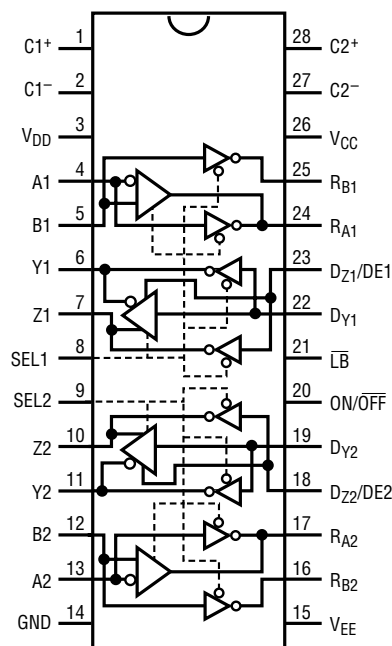

FUNCTION TABLES

RS485 Driver Mode

INPUTS				CONDITIONS	OUTPUTS	
ON/OFF	SEL	DE	D		Z	Y
1	1	1	0	No Fault	0	1
1	1	1	1	No Fault	1	0
1	1	1	X	Thermal Fault	Z	Z
1	1	0	X	X	Z	Z
0	1	X	X	X	Z	Z

RS485 Receiver Mode

INPUTS			OUTPUTS	
ON/OFF	SEL	B - A	R _A	R _B *
1	1	< -0.2V	0	1
1	1	> 0.2V	1	1
1	1	Inputs Open	1	1
0	1	X	Z	Z

*See Note 5 of Electrical Characteristics table.

RS232 Driver Mode

INPUTS			CONDITIONS	OUTPUTS
ON/OFF	SEL	D		Y, Z
1	0	0	No Fault	1
1	0	1	No Fault	0
1	0	X	Thermal Fault	Z
0	0	X	X	Z

RS232 Receiver Mode

INPUTS			OUTPUTS
ON/OFF	SEL	A, B	
1	0	0	1
1	0	1	0
1	0	Inputs Open	1
0	0	X	Z

BLOCK DIAGRAMS

Interface Configuration with Loopback Disabled

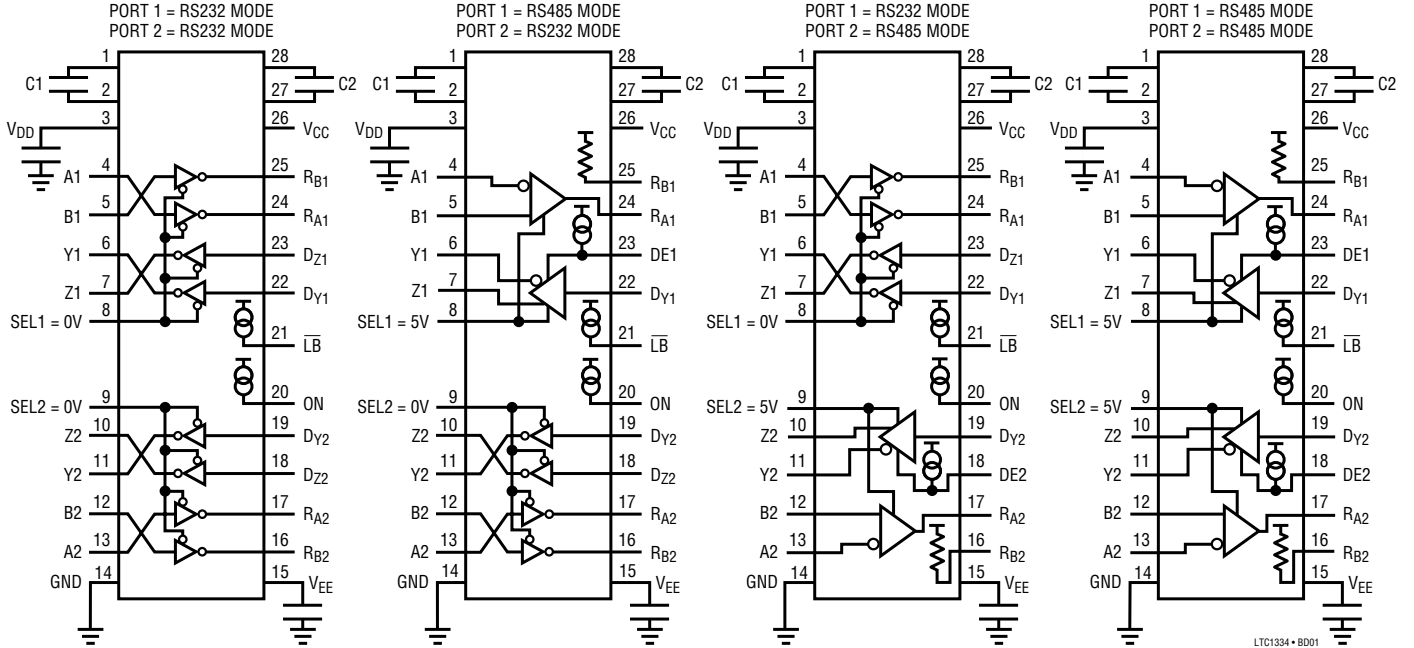

Interface Configuration with Loopback Enabled

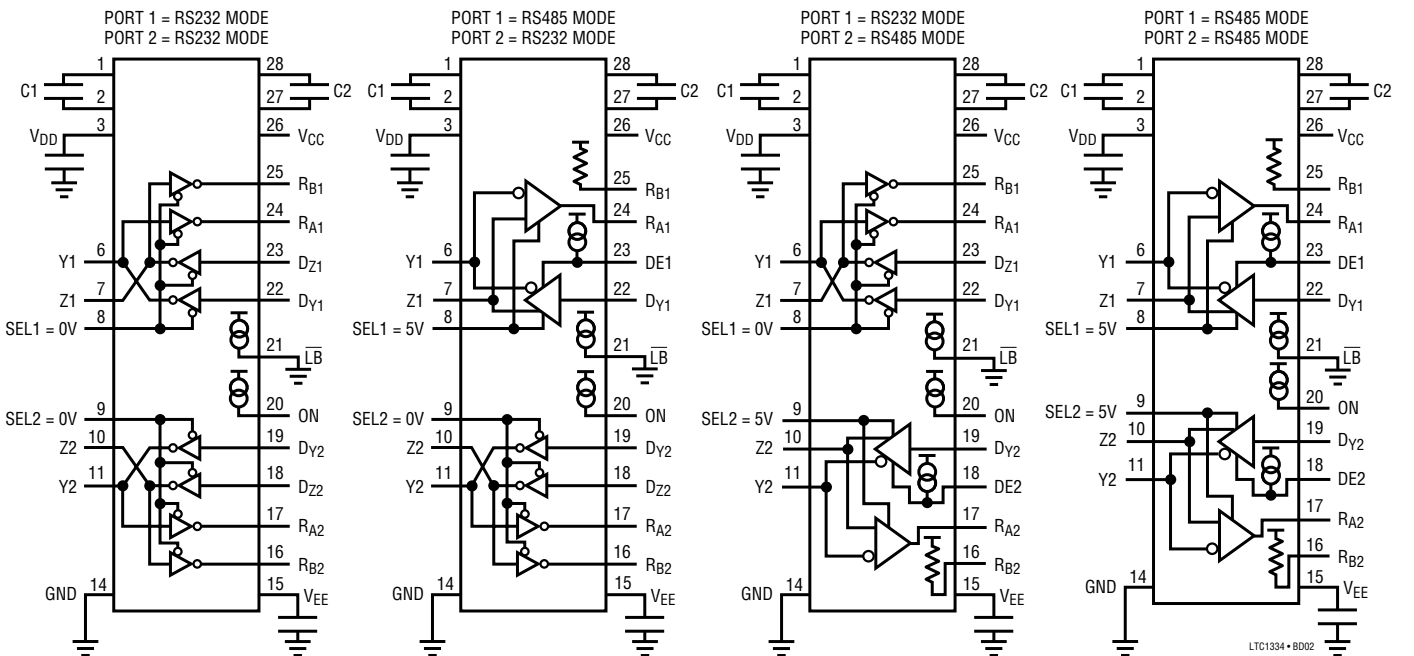

TEST CIRCUITS

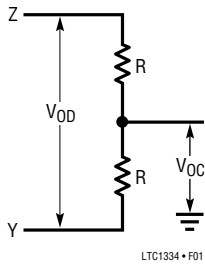

Figure 1. RS422/RS485 Driver Test Load

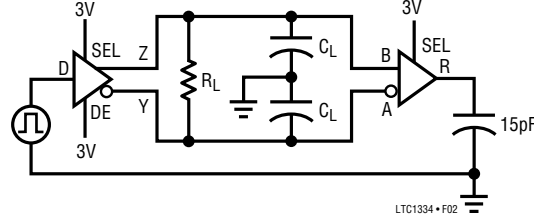

Figure 2. RS485 Driver/Receiver Timing Test Circuit

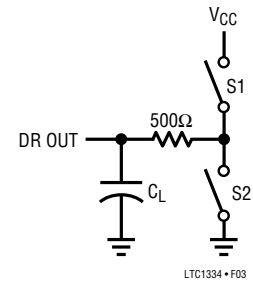

Figure 3. RS485 Driver Output Enable/Disable Timing Test Load

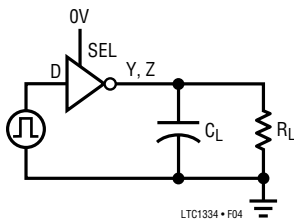

Figure 4. RS232 Driver Swing/Timing Test Circuit

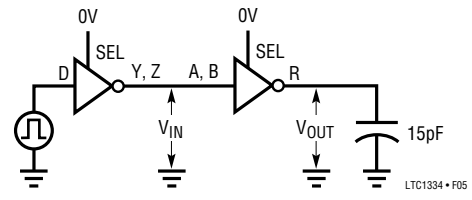

Figure 5. RS232 Receiver Timing Test Circuit

SWITCHING WAVEFORMS

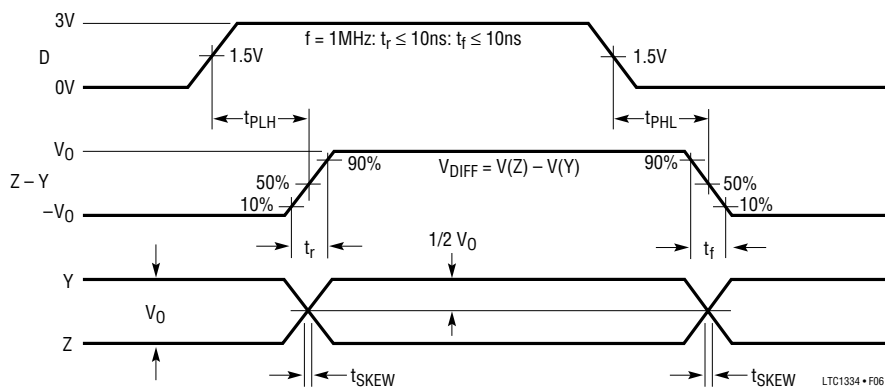

Figure 6. RS485 Driver Propagation Delays

SWITCHING WAVEFORMS

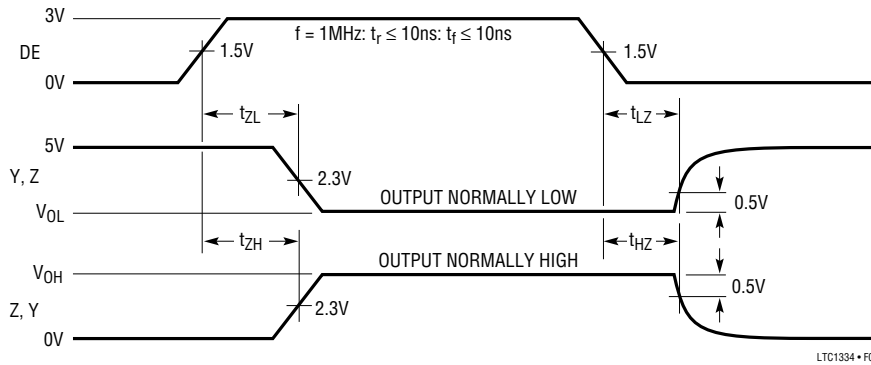

Figure 7. RS485 Driver Enable and Disable Times

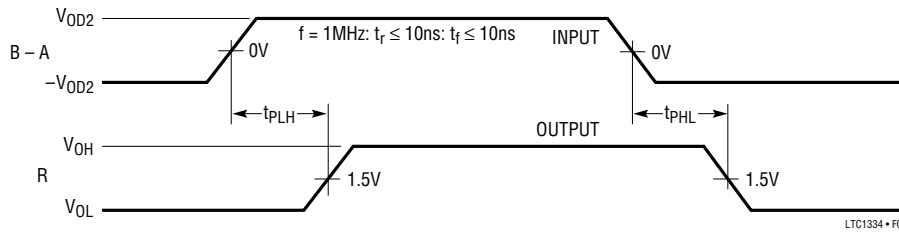

Figure 8. RS485 Receiver Propagation Delays

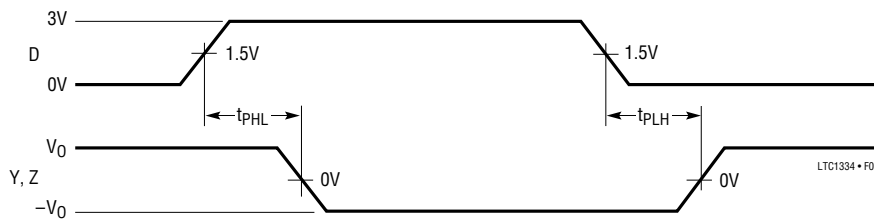

Figure 9. RS232 Driver Propagation Delays

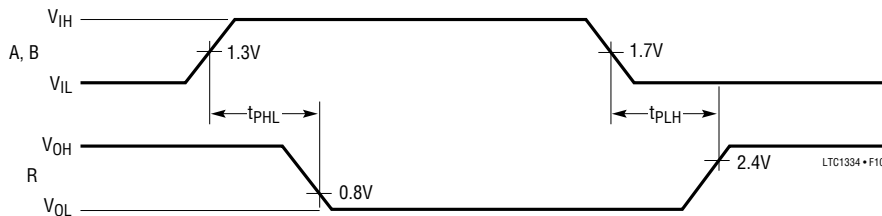

Figure 10. RS232 Receiver Propagation Delays

APPLICATIONS INFORMATION

Basic Theory of Operation

The LTC1334 has two interface ports. Each port may be configured as a pair of single-ended RS232 transceivers or as a differential RS485 transceiver by forcing the port's selection input to a low or high, respectively. The LTC1334 provides two RS232 drivers and two RS232 receivers or one RS485 driver and one RS485 receiver per port. All the interface drivers feature three-state outputs. Interface outputs are forced into high impedance when the driver is disabled, in the shutdown mode or with the power off.

All the interface driver outputs are fault-protected by a current limiting and thermal shutdown circuit. The thermal shutdown circuit disables both the RS232 and RS485 driver outputs when the die temperature reaches 150°C. The thermal shutdown circuit reenables the drivers when the die temperature cools to 130°C.

In RS485 mode, shutdown mode or with the power off, the input resistance of the receiver is 24k. The input resistance drops to 5k in RS232 mode.

A logic low at the $\overline{\text{ON/OFF}}$ pin shuts down the device and forces all the outputs into a high impedance state. A logic high enables the device. An internal 4 μA current source to V_{CC} pulls the $\overline{\text{ON/OFF}}$ pin high if it is left open.

In RS485 mode, an internal 4 μA current source pulls the driver enable pin high if left open. The RS485 receiver has a 4 μA current source at the noninverting input. If both the RS485 receiver inputs are open, the output goes to a high state. Both the current sources are disabled in the RS232 mode. The receiver output B is inactive in RS485 mode and has a 50k pull-up resistor to provide a known output state in this mode.

A loopback mode enables internal connections from driver outputs to receiver inputs for self-test when the $\overline{\text{LB}}$ pin has a low logic state. The driver outputs are not isolated from the external loads. This allows transmitter verification under the loaded condition. An internal 4 μA current source pulls the $\overline{\text{LB}}$ pin high if left open and disables the loopback configuration.

RS232/RS485 Applications

The LTC1334 can support both RS232 and RS485 levels with a single 5V supply as shown in Figure 11.

Multiprotocol Applications

The LTC1334 is well-suited for software controlled interface mode selection. Each port has a selection pin as shown in Figure 12. The single-ended transceivers support both RS232 and EIA562 levels. The differential transceivers support both RS485 and RS422.

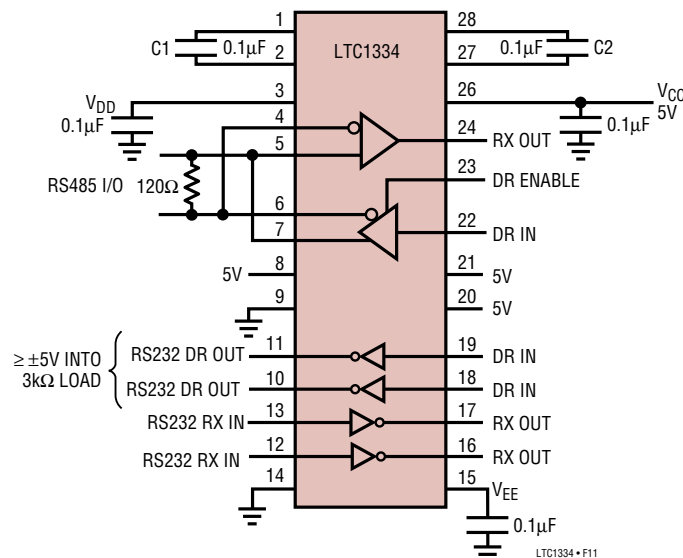

Figure 11. RS232/RS485 Interfaces

APPLICATIONS INFORMATION

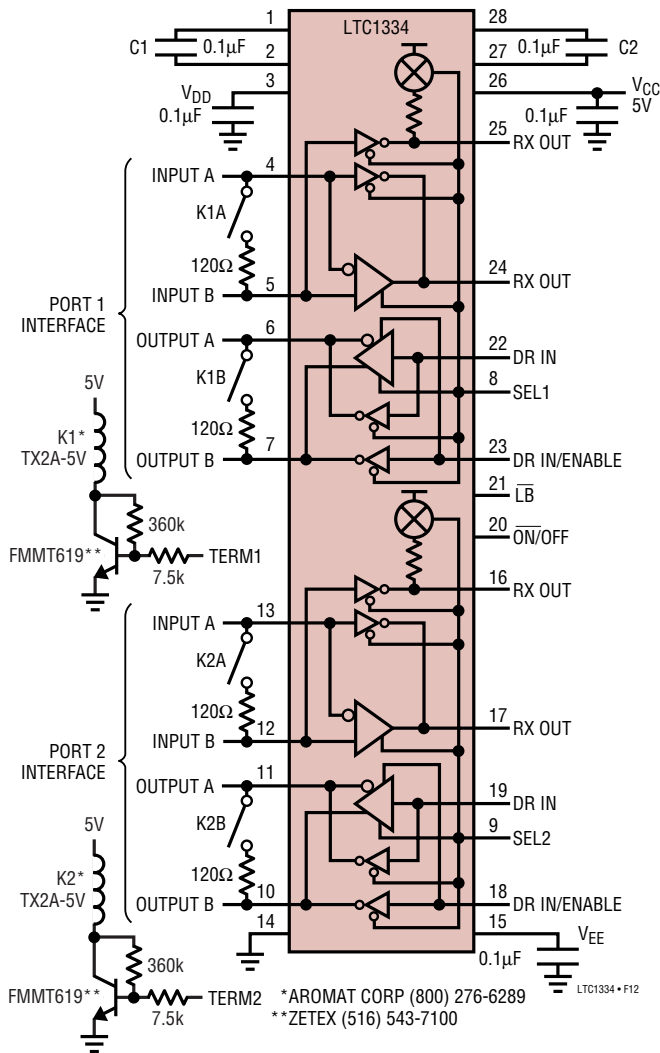

Figure 12. Multiprotocol Interface with Optional, Switchable Terminations

Each receiver in the LTC1334 is designed to present one unit load (5kΩ nominal for RS232 and 12kΩ minimum for RS485) to the cable. Some RS485 and RS422 applications call for terminations, but these are only necessary at two nodes in the system and they must be disconnected when operating in the RS232 mode. A relay is the simplest, lowest cost method of switching terminations. In Figure 12 TERM1 and TERM2 select 120Ω terminations as needed. If terminations are needed in all RS485/RS422 applications, no extra control signals are required; simply connect TERM1 and TERM2 to SEL1 and SEL2.

Typical Applications

A typical RS232/EIA562 interface application is shown in Figure 13 with the LTC1334.

A typical connection for a RS485 transceiver is shown in Figure 14. A twisted pair of wires connects up to 32 drivers and receivers for half duplex multipoint data transmission. The wires must be terminated at both ends with resistors equal to the wire's characteristic impedance. An optional shield around the twisted pair helps to reduce unwanted noise and should be connected to ground at only one end.

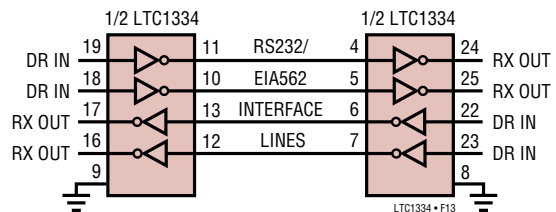

Figure 13. Typical Connection for RS232/EIA562 Interface

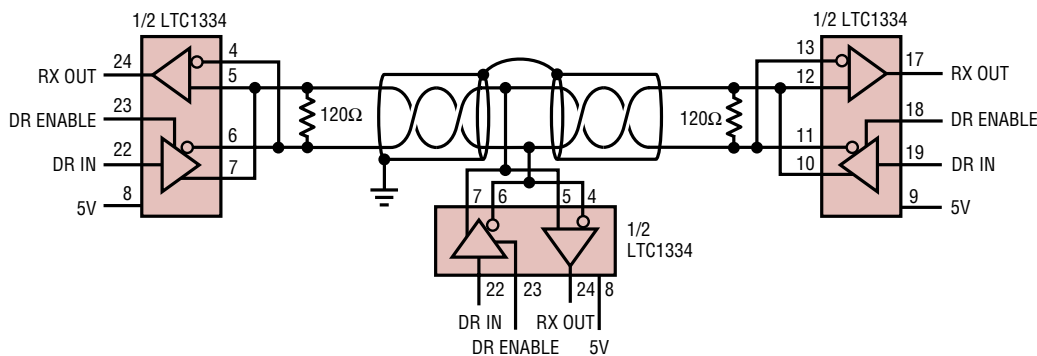

Figure 14. Typical Connection for RS485 Interface

LTC1334 F14

APPLICATIONS INFORMATION

A typical RS422 connection (Figure 15) allows one driver and ten receivers on a twisted pair of wires terminated with a 100Ω resistor at one end.

A typical twisted-pair line repeater is shown in Figure 16. As data transmission rate drops with increased cable length, repeaters can be inserted to improve transmission rate or to transmit beyond the RS422 4000-foot limit.

The LTC1334 can be used to translate RS232 to RS422 interface levels or vice versa as shown in Figure 17. One

port is configured as an RS232 transceiver and the other as an RS485 transceiver.

Using two LTC1334s as level translators, the RS232/EIA562 interface distance can be extended to 4000 feet with twisted-pair wires (Figure 18).

AppleTalk®/LocalTalk® Applications

Two AppleTalk applications are shown in Figure 19 and 20 with the LTC1323 and the LTC1334.

AppleTalk and LocalTalk are registered trademarks of Apple Computer, Inc.

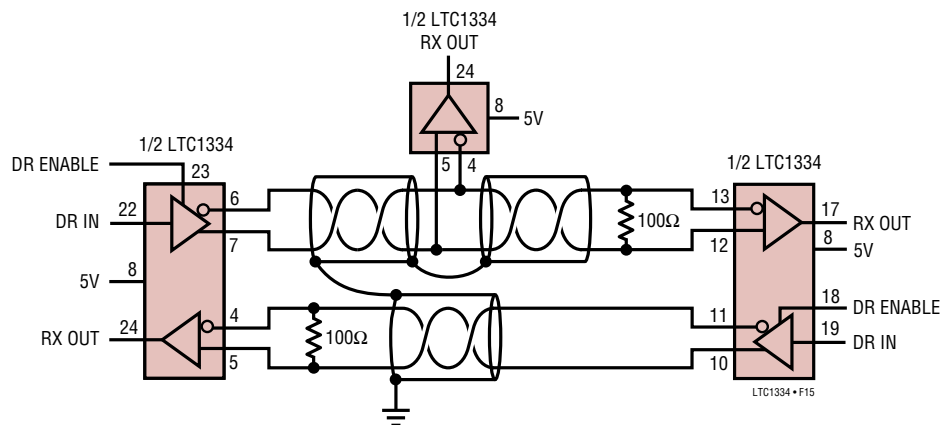

Figure 15. Typical Connection for RS422 Interface

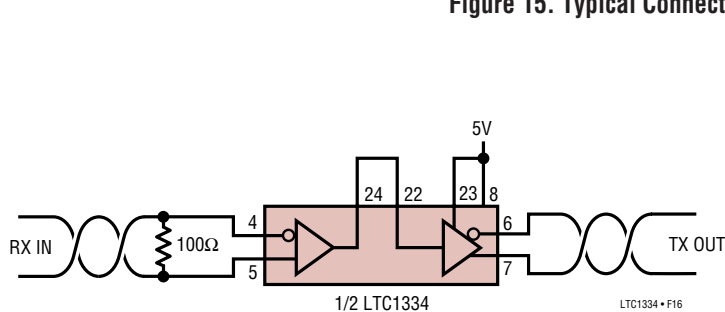

Figure 16. Typical Cable Repeater for RS422 Interface

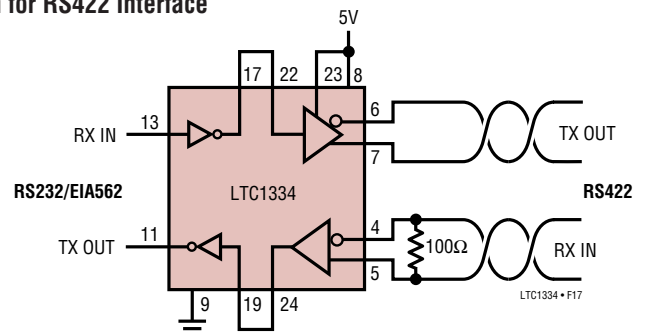

Figure 17. Typical RS232/EIA562 to RS422 Level Translator

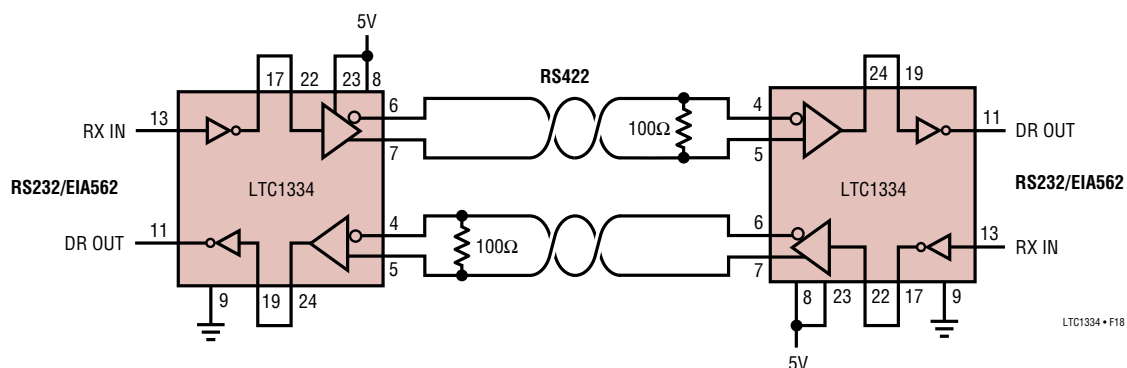

Figure 18. Typical Cable Extension for RS232/EIA562 Interface

APPLICATIONS INFORMATION

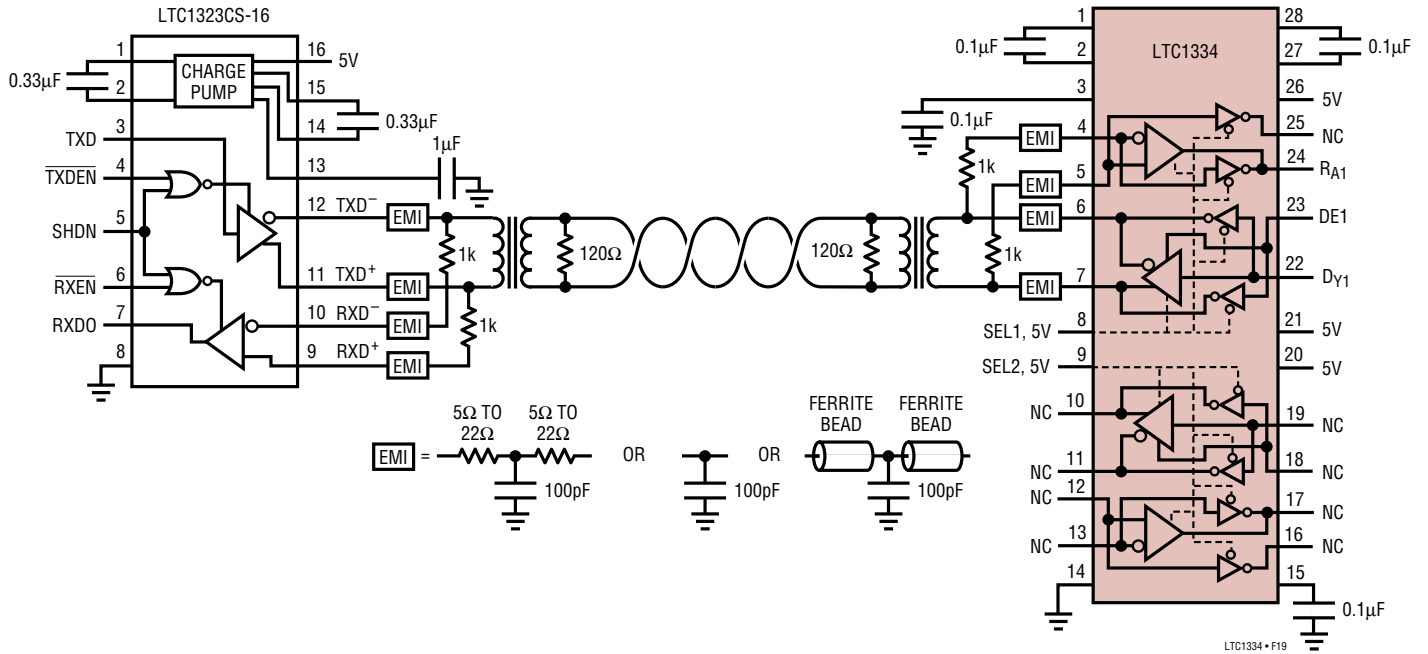

Figure 19. AppleTalk/LocalTalk Implemented Using the LTC1323CS-16 and LTC1334 Transceivers

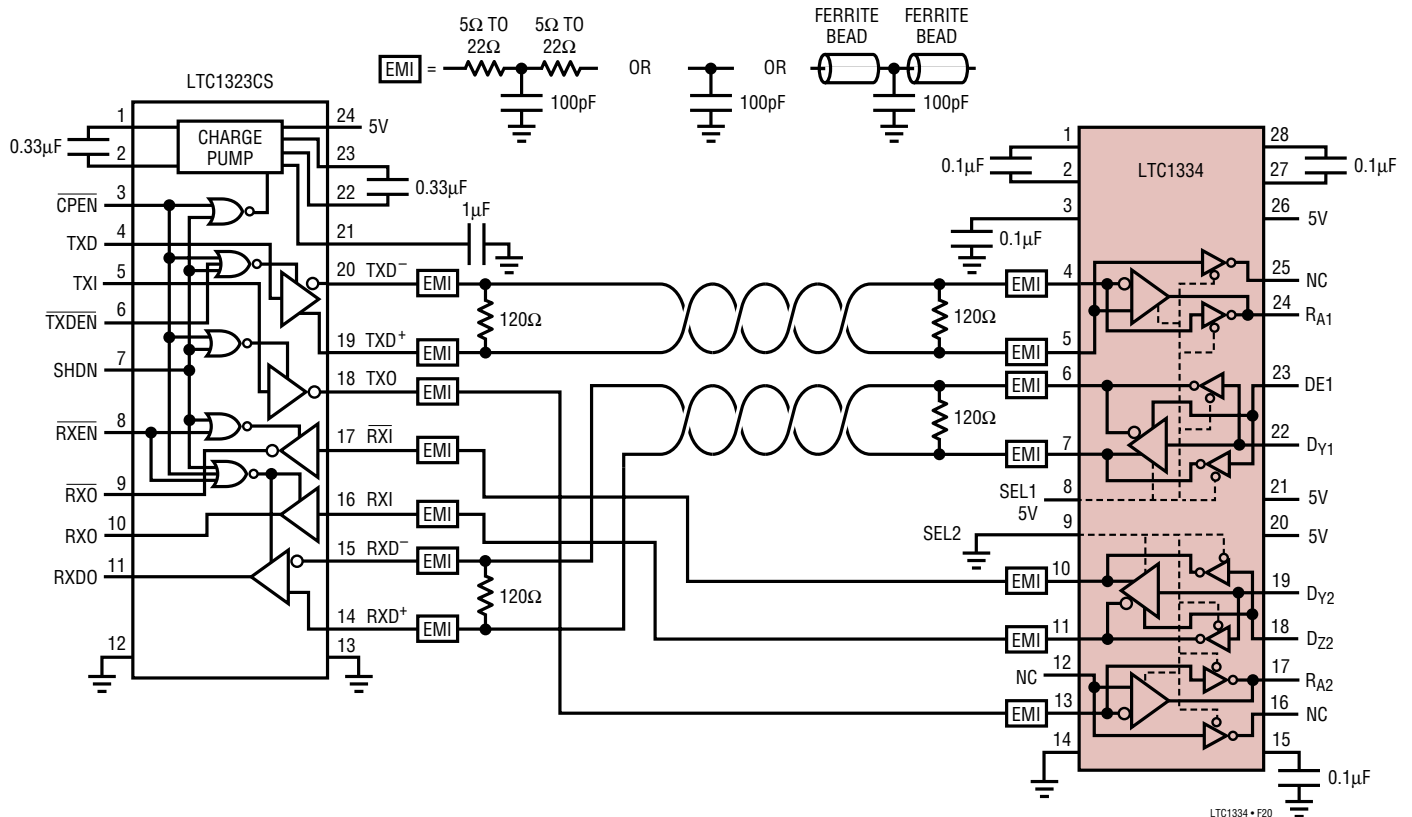
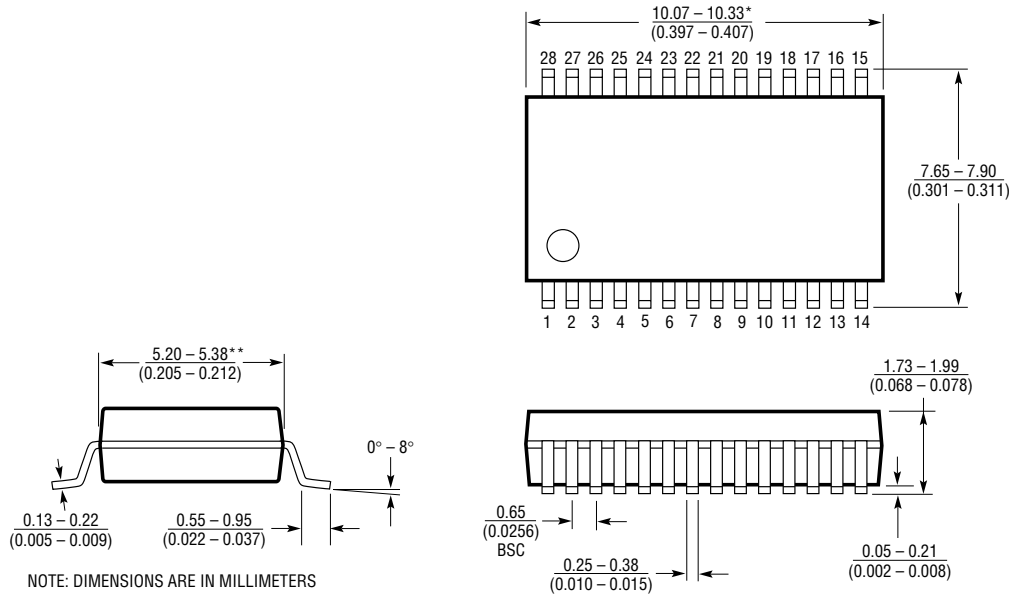

Figure 20. AppleTalk Direct Connect Using the LTC1323 DTE and the LTC1334 for DCE Transceivers

PACKAGE DESCRIPTION Dimensions in inches (millimeters) unless otherwise noted.

G Package
28-Lead Plastic SSOP (0.209)
 (LTC DWG # 05-08-1640)



NOTE: DIMENSIONS ARE IN MILLIMETERS
 *DIMENSIONS DO NOT INCLUDE MOLD FLASH. MOLD FLASH SHALL NOT EXCEED 0.152mm (0.006") PER SIDE
 **DIMENSIONS DO NOT INCLUDE INTERLEAD FLASH. INTERLEAD FLASH SHALL NOT EXCEED 0.254mm (0.010") PER SIDE

628 SSOP 1098

NW Package
28-Lead PDIP (Wide 0.600)
 (LTC DWG # 05-08-1520)

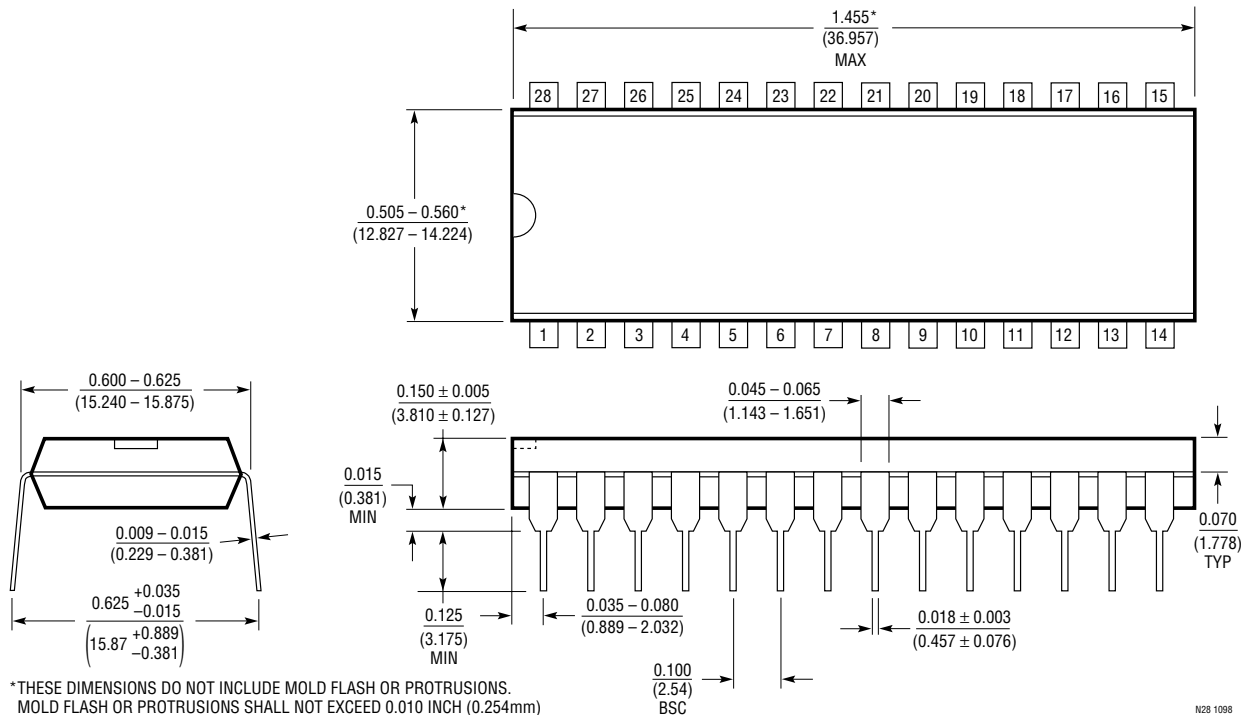

*THESE DIMENSIONS DO NOT INCLUDE MOLD FLASH OR PROTRUSIONS. MOLD FLASH OR PROTRUSIONS SHALL NOT EXCEED 0.010 INCH (0.254mm)

N28 1098

PACKAGE DESCRIPTION Dimensions in inches (millimeters) unless otherwise noted.

SW Package
28-Lead Plastic Small Outline (Wide 0.300)
 (LTC DWG # 05-08-1690)

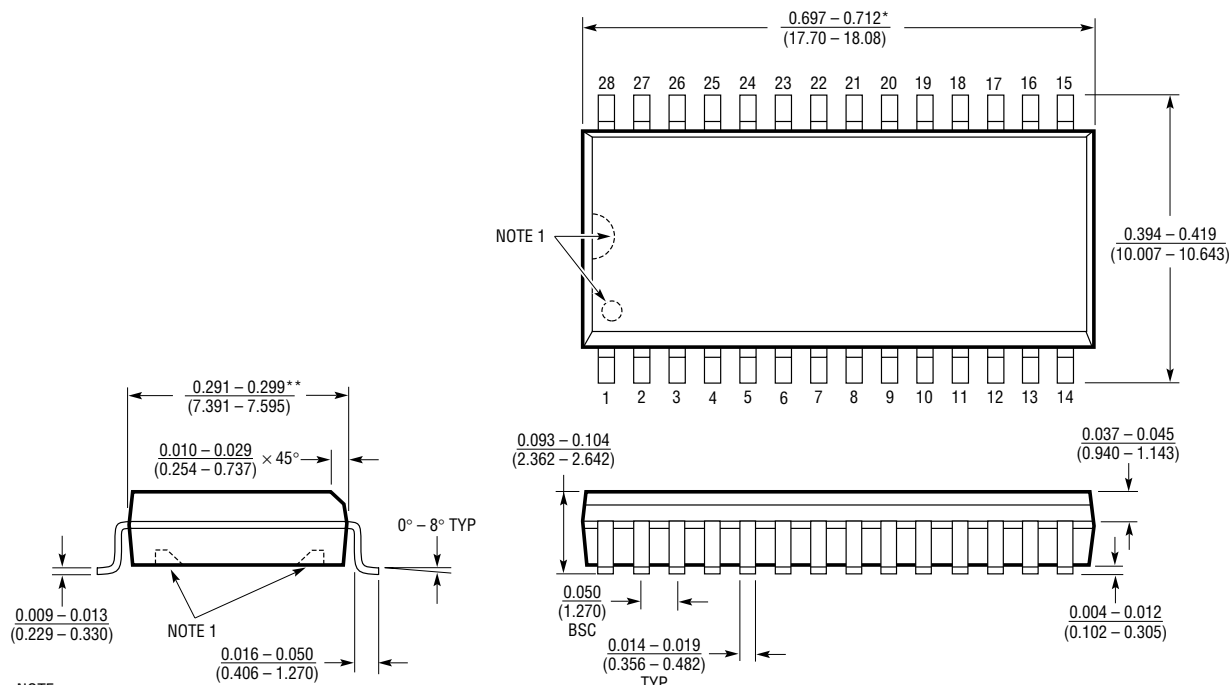

NOTE:
 1. PIN 1 IDENT, NOTCH ON TOP AND CAVITIES ON THE BOTTOM OF PACKAGES ARE THE MANUFACTURING OPTIONS. THE PART MAY BE SUPPLIED WITH OR WITHOUT ANY OF THE OPTIONS
 *DIMENSION DOES NOT INCLUDE MOLD FLASH. MOLD FLASH SHALL NOT EXCEED 0.006" (0.152mm) PER SIDE
 **DIMENSION DOES NOT INCLUDE INTERLEAD FLASH. INTERLEAD FLASH SHALL NOT EXCEED 0.010" (0.254mm) PER SIDE

528 (WIDE) 1098

RELATED PARTS

PART NUMBER	DESCRIPTION	COMMENTS
LTC485	Low Power RS485 Interface Transceiver	Single 5V Supply, Wide Common Mode Range
LT [®] 1137A	Low Power RS232 Transceiver	±15kV IEC-1000-4-2 ESD Protection, Three Drivers, Five Receivers
LTC1320	AppleTalk Transceiver	AppleTalk/Local Talk Compliant
LTC1321/LTC1322/LTC1335	RS232/EIA562/RS485 Transceivers	Configurable, 10kV ESD Protection
LTC1323	Single 5V AppleTalk Transceiver	LocalTalk/AppleTalk Compliant 10kV ESD
LTC1347	5V Low Power RS232 Transceiver	Three Drivers/Five Receivers, Five Receivers Alive in Shutdown
LTC1387	Single 5V RS232/RS485 Transceiver	Single Port, Configurable, 10kV ESD

Looking for pricing, stock, or lifecycle information?

Click below to explore more details on WIN SOURCE:

- ⊖ [View LTC1334CSW#TRPBF on WIN SOURCE](#)
- ⊖ [Analog Devices Inc. Information](#)

Optimize Your Supply Chain with WIN SOURCE Solutions

- ✓ Global Sourcing Solution
- ✓ Obsolete Management
- ✓ Cost Control Management
- ✓ Shortage Management
- ✓ Alternative Solution
- ✓ Excess Inventory Management