



**THE DATASHEET OF
LT6375IMS#TRPBF**



±270V Common Mode Voltage Difference Amplifier

FEATURES

- ±270V Common Mode Voltage Range
- 97dB Minimum CMRR (LT6375A)
- 0.0035% (35ppm) Maximum Gain Error (LT6375A)
- 1ppm/°C Maximum Gain Error Drift
- 2ppm Maximum Gain Nonlinearity
- Wide Supply Voltage Range: 3.3V to 50V
- Rail-to-Rail Output
- 350µA Supply Current
- Selectable Internal Resistor Divider Ratio
- 300µV Maximum Offset Voltage (LT6375A)
- 575kHz –3dB Bandwidth (Resistor Divider = 7)
- 375kHz –3dB Bandwidth (Resistor Divider = 20)
- –40°C to 125°C Specified Temperature Range
- Low Power Shutdown: 20µA (DFN Package Only)
- Space-Saving MSOP and DFN Packages

APPLICATIONS

- High Side or Low Side Current Sensing
- Bidirectional Wide Common Mode Range Current Sensing
- High Voltage to Low Voltage Level Translation
- Precision Difference Amplifier
- Industrial Data-Acquisition Front-Ends
- Replacement for Isolation Circuits

DESCRIPTION

The **LT[®]6375** is a unity-gain difference amplifier which combines excellent DC precision, a very high input common mode range and a wide supply voltage range. It includes a precision op amp and a highly-matched thin film resistor network. It features excellent CMRR, extremely low gain error and extremely low gain drift.

Comparing the LT6375 to existing difference amplifiers with high common mode voltage range, the selectable resistor divider ratios of the LT6375 offer superior system performance by allowing the user to achieve maximum SNR, precision and speed for a specific input common mode voltage range.

The op amp at the core of the LT6375 has Over-The-Top[®] protected inputs which allow for robust operation in environments with unpredictable voltage conditions. See the Applications Information section for more details.

The LT6375 is specified over the –40°C to 125°C temperature range and is available in space-saving MSOP16 and DFN14 packages.

LT, LT, LTC, LTM, Linear Technology, Over-The-Top and the Linear logo are registered trademarks of Linear Technology Corporation. All other trademarks are the property of their respective owners.

TYPICAL APPLICATION

Precision Wide Voltage Range, Bidirectional Current Monitor

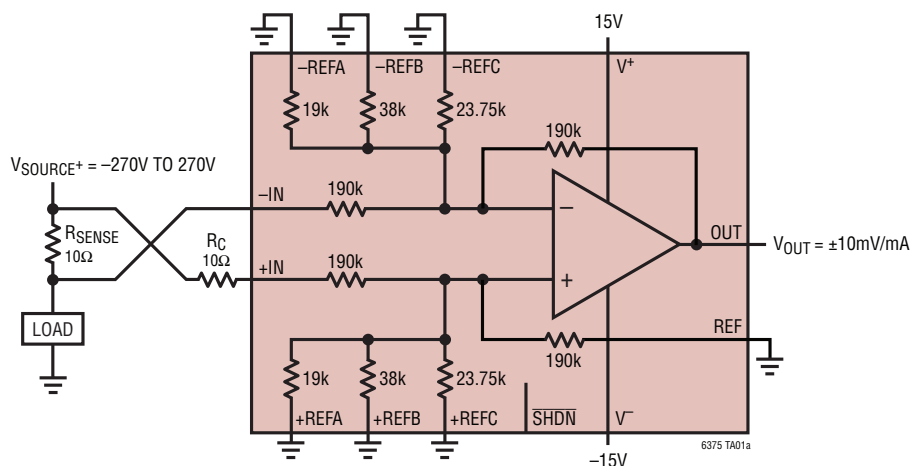

Typical Distribution of CMRR

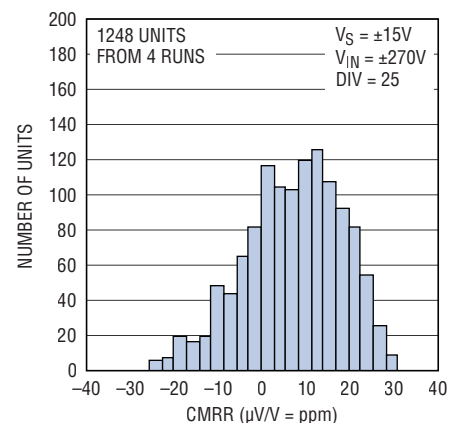

6375fa

LT6375

ABSOLUTE MAXIMUM RATINGS

(Note 1)

Supply Voltages

(V^+ to V^-)60V

+IN, -IN, (Note 2)

Each Input..... $\pm 270V$

Differential $\pm 540V$

+REFA, -REFA, +REFB, -REFB, +REFC, -REFC,
REF, \overline{SHDN} (Note 2) ($V^+ + 0.3V$) to ($V^- - 0.3V$)

Output Current (Continuous) (Note 6)50mA

Output Short-Circuit Duration (Note 3) Thermally Limited
Temperature Range (Notes 4, 5)

LT6375I..... $-40^\circ C$ to $85^\circ C$

LT6375H $-40^\circ C$ to $125^\circ C$

Storage Temperature Range $-65^\circ C$ to $150^\circ C$

MSOP Lead Temperature (Soldering, 10 sec)..... $300^\circ C$

PIN CONFIGURATION

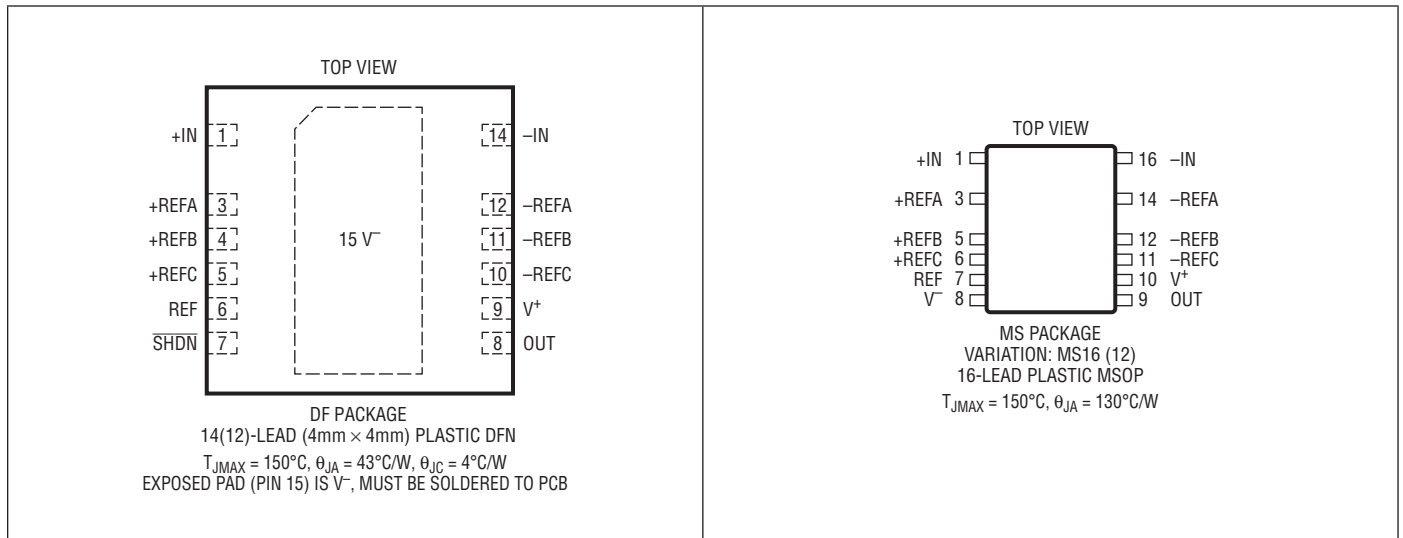

ORDER INFORMATION

LEAD FREE FINISH	TAPE AND REEL	PART MARKING*	PACKAGE DESCRIPTION	TEMPERATURE RANGE
LT6375IDF#PBF	LT6375IDF#TRPBF	6375	14-Lead (4mm x 4mm) Plastic DFN	$-40^\circ C$ to $85^\circ C$
LT6375HDF#PBF	LT6375HDF#TRPBF	6375	14-Lead (4mm x 4mm) Plastic DFN	$-40^\circ C$ to $125^\circ C$
LT6375AHDF#PBF	LT6375AHDF#TRPBF	6375	14-Lead (4mm x 4mm) Plastic DFN	$-40^\circ C$ to $125^\circ C$
LT6375IMS#PBF	LT6375IMS#TRPBF	6375	16-Lead Plastic MSOP	$-40^\circ C$ to $85^\circ C$
LT6375HMS#PBF	LT6375HMS#TRPBF	6375	16-Lead Plastic MSOP	$-40^\circ C$ to $125^\circ C$
LT6375AHMS#PBF	LT6375AHMS#TRPBF	6375	16-Lead Plastic MSOP	$-40^\circ C$ to $125^\circ C$

Consult LTC Marketing for parts specified with wider operating temperature ranges. *The temperature grade is identified by a label on the shipping container.

For more information on lead free part marking, go to: <http://www.linear.com/leadfree/>

For more information on tape and reel specifications, go to: <http://www.linear.com/tapeandree/>. Some packages are available in 500 unit reels through designated sales channels with #TRMPBF suffix.

ELECTRICAL CHARACTERISTICS The ● denotes the specifications which apply over the full operating temperature range, $-40^{\circ}\text{C} < T_A < 85^{\circ}\text{C}$ for I-grade parts, $-40^{\circ}\text{C} < T_A < 125^{\circ}\text{C}$ for H-grade parts, otherwise specifications are at $T_A = 25^{\circ}\text{C}$, $V^+ = 15\text{V}$, $V^- = -15\text{V}$, $V_{\text{CM}} = V_{\text{OUT}} = V_{\text{REF}} = 0\text{V}$. V_{CMOP} is the common mode voltage of the internal op amp. For Resistor Divider Ratio = 7, $\pm\text{REFA} = \pm\text{REFC} = \text{OPEN}$, $\pm\text{REFB} = 0\text{V}$. For Resistor Divider Ratio = 20, $\pm\text{REFA} = \pm\text{REFC} = 0\text{V}$, $\pm\text{REFB} = \text{OPEN}$. For Resistor Divider Ratio = 25, $\pm\text{REFA} = \pm\text{REFB} = \pm\text{REFC} = 0\text{V}$.

SYMBOL	PARAMETER	CONDITIONS	LT6375A			LT6375			UNITS	
			MIN	TYP	MAX	MIN	TYP	MAX		
G	Gain	$V_{\text{OUT}} = \pm 10\text{V}$		1			1		V/V	
ΔG	Gain Error	$V_{\text{OUT}} = \pm 10\text{V}$	●	± 0.0007	± 0.0035 ± 0.005		± 0.001	± 0.006 ± 0.0075	% %	
$\Delta\text{G}/\Delta\text{T}$	Gain Drift vs Temperature (Note 6)	$V_{\text{OUT}} = \pm 10\text{V}$	●	± 0.2	± 1		± 0.2	± 1	ppm/ $^{\circ}\text{C}$	
GNL	Gain Nonlinearity	$V_{\text{OUT}} = \pm 10\text{V}$	●	± 1	± 2 ± 3		± 1	± 2 ± 3	ppm ppm	
V_{OS}	Output Offset Voltage	$V^- < V_{\text{CMOP}} < V^+ - 1.75\text{V}$ Resistor Divider Ratio = 7 Resistor Divider Ratio = 7 Resistor Divider Ratio = 20 Resistor Divider Ratio = 20 Resistor Divider Ratio = 25 Resistor Divider Ratio = 25	●	100	300		120	450	μV μV μV μV μV μV	
$\Delta V_{\text{OS}}/\Delta\text{T}$	Output Offset Voltage Drift (Note 6)	$V^- < V_{\text{CMOP}} < V^+ - 1.75\text{V}$ Resistor Divider Ratio = 7 Resistor Divider Ratio = 20	●	3	9		4	12	$\mu\text{V}/^{\circ}\text{C}$ $\mu\text{V}/^{\circ}\text{C}$	
R_{IN}	Input Impedance (Note 8)	Common Mode Resistor Divider Ratio = 7 Resistor Divider Ratio = 20 Resistor Divider Ratio = 25 Differential	●	93	111	129	93	111	129	k Ω k Ω k Ω k Ω
CMRR	Common Mode Rejection Ratio	MS16 Package Resistor Divider Ratio = 7, $V_{\text{CM}} = \pm 28\text{V}$ Resistor Divider Ratio = 7, $V_{\text{CM}} = \pm 28\text{V}$ Resistor Divider Ratio = 20, $V_{\text{CM}} = \pm 28\text{V}$ Resistor Divider Ratio = 20, $V_{\text{CM}} = \pm 28\text{V}$ Resistor Divider Ratio = 25, $V_{\text{CM}} = \pm 28\text{V}$ Resistor Divider Ratio = 25, $V_{\text{CM}} = \pm 28\text{V}$ Resistor Divider Ratio = 25, $V_{\text{CM}} = \pm 270\text{V}$ Resistor Divider Ratio = 25, $V_{\text{CM}} = \pm 270\text{V}$ DF14 Package Resistor Divider Ratio = 7, $V_{\text{CM}} = \pm 28\text{V}$ Resistor Divider Ratio = 7, $V_{\text{CM}} = \pm 28\text{V}$ Resistor Divider Ratio = 20, $V_{\text{CM}} = \pm 28\text{V}$ Resistor Divider Ratio = 20, $V_{\text{CM}} = \pm 28\text{V}$ Resistor Divider Ratio = 25, $V_{\text{CM}} = \pm 28\text{V}$ Resistor Divider Ratio = 25, $V_{\text{CM}} = \pm 28\text{V}$ Resistor Divider Ratio = 25, $V_{\text{CM}} = \pm 270\text{V}$ Resistor Divider Ratio = 25, $V_{\text{CM}} = \pm 270\text{V}$	●	96	106		89	100		dB dB dB dB dB dB dB dB dB dB dB dB
V_{CM}	Input Voltage Range (Note 7)		●	-270		270	-270		270	V
PSRR	Power Supply Rejection Ratio	$V_S = \pm 1.65\text{V}$ to $\pm 25\text{V}$, $V_{\text{CM}} = V_{\text{OUT}} = \text{Mid-Supply}$ Resistor Divider Ratio = 7 Resistor Divider Ratio = 20 Resistor Divider Ratio = 25	●	101	115		98	110		dB dB dB

ELECTRICAL CHARACTERISTICS The ● denotes the specifications which apply over the full operating temperature range, $-40^{\circ}\text{C} < T_A < 85^{\circ}\text{C}$ for I-grade parts, $-40^{\circ}\text{C} < T_A < 125^{\circ}\text{C}$ for H-grade parts, otherwise specifications are at $T_A = 25^{\circ}\text{C}$, $V^+ = 15\text{V}$, $V^- = -15\text{V}$, $V_{\text{CM}} = V_{\text{OUT}} = V_{\text{REF}} = 0\text{V}$. V_{CMOP} is the common mode voltage of the internal op amp. For Resistor Divider Ratio = 7, $\pm\text{REFA} = \pm\text{REFC} = \text{OPEN}$, $\pm\text{REFB} = 0\text{V}$. For Resistor Divider Ratio = 20, $\pm\text{REFA} = \pm\text{REFC} = 0\text{V}$, $\pm\text{REFB} = \text{OPEN}$. For Resistor Divider Ratio = 25, $\pm\text{REFA} = \pm\text{REFB} = \pm\text{REFC} = 0\text{V}$.

SYMBOL	PARAMETER	CONDITIONS	LT6375A			LT6375			UNITS
			MIN	TYP	MAX	MIN	TYP	MAX	
e_{no}	Output Referred Noise Voltage Density	$f = 1\text{kHz}$		250		250		$\text{nV}/\sqrt{\text{Hz}}$	
		Resistor Divider Ratio = 7		508		508		$\text{nV}/\sqrt{\text{Hz}}$	
		Resistor Divider Ratio = 25		599		599		$\text{nV}/\sqrt{\text{Hz}}$	
	Output Referred Noise Voltage	$f = 0.1\text{Hz to } 10\text{Hz}$		10		10		$\mu\text{V}_{\text{P-P}}$	
		Resistor Divider Ratio = 7		20		20		$\mu\text{V}_{\text{P-P}}$	
		Resistor Divider Ratio = 25		25		25		$\mu\text{V}_{\text{P-P}}$	
V_{OL}	Output Voltage Swing Low (Referred to V^-)	No Load	●	5	50	5	50	mV	
		$I_{\text{SINK}} = 5\text{mA}$	●	280	500	280	500	mV	
V_{OH}	Output Voltage Swing High (Referred to V^+)	No Load	●	5	20	5	20	mV	
		$I_{\text{SOURCE}} = 5\text{mA}$	●	400	750	400	750	mV	
I_{SC}	Short-Circuit Output Current	50Ω to V^+	●	10	28	10	28	mA	
		50Ω to V^-	●	10	30	10	30	mA	
SR	Slew Rate	$\Delta V_{\text{OUT}} = \pm 5\text{V}$	●	1.6	2.4	1.6	2.4	$\text{V}/\mu\text{s}$	
BW	Small Signal -3dB Bandwidth	Resistor Divider Ratio = 7		575		575		kHz	
		Resistor Divider Ratio = 20		375		375		kHz	
		Resistor Divider Ratio = 25		310		310		kHz	
t_{s}	Settling Time	Resistor Divider Ratio = 7							
		0.01%, $\Delta V_{\text{OUT}} = 10\text{V}$		41		41		μs	
		0.1%, $\Delta V_{\text{OUT}} = 10\text{V}$		14		14		μs	
		0.01%, $\Delta V_{\text{CM}} = 10\text{V}$, $\Delta V_{\text{DIFF}} = 0\text{V}$		100		100		μs	
		Resistor Divider Ratio = 20							
		0.01%, $\Delta V_{\text{OUT}} = 10\text{V}$		31		31		μs	
		0.1%, $\Delta V_{\text{OUT}} = 10\text{V}$		11		11		μs	
		0.01%, $\Delta V_{\text{CM}} = 10\text{V}$, $\Delta V_{\text{DIFF}} = 0\text{V}$		100		100		μs	
		Resistor Divider Ratio = 25							
0.01%, $\Delta V_{\text{OUT}} = 10\text{V}$		26		26		μs			
0.1%, $\Delta V_{\text{OUT}} = 10\text{V}$		8		8		μs			
0.01%, $\Delta V_{\text{CM}} = 10\text{V}$, $\Delta V_{\text{DIFF}} = 0\text{V}$		20		20		μs			
V_{S}	Supply Voltage		●	3	50	3	50	V	
				3.3	50	3.3	50	V	
t_{ON}	Turn-On Time			16		16		μs	
V_{IL}	$\overline{\text{SHDN}}$ Input Logic Low (Referred to V^+)		●		-2.5		-2.5	V	
V_{IH}	$\overline{\text{SHDN}}$ Input Logic High (Referred to V^+)		●	-1.2		-1.2		V	
I_{SHDN}	$\overline{\text{SHDN}}$ Pin Current		●	-10	-15	-10	-15	μA	
I_{S}	Supply Current	Active, $V_{\text{SHDN}} \geq V^+ - 1.2\text{V}$	●	350	400	350	400	μA	
		Active, $V_{\text{SHDN}} \geq V^+ - 1.2\text{V}$	●		600		600	μA	
		Shutdown, $V_{\text{SHDN}} \leq V^+ - 2.5\text{V}$	●	20	25	20	25	μA	
		Shutdown, $V_{\text{SHDN}} \leq V^+ - 2.5\text{V}$	●		70		70	μA	

ELECTRICAL CHARACTERISTICS The ● denotes the specifications which apply over the full operating temperature range, $-40^{\circ}\text{C} < T_A < 85^{\circ}\text{C}$ for I-grade parts, $-40^{\circ}\text{C} < T_A < 125^{\circ}\text{C}$ for H-grade parts, otherwise specifications are at $T_A = 25^{\circ}\text{C}$, $V^+ = 5\text{V}$, $V^- = 0\text{V}$, $V_{\text{CM}} = V_{\text{OUT}} = V_{\text{REF}} = \text{Mid-Supply}$. V_{CMOP} is the common mode voltage of the internal op amp. For Resistor Divider Ratio = 7, $\pm\text{REFA} = \pm\text{REFC} = \text{OPEN}$, $\pm\text{REFB} = \text{Mid-Supply}$. For Resistor Divider Ratio = 20, $\pm\text{REFA} = \pm\text{REFC} = \text{Mid-Supply}$, $\pm\text{REFB} = \text{OPEN}$. For Resistor Divider Ratio = 25, $\pm\text{REFA} = \pm\text{REFB} = \pm\text{REFC} = \text{Mid-Supply}$.

SYMBOL	PARAMETER	CONDITIONS	LT6375A			LT6375			UNITS
			MIN	TYP	MAX	MIN	TYP	MAX	
	Output Referred Noise Voltage	$f = 0.1\text{Hz to } 10\text{Hz}$ Resistor Divider Ratio = 7 Resistor Divider Ratio = 20 Resistor Divider Ratio = 25		10 20 25		10 20 25		$\mu\text{V}_{\text{P-P}}$ $\mu\text{V}_{\text{P-P}}$ $\mu\text{V}_{\text{P-P}}$	
V_{OL}	Output Voltage Swing Low (Referred to V^-)	No Load $I_{\text{SINK}} = 5\text{mA}$	● ●	5 280	50 500	5 280	50 500	mV mV	
V_{OH}	Output Voltage Swing High (Referred to V^+)	No Load $I_{\text{SOURCE}} = 5\text{mA}$	● ●	5 400	20 750	5 400	20 750	mV mV	
I_{SC}	Short-Circuit Output Current	50Ω to V^+ 50Ω to V^-	● ●	10 10	27 25	10 10	27 25	mA mA	
SR	Slew Rate	$\Delta V_{\text{OUT}} = 3\text{V}$	●	1.3	2	1.3	2	V/ μs	
BW	Small Signal -3dB Bandwidth	Resistor Divider Ratio = 7 Resistor Divider Ratio = 20 Resistor Divider Ratio = 25		565 380 325		565 380 325		kHz kHz kHz	
t_{S}	Settling Time	Resistor Divider Ratio = 7 0.01%, $\Delta V_{\text{OUT}} = 2\text{V}$ 0.1%, $\Delta V_{\text{OUT}} = 2\text{V}$ 0.01%, $\Delta V_{\text{CM}} = 2\text{V}$, $\Delta V_{\text{DIFF}} = 0\text{V}$		18 10 64		18 10 64		μs μs μs	
		Resistor Divider Ratio = 20 0.01%, $\Delta V_{\text{OUT}} = 2\text{V}$ 0.1%, $\Delta V_{\text{OUT}} = 2\text{V}$ 0.01%, $\Delta V_{\text{CM}} = 2\text{V}$, $\Delta V_{\text{DIFF}} = 0\text{V}$		24 7 48		24 7 48		μs μs μs	
		Resistor Divider Ratio = 25 0.01%, $\Delta V_{\text{OUT}} = 2\text{V}$ 0.1%, $\Delta V_{\text{OUT}} = 2\text{V}$ 0.01%, $\Delta V_{\text{CM}} = 2\text{V}$, $\Delta V_{\text{DIFF}} = 0\text{V}$		27 9 20		27 9 20		μs μs μs	
V_{S}	Supply Voltage		●	3 3.3	50 50	3 3.3	50 50	V V	
t_{ON}	Turn-On Time			22		22		μs	
V_{IL}	$\overline{\text{SHDN}}$ Input Logic Low (Referred to V^+)		●		-2.5		-2.5	V	
V_{IH}	$\overline{\text{SHDN}}$ Input Logic High (Referred to V^+)		●	-1.2		-1.2		V	
$I_{\overline{\text{SHDN}}}$	$\overline{\text{SHDN}}$ Pin Current		●	-10	-15	-10	-15	μA	
I_{S}	Supply Current	Active, $V_{\overline{\text{SHDN}}} \geq V^+ - 1.2\text{V}$ Active, $V_{\overline{\text{SHDN}}} \geq V^+ - 1.2\text{V}$ Shutdown, $V_{\overline{\text{SHDN}}} \leq V^+ - 2.5\text{V}$ Shutdown, $V_{\overline{\text{SHDN}}} \leq V^+ - 2.5\text{V}$	● ● ●	330 15	370 20 40	330 15	370 20 40	μA μA μA μA	

ELECTRICAL CHARACTERISTICS

Note 1: Stresses beyond those listed under Absolute Maximum Ratings may cause permanent damage to the device. Exposure to any Absolute Maximum Rating condition for extended periods may affect device reliability and lifetime.

Note 2: See Common Mode Voltage Range in the Applications Information section of this data sheet for other considerations when taking +IN/-IN pins to $\pm 270V$. All other pins should not be taken more than 0.3V beyond the supply rails.

Note 3: A heat sink may be required to keep the junction temperature below absolute maximum. This depends on the power supply, input voltages and the output current.

Note 4: The LT6375I is guaranteed functional over the operating temperature range of $-40^{\circ}C$ to $85^{\circ}C$. The LT6375H is guaranteed functional over the operating temperature range of $-40^{\circ}C$ to $125^{\circ}C$.

Note 5: The LT6375I is guaranteed to meet specified performance from $-40^{\circ}C$ to $85^{\circ}C$. The LT6375H is guaranteed to meet specified performance from $-40^{\circ}C$ to $125^{\circ}C$.

Note 6: This parameter is not 100% tested.

Note 7: Input voltage range is guaranteed by the CMRR test at $V_S = \pm 15V$ and all REF pins at ground (Resistor Divider Ratio = 25). For the other voltages, this parameter is guaranteed by design and through correlation with the $\pm 15V$ test. See Common Mode Voltage Range in the Applications Information section to determine the valid input voltage range under various operating conditions.

Note 8: Input impedance is tested by a combination of direct measurement and correlation to the CMRR and gain error tests.

TYPICAL PERFORMANCE CHARACTERISTICS $T_A = 25^{\circ}C, V_S = \pm 15V$, unless otherwise noted.

Typical Distribution of CMRR

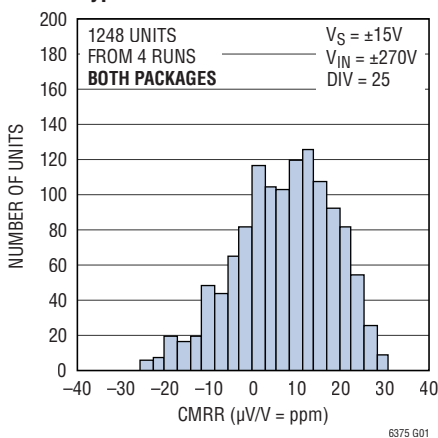

Typical Distribution of CMRR

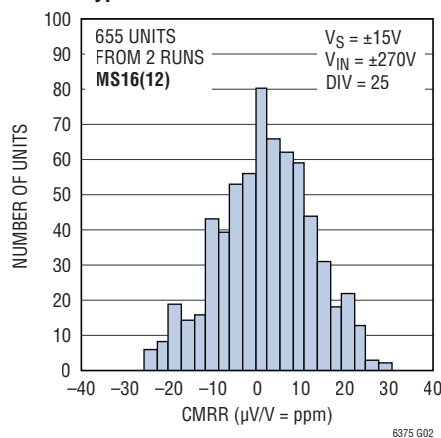

Typical Distribution of CMRR

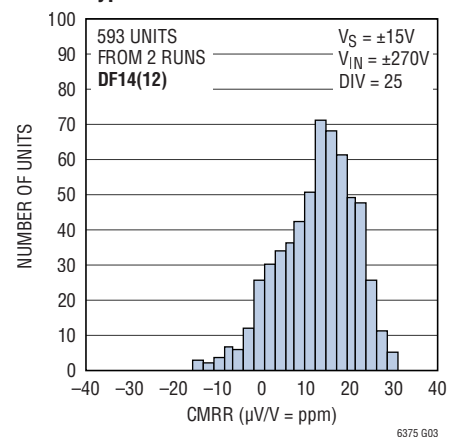

Typical Distribution of Gain Error

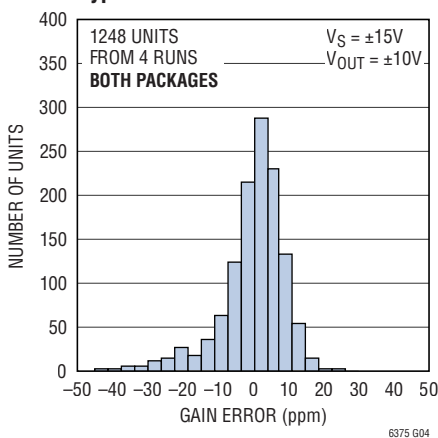

Typical Distribution of Gain Error

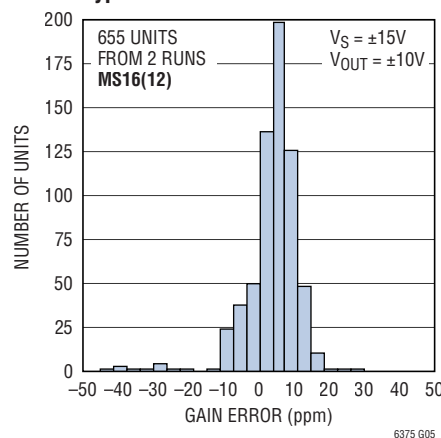

Typical Distribution of Gain Error

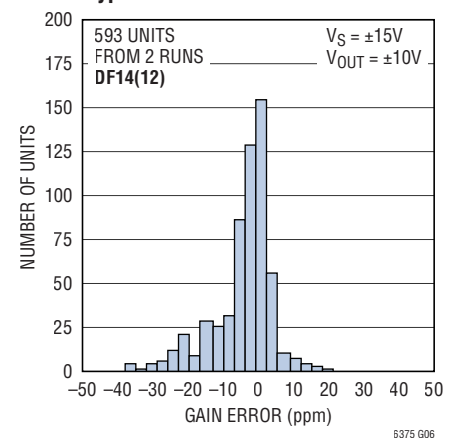

TYPICAL PERFORMANCE CHARACTERISTICS $T_A = 25^\circ\text{C}$, $V_S = \pm 15\text{V}$, unless otherwise noted.

Typical Distribution of Gain Nonlinearity

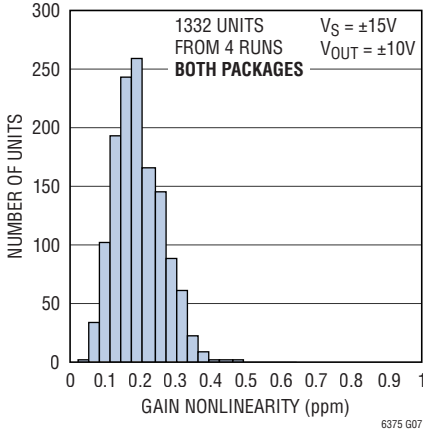

CMRR vs Frequency

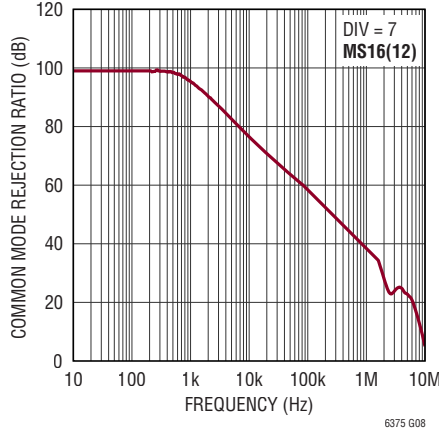

Common Mode Voltage Range vs Power Supply Voltage

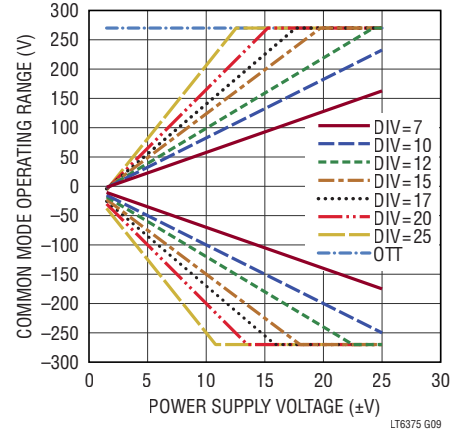

Typical Gain Error for $R_L = 10\text{k}\Omega$ (Curves Offset for Clarity)

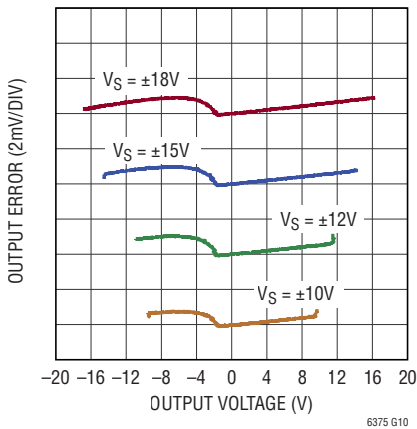

Typical Gain Error for $R_L = 5\text{k}\Omega$ (Curves Offset for Clarity)

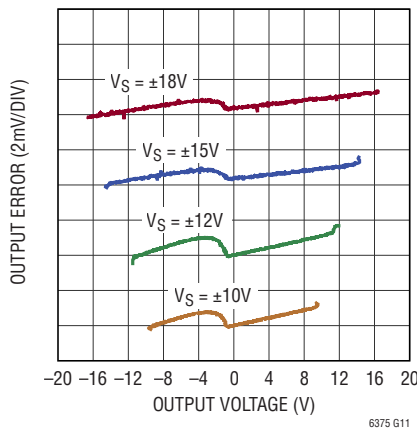

Typical Gain Error for $R_L = 2\text{k}\Omega$ (Curves Offset for Clarity)

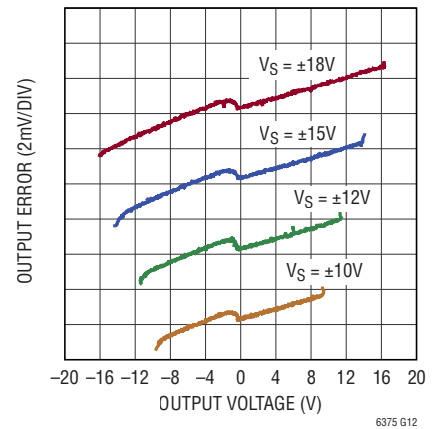

Typical Gain Error for Low Supply Voltages (Curves Offset for Clarity)

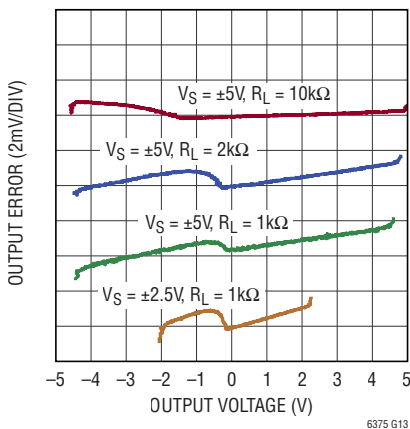

Gain Nonlinearity

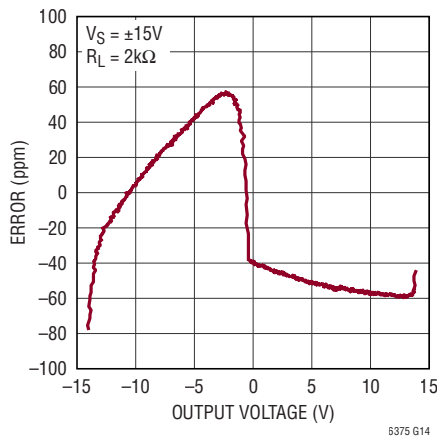

Gain Nonlinearity

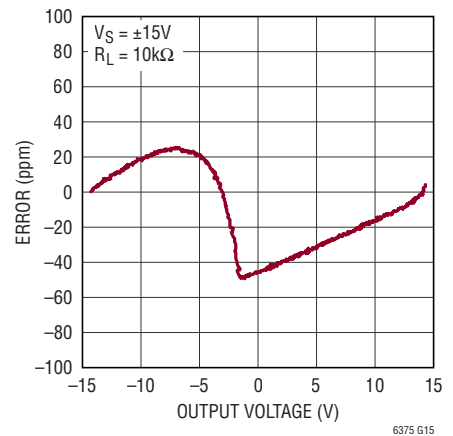

TYPICAL PERFORMANCE CHARACTERISTICS $T_A = 25^\circ\text{C}$, $V_S = \pm 15\text{V}$, unless otherwise noted.

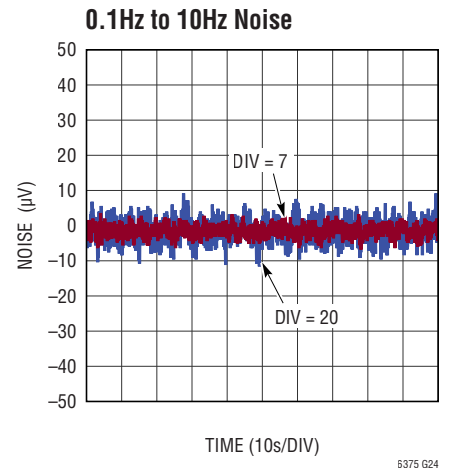
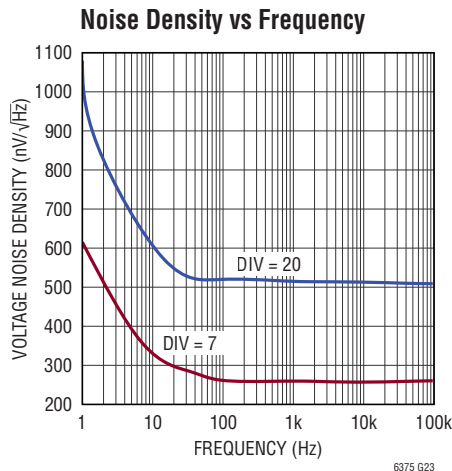
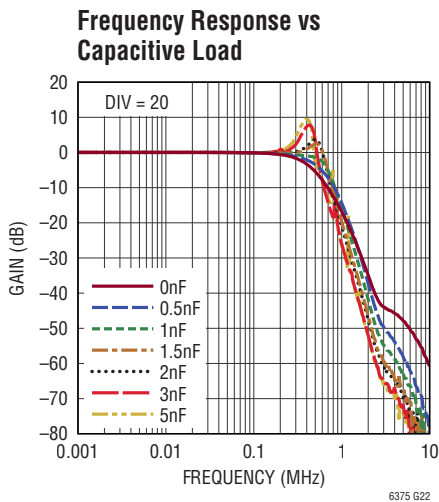
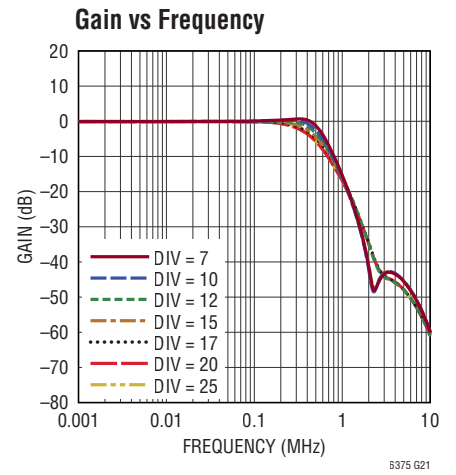
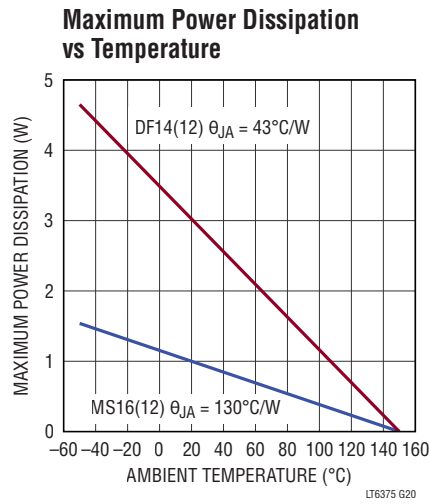
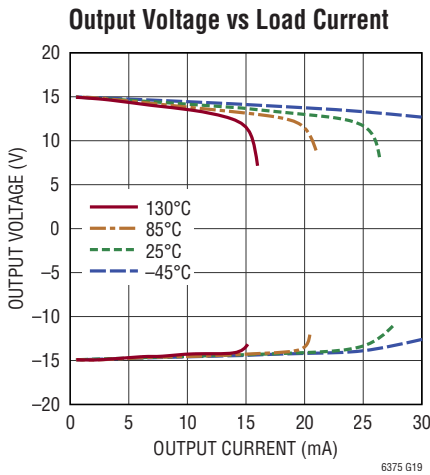
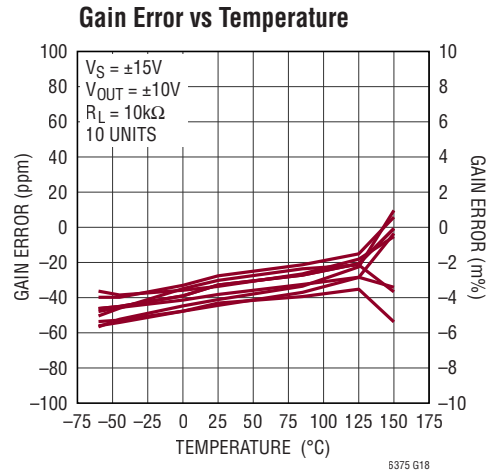
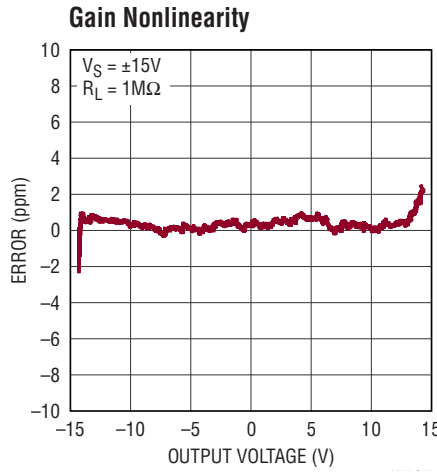
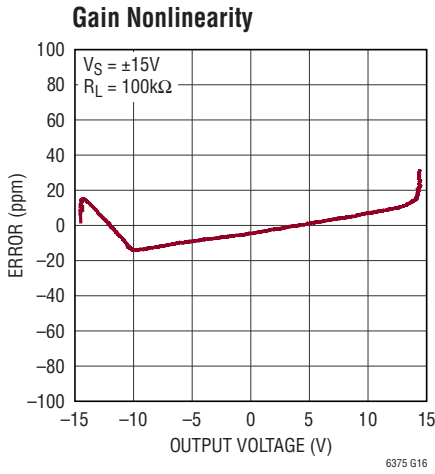

TYPICAL PERFORMANCE CHARACTERISTICS $T_A = 25^\circ\text{C}$, $V_S = \pm 15\text{V}$, unless otherwise noted.

Positive PSRR vs Frequency

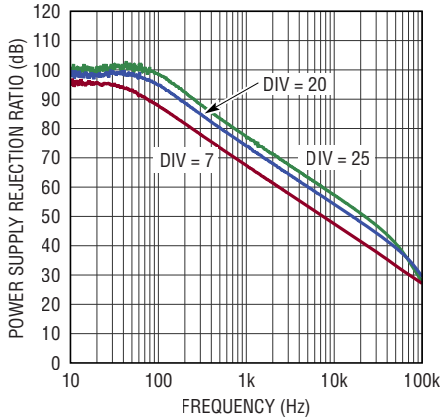

Negative PSRR vs Frequency

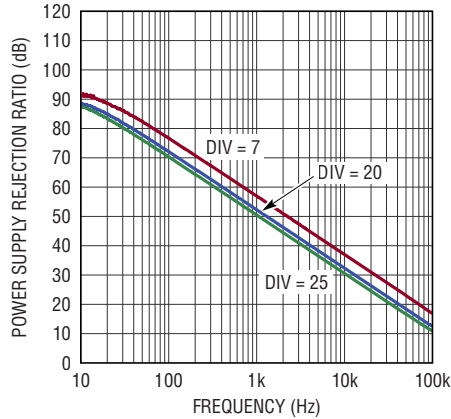

Slew Rate vs Temperature

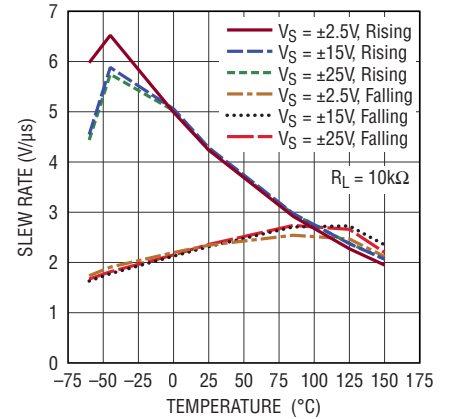

Large-Signal Step Response

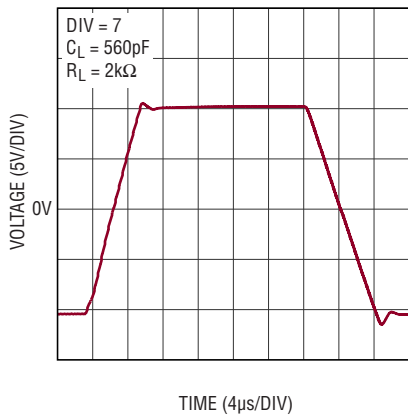

Small-Signal Step Response

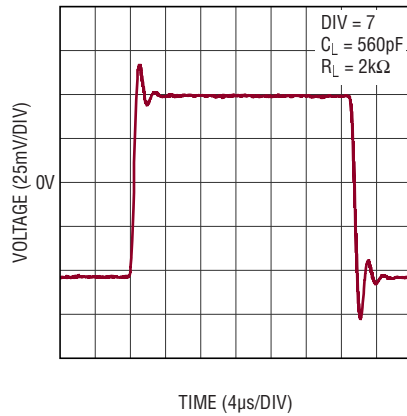

Small-Signal Step Response vs Capacitive Load

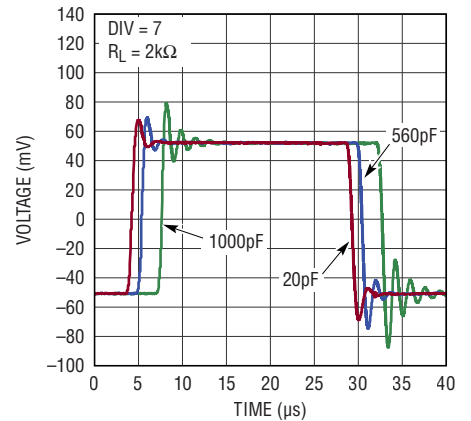

Large-Signal Step Response

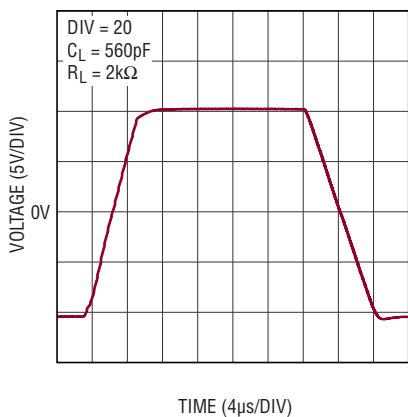

Small-Signal Step Response

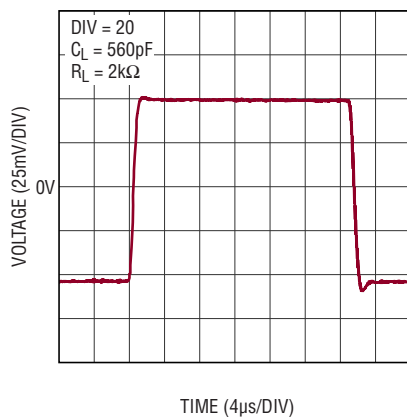

Small-Signal Step Response vs Capacitive Load

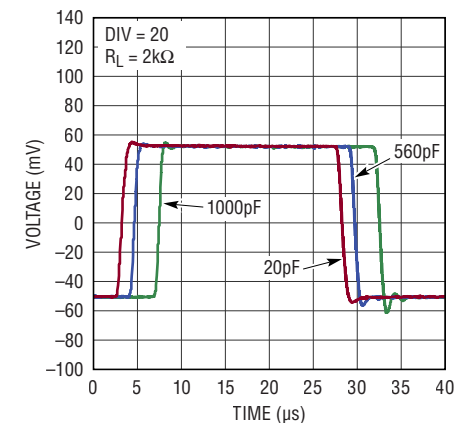

TYPICAL PERFORMANCE CHARACTERISTICS $T_A = 25^\circ\text{C}$, $V_S = \pm 15\text{V}$, unless otherwise noted.

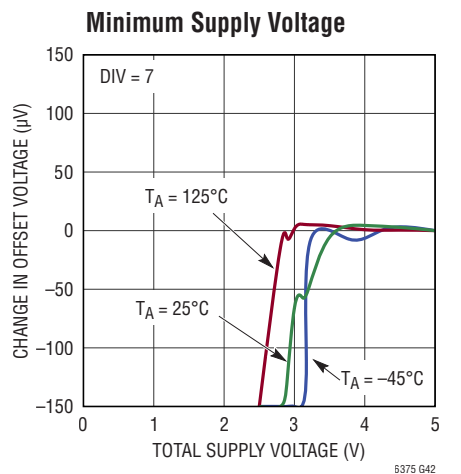
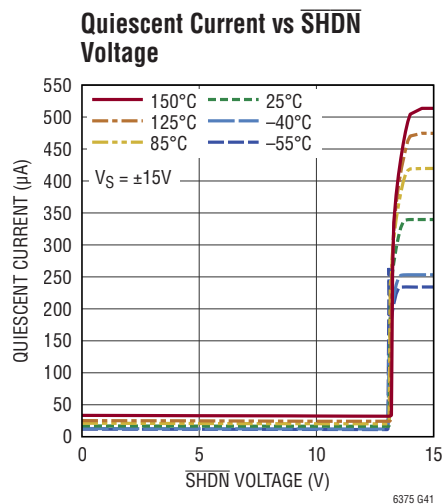
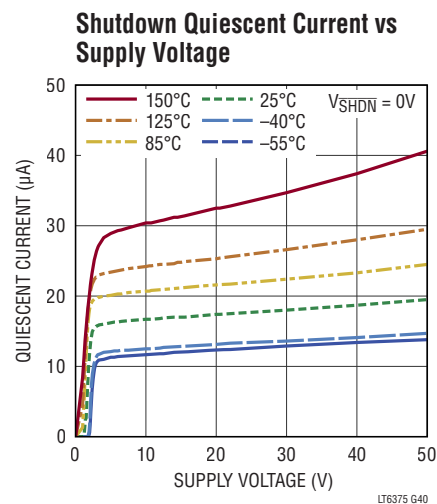
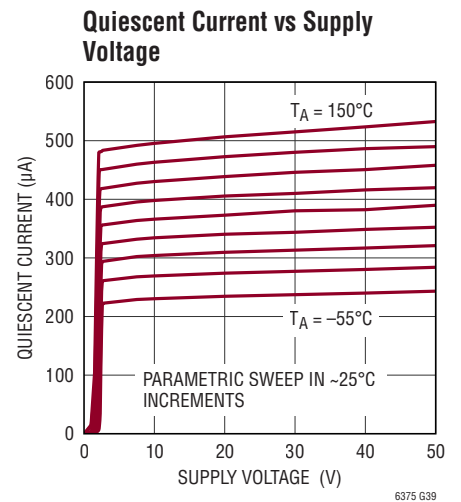
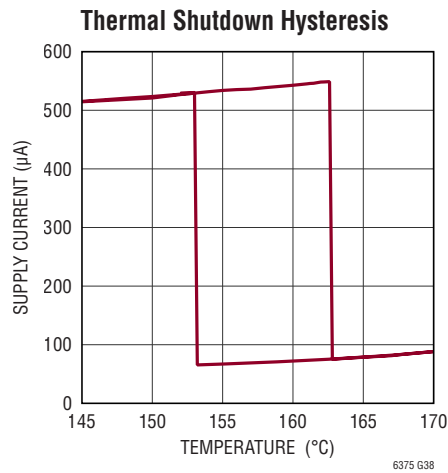
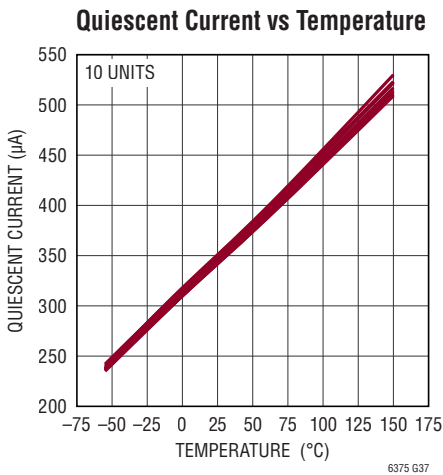
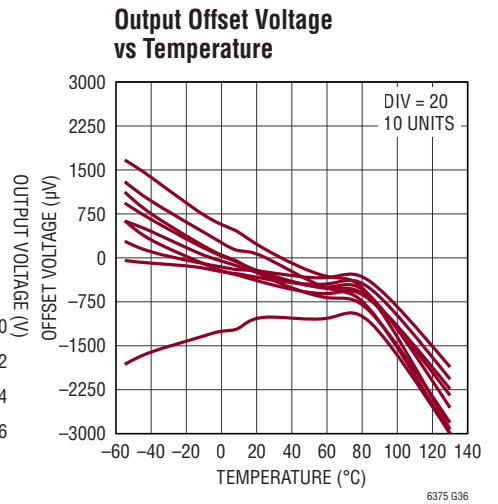
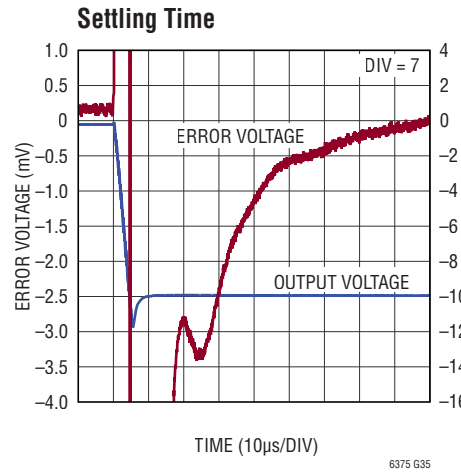
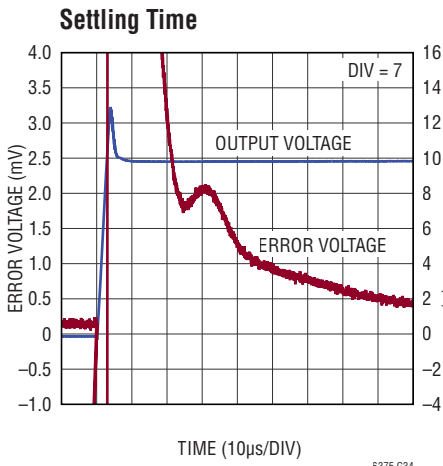

TYPICAL PERFORMANCE CHARACTERISTICS $T_A = 25^\circ\text{C}$, $V_S = \pm 15\text{V}$, unless otherwise noted.

Typical Distribution of Output Offset Voltage

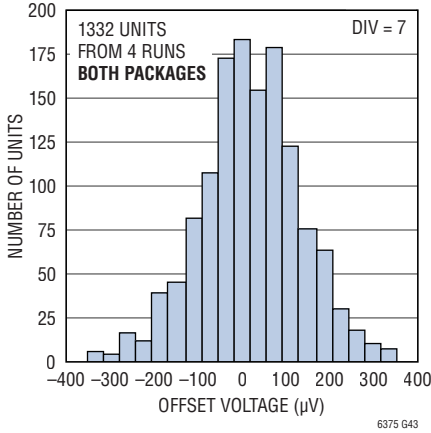

Typical Distribution of Output Offset Voltage

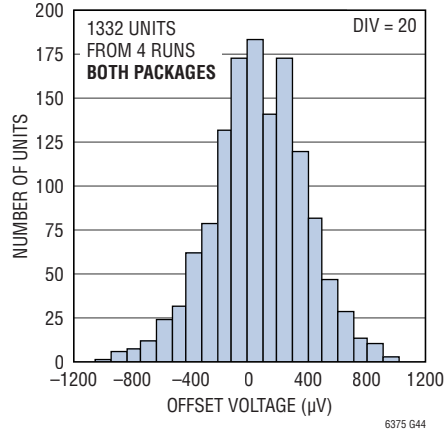

Typical Distribution of Output Offset Voltage

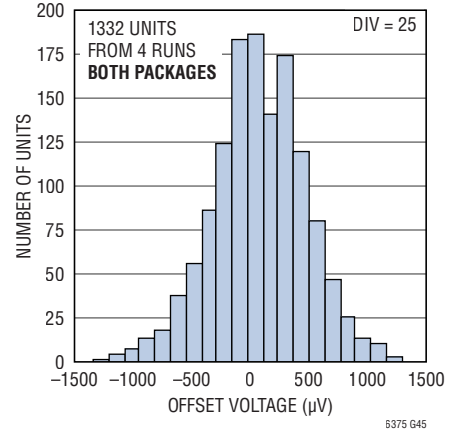

Typical Distribution of PSRR

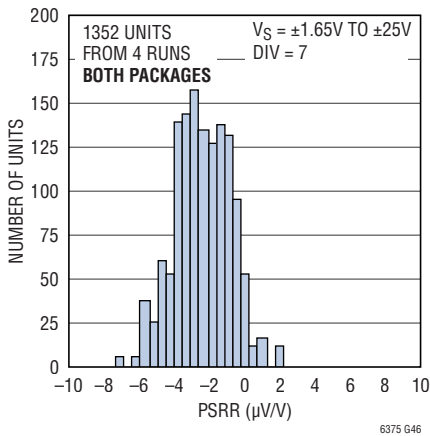

Typical Distribution of PSRR

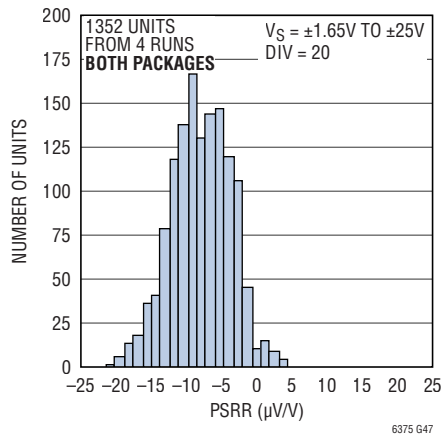

Typical Distribution of PSRR

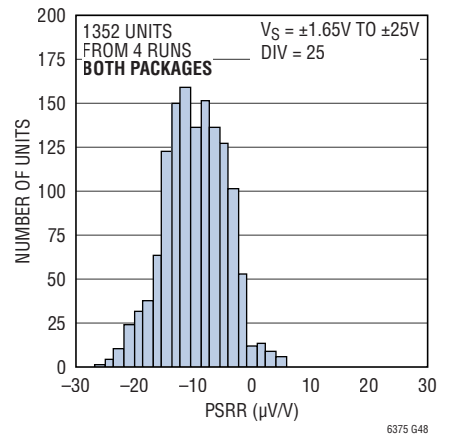

PIN FUNCTIONS (DFN/MSOP)

V⁺ (Pin 9/Pin 10): Positive Supply Pin.

V⁻ (Exposed Pad Pin 15/Pin 8): Negative Supply Pin.

OUT (Pin 8/Pin 9): Output Pin.

+IN (Pin 1/Pin 1): Noninverting Input Pin. Accepts input voltages from 270V to -270V.

+REFA (Pin 3/Pin 3): Reference Pin A. Sets the input common mode range and the output noise and offset.

+REFB (Pin 4/Pin 5): Reference Pin B. Sets the input common mode range and the output noise and offset.

+REFC (Pin 5/Pin 6): Reference Pin C. Sets the input common mode range and the output noise and offset.

-IN (Pin 14/Pin 16): Inverting Input Pin. Accepts input voltages from 270V to -270V.

-REFA (Pin 12/Pin 14): Reference Pin A. Sets the input common mode range and the output noise and offset.

-REFB (Pin 11/Pin 12): Reference Pin B. Sets the input common mode range and the output noise and offset.

-REFC (Pin 10/Pin 11): Reference Pin C. Sets the input common mode range and the output noise and offset.

REF (Pin 6/Pin 7): Reference Input. Sets the output level when the difference between the inputs is zero.

SHDN (Pin 7) DFN Only: Shutdown Pin. Amplifier is active when this pin is tied to V⁺ or left floating. Pulling the pin >2.5V below V⁺ causes the amplifier to enter a low power state.

BLOCK DIAGRAM

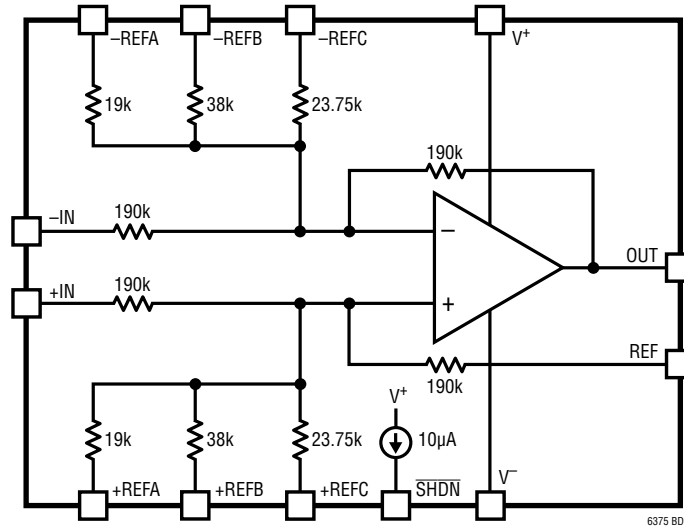

APPLICATIONS INFORMATION

TRANSFER FUNCTION

The LT6375 is a unity-gain difference amplifier with the transfer function:

$$V_{OUT} = (V_{+IN} - V_{-IN}) + V_{REF}$$

The voltage on the REF pin sets the output voltage when the differential input voltage ($V_{DIFF} = V_{+IN} - V_{-IN}$) is zero. This reference is used to shift the output voltage to the desired input level of the next stage of the signal chain.

BENEFITS OF SELECTABLE RESISTOR DIVIDER RATIOS

The LT6375 offers smaller package size, better gain accuracy and better noise performance than existing high common mode voltage range difference amplifiers. Additionally, the LT6375 allows the user to maximize system performance by selecting the resistor divider ratio (DIV) appropriate to their input common mode voltage range. A higher resistor divider ratio (DIV) enables higher common mode voltage range at the input pins, but also increases output noise, output offset/drift and decreases the -3dB bandwidth. Therefore, a trade-off exists between input range and DC, AC, and drift performance of the part. It

is recommended that the user choose the lowest resistor divider ratio that achieves the required input common mode voltage range in their application to maximize the system SNR, precision and speed.

Table 1 shows the noise, offset/drift, and -3dB bandwidth of the LT6375 for all different reference pins configurations.

COMMON MODE VOLTAGE RANGE

The wide common mode voltage range of the LT6375 is enabled by both a resistor divider at the input of the op amp and by an internal op amp that can withstand high input voltages.

The internal resistor network of the LT6375 divides down the input common mode voltage. The resulting voltage at the op amp inputs determines the op amp's operating region. In the configuration shown in Figure 1, a resistor divider is created at both op amp inputs by the 190k input resistor and the resistance from each input to ground, which is $\sim 31.66\text{k}$. The resistance to ground is formed by the 38k (REFB resistors) in parallel with the 190k (feedback/REF resistor). The result is a divide by 7 of the input voltage. As shown in Tables 1 to 5, different connections to reference pins (i.e. pins +REFA, -REFA, +REFB, -REFB,

APPLICATIONS INFORMATION

Table 1. LT6375 Performance at Different Resistor Divider Ratios

RESISTOR DIVIDER OPTIONS				RESISTOR DIVIDER RATIO (DIV)	DIFFERENTIAL GAIN	OUTPUT NOISE AT 1kHz (nV/ $\sqrt{\text{Hz}}$)	MAXIMUM OFFSET (μV)		MAXIMUM OFFSET DRIFT ($\mu\text{V}/^\circ\text{C}$)		-3dB BANDWIDTH (kHz)
+REFA AND -REFA	+REFB AND -REFB	+REFC AND -REFC	REF				LT6375A	LT6375	LT6375A	LT6375	
19k	38k	23.75k	190k				LT6375A	LT6375	LT6375A	LT6375	
OPEN	GND	OPEN	REF	7	1	250	300	450	9	12	575
OPEN	OPEN	GND	REF	10	1	307	380	600	12	16	530
GND	OPEN	OPEN	REF	12	1	346	450	720	14	19	485
OPEN	GND	GND	REF	15	1	410	540	900	16	22	445
GND	GND	OPEN	REF	17	1	445	600	1000	19	25	405
GND	OPEN	GND	REF	20	1	508	700	1200	23	30	375
GND	GND	GND	REF	25	1	599	900	1500	28	37	310

+REFC, -REFC) result in different resistor divider ratios (DIV) and different attenuation of the LT6375's input common mode voltage.

The internal op amp of LT6375 has two operating regions: a) If the common mode voltage at the inputs of the internal op amp (V_{CMOP}) is between V^- and $V^+ - 1.75\text{V}$, the op amp operates in its normal region; b) If V_{CMOP} is between $V^+ - 1.75\text{V}$ and $V^- + 76\text{mV}$, the op amp continues to operate, but in its Over-The-Top region with degraded performance (see Over-The-Top operation section of this data sheet for more detail).

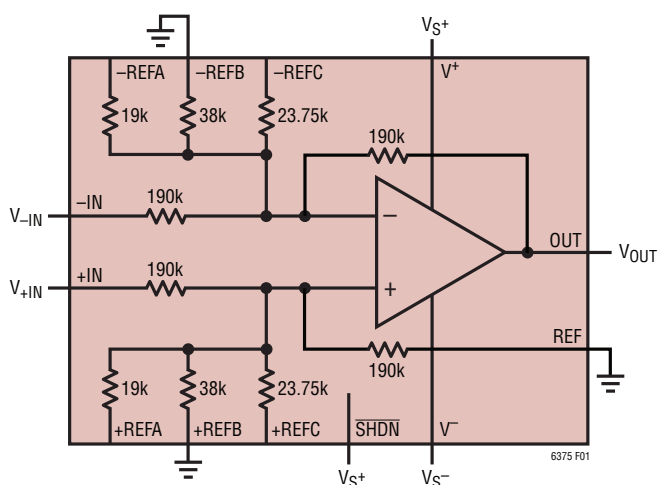

Figure 1. Basic Connections for Dual-Supply Operation (Resistor Divider Ratio = 7)

Table 2 lists the valid input common mode voltage range for an LT6375 with different configurations of the reference pins when used with dual power supplies. Using the voltage ranges in this table ensures that the internal op amp is operating in its normal (and best) region. The figure entitled Common Mode Voltage Range vs Power Supply Voltage, in the Typical Performance Characteristics section of this data sheet, illustrates the information in Table 2 graphically.

Table 3 lists the valid input common mode voltage range for an LT6375 that results in the internal op amp operating in its Over-The-Top region.

The reference pins can be connected to ground (as in Tables 2 and 3) or to any reference voltage. In order to achieve the specified gain accuracy and CMRR performance of the LT6375, this reference must have a very low impedance. The valid input common mode range changes depending on the voltages chosen for reference pins. One positive and one negative reference should always be connected to a low impedance voltage to ensure the stability of the amplifier. Table 4 lists the valid input common mode voltage range for an LT6375 when the part is used with a single power supply, and REF and the other reference pins are connected to mid-supply. If, as shown in Table 5, the REF pin remains connected to mid-supply, while the other reference pins are connected to ground, the result is a higher positive input range at the expense of a more restricted negative input range.

APPLICATIONS INFORMATION

Table 2. Common Mode Voltage Operating Range with Dual Power Supplies (Normal Region)

INPUT RANGE (REF = GND)									
+REFA AND -REFA	+REFB AND -REFB	+REFC AND -REFC	DIV	$V_S = \pm 2.5V$		$V_S = \pm 15V$		$V_S = \pm 25V$	
				HIGH	LOW	HIGH	LOW	HIGH	LOW
OPEN	GND	OPEN	7	5.25	-17.5	92.75	-105	162.75	-175
OPEN	OPEN	GND	10	7.5	-25	132.5	-150	232.5	-250
GND	OPEN	OPEN	12	9	-30	159	-180	270	-270
OPEN	GND	GND	15	11.25	-37.5	198.75	-225	270	-270
GND	GND	OPEN	17	12.75	-42.5	225.25	-255	270	-270
GND	OPEN	GND	20	15	-50	265	-270	270	-270
GND	GND	GND	25	18.75	-62.5	270	-270	270	-270

Table 3. Common Mode Voltage Operating Range with Dual Power Supplies (Over-The-Top Region)

INPUT RANGE (REF = GND)									
+REFA AND -REFA	+REFB AND -REFB	+REFC AND -REFC	DIV	$V_S = \pm 2.5V$		$V_S = \pm 15V$		$V_S = \pm 25V$	
				HIGH	LOW	HIGH	LOW	HIGH	LOW
OPEN	GND	OPEN	7	270	-17.5	270	-105	270	-175
OPEN	OPEN	GND	10	270	-25	270	-150	270	-250
GND	OPEN	OPEN	12	270	-30	270	-180	270	-270
OPEN	GND	GND	15	270	-37.5	270	-225	270	-270
GND	GND	OPEN	17	270	-42.5	270	-255	270	-270
GND	OPEN	GND	20	270	-50	270	-270	270	-270
GND	GND	GND	25	270	-62.5	270	-270	270	-270

Table 4. Common Mode Voltage Operating Range with a Single Power Supply, References to Mid-Supply (Normal Region)

INPUT RANGE (REF = $V_S/2$)									
+REFA AND -REFA	+REFB AND -REFB	+REFC AND -REFC	DIV	$V_S = 5V$		$V_S = 30V$		$V_S = 50V$	
				HIGH	LOW	HIGH	LOW	HIGH	LOW
OPEN	$V_S/2$	OPEN	7	7.75	-15	107.75	-90	187.75	-150
OPEN	OPEN	$V_S/2$	10	10	-22.5	147.5	-135	257.5	-225
$V_S/2$	OPEN	OPEN	12	11.5	-27.5	174	-165	270	-270
OPEN	$V_S/2$	$V_S/2$	15	13.75	-35	213.75	-210	270	-270
$V_S/2$	$V_S/2$	OPEN	17	15.25	-40	240.25	-240	270	-270
$V_S/2$	OPEN	$V_S/2$	20	17.5	-47.5	270	-270	270	-270
$V_S/2$	$V_S/2$	$V_S/2$	25	21.25	-60	270	-270	270	-270

Table 5. Common Mode Voltage Operating Range with a Single Power Supply, References to GND (Normal Region)

INPUT RANGE (REF = $V_S/2$)									
+REFA AND -REFA	+REFB AND -REFB	+REFC AND -REFC	DIV	$V_S = 5V$		$V_S = 30V$		$V_S = 50V$	
				HIGH	LOW	HIGH	LOW	HIGH	LOW
OPEN	GND	OPEN	7	20.25	-2.5	182.75	-15	270	-25
OPEN	OPEN	GND	10	30	-2.5	267.5	-15	270	-25
GND	OPEN	OPEN	12	36.5	-2.5	270	-15	270	-25
OPEN	GND	GND	15	46.25	-2.5	270	-15	270	-25
GND	GND	OPEN	17	52.75	-2.5	270	-15	270	-25
GND	OPEN	GND	20	62.5	-2.5	270	-15	270	-25
GND	GND	GND	25	78.75	-2.5	270	-15	270	-25

The LT6375 will not operate correctly if the common mode voltage at its input pins goes below the range specified in above tables, but the part will not be damaged as long as the lowest common mode voltage at the inputs of the internal op amp (V_{CMOP}) remains between $V^- - 25V$ and V^- . Also, the voltage at LT6375 input pins should never be higher than 270V or lower than -270V under any circumstances.

SHUTDOWN

The LT6375 in the DFN14 package has a shutdown pin (SHDN). Under normal operation this pin should be tied to V^+ or allowed to float. Tying this pin to 2.5V below V^+ will cause the part to enter a low power state. The supply current is reduced to less than 25 μ A and the op amp output becomes high impedance.

SUPPLY VOLTAGE

The positive supply pin of the LT6375 should be bypassed with a small capacitor (typically 0.1 μ F) as close to the supply pin as possible. When driving heavy loads an additional 4.7 μ F electrolytic capacitor should be added. When using split supplies, the same is true for the V^- supply pin.

APPLICATIONS INFORMATION

ACCURATE CURRENT MEASUREMENTS

The LT6375 can be used in high side, low side and bi-directional wide common mode range current sensing. Figure 2 shows the LT6375 sensing current by measuring the voltage across R_{SENSE} . The added sense resistors create a CMRR error and a gain error. For R_{SENSE} greater than 2Ω the source resistance mismatch degrades the CMRR. Adding a resistor equal in value to R_{SENSE} in series with the +IN terminal (R_C) eliminates this mismatch.

Using an R_{SENSE} greater than 10Ω will cause the gain error to exceed the 0.006% specification of LT6375. This is due to the loading effects of the LT6375.

$$V_{OUT} = I_{LOAD} \cdot R_{SENSE} \cdot 190k / (190k + R_{SENSE})$$

Increasing R_{SENSE} and R_C slightly to R_{SENSE}' removes the gain error.

$$R_{SENSE}' = R_{SENSE} \cdot 190k / (190k - R_{SENSE})$$

NOISE AND FILTERING

The noise performance of the LT6375 can be optimized both by appropriate choice of its internal attenuation setting and by the addition of a filter to the amplifier output (Figure 3). For applications that do not require the full bandwidth of the LT6375, the addition of an output filter will lower system noise. Table 6 shows the output noise for different internal resistor divider ratios and output filter bandwidths.

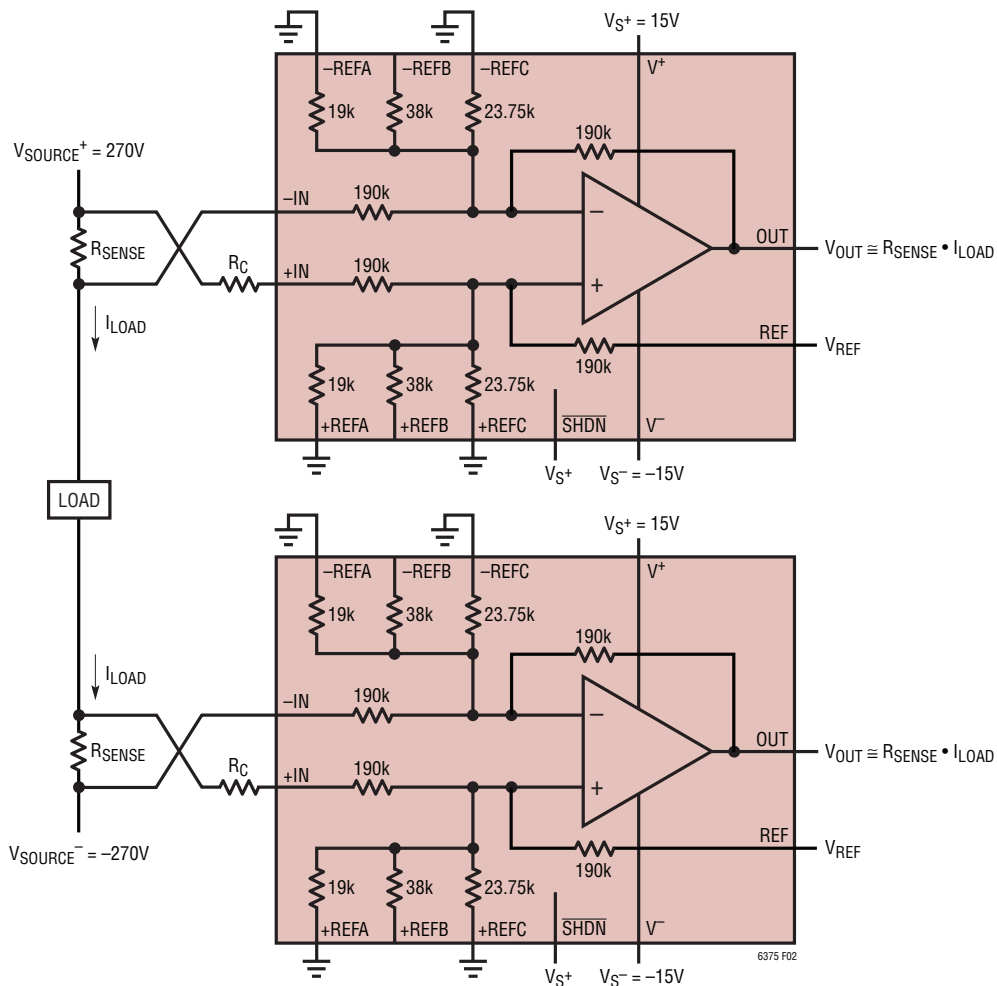

Figure 2. Wide Voltage Range Current Sensing

APPLICATIONS INFORMATION

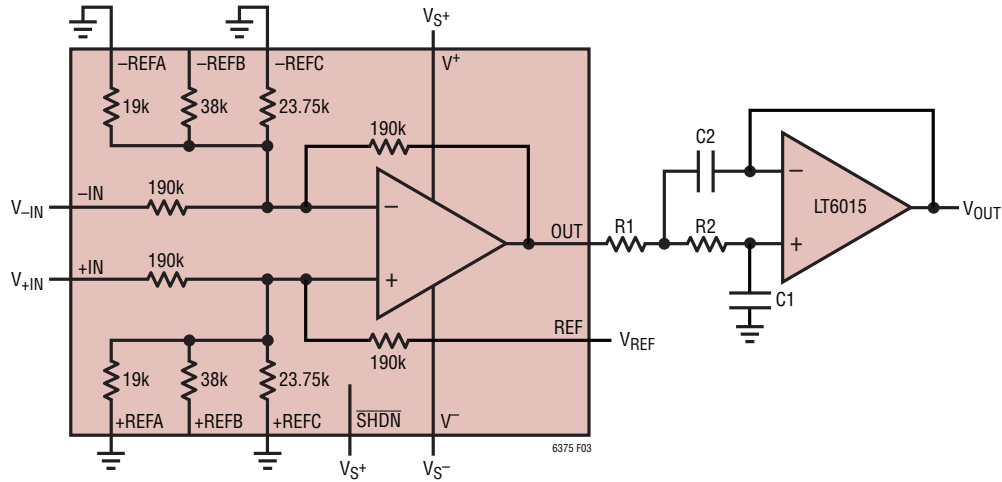

Figure 3. Output Filtering with 2-Pole Butterworth Filter

Table 6. Output Noise (V_{p-p}) for 2-Pole Butterworth Filter for Different Internal Resistor Divider Ratios

Corner Frequency	7	10	12	15	17	20	25
No Filter	1705 μ V	1831 μ V	1901 μ V	2008 μ V	2073 μ V	2177 μ V	2330 μ V
100kHz	537 μ V	662 μ V	740 μ V	853 μ V	925 μ V	1030 μ V	1197 μ V
10kHz	169 μ V	210 μ V	236 μ V	274 μ V	298 μ V	334 μ V	393 μ V
1kHz	54 μ V	67 μ V	75 μ V	87 μ V	95 μ V	107 μ V	126 μ V
100Hz	18 μ V	22 μ V	25 μ V	29 μ V	32 μ V	36 μ V	43 μ V

Table 7. Component Values for Different 2-Pole Butterworth Filter Bandwidths

Corner Frequency	R1	R2	C1	C2
100kHz	11k Ω	11.3k Ω	100pF	200pF
10kHz	11k Ω	11.3k Ω	1nF	2nF
1kHz	11k Ω	11.3k Ω	10nF	20nF
100Hz	11k Ω	11.3k Ω	0.1 μ F	0.2 μ F

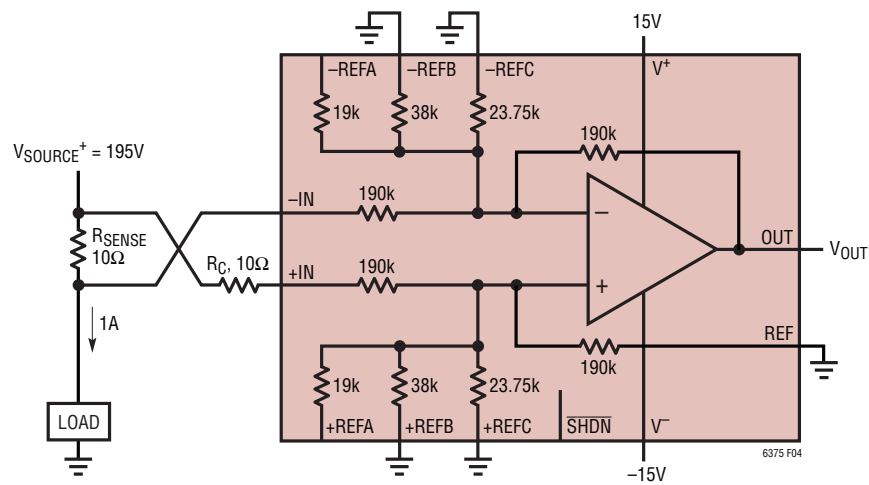

Figure 4. Current Measurement Application

APPLICATIONS INFORMATION

ERROR BUDGET ANALYSIS

Figure 4 shows the LT6375 in a current measurement application. The error budget for this application is shown in Table 8. The resistor divider ratio is set to 15 to divide the 195V input common mode voltage down to 13V at the op amp inputs. The 1A current and 10Ω sense resistor produce an output full-scale voltage of 10V. Table 8 shows the error sources in parts per million (ppm) of the full-scale voltage across the temperature range of 25°C to 85°C.

Different sources of error contribute to the maximum accuracy that can be achieved in an application. Gain error, offset voltage and common mode rejection error combine to set the initial error. Additionally, the gain error and offset voltage drift across the temperature range. The excellent gain accuracy, low offset voltage, high CMRR, low offset voltage drift and low gain error drift of the LT6375 all combine to enable extremely accurate measurements.

Over-The-Top OPERATION

When the input common mode voltage of the internal op amp (V_{CMOP}) in the LT6375 is biased near or above the V^+ supply, the op amp is operating in the Over-The-Top region. The op amp continues to operate with an input common mode voltage of up to 76V above V^- (regardless of the positive power supply voltage V^+), but its performance is

degraded. The op amp's input bias currents change from under $\pm 2nA$ to $14\mu A$. The op amp's input offset current rises to $\pm 50nA$ which adds $\pm 9.5mV$ to the output offset voltage.

In addition, when operating in the Over-The-Top region, the differential input impedance decreases from $1M\Omega$ in normal operation to approximately $3.7k\Omega$ in Over-The-Top operation. This resistance appears across the summing nodes of the internal op amp and boosts noise and offset while decreasing speed. Noise and offset will increase by between 66% and 83% depending on the resistor divider ratio setting. The bandwidth will be reduced by 40% to 45%. For more detail on Over-The-Top operation, consult the LT6015 data sheet.

OUTPUT

The output of the LT6375 can typically swing to within 5mV of either rail with no load and is capable of sourcing and sinking approximately 25mA. The LT6375 is internally compensated to drive at least 1nF of capacitance under any output loading conditions. For larger capacitive loads, a 0.22μF capacitor in series with a 150Ω resistor between the output and ground will compensate the amplifier to drive capacitive loads greater than 1nF. Additionally, the LT6375 has more gain and phase margin as the resistor divider ratio is increased.

Table 8. Error Budget Analysis

ERROR SOURCE	LT6375A	LT6375	COMPETITOR 1	COMPETITOR 2	ERROR, ppm of FS			
					LT6375A	LT6375	COMPETITOR 1	COMPETITOR 2
Accuracy, $T_A = 25^\circ C$								
Initial Gain Error	0.0035% FS	0.006% FS	0.02% FS	0.03% FS	35	60	200	300
Offset Voltage	540μV	900μV	1100μV	500μV	54	90	110	50
Common Mode	195V/96dB = 3090μV	195V/89dB = 6920μV	195V/90dB = 6166μV	195V/86dB = 9770μV	309	692	617	977
Total Accuracy Error					398	842	927	1327
Temperature Drift								
Gain	1ppm/°C ×60°C	1ppm/°C ×60°C	10ppm/°C ×60°C	10ppm/°C ×60°C	60	60	600	600
Offset Voltage	16μV/°C ×60°C	22μV/°C ×60°C	15μV/°C ×60°C	10μV/°C ×60°C	96	132	90	60
Total Drift Error					156	192	690	660
Total Error					554	1034	1617	1987

APPLICATIONS INFORMATION

Assuming a thermal resistance of 43°C/W, the die temperature will experience a 34°C rise above ambient. This implies that the maximum ambient temperature the LT6375 should operate under the above conditions is:

$$T_A = 150^\circ\text{C} - 34^\circ\text{C} = 116^\circ\text{C}$$

Keep in mind that the DFN package has an exposed pad which can be used to lower the θ_{JA} of the package. The more PCB metal connected to the exposed pad, the lower the thermal resistance.

The MSOP package has no exposed pad and a higher thermal resistance ($\theta_{JA} = 130^\circ\text{C}/\text{W}$). It should not be used in applications which have a high ambient temperature, require driving a heavy load, or require an extreme input voltage.

THERMAL SHUTDOWN

For safety, the LT6375 will enter shutdown mode when the die temperature rises to approximately 163°C. This thermal shutdown has approximately 9°C of hysteresis requiring the die temperature to cool 9°C before enabling the amplifier again.

USE AT OTHER PRECISION DC GAINS

The array of resistors within the LT6375 provides numerous configurable connections that provide precision gains other than the unity differential gain options described previously. Note that only the +IN and –IN pins can operate outside of the supply window. Since most of these alternate configurations involve driving the REF_x pins, as well as the +IN and –IN pins, the input signals must be less than the supply voltages. Fully differential gains are available as shown in Table 9, and may be output-shifted with a REF offset signal. These configurations allow the LT6375 to be used as a versatile precision gain block with essentially no external components besides the supply decoupling. In most cases, only a single positive supply will be required. In Table 9, connections are identified as NC (no connect), INPUT (refers to both inputs driven, +signal to +pins, –signal to –pins), CROSS (refers to inputs cross-coupled, +signal to –pins, –signal to +pins), OUT (refers to the output fed back to –pins), or REF (refers to

connecting the REF pin to +pins). The same configurations provide inverting gains by grounding any pins intended for the +signal source. The differential input resistance is also tabulated as well as the amplification factor of the internal gain section involved (noise-gain, which helps to estimate the error-budget of the configuration).

Single-ended noninverting gains are also available as shown in Table 10, including many that operate as buffers (loaded only by the op amp input bias). A rich option set exists by using the REF pin as an additional variable. Two attenuation options exist that can accept signals outside the power supply range since they only drive the +IN pin. In Table 10, connections are identified as NC (no connect), INPUT (driven by the input), OUT (fed back from the output), or GROUND (grounded). Table 10 also includes tabulations of the internal resistor divider (DIV), noise gain (re-amplification), and the input loading presented by the circuit.

USE AS PRECISION AC GAIN BLOCK

In AC-coupled applications operating from a single power supply, it is useful to set the output voltage at mid-supply to maximize dynamic range. The LT6375 readily supports this with no additional biasing components by connecting specific pins to the V^+ and V^- potentials and AC-coupling the signal paths. Table 11 shows the available inverting gains and also tabulates the load resistances presented at the input. In Table 11, connections are identified as NC (no connect), AC IN (AC-coupled to the input) OUT (fed back from the output), tied to V^+ , tied to V^- , or AC GND (AC-grounded). All pins that require an AC ground can share a single bypass capacitor. Likewise, all pins driven from the source signal may share a coupling capacitor as well. The output should also connect to the load circuitry using a coupling capacitor to block the mid-supply DC voltage.

The LT6375 may also be used for single-supply noninverting AC gains by employing a combination of input attenuation and re-amplification. With numerous choices of attenuation and re-amplification, several hundred overall gain combinations are possible, ranging from 0.167 to 23. The combinations are more plentiful than the DC configurations because there is no constraint on matching internal source resistances to minimize offset.

APPLICATIONS INFORMATION

The input attenuator section dedicates some pins to establishing a mid-supply bias point and with the remaining pins, provides several choices of input signal division factors as shown in Table 12. The high attenuations that only use +IN for the signal path can accept waveform peaks that significantly exceed the supply range. Table 12 also includes tabulations of the resulting AC load resistance presented to the signal source. Here again, all pins that require an AC-ground connection may share a single bypass capacitor, and all AC signal connections may share

a coupling capacitor. Note that configurations with +IN to V+ will bias at 50% of supply, while the others shown will bias at 38% of supply.

The single-supply AC-coupled noninverting circuit is completed by configuring the post-attenuator amplification factor. Table 13 shows the available re-amplification factors. Once again, all pins that require an AC-ground connection may share a single bypass capacitor, and the output should use a coupling capacitor to its load destination as well.

Table 9. Configurations for Precision Differential Gains Other Than Unity

LT6375 DIFFERENTIAL AND INVERTING PRECISION DC GAINS

GAIN	±IN	±REFA	±REFB	±REFC	REF	DIFF R _{IN} (k)	NOISE GAIN
0.167	CROSS	INPUT	OUT/REF	CROSS	REF	20	4.2
0.333	NC	INPUT	OUT/REF	CROSS	REF	21	4.0
0.5	INPUT	INPUT	OUT/REF	CROSS	REF	20	4.2
1.5	OUT/REF	NC	CROSS	INPUT	REF	29	7.5
2	CROSS	NC	CROSS	INPUT	REF	27	15.0
2.5	OUT/REF	INPUT	CROSS	NC	REF	25	8.5
2.833	CROSS	INPUT	OUT/REF	INPUT	REF	20	4.2
3	NC	INPUT	OUT/REF	INPUT	REF	21	4.0
3.167	INPUT	INPUT	OUT/REF	INPUT	REF	20	4.2
3.5	OUT/REF	INPUT	INPUT	CROSS	REF	17	12.5
4	CROSS	NC	INPUT	NC	REF	63	7.0
5	NC	NC	INPUT	NC	REF	76	6.0
6	INPUT	NC	INPUT	NC	REF	63	7.0
7	CROSS	NC	NC	INPUT	REF	42	10.0
8	NC	NC	NC	INPUT	REF	48	9.0
9	INPUT	NC	NC	INPUT	REF	42	10.0
10	NC	INPUT	NC	NC	REF	38	11.0
11	INPUT	INPUT	NC	NC	REF	35	12.0
12	CROSS	NC	INPUT	INPUT	REF	27	15.0
13	NC	NC	INPUT	INPUT	REF	29	14.0
14	INPUT	NC	INPUT	INPUT	REF	27	15.0
15	NC	INPUT	INPUT	NC	REF	25	16.0
16	INPUT	INPUT	INPUT	NC	REF	24	17.0
17	CROSS	INPUT	NC	INPUT	REF	20	20.0
18	NC	INPUT	NC	INPUT	REF	21	19.0
19	INPUT	INPUT	NC	INPUT	REF	20	20.0
22	CROSS	INPUT	INPUT	INPUT	REF	16	25.0
23	NC	INPUT	INPUT	INPUT	REF	17	24.0
24	INPUT	INPUT	INPUT	INPUT	REF	16	25.0

APPLICATIONS INFORMATION

Table 10. Configurations for Precision Noninverting Gains
LT6375 NONINVERTING PRECISION DC GAINS

GAIN	FEATURE	+IN	+REFA	+REFB	+REFC	REF	-IN	-REFA	-REFB	-REFC	NOISE GAIN	DIV	R _{IN} (k)
0.167	Wide Input	INPUT	GROUND	GROUND	GROUND	GROUND	GROUND	GROUND	OUT	GROUND	4.167	25	198
0.333		INPUT	GROUND	GROUND	GROUND	INPUT	GROUND	GROUND	OUT	GROUND	4.167	12.5	103
0.5	Wide Input	INPUT	NC	NC	GROUND	GROUND	OUT	NC	NC	GROUND	5	10	302
0.833		NC	GROUND	INPUT	GROUND	GROUND	NC	GROUND	OUT	GROUND	4	4.8	48
1		INPUT	NC	NC	GROUND	INPUT	OUT	NC	NC	GROUND	5	5	170
1.167		INPUT	GROUND	INPUT	GROUND	INPUT	GROUND	GROUND	OUT	GROUND	4.167	3.571	38
1.333		GROUND	GROUND	GROUND	INPUT	NC	NC	GROUND	OUT	GROUND	4	3	36
1.5		NC	GROUND	GROUND	INPUT	INPUT	NC	GROUND	OUT	GROUND	4	2.667	34
1.667		NC	INPUT	GROUND	GROUND	GROUND	NC	GROUND	OUT	GROUND	4	2.400	33
1.833		INPUT	INPUT	GROUND	GROUND	NC	NC	GROUND	OUT	GROUND	4	2.182	32
2		INPUT	NC	GROUND	NC	INPUT	GROUND	NC	GROUND	NC	7	3.500	37
2.167		GROUND	GROUND	INPUT	INPUT	NC	NC	GROUND	OUT	GROUND	4	1.846	32
2.333		INPUT	GROUND	INPUT	INPUT	NC	NC	GROUND	OUT	GROUND	4	1.714	33
2.5		NC	GROUND	INPUT	NC	NC	OUT	NC	GROUND	GROUND	7.5	3	57
2.667		INPUT	INPUT	INPUT	GROUND	NC	NC	GROUND	OUT	GROUND	4	1.500	36
2.833		INPUT	INPUT	INPUT	GROUND	INPUT	GROUND	GROUND	OUT	GROUND	4.167	1.471	35
3		INPUT	NC	INPUT	GROUND	GROUND	OUT	NC	GROUND	GROUND	7.5	2.500	53
3.167		INPUT	INPUT	GROUND	INPUT	NC	NC	GROUND	OUT	GROUND	4	1.263	48
3.333		INPUT	INPUT	GROUND	INPUT	INPUT	GROUND	GROUND	OUT	GROUND	4.167	1.250	47
3.5		INPUT	NC	INPUT	GROUND	INPUT	OUT	NC	GROUND	GROUND	7.5	2.143	51
3.833		GROUND	INPUT	INPUT	INPUT	GROUND	GROUND	GROUND	OUT	GROUND	4.167	1.087	103
4	Buffer	INPUT	INPUT	INPUT	INPUT	NC	NC	GROUND	OUT	GROUND	4	1	Hi-Z
4.167	Buffer	INPUT	INPUT	INPUT	INPUT	INPUT	GROUND	GROUND	OUT	GROUND	4.167	1	Hi-Z
4.5		INPUT	NC	NC	INPUT	GROUND	OUT	NC	NC	GROUND	5	1.111	302
5	Buffer	NC	INPUT	NC	NC	NC	OUT	NC	NC	GROUND	5	1	Hi-Z
5.5		INPUT	INPUT	NC	NC	GROUND	OUT	GROUND	NC	NC	6	1.091	226
6	Buffer	INPUT	NC	INPUT	NC	NC	NC	NC	GROUND	NC	6	1	Hi-Z
6.5		GROUND	NC	INPUT	INPUT	GROUND	OUT	NC	GROUND	GROUND	7.5	1.154	110
7	Buffer	INPUT	NC	INPUT	NC	INPUT	GROUND	NC	GROUND	NC	7	1	Hi-Z
7.5	Buffer	NC	INPUT	INPUT	NC	NC	OUT	NC	GROUND	GROUND	7.5	1	Hi-Z
8		NC	NC	NC	INPUT	GROUND	NC	NC	NC	GROUND	9	1.125	321
8.5	Buffer	NC	NC	NC	INPUT	GROUND	OUT	GROUND	GROUND	NC	8.5	1	Hi-Z
9	Buffer	INPUT	NC	NC	INPUT	NC	NC	NC	NC	GROUND	9	1	Hi-Z
9.5		INPUT	INPUT	NC	INPUT	GROUND	OUT	GROUND	NC	GROUND	10	1.053	200
10	Buffer	NC	INPUT	NC	NC	NC	GROUND	NC	NC	GROUND	10	1	Hi-Z
11	Buffer	INPUT	INPUT	NC	NC	NC	NC	GROUND	NC	NC	11	1	Hi-Z
11.5		GROUND	INPUT	INPUT	INPUT	GROUND	OUT	GROUND	GROUND	GROUND	12.5	1.087	103

APPLICATIONS INFORMATION

Table 10. Configurations for Precision Noninverting Gains

GAIN	FEATURE	+IN	+REFA	+REFB	+REFC	REF	-IN	-REFA	-REFB	-REFC	NOISE GAIN	DIV	R _{IN} (k)
12	Buffer	INPUT	INPUT	NC	NC	INPUT	GROUND	GROUND	NC	NC	12	1	Hi-Z
12.5	Buffer	INPUT	INPUT	INPUT	INPUT	INPUT	OUT	GROUND	GROUND	GROUND	12.5	1	Hi-Z
13		NC	NC	INPUT	INPUT	GROUND	NC	NC	GROUND	GROUND	14	1.077	205
14	Buffer	INPUT	NC	INPUT	INPUT	NC	NC	NC	GROUND	GROUND	14	1	Hi-Z
15	Buffer	NC	INPUT	INPUT	NC	NC	GROUND	NC	GROUND	GROUND	15	1	Hi-Z
16	Buffer	INPUT	INPUT	INPUT	NC	NC	NC	GROUND	GROUND	NC	16	1	Hi-Z
17	Buffer	NC	NC	NC	INPUT	GROUND	GROUND	GROUND	GROUND	NC	17	1	Hi-Z
18		NC	INPUT	NC	INPUT	GROUND	NC	GROUND	NC	GROUND	19	1.056	201
19	Buffer	INPUT	INPUT	NC	INPUT	NC	NC	GROUND	NC	GROUND	19	1	Hi-Z
20	Buffer	INPUT	INPUT	NC	INPUT	INPUT	GROUND	GROUND	NC	GROUND	20	1	Hi-Z
23		NC	INPUT	INPUT	INPUT	GROUND	NC	GROUND	GROUND	GROUND	24	1.043	198
24	Buffer	INPUT	INPUT	INPUT	INPUT	NC	NC	GROUND	GROUND	GROUND	24	1	Hi-Z
25	Buffer	INPUT	INPUT	INPUT	INPUT	INPUT	GROUND	GROUND	GROUND	GROUND	25	1	Hi-Z

Table 11. Configurations for Single-Supply AC-Coupled Inverting Gains

LT6375 SINGLE-SUPPLY INVERTING AC GAINS

GAIN	-IN	-REFA	-REFB	-REFC	+IN	+REFA	+REFB	+REFC	REF	AC R _{IN} (k)
-3	NC	AC IN	OUT	AC IN	V ⁺	AC GND	AC GND	AC GND	V ⁻	11
-3.167	AC IN	AC IN	OUT	AC IN	V ⁺	AC GND	AC GND	AC GND	V ⁻	10
-5	NC	NC	AC IN	NC	V ⁺	AC GND	AC GND	AC GND	V ⁻	38
-6	AC IN	NC	AC IN	NC	V ⁺	AC GND	AC GND	AC GND	V ⁻	32
-8	NC	NC	NC	AC IN	V ⁺	AC GND	AC GND	AC GND	V ⁻	24
-9	AC IN	NC	NC	AC IN	V ⁺	AC GND	AC GND	AC GND	V ⁻	21
-10	NC	AC IN	NC	NC	V ⁺	AC GND	AC GND	AC GND	V ⁻	19
-11	AC IN	AC IN	NC	NC	V ⁺	AC GND	AC GND	AC GND	V ⁻	17
-13	NC	NC	AC IN	AC IN	V ⁺	AC GND	AC GND	AC GND	V ⁻	15
-14	AC IN	NC	AC IN	AC IN	V ⁺	AC GND	AC GND	AC GND	V ⁻	14
-15	NC	AC IN	AC IN	NC	V ⁺	AC GND	AC GND	AC GND	V ⁻	13
-16	AC IN	AC IN	AC IN	NC	V ⁺	AC GND	AC GND	AC GND	V ⁻	12
-18	NC	AC IN	NC	AC IN	V ⁺	AC GND	AC GND	AC GND	V ⁻	11
-19	AC IN	AC IN	NC	AC IN	V ⁺	AC GND	AC GND	AC GND	V ⁻	10
-23	NC	AC IN	AC IN	AC IN	V ⁺	AC GND	AC GND	AC GND	V ⁻	8
-24	AC IN	AC IN	AC IN	AC IN	V ⁺	AC GND	AC GND	AC GND	V ⁻	8

APPLICATIONS INFORMATION

Table 12. Configurations for Single-Supply AC-Coupled Input Attenuations

LT6375 SINGLE-SUPPLY AC ATTENUATOR CONFIGURATIONS

DIV	+IN	+REFA	+REFB	+REFC	REF	AC R _{IN} (k)
1.087	V ⁺	AC IN	AC IN	AC IN	V ⁻	103
1.111	V ⁺	AC IN	NC	AC IN	V ⁻	106
1.133	V ⁺	AC IN	AC IN	NC	V ⁻	108
1.154	V ⁺	NC	AC IN	AC IN	V ⁻	110
1.2	V ⁺	AC IN	NC	NC	V ⁻	114
1.25	V ⁺	NC	NC	AC IN	V ⁻	119
1.389	V ⁺	AC IN	AC GND	AC IN	V ⁻	38
1.4	V ⁺	NC	AC IN	NC	V ⁻	133
1.7	V ⁺	AC IN	AC GND	NC	V ⁻	46
1.875	V ⁺	NC	AC GND	AC IN	V ⁻	51
1.923	V ⁺	AC GND	AC IN	AC IN	V ⁻	30
2.083	AC IN	AC IN	V ⁺	V ⁻	AC IN	30
2.182	AC IN	AC IN	V ⁺	V ⁻	NC	32
2.273	AC IN	AC IN	V ⁺	V ⁻	AC GND	31
2.3	NC	AC IN	V ⁺	V ⁻	NC	34
2.4	NC	AC IN	V ⁺	V ⁻	AC GND	33
2.5	V ⁺	AC IN	AC GND	AC GND	V ⁻	32
3.125	V ⁺	AC GND	AC GND	AC IN	V ⁻	35
3.4	V ⁺	AC GND	AC IN	NC	V ⁻	54
5	V ⁺	AC GND	AC IN	AC GND	V ⁻	47
7.5	AC IN	NC	V ⁺	V ⁻	AC IN	110
12	AC IN	AC GND	V ⁺	V ⁻	AC IN	103
14	AC IN	NC	V ⁺	V ⁻	NC	205
15	AC IN	NC	V ⁺	V ⁻	AC GND	204
24	AC IN	AC GND	V ⁺	V ⁻	NC	198
25	AC IN	AC GND	V ⁺	V ⁻	AC GND	198

APPLICATIONS INFORMATION

Table 13. Configurations for Single-Supply AC-Coupled Re-Amplifications

LT6375 NONINVERTING AC RE-AMPLIFICATIONS

GAIN	-IN	-REFA	-REFB	-REFC
4	NC	AC GND	OUT	AC GND
4.167	AC GND	AC GND	OUT	AC GND
5	OUT	NC	NC	AC GND
6	NC	NC	AC GND	NC
7	AC GND	NC	AC GND	NC
7.5	OUT	NC	AC GND	AC GND
8.5	OUT	AC GND	AC GND	NC
9	NC	NC	NC	AC GND
10	AC GND	NC	NC	AC GND
11	NC	AC GND	NC	NC
12	AC GND	AC GND	NC	NC
12.5	OUT	AC GND	AC GND	AC GND
14	NC	NC	AC GND	AC GND
15	AC GND	NC	AC GND	AC GND
16	NC	AC GND	AC GND	NC
17	AC GND	AC GND	AC GND	NC
19	NC	AC GND	NC	AC GND
20	AC GND	AC GND	NC	AC GND
24	NC	AC GND	AC GND	AC GND
25	AC GND	AC GND	AC GND	AC GND

TYPICAL APPLICATIONS

Telecom Supply Monitor

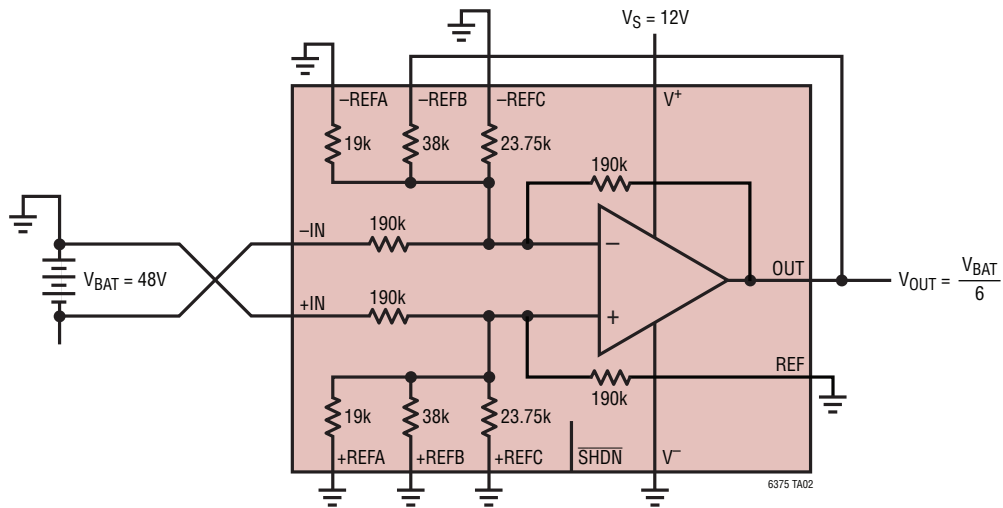

27dB Audio Gain Stage

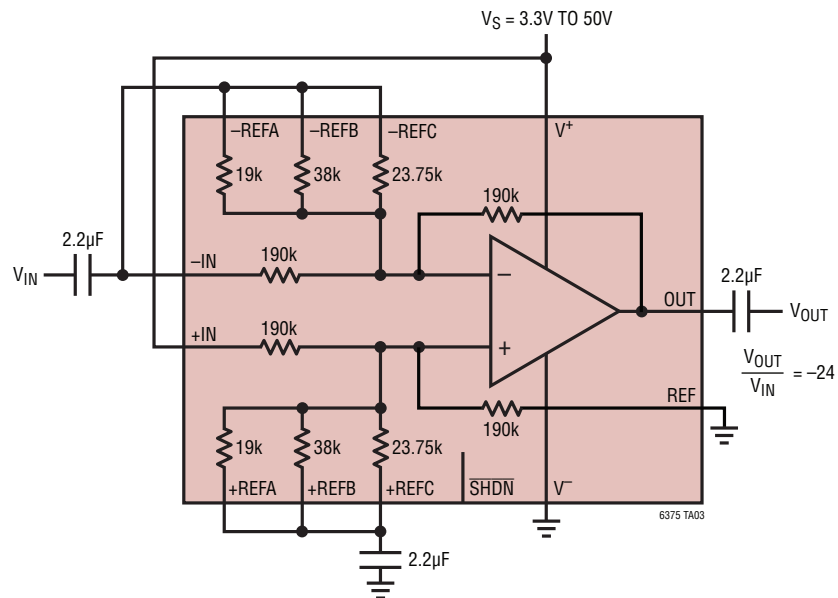

TYPICAL APPLICATIONS

±5mA Howland Current Source

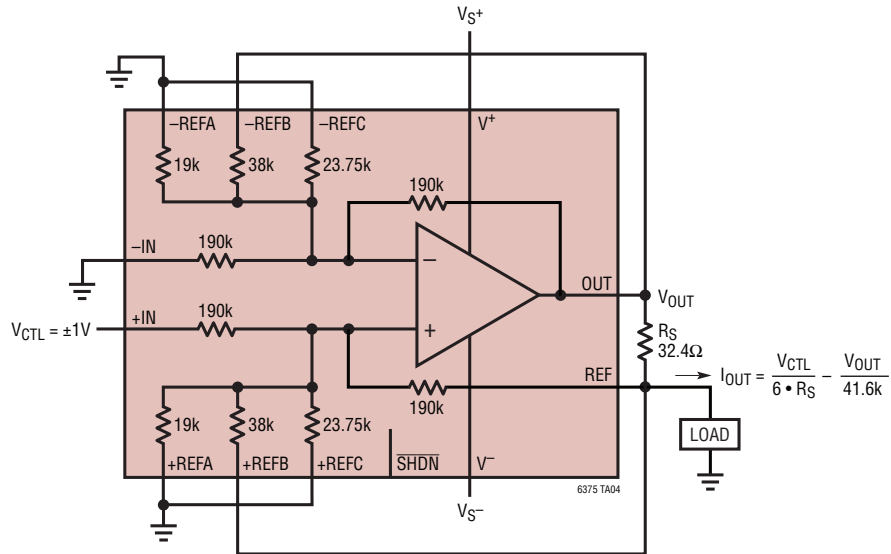

Precision Reference Divider/Buffer

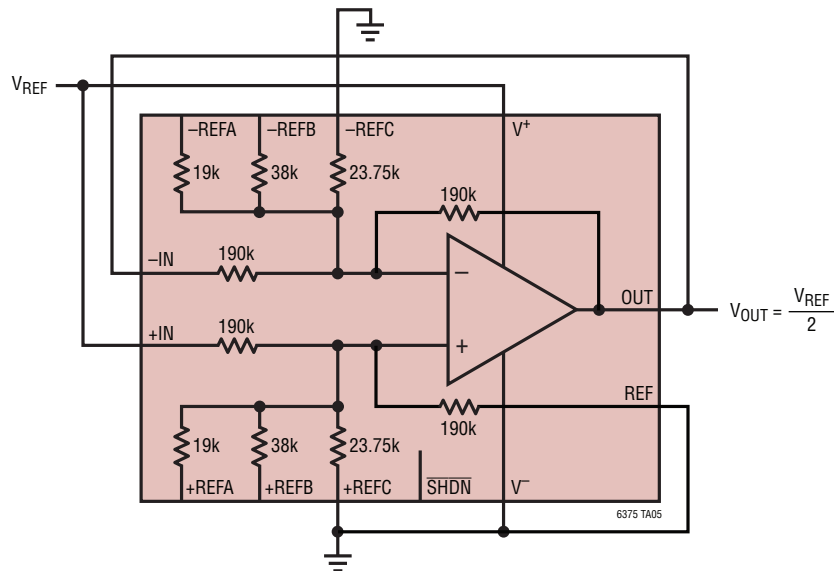

PACKAGE DESCRIPTION

Please refer to <http://www.linear.com/product/LT6375#packaging> for the most recent package drawings.

MS Package 16 (12)-Lead Plastic MSOP with 4 Pins Removed (Reference LTC DWG # 05-08-1847 Rev B)

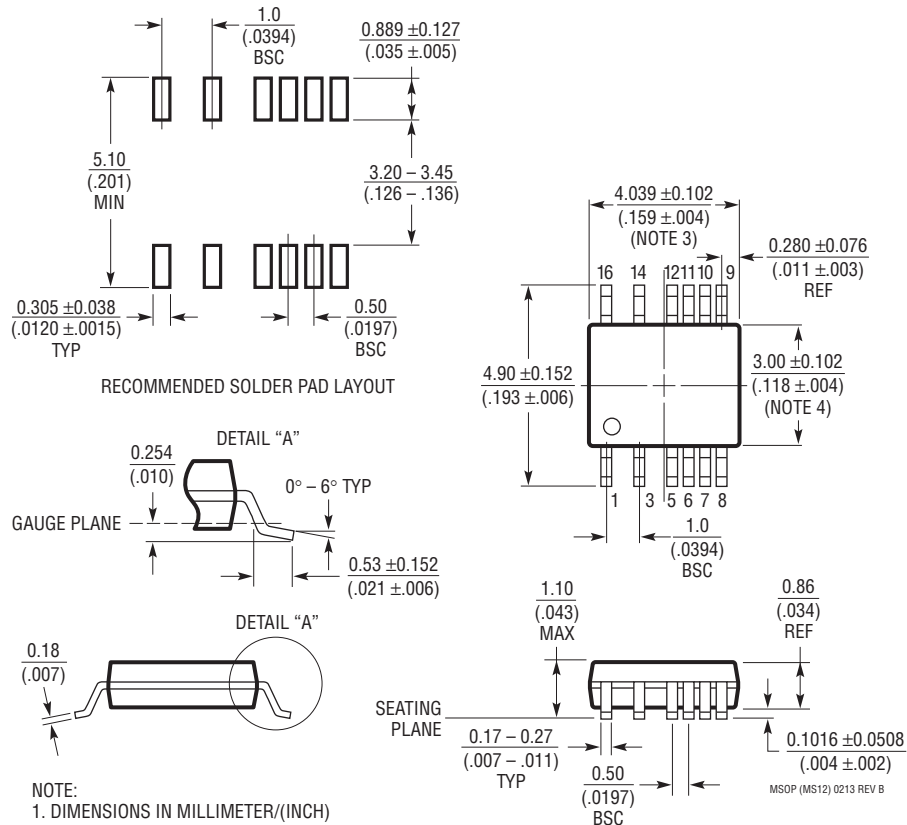

- NOTE:
1. DIMENSIONS IN MILLIMETER/(INCH)
 2. DRAWING NOT TO SCALE
 3. DIMENSION DOES NOT INCLUDE MOLD FLASH, PROTRUSIONS OR GATE BURRS.
MOLD FLASH, PROTRUSIONS OR GATE BURRS SHALL NOT EXCEED 0.152mm (.006") PER SIDE
 4. DIMENSION DOES NOT INCLUDE INTERLEAD FLASH OR PROTRUSIONS.
INTERLEAD FLASH OR PROTRUSIONS SHALL NOT EXCEED 0.152mm (.006") PER SIDE
 5. LEAD COPLANARITY (BOTTOM OF LEADS AFTER FORMING) SHALL BE 0.102mm (.004") MAX

MSOP (MS12) 0213 REV B

REVISION HISTORY

REV	DATE	DESCRIPTION	PAGE NUMBER
A	12/15	Added A-grade.	1-7, 15, 19

TYPICAL APPLICATION

Bidirectional Full Range Current Monitor

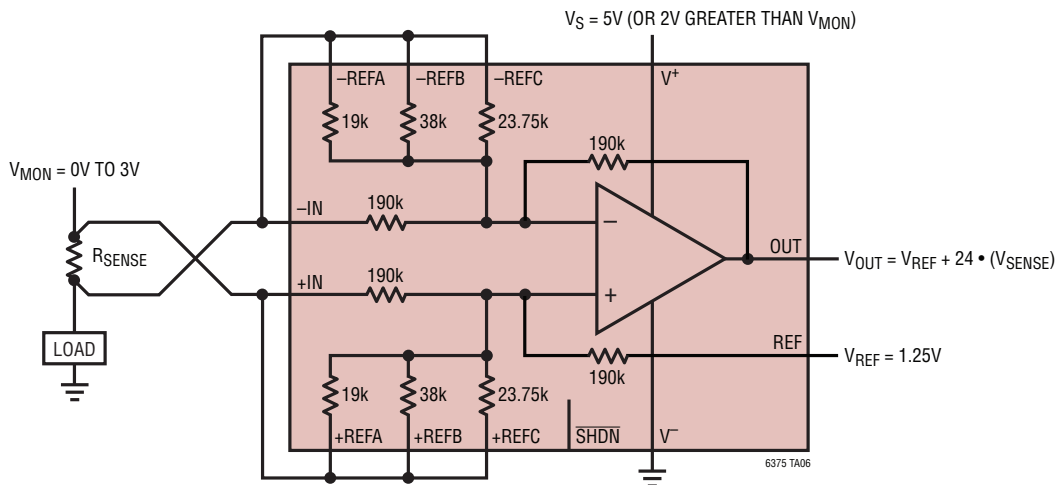

NOTE: OPERATES OVER FULL RANGE OF LOAD VOLTAGE

RELATED PARTS

PART NUMBER	DESCRIPTION	COMMENTS
LT1990	±250V Input Range Difference Amplifier	2.7V to 36V Operation, CMRR > 70dB, Input Voltage = ±250V
LT1991	Precision, 100µA Gain Selectable Amplifier	2.7V to 36V Operation, 50µV Offset, CMRR > 75B, Input Voltage = ±60V
LT1996	Precision, 100µA Gain Selectable Amplifier	Micropower, Pin Selectable Up to Gain = 118
LT1999	High Voltage, Bidirectional Current Sense Amplifier	-5V to 80V, 750 µV, CMRR 80dB 100kHz Gain: 10V/V, 20V/V, 50V/V
LT6015/LT6016/LT6017	Single, Dual, and Quad, Over-The-Top Precision Op Amp	3.2MHz, 0.8V/µs, 50µV V_{OS} , 3V to 50V V_S , 0.335mA I_S , RRIO
LTC6090	140V Operational Amplifier	50pA I_B , 1.6mV V_{OS} , 9.5V to 140V V_S , 4.5mA I_S , RR Output
LT6108	High Side Current Sense Amplifier with Reference and Comparator with Shutdown	2.7V to 60V, 125µV, Resistor Set Gain, ±1.25% Threshold Error
LT1787/LT1787HV	Precision, Bidirectional High Side Current Sense Amplifier	2.7V to 60V Operation, 75µV Offset, 60µA Current Draw
LTC6101/LTC6101HV	High Voltage High Side Current Sense Amplifier	4V to 60V/5V to 100V Operation, External Resistor Set Gain, SOT23
LTC6102/LTC6102HV	Zero Drift High Side Current Sense Amplifier	4V to 60V/5V to 100V Operation, ±10µV Offset, 1µs Step Response, MSOP8/DFN Packages
LTC6104	Bidirectional, High Side Current Sense	4V to 60V, Gain Configurable, 8-Pin MSOP Package

Looking for pricing, stock, or lifecycle information?

Click below to explore more details on WIN SOURCE:

 [View LT6375IMS#TRPBF on WIN SOURCE](#)

 [Analog Devices Inc. Information](#)

Optimize Your Supply Chain with WIN SOURCE Solutions

-  Global Sourcing Solution
-  Obsolete Management
-  Cost Control Management
-  Shortage Management
-  Alternative Solution
-  Excess Inventory Management