



**THE DATASHEET OF
LT1210XFE#TRPBF**



High Temperature 1.0A, 35MHz Current Feedback Amplifier

FEATURES

- Extreme High Temperature Operation: -40°C to 175°C
- 1.0A Minimum Output Drive Current
- 35MHz Bandwidth, $A_V = 2$, $R_L = 10\Omega$
- 900V/ μs Slew Rate, $A_V = 2$, $R_L = 10\Omega$
- High Input Impedance: $10\text{M}\Omega$
- Wide Supply Range: $\pm 5\text{V}$ to $\pm 15\text{V}$
- Shutdown Mode: $I_S < 200\mu\text{A}$
- Adjustable Supply Current
- Stable with $C_L = 10,000\text{pF}$
- Available as Dice
- Available in 16-Lead Thermally Enhanced TSSOP Package

APPLICATIONS

- Down-Hole Drilling and Instrumentation
- Heavy Industrial
- Avionics
- High Temperature Environments
- Cable Drivers
- Buffers
- Test Equipment Amplifiers
- Video Amplifiers
- ADSL Drivers

DESCRIPTION

The LT[®]1210X is a current feedback amplifier with high output current and excellent large-signal characteristics. The combination of high slew rate, 1.0A output drive and $\pm 15\text{V}$ operation enables the device to deliver significant power at frequencies in the 1MHz to 2MHz range. Short-circuit protection ensures the device's ruggedness. The LT1210X is stable with large capacitive loads, and can easily supply the large currents required by the capacitive loading. A shutdown feature switches the device into a high impedance and low supply current mode, reducing dissipation when the device is not in use. For lower bandwidth applications, the supply current can be reduced with a single external resistor.

The LT1210X is a member of a growing series of high temperature qualified products offered by Analog Devices. For a complete selection of high temperature products, please consult our website www.linear.com

The LT1210X is available in the thermally enhanced TSSOP16-E package for operation with supplies from $\pm 5\text{V}$ up to $\pm 15\text{V}$. The LT1210X is also available as dice.

All registered trademarks and trademarks are the property of their respective owners.

TYPICAL APPLICATION

Twisted Pair Driver

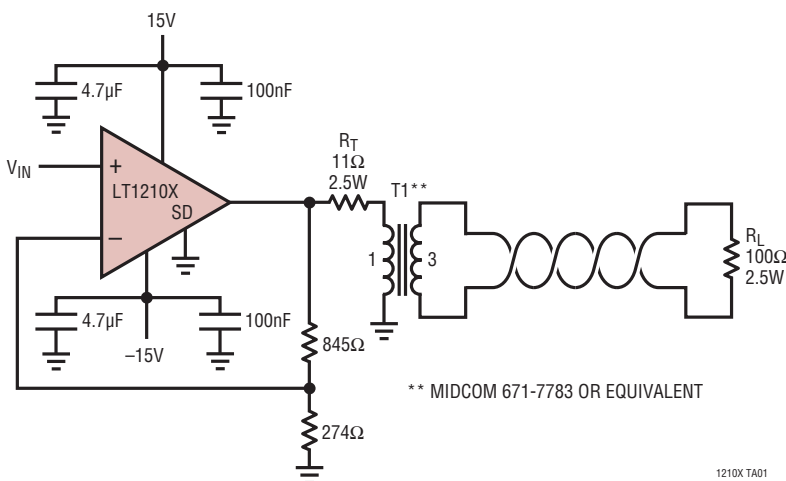

Total Harmonic Distortion vs Frequency

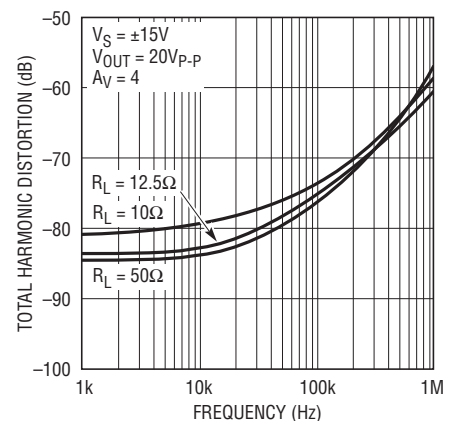

LT1210X

ABSOLUTE MAXIMUM RATINGS

(Note 1)

Supply Voltage	$\pm 18\text{V}$
Input Current.....	$\pm 15\text{mA}$
Output Short-Circuit Duration	
(Note 2)	Thermally Limited
Operating Temperature Range	
LT1210X.....	-40°C to 175°C
Junction Temperature	200°C
Storage Temperature Range	-65°C to 200°C
Lead Temperature (Soldering, 10 sec).....	300°C

PIN CONFIGURATION

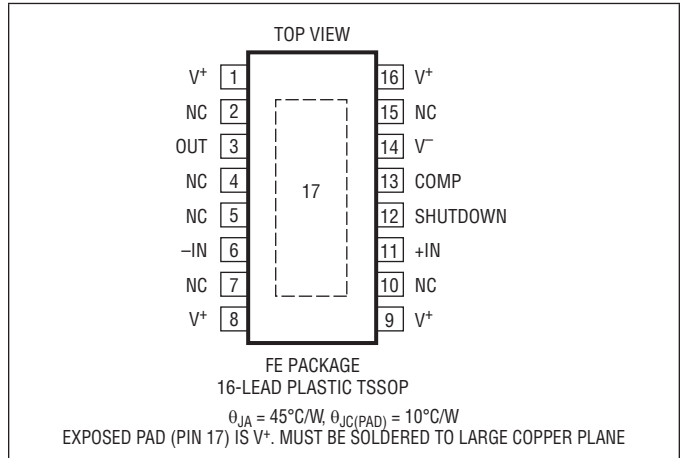

ORDER INFORMATION <http://www.linear.com/product/LT1210X#orderinfo>

TUBE	TAPE AND REEL	PART MARKING	PACKAGE DESCRIPTION	TEMPERATURE RANGE
LT1210XFE#PBF	LT1210XFE#TRPBF	1210XFE	16-Lead Plastic TSSOP	-40°C to 175°C

For more information on lead free part marking, go to: <http://www.linear.com/leadfree/>

For more information on tape and reel specifications, go to: <http://www.linear.com/tapeandreeel/>. Some packages are available in 500 unit reels through designated sales channels with #TRMPBF suffix.

ELECTRICAL CHARACTERISTICS

The ● denotes the specifications which apply over the full operating temperature range of -40°C to 175°C , otherwise specifications are at $T_A = 25^{\circ}\text{C}$. $V_{\text{CM}} = 0\text{V}$, $\pm 5\text{V} \leq V_S \leq \pm 15\text{V}$, pulse tested, $V_{\text{SD}} = 0\text{V}$, unless otherwise noted.

SYMBOL	PARAMETER	CONDITIONS	MIN	TYP	MAX	UNITS
V_{OS}	Input Offset Voltage			± 3	± 15 ± 20	mV mV
	Input Offset Voltage Drift			10		$\mu\text{V}/^{\circ}\text{C}$
I_{IN}^{+}	Noninverting Input Current			± 2	± 5 ± 20	μA μA
I_{IN}^{-}	Inverting Input Current			± 10	± 60 ± 100	μA μA
e_n	Input Noise Voltage Density	$f = 10\text{kHz}$, $R_F = 1\text{k}\Omega$, $R_G = 10\Omega$, $R_S = 0\Omega$		3.0		$\text{nV}/\sqrt{\text{Hz}}$
$+i_n$	Input Noise Current Density	$f = 10\text{kHz}$, $R_F = 1\text{k}\Omega$, $R_G = 10\Omega$, $R_S = 10\text{k}\Omega$		2.0		$\text{pA}/\sqrt{\text{Hz}}$
$-i_n$	Input Noise Current Density	$f = 10\text{kHz}$, $R_F = 1\text{k}\Omega$, $R_G = 10\Omega$, $R_S = 10\text{k}\Omega$		40		$\text{pA}/\sqrt{\text{Hz}}$
R_{IN}	Input Resistance	$V_{\text{IN}} = \pm 12\text{V}$, $V_S = \pm 15\text{V}$	●	1.50	10	M Ω
		$V_{\text{IN}} = \pm 2\text{V}$, $V_S = \pm 5\text{V}$	●	0.25	5	M Ω
C_{IN}	Input Capacitance	$V_S = \pm 15\text{V}$		2		pF
	Input Voltage Range	$V_S = \pm 15\text{V}$	●	± 12	± 13.5	V
		$V_S = \pm 5\text{V}$	●	± 2	± 3.5	V

1210Xfa

ELECTRICAL CHARACTERISTICS The ● denotes the specifications which apply over the full operating temperature range of -40°C to 175°C , otherwise specifications are at $T_A = 25^{\circ}\text{C}$. $V_{\text{CM}} = 0\text{V}$, $\pm 5\text{V} \leq V_S \leq \pm 15\text{V}$, pulse tested, $V_{\text{SD}} = 0\text{V}$, unless otherwise noted.

SYMBOL	PARAMETER	CONDITIONS	MIN	TYP	MAX	UNITS
CMRR	Common Mode Rejection Ratio	$V_S = \pm 15\text{V}$, $V_{\text{CM}} = \pm 12\text{V}$	● 55	62		dB
		$V_S = \pm 5\text{V}$, $V_{\text{CM}} = \pm 2\text{V}$	● 50	60		dB
	Inverting Input Current Common Mode Rejection	$V_S = \pm 15\text{V}$, $V_{\text{CM}} = \pm 12\text{V}$	●	0.1	10	$\mu\text{A/V}$
		$V_S = \pm 5\text{V}$, $V_{\text{CM}} = \pm 2\text{V}$	●	0.1	10	$\mu\text{A/V}$
PSRR	Power Supply Rejection Ratio	$V_S = \pm 5\text{V}$ to $\pm 15\text{V}$	● 60	77		dB
	Noninverting Input Current Power Supply Rejection	$V_S = \pm 5\text{V}$ to $\pm 15\text{V}$	●	30	500	nA/V
		$V_S = \pm 5\text{V}$ to $\pm 15\text{V}$	●	0.7	5	$\mu\text{A/V}$
A_V	Large-Signal Voltage Gain	$T_A = 25^{\circ}\text{C}$, $V_S = \pm 15\text{V}$, $V_{\text{OUT}} = \pm 10\text{V}$, $R_L = 10\Omega$		55	71	dB
		$V_S = \pm 15\text{V}$, $V_{\text{OUT}} = \pm 5.5\text{V}$, $R_L = 10\Omega$	●	45	68	dB
		$V_S = \pm 5\text{V}$, $V_{\text{OUT}} = \pm 2\text{V}$, $R_L = 10\Omega$	●	55	68	dB
R_{OL}	Transresistance, $\Delta V_{\text{OUT}}/\Delta I_{\text{IN}}^-$	$T_A = 25^{\circ}\text{C}$, $V_S = \pm 15\text{V}$, $V_{\text{OUT}} = \pm 10\text{V}$, $R_L = 10\Omega$		100	260	k Ω
		$V_S = \pm 15\text{V}$, $V_{\text{OUT}} = \pm 5.5\text{V}$, $R_L = 10\Omega$	●	24	200	k Ω
		$V_S = \pm 5\text{V}$, $V_{\text{OUT}} = \pm 2\text{V}$, $R_L = 10\Omega$	●	75	200	k Ω
V_{OUT}	Maximum Output Voltage Swing	$T_A = 25^{\circ}\text{C}$, $V_S = \pm 15\text{V}$, $R_L = 10\Omega$	● ± 10.0 ± 8.5	± 11.5		V V
		$T_A = 25^{\circ}\text{C}$, $V_S = \pm 5\text{V}$, $R_L = 10\Omega$	● ± 2.5 ± 2.0	± 3.0		V V
I_{OUT}	Maximum Output Current	$V_S = \pm 15\text{V}$, $R_L = 1\Omega$	● 1.0	2.0		A
I_S	Supply Current	$T_A = 25^{\circ}\text{C}$, $V_S = \pm 15\text{V}$, $V_{\text{SD}} = 0\text{V}$	●	35	50 65	mA mA
		Supply Current, $R_{\text{SD}} = 51\text{k}$ (Note 3)		15	30	mA
	Positive Supply Current, Shutdown	$V_S = \pm 15\text{V}$, $V_{\text{SD}} = 15\text{V}$	●		200	μA
	Output Leakage Current, Shutdown	$V_S = \pm 15\text{V}$, $V_{\text{SD}} = 15\text{V}$	●		10	μA
SR	Slew Rate (Note 4)	$T_A = 25^{\circ}\text{C}$, $A_V = 2$, $R_L = 400\Omega$		400	900	V/ μs
		$T_A = 25^{\circ}\text{C}$, $A_V = 2$, $R_L = 10\Omega$			900	V/ μs
	Differential Gain (Note 5)	$V_S = \pm 15\text{V}$, $R_F = 750\Omega$, $R_G = 750\Omega$, $R_L = 15\Omega$			0.3	%
	Differential Phase (Note 5)	$V_S = \pm 15\text{V}$, $R_F = 750\Omega$, $R_G = 750\Omega$, $R_L = 15\Omega$			0.1	DEG
BW	Small-Signal Bandwidth	$A_V = 2$, $V_S = \pm 15\text{V}$, Peaking $\leq 1\text{dB}$, $R_F = R_G = 680\Omega$, $R_L = 100\Omega$			55	MHz
		$A_V = 2$, $V_S = \pm 15\text{V}$, Peaking $\leq 1\text{dB}$, $R_F = R_G = 576\Omega$, $R_L = 10\Omega$			35	MHz

Note 1: Stresses beyond those listed under Absolute Maximum Ratings may cause permanent damage to the device. Exposure to any Absolute Maximum Rating condition for extended periods may affect device reliability and lifetime.

Note 2: A heat sink may be required to keep the junction temperature below the Absolute Maximum rating. Applies to short circuits to ground only. A short circuit between the output and either supply may permanently damage the part when operated on supplies greater than $\pm 10\text{V}$.

Note 3: R_{SD} is connected between the Shutdown pin and ground.

Note 4: Slew rate is measured at $\pm 5\text{V}$ on a $\pm 10\text{V}$ output signal while operating on $\pm 15\text{V}$ supplies with $R_F = 1.5\text{k}\Omega$, $R_G = 1.5\text{k}\Omega$ and $R_L = 400\Omega$.

Note 5: NTSC composite video with an output level of 2V.

SMALL-SIGNAL BANDWIDTH

$R_{SD} = 0\Omega$, $I_S = 30\text{mA}$, $V_S = \pm 5\text{V}$, Peaking $\leq 1\text{dB}$

A_V	$R_L (\Omega)$	$R_F (\Omega)$	$R_G (\Omega)$	-3dB BW (MHz)
-1	150	549	549	52.5
	30	590	590	39.7
	10	619	619	26.5
1	150	604	-	53.5
	30	649	-	39.7
	10	619	-	27.4
2	150	562	562	51.8
	30	590	590	38.8
	10	576	576	27.4
10	150	392	43.2	48.4
	30	383	42.2	40.3
	10	215	23.7	36.0

$R_{SD} = 0\Omega$, $I_S = 35\text{mA}$, $V_S = \pm 15\text{V}$, Peaking $\leq 1\text{dB}$

A_V	$R_L (\Omega)$	$R_F (\Omega)$	$R_G (\Omega)$	-3dB BW (MHz)
-1	150	604	604	66.2
	30	649	649	48.4
	10	665	665	46.5
1	150	750	-	56.8
	30	866	-	35.4
	10	845	-	24.7
2	150	665	665	52.5
	30	715	715	38.9
	10	576	576	35.0
10	150	453	49.9	61.5
	30	432	47.5	43.1
	10	221	24.3	45.5

$R_{SD} = 7.5\text{k}\Omega$, $I_S = 15\text{mA}$, $V_S = \pm 5\text{V}$, Peaking $\leq 1\text{dB}$

A_V	$R_L (\Omega)$	$R_F (\Omega)$	$R_G (\Omega)$	-3dB BW (MHz)
-1	150	562	562	39.7
	30	619	619	28.9
	10	604	604	20.5
1	150	634	-	41.9
	30	681	-	29.7
	10	649	-	20.7
2	150	576	576	40.2
	30	604	604	29.6
	10	576	576	21.6
10	150	324	35.7	39.5
	30	324	35.7	32.3
	10	210	23.2	27.7

$R_{SD} = 47.5\text{k}\Omega$, $I_S = 18\text{mA}$, $V_S = \pm 15\text{V}$, Peaking $\leq 1\text{dB}$

A_V	$R_L (\Omega)$	$R_F (\Omega)$	$R_G (\Omega)$	-3dB BW (MHz)
-1	150	619	619	47.8
	30	698	698	32.3
	10	698	698	22.2
1	150	732	-	51.4
	30	806	-	33.9
	10	768	-	22.5
2	150	634	634	48.4
	30	698	698	33.0
	10	681	681	22.5
10	150	348	38.3	46.8
	30	357	39.2	36.7
	10	205	22.6	31.3

$R_{SD} = 15\text{k}\Omega$, $I_S = 7.5\text{mA}$, $V_S = \pm 5\text{V}$, Peaking $\leq 1\text{dB}$

A_V	$R_L (\Omega)$	$R_F (\Omega)$	$R_G (\Omega)$	-3dB BW (MHz)
-1	150	536	536	28.2
	30	549	549	20.0
	10	464	464	15.0
1	150	619	-	28.6
	30	634	-	19.8
	10	511	-	14.9
2	150	536	536	28.3
	30	549	549	19.9
	10	412	412	15.7
10	150	150	16.5	31.5
	30	118	13.0	27.1
	10	100	11.0	19.4

$R_{SD} = 82.5\text{k}\Omega$, $I_S = 9\text{mA}$, $V_S = \pm 15\text{V}$, Peaking $\leq 1\text{dB}$

A_V	$R_L (\Omega)$	$R_F (\Omega)$	$R_G (\Omega)$	-3dB BW (MHz)
-1	150	590	590	34.8
	30	649	649	22.5
	10	576	576	16.3
1	150	715	-	35.5
	30	768	-	22.5
	10	649	-	16.1
2	150	590	590	35.3
	30	665	665	22.5
	10	549	549	16.8
10	150	182	20.0	37.2
	30	182	20.0	28.9
	10	100	11.0	22.5

TYPICAL PERFORMANCE CHARACTERISTICS

Bandwidth vs Supply Voltage

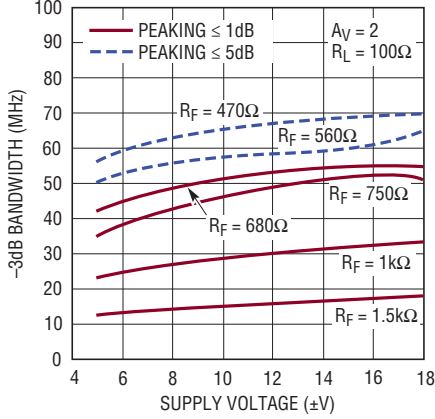

1210X G01

Bandwidth vs Supply Voltage

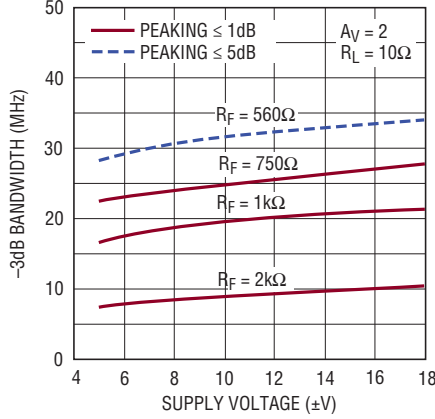

1210X G02

Bandwidth and Feedback Resistance vs Capacitive Load for Peaking $\leq 1\text{dB}$

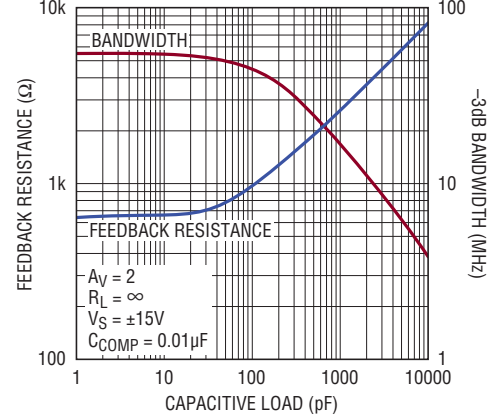

1210X G03

Bandwidth vs Supply Voltage

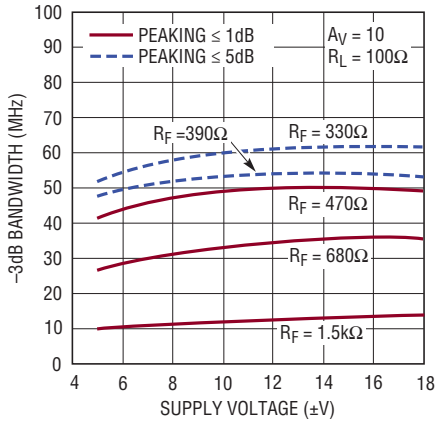

1210X G04

Bandwidth vs Supply Voltage

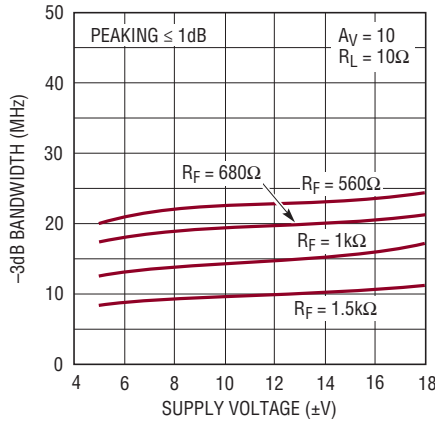

1210X G05

Bandwidth and Feedback Resistance vs Capacitive Load for Peaking $\leq 5\text{dB}$

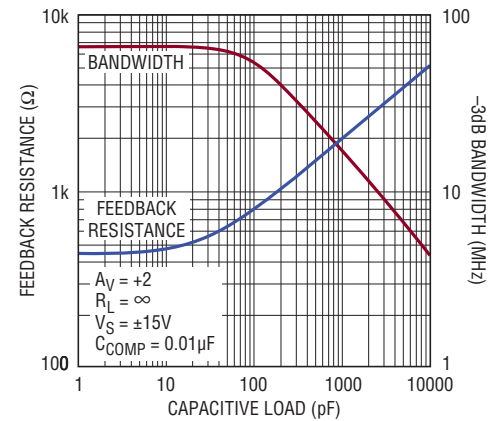

1210X G06

Differential Phase vs Supply Voltage

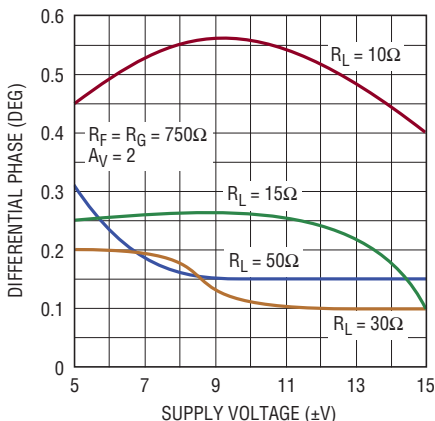

1210X G07

Differential Gain vs Supply Voltage

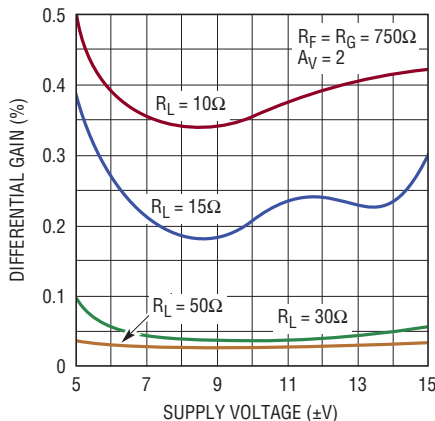

1210X G08

Spot Noise Voltage and Current vs Frequency

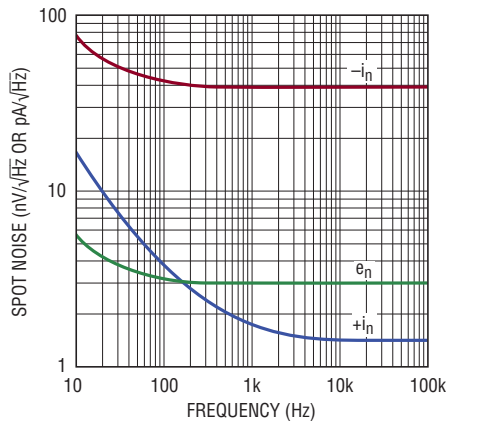

1210X G09

TYPICAL PERFORMANCE CHARACTERISTICS

Supply Current vs Supply Voltage

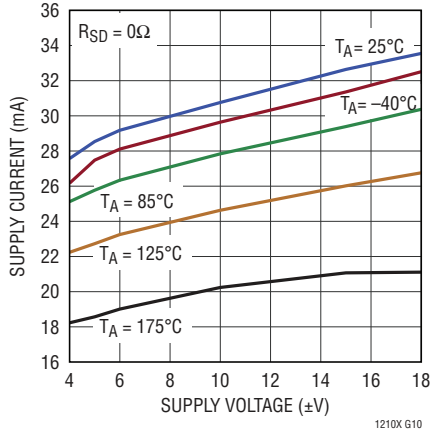

Supply Current vs Ambient Temperature, $V_S = \pm 5V$

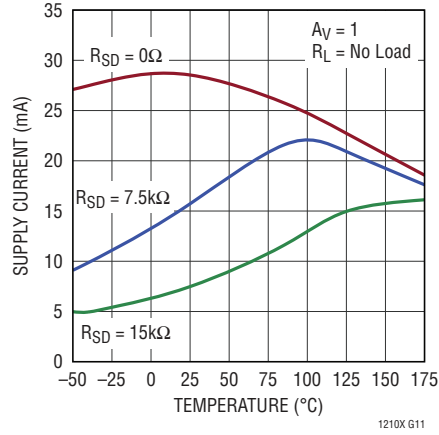

Supply Current vs Ambient Temperature, $V_S = \pm 15V$

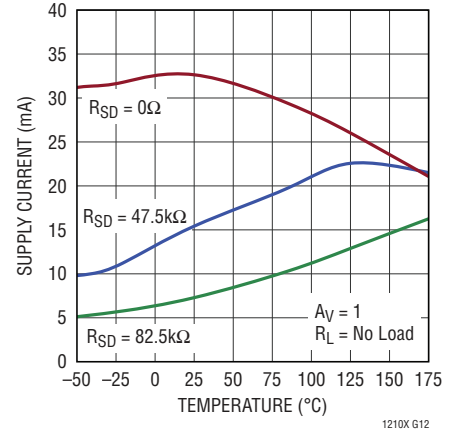

Supply Current vs Shutdown Pin Current

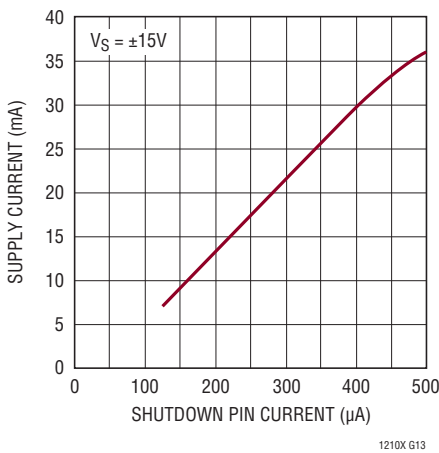

Input Common Mode Limit High vs Junction Temperature

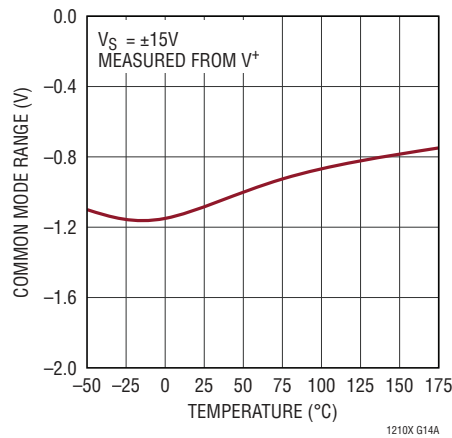

Input Common Mode Limit Low vs Junction Temperature

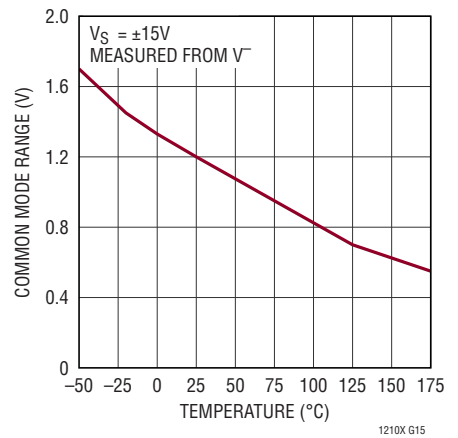

Output Short-Circuit Current vs Junction Temperature

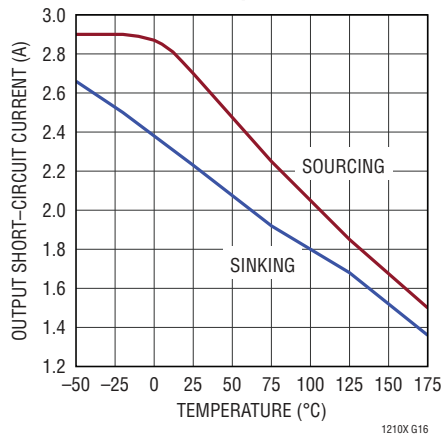

Output Saturation Voltage vs Junction Temperature (Output Low)

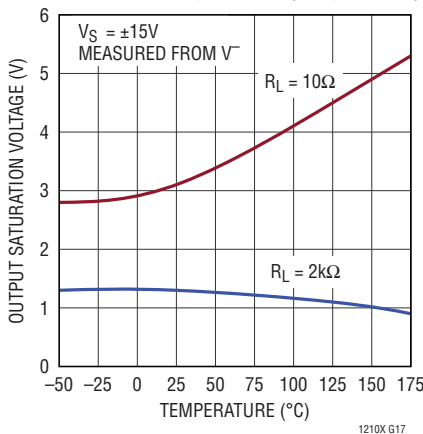

Output Saturation Voltage vs Junction Temperature (Output High)

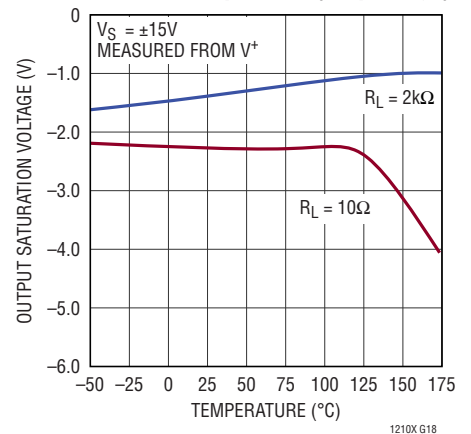

TYPICAL PERFORMANCE CHARACTERISTICS

Power Supply Rejection Ratio vs Frequency

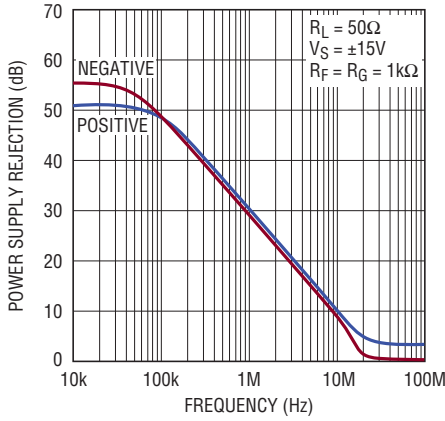

1210X G19

Supply Current vs Large-Signal Output Frequency (No Load)

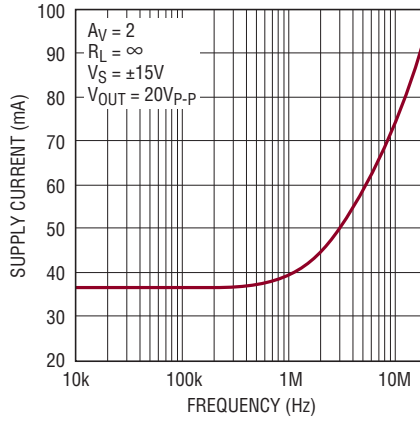

1210X G20

Output Impedance vs Frequency

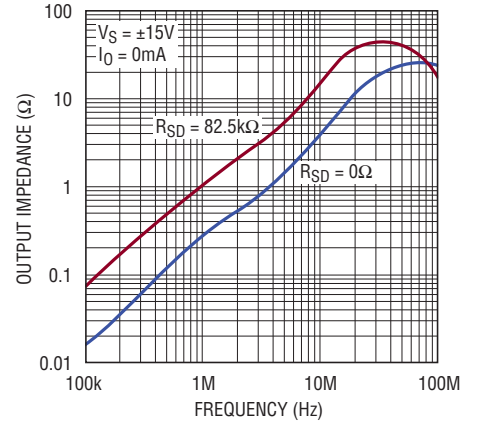

1210X G21

Output Impedance in Shutdown vs Frequency

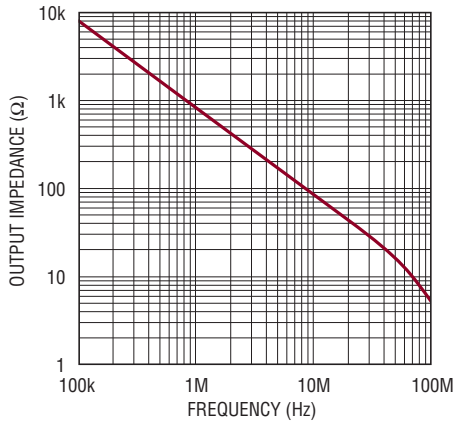

1210X G22

Large-Signal Voltage Gain vs Frequency

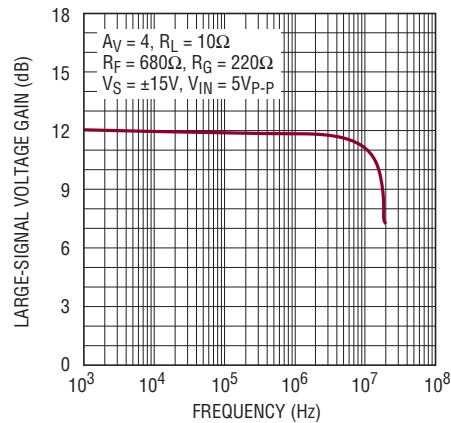

1210X G23

3rd Order Intercept vs Frequency

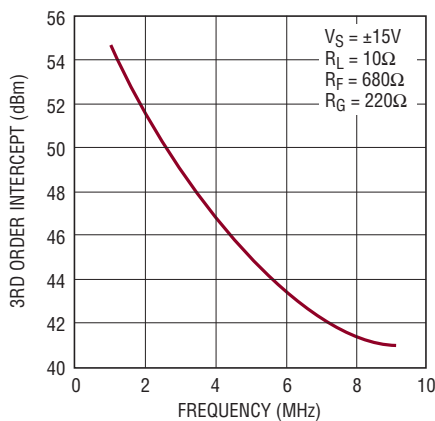

1210X G22

Test Circuit for 3rd Order Intercept

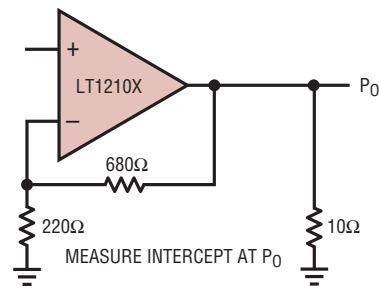

1210X T001

LT1210X

PIN FUNCTIONS

V⁺ (Pins 1, 8, 9, 16, 17): Positive Supply Voltage. V⁺ and V⁻ must be chosen so that $10V \leq (V^+ - V^-) < 36V$.

NC (Pins 2, 4, 5, 7, 10, 15): No Connection. These pins are floating, with no internal connection.

OUT (Pin 3): Amplifier Output. The output can source/sink a minimum of 1A over temperature.

-IN (Pin 6): Inverting Input of Amplifier. Valid input range is $\pm 12V$ on $\pm 15V$ supplies.

+IN (Pin 11): Non-Inverting Input of Amplifier. Valid input range is $\pm 12V$ on $\pm 15V$ supplies.

SHUTDOWN (Pin 12): If the shutdown feature is not used, the SHUTDOWN pin must be connected to Ground or V⁻. The SHUTDOWN pin can be used to either turn

off the biasing for the amplifier, reducing the quiescent current to less than 200 μ A, or to control the quiescent current in normal operation. For more information, refer to the Shutdown/Current Set section in the Applications Information.

COMP (Pin 13): Adding a 0.01 μ F capacitor between the output and the COMP pin greatly reduces peaking when driving capacitive loads. To disconnect the optional compensation, leave the COMP pin open. For more information, refer to the Capacitive Loads section in the Applications Information.

V⁻ (Pin 14): Negative Supply Voltage. V⁺ and V⁻ must be chosen so that $10V \leq (V^+ - V^-) < 36V$.

APPLICATIONS INFORMATION

The LT1210X is a current feedback amplifier with high output current drive capability. The device is stable with large capacitive loads and can easily supply the high currents required by capacitive loads. The amplifier will drive low impedance loads such as cables with excellent linearity at high frequencies.

Feedback Resistor Selection

The optimum value for the feedback resistors is a function of the operating conditions of the device, the load impedance and the desired flatness of response. The Typical AC Performance tables give the values which result in less than 1dB of peaking for various resistive loads and operating conditions. If this level of flatness is not required, a higher bandwidth can be obtained by use of a lower feedback resistor. The characteristic curves of Bandwidth vs Supply Voltage indicate feedback resistors for peaking up to 5dB. These curves use a solid line when the response has less than 1dB of peaking and a dashed line when the response has 1dB to 5dB of peaking. The curves stop where the response has more than 5dB of peaking.

For resistive loads, the COMP pin should be left open (see Capacitive Loads section).

Capacitive Loads

The LT1210X includes an optional compensation network for driving capacitive loads. This network eliminates most of the output stage peaking associated with capacitive loads, allowing the frequency response to be flattened. Figure 1 shows the effect of the network on a 200pF load. Without the optional compensation, there is a 6dB peak at 40MHz caused by the effect of the capacitance on the output stage. Adding a 0.01 μ F bypass capacitor between the output and the COMP pins connects the compensation and greatly reduces the peaking. A lower value feedback resistor can now be used, resulting in a response which is flat to $\pm 1dB$ to 40MHz. The network has the greatest effect for C_L in the range of 0pF to 1000pF. The graphs of Bandwidth and Feedback Resistance vs Capacitive Load can be used to select the appropriate value of feedback resistor. The values shown are for 1dB and 5dB peaking at a gain of 2 with no resistive load. This is a worst-case condition, as the amplifier is more stable at higher gains and with some resistive load in parallel with the capacitance. Also shown is the -3dB bandwidth with the suggested feedback resistor vs the load capacitance.

APPLICATIONS INFORMATION

Although the optional compensation works well with capacitive loads, it simply reduces the bandwidth when it is connected with resistive loads. For instance, with a 10Ω load, the bandwidth drops from 35MHz to 26MHz when the compensation is connected. Hence, the compensation was made optional. To disconnect the optional compensation, leave the COMP pin open.

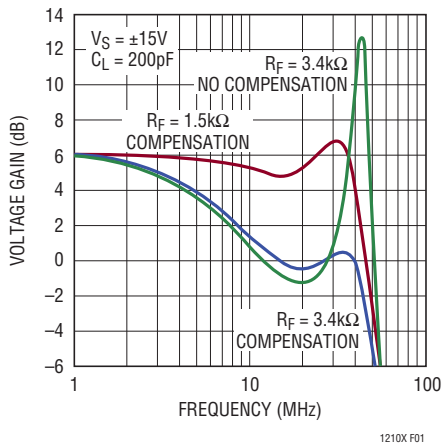

Figure 1

Shutdown/Current Set

If the shutdown feature is not used, the SHUTDOWN pin must be connected to ground or V^- .

The Shutdown pin can be used to either turn off the biasing for the amplifier, reducing the quiescent current to less than $200\mu\text{A}$, or to control the quiescent current in normal operation.

The total bias current in the LT1210X is controlled by the current flowing out of the Shutdown pin. When the Shutdown pin is open or driven to the positive supply, the part is shut down. In the shutdown mode, the output looks like a 70pF capacitor and the supply current is typically less than $100\mu\text{A}$. The Shutdown pin is referenced to the positive supply through an internal bias circuit (see the Simplified Schematic). An easy way to force shutdown is to use open-drain (collector) logic. The circuit shown in Figure 2 uses a 74C906 buffer to interface between 5V logic and the LT1210X. The switching time between the active and shutdown states is about $1\mu\text{s}$. A $24\text{k}\Omega$ pull-up resistor speeds up the turn-off time and ensures that the LT1210X is completely turned off. Because the pin is referenced to the positive supply, the logic used should

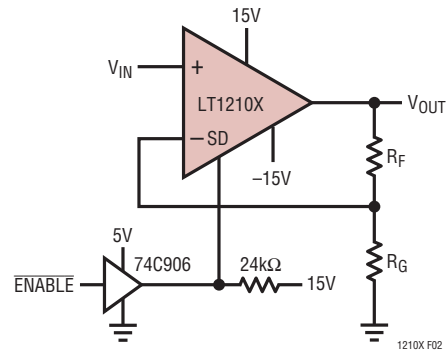

Figure 2. Shutdown Interface

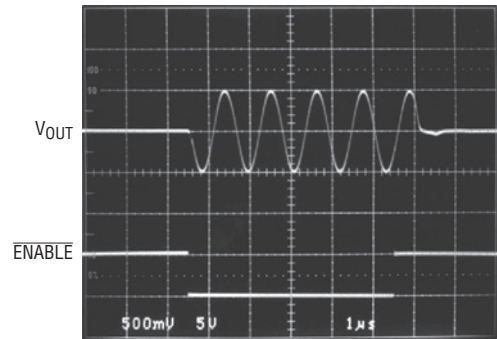

Figure 3. Shutdown Operation

have a breakdown voltage of greater than the positive supply voltage. No other circuitry is necessary as the internal circuit limits the Shutdown pin current to about $500\mu\text{A}$. Figure 3 shows the resulting waveforms.

For applications where the full bandwidth of the amplifier is not required, the quiescent current of the device may be reduced by connecting a resistor from the Shutdown pin to ground. The quiescent current will be approximately 65 times the current in the Shutdown pin. The voltage across the resistor in this condition is $V^+ - 3V_{BE}$. For example, a $82\text{k}\Omega$ resistor will set the quiescent supply current to 9mA with $V_S = \pm 15\text{V}$.

The photos in Figures 4a and 4b show the effect of reducing the quiescent supply current on the large-signal response. The quiescent current can be reduced to 9mA in the inverting configuration without much change in response. In noninverting mode, however, the slew rate is reduced as the quiescent current is reduced.

APPLICATIONS INFORMATION

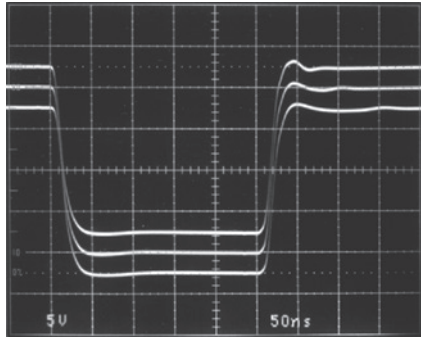

$R_F = 750\Omega$ $I_Q = 9mA, 18mA, 36mA$ 1210X F04a
 $R_L = 10\Omega$ $V_S = \pm 15V$

Figure 4a. Large-Signal Response vs I_Q , $A_V = -1$

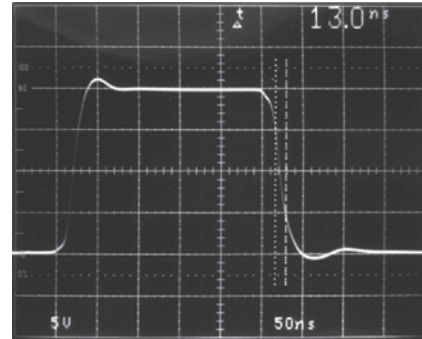

$R_F = 825\Omega$ $V_S = \pm 15V$ 1210X F05a
 $R_L = 10\Omega$

Figure 5a. Large-Signal Response, $A_V = 1$

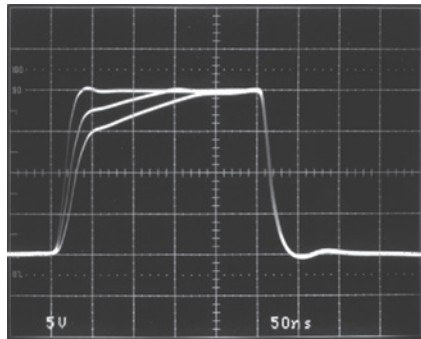

$R_F = 750\Omega$ $I_Q = 9mA, 18mA, 36mA$ 1210X F04b
 $R_L = 10\Omega$ $V_S = \pm 15V$

Figure 4b. Large-Signal Response vs I_Q , $A_V = 2$

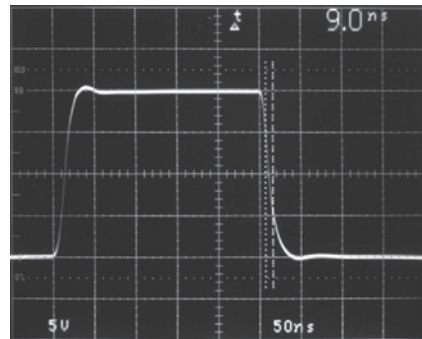

$R_F = R_G = 750\Omega$ $V_S = \pm 15V$ 1210X F05b
 $R_L = 10\Omega$

Figure 5b. Large-Signal Response, $A_V = -1$

Slew Rate

Unlike a traditional op amp, the slew rate of a current feedback amplifier is not independent of the amplifier gain configuration. There are slew rate limitations in both the input stage and the output stage. In the inverting mode, and for higher gains in the noninverting mode, the signal amplitude on the input pins is small and the overall slew rate is that of the output stage. The input stage slew rate is related to the quiescent current and will be reduced as the supply current is reduced. The output slew rate is set by the value of the feedback resistors and the internal capacitance. Larger feedback resistors will reduce the slew rate as will lower supply voltages, similar to the way the bandwidth is reduced. The photos in Figures 5a, 5b and 5c show the large-signal response of the LT1210X for various gain configurations. The slew rate varies from 770V/ μs for a gain of 1, to 1100V/ μs for a gain of -1.

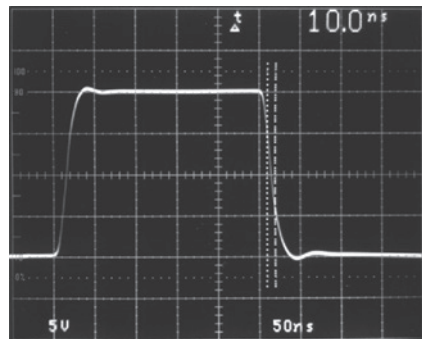

$R_F = R_G = 750\Omega$ $V_S = \pm 15V$ 1210X F05c
 $R_L = 10\Omega$

Figure 5c. Large-Signal Response, $A_V = 2$

APPLICATIONS INFORMATION

When the LT1210X is used to drive capacitive loads, the available output current can limit the overall slew rate. In the fastest configuration, the LT1210X is capable of a slew rate of over 1V/ns. The current required to slew a capacitor at this rate is 1mA per picofarad of capacitance, so 10,000pF would require 10A! The photo (Figure 6) shows the large-signal behavior with $C_L = 10,000\text{pF}$. The slew rate is about 150V/ μs , determined by the current limit of 1.5A.

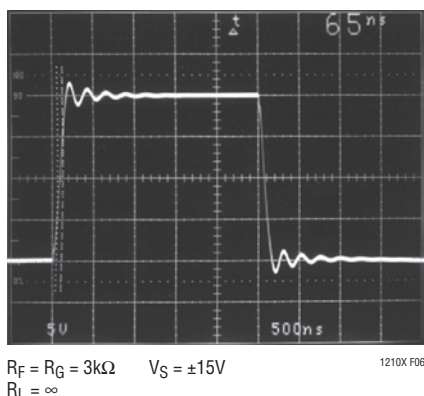

Figure 6. Large-Signal Response, $C_L = 10,000\text{pF}$

Differential Input Signal Swing

The differential input swing is limited to about $\pm 6\text{V}$ by an ESD protection device connected between the inputs. In normal operation, the differential voltage between the input pins is small, so this clamp has no effect; however, in the shutdown mode the differential swing can be the same as the input swing. The clamp voltage will then set the maximum allowable input voltage. To allow for some margin, it is recommended that the input signal be less than $\pm 5\text{V}$ when the device is shut down.

Capacitance on the Inverting Input

Current feedback amplifiers require resistive feedback from the output to the inverting input for stable operation. Take care to minimize the stray capacitance between the output and the inverting input. Capacitance on the inverting input to ground will cause peaking in the frequency response (and overshoot in the transient response), but it does not degrade the stability of the amplifier.

Power Supplies

The LT1210X will operate from single or split supplies from $\pm 5\text{V}$ (10V total) to $\pm 15\text{V}$ (30V total). It is not necessary to use equal value split supplies, however the offset voltage and inverting input bias current will change. The offset voltage changes about $500\mu\text{V}$ per volt of supply mismatch. The inverting bias current can change as much as $5\mu\text{A}$ per volt of supply mismatch, though typically the change is less than $0.5\mu\text{A}$ per volt.

Power Supply Bypassing

To obtain the maximum output and the minimum distortion from the LT1210X, the power supply rails should be well bypassed. For example, with the output stage pouring 1A current peaks into the load, a 1Ω power supply impedance will cause a droop of 1V, reducing the available output swing by that amount. Surface mount tantalum and ceramic capacitors make excellent low ESR bypass elements when placed close to the chip. For frequencies above 100kHz, use $1\mu\text{F}$ and 100nF ceramic capacitors. If significant power must be delivered below 100kHz, capacitive reactance becomes the limiting factor. Larger ceramic or tantalum capacitors, such as $4.7\mu\text{F}$, are recommended in place of the $1\mu\text{F}$ unit mentioned above.

Inadequate bypassing is evidenced by reduced output swing and “distorted” clipping effects when the output is driven to the rails. If this is observed, check the supply pins of the device for ripple directly related to the output waveform. Significant supply modulation indicates poor bypassing.

Thermal Considerations

For the TSSOP16-E package, heat sinking is accomplished by using the heat spreading capabilities of the PC board and its copper traces. Experiments have shown that the heat spreading copper layer does not need to be electrically connected to the tab of the device. The PCB material can be very effective at transmitting heat between the pad area attached to the tab of the device, and a ground or power plane layer either inside or on the opposite side of the board. Although the actual thermal resistance of the PCB material is high, the length/area ratio of the thermal

APPLICATIONS INFORMATION

resistance between the layer is small. Copper board stiffeners and plated through holes can also be used to spread the heat generated by the device.

Power Dissipation and Thermal Considerations

In order to avoid damaging the device, the absolute maximum junction temperature of the LT1210X should not be exceeded. At 35mA of quiescent supply current on $\pm 15V$ supplies, the LT1210X will consume approximately 1.05W.

In general, the die's junction temperature (T_J) can be estimated from the ambient temperature T_A , and the power dissipated in the device P_D :

$$T_J = T_A + P_D \cdot (\theta_{JC} + \theta_{CA})$$

θ_{JC} is the junction-to-case thermal resistance and is characterized to be approximately $10^\circ\text{C}/\text{W}$. θ_{CA} is the case-to-ambient thermal resistance and depends on circuit board layout, air flow and proximity to other sources of heat. The power dissipated in the IC is a function of supply voltage and the load being driven. Assuming split supplies, and a resistive load, the worst-case power dissipation $P_{D(\text{MAX})}$ occurs when the output is driving the load to half of either supply voltage. $P_{D(\text{MAX})}$, then is the sum of the quiescent power plus the power dissipated in the device due to the load with symmetric supply:

$$P_{D(\text{MAX})} (\text{Per Amplifier}) = (V_S \cdot I_S) + (V_S/4)^2/R_{\text{LOAD}}$$

(I_S is the quiescent supply current for the amplifier and V_S is the total supply voltage measured between the supplies)

For example, the theoretical peak power dissipation in the LT1210X application seen in Figure 7, driving 10Ω to ground with a $\pm 15V$ supply ($V_S = 30V$) would be:

$$(30V \cdot 35\text{mA}) + (30V/4)^2/10\Omega = 6.68\text{W}$$

Although this power dissipation is far too high for continuous operation, there is hope. The application in Figure 7 is for a $\pm 2V$ sinusoidal swing at the output, so we can reduce the power supplies from $\pm 15V$ to $\pm 5V$. Peak power dissipation would then be much more reasonable:

$$(10V \cdot 35\text{mA}) + (10V/4)^2/10\Omega = 0.98\text{W}$$

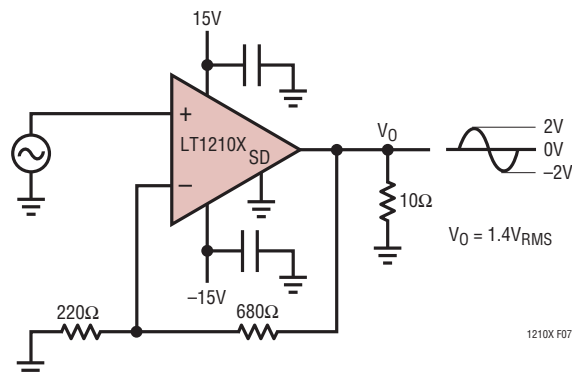

Figure 7

The exposed pad under the LT1210X is the primary conduit for conducting heat out of the package. Junction-to-ambient thermal resistance is strongly influenced by the number of PCB thermal vias below the exposed pad, the size of the thermal plane connected to these thermal vias, PCB thickness, air-flow, and proximity of other sources of heat. To minimize the amount of temperature rise within the package, the exposed pad must be soldered down to the PCB with multiple thermal vias tied to a thermal plane.

For a 4-layer PCB with the exposed pad of the LT1210X soldered to a land pattern containing eight 10mil diameter thermal vias which are connected to two 2 inch by 2 inch V^- thermal/power planes, the junction-to-ambient thermal resistance may be as low as $38^\circ\text{C}/\text{W}$ in still air. If the density of the PCB layout makes such large thermal planes impractical, Table 1 lists the thermal performance achieved of alternative layout examples. A minimally sized single layer thermal land under the device as shown in column D of Table 1 will result in a junction-to-ambient thermal resistance approaching $115^\circ\text{C}/\text{W}$. Since the LT1210X will dissipate 1.05W on $\pm 15V$ supplies, there will be approximately 121°C of junction-to-ambient temperature rise due to the device operation alone. This will then limit the specified ambient temperature range of the LT1210X can operate and/or will limit the load driven to prevent junction temperatures from exceeding $T_{J\text{MAX}}$ (200°C).

APPLICATIONS INFORMATION

For operation at 175°C ambient, extreme care must be taken to not exceed a junction temperature of 200°C. Large amounts of thermal plane area should be used. Furthermore, power supply voltages should be reduced as much as possible (down to a minimum of ±5V), the value of Rload should be increased as much as possible, and ISUPPLY of the LT1210X should be reduced as much as possible by using the CURRENT SET feature of the LT1210X.

For example, by using a thermal plane area much larger than Example A in Table 1, it is reasonable to achieve a θJA

of 50°C/W. By reducing supply voltages to ±5V, lowering ISUPPLY with RSD = 15kΩ and using a 25Ω load, maximum ambient temperature can be increased substantially. Assuming θJA can be reduced to 50°C/W and ISUPPLY can be reduced to 25mA:

$$t_{RISE} = (50^{\circ}\text{C/W}) \cdot [(10\text{V} \cdot 25\text{mA}) + ((10\text{V}/4)^2)/25\Omega]$$

$$= (50^{\circ}\text{C/W}) \cdot [0.25\text{W} + 0.25\text{W}] = 25^{\circ}\text{C}$$

This combination of techniques allows the LT1210X to operate continuously at an ambient temperature of 175°C with a maximum junction temperature of 200°C.

Table 1. Thermal Resistance vs PCB Thermal Plane Area

EXAMPLE A TOP LAYER A	EXAMPLE B TOP LAYER B	EXAMPLE C TOP LAYER C	EXAMPLE D TOP LAYER D
BOTTOM LAYER A	BOTTOM LAYER B	BOTTOM LAYER C	BOTTOM LAYER D
$\theta_{JA} = 90^{\circ}\text{C/W}$ $\theta_{JC} = 10^{\circ}\text{C/W}$ $\theta_{CA} = 80^{\circ}\text{C/W}$	$\theta_{JA} = 100^{\circ}\text{C/W}$ $\theta_{JC} = 10^{\circ}\text{C/W}$ $\theta_{CA} = 90^{\circ}\text{C/W}$	$\theta_{JA} = 108^{\circ}\text{C/W}$ $\theta_{JC} = 10^{\circ}\text{C/W}$ $\theta_{CA} = 98^{\circ}\text{C/W}$	$\theta_{JA} = 115^{\circ}\text{C/W}$ $\theta_{JC} = 10^{\circ}\text{C/W}$ $\theta_{CA} = 105^{\circ}\text{C/W}$

1210X TABLE 1

TYPICAL APPLICATIONS

CMOS Logic to Shutdown Interface

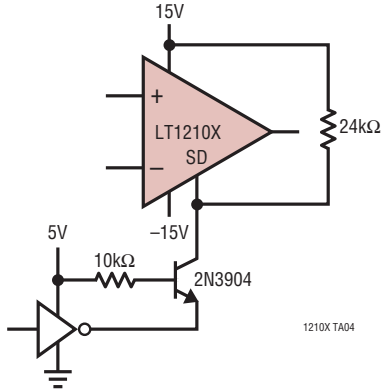

Distribution Amplifier

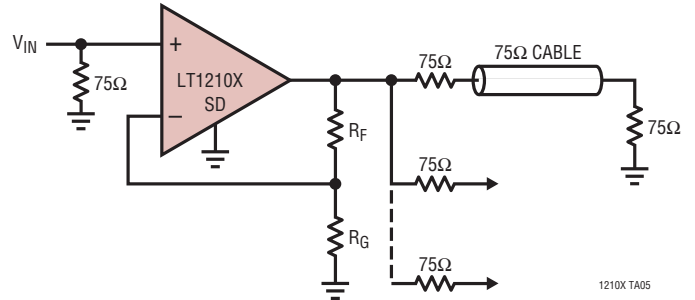

Buffer $A_V = 1$

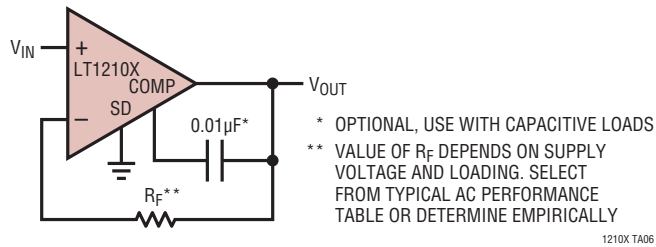

SIMPLIFIED SCHEMATIC

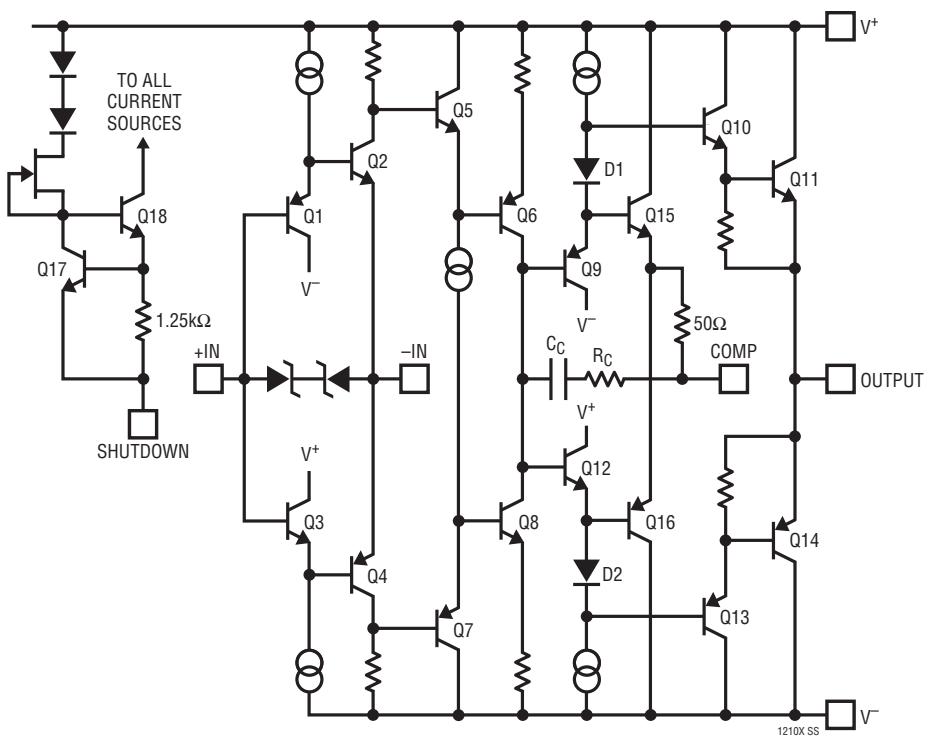

PACKAGE DESCRIPTION

Please refer to <http://www.linear.com/product/LT1210X#packaging> for the most recent package drawings.

FE Package
16-Lead Plastic TSSOP (4.4mm)
 (Reference LTC DWG # 05-08-1663 Rev L)
Exposed Pad Variation BB

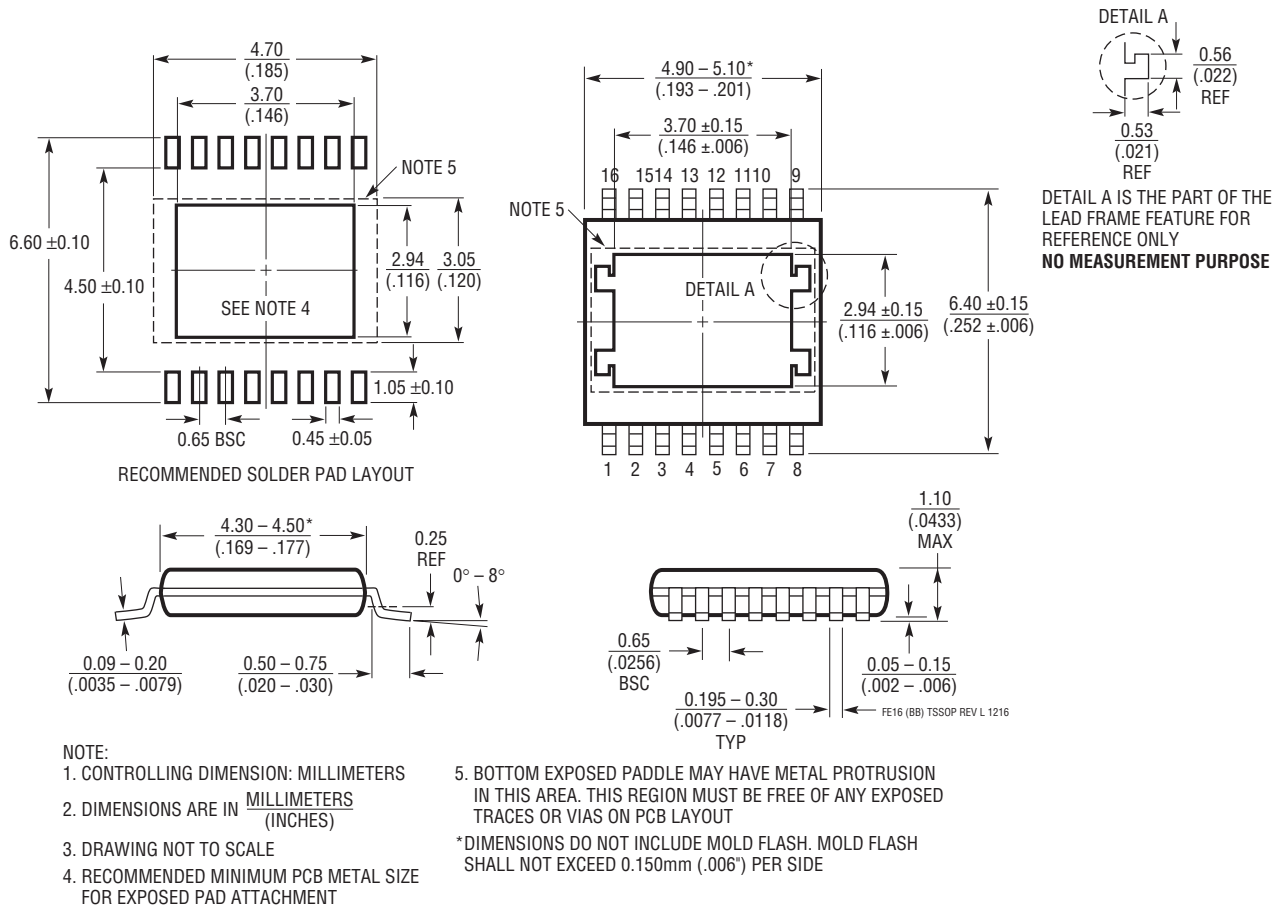

- NOTE:**
1. CONTROLLING DIMENSION: MILLIMETERS
 2. DIMENSIONS ARE IN $\frac{\text{MILLIMETERS}}{\text{INCHES}}$
 3. DRAWING NOT TO SCALE
 4. RECOMMENDED MINIMUM PCB METAL SIZE FOR EXPOSED PAD ATTACHMENT

5. BOTTOM EXPOSED PADDLE MAY HAVE METAL PROTRUSION IN THIS AREA. THIS REGION MUST BE FREE OF ANY EXPOSED TRACES OR VIAS ON PCB LAYOUT
- *DIMENSIONS DO NOT INCLUDE MOLD FLASH. MOLD FLASH SHALL NOT EXCEED 0.150mm (.006") PER SIDE

REVISION HISTORY

REV	DATE	DESCRIPTION	PAGE NUMBER
A	02/18	Created new temp grade version of LT1210 Series	1 to 18

TYPICAL APPLICATION

Wideband 9W Bridge Amplifier

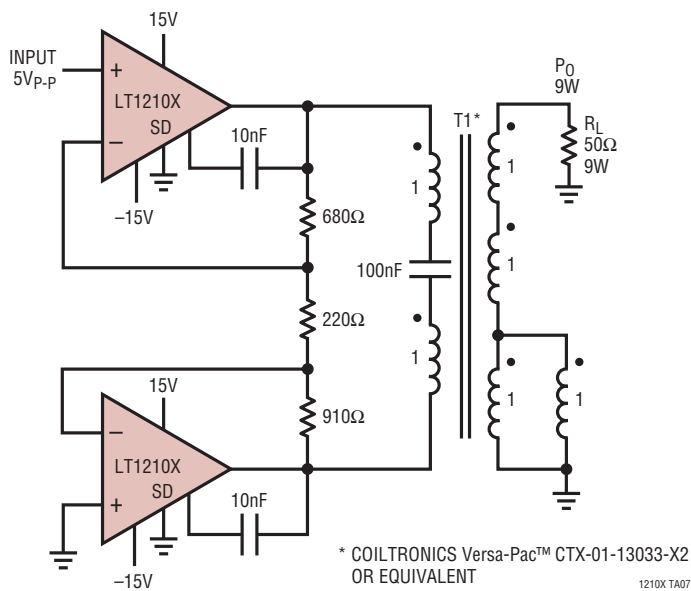

Frequency Response

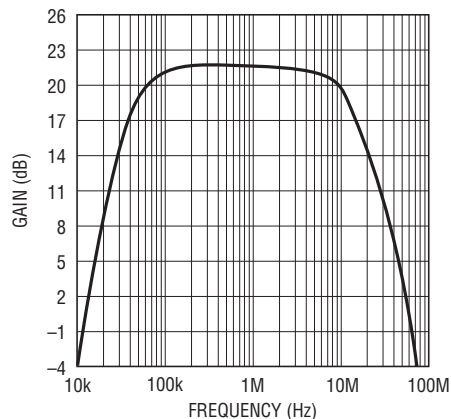

RELATED PARTS

PART NUMBER	DESCRIPTION	COMMENTS
LT1010	Fast ±150mA Power Buffer	20MHz Bandwidth, 75V/μs Slew Rate
LT1166	Power Output Stage Automatic Bias System	Sets Class AB Bias Currents for High Voltage/High Power Output Stages
LT1206	Single 250mA, 60MHz Current Feedback Amplifier	Shutdown Function, Stable with $C_L = 10,000\text{pF}$, 900V/μs Slew Rate
LT1207	Dual 250mA, 60MHz Current Feedback Amplifier	Dual Version of LT1206
LT1227	Single 140MHz Current Feedback Amplifier	Shutdown Function, 1100V/μs Slew Rate
LT1360	Single 50MHz, 800V/μs Op Amp	Voltage Feedback, Stable with $C_L = 10,000\text{pF}$
LT1363	Single 70MHz, 1000V/μs Op Amp	Voltage Feedback, Stable with $C_L = 10,000\text{pF}$
LTC6090/ LTC6090-5	140V Operational Amplifier	50pA I_B , 1.6mV V_{OS} , 9.5V to 140V V_S , 4.5μA I_S RR Output
LTC6091	140V Operational Amplifier	50pA I_B , 1.6mV V_{OS} , 9.5V to 140V V_S , 4.5μA I_S RR Output
LT6203X	High Temperature 175°C Dual 100MHz Op Amp	100MHz, RRIO, 1.9nV/√Hz, 2.5μA

Looking for pricing, stock, or lifecycle information?

Click below to explore more details on WIN SOURCE:

 [View LT1210XFE#TRPBF on WIN SOURCE](#)

 [Analog Devices Inc. Information](#)

Optimize Your Supply Chain with WIN SOURCE Solutions

-  Global Sourcing Solution
-  Obsolete Management
-  Cost Control Management
-  Shortage Management
-  Alternative Solution
-  Excess Inventory Management