



**THE DATASHEET OF  
LM2854-1000EVAL**



## AN-1880 LM2854 1MHz Buck Regulator Demo Board

### 1 Introduction

The LM2854 PowerWise™ SIMPLE SWITCHER® buck regulator demonstration board is a 1 MHz step-down voltage regulator capable of driving 0A up to 4A load current with excellent power conversion efficiency. A typical schematic of an LM2854 application is given in [Figure 1](#). The LM2854 pin-out and pin description are given in [Section 5](#).

The LM2854 demonstration board is designed to accept an input voltage rail between 2.95V and 5.5V and deliver a fixed and highly accurate output voltage of 1.2V. The output voltage level can be changed by modification of one feedback resistor value. Externally established soft-start with a small value capacitance facilitates a controlled, well-defined and monotonic start-up output voltage characteristic. In addition, the LM2854 is capable of starting monotonically and glitch free into a pre-biased load.

With some of the required voltage loop compensation components integrated in the regulator, the number of external passive components and PC board area typically necessary in a voltage mode buck converter application are reduced. An LM2854 based regulator design with type III loop compensation can be implemented with as few as eight external components. Only two small size external compensation components are required, similar to that commonly involved with current mode control compensation. Unlike a compensation solution where all the compensation components are integrated, the LM2854 has the flexibility to deal with ceramic and/or electrolytic based load capacitance spanning a wide range of capacitor values.

Lossless cycle-by-cycle peak current limit is used to protect the load from an overcurrent or short-circuit fault, and an enable comparator permits system sequencing or increase of the input UVLO above the nominal 2.7V level. The device is available in a power enhanced HTSSOP-16 package featuring an exposed die attach pad that improves the thermal performance of the regulator.

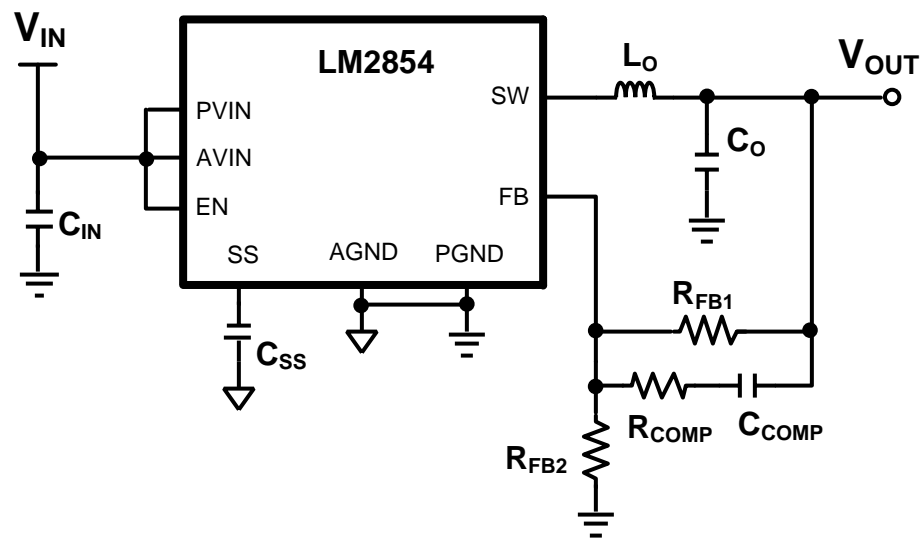

**Figure 1. Typical System Application Using LM2854 Synchronous Buck Regulator**

PowerWise is a trademark of Texas Instruments.  
SIMPLE SWITCHER is a registered trademark of Texas Instruments.  
All other trademarks are the property of their respective owners.

## 2 LM2854 Demo Board Details

This application solution relates to the bill of materials shown in [Section 6](#) and references the schematic diagram in [Figure 2](#). The board contains the LM2854MHX-1000 buck regulator IC with nominal switching frequency,  $f_{SW}$ , of 1MHz.

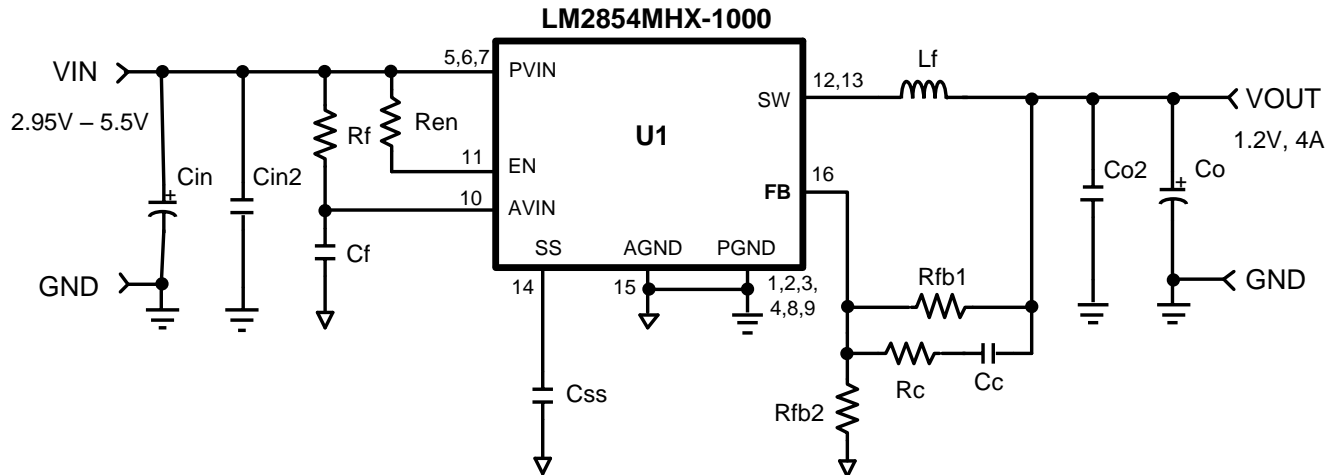

Figure 2. LM2854 Demo Board Schematic Diagram

## 3 Quick Step Procedure

**Step 1:** Set the power supply current limit to 3A. Turn off the power supply. Connect the power supply to the VIN and GND terminals.

**Step 2:** Connect the load with a 4A capability to the VOUT and GND terminals.

**Step 3:** The EN terminal can be left open for normal operation as there is an on-board pull-up resistor.

**Step 4:** Set  $V_{IN}$  to 3.0V with no load applied.  $V_{OUT}$  should be in regulation with a nominal 1.2V output.

**Step 5:** Slowly increase the load while monitoring the output voltage.  $V_{OUT}$  should remain in regulation with a nominal 1.2V output as the load is increased up to 4A.

**Step 6:** Slowly sweep the input voltage from 2.95V to 5.5V.  $V_{OUT}$  should remain in regulation with a nominal 1.2V output.

**Step 7:** Temporarily short the EN terminal to GND to check the shutdown function.

**Step 8:** Increase the load beyond the normal range to check current limit. The output current should limit at approximately 5.6A. Short the VOUT and GND terminals to verify short circuit protection.

## 4 Component Selection

### 4.1 Filter Inductor

The selection of the output filter components,  $L_f$  and  $C_o$ , are intrinsically linked as both of these parameters affect the stability of the system and various characteristics of the output voltage.

First, a 0.82  $\mu\text{H}$  inductor is chosen to allow stable operation (per datasheet recommendations) over the entire input voltage range from 2.95V to 5.5V. The inductance also directly affects the amplitude of the inductor current ripple which flows in the output capacitor. The filter inductance is given by:

$$L_f = \frac{V_{\text{OUT}}(1-D)}{\Delta i_L f_{\text{SW}}} = \frac{V_{\text{OUT}} \left(1 - \frac{V_{\text{OUT}}}{V_{\text{IN}}}\right)}{\Delta i_L f_{\text{SW}}} \quad (1)$$

where the variable  $D$  refers to the duty cycle and can be approximated by:

$$D = \frac{V_{\text{OUT}}}{V_{\text{IN}}} \quad (2)$$

From this, it follows that the inductor ripple current,  $\Delta i_L$ , reaches a maximum when duty cycle is minimum or input voltage is maximum, i.e.  $V_{\text{IN}} = 5.5\text{V}$ . Under these conditions, the inductor peak to peak ripple current is given by:

$$\Delta i_L = \frac{1.2\text{V} \left(1 - \frac{1.2\text{V}}{5.5\text{V}}\right)}{0.82 \mu\text{H} \times 1 \text{ MHz}} = 1.14\text{A} \quad (3)$$

or approximately 29% of full load current. It follows that the peak inductor current at full load is:

$$I_{\text{Lpk}} = I_{\text{OUT}} + \frac{\Delta i_L}{2} = 4\text{A} + \frac{1.14\text{A}}{2} = 4.57\text{A} \quad (4)$$

and this level is adequately below the peak inductor current associated with current limit, specified in the datasheet as 6.7A maximum. This implies that an inductor must be selected with a saturation current higher than 6.7A to ensure that the inductor will never saturate during normal or fault operating conditions.

This evaluation board uses the Vishay IHLP2525 series 0.82  $\mu\text{H}$  inductor to provide the necessary current handling capability with low DC resistance in a relatively small footprint and profile.

### 4.2 Output Capacitor

The output capacitance and its equivalent series resistance (ESR) affect both the ripple voltage at the output and the overall stability of the loop. The output capacitor provides a low impedance path for the inductor ripple current and presents a source of charge for transient loading conditions.

In this example, one 47  $\mu\text{F}$  1206 multi-layer ceramic capacitor (MLCC) was selected. Ceramic capacitors provide very low ESR but can exhibit a significant reduction in capacitance with applied DC bias. Using manufacturer's data, the ESR at 1 MHz is 3  $\text{m}\Omega$  and there is approximately 40% reduction in capacitance at 1.2V. This is verified by measuring the output ripple voltage and frequency response of the circuit. The fundamental component of the output ripple voltage amplitude is calculated as:

$$\Delta V_{\text{OUT}} = \Delta i_L \sqrt{R_{\text{ESR}}^2 + \left(\frac{1}{8f_{\text{SW}}C_o}\right)^2} \quad (5)$$

and with typical values from this example:

$$\Delta V_{\text{OUT}} = 1.14\text{A} \sqrt{(3 \text{ m}\Omega)^2 + \left(\frac{1}{8 \times 1 \text{ MHz} \times 30 \mu\text{F}}\right)^2} = 5.8 \text{ mV} \quad (6)$$

Because the load could transition quickly from no load to full load, it is sometimes common to add output bulk capacitance in the form of aluminum electrolytic (Al-E), tantalum (Ta), solid aluminum, organic polymer, and niobium (Nb) capacitors. This is largely unnecessary with the LM2854 as the loop crossover frequency can be made sufficiently large to accommodate high di/dt load transients.

### 4.3 Input Filter

The necessary RMS current rating of the input capacitor can be estimated by the following equation:

$$I_{Cin(RMS)} = I_{OUT}\sqrt{D(1-D)} \quad (7)$$

From this equation, it follows that the maximum RMS current will occur at full 4A load current with the system operating at 50% duty cycle.

However, with the specified output voltage, the worst case occurs at minimum input voltage of 2.95V. Hence, the relevant duty cycle is 0.41 and the maximum RMS current is given by:

$$I_{Cin(RMS)} = 4A\sqrt{0.41(1-0.41)} = 1.97A \quad (8)$$

Ceramic capacitors feature a very large RMS current rating in a small footprint making them ideal for this application. Choosing a 47  $\mu$ F 10V ceramic capacitor to provide the necessary input capacitance and assuming 50% capacitance voltage coefficient, the input AC ripple amplitude, neglecting ESR, is:

$$\Delta V_{IN} = \frac{I_{OUT}D(1-D)}{f_{SW}C_{in}} = \frac{4A \cdot 0.41(1-0.41)}{1 \text{ MHz} \cdot 100 \mu\text{F}} = 10 \text{ mV} \quad (9)$$

When operating near the minimum input voltage, an electrolytic input capacitor is helpful to damp the input for a typical bench test setup. Essentially, a resonant circuit is formed by the line impedance and input capacitance. The 6TPE100MPB by Sanyo has 100  $\mu$ F capacitance and an ESR of 25 m $\Omega$ . The associated ESR is stable relative to temperature, and capacitance change is relatively immune to bias voltage.

For improved performance, an 0603 1  $\mu$ F ceramic AVIN filter capacitor is placed adjacent to the AVIN pin and referenced to AGND. Together with a 1 $\Omega$  series resistor from PVIN (optional), this small capacitor helps to filter high frequency noise spikes on the supply rail and prevent these pulses from disturbing the analog control circuitry of the chip.

### 4.4 Soft-Start Capacitor

A 10 nF soft-start capacitor has been chosen to provide a soft-start time of roughly 4 ms. This will allow the LM2854 to start up gracefully without triggering over-current protection irrespective of operating conditions.

### 4.5 Feedback and Compensation Components

The voltage loop crossover frequency,  $f_{loop}$ , is usually selected between one tenth and one fifth of the switching frequency:

$$0.1 f_{SW} \leq f_{loop} \leq 0.2 f_{SW} \quad (10)$$

The complex double pole related to the LC output filter and zero due to the output capacitor ESR are as follows:

$$f_{LC} \cong \frac{1}{2\pi\sqrt{LfCo}} = \frac{1}{2\pi\sqrt{0.82 \mu\text{H} \cdot 30 \mu\text{F}}} = 32.1 \text{ kHz}$$

$$f_{ESR} \cong \frac{1}{2\pi R_{ESR}Co} = \frac{1}{2\pi \cdot 3 \text{ m}\Omega \cdot 30 \mu\text{F}} = 1.7 \text{ MHz} \quad (11)$$

A simple solution for the required external compensation capacitor,  $C_{COMP}$ , with type III voltage mode control can be expressed as follows, where the constant  $\alpha$  is nominally 0.075 for the 1MHz option.

$$C_c(\text{pF}) = \alpha \frac{Lf(\mu\text{H})Co(\mu\text{F})}{V_{IN}(\text{V})} f_{loop}(\text{kHz}) \quad (12)$$

Selecting a loop crossover frequency of 100 kHz yields:

$$C_c = 0.075 \frac{0.82 \cdot 30}{5.5} 100 = 33 \text{ pF} \quad (13)$$

The upper feedback resistor, Rfb1, is selected to provide adequate mid-band gain and to locate a zero at or below the LC pole frequency. The series resistor, Rc1, is selected to locate a pole at the ESR zero frequency. Thus:

$$R_{fb1} = \frac{1}{2\pi C_{f_{LC}}} = \frac{1}{2\pi \cdot 33 \text{ pF} \cdot 32.1 \text{ kHz}} = 150 \text{ k}\Omega$$

$$R_c = \frac{1}{2\pi C_{f_{ESR}}} = \frac{1}{2\pi \cdot 33 \text{ pF} \cdot 1.7 \text{ MHz}} = 2.8 \text{ k}\Omega \quad (14)$$

Rfb1 and Rc are chosen as 150 kΩ and 2 kΩ in the demo board. With Rfb1 defined based on the voltage loop requirements, Rfb2, the lower feedback resistor, is then selected for the desired output voltage by:

$$R_{fb2} = \frac{R_{fb1}}{\left(\frac{V_{OUT}}{0.8V} - 1\right)} = \frac{150 \text{ k}\Omega}{\left(\frac{1.2V}{0.8V} - 1\right)} = 301 \text{ k}\Omega \quad (15)$$

Note that Rfb2 has no impact on the control loop from an AC standpoint since the FB pin is the input to an op-amp type error amplifier and effectively at AC ground. Hence, the control loop can be designed irrespective of output voltage level. The only caveat here is the necessary derating of the output capacitance with applied voltage.

The compensation was optimized to work over the full input voltage range. Many applications have a fixed input voltage rail. It is possible to modify the compensation to obtain a faster transient response for a given input voltage operating point.

## 5 LM2854 Pin-Out

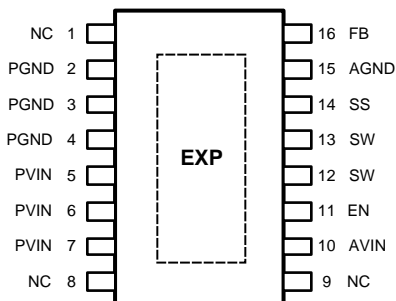

**Figure 3. LM2854 Pin-Out**

**Table 1. LM2854 Pin Descriptions**

Pin Number	Name	Description
1	NC	No connect. This pin should be tied to ground in the application.
2,3,4	PGND	Power ground.
5,6,7	PVIN	Power voltage input.
8,9	NC	No connect. This pin should be tied to ground in the application.
10	AVIN	Analog voltage input.
11	EN	Enable input.
12,13	SW	Switch node.
14	SS	Soft-start pin.
15	AGND	Analog ground.
16	FB	Voltage feedback pin.
EXP	Exposed Pad	Exposed pad should be connected to ground.

## 6 Bill of Materials

**Table 2. LM2854 Bill of Materials ( $V_{IN} = 2.95V$  to  $5.5V$ ,  $V_{OUT} = 1.2V$ ,  $I_{OUT (MAX)} = 4A$ )**

Ref. Des.	Function	Description	Case Size	Manufacturer	Manufacturer P/N
U1	Buck Regulator	Synchronous Buck Regulator	HTSSOP-16	Texas Instruments	LM2854
Cin	Input Filter	100 $\mu F$ , 6.3V	B2, 3.5 x 2.8 x 1.9mm	Sanyo	6TPE100MAPB
Cin2	Input Filter	Not Assembled	1210	-	-
Co	Output Filter	47 $\mu F$ , X5R, 6.3V	1206	TDK	C3216X5R0J476M
Co2	Output Filter	Not Assembled	1210	-	-
Lf	Output Filter	0.82 $\mu H$ , 14 m $\Omega$	6.9 x 6.5 x 1.8 mm	Vishay Dale	IHLP2525AHERR82M01
Rfb1	Upper FB Resistor	150 k $\Omega$	0603	Vishay Dale	CRCW06032493F-e3
Rfb2	Lower FB Resistor	301 k $\Omega$	0603	Vishay Dale	CRCW06034993F-e3
Rc	Compensation Resistor	2.0 k $\Omega$	0603	Vishay Dale	CRCW06031001F-e3
Rf	AVIN Filter Resistor	1.0 $\Omega$	0603	Vishay Dale	CRCW06031R0F-e3
Ren	Enable Resistor	100 k $\Omega$	0603	Vishay Dale	CRCW06031003F-e3
Cc	Compensation Capacitor	33 pF, $\pm 5\%$ , C0G, 50V	0603	TDK	C1608C0G1H330J
Css	Soft-start Capacitor	10 nF, $\pm 10\%$ , X7R, 50V	0603	TDK	C1608X7R1H103K
Cf	AVIN Filter Capacitor	1.0 $\mu F$ , $\pm 10\%$ , X7R, 16V	0603	TDK	C1608X7R1C105K

## 7 Performance Characteristics

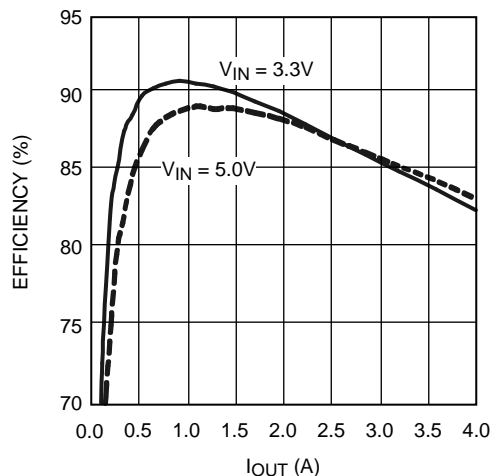
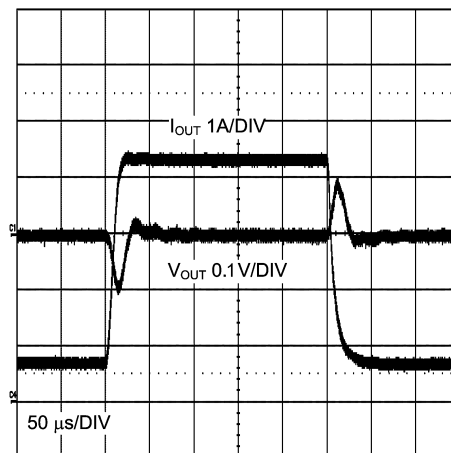
**Figure 4. LM2854 Demo Board Efficiency**  
 $V_{OUT} = 1.2V$ 

**Figure 5. LM2854 Transient Response**  
 $I_{OUT} = 0.4A - 4.0A - 0.4A$

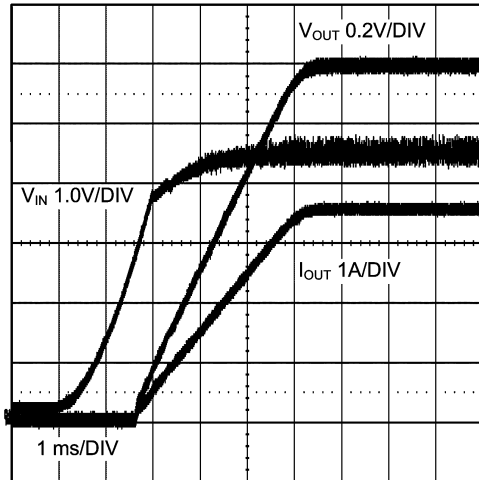

Figure 6. LM2854 Startup Characteristic

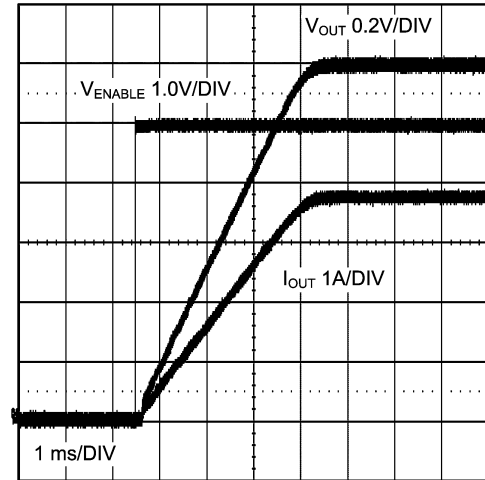

Figure 7. LM2854 Turn On via Enable

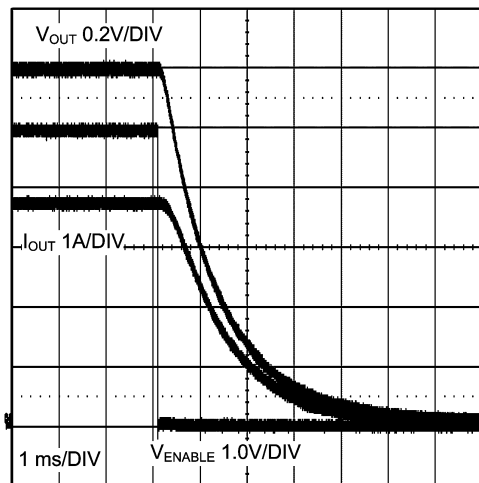

Figure 8. LM2854 Turn Off via Enable

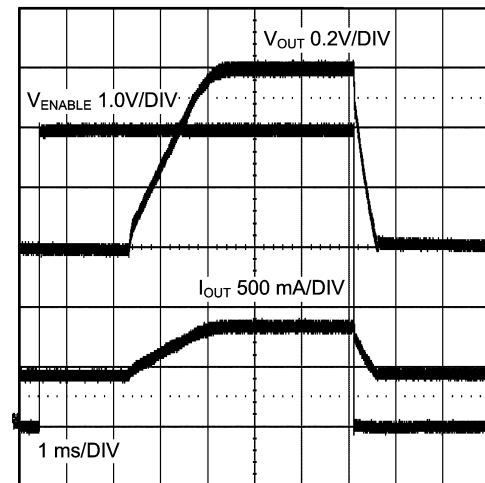

Figure 9. LM2854 Pre-Biased Turn On and Off via Enable

$$V_{OUT(PRE-BIAS)} = 0.6V$$

## 8 LM2854 PC Board Layout

The demo board is based on a small 1.15" × 0.64" × 0.062" (29 mm × 16 mm × 1.6 mm) FR4 laminate PCB with two layers of two ounce copper. The top and bottom side layouts can be seen in [Figure 10](#) and [Figure 11](#). When looking at the top layer, pin 1 of the LM2854 is on the upper left.

The PCB layout of the LM2854 evaluation board was designed to occupy as little board space as possible, while still following sound layout guidelines and techniques. The input capacitor,  $C_{in}$ , is placed as close as possible to the PVIN and PGND pins to minimize stray resistance and inductance between  $C_{in}$  and the LM2854. Likewise, the AVIN bypass capacitor is placed as close as possible to the AVIN and AGND pins. PGND and AGND are connected to each other and the ground plane at a single point, the exposed pad of the LM2854.

Also, in order to help conduct heat to the ground plane and away from the LM2854, a 3 × 3 via array is used to electrically and thermally connect the exposed pad to the ground plane (instead of a single via). Additional ground plane vias are located close to the three PGND pins and in the localized ground plane emanating away from the exposed pad.

Finally, the FB pin trace is intentionally kept as short as possible and routed away from the SW node to minimize any EMI pickup.

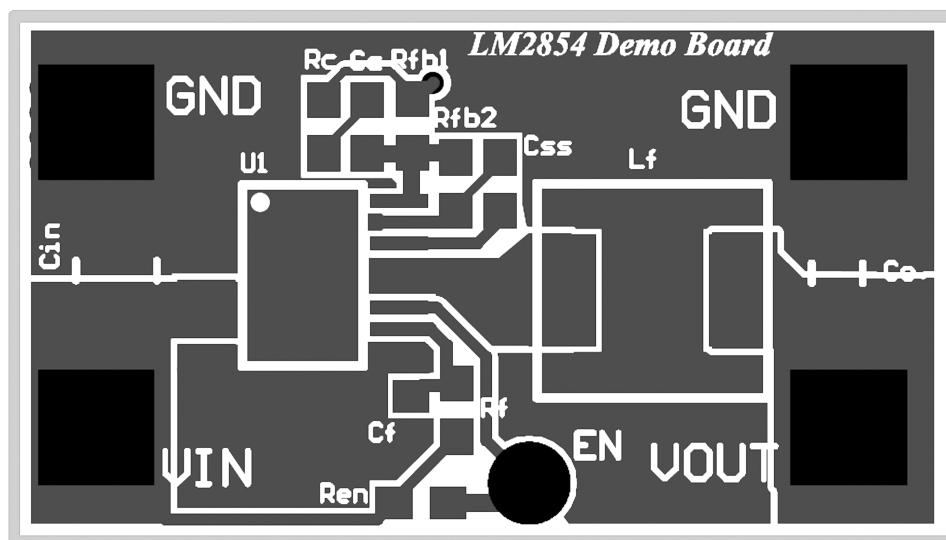

Figure 10. LM2854 Top Side PCB Layout

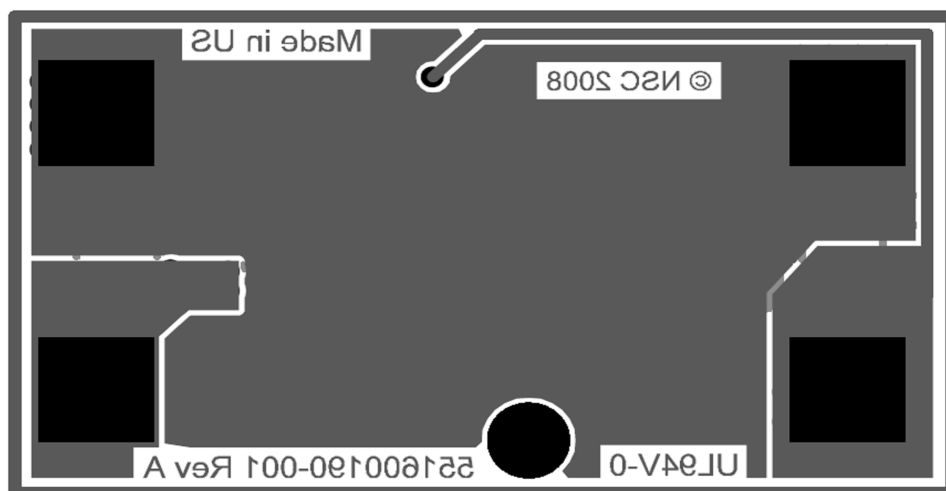

Figure 11. LM2854 Bottom Side PCB Layout, Viewed from Top

## IMPORTANT NOTICE

Texas Instruments Incorporated and its subsidiaries (TI) reserve the right to make corrections, enhancements, improvements and other changes to its semiconductor products and services per JESD46, latest issue, and to discontinue any product or service per JESD48, latest issue. Buyers should obtain the latest relevant information before placing orders and should verify that such information is current and complete. All semiconductor products (also referred to herein as "components") are sold subject to TI's terms and conditions of sale supplied at the time of order acknowledgment.

TI warrants performance of its components to the specifications applicable at the time of sale, in accordance with the warranty in TI's terms and conditions of sale of semiconductor products. Testing and other quality control techniques are used to the extent TI deems necessary to support this warranty. Except where mandated by applicable law, testing of all parameters of each component is not necessarily performed.

TI assumes no liability for applications assistance or the design of Buyers' products. Buyers are responsible for their products and applications using TI components. To minimize the risks associated with Buyers' products and applications, Buyers should provide adequate design and operating safeguards.

TI does not warrant or represent that any license, either express or implied, is granted under any patent right, copyright, mask work right, or other intellectual property right relating to any combination, machine, or process in which TI components or services are used. Information published by TI regarding third-party products or services does not constitute a license to use such products or services or a warranty or endorsement thereof. Use of such information may require a license from a third party under the patents or other intellectual property of the third party, or a license from TI under the patents or other intellectual property of TI.

Reproduction of significant portions of TI information in TI data books or data sheets is permissible only if reproduction is without alteration and is accompanied by all associated warranties, conditions, limitations, and notices. TI is not responsible or liable for such altered documentation. Information of third parties may be subject to additional restrictions.

Resale of TI components or services with statements different from or beyond the parameters stated by TI for that component or service voids all express and any implied warranties for the associated TI component or service and is an unfair and deceptive business practice. TI is not responsible or liable for any such statements.

Buyer acknowledges and agrees that it is solely responsible for compliance with all legal, regulatory and safety-related requirements concerning its products, and any use of TI components in its applications, notwithstanding any applications-related information or support that may be provided by TI. Buyer represents and agrees that it has all the necessary expertise to create and implement safeguards which anticipate dangerous consequences of failures, monitor failures and their consequences, lessen the likelihood of failures that might cause harm and take appropriate remedial actions. Buyer will fully indemnify TI and its representatives against any damages arising out of the use of any TI components in safety-critical applications.

In some cases, TI components may be promoted specifically to facilitate safety-related applications. With such components, TI's goal is to help enable customers to design and create their own end-product solutions that meet applicable functional safety standards and requirements. Nonetheless, such components are subject to these terms.

No TI components are authorized for use in FDA Class III (or similar life-critical medical equipment) unless authorized officers of the parties have executed a special agreement specifically governing such use.

Only those TI components which TI has specifically designated as military grade or "enhanced plastic" are designed and intended for use in military/aerospace applications or environments. Buyer acknowledges and agrees that any military or aerospace use of TI components which have **not** been so designated is solely at the Buyer's risk, and that Buyer is solely responsible for compliance with all legal and regulatory requirements in connection with such use.

TI has specifically designated certain components as meeting ISO/TS16949 requirements, mainly for automotive use. In any case of use of non-designated products, TI will not be responsible for any failure to meet ISO/TS16949.

### Products

Audio	<a href="http://www.ti.com/audio">www.ti.com/audio</a>
Amplifiers	<a href="http://amplifier.ti.com">amplifier.ti.com</a>
Data Converters	<a href="http://dataconverter.ti.com">dataconverter.ti.com</a>
DLP® Products	<a href="http://www.dlp.com">www.dlp.com</a>
DSP	<a href="http://dsp.ti.com">dsp.ti.com</a>
Clocks and Timers	<a href="http://www.ti.com/clocks">www.ti.com/clocks</a>
Interface	<a href="http://interface.ti.com">interface.ti.com</a>
Logic	<a href="http://logic.ti.com">logic.ti.com</a>
Power Mgmt	<a href="http://power.ti.com">power.ti.com</a>
Microcontrollers	<a href="http://microcontroller.ti.com">microcontroller.ti.com</a>
RFID	<a href="http://www.ti-rfid.com">www.ti-rfid.com</a>
OMAP Applications Processors	<a href="http://www.ti.com/omap">www.ti.com/omap</a>
Wireless Connectivity	<a href="http://www.ti.com/wirelessconnectivity">www.ti.com/wirelessconnectivity</a>

### Applications

Automotive and Transportation	<a href="http://www.ti.com/automotive">www.ti.com/automotive</a>
Communications and Telecom	<a href="http://www.ti.com/communications">www.ti.com/communications</a>
Computers and Peripherals	<a href="http://www.ti.com/computers">www.ti.com/computers</a>
Consumer Electronics	<a href="http://www.ti.com/consumer-apps">www.ti.com/consumer-apps</a>
Energy and Lighting	<a href="http://www.ti.com/energy">www.ti.com/energy</a>
Industrial	<a href="http://www.ti.com/industrial">www.ti.com/industrial</a>
Medical	<a href="http://www.ti.com/medical">www.ti.com/medical</a>
Security	<a href="http://www.ti.com/security">www.ti.com/security</a>
Space, Avionics and Defense	<a href="http://www.ti.com/space-avionics-defense">www.ti.com/space-avionics-defense</a>
Video and Imaging	<a href="http://www.ti.com/video">www.ti.com/video</a>

### TI E2E Community

[e2e.ti.com](http://e2e.ti.com)

## Looking for pricing, stock, or lifecycle information?

Click below to explore more details on WIN SOURCE:

 [View LM2854-1000EVAL](#) on WIN SOURCE

 [Texas Instruments](#) Information

## Optimize Your Supply Chain with WIN SOURCE Solutions

-  Global Sourcing Solution
-  Obsolete Management
-  Cost Control Management
-  Shortage Management
-  Alternative Solution
-  Excess Inventory Management