



THE DATASHEET OF LA.02





TAOGLAS®



Datasheet

2.4GHz Embedded Loop Chip Antenna

Part No:
LA.02

Description

1dBi 2400MHz to 2500MHz Wi-Fi/Bluetooth/Bluetooth LE/ ZigBee

Features:

8*2*2mm Ceramic Antenna

Surface Mount

Low Profile

Peak gain 1.9dBi

50 Ohm Impedance

Components can be mounted on opposite side of board to the antenna

RoHS & REACH Compliant

1.	Introduction	2
2.	Specification	4
3.	Antenna Characteristics	5
4.	Radiation Patterns	8
5.	Mechanical Drawing	12
6.	Antenna Integration Guide	13
7.	Solder Reflow Profile	19
8.	Packaging	20
<hr/>		
	Changelog	22

Taoglas makes no warranties based on the accuracy or completeness of the contents of this document and reserves the right to make changes to specifications and product descriptions at any time without notice. Taoglas reserves all rights to this document and the information contained herein. Reproduction, use or disclosure to third parties without express permission is strictly prohibited.



1. Introduction



The LA.02 is a 2.4GHz embedded loop chip antenna that has best in class efficiency, 70% on center frequency. It's a miniature SMD ceramic component, designed to be mounted directly on the edge of the main device PCB and is suitable especially for very small space requirements for Bluetooth LE, Wi-Fi, 802.11 applications. The LA.02 uses this main PCB ground plane to increase antenna efficiency, requiring minimum ground-clearance around the antenna. The opposite side of the board on which the antenna is mounted does not need ground-clearance, allowing more space for components or signal routing. This antenna is delivered on tape and reel.

Some frequency offset may happen as is normal with antennas embedded devices, so the antenna can be tuned for different PCB sizes and enclosures by simply changing the value of the matching circuit. Please contact your regional Taoglas sales office for support.

Many module manufacturers specify peak gain limits for any antennas that are to be connected to that module. Those peak gain limits are based on free-space conditions. In practice, the peak gain of an antenna tested in free-space can degrade by at least 1 or 2dBi when put inside a device. So ideally you should go for a slightly higher peak gain antenna than mentioned on the module specification to compensate for this effect, giving you better performance.

Upon testing of any of our antennas with your device and a selection of appropriate layout, integration technique, or cable, Taoglas can make sure any of our antennas' peak gain will be below the peak gain limits. Taoglas can then issue a specification and/or report for the selected antenna in your device that will clearly show it complying with the peak gain limits, so you can be assured you are meeting regulatory requirements for that module.

For example, a module manufacturer may state that the antenna must have less than 2dBi peak gain, but you don't need to select an embedded antenna that has a peak gain of less than 2dBi in free-space. This will give you a less optimized solution. It is better to go for a slightly higher free-space peak gain of 3dBi or more if available. Once that antenna gets integrated into your device, performance will degrade below this 2dBi peak gain due to the effects of GND plane, surrounding components, and device housing. If you want to be absolutely sure, contact Taoglas and we will test. Choosing a Taoglas antenna with a higher peak gain than what is specified by the module manufacturer and enlisting our help will ensure you are getting the best performance possible without exceeding the peak gain limits.

This antenna can be mounted with no performance degradation in either orientation as long as the antenna is soldered correctly via Surface mounting. Please see the integration instructions section for further detail regarding the optimum way to integrate this antenna into your device.

For further optimization to customer-specific device environments and for support to integrate and test this antennas performance in your device, contact your regional Taoglas Customer Services Team.

Applications:

- Telematics devices
- Bluetooth LE Wearables
- Bluetooth Headsets
- Hand-held devices when Bluetooth/Wi-Fi functions are needed, e.g., smart phone.
- IEEE802.11 b/g
- ZigBee
- Wireless PCMCIA cards or USB dongle

2. Specification

Electrical								
Band	Frequency (MHz)	Efficiency (%)	Average Gain (dB)	Peak Gain (dBi)	Impedance	Polarization	Radiation Pattern	Max. input power
Wi-Fi - 2GHz	2400-2500	58.9	-2.30	1.78	50 Ω	Linear	Omni	2W

Mechanical	
Dimensions (mm)	8.0 x 2.0 x 2.0
Material	Ceramic
Weight (g)	0.11

Environmental	
Temperature Range	-40°C to 85°C
Storage Temperature	-40°C to 105°C
Temperature Coefficient (τf)	0 ± 20 ppm @-20°C to +80°C
Recommended Reel Storage Condition	5°C to 40°C Relative Humidity 20% to 70%
Moisture Sensitivity Level	3 (168 Hours)

3. Antenna Characteristics

3.1 Test Setup

AUT



Vector Network Analyzer

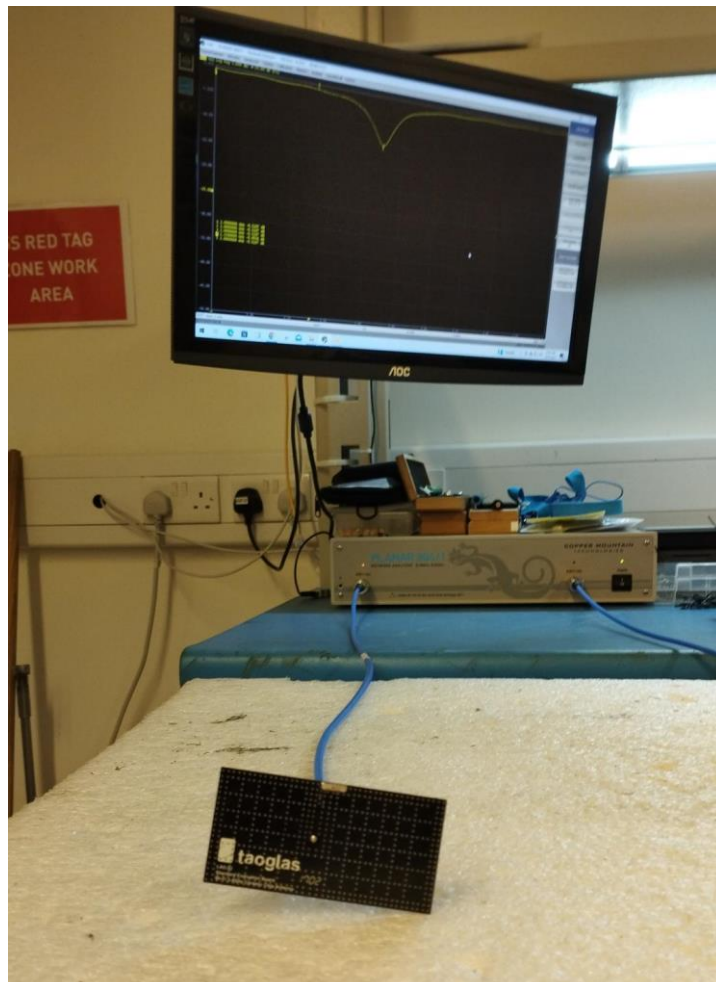

3.2 Return Loss

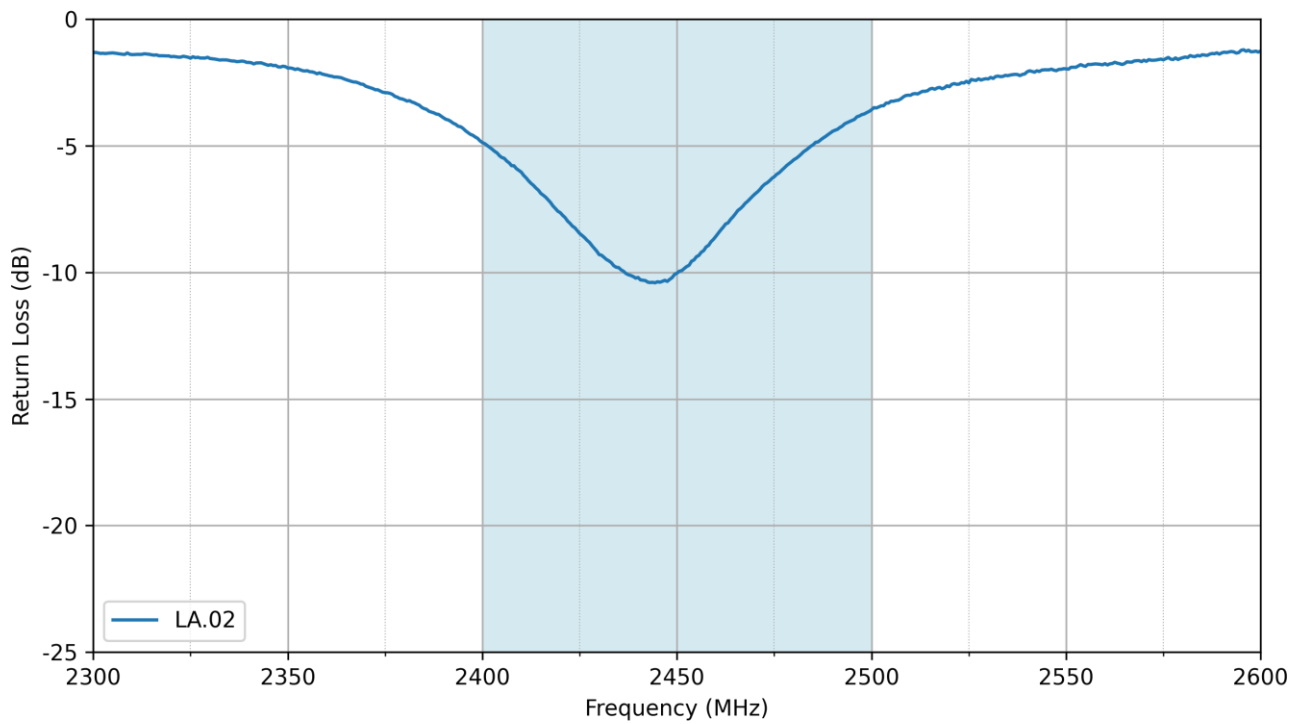

3.3 Efficiency

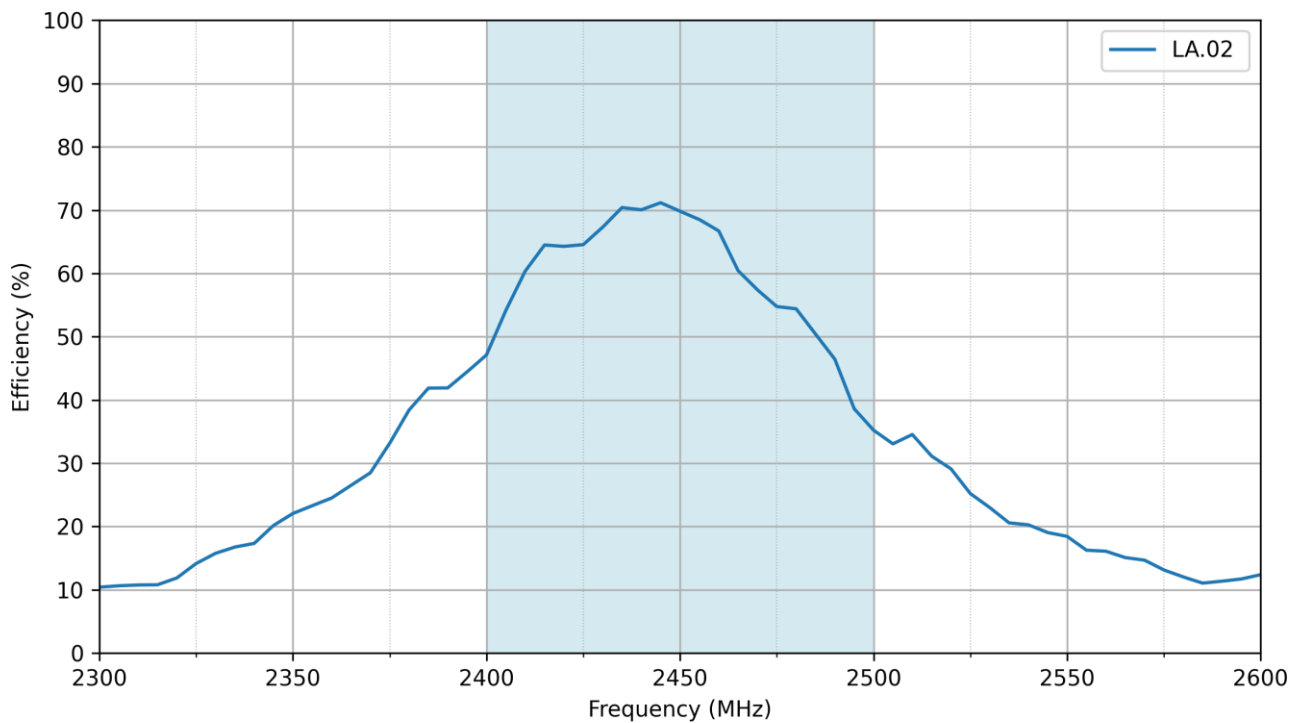

3.4 Average Gain

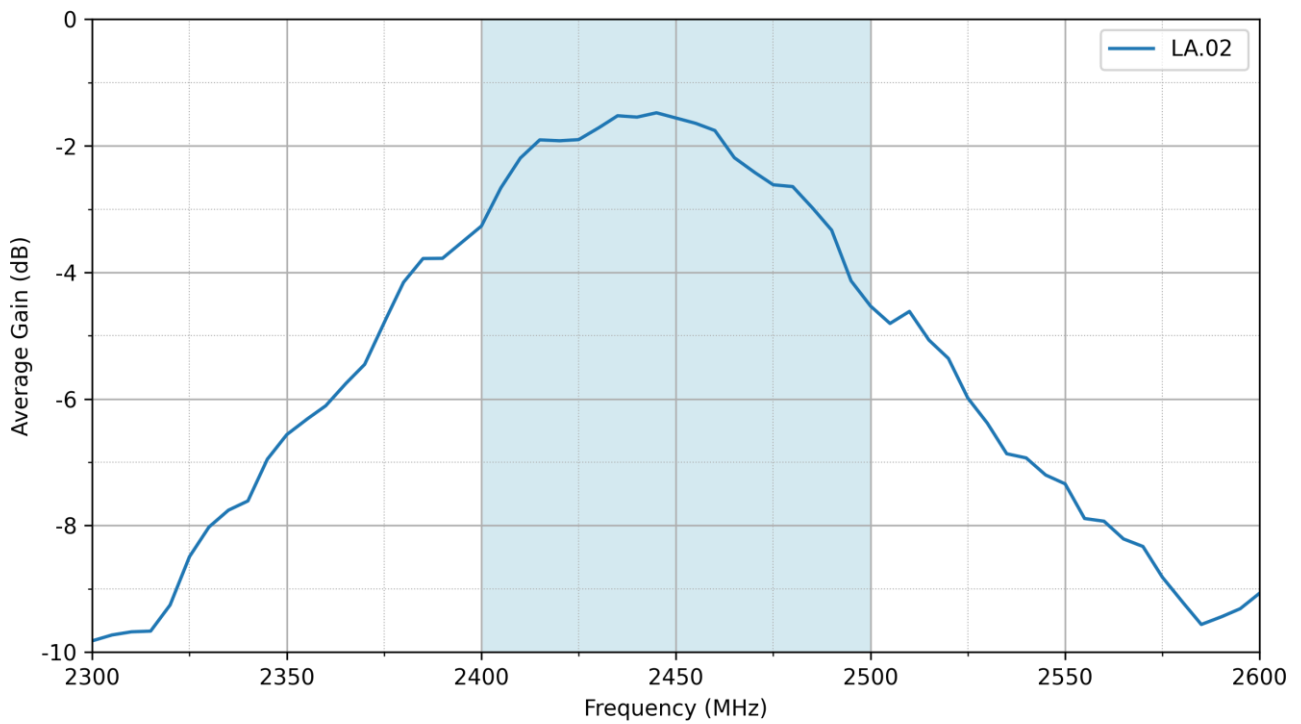

3.5 Peak Gain

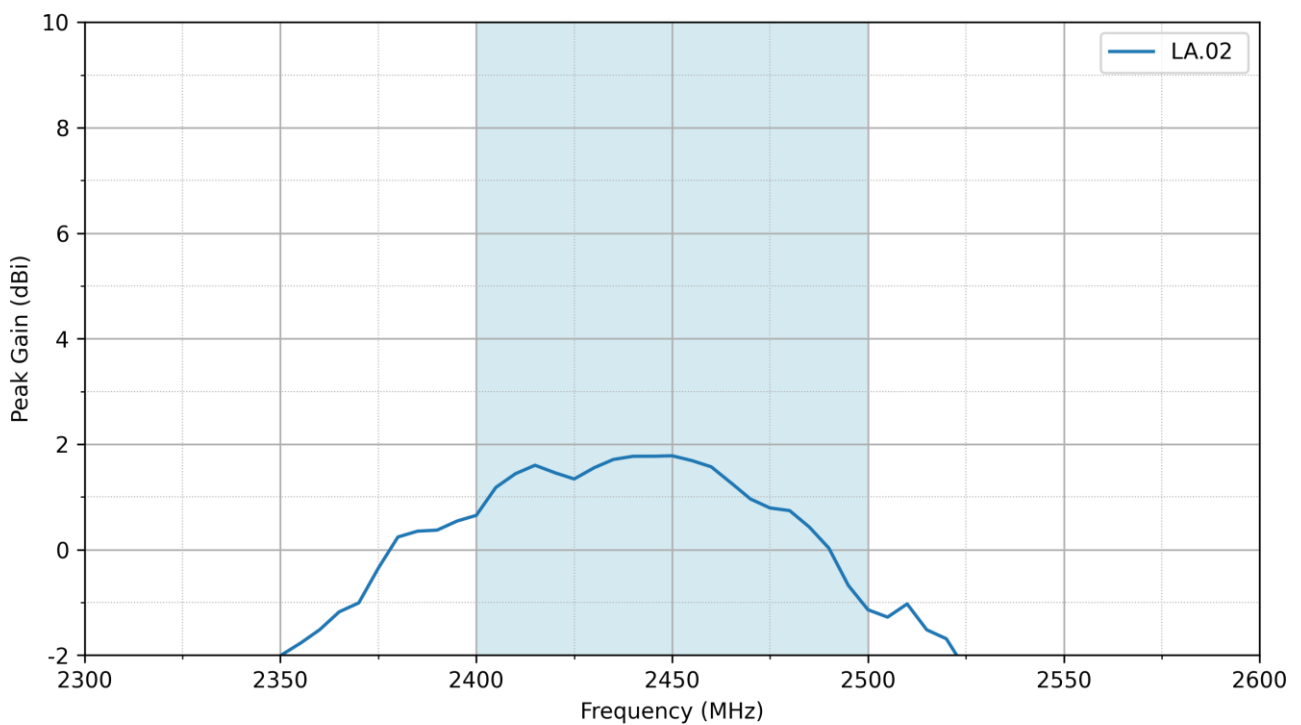

4. Radiation Patterns

4.1 Test Setup

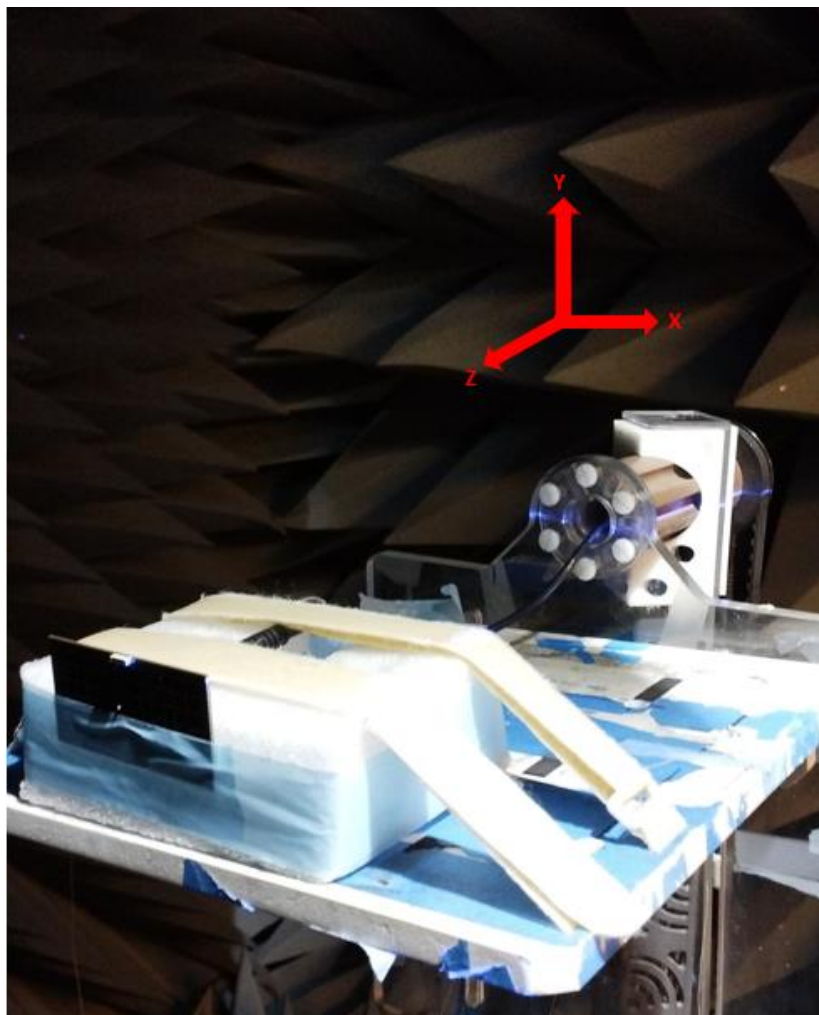
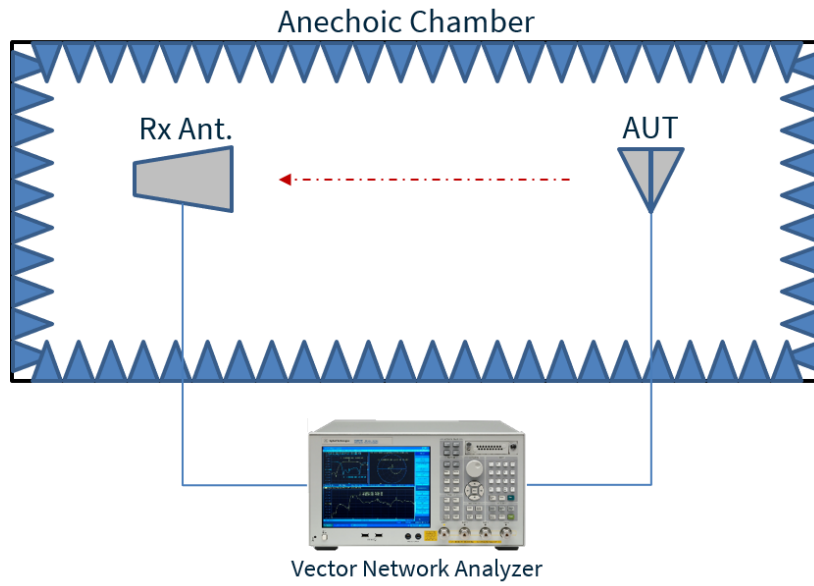

4.2 LA.02 Patterns at 2400 MHz

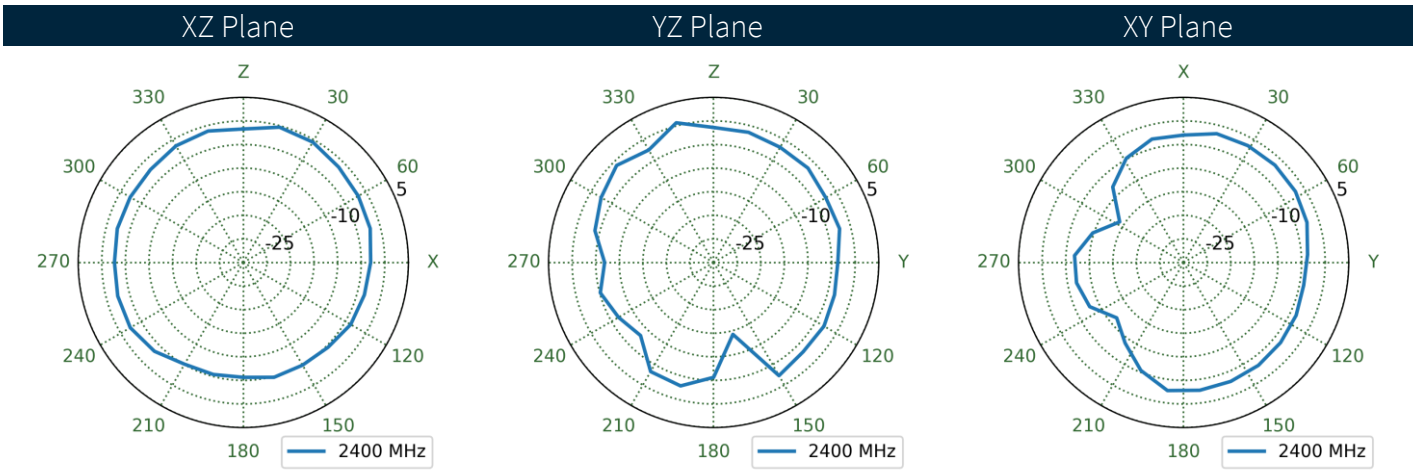
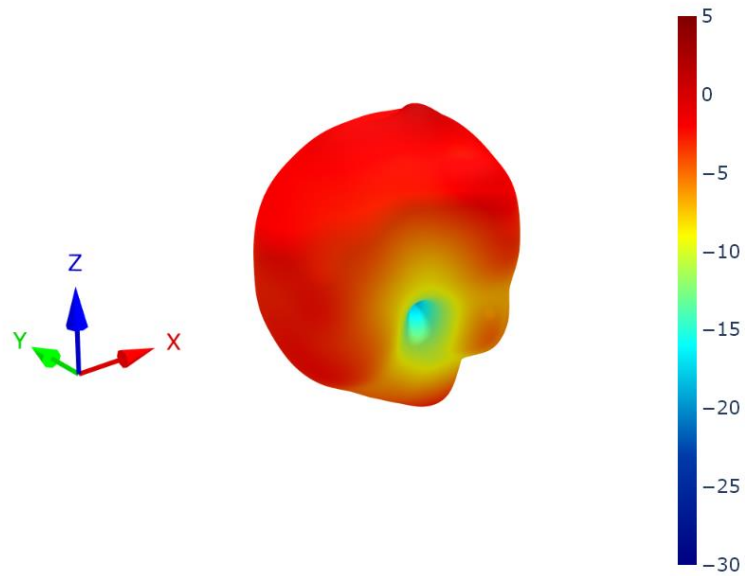

4.3 LA.02 Patterns at 2450 MHz

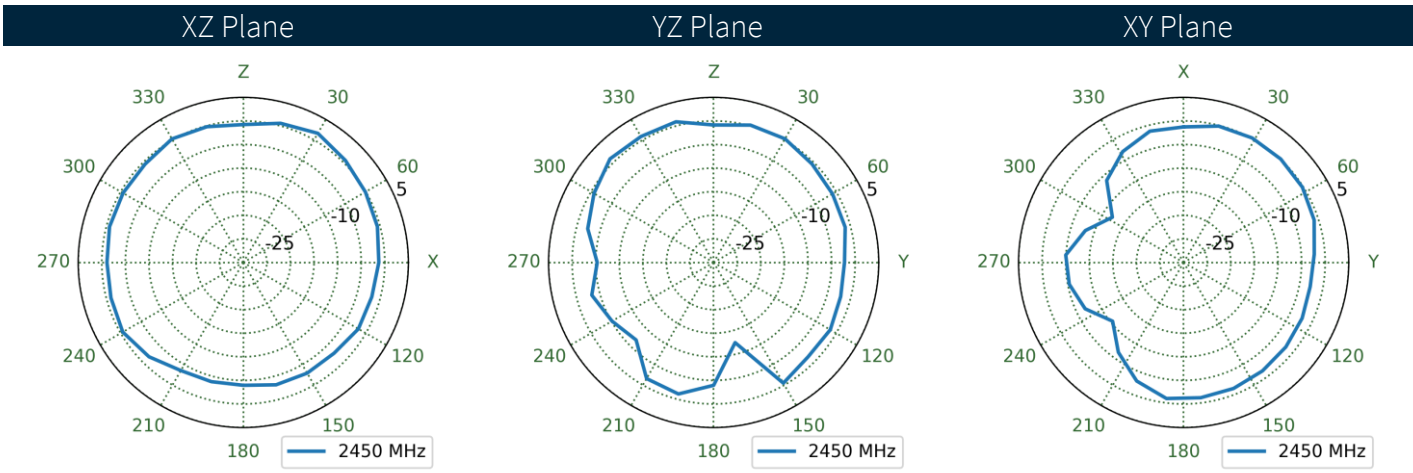
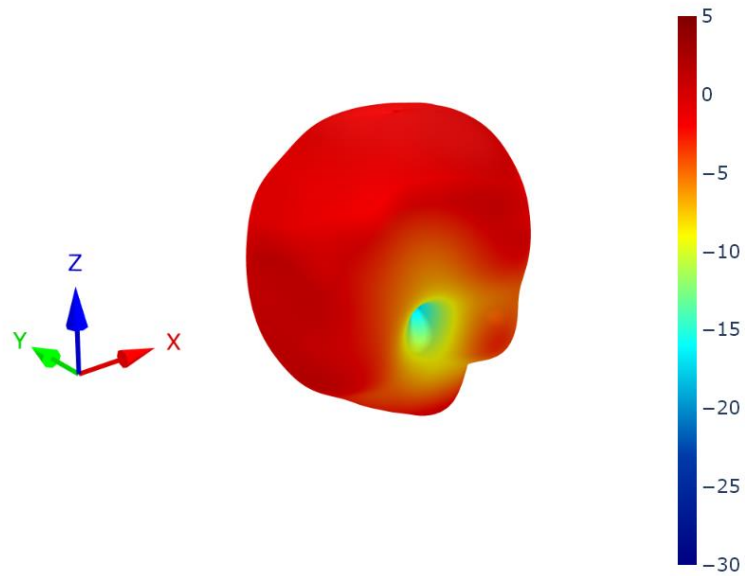

4.4 LA.02 Patterns at 2500 MHz

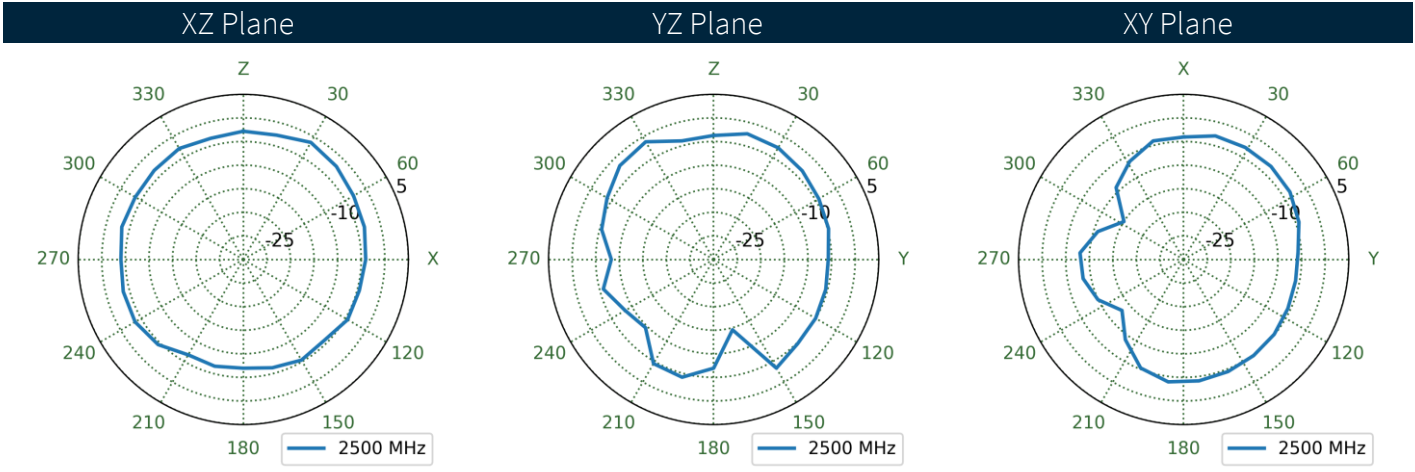
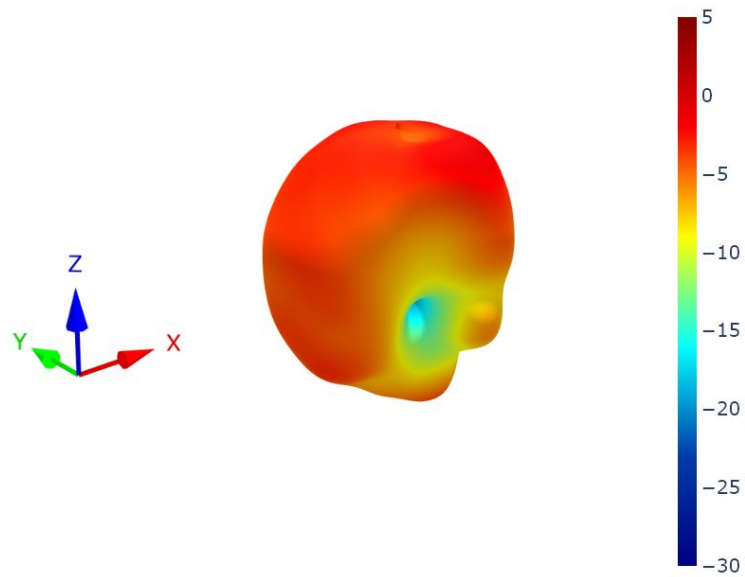

5. Mechanical Drawing

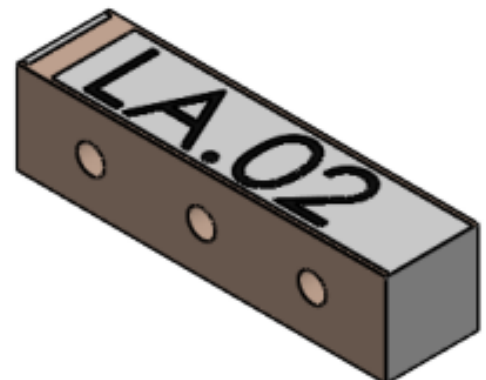
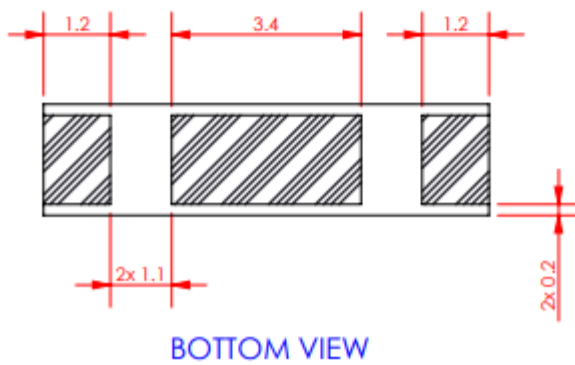
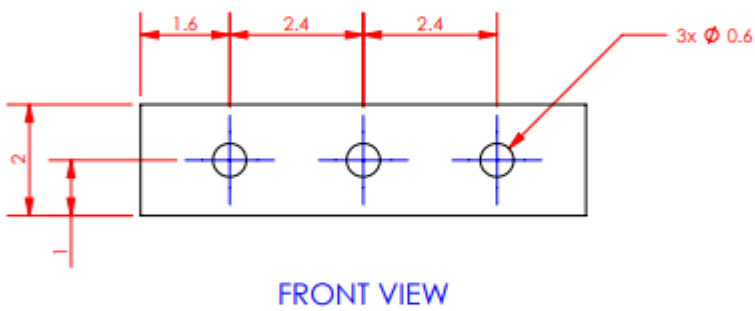
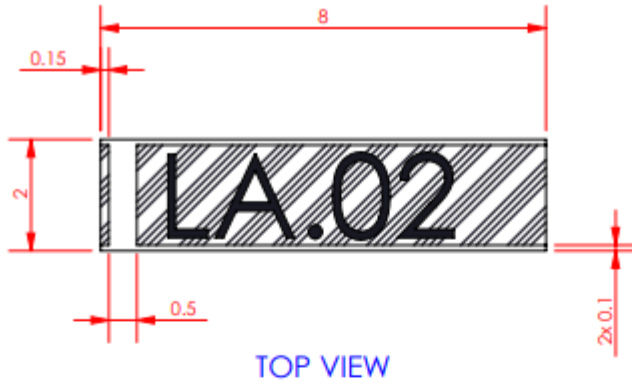

6. Antenna Integration Guide

The following is an example on how to integrate the LA.02 into a design. This antenna has 4 pins, where one pin is used for the RF Feed. Taoglas recommends using a minimum of 80x40mm ground plane (PCB) to ensure optimal performance.

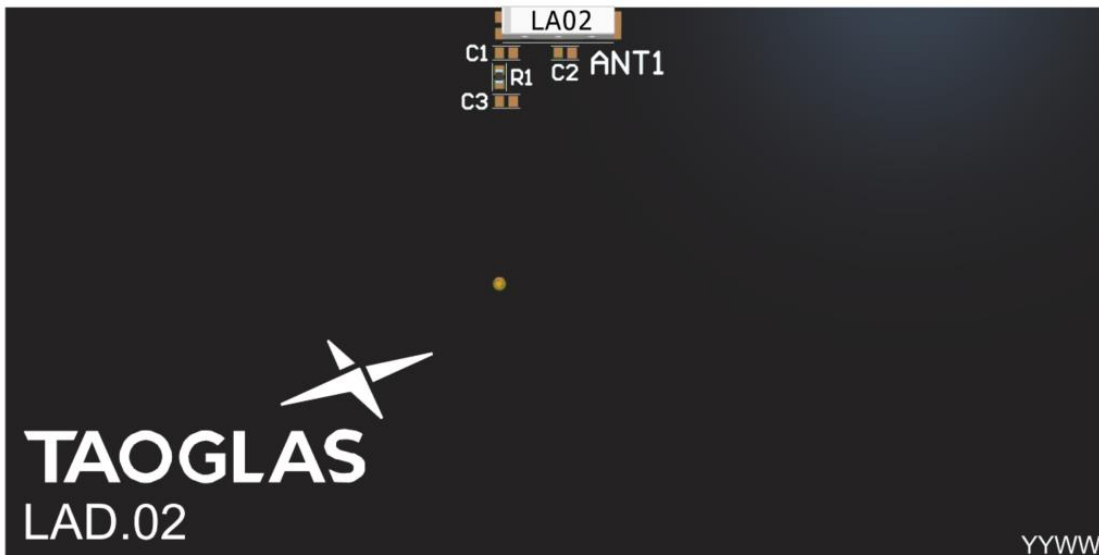

Top view of PCB.

Please find the Integration files in Altium, 2D formats and the 3D model for the LA.02 here:
<https://www.taoglas.com/product/la-02-2-4ghz-embedded-loop-antenna/>

6.1 Schematic and Symbol Definition

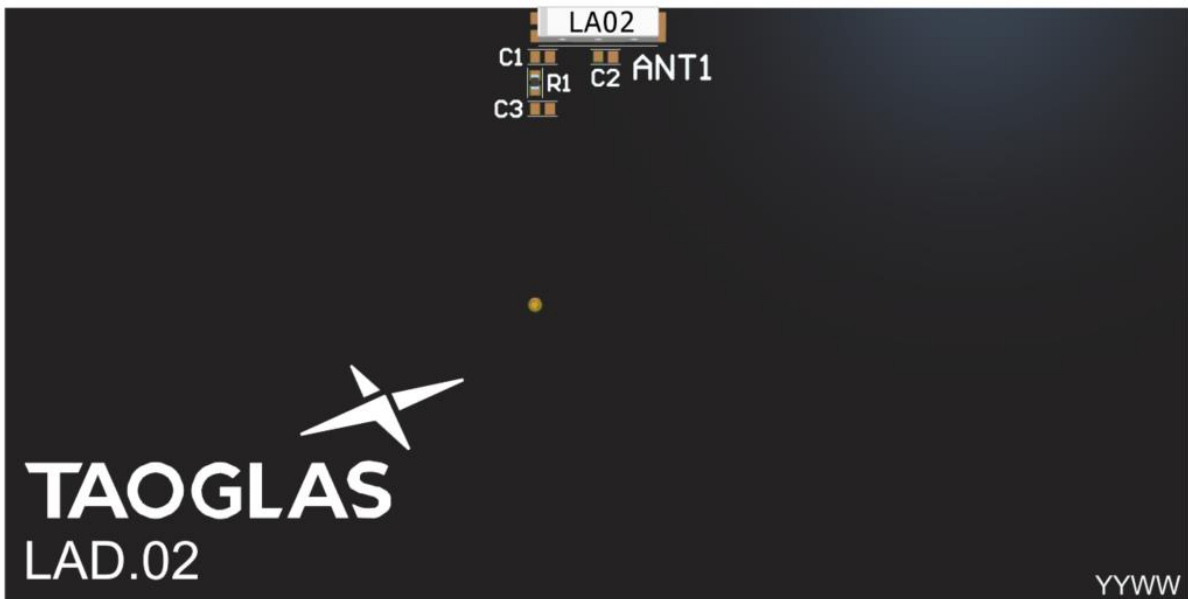

Above is a 3D model of the LA.02 on a PCB.

The circuit symbol for the LA.02 is shown below. The antenna has 4 pins as indicated below.

Pin	Description
1	RF Feed
2	Fine Tuning Element
3, 4	Ground

TAOGLAS_LA.02
ANT1

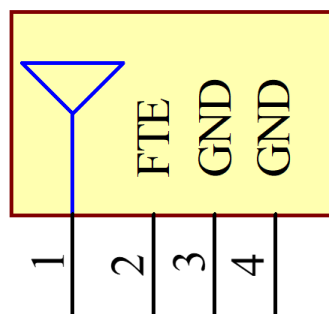

6.2 Schematic Layout

Matching components with the LA.02 are required for the antenna to have optimal performance in the spaces specified in the schematic below. Additional matching components may be necessary for your device, Taoglas recommends incorporating extra component footprints, forming a “Pi” network, for the LA.02.

Designator	Type	Value	Manufacturer	Manufacturer Part Number
R1	Resistor	0 Ohms	YAGEO	RC0402JR-070RL

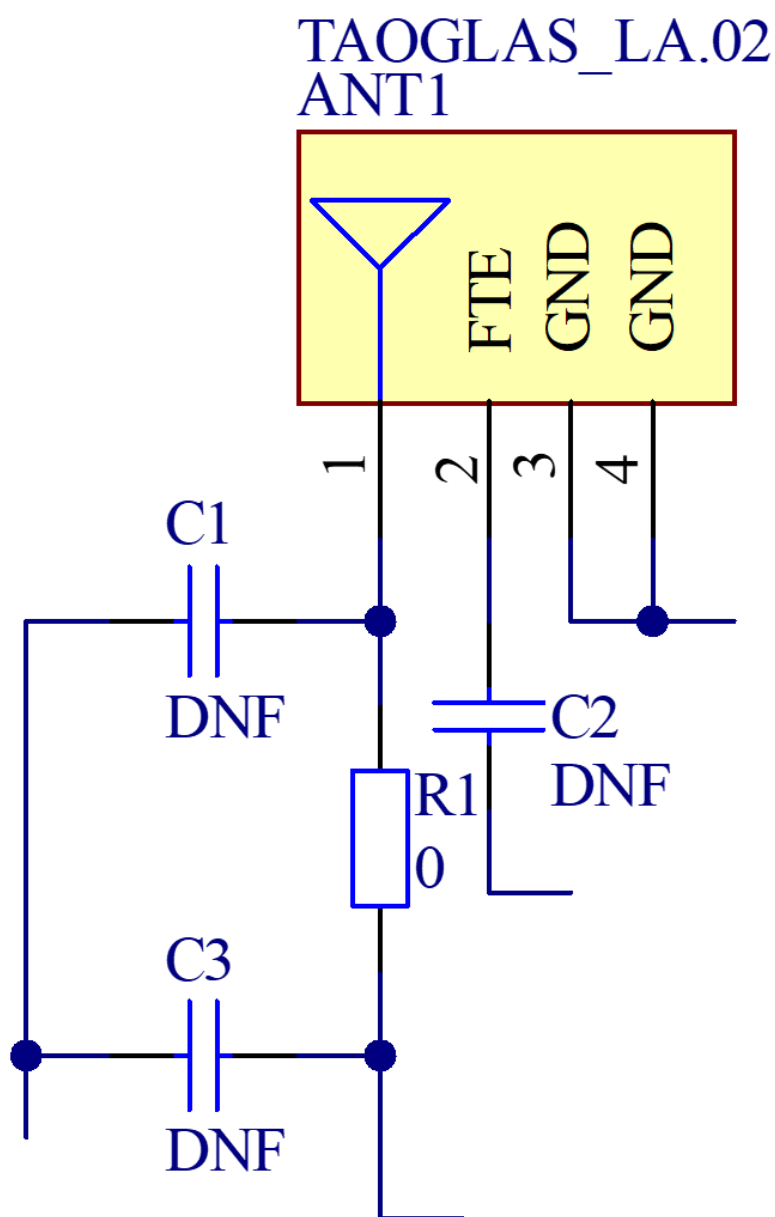

6.3 Antenna Footprint

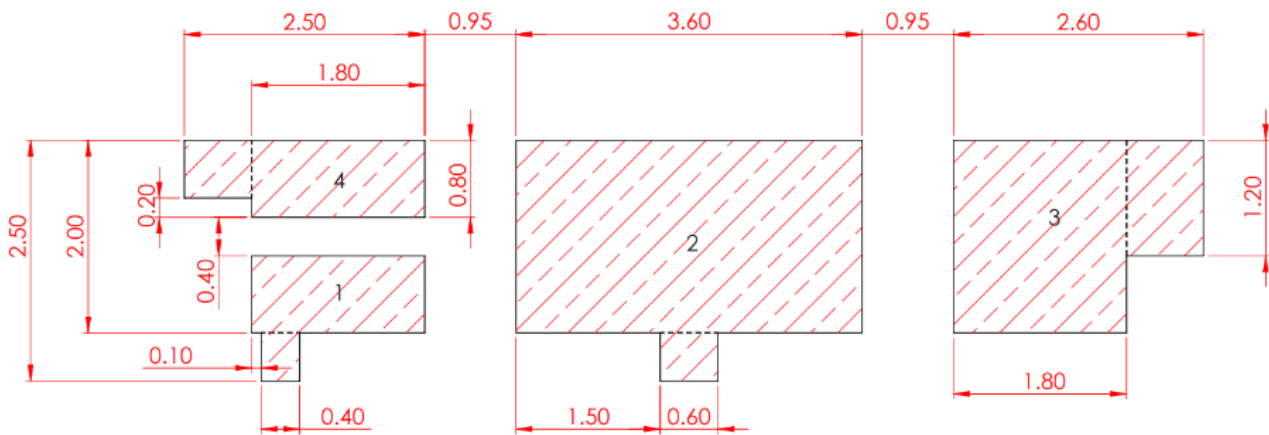

Pin	Description
1	RF Feed
2	Fine Tuning Element
3, 4	Ground

6.4 Copper Clearance for LA.02

The footprint and clearance on the PCB must comply with the antenna's specification. The PCB layout shown in the diagrams below demonstrates the LA.02 clearance area. The copper keep out area applies to all layers that are below the LA.02.

There should be 0.7mm copper clearance on the left-hand side of the antenna and a 0.8mm copper clearance on the right-hand side between the antenna sides and the ground plane with a 0.5mm copper clearance from the ground plane below the antenna. The PCB Edge Clearance should be a minimum of 0.1mm and a maximum of 0.5mm, example below is 0.3mm.

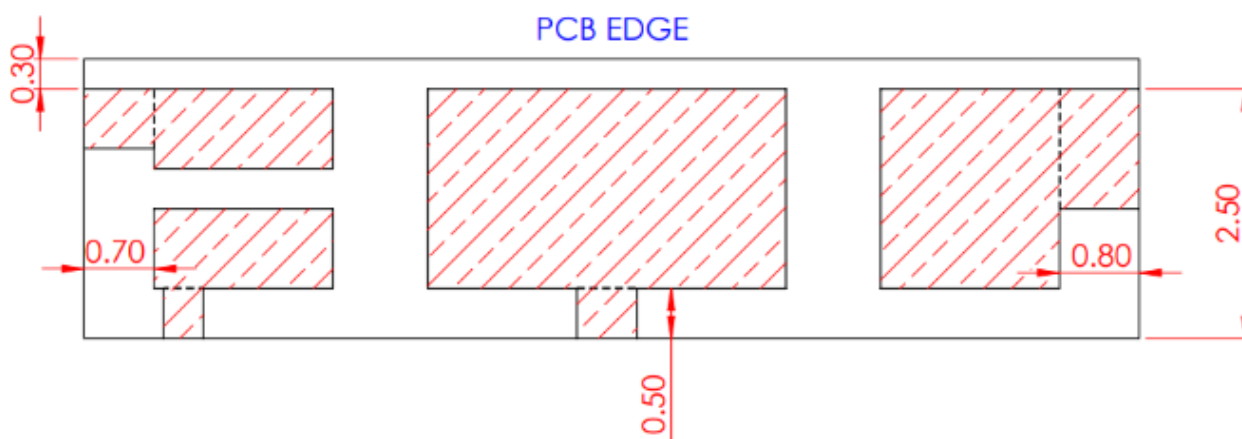

6.5 Antenna Integration

The LA.02 should be placed in the centre, as close to the edge on the long side of the PCB as possible, to take advantage of the ground plane. The RF trace must maintain a 50 Ohm transmission line. A "Pi" Matching Network is recommended for the RF transmission line, the values and components for the matching circuit will depend on the tuning needed. Ground vias should be placed around the copper clearance area.

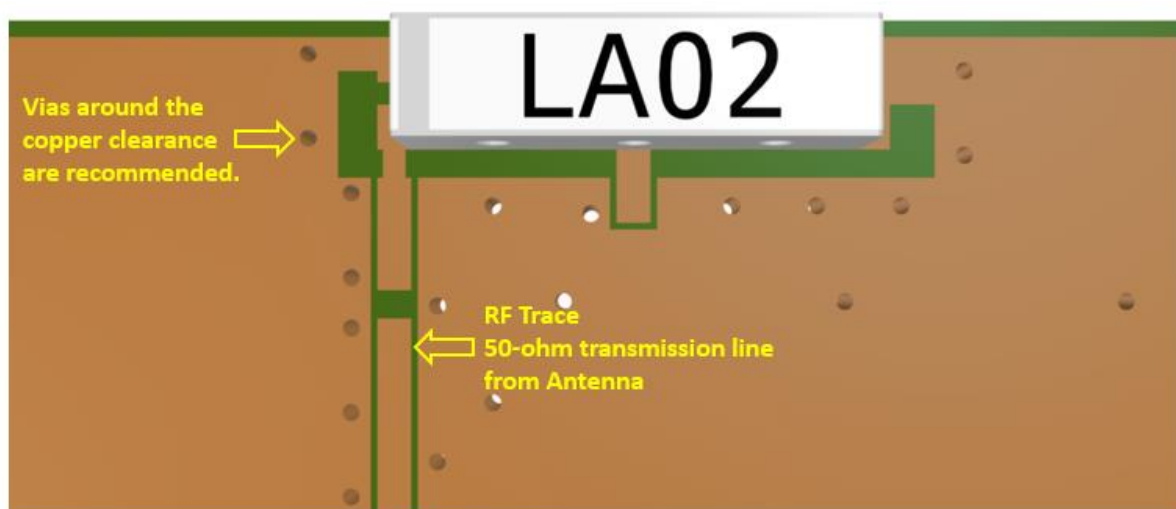

6.6 Final Integration

The top side image shown below highlights the antenna transmission line. Taoglas recommends using a minimum of 80x40mm ground plane (PCB) to ensure optimal performance.

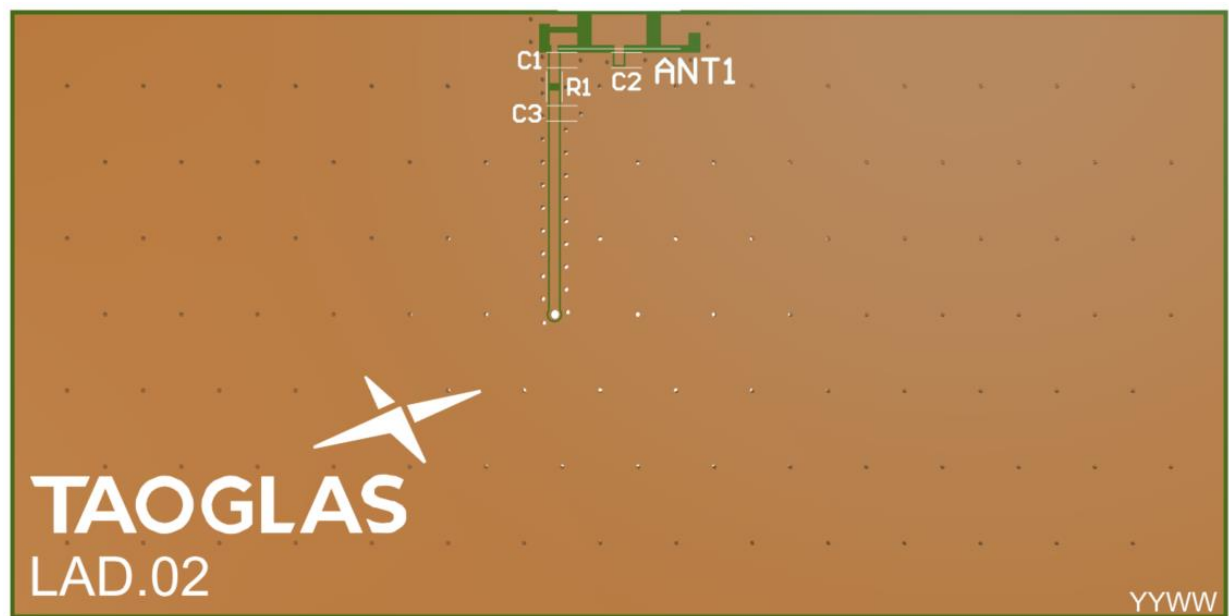
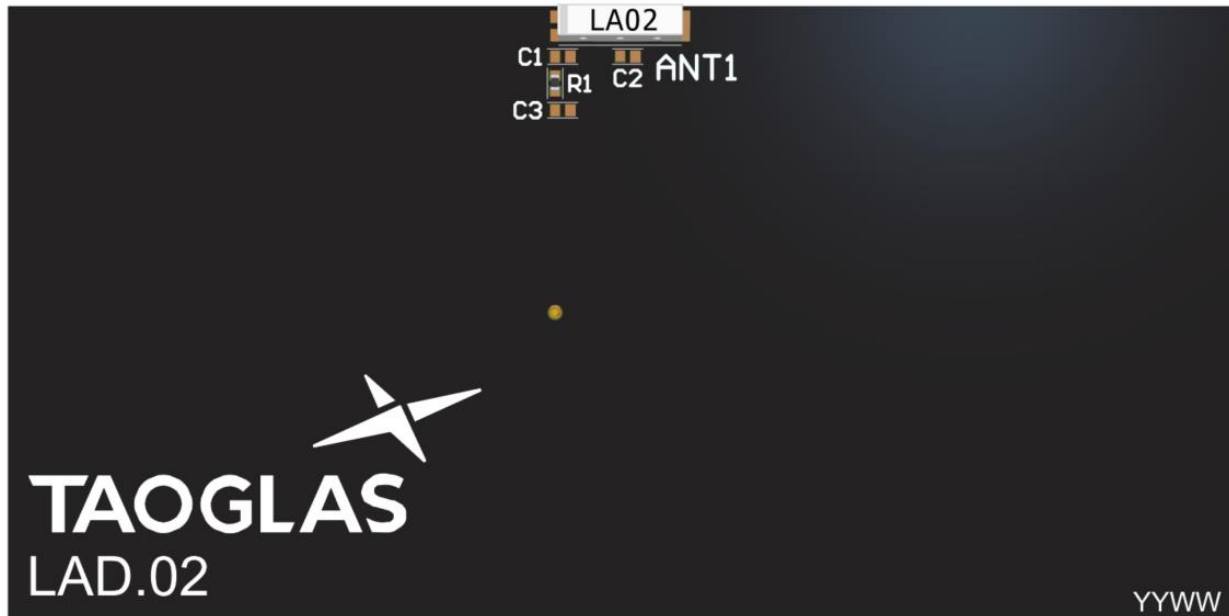

Top Side (LA.02 placement on 80x40mm PCB)

7. Solder Reflow Profile

The LA.02 can be assembled by following the recommended soldering temperatures are as follows:

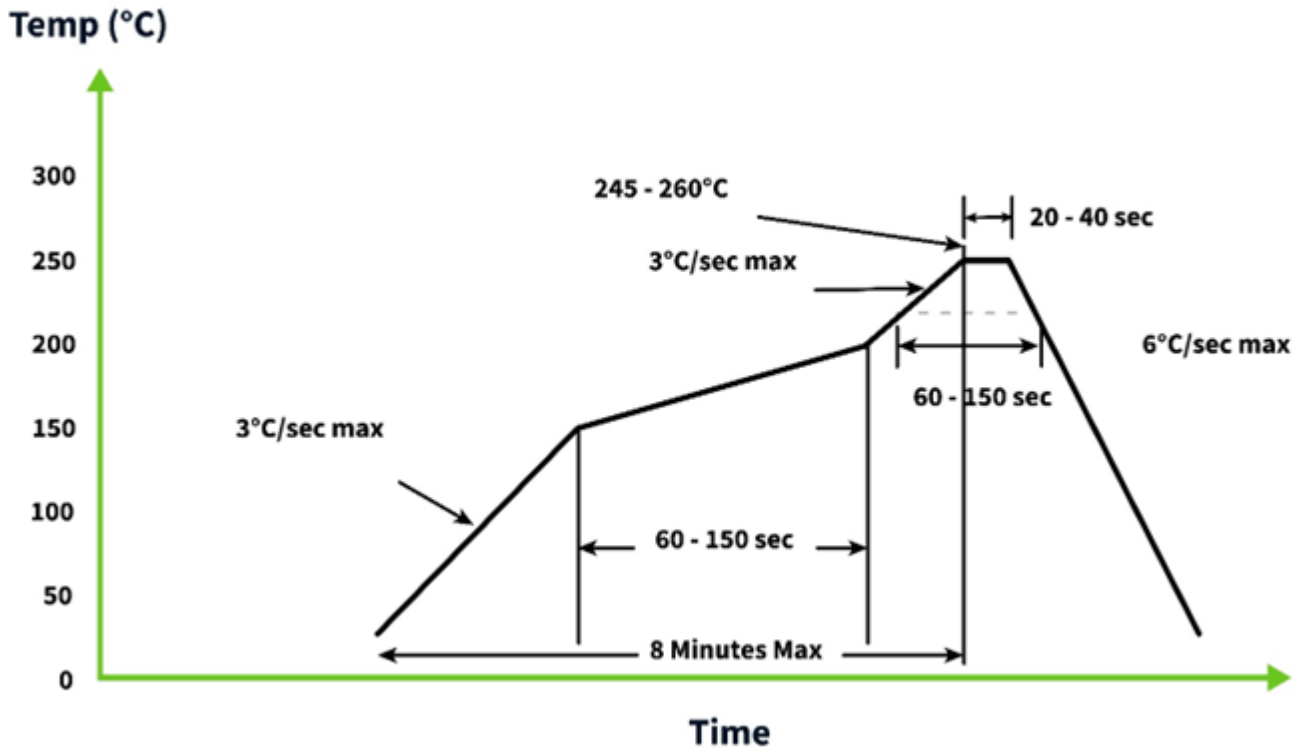

*Temperatures listed within a tolerance of +/- 10° C

Smaller components are typically mounted on the first pass, however, we do advise mounting the LA.02 when placing larger components on the board during subsequent reflows.

Note: Soldering flux classified ROL0 under IPC J-STD-004 is recommended.

8. Packaging

IEC 286-3 : Polyester Blister Tape Reel
 2,000 Pieces LA.02
 Dimensions - Diameter 330*18mm
 Weight - 650g

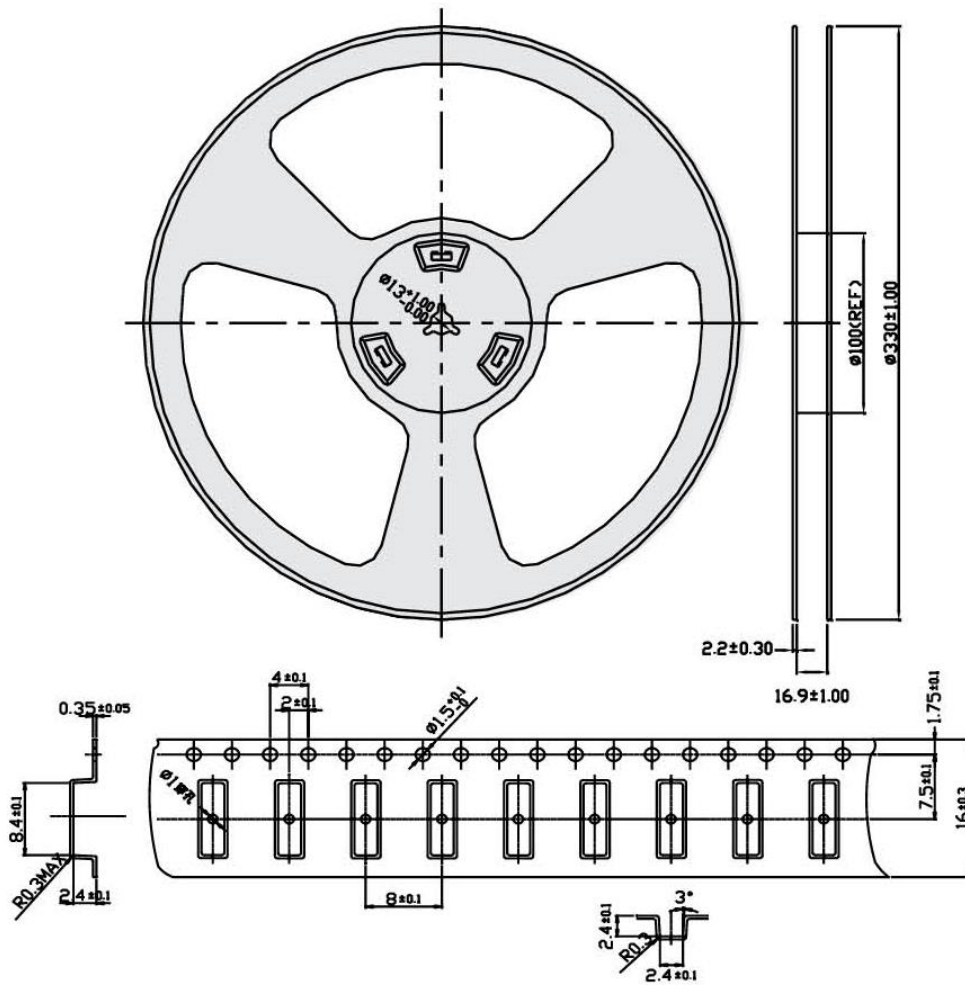

1 pc reel in small inner box
Dimensions - 350*340*47mm
Weight - 1Kg

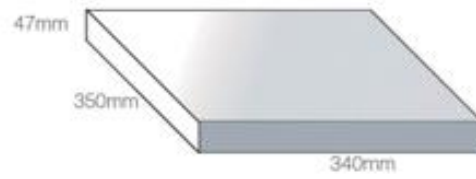

5 Reels / 10,000 pcs in one carton
Carton Dimensions - 360*370*275mm
Weight - 6Kg

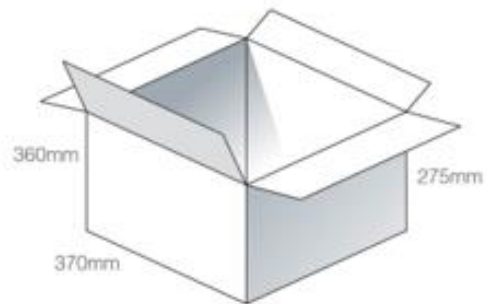

Pallet Dimensions 1100*1100*1550mm
45 Cartons per Pallet
9 Cartons per layer
5 Layers

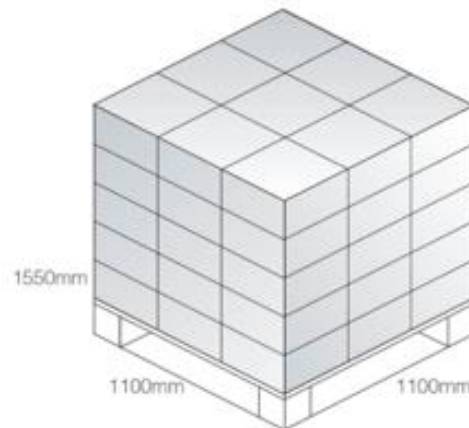

Changelog for the datasheet

SPE-15-8-040 – LA.02

Revision: G (Current Version)

Date:	2023-12-13
Changes:	Updated integration guide.
Changes Made by:	Gary West

Previous Revisions

Revision: F

Date:	2023-05-09
Changes:	Updated Solder Reflow Information
Changes Made by:	Cesar Sousa

Revision: A (Original First Release)

Date:	2016-06-17
Notes:	Initial Release
Author:	STAFF

Revision: E

Date:	2023-03-31
Changes:	Full datasheet update
Changes Made by:	Cesar Sousa

Revision: D

Date:	2023-03-13
Changes:	Added Antenna Integration Guide
Changes Made by:	Cesar Sousa

Revision: C



Date:	2021-11-1
Changes:	Format Change, MSL
Changes Made by:	Erik Landi

Revision: B

Date:	2021-05-18
Changes:	Amended Footprint drawing
Changes Made by:	Erik Landi

Looking for pricing, stock, or lifecycle information?

Click below to explore more details on WIN SOURCE:

-  [View LA.02 on WIN SOURCE](#)
-  [Taoglas Limited Information](#)

Optimize Your Supply Chain with WIN SOURCE Solutions

-  Global Sourcing Solution
-  Obsolete Management
-  Cost Control Management
-  Shortage Management
-  Alternative Solution
-  Excess Inventory Management