



**THE DATASHEET OF  
ISL99227IRZ**



ISL99227, ISL99227B

Smart Power Stage (SPS) Module with Integrated High Accuracy Current and Temperature Monitors

The [ISL99227](#) and [ISL99227B](#) are Smart Power Stage (SPS) compatible with the ISL68xxx/69xxx Digital Multiphase (DMP) controllers and phase doubler (ISL6617A), respectively. The ISL99227 and ISL99227B have integrated high accuracy current and temperature monitors that can be fed back to the controller and doubler to complete a multiphase DC/DC system. They simplify design and increase performance by eliminating the DCR sensing network and associated thermal compensation. Light-load efficiency is supported through a dedicated LFET control pin. An industry leading thermally enhanced 5x5 PQFN package allows minimal overall PCB real estate.

The ISL99227 and ISL99227B feature a 3.3V compatible, 5.0V compatible tri-state PWM input that, working together with Renesas multiphase PWM controllers, provide a robust solution in the event of abnormal operating conditions. The ISL99227 and ISL99227B also improve system performance and reliability with integrated fault protection of UVLO, over-temperature, and overcurrent. An open-drain fault reporting pin simplifies the handshake between SPS and Renesas controllers and can be used to disable the controller during start-up and fault conditions.

**Related Literature**

- For a full list of related documents, visit our website
  - [ISL99227](#), [ISL99227B](#) product pages

**Features**

- Input range: +4.5V to +18V
- Supports 60A DC current
- ISL99227 with 3.3V compatible tri-state PWM input
- ISL99227B with 5.0V compatible tri-state PWM input
- Downslope current sensing
- ±3% accuracy current monitor (IMON) with REFIN input
- 8mV/°C temperature monitor with OT flag
- Dedicated low-side FET control input
- Comprehensive fault protection for high system reliability
  - High-side FET short and overcurrent protection
  - Over-temperature protection
  - V<sub>CC</sub> and V<sub>IN</sub> Undervoltage Lockout (UVLO)
- Open-drain fault reporting output
- Up to 2MHz switching frequency
- RoHS compliant with Exemption 7a, 32 Ld 5x5 PQFN

**Applications**

- High frequency and high efficiency VRM and VRD
- Core, graphic, and memory regulators for microprocessors
- High density VR for server, networking, and cloud computing
- POL DC/DC converters and video gaming consoles

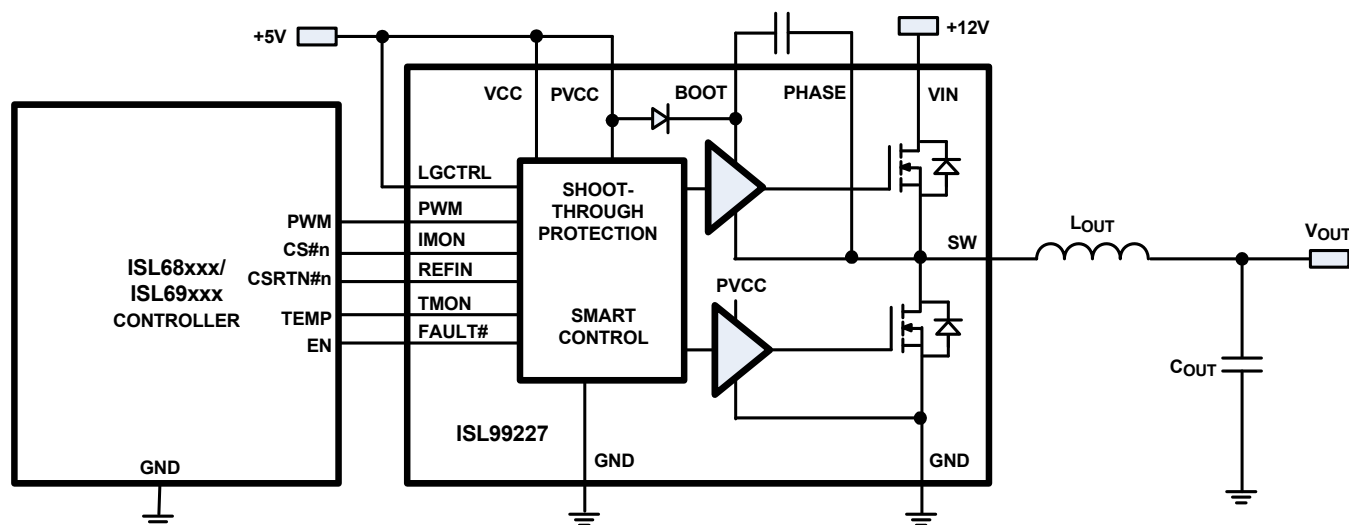

FIGURE 1. ISL99227 SIMPLIFIED APPLICATION BLOCK DIAGRAM



# Typical Application Circuit with ISL99227B and ISL6617A

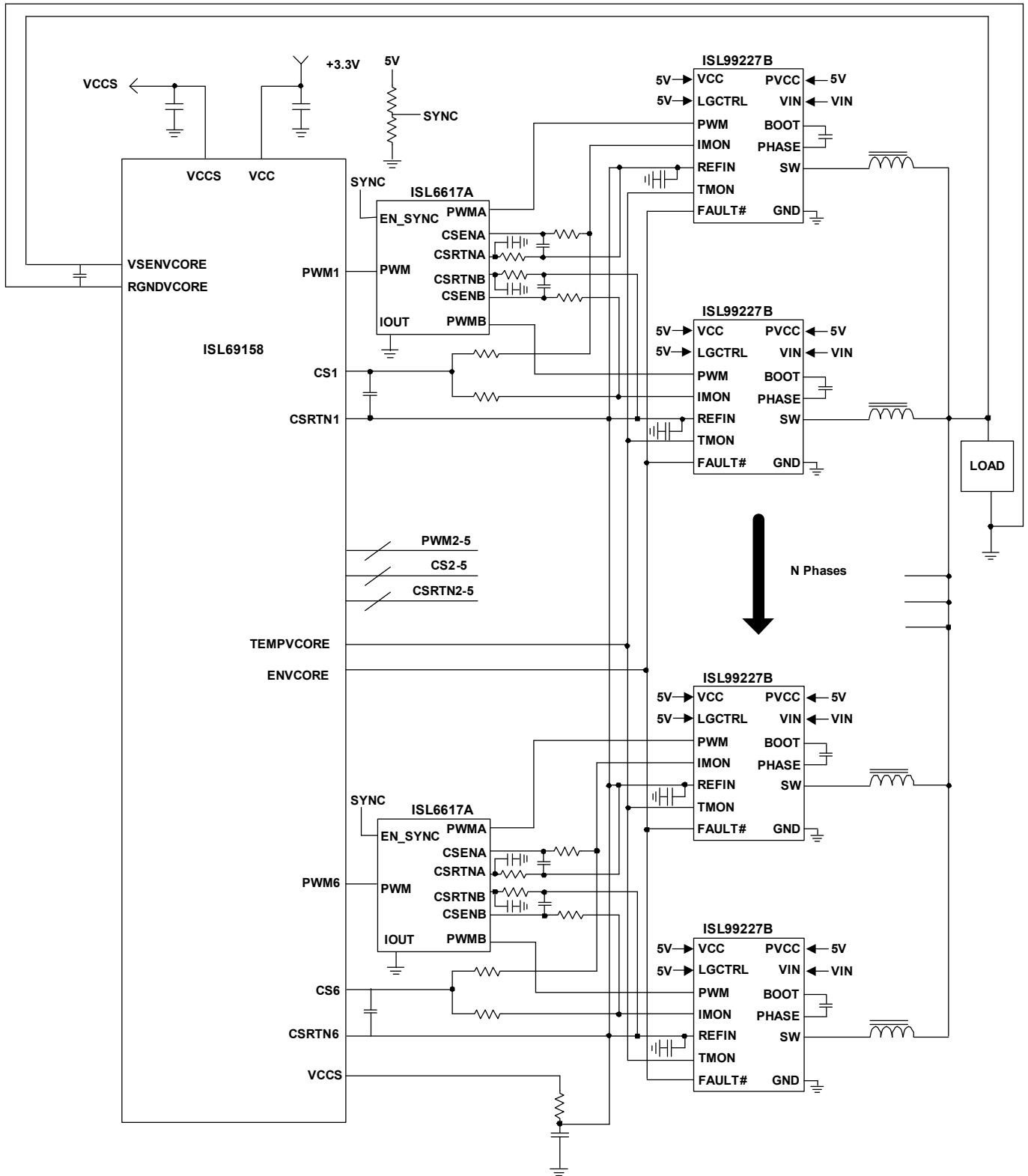

FIGURE 3. TYPICAL APPLICATION CIRCUIT WITH ISL99227B (COMPATIBLE WITH ISL6617A 5V PWM OUTPUT)

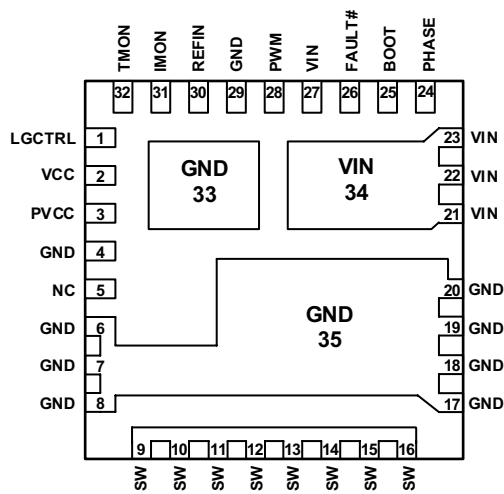

**TABLE 1. KEY DIFFERENCES BETWEEN FAMILY OF PARTS**

PART #	CURRENT RATING (A)	PWM (V)	THERMAL FLAG	OCP FLAG	IMON	TMON	PACKAGE	P2P COMPATIBLE	USED WITH
<b>5.0V PWM POWER STAGE FAMILY</b>									
ISL99125B	25	5.0	No	No	No	No	24 Ld 3.5x5 QFN	ISL99135B	Analog Controllers: ISL633x, ISL636x, ISL637x, ISL95829, ISL9585x Digital Hybrid Controllers: ISL68201, ISL6388/98 Full Digital Controller: ZL8802 Phase Doublers: ISL6617, ISL6617A (see <a href="#">Figure 3 on page 3</a> )
ISL99135B	35	5.0	No	No	No	No	24 Ld 3.5x5 QFN	ISL99125B	
ISL99227B	60	5.0	Yes	Yes	Yes	Yes	32 Ld 5x5 PQFN	N/A	
<b>3.3V PWM POWER STAGE FAMILY</b>									
ISL99140	40	3.3	Yes	No	No	No	40 Ld 6x6 QFN	N/A	Full Digital Controllers: ISL68/69xxx (see <a href="#">Figure 2 on page 2</a> ), ZL8802 Digital Hybrid Controller: ISL68201, ISL6388/98 (3.3V PWM Setting)
ISL99227	60	3.3	Yes	Yes	Yes	Yes	32 Ld 5x5 PQFN	N/A	

## Pin Configuration

ISL99227, ISL99227B  
(32 LD PQFN)  
TOP VIEW



## Pin Descriptions

PIN #	PIN NAME	DESCRIPTION
1	LGCTRL	Lower gate control signal input. LO = GL low (LFET off). HI = Normal operation (GL and GH strictly obey PWM). This pin should be driven with a logic signal, or externally tied high if not required; it should NOT be left floating.
2	VCC	+5V logic bias supply. Place a high quality low ESR ceramic capacitor (~1 $\mu$ F/X7R) in close proximity from this pin to GND.
3	PVCC	+5V gate drive bias supply. Place a high quality low ESR ceramic capacitor (~1 $\mu$ F/X7R) in close proximity from this pin to GND.
4, 6, 7, 8, 17, 18, 19, 20, 29 PAD 33, PAD 35	GND	All GND pins are internally connected. Pins 4 and 29 should be connected directly to the nearby GND paddles on the package bottom. <a href="#">Figure 15 on page 14</a> shows GND paddles should be connected to the system GND plane with as many vias as possible to maximize thermal and electrical performance.
5	NC	No connect (this is a low-side gate driver output (GL), optional to monitor for system debugging).
9, 10, 11, 12, 13, 14, 15, 16	SW	Switching junction node between HFET source and LFET drain. Connect directly to output inductor.
21, 22, 23, 27, PAD 34	VIN	Input of power stage (to drain of HFET). Place at least 2 ceramic capacitors (10 $\mu$ F or higher, X5R or X7R) in close proximity across VIN and GND. Pin 27 should NOT be used for decoupling. For optimal performance, place as many vias as possible in the bottom side VIN paddle.
24	PHASE	Return of boot capacitor. Internally connected to SW node so no external routing required for SW connection.
25	BOOT	Floating bootstrap supply pin for the upper gate drive. Place a high quality low ESR ceramic capacitor (0.1 $\mu$ F~0.22 $\mu$ F/X7R) in close proximity across BOOT and PHASE pins.
26	FAULT#	Open-drain output pin. Any fault (overcurrent, over-temperature, shorted HFET, or POR/UVLO) will pull this pin to ground. This pin can be connected to the controller Enable pin or used to signal a fault at the system level.
28	PWM	ISL99227: PWM input of gate driver, compatible with 3.3V tri-state PWM signal. ISL99227B for 5V PWM.
30	REFIN	Input for external reference voltage for IMON signal. This voltage should be between 0.8V and 1.6V. Connect REFIN to the appropriate current sense input of the controller. Place a high quality low ESR ceramic capacitor (~ 0.1 $\mu$ F) in close proximity from this pin to GND.
31	IMON	Current monitor output, referenced to REFIN. IMON will be pulled high (to REFIN + 1.2V) to indicate an HFET shorted or overcurrent fault. Connect the IMON output to the appropriate current sense input of the controller. No more than 56pF capacitance can be directly connected across IMON and REFIN pins. Typically, a 100 $\Omega$ series resistor and 470pF is recommended.
32	TMON	Temperature monitor output. For multiphase, the TMON pins can be connected together as a common bus; the highest voltage (representing the highest temperature) will be sent to the PWM controller. TMON will be pulled high (to 2.5V) to indicate an over-temperature fault. No more than 470pF total capacitance can be directly connected across the TMON and GND pins; with a series resistor, a higher capacitance load is allowed, such as 1k $\Omega$ for 100nF load.

## Absolute Maximum Ratings

Supply Voltage (VCC, PVCC)	-0.3V to 6V
Input Supply Voltage (VIN)	-0.3V to 25V
PHASE, SW Voltage (V <sub>PH-GND</sub> , V <sub>SW-GND</sub> )	-0.3V to 25V GND - 10V (<20ns Pulse Width, 10μJ)
BOOT Voltage (V <sub>BOOT-GND</sub> )	-0.3V to 36V
Other I/O Pin Voltage	-0.3V to VCC + 0.3V
<b>ESD Ratings</b>	
Human Body Model (Tested per JEDEC-JS-001-2014)	2.5kV
Charged Device Model (Tested per JS-002-2014)	1kV
Machine Model (Tested per JESD22-A115C)	250V
Latch-Up (Tested per JESD-78E; Class 2, Level A)	100mA

## Thermal Information

Thermal Resistance	$\theta_{JA}$ (°C/W)	$\theta_{JC}$ (°C/W)
32 Ld 5x5 PQFN		
Double Cooling Package (Notes 4, 5, 7)	10.7	4
Maximum Junction Temperature (Plastic Package)	+150°C	
Maximum Storage Temperature Range	-65°C to +150°C	
Pb-Free Reflow Profile	see <a href="#">TB493</a>	

## Recommended Operating Conditions

<b>Operating Junction Temperature Range</b>		
IRZ	-40°C to +85°C	
HRZ	-10°C to +100°C	
FRZ	-40°C to +125°C	
Supply Voltage, VCC, PVCC	5V ±5%	
Input Supply Voltage, VIN	4.5V to 18V	

**CAUTION:** Do not operate at or near the maximum ratings listed for extended periods of time. Exposure to such conditions may adversely impact product reliability and result in failures not covered by warranty.

### NOTES:

- $\theta_{JA}$  is measured in free air with the component mounted on an SPS evaluation board. Refer to Tech Brief [TB379](#) for general thermal metric info.
- For  $\theta_{JC}$ , the “case temp” location is the center of the package underside.

**Electrical Specifications** Recommended operating conditions, unless otherwise noted. **Boldface limits apply across the operating temperature range, T<sub>J</sub> = -40°C to +125°C.**

PARAMETER	SYMBOL	TEST CONDITIONS	MIN (Note 6)	TYP	MAX (Note 6)	UNIT
<b>POWER RATING</b>						
Maximum Instant Power Dissipation		T <sub>A</sub> = +25°C, 150A, (Note 7)		100		W
Maximum Continuous Power Dissipation		T <sub>A</sub> = +25°C, $\theta_{JA}$ = 10°C/W, T <sub>J</sub> = +150°C, (Note 7)		12.5		W
<b>THERMAL RESISTANCE</b>						
Thermal Resistance Junction to PCB	$\theta_{JB}$	SPS evaluation board, (Note 7)		5.2		°C/W
Thermal Resistance Junction to Ambient	$\theta_{JA}$	SPS evaluation board, (Note 7), 0 LFM		10.7		°C/W
Thermal Resistance Junction to Ambient	$\theta_{JA}$	SPS evaluation board, (Note 7), 400 LFM		9.3		°C/W
<b>VCC SUPPLY CURRENT</b>						
Logic Standby Current	IVCC	PWM = Open		4.75		mA
Gate Drive Standby Current	IPVCC	PWM = Open		100		μA
Logic Operational Current	IVCC	PWM = 300kHz		4.75		mA
Gate Drive Operational Current	IPVCC	PWM = 300kHz		15		mA
<b>POWER-ON RESET AND ENABLE</b>						
VCC Rising POR Threshold				3.86	<b>4.20</b>	V
VCC Falling POR Threshold			<b>3.20</b>	3.58		V
VCC POR Hysteresis				280		mV
VCC POR Delay to Operation				125	197	μs
VIN Rising POR Threshold				4.0	<b>4.2</b>	V
VIN Falling POR Threshold			<b>3.4</b>	3.5		V
VIN POR Hysteresis				445		mV
<b>3.3V PWM INPUT FOR ISL99227 (See “TIMING DIAGRAM” Figure 5 on page 9)</b>						
Sink Impedance				33.5		kΩ
Source Impedance				16.5		kΩ

**Electrical Specifications** Recommended operating conditions, unless otherwise noted. **Boldface limits apply across the operating temperature range,  $T_J = -40^\circ\text{C}$  to  $+125^\circ\text{C}$ .** (Continued)

PARAMETER	SYMBOL	TEST CONDITIONS	MIN (Note 6)	TYP	MAX (Note 6)	UNIT
Tri-State Lower Gate Falling Threshold		$V_{CC} = 5V$		1.11		V
Tri-State Lower Gate Rising Threshold		$V_{CC} = 5V$		0.87		V
Tri-State Upper Gate Rising Threshold		$V_{CC} = 5V$		2.13		V
Tri-State Upper Gate Falling Threshold		$V_{CC} = 5V$		1.95		V
Tri-State Shutdown Window		$V_{CC} = 5V$	<b>1.3</b>		<b>1.8</b>	V
<b>5V PWM INPUT FOR ISL99227B (See "TIMING DIAGRAM" on Figure 5 on page 9)</b>						
Sink Impedance				16.5		k $\Omega$
Source Impedance				16.5		k $\Omega$
Tri-State Lower Gate Falling Threshold		$V_{CC} = 5V$		1.51		V
Tri-State Lower Gate Rising Threshold		$V_{CC} = 5V$		1.14		V
Tri-State Upper Gate Rising Threshold		$V_{CC} = 5V$		3.24		V
Tri-State Upper Gate Falling Threshold		$V_{CC} = 5V$		3.02		V
Tri-State Shutdown Window		$V_{CC} = 5V$	<b>1.6</b>		<b>2.8</b>	V
<b>SWITCHING TIME</b>						
GH Turn-On Propagation Delay	$t_{PDHU}$	See Figure 5 (GL Low to GH High)		8		ns
GH Turn-Off Propagation Delay	$t_{PDLU}$	See Figure 5 (PWM Low to GH Low)		40		ns
GL Turn-On Propagation Delay	$t_{PDHL}$	See Figure 5 (GH Low to GL High)		8		ns
GL Turn-Off Propagation Delay	$t_{PDLL}$	See Figure 5 (PWM High to GL Low)		23		ns
GL Exit Tri-State Propagation Delay	$t_{PDTSL}$	See Figure 5 (Tri-state to GL High)		25		ns
GH Exit Tri-State Propagation Delay	$t_{PDTSU}$	See Figure 5 (Tri-state to GH High)		35		ns
PWML to Tri-State Shutdown Hold-Off Time	$t_{TSSHDL}$	See Figure 5 (PWM Low to GL Low)		40		ns
PWMH to Tri-State Shutdown Hold-Off Time	$t_{TSSHDU}$	See Figure 5 (PWM High to GH Low)		50		ns
<b>CURRENT MONITOR</b>						
REFIN Voltage Range			<b>0.8</b>	1.2	<b>1.6</b>	V
IMON Current Gain Accuracy (SPS Validation Board, $V_{CC} = 5V$ )		10A, $T_J = +90^\circ\text{C}$		$\pm 2$		%
		$\geq 10A$ , $T_J = +40^\circ\text{C}$ to $+125^\circ\text{C}$		$\pm 3$		%
		$\geq 10A$ , $T_J = +20^\circ\text{C}$ to $+125^\circ\text{C}$		$\pm 4$		%
Downslope Blanking Time				160		ns
HFET Overcurrent Trip		$V_{CC} = 5V$		90		A
IMON-REFIN at OCP			<b>1.1</b>	1.2	<b>1.3</b>	V
<b>TEMPERATURE MONITOR</b>						
Over-Temperature Rising Threshold				140		$^\circ\text{C}$
Over-Temperature Falling Threshold				125		$^\circ\text{C}$
Over-Temperature Hysteresis				15		$^\circ\text{C}$
Temperature Coefficient				8		mV/K
TMON Voltage at $+25^\circ\text{C}$ Temperature		$V(T_J) = 0.6V + (8\text{mV} \cdot T_J)$		0.80		V
TMON High at Over-Temperature			<b>2.3</b>	2.5	<b>2.7</b>	V

**Electrical Specifications** Recommended operating conditions, unless otherwise noted. **Boldface limits apply across the operating temperature range,  $T_j = -40^\circ\text{C}$  to  $+125^\circ\text{C}$ .** (Continued)

PARAMETER	SYMBOL	TEST CONDITIONS	MIN (Note 6)	TYP	MAX (Note 6)	UNIT
<b>FAULT PIN</b>						
Output Low Voltage		5mA		0.18	0.26	V
Leakage Current				16		nA
<b>BOOTSTRAP DIODE</b>						
Forward Voltage Drop		5mA		0.09		V
ON-Resistance	$R_F$			16		$\Omega$
<b>LGCTRL PIN</b>						
Rising Threshold		Logic high; (Normal: obeys PWM)		1.29	1.60	V
Falling Threshold		Logic low; (Forces GL low; LFET off)	<b>0.70</b>	1.01		V
<b>MOSFETs</b>						
High-Side MOSFET (HFET) $r_{DS(ON)}$				3.84		m $\Omega$
Low-Side MOSFET (LFET) $r_{DS(ON)}$				0.76		m $\Omega$

NOTES:

- Compliance to datasheet limits is assured by one or more methods: production test, characterization, and/or design.
- These ratings vary with PCB layout and operating condition, and limited by SPS temperature and thermal shutdown trip point.

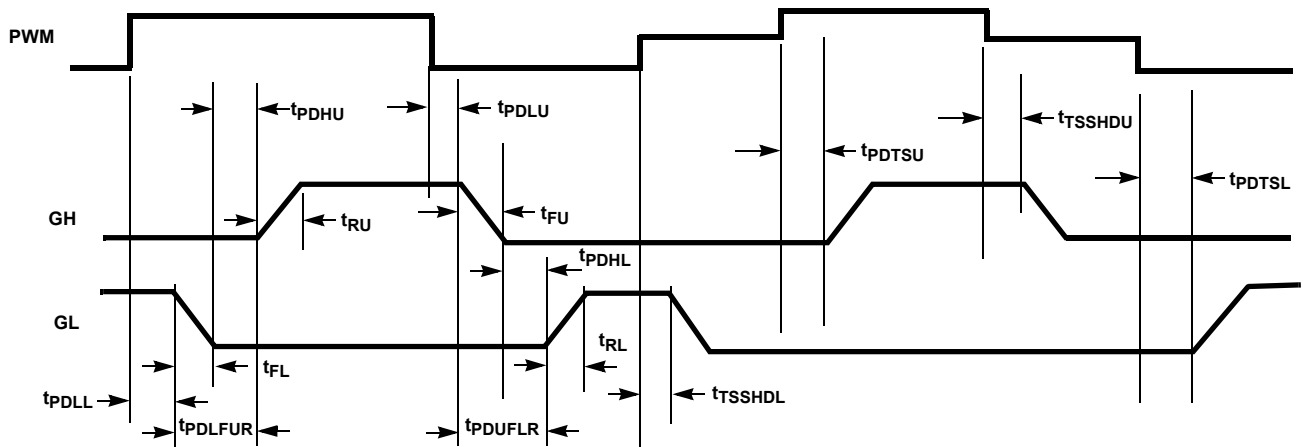

FIGURE 5. TIMING DIAGRAM (INTERNAL SIGNALS)

# Typical Performance Characteristics

PVCC = 5V, T<sub>A</sub> = +25 °C, unless otherwise stated.

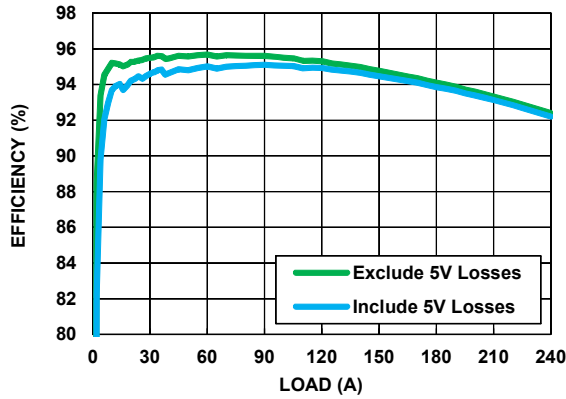

FIGURE 6. 1.8V V<sub>OUT</sub> POWER STAGE EFFICIENCY (V<sub>IN</sub> = 12V; f<sub>SW</sub> = 500kHz; L<sub>OUT</sub> = 0.18μH/0.17mΩ/FP1008-180-R; AUTO-PHASE ENABLED IN 6-PHASE OPERATION)

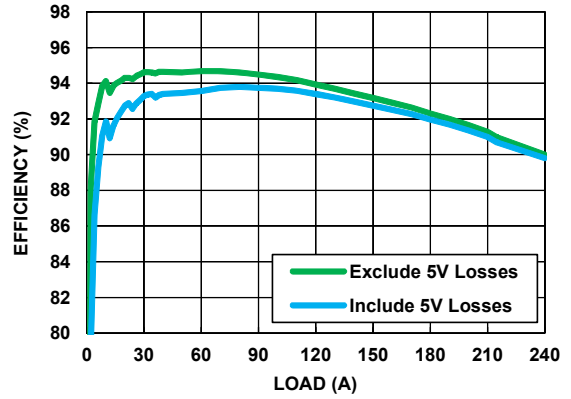

FIGURE 7. 1.2V V<sub>OUT</sub> POWER STAGE EFFICIENCY (V<sub>IN</sub> = 12V; f<sub>SW</sub> = 500kHz; L<sub>OUT</sub> = 0.18μH/0.17mΩ/FP1008-180-R; AUTO-PHASE ENABLED IN 6-PHASE OPERATION)

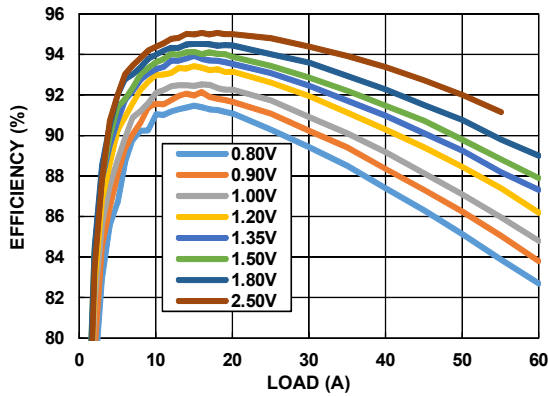

FIGURE 8. POWER STAGE EFFICIENCY (V<sub>IN</sub> = 12V; f<sub>SW</sub> = 500kHz; L<sub>OUT</sub> = 0.18μH/0.17mΩ/FP1008-180-R; INCLUDE INDUCTOR AND ISL99227, ISL99227B LOSSES)

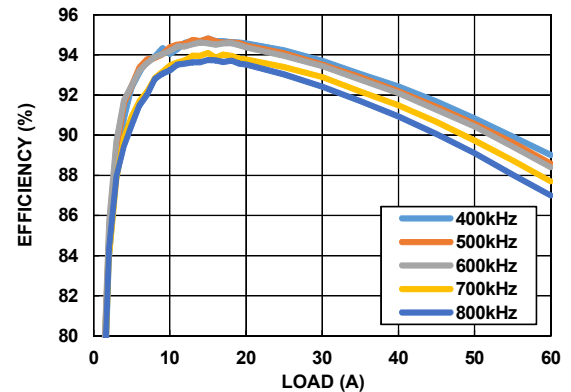

FIGURE 9. POWER STAGE EFFICIENCY (V<sub>IN</sub> = 12V; V<sub>OUT</sub> = 1.8V; L<sub>OUT</sub> = 0.18μH/0.17mΩ/FP1008-180-R; INCLUDE INDUCTOR AND ISL99227, ISL99227B LOSSES)

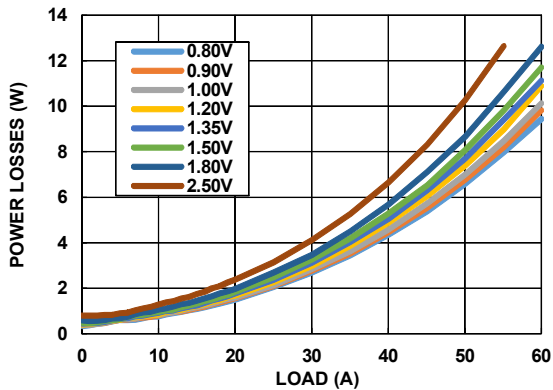

FIGURE 10. ISL99227, ISL99227B POWER DISSIPATION (V<sub>IN</sub> = 12V; f<sub>SW</sub> = 500kHz; L<sub>OUT</sub> = 0.18μH/0.17mΩ/FP1008-180-R)

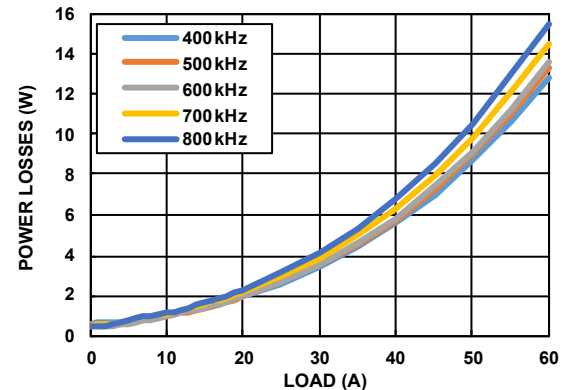

FIGURE 11. ISL99227, ISL99227B POWER DISSIPATION (V<sub>IN</sub> = 12V; V<sub>OUT</sub> = 1.8V; L<sub>OUT</sub> = 0.18μH/0.17mΩ/FP1008-180-R)

## Operation

The ISL99227 and ISL99227B are optimized drivers and power stage solutions for high density synchronous DC/DC power conversion. They include high performance GH and GL drivers, an NFET controlled to function as a bootstrap diode, and a MOSFET pair optimized for high switching frequency buck voltage regulators. They also include advanced power management features listed as follows:

- Accurate current and thermal reporting outputs.
- Fault protections of HFET overcurrent, HFET short, over-temperature, VCC UVLO and VIN UVLO.

### Power-On Reset (POR)

During initial start-up, the V<sub>CC</sub> voltage rise is monitored. If the rising V<sub>CC</sub> voltage exceeds 3.86V (typical) for 125μs, then normal operation of the driver is enabled. The PWM signals are passed through to the gate drivers, the TMON output is valid and the IMON-REFIN output starts at zero, and becomes valid on the first GL signal. If V<sub>CC</sub> drops below the falling threshold of 3.58V (typical), operation of the driver is disabled. The PVCC voltage is not monitored because it should be from the same supply as V<sub>CC</sub>.

V<sub>IN</sub> POR is also monitored. When both V<sub>CC</sub> and V<sub>IN</sub> reach above their POR trip points, it enables HFET overcurrent protection.

Both V<sub>CC</sub> and V<sub>IN</sub> POR are gated to the FAULT# pin, which goes high once both V<sub>CC</sub> and V<sub>IN</sub> are above their POR levels after 125μs and no other faults occur.

### Shoot-Through Protection

Before POR, the undervoltage protection function is activated and both GH and GL are held active low (HFET and LFET off). After POR (the Rising Thresholds; see “Electrical Specifications” on [page 8](#)) and a 125μs delay, the PWM and LGCTRL signals are used to control both high-side and low-side MOSFETs, as shown in [Table 2](#).

The ISL99227 and ISL99227B dead time control is optimized for high efficiency and guarantees that simultaneous conduction of both FETs cannot occur.

If the driver has no bias voltage applied (either V<sub>CC</sub> or PVCC missing) and is unable to actively hold the MOSFETs off, an integrated 20kΩ resistor from the upper MOSFET gate-to-source will aid in keeping the HFET device in its off state. This can be especially critical in applications where the input voltage rises before the ISL99227 and ISL99227B V<sub>CC</sub> and PVCC supplies.

TABLE 2. GH AND GL OPERATION TRUTH TABLE

PWM	LGCTRL	GH	GL	HFET, LFET	COMMENT
3-state	X	0	0	Both off	
0	1	0	1	LFET on	Normal
1	1	1	0	HFET on	Normal
0	0	0	0	LFET off	GL low
1	0	1	0	HFET on	Normal

### Tri-State PWM Input

The ISL99227 supports a 3.3V PWM tri-level input and is compatible with Renesas digital multiphase controllers as well as other control ICs using 3.3V PWM logic. Use the ISL99227B for 5V PWM logic, like ISL6617A doubler with 5V PWM logic output (see [Table 1 on page 5](#)). If the pin is pulled into and remains in the tri-state window for a set hold-off time, the driver will force both MOSFETs to their off states. When the PWM signal moves outside the shutdown window, the driver immediately resumes driving the MOSFETs according to the PWM commands.

This feature is used by Renesas' PWM controllers as a method of forcing both MOSFETs off. If the PWM input is left floating, the pin will be pulled into the tri-state window internally and thus force both MOSFETs to a safe off state.

Although the PWM input can sustain a voltage as high as V<sub>CC</sub>, the ISL99227 is not compatible with a controller (such as the ISL63xx family) that actively drives its mid-level in tri-state higher than 1.7V.

### Bootstrap Function

The ISL99227 and ISL99227B feature an internal NFET that is controlled to function as a bootstrap diode. A high quality ceramic capacitor should be placed in close proximity across the BOOT and PHASE pins. The bootstrap capacitor can range between 0.1μF~0.22μF (0402~0603 and X5R~X7R) for normal buck switching applications.

### Current Monitoring

LFET current is monitored and a signal proportional to that current is the output on the IMON pin (relative to the REFIN pin). The IMON and REFIN pins should be connected to the appropriate current sense input pin of the controller. This method does not require external R<sub>SENSE</sub> or DCR sensing of the inductor current.

[Figure 12](#) depicts the low-side current sense concept. After the falling edge of the PWM, there are two delays; one that represents the expected propagation delay from PWM to GH/SW and a second blanking delay to allow time for the transition to settle; typical total time is ~350ns. The IMON output approximates the actual I<sub>L</sub> waveform.

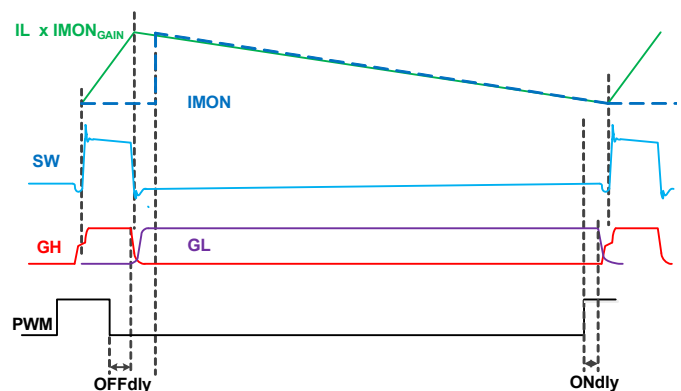

FIGURE 12. LFET CURRENT SAMPLE DIAGRAM

The HFET current is NOT monitored in the same way, so no valid measured current is available while PWM is high (including the short delays before and after). During this time, the IMON will output the last valid LFET current before the sampling stopped. On start-up after POR, the IMON will output zero (relative to REFIN, which represents zero current) until the switching begins and then the current can be properly measured.

The high-side FET current is separately monitored for OC conditions; see the following “Overcurrent Protection” section.

### Overcurrent Protection

Figure 13 shows the timing diagram of an overcurrent fault. There is a comparator monitoring the HFET current while it is on (GH high; also requires  $V_{IN}$  POR above its trip point). If the current is higher than 90A (typical; not user-programmable), then an OC fault is detected. The GH will be forced low, even if PWM is still high; this effectively shortens the PWM (and GH) pulse width, to limit the current. The IMON pin is pulled up to  $REFIN + 1.2V$ , which will be detected by the controller as an overcurrent fault. The controller is then expected to force PWM to tri-state (gates off both FETs), which signals the SPS that the fault has been acknowledged. The fault clears  $\sim 1\mu s$  after PWM enters tri-state. The IMON flag is released after the delay. The driver will then normally respond to the PWM inputs. If the PWM tri-state signal is not received after the fault, then the fault stays asserted and the IMON pin remains high.

Note that if the controller does NOT acknowledge, the IMON flag will stay high indefinitely, which will also hold GH low.

If OC is detected, the FAULT# pin is also pulled low; the timing on the FAULT# pin will follow that of the IMON pin.

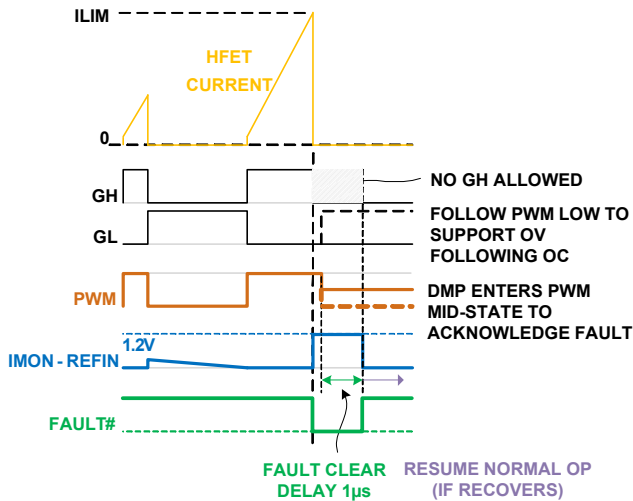

FIGURE 13. OVERCURRENT FAULT TIMING DIAGRAM

### Shorted HFET Protection

In case of a shorted HFET, the SW node will have excessive positive voltage present even when the LFET is turned on. The ISL99227 and ISL99227B monitor the SW node during periods when the LFET is on (GL is high) and should that voltage exceed 100mV (typical), the HFET short fault is declared. The ISL99227 and ISL99227B will pull the IMON pin high and the FAULT# will be pulled low. However, the fault will be latched; VCC POR is needed to reset it. GH will be gated low (ignore PWM = high), thus the ISL99227 and ISL99227B will still respond to PWM tri-state and logic low.

### Thermal Monitoring

The ISL99227 and ISL99227B monitor their internal temperature and provides a signal proportional to that temperature on the TMON pin. TMON has a voltage of 600mV at 0°C and reflects temperature at 8mV/°C. The TMON output is valid 125µs after VCC POR.

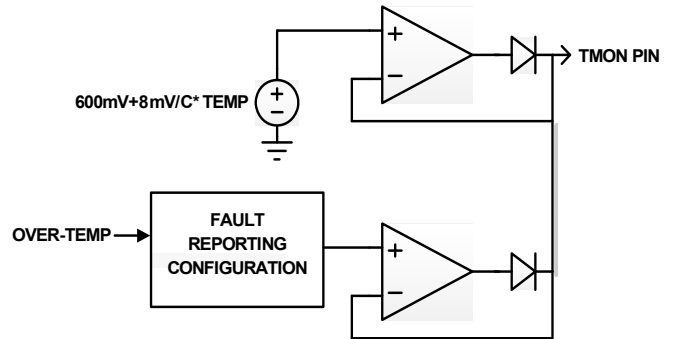

FIGURE 14. OVER-TEMPERATURE FAULT

Figure 14 shows a simplified functional representation. The top section includes the sensor and the output buffer. The bottom section includes the protection sensing that will pull the output high. The TMON pin is configured internally such that a user can tie multiple pins together externally and the resulting TMON bus will assume the voltage of the highest contributor (representing the highest temperature).

### Thermal Protection

If the internal temperature exceeds the over-temperature trip point (+140°C typical), the TMON pin will be pulled high (to  $\sim 2.5V$ ), and the FAULT# pin will be pulled low. No other action is taken on-chip. Both the TMON and FAULT# pins will remain in the fault mode until the junction temperature drops below +125°C (typical); at that point, the TMON and FAULT# pins resume normal operation.

## FAULT Reporting

Overcurrent and shorted HFET detections will pull the IMON pin to a high (fault) level, so that the PWM controller should quickly recognize it as out of the normal range. Over-temperature detection will pull the TMON pin to a high (fault) level, so that the PWM controller should quickly recognize it as out of the normal range.

All of the above faults, plus the VCC and VIN POR (UVLO) conditions, will also pull down the FAULT# pin. This can be used by the controller (or system) as a fault detection and can also be used to disable the controller through its Enable pin.

The fault reporting and respective SPS response are summarized in [Table 3](#).

**TABLE 3. FAULT REPORTING SUMMARY**

FAULT EVENT	IMON	TMON	FAULT#	RESPONSE
OC	HIGH	N/A	LOW	GH gated off. The controller should acknowledge and force its PWM to tri-state to keep both HFET and LFET off. The fault is cleared $\sim 1\mu\text{s}$ after PWM enters tri-state, otherwise, it stays asserted. (If system OVP occurs, the controller may send PWM low to turn on LFET).
Shorted HFET	IMON Latched HIGH	N/A	FAULT# Latched LOW	GH gated off, until fault latch is cleared by VCC POR. GL follows PWM.
OT	N/A	HIGH	LOW	GH and GL follow PWM.
VCC UVLO	IMON-REFIN = OV	TMON Not Valid	LOW	Switching stops while in UVLO. Once above VCC POR, after $125\mu\text{s}$ : GH and GL follow PWM; the FAULT# pin is released; TMON is valid; IMON-REFIN is valid after GL first goes low.
VIN UVLO	OC not valid	N/A	LOW	GH and GL follow PWM.

## PCB Layout Considerations

Proper PCB layout will reduce noise coupling to other circuits, improve thermal performance and maximize the efficiency. The following is meant to lead to an optimized layout:

- Place multiple  $10\mu\text{F}$  or greater ceramic capacitors directly on the device between VIN and GND as indicated in [Figure 15 on page 14](#). This is the most critical decoupling and will reduce parasitic inductance in the power switching loop. This will reduce overall electrical stress on the device as well as reduce coupling to other circuits. Best practice is to place the decoupling capacitors on the same PCB side as the device. For a design with tight space requirements, these decoupling capacitors can be placed under the device, that is, bottom layer, as shown in [Figure 17 on page 15](#).
- Connect GND to the system GND plane with a large via array as close to the GND pins as design rules allow. This improves thermal and electrical performance.
- Place PVCC, VCC, and BOOT-PHASE decoupling capacitors at the IC pins as shown in [Figure 15 on page 14](#).
- Note that the SW plane connecting the ISL99227 and ISL99227B and inductor must carry full load current and will create resistive loss if not sized properly. However, it is also a very noisy node that should not be oversized or routed close to any sensitive signals. Best practice is to place the inductor as close to the device as possible and thus minimize the required area for the SW connection. If one must choose a long route of either the VOUT side of the inductor or the SW side, choose the quiet VOUT side. Best practice is to locate ISL99227 and ISL99227B as close to the final load as possible and thus avoid noisy or lossy routes to the load.
- The IMON and IREF network and their vias should not sit on the top of the VIN plane. A keep out area is recommended, as shown in [Figure 17 on page 15](#).
- The PCB is a better thermal heatsink material than any top side cooling materials. The PCB always has enough vias to connect VIN and GND planes. Insufficient vias will yield lower efficiency and very poor thermal performance.

[Figures 16](#) and [17](#) show a multiphase PCB layout example for dual footprint, a device compatible with ISL99227. For a reference design file, contact Renesas Application [support](#).

**TABLE 4. AVAILABLE EVALUATION BOARDS**

EVALUATION BOARDS	PEAK EFFICIENCY (%)	SMBus/ PMBus/ $I^2C$	DESCRIPTION
ISL69127-61P-EV1Z	95.7% at 60A	Yes	6+1 Dual Output VR13 Evaluation Board for V <sub>CORE</sub> and V <sub>SA</sub> Applications
ISL69125-31P-EV2Z	94.5% at 30A	Yes	3+1 Dual Outputs DDR4 Evaluation Board for VR13 Memory Applications

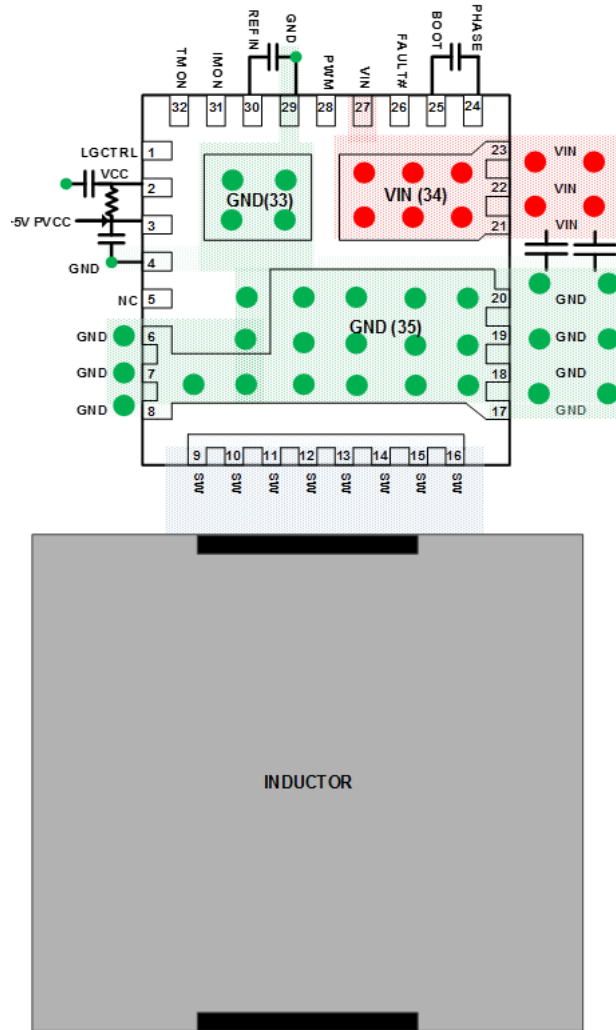

**FIGURE 15. SINGLE-PHASE PCB LAYOUT FOR MINIMIZING CURRENT LOOPS**

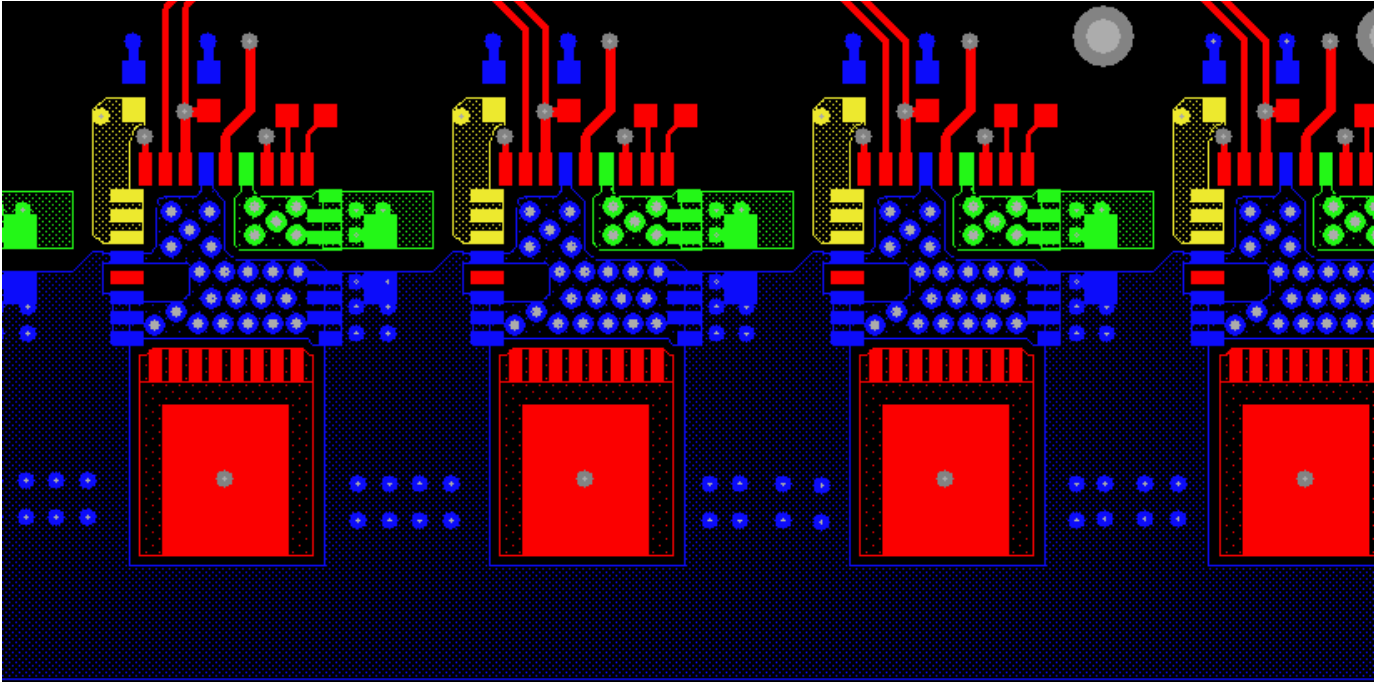

FIGURE 16. MULTIPHASE PCB LAYOUT EXAMPLE TOP LAYER FOR DUAL FOOTPRINT, A DEVICE COMPATIBLE WITH ISL99227

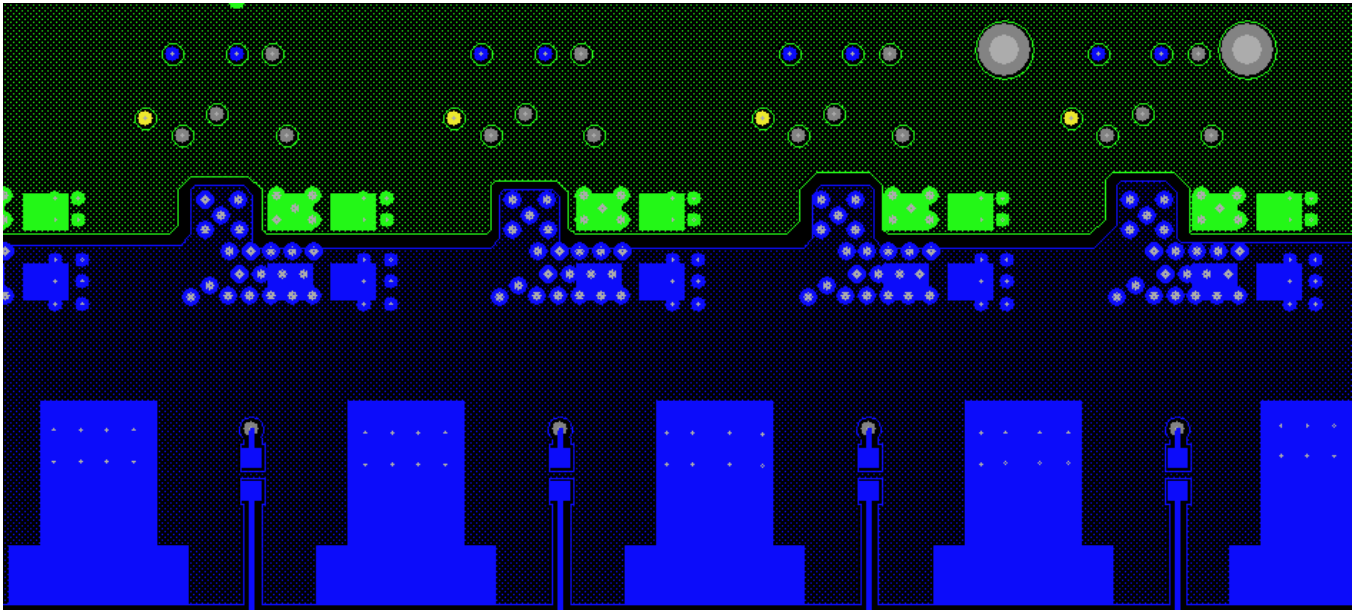

FIGURE 17. MULTIPHASE PCB LAYOUT EXAMPLE BOTTOM LAYER

**Revision History** The revision history provided is for informational purposes only and is believed to be accurate, but not warranted. Please go to the web to make sure that you have the latest revision.

DATE	REVISION	CHANGE
Nov 22, 2023	3.01	Removed About Intersil section. Updated Note 2 in the ordering information table.
Oct 2, 2017	3.00	Updated Related Literature section. Updated IMON pin description (last sentence). Updated Figure 2. Updated Figure 3. Added "Pad" to 33, 34, and 35 in the pin descriptions numbering. Updated About Intersil verbiage. Updated POD to the latest revision. Changes are as follows: -Added dimensions to Bottom View (0.20, 0.20, 1.15, 0.95)
Oct 27, 2016	2.00	Updated Ordering Information table on page 5 to show all Released parts. Added "for dual footprint, a device compatible with ISL99227" on page 13. Updated Figures 16 and 17 for dual footprint on page 15.
Sept 28, 2016	1.00	Updated POD to revision 2 which added additional dimensions to the typical recommended land pattern and bottom views, and eliminated Note 6 which repeated the sentiments in the first line of Note 5.
Aug 30, 2016	0.00	Initial Release

# Package Outline Drawing

For the most recent package outline drawing, see [L32.5x5V](#).

## L32.5x5V

32 LEAD DOUBLE COOLING QUAD FLAT NO-LEAD PLASTIC PACKAGE  
Rev 3 9/17

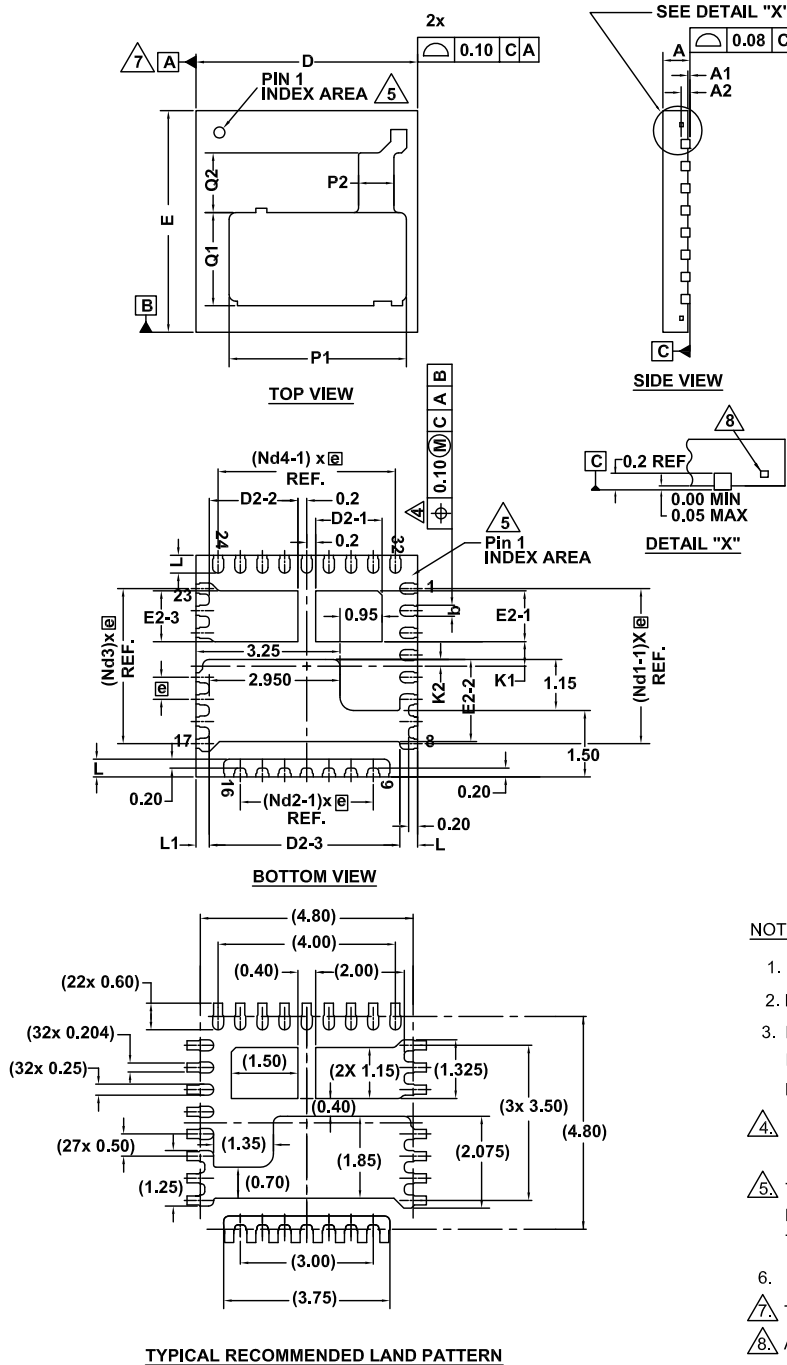

SYMBOL	MILLIMETERS		
	MIN	NOM	MAX
A (Note 7)	0.56	0.61	0.66
A1	0.00	-	0.05
A2	0.20 REF.		
b (Note 4)	0.20	0.25	0.30
D	5.00 BSC		
D2-1	1.45	1.50	1.55
D2-2	1.95	2.00	2.05
D2-3	4.25	4.30	4.35
e	0.50 BSC		
E	5.00 BSC		
E2-1	1.10	1.15	1.20
E2-2	1.80	1.85	1.90
E2-3	1.10	1.15	1.20
K1	0.55 BSC		
K2	0.15 BSC		
L	0.35	0.40	0.45
L1	0.25	0.30	0.35
P1	3.95	4.00	4.05
P2	0.75	-	1.15
Q1	2.05	2.10	2.15
Q2	1.30	1.35	1.40
N (Note 3)	32		
Nd1 (Note 3)	8 (PIN1~PIN8)		
Nd2 (Note 3)	8 (PIN9~PIN15)		
Nd3 (Note 3)	7 (PIN16~PIN22)		
Nd4 (Note 3)	9 (PIN23~PIN31)		

- NOTE:**
1. Use millimeters as the primary measurement.
  2. Dimensioning & tolerances conform to ASME Y14.5M. - 1994.
  3. N is the number of terminals.  
Nd1 and Nd3 is the number of terminals in Y-direction &  
Nd2 and Nd4 is the number of terminals in X-direction.
  4. Dimension b applies to plated terminal and is measured between 0.20 and 0.25mm from terminal tip.
  5. The configuration of the pin #1 identifier is optional, but must be located within the zone indicated. The pin #1 identifier may be either a mold or mark feature.
  6. Package warpage MAX 0.08mm.
  7. Tiebar shown (if present) is a non-functional feature.
  8. Applied only for terminals.

## IMPORTANT NOTICE AND DISCLAIMER

RENESAS ELECTRONICS CORPORATION AND ITS SUBSIDIARIES (“RENESAS”) PROVIDES TECHNICAL SPECIFICATIONS AND RELIABILITY DATA (INCLUDING DATASHEETS), DESIGN RESOURCES (INCLUDING REFERENCE DESIGNS), APPLICATION OR OTHER DESIGN ADVICE, WEB TOOLS, SAFETY INFORMATION, AND OTHER RESOURCES “AS IS” AND WITH ALL FAULTS, AND DISCLAIMS ALL WARRANTIES, EXPRESS OR IMPLIED, INCLUDING, WITHOUT LIMITATION, ANY IMPLIED WARRANTIES OF MERCHANTABILITY, FITNESS FOR A PARTICULAR PURPOSE, OR NON-INFRINGEMENT OF THIRD PARTY INTELLECTUAL PROPERTY RIGHTS.

These resources are intended for developers skilled in the art designing with Renesas products. You are solely responsible for (1) selecting the appropriate products for your application, (2) designing, validating, and testing your application, and (3) ensuring your application meets applicable standards, and any other safety, security, or other requirements. These resources are subject to change without notice. Renesas grants you permission to use these resources only for development of an application that uses Renesas products. Other reproduction or use of these resources is strictly prohibited. No license is granted to any other Renesas intellectual property or to any third party intellectual property. Renesas disclaims responsibility for, and you will fully indemnify Renesas and its representatives against, any claims, damages, costs, losses, or liabilities arising out of your use of these resources. Renesas' products are provided only subject to Renesas' Terms and Conditions of Sale or other applicable terms agreed to in writing. No use of any Renesas resources expands or otherwise alters any applicable warranties or warranty disclaimers for these products.

(Disclaimer Rev.1.0 Mar 2020)

### Corporate Headquarters

TOYOSU FORESIA, 3-2-24 Toyosu,  
Koto-ku, Tokyo 135-0061, Japan  
[www.renesas.com](http://www.renesas.com)

### Contact Information

For further information on a product, technology, the most up-to-date version of a document, or your nearest sales office, please visit:  
[www.renesas.com/contact/](http://www.renesas.com/contact/)

### Trademarks

Renesas and the Renesas logo are trademarks of Renesas Electronics Corporation. All trademarks and registered trademarks are the property of their respective owners.

## Looking for pricing, stock, or lifecycle information?

Click below to explore more details on WIN SOURCE:

- ⊖ [View ISL99227IRZ on WIN SOURCE](#)
- ⊖ [Renesas Electronics America](#) Information

## Optimize Your Supply Chain with WIN SOURCE Solutions

- ✓ Global Sourcing Solution
- ✓ Obsolete Management
- ✓ Cost Control Management
- ✓ Shortage Management
- ✓ Alternative Solution
- ✓ Excess Inventory Management