



THE DATASHEET OF ISL6207CR



ISL6207

High Voltage Synchronous Rectified Buck MOSFET Driver

FN9075
 Rev 8.00
 December 2, 2005

The ISL6207 is a high frequency, dual MOSFET driver, optimized to drive two N-Channel power MOSFETs in a synchronous-rectified buck converter topology in mobile computing applications. This driver, combined with an Intersil Multi-Phase Buck PWM controller, such as ISL6223, ISL6215, and ISL6216, forms a complete single-stage core-voltage regulator solution for advanced mobile microprocessors.

The ISL6207 features 4A typical sink current for the lower gate driver. The 4A typical sink current is capable of holding the lower MOSFET gate during the Phase node rising edge to prevent the shoot-through power loss caused by the high dv/dt of the Phase node. The operation voltage matches the 30V breakdown voltage of the MOSFETs commonly used in mobile computer power supplies.

The ISL6207 also features a three-state PWM input that, working together with most of Intersil multiphase PWM controllers, will prevent a negative transient on the output voltage when the output is being shut down. This feature eliminates the Schottky diode, that is usually seen in a microprocessor power system for protecting the microprocessor, from reversed-output-voltage damage.

The ISL6207 has the capacity to efficiently switch power MOSFETs at frequencies up to 2MHz. Each driver is capable of driving a 3000pF load with a 15ns propagation delay and less than a 10ns transition time. This product implements bootstrapping on the upper gate with an internal bootstrap Schottky diode, reducing implementation cost, complexity, and allowing the use of higher performance, cost effective N-Channel MOSFETs. Adaptive shoot-through protection is integrated to prevent both MOSFETs from conducting simultaneously.

Features

- Drives Two N-Channel MOSFETs
- Adaptive Shoot-Through Protection
- 30V Operation Voltage
- 0.4Ω On-Resistance and 4A Sink Current Capability
- Supports High Switching Frequency
 - Fast Output Rise Time
 - Short Propagation Delays
- Three-State PWM Input for Power Stage Shutdown
- Internal Bootstrap Schottky Diode
- QFN Package:
 - Compliant to JEDEC PUB95 MO-220 QFN - Quad Flat No Leads - Package Outline
 - Near Chip Scale Package footprint, which improves PCB efficiency and has a thinner profile
- Pb-Free Plus Anneal Available (RoHS Compliant)

Applications

- Core Voltage Supplies for Intel and AMD® Mobile Microprocessors
- High Frequency Low Profile DC/DC Converters
- High Current Low Output Voltage DC/DC Converters
- High Input Voltage DC/DC Converters

Related Literature

- Technical Brief TB363 “Guidelines for Handling and Processing Moisture Sensitive Surface Mount Devices (SMDs)”
- Technical Brief TB389 “PCB Land Pattern Design and Surface Mount Guidelines for QFN Packages”

Pinouts

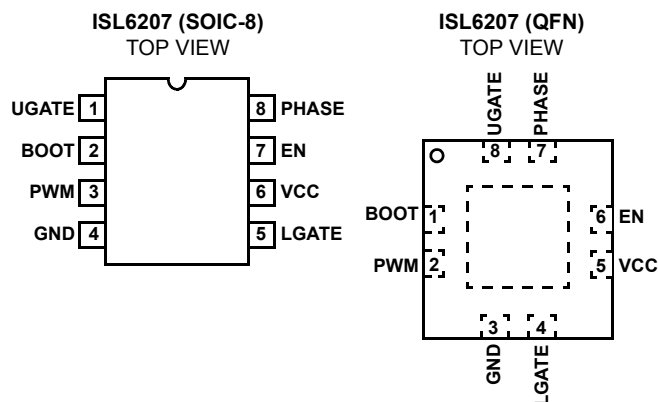

Ordering Information

PART NUMBER	PART MARKING	TEMP. RANGE (°C)	PACKAGE	PKG. DWG. #
ISL6207CB	ISL6207CB	-10 to 85	8 Lead SOIC	M8.15
ISL6207CBZ (Note)	ISL6207CBZ	-10 to 85	8 Lead SOIC (Pb-free)	M8.15
ISL6207CBZA (Note)	ISL6207CBZ	-10 to 85	8 Lead SOIC (Pb-free)	M8.15
ISL6207CR	207C	-10 to 85	8 Lead 3x3 QFN	L8.3x3
ISL6207CRZ (Note)	07CZ	-10 to 85	8 Lead 3x3 QFN (Pb-free)	L8.3x3
ISL6207CRZA (Note)	07CZ	-10 to 85	8 Lead 3x3 QFN (Pb-free)	L8.3x3
ISL6207HBZ (Note)	ISL6207HBZ	-10 to 100	8 Ld SOIC (Pb-free)	M8.15
ISL6207HRZ (Note)	07HZ	-10 to 100	8 Ld 3x3 QFN (Pb-free)	L8.3x3

Add "-T" suffix for tape and reel.

NOTE: Intersil Pb-free plus anneal products employ special Pb-free material sets; molding compounds/die attach materials and 100% matte tin plate termination finish, which are RoHS compliant and compatible with both SnPb and Pb-free soldering operations. Intersil Pb-free products are MSL classified at Pb-free peak reflow temperatures that meet or exceed the Pb-free requirements of IPC/JEDEC J STD-020.

ISL6207 Block Diagram

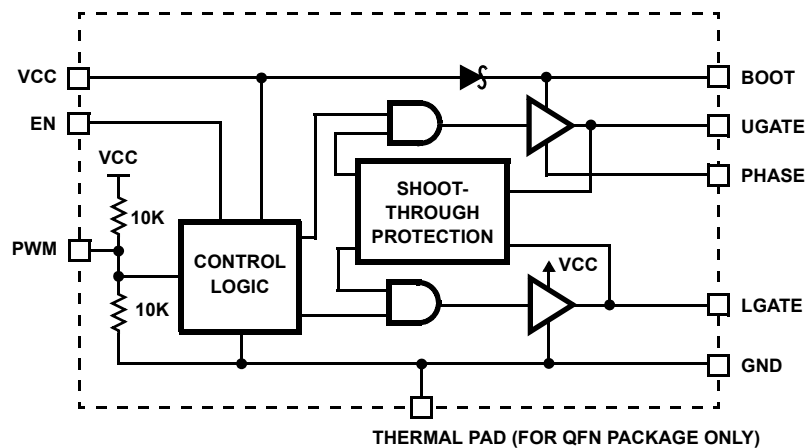

Typical Application - Two Phase Converter Using ISL6207 Gate Drivers

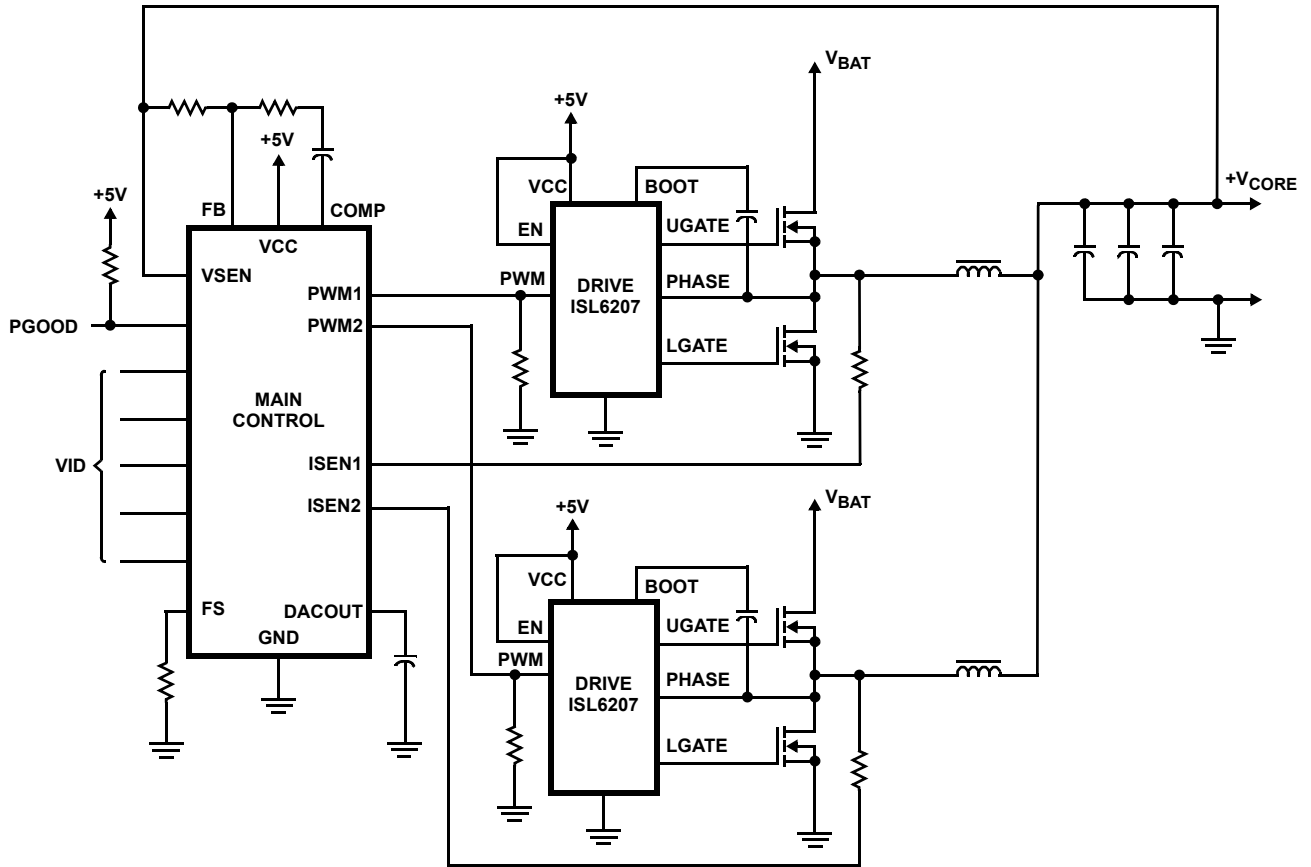

Absolute Maximum Ratings

Supply Voltage (V_{CC})	-0.3V to 7V
Input Voltage (V_{EN}, V_{PWM})	-0.3V to $V_{CC} + 0.3V$
BOOT Voltage (V_{BOOT})	-0.3V to 36V
BOOT to PHASE Voltage ($V_{BOOT-PHASE}$)	-0.3V to 7V
PHASE Voltage	GND - 0.3V (DC) to $V_{BOOT} + 0.3V$
	GND - 5V (<100ns Pulse Width, 10 μ J) to $V_{BOOT} + 0.3V$
UGATE Voltage	$V_{PHASE} - 0.3V$ (DC) to $V_{BOOT} + 0.3V$
	$V_{PHASE} - 4V$ (<200ns Pulse Width, 20 μ J) to $V_{BOOT} + 0.3V$
LGATE Voltage	GND - 0.3V (DC) to $V_{VCC} + 0.3V$
	GND - 2V (<100ns Pulse Width, 4 μ J) to $V_{VCC} + 0.3V$
Ambient Temperature Range	-40°C to 125°C

Recommended Operating Conditions

Ambient Temperature Range	-10°C to 100°C
Maximum Operating Junction Temperature	125°C
Supply Voltage, V_{CC}	5V \pm 10%

CAUTION: Stresses above those listed in "Absolute Maximum Ratings" may cause permanent damage to the device. This is a stress only rating and operation of the device at these or any other conditions above those indicated in the operational sections of this specification is not implied.

NOTES:

- The Phase Voltage is capable of withstanding -7V when the BOOT pin is at GND.
- θ_{JA} is measured with the component mounted on a high effective thermal conductivity test board in free air. See Tech Brief TB379 for details.
- θ_{JA} is measured in free air with the component mounted on a high effective thermal conductivity test board with "direct attach" features. See Tech Brief TB379.
- For θ_{JC} , the "case temp" location is the center of the exposed metal pad on the package underside.

Electrical Specifications Recommended Operating Conditions, Unless Otherwise Noted.

PARAMETER	SYMBOL	TEST CONDITIONS	MIN	TYP	MAX	UNITS
VCC SUPPLY CURRENT						
Bias Supply Current	I_{VCC}	EN = LOW	-	-	5.0	μ A
Bias Supply Current	I_{VCC}	PWM pin floating, $V_{VCC} = 5V$	-	30	-	μ A
BOOTSTRAP DIODE						
Forward Voltage	V_F	$V_{VCC} = 5V$, forward bias current = 2mA	0.45	0.60	0.65	V
PWM INPUT						
Input Current	I_{PWM}	$V_{PWM} = 5V$	-	250	-	μ A
		$V_{PWM} = 0V$	-	-250	-	μ A
PWM Three-State Rising Threshold		$V_{VCC} = 5V$	-	-	1.7	V
PWM Three-State Falling Threshold		$V_{VCC} = 5V$	3.3	-	-	V
Three-State Shutdown Holdoff Time		$V_{VCC} = 5V$, temperature = 25°C	-	300	-	ns
EN INPUT						
EN LOW Threshold			1.0	-	-	V
EN HIGH Threshold			-	-	2.0	V
SWITCHING TIME						
UGATE Rise Time (Note 5)	t_{RUGATE}	$V_{VCC} = 5V$, 3nF Load	-	8	-	ns
LGATE Rise Time (Note 5)	t_{RLGATE}	$V_{VCC} = 5V$, 3nF Load	-	8	-	ns
UGATE Fall Time (Note 5)	t_{FUGATE}	$V_{VCC} = 5V$, 3nF Load	-	8	-	ns
LGATE Fall Time (Note 5)	t_{FLGATE}	$V_{VCC} = 5V$, 3nF Load	-	4	-	ns
UGATE Turn-Off Propagation Delay	$t_{PDLUGATE}$	$V_{VCC} = 5V$, Outputs Unloaded	-	18	-	ns
LGATE Turn-Off Propagation Delay	$t_{PDLLGATE}$	$V_{VCC} = 5V$, Outputs Unloaded	-	15	-	ns

Thermal Information

Thermal Resistance (Typical)	θ_{JA} (°C/W)	θ_{JC} (°C/W)
SOIC Package (Note 2)	110	N/A
QFN Package (Notes 3, 4)	95	36
Maximum Junction Temperature (Plastic Package)	150°C	
Maximum Storage Temperature Range	-65°C to 150°C	
Maximum Lead Temperature (Soldering 10s)	300°C (SOIC - Lead Tips Only)	

Electrical Specifications Recommended Operating Conditions, Unless Otherwise Noted. (Continued)

PARAMETER	SYMBOL	TEST CONDITIONS	MIN	TYP	MAX	UNITS
UGATE Turn-On Propagation Delay	$t_{PDHUGATE}$	$V_{VCC} = 5V$, Outputs Unloaded	10	20	30	ns
LGATE Turn-On Propagation Delay	$t_{PDHLGATE}$	$V_{VCC} = 5V$, Outputs Unloaded	10	20	30	ns
OUTPUT						
Upper Drive Source Resistance	R_{UGATE}	500mA Source Current	-	1.0	2.5	Ω
		-10°C to 85°C	-	1.0	2.2	Ω
Upper Driver Source Current (Note 5)	I_{UGATE}	$V_{UGATE-PHASE} = 2.5V$	-	2.0	-	A
Upper Drive Sink Resistance	R_{UGATE}	500mA Sink Current	-	1.0	2.5	Ω
		-10°C to 85°C	-	1.0	2.2	Ω
Upper Driver Sink Current (Note 5)	I_{UGATE}	$V_{UGATE-PHASE} = 2.5V$	-	2.0	-	A
Lower Drive Source Resistance	R_{LGATE}	500mA Source Current	-	1.0	2.5	Ω
		-10°C to 85°C	-	1.0	2.2	Ω
Lower Driver Source Current (Note 5)	I_{LGATE}	$V_{LGATE} = 2.5V$	-	2.0	-	A
Lower Drive Sink Resistance	R_{LGATE}	500mA Sink Current	-	0.4	1.0	Ω
		-10°C to 85°C	-	0.4	0.8	Ω
Lower Driver Sink Current (Note 5)	I_{LGATE}	$V_{LGATE} = 2.5V$	-	4.0	-	A

NOTE:

- Guaranteed by characterization, not 100% tested in production.

Functional Pin Description**UGATE (Pin 1 for SOIC-8, Pin 8 for QFN)**

The UGATE pin is the upper gate drive output. Connect to the gate of high-side power N-Channel MOSFET.

BOOT (Pin 2 for SOIC-8, Pin 1 for QFN)

BOOT is the floating bootstrap supply pin for the upper gate drive. Connect the bootstrap capacitor between this pin and the PHASE pin. The bootstrap capacitor provides the charge to turn on the upper MOSFET. See the Bootstrap Diode and Capacitor section under DESCRIPTION for guidance in choosing the appropriate capacitor value.

PWM (Pin 3 for SOIC-8, Pin 2 for QFN)

The PWM signal is the control input for the driver. The PWM signal can enter three distinct states during operation, see the three-state PWM Input section under DESCRIPTION for further details. Connect this pin to the PWM output of the controller. In addition, place a 500k Ω resistor to ground from this pin. This allows for proper three-state operation under all start-up conditions.

GND (Pin 4 for SOIC-8, Pin 3 for QFN)

GND is the ground pin. All signals are referenced to this node.

LGATE (Pin 5 for SOIC-8, Pin 4 for QFN)

LGATE is the lower gate drive output. Connect to gate of the low-side power N-Channel MOSFET.

VCC (Pin 6 for SOIC-8, Pin 5 for QFN)

Connect the VCC pin to a +5V bias supply. Place a high quality bypass capacitor from this pin to GND.

EN (Pin 7 for SOIC-8, Pin 6 for QFN)

EN is the enable input pin. Connect this pin to HIGH to enable, and LOW to disable, the IC. When disabled, the IC draws less than 1 μ A bias current.

PHASE (Pin 8 for SOIC-8, Pin 7 for QFN)

Connect the PHASE pin to the source of the upper MOSFET and the drain of the lower MOSFET. This pin provides a return path for the upper gate driver.

Description**Operation**

Designed for speed, the ISL6207 dual MOSFET driver controls both high-side and low-side N-Channel FETs from one externally provided PWM signal.

A rising edge on PWM initiates the turn-off of the lower MOSFET (see Timing Diagram). After a short propagation delay [$t_{PDLLGATE}$], the lower gate begins to fall. Typical fall times [t_{FLGATE}] are provided in the Electrical Specifications section. Adaptive shoot-through circuitry monitors the LGATE voltage and determines the upper gate delay time [$t_{PDHUGATE}$], based on how quickly the LGATE voltage drops below 1V. This prevents both the lower and upper MOSFETs from conducting simultaneously, or shoot-through. Once this delay period is completed, the upper gate drive begins to rise [t_{RUGATE}], and the upper MOSFET turns on.

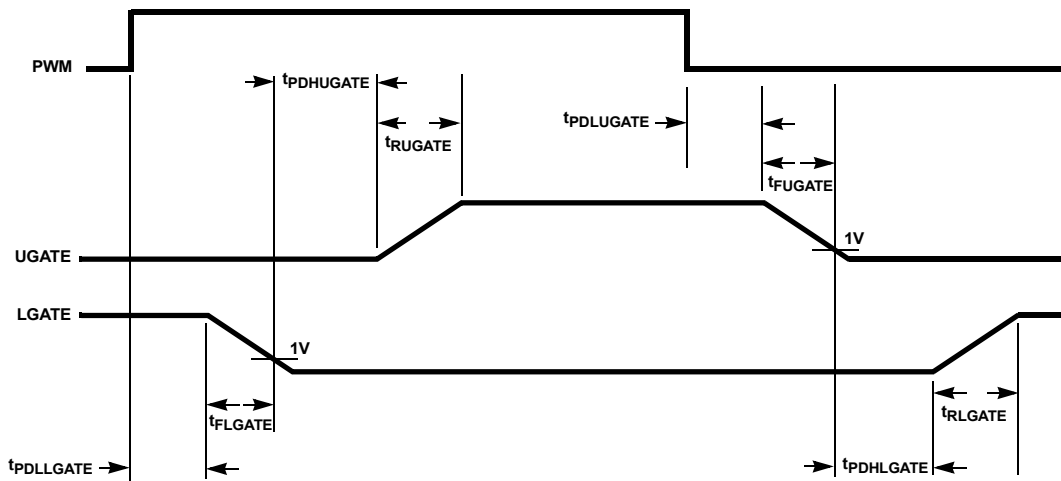

FIGURE 1. TIMING DIAGRAM

A falling transition on PWM indicates the turn-off of the upper MOSFET and the turn-on of the lower MOSFET. A short propagation delay [$t_{PDHUGATE}$] is encountered before the upper gate begins to fall [t_{FUGATE}]. Again, the adaptive shoot-through circuitry determines the lower gate delay time $t_{PDHLGATE}$. The upper MOSFET gate-to-source voltage is monitored, and the lower gate is allowed to rise, after the upper MOSFET gate-to-source voltage drops below 1V. The lower gate then rises [t_{RLGATE}], turning on the lower MOSFET.

This driver is optimized for converters with large step down ratio, such as those used in a mobile-computer core voltage regulator. The lower MOSFET is usually sized much larger.

This driver is optimized for converters with large step down compared to the upper MOSFET because the lower MOSFET conducts for a much longer time in a switching period. The lower gate driver is therefore sized much larger to meet this application requirement. The 0.4 Ω on-resistance and 4A sink current capability enable the lower gate driver to absorb the current injected to the lower gate through the drain-to-gate capacitor of the lower MOSFET and prevent a shoot-through caused by the high dv/dt of the phase node.

Three-State PWM Input

A unique feature of the ISL6207 and other Intersil drivers is the addition of a shutdown window to the PWM input. If the PWM signal enters and remains within the shutdown window for a set holdoff time, the output drivers are disabled and both MOSFET gates are pulled and held low. The shutdown state is removed when the PWM signal moves outside the shutdown window. Otherwise, the PWM rising and falling thresholds outlined in the ELECTRICAL SPECIFICATIONS determine when the lower and upper gates are enabled. During start-up, PWM should be in the three-state position ($1/2 V_{CC}$). However, with rising V_{CC} , the active tracking elements for PWM are not active until $V_{CC} > 1.2V$, which

leaves PWM in a high impedance (undetermined) state; therefore, a 500k Ω resistor must be placed from the PWM pin to GND.

Adaptive Shoot-Through Protection

Both drivers incorporate adaptive shoot-through protection to prevent upper and lower MOSFETs from conducting simultaneously and shorting the input supply. This is accomplished by ensuring the falling gate has turned off one MOSFET before the other is allowed to turn on.

During turn-off of the lower MOSFET, the LGATE voltage is monitored until it reaches a 1V threshold, at which time the UGATE is released to rise. Adaptive shoot-through circuitry monitors the upper MOSFET gate-to-source voltage during UGATE turn-off. Once the upper MOSFET gate-to-source voltage has dropped below a threshold of 1V, the LGATE is allowed to rise.

Internal Bootstrap Diode

This driver features an internal bootstrap Schottky diode. Simply adding an external capacitor across the BOOT and PHASE pins completes the bootstrap circuit.

The bootstrap capacitor must have a maximum voltage rating above the maximum battery voltage plus 5V. The bootstrap capacitor can be chosen from the following equation:

$$C_{BOOT} \geq \frac{Q_{GATE}}{\Delta V_{BOOT}}$$

where Q_{GATE} is the amount of gate charge required to fully charge the gate of the upper MOSFET. The ΔV_{BOOT} term is defined as the allowable droop in the rail of the upper drive.

As an example, suppose an upper MOSFET has a gate charge, Q_{GATE} , of 25nC at 5V and also assume the droop in the drive voltage over a PWM cycle is 200mV. One will find that a bootstrap capacitance of at least 0.125 μ F is required.

The next larger standard value capacitance is 0.22 μ F. A good quality ceramic capacitor is recommended.

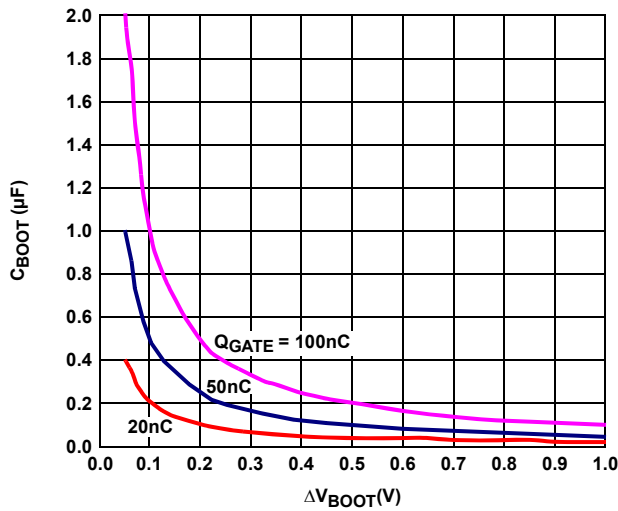

FIGURE 2. BOOTSTRAP CAPACITANCE vs BOOT RIPPLE VOLTAGE

Power Dissipation

Package power dissipation is mainly a function of the switching frequency and total gate charge of the selected MOSFETs. Calculating the power dissipation in the driver for a desired application is critical to ensuring safe operation. Exceeding the maximum allowable power dissipation level will push the IC beyond the maximum recommended operating junction temperature of 125°C. The maximum allowable IC power dissipation for the SO-8 package is approximately 800mW. When designing the driver into an application, it is recommended that the following calculation be performed to ensure safe operation at the desired frequency for the selected MOSFETs. The power dissipated by the driver is approximated as:

$$P = f_{sw}(1.5V_U Q_U + V_L Q_L) + I_{DDQ} V_{CC}$$

where f_{sw} is the switching frequency of the PWM signal. V_U and V_L represent the upper and lower gate rail voltage. Q_U and Q_L is the upper and lower gate charge determined by MOSFET selection and any external capacitance added to the gate pins. The $I_{DDQ} V_{CC}$ product is the quiescent power of the driver and is typically negligible.

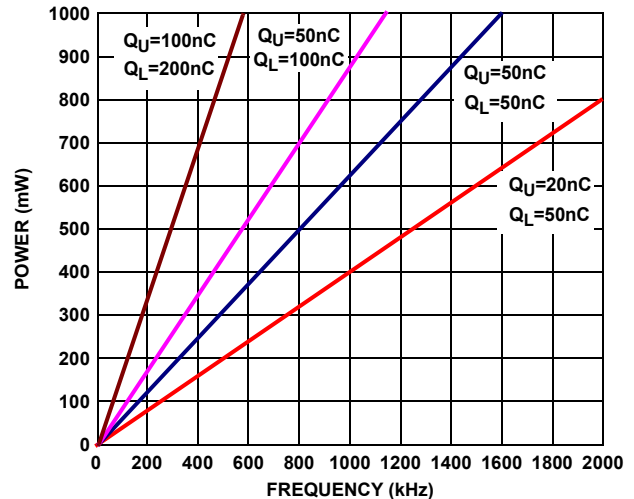

FIGURE 3. POWER DISSIPATION vs FREQUENCY

Layout Considerations

Reducing Phase Ring

The parasitic inductances of the PCB and power devices (both upper and lower FETs) could cause increased PHASE ringing, which may lead to voltages that exceed the absolute maximum rating of the devices. When PHASE rings below ground, the negative voltage could add charge to the bootstrap capacitor through the internal bootstrap diode. Under worst-case conditions, the added charge could overstress the BOOT and/or PHASE pins. To prevent this from happening, the user should perform a careful layout inspection to reduce trace inductances, and select low lead inductance MOSFETs and drivers. D²PAK and DPAK packaged MOSFETs have high parasitic lead inductances, as opposed to SOIC-8. If higher inductance MOSFETs must be used, a Schottky diode is recommended across the lower MOSFET to clamp negative PHASE ring.

A good layout would help reduce the ringing on the phase and gate nodes significantly:

- Avoid using vias for decoupling components where possible, especially in the BOOT-to-PHASE path. Little or no use of vias for VCC and GND is also recommended. Decoupling loops should be short.
- All power traces (UGATE, PHASE, LGATE, GND, VCC) should be short and wide, and avoid using vias. If vias must be used, two or more vias per layer transition is recommended.
- Keep the SOURCE of the upper FET as close as thermally possible to the DRAIN of the lower FET.
- Keep the connection in between the SOURCE of lower FET and power ground wide and short.
- Input capacitors should be placed as close to the DRAIN of the upper FET and the SOURCE of the lower FET as thermally possible.

Note: Refer to Intersil Tech Brief TB447 for more information.

Thermal Management

For maximum thermal performance in high current, high switching frequency applications, connecting the thermal pad of the QFN part to the power ground with multiple vias, or placing a low noise copper plane underneath the SOIC part is recommended. This heat spreading allows the part to achieve its full thermal potential.

Suppressing MOSFET Gate Leakage

With VCC at ground potential, UGATE and LGATE are high impedance. In this state, any stray leakage has the potential to deliver charge to either gate. If UGATE receives sufficient charge to bias the device on (Note: Internal circuitry prevents leakage currents from charging above 1.8V), a low impedance path will be connected between the MOSFET drain and PHASE. If the input power supply is present and active, the system could see potentially damaging currents. Worst-case leakage currents are on the order of pico-amps; therefore, a 10k Ω resistor, connected from UGATE to PHASE, is more than sufficient to bleed off any stray leakage current. This resistor will not affect the normal performance of the driver or reduce its efficiency.

**Quad Flat No-Lead Plastic Package (QFN)
Micro Lead Frame Plastic Package (MLFP)**

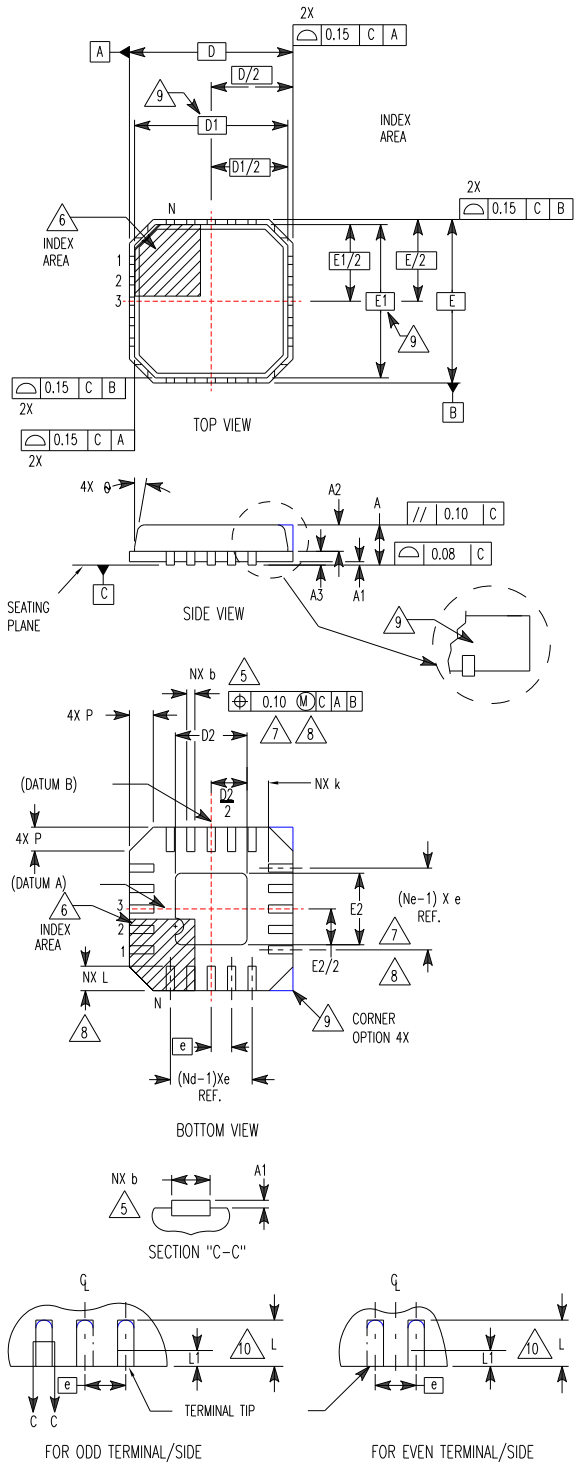

L8.3x3

**8 LEAD QUAD FLAT NO-LEAD PLASTIC PACKAGE
(COMPLIANT TO JEDEC MO-220VEEC ISSUE C)**

SYMBOL	MILLIMETERS			NOTES
	MIN	NOMINAL	MAX	
A	0.80	0.90	1.00	-
A1	-	-	0.05	-
A2	-	-	1.00	9
A3	0.20 REF			9
b	0.23	0.28	0.38	5, 8
D	3.00 BSC			-
D1	2.75 BSC			9
D2	0.25	1.10	1.25	7, 8
E	3.00 BSC			-
E1	2.75 BSC			9
E2	0.25	1.10	1.25	7, 8
e	0.65 BSC			-
k	0.25		-	-
L	0.35	0.60	0.75	8
L1	-	-	0.15	10
N	8			2
Nd	2			3
Ne	2			3
P	-	-	0.60	9
θ	-	-	12	9

Rev. 1 10/02

NOTES:

Intersil Lead Free products employ special lead free material sets; molding compounds / die attach materials and 100% matte tin plate termination finish, which is compatible with both SnPb and lead free soldering operations. Intersil Lead Free products are MSL classified at lead free peak reflow temperatures that meet or exceed the lead free requirements of IPC/JEDEC J Std-020B.

1. Dimensioning and tolerancing conform to ASME Y14.5-1994.
2. N is the number of terminals.
3. Nd and Ne refer to the number of terminals on each D and E.
4. All dimensions are in millimeters. Angles are in degrees.
5. Dimension b applies to the metallized terminal and is measured between 0.15mm and 0.30mm from the terminal tip.
6. The configuration of the pin #1 identifier is optional, but must be located within the zone indicated. The pin #1 identifier may be either a mold or mark feature.
7. Dimensions D2 and E2 are for the exposed pads which provide improved electrical and thermal performance.
8. Nominal dimensions are provided to assist with PCB Land Pattern Design efforts, see Intersil Technical Brief TB389.
9. Features and dimensions A2, A3, D1, E1, P & θ are present when Anvil singulation method is used and not present for saw singulation.
10. Depending on the method of lead termination at the edge of the package, a maximum 0.15mm pull back (L1) maybe present. L minus L1 to be equal to or greater than 0.3mm.

Looking for pricing, stock, or lifecycle information?

Click below to explore more details on WIN SOURCE:

-  [View ISL6207CR on WIN SOURCE](#)
-  [Renesas Electronics America](#) Information

Optimize Your Supply Chain with WIN SOURCE Solutions

-  Global Sourcing Solution
-  Obsolete Management
-  Cost Control Management
-  Shortage Management
-  Alternative Solution
-  Excess Inventory Management