



**THE DATASHEET OF  
ISL24211IRTZ**



ISL24211

Programmable  $V_{COM}$  Calibrator with EEPROM and Output Buffer

FN7585  
Rev 0.00  
February 23, 2011

The ISL24211 is an 8-bit programmable current sink that can be used in conjunction with an external voltage divider to generate a voltage source ( $V_{COM}$ ) positioned between the analog supply voltage and ground. The current sink's full-scale range is controlled by an external resistor,  $R_{SET}$ . With the appropriate choice of external resistors  $R_1$  and  $R_2$ , the  $V_{COM}$  voltage range can be controlled between any arbitrary voltage range. The ISL24211 has an 8-bit data register and 8-bit EEPROM for storing both a volatile and a permanent value for its output, with an I<sup>2</sup>C interface to read and write to the register and EEPROM. After the part is programmed, the I<sup>2</sup>C interface is no longer needed; on power-up the EEPROM contents are automatically transferred to the data register, and the pre-programmed output voltage appears on the  $V_{COM\_OUT}$  pin.

The ISL24211 also features an integrated, wide-bandwidth, high output drive buffer amplifier that can directly drive the  $V_{COM}$  input of an LCD panel.

The ISL24211 is available in an 10 Ld 3mm x 3mm TDFN package. This package has a maximum height of 0.8mm for very low profile designs. The ambient operating temperature range is -40°C to +85°C.

**Features**

- 8-bit, 256-Step, Adjustable Sink Current Output
- 60MHz  $V_{COM}$  Buffer/Amplifier
- 4.5V to 19.0V Analog Supply Range for Normal Operation (10.8V Minimum Analog Supply Voltage for Programming)
- 2.25V to 3.6V Logic Supply Voltage Operating Range
- 400kHz, I<sup>2</sup>C Interface
- On-Chip 8-Bit EEPROM
- Guaranteed Monotonic Over-Temperature
- Compatible with applications using the 7-bit ISL45041
- Pb-free (RoHS-compliant)
- Ultra-Thin 10 Ld TDFN (3 x 3 x 0.8mm max)

**Applications**

- LCD Panel  $V_{COM}$  Generator
- Electrophoretic Display  $V_{COM}$  Generator

**Related Literature**

- AN1627 "ISL24211IRTZ-EVALZ Evaluation Board User Guide"

**Typical Application**

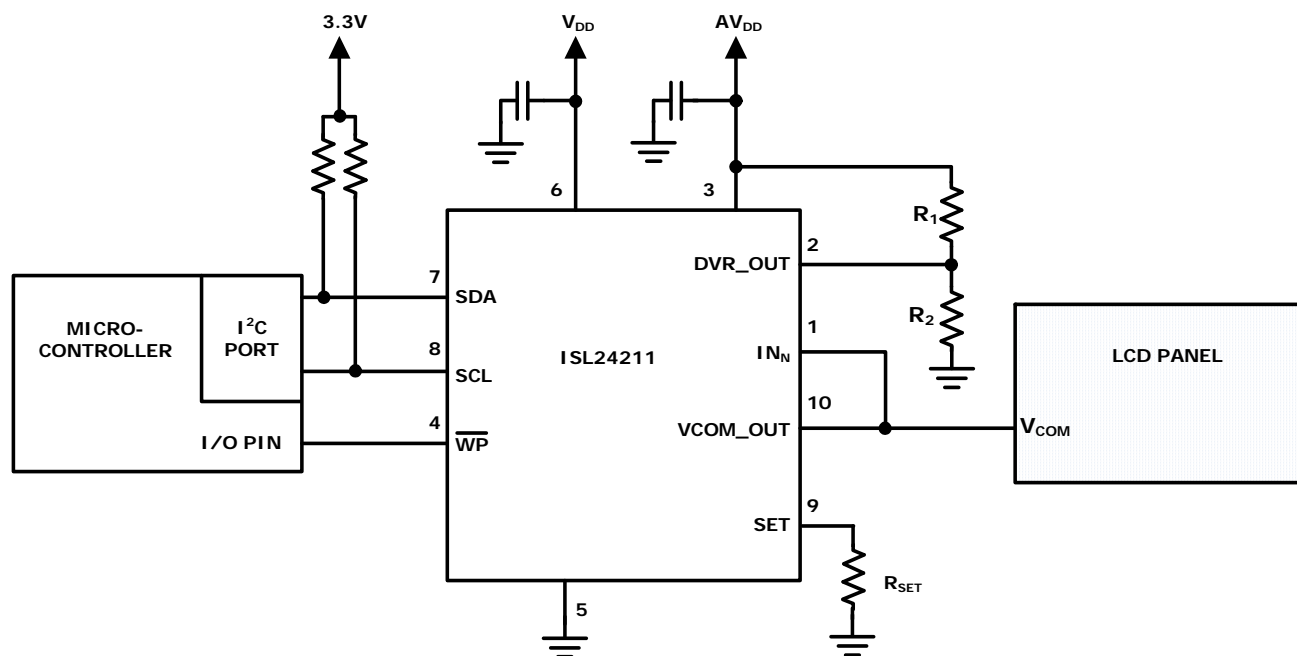

FIGURE 1. TYPICAL ISL24211 APPLICATION

# Block Diagram

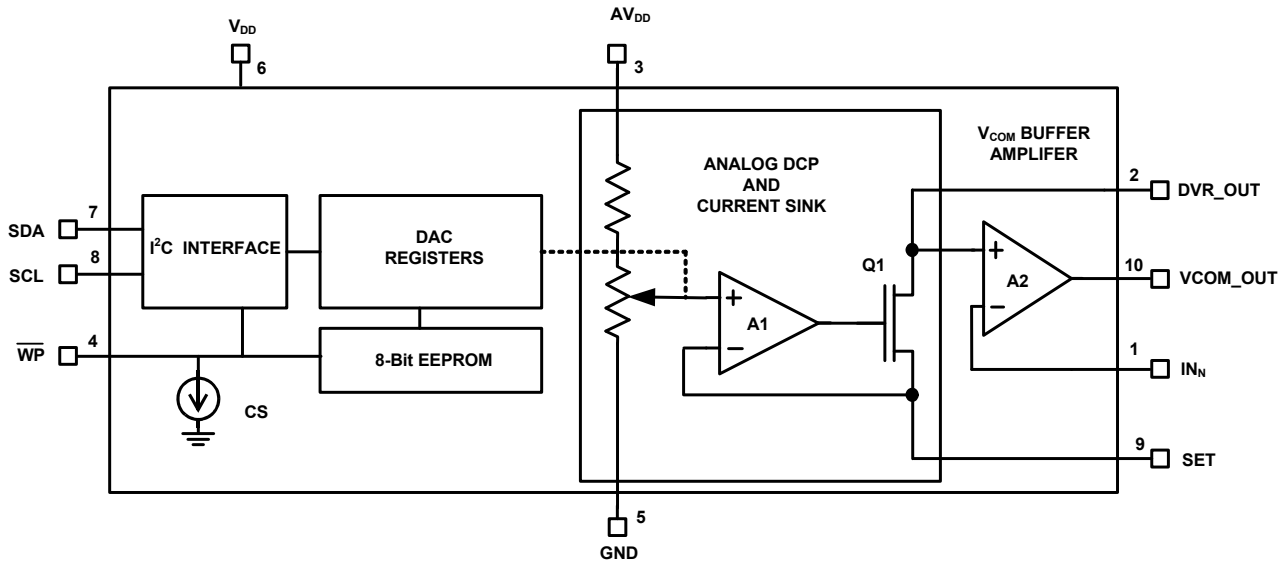
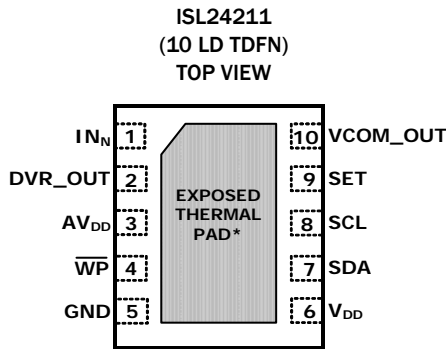

FIGURE 2. BLOCK DIAGRAM OF THE ISL24211

## Pin Configuration



## Pin Descriptions

PIN NAME	PIN NUMBER	FUNCTION
IN <sub>N</sub>	1	Negative (inverting) input of the V <sub>COM</sub> buffer op amp. This pin is used to provide feedback from the end point of the V <sub>COM</sub> trace.
DVR_OUT	2	Adjustable Sink Current Output Pin. The current sunk into the DVR_OUT pin is equal to the DAC setting times the maximum adjustable sink current divided by 256. See the "SET" pin function description below (pin 9) for the maximum adjustable sink current setting. Also tied to the non-inverting input of buffer amp.
AV <sub>DD</sub>	3	Analog Power Supply Input. Bypass to GND with 0.1μF capacitor.
WP	4	EEPROM Write Protect. Active Low. 0 = Programming disabled; 1 = Programming allowed.
GND	5	Ground connection.
V <sub>DD</sub>	6	Digital power supply input. Bypass to GND with 0.1μF capacitor.
SDA	7	I <sup>2</sup> C Serial Data Input
SCL	8	I <sup>2</sup> C Clock Input
SET	9	Maximum Sink Current Adjustment Point. Connect a resistor from SET to GND to set the maximum adjustable sink current of the DVR_OUT pin. The maximum adjustable sink current is equal to (AV <sub>DD</sub> /20) divided by R <sub>SET</sub> .
VCOM_OUT	10	Output of the buffer amplifier
PAD	-	Thermal pad should be connected to system ground plane to optimize thermal performance.

---

## Ordering Information

PART NUMBER (Notes 1, 2, 3)	PART MARKING	INTERFACE	TEMP RANGE (°C)	PACKAGE (Pb-Free)	PKG. DWG. #
ISL24211IRTZ	211Z	I <sup>2</sup> C	-40 to +85	10 Ld 3x3 TDFN	L10.3x3A
ISL24211IRTZ-EVALZ	Evaluation Board				

**NOTES:**

1. Add "-T\*" suffix for tape and reel. Please refer to [TB347](#) for details on reel specifications.
2. These Intersil Pb-free plastic packaged products employ special Pb-free material sets, molding compounds/die attach materials, and 100% matte tin plate plus anneal (e3 termination finish, which is RoHS compliant and compatible with both SnPb and Pb-free soldering operations). Intersil Pb-free products are MSL classified at Pb-free peak reflow temperatures that meet or exceed the Pb-free requirements of IPC/JEDEC J STD-020.
3. For Moisture Sensitivity Level (MSL), please see device information page [ISL24211](#). For more information on MSL please see techbrief [TB363](#).

## Absolute Maximum Ratings

Supply Voltage	
AV <sub>DD</sub> to GND	20V
V <sub>DD</sub> to GND	4V
Input Voltage with respect to Ground	
SET, IN <sub>N</sub>	4V
SCL, SDA and $\overline{WP}$	V <sub>DD</sub> + 0.3V
Output Voltage with respect to Ground	
DVR_OUT, VCOM_OUT	AV <sub>DD</sub>
Continuous Output Current	
DVR_OUT	5mA
VCOM_OUT	±100mA
ESD Ratings	
Human Body Model (Tested per JESD22-A114)	7kV
Machine Model (Tested per JESD22-A115)	300V
Charged Device Model (Tested per JESD22-C101)	2kV
Latch Up (Tested per JESD 78, Class II, Level A)	100mA

## Thermal Information

Thermal Resistance (Typical)	$\theta_{JA}$ (°C/W)	$\theta_{JC}$ (°C/W)
10 Ld TDFN Package (Notes 4, 5)	53	11
Moisture Sensitivity (see Technical Brief <a href="#">TB363</a> )		
All Packages	Level 1	
Maximum Die Temperature	+150°C	
Storage Temperature	-65°C to +150°C	
Pb-free Reflow Profile	see link below	
	<a href="http://www.intersil.com/pbfree/Pb-FreeReflow.asp">http://www.intersil.com/pbfree/Pb-FreeReflow.asp</a>	

## Recommended Operating Conditions

Operating Range	
AV <sub>DD</sub>	4.5V to 19V
V <sub>DD</sub>	2.25V to 3.6V
Ambient Operating Temperature	-40°C to +85°C

**CAUTION:** Do not operate at or near the maximum ratings listed for extended periods of time. Exposure to such conditions may adversely impact product reliability and result in failures not covered by warranty.

### NOTES:

- $\theta_{JA}$  is measured in free air with the component mounted on a high effective thermal conductivity test board with "direct attach" features. See Tech Brief TB379.
- For  $\theta_{JC}$ , the "case temp" location is the center of the exposed metal pad on the package underside.

**Electrical Specifications** Test Conditions: V<sub>DD</sub> = 3.3V, AV<sub>DD</sub> = 18V, R<sub>SET</sub> = 5k $\Omega$ , R<sub>1</sub> = 10k $\Omega$ , R<sub>2</sub> = 10k $\Omega$ , (See Figure 5), V<sub>COM\_OUT</sub> pin connected to IN<sub>N</sub>, unless otherwise specified. Typicals are at T<sub>A</sub> = +25°C. **Boldface limits apply over the operating temperature range, -40°C to +85°C.**

SYMBOL	PARAMETER	TEST CONDITIONS	MIN (Note 6)	TYP	MAX (Note 6)	UNITS
<b>DC CHARACTERISTICS</b>						
V <sub>DD</sub>	V <sub>DD</sub> Supply Range - Operating		<b>2.25</b>		<b>3.6</b>	V
AV <sub>DD</sub>	AV <sub>DD</sub> Supply Range Supporting EEPROM Programming		<b>10.8</b>		<b>19</b>	V
AV <sub>DD</sub>	AV <sub>DD</sub> Supply Range for Wide-Supply Operation (not supporting EEPROM Programming)		<b>4.5</b>		<b>19</b>	V
I <sub>DD</sub>	V <sub>DD</sub> Supply Current	$\overline{WP} = SCL = SDA = V_{DD}$		95	<b>300</b>	$\mu$ A
I <sub>AVDD</sub>	AV <sub>DD</sub> Supply Current	$\overline{WP} = SCL = SDA = V_{DD}$		3.8	<b>6.5</b>	mA
<b>DVR_OUT CHARACTERISTICS</b>						
ZSE <sub>SET</sub>	SET Zero-Scale Error				<b>±3</b>	LSB
FSE <sub>SET</sub>	SET Full-Scale Error				<b>±8</b>	LSB
TCV <sub>SET</sub>	SET Voltage Drift			7		$\mu$ V/°C
V <sub>DVR_OUT</sub>	DVR_OUT Voltage Range	I <sub>DVR_OUT</sub> < 0.5mA	<b>V<sub>SET</sub> + 0.4</b>		<b>AV<sub>DD</sub></b>	V
I <sub>DVR_OUT</sub>	Maximum DVR_OUT Sink Current			4		mA
INL	Integral Non-Linearity				<b>±2</b>	LSB
DNL	Differential Non-Linearity				<b>±1</b>	LSB
<b>OUTPUT AMPLIFIER CHARACTERISTICS</b>						
V <sub>OS</sub>	Input Offset Voltage			±2	<b>±15</b>	mV
TCV <sub>OS</sub>	Input Offset Voltage Drift			-6.3		$\mu$ V/°C
I <sub>B</sub>	Input Bias Current			0.001	<b>±1</b>	$\mu$ A
CMRR	Common-Mode Rejection Ratio		<b>55</b>	75		dB
PSRR	Power Supply Rejection Ratio		<b>60</b>	82		dB
A <sub>VOL</sub>	Open Loop Gain		<b>55</b>	75		dB
V <sub>OL</sub>	Output Swing Low	I <sub>L</sub> = -5mA		50	<b>150</b>	mV

**Electrical Specifications** Test Conditions:  $V_{DD} = 3.3V$ ,  $AV_{DD} = 18V$ ,  $R_{SET} = 5k\Omega$ ,  $R_1 = 10k\Omega$ ,  $R_2 = 10k\Omega$ , (See Figure 5),  $V_{COM\_OUT}$  pin connected to  $IN_N$ , unless otherwise specified. Typical values are at  $T_A = +25^\circ C$ . **Boldface limits apply over the operating temperature range,  $-40^\circ C$  to  $+85^\circ C$ .** (Continued)

SYMBOL	PARAMETER	TEST CONDITIONS	MIN (Note 6)	TYP	MAX (Note 6)	UNITS
$V_{OH}$	Output Swing High	$I_L = 5mA$	<b>17.85</b>	17.9		V
$I_{SC}$	Short Circuit Current (Sinking)		<b>300</b>	430		mA
	Short Circuit Current (Sourcing)		<b>450</b>	555		mA
SR	Slew Rate (Rising)	1k $\Omega$    8pF Load	<b>70</b>	116		V/ $\mu s$
	Slew Rate (Falling)	1k $\Omega$    8pF Load	<b>50</b>	93		V/ $\mu s$
$t_s$	Settling Time to 0.2%			150		ns
BW	-3dB Bandwidth			60		MHz
<b>I<sup>2</sup>C INPUTS AND OUTPUT</b>						
$V_{IH\_I2C}$	SDA, SCL Logic 1 Input Voltage		<b>1.44</b>			V
$V_{IL\_I2C}$	SDA, SCL Logic 0 Input Voltage				<b>0.55</b>	V
$V_{HYS\_I2C}$	SDA, SCL Hysteresis			260		mV
$I_{L\_I2C}$	SDA, SCL Input Leakage Current				$\pm 1$	$\mu A$
$V_{OL\_I2C}$	SDA Output Logic Low	$I = -3mA$			<b>0.4</b>	V
$V_{IH\_WP}$	$\overline{WP}$ Input Logic High		<b>0.7V<sub>DD</sub></b>			V
$V_{IL\_WP}$	$\overline{WP}$ Input Logic Low				<b>0.3V<sub>DD</sub></b>	V
$V_{HYS\_WP}$	$\overline{WP}$ Input Hysteresis			260		mV
$I_{L\_WP}$	$\overline{WP}$ Input Leakage Current		<b>-0.20</b>	-0.5	<b>-1</b>	$\mu A$
<b>I<sup>2</sup>C TIMING</b>						
$f_{CLK}$	I <sup>2</sup> C Clock Frequency				<b>400</b>	kHz
$t_{SCH}$	I <sup>2</sup> C Clock High Time		<b>0.6</b>			$\mu s$
$t_{SCL}$	I <sup>2</sup> C Clock Low Time		<b>1.3</b>			$\mu s$
$t_{DSP}$	I <sup>2</sup> C Spike Rejection Filter Pulse Width		<b>0</b>		<b>50</b>	ns
$t_{SDS}$	I <sup>2</sup> C Data Set Up Time		<b>250</b>			ns
$t_{SDH}$	I <sup>2</sup> C Data Hold Time		<b>250</b>			ns
$t_{BUF}$	I <sup>2</sup> C Time Between Stop and Start		<b>200</b>			$\mu s$
$t_{STS}$	I <sup>2</sup> C Repeated Start Condition Set-up		<b>0.6</b>			$\mu s$
$t_{STH}$	I <sup>2</sup> C Repeated Start Condition Hold		<b>0.6</b>			$\mu s$
$t_{SPS}$	I <sup>2</sup> C Stop Condition Set-up		<b>0.6</b>			$\mu s$
$C_{SDA}$	SDA Pin Capacitance				<b>10</b>	pF
$C_{SCL}$	SCL Pin Capacitance				<b>10</b>	pF
$t_{WR}$	EEPROM Write Cycle Time				<b>100</b>	ms

## NOTE:

6. Compliance to datasheet limits is assured by one or more methods: production test, characterization and/or design.

## Application Information

LCD panels have a  $V_{COM}$  (common voltage) that must be precisely set to minimize flicker. Figure 3 shows a typical  $V_{COM}$  adjustment circuit using a mechanical potentiometer, and the equivalent circuit replacement using the ISL24211. Having a digital  $I^2C$  interface enables automatic, digital flicker minimization during production test and alignment. After programming, the  $I^2C$  interface has no further use therefore, the ISL24211 automatically powers up with the correct  $V_{COM}$  voltage programmed previously.

The ISL24211 uses a digitally controllable potentiometer (DCP), with 256 steps of resolution (see Figure 4) to change the current drawn at the DVR\_OUT pin, which then changes the voltage created by the  $R_1$  to  $R_2$  resistor divider (see Figure 5). The DVR\_OUT voltage is then buffered by A2 to generate a buffered output voltage at the  $V_{COM\_OUT}$  pin, capable of directly driving the  $V_{COM}$  input of an LCD panel. The amount of current sunk is controlled by the setting of the DCP, which is recalled at power-up from the ISL24211's internal EEPROM. The EEPROM is typically programmed during panel manufacture. As noted in the Electrical Specifications on page 4, the ISL24211 requires a minimum  $AV_{DD}$  voltage of 10.8V for EEPROM programming, but will work in normal operation (with no EEPROM programming) down to 4.5V.

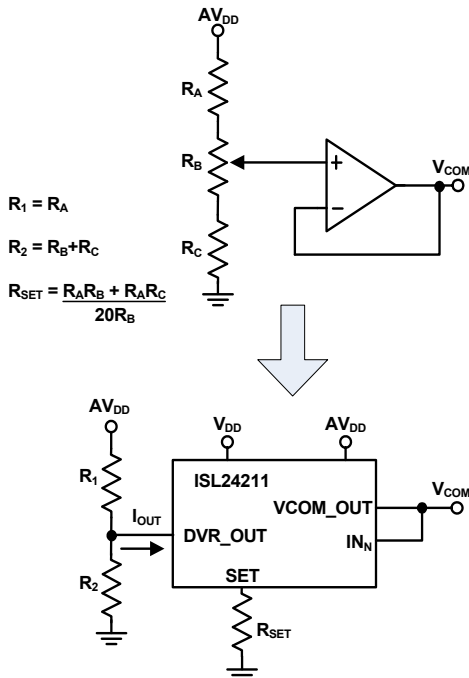

FIGURE 3. MECHANICAL ADJUSTMENT REPLACEMENT

### DCP (Digitally Controllable Potentiometer)

The DCP controls the voltage that ultimately controls the SET current. Figure 4 shows the relationship between the register value and the DCP's tap position. Note that a register value of 0 selects the first step of the resistor string. The output voltage of the DCP is given in Equation 1:

$$V_{DCP} = \left( \frac{\text{RegisterValue} + 1}{256} \right) \left( \frac{AV_{DD}}{20} \right) \quad (\text{EQ. 1})$$

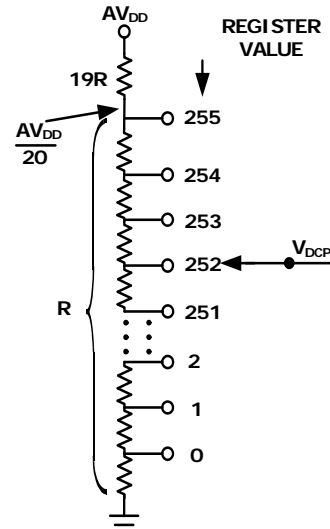

FIGURE 4. SIMPLIFIED SCHEMATIC OF DCP

### Output Current Sink

Figure 5 shows the schematic of the DVR\_OUT current sink. The combination of amplifier A1, transistor Q1, and resistor  $R_{SET}$  forms a voltage-controlled current source, with the voltage determined by the DCP setting.

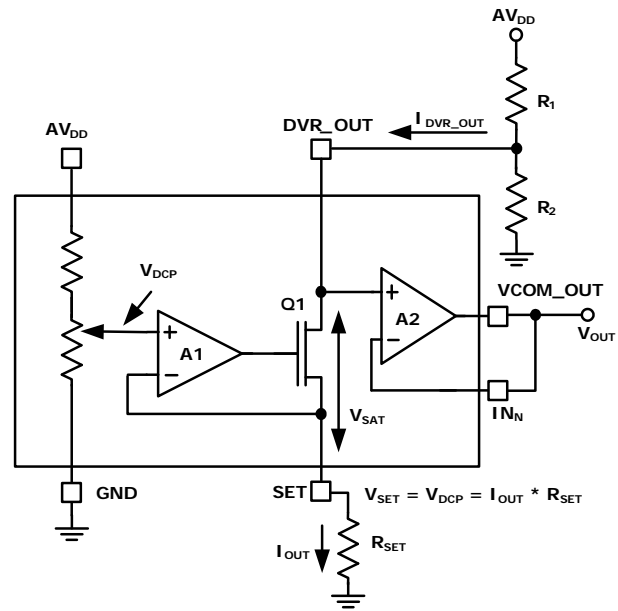

FIGURE 5. CURRENT SINK CIRCUIT

The external  $R_{SET}$  resistor sets the full-scale (maximum) sink current that can be pulled from the DVR\_OUT node. The relationship between  $I_{DVR\_OUT}$  and Register Value is shown in Equation 2.

$$I_{DVR\_OUT} = \frac{V_{DCP}}{R_{SET}} = \left( \frac{\text{RegisterValue} + 1}{256} \right) \left( \frac{AV_{DD}}{20} \right) \left( \frac{1}{R_{SET}} \right) \quad (\text{EQ. 2})$$

The maximum value of  $I_{DVR\_OUT}$  can be calculated by substituting the maximum register value of 255 into Equation 2, resulting in Equation 3:

$$I_{DVR\_OUT(MAX)} = \frac{AV_{DD}}{20R_{SET}} \quad (\text{EQ. 3})$$

Equation 2 can also be used to calculate the unit sink current step size per Register Code, resulting in Equation 4:

$$I_{STEP} = \frac{AV_{DD}}{(256)(20)(R_{SET})} \quad (\text{EQ. 4})$$

## Determination of $R_{SET}$

The ultimate goal for the ISL24211 is to generate an adjustable voltage between two endpoints,  $V_{COM\_MIN}$  and  $V_{COM\_MAX}$ , with a fixed power supply voltage,  $AV_{DD}$ . This is accomplished by choosing the correct values for  $R_{SET}$ ,  $R_1$  and  $R_2$ . The exact value of  $R_{SET}$  is not critical. Values from 1k to more than 100k will work under most conditions. The following expression calculates the minimum  $R_{SET}$  value:

$$R_{SET(MIN)} = \left( \frac{\frac{AV_{DD}}{16}}{\left( V_{OUT(MIN)} - \frac{AV_{DD}}{20} \right)} \right) (\text{k}\Omega) \quad (\text{EQ. 5})$$

Note that this is the absolute minimum value for  $R_{SET}$ . Larger  $R_{SET}$  values reduce quiescent power, since  $R_1$  and  $R_2$  are proportional to  $R_{SET}$ . The ISL24211 is tested with a 5k $\Omega$   $R_{SET}$ .

## Determination of $R_1$ and $R_2$

With  $AV_{DD}$ ,  $V_{COM(MIN)}$  and  $V_{COM(MAX)}$  known and  $R_{SET}$  chosen per the above requirements,  $R_1$  and  $R_2$  can be determined using Equations 6 and 7:

$$R_1 = 5120 \cdot R_{SET} \left( \frac{V_{COM(MAX)} - V_{COM(MIN)}}{256 \cdot V_{COM(MAX)} - V_{COM(MIN)}} \right) \quad (\text{EQ. 6})$$

$$R_2 = 5120 \cdot R_{SET} \left( \frac{V_{COM(MAX)} - V_{COM(MIN)}}{255 \cdot AV_{DD} + V_{COM(MIN)} - 256 \cdot V_{COM(MAX)}} \right) \quad (\text{EQ. 7})$$

## Final Transfer Function

The voltage at  $DVR\_OUT$  can be calculated from Equation 8:

$$V_{DVR\_OUT} = AV_{DD} \left( \frac{R_2}{R_1 + R_2} \right) \left( 1 - \frac{\text{RegisterValue} + 1}{256} \left( \frac{R_1}{20R_{SET}} \right) \right) \quad (\text{EQ. 8})$$

With amplifier A2 in the unity-gain configuration ( $V_{COM\_OUT}$  tied to  $IN_N$  as shown in Figure 5),  $V_{DVR\_OUT} = V_{COM\_OUT} = V_{COM}$ .

## Example

As an example, suppose the  $AV_{DD}$  supply is 15V, the desired  $V_{COM\_MIN} = 6.5V$  and the desired  $V_{COM\_MAX} = 8.5V$ .  $R_{SET}$  is arbitrarily chosen to be 7.5k $\Omega$ .

First, verify that our chosen  $R_{SET}$  meets the minimum requirement described in Equation 5:

$$(7.5\text{k}\Omega) > R_{SET(MIN)} = \left( \frac{\frac{15}{16}}{\left( 6.5V - \frac{15}{20} \right)} \right) = 0.163\text{k}\Omega \quad (\text{EQ. 9})$$

Using Equations 6 and 7, calculate the values of  $R_1$  and  $R_2$ :

$$R_1 = 5120 \cdot 7500 \cdot \left( \frac{8.5 - 6.5}{256 \cdot 8.5 - 6.5} \right) = 35.4\text{k}\Omega \quad (\text{EQ. 10})$$

$$R_2 = 5120 \cdot 7500 \cdot \left( \frac{8.5 - 6.5}{255 \cdot 15 + 6.5 - 256 \cdot 8.5} \right) = 46.4\text{k}\Omega \quad (\text{EQ. 11})$$

Table 1 shows the resulting  $V_{COM}$  voltage as a function of register value for these conditions.

TABLE 1. EXAMPLE  $V_{DVR\_OUT}$  vs REGISTER VALUE

REGISTER VALUE	$V_{DVR\_OUT}$ (V)
0	8.49
20	8.34
40	8.18
60	8.02
80	7.87
100	7.71
120	7.55
127	7.50
140	7.40
160	7.24
180	7.09
200	6.93
220	6.77
240	6.62
255	6.50

## Output Voltage Span Calculation

It is also possible to calculate  $V_{COM(MIN)}$  and  $V_{COM(MAX)}$  from the existing resistor values.

$V_{COM\_MIN}$  occurs when the greatest current,  $I_{DVR(MAX)}$ , is drawn from the middle node of the  $R_1/R_2$  divider. Substituting RegisterValue = 255 into Equation 8 gives the following:

$$V_{COM(MIN)} = AV_{DD} \left( \frac{R_2}{R_1 + R_2} \right) \left( 1 - \left( \frac{R_1}{20R_{SET}} \right) \right) \quad (\text{EQ. 12})$$

Similarly, RegisterValue = 0 for  $V_{COM(MAX)}$ :

$$V_{COM(MAX)} = AV_{DD} \left( \frac{R_2}{R_1 + R_2} \right) \left( 1 - \frac{1}{256} \left( \frac{R_1}{20R_{SET}} \right) \right) \quad (\text{EQ. 13})$$

By finding the difference of Equation 13 and Equation 12, the total span of  $V_{COM}$  can be found:

$$V_{COM\ SPAN} = AV_{DD} \left( \frac{R_2}{R_1 + R_2} \right) \left( 1 - \frac{1}{256} \right) \left( \frac{R_1}{20R_{SET}} \right) \quad (EQ. 14)$$

Assuming that the  $I_{DVR\ OUT(MIN)} = 0$  instead of  $I_{STEP}$ , the expression in Equation 14 simplifies to:

$$V_{COM\ SPAN} = \left( \frac{R_1 \cdot R_2}{R_1 + R_2} \right) \left( \frac{AV_{DD}}{20R_{SET}} \right) = \left( \frac{R_1 \cdot R_2}{R_1 + R_2} \right) I_{DVR\ OUT(MAX)} \quad (EQ. 15)$$

### DVR\_OUT Pin Leakage Current

When the voltage on the DVR\_OUT pin is greater than 10V, an additional leakage current flows into the pin in addition to the  $I_{SET}$  current. Figure 6 shows the  $I_{SET}$  current and the DVR\_OUT pin current for DVR\_OUT pin voltage up to 19V. In applications where the voltage on the DVR\_OUT pin will be greater than 10V, the actual output voltage will be lower than the voltage calculated by Equation 8. The graph in Figure 6 was measured with  $R_{SET} = 4.99k\Omega$ .

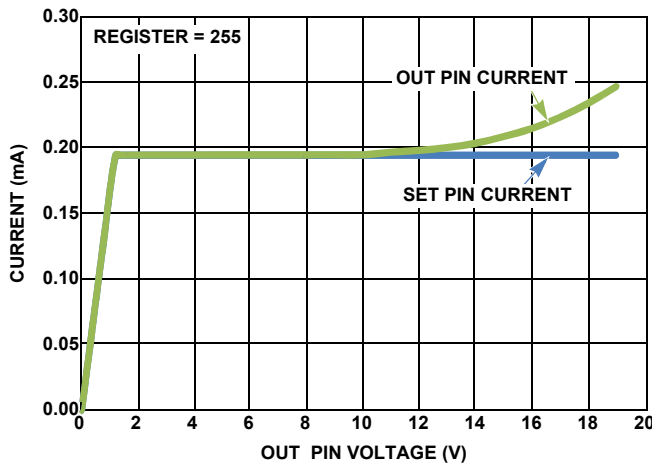

FIGURE 6. DVR\_OUT PIN LEAKAGE CURRENT

### Power Supply Sequence

The recommended power supply sequencing is shown in Figure 7. When applying power,  $V_{DD}$  should be applied before or at the same time as  $AV_{DD}$ . The minimum time for  $t_{VS}$  is 0µs. When removing power, the sequence of  $V_{DD}$  and  $AV_{DD}$  is not important.

Do not remove  $V_{DD}$  or  $AV_{DD}$  within 100ms of the start of the EEPROM programming cycle. Removing power before the EEPROM programming cycle is completed may result in corrupted data in the EEPROM.

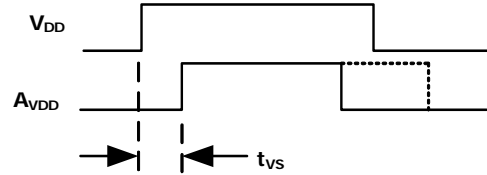

FIGURE 7. POWER SUPPLY SEQUENCE

### Operating and Programming Supply Voltage and Current

To program the EEPROM,  $AV_{DD}$  must be  $\geq 10.8V$ . If programming is not required, the ISL24211 will operate over an  $AV_{DD}$  range of 4.5V to 19V.

During EEPROM programming,  $I_{DD}$  and  $I_{AVDD}$  will temporarily be higher than their quiescent currents. Figure 8 shows a typical  $I_{DD}$  and  $I_{AVDD}$  current profile during EEPROM programming. The current pulses are Erase and Write cycles. The EEPROM programming algorithm is shown in Figure 9. The algorithm attempts up to 4 erase cycles and 4 programming cycles, however typical parts only require 1 cycle of each, sometimes 2 when  $AV_{DD}$  is near the minimum 10.8V limit.

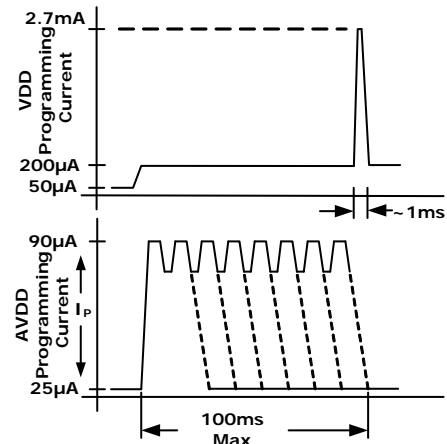

FIGURE 8.  $I_{DD}$  AND  $I_{AVDD}$  CURRENT PROFILE DURING EEPROM PROGRAMMING

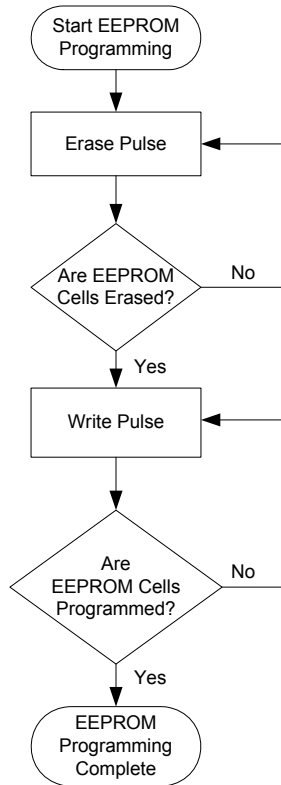

FIGURE 9. EEPROM PROGRAMMING FLOWCHART

## ISL24211 Programming

The ISL24211 accepts I<sup>2</sup>C bus address and data when the  $\overline{WP}$  pin is high. The ISL24211 ignores the I<sup>2</sup>C bus when the  $\overline{WP}$  pin is low. Figure 10 shows the serial data format for writing the register and programming the EEPROM. Figure 11 shows the serial data format for reading the DAC register. Table 2 shows the truth table for reading and writing the device.

TABLE 2. ISL24211 READ AND WRITE CONTROL

$\overline{WP}$ PIN	R/ $\overline{W}$	$\overline{P}$	FUNCTION
0	1	X	Read Register.
0	0	1	Will acknowledge I <sup>2</sup> C transactions. Will not write to register.
0	0	0	Will acknowledge I <sup>2</sup> C transactions. Will not write to EEPROM.
1	1	X	Read DAC Register.
1	0	1	Write DAC Register.
1	0	0	Program EEPROM.

Programming the EEPROM memory transfers the current DAC register value to the EEPROM and occurs when the control bits select the programming mode and the AV<sub>DD</sub> voltage is >10.8V. After the EEPROM programming cycle is started, the  $\overline{WP}$  pin can be returned to logic low while the EEPROM write completes, which takes a maximum of 100ms.

The ISL24211 uses a 6-bit I<sup>2</sup>C address, which is "100111yx" for the first transmitted byte. Bit x is the R/ $\overline{W}$  bit, and Bit y is the LSB (D0) of the DCP register code to be written. The complete read and write protocol is shown in Figures 10 and 11.

## I<sup>2</sup>C Bus Signals

The ISL24211 uses fixed voltages for its I<sup>2</sup>C thresholds, rather than the percentage of V<sub>DD</sub> described in the I<sup>2</sup>C specification (see Table 3). This should not cause a problem in most systems, but the I<sup>2</sup>C logic levels in a specific design should be checked to ensure they are compatible with the ISL24211.

TABLE 3. ISL24211 I<sup>2</sup>C BUS LOGIC LEVELS

SYMBOL	ISL24211	I <sup>2</sup> C STANDARD
V <sub>IL_I2C</sub>	0.55V	0.3*V <sub>DD</sub>
V <sub>IH_I2C</sub>	1.44V	0.7*V <sub>DD</sub>

# I<sup>2</sup>C Read and Write Format

## ISL24211 I<sup>2</sup>C Write

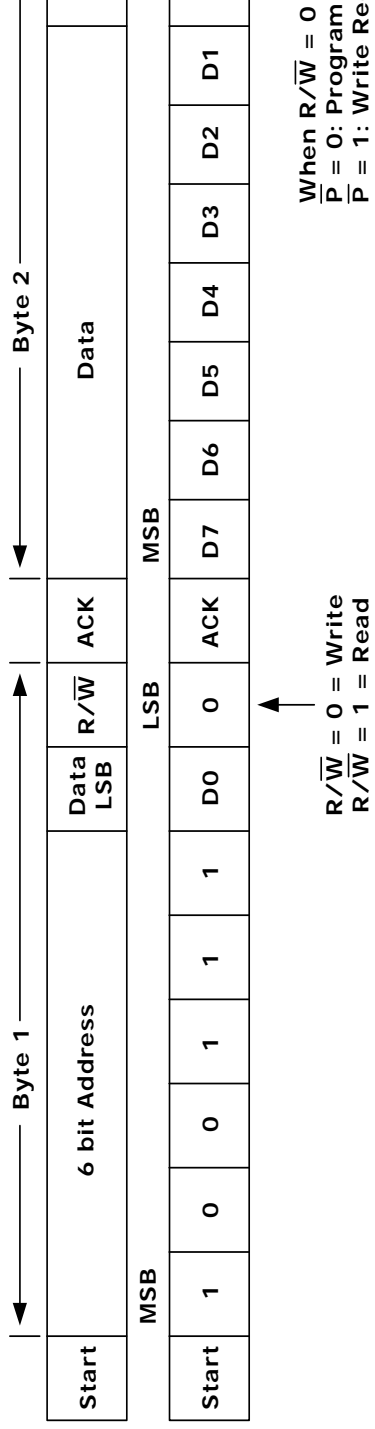

FIGURE 10. I<sup>2</sup>C WRITE FORMAT

## ISL24211 I<sup>2</sup>C Read

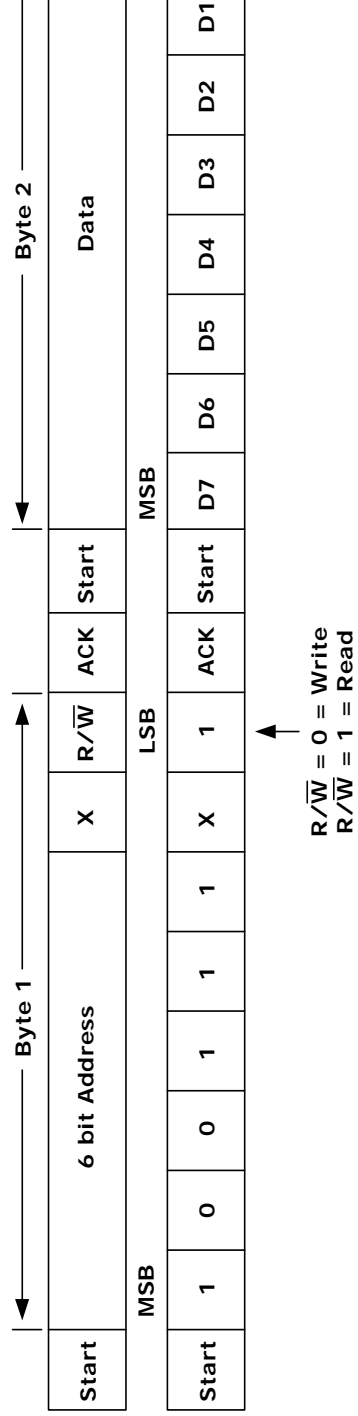

FIGURE 11. I<sup>2</sup>C READ FORMAT

## Revision History

The revision history provided is for informational purposes only and is believed to be accurate, but not warranted. Please go to web to make sure you have the latest revision.

DATE	REVISION	CHANGE
2/23/11	FN7585.0	Initial Release.

## Products

Intersil Corporation is a leader in the design and manufacture of high-performance analog semiconductors. The Company's products address some of the industry's fastest growing markets, such as, flat panel displays, cell phones, handheld products, and notebooks. Intersil's product families address power management and analog signal processing functions. Go to [www.intersil.com/products](http://www.intersil.com/products) for a complete list of Intersil product families.

\*For a complete listing of Applications, Related Documentation and Related Parts, please see the respective device information page on intersil.com: [ISL24211](http://www.intersil.com/ISL24211)

To report errors or suggestions for this datasheet, please go to [www.intersil.com/askourstaff](http://www.intersil.com/askourstaff)

FITs are available from our website at <http://rel.intersil.com/reports/search>

© Copyright Intersil Americas LLC 2011. All Rights Reserved.

All trademarks and registered trademarks are the property of their respective owners.

For additional products, see [www.intersil.com/en/products.html](http://www.intersil.com/en/products.html)

Intersil products are manufactured, assembled and tested utilizing ISO9001 quality systems as noted in the quality certifications found at [www.intersil.com/en/support/qualandreliability.html](http://www.intersil.com/en/support/qualandreliability.html)

*Intersil products are sold by description only. Intersil may modify the circuit design and/or specifications of products at any time without notice, provided that such modification does not, in Intersil's sole judgment, affect the form, fit or function of the product. Accordingly, the reader is cautioned to verify that datasheets are current before placing orders. Information furnished by Intersil is believed to be accurate and reliable. However, no responsibility is assumed by Intersil or its subsidiaries for its use; nor for any infringements of patents or other rights of third parties which may result from its use. No license is granted by implication or otherwise under any patent or patent rights of Intersil or its subsidiaries.*

For information regarding Intersil Corporation and its products, see [www.intersil.com](http://www.intersil.com)

# Package Outline Drawing

## L10.3x3A

10 LEAD THIN DUAL FLAT NO-LEAD PLASTIC PACKAGE

Rev 5, 3/10

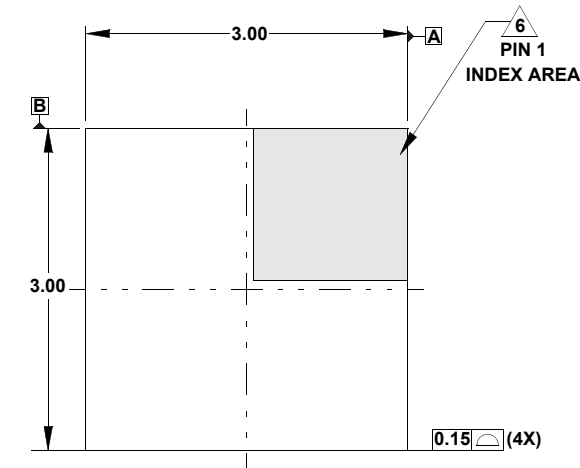

TOP VIEW

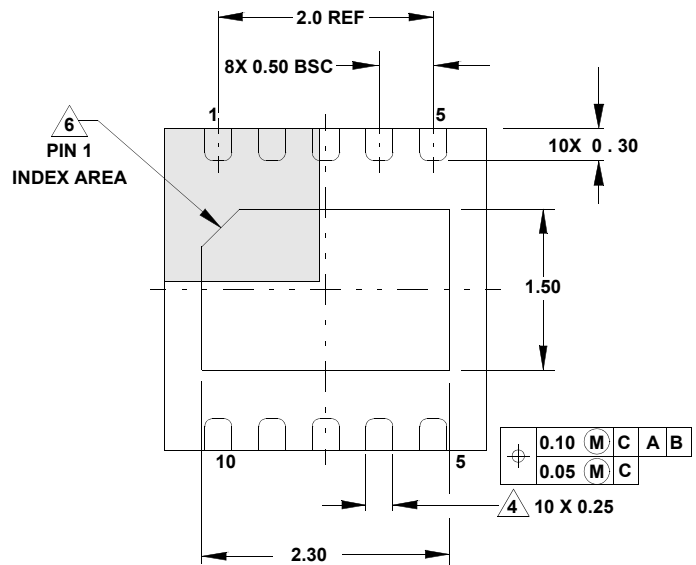

BOTTOM VIEW

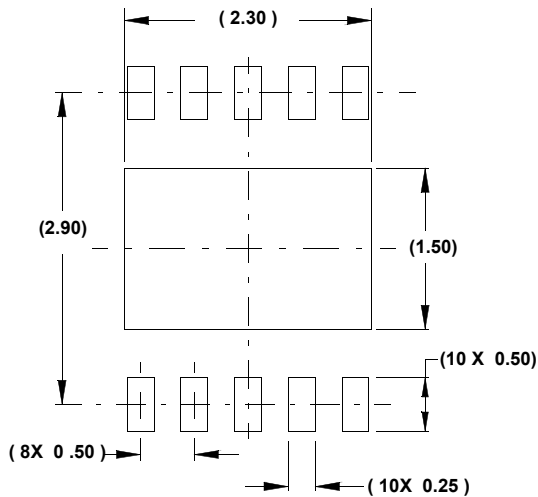

TYPICAL RECOMMENDED LAND PATTERN

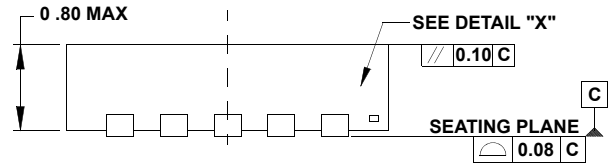

SIDE VIEW

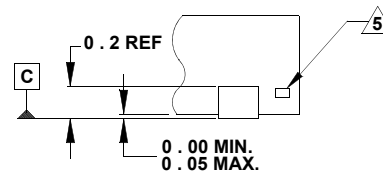

DETAIL "X"

NOTES:

1. Dimensions are in millimeters.  
Dimensions in ( ) for Reference Only.
2. Dimensioning and tolerancing conform to ASME Y14.5m-1994.
3. Unless otherwise specified, tolerance : Decimal  $\pm 0.05$   
Angular  $\pm 2.50^\circ$
4. Dimension applies to the metallized terminal and is measured between 0.15mm and 0.30mm from the terminal tip.
5. Tiebar shown (if present) is a non-functional feature.
6. The configuration of the pin #1 identifier is optional, but must be located within the zone indicated. The pin #1 identifier may be either a mold or mark feature.
7. Compliant to JEDEC MO-229-WEED-3 except exposed pad length (2.30mm).

## Looking for pricing, stock, or lifecycle information?

Click below to explore more details on WIN SOURCE:

- ⊖ [View ISL24211IRTZ on WIN SOURCE](#)
- ⊖ [Renesas Electronics America](#) Information

## Optimize Your Supply Chain with WIN SOURCE Solutions

- ✓ Global Sourcing Solution
- ✓ Obsolete Management
- ✓ Cost Control Management
- ✓ Shortage Management
- ✓ Alternative Solution
- ✓ Excess Inventory Management