

IS31FL3199

9-CHANNEL LIGHT EFFECT LED DRIVER

October 2018

GENERAL DESCRIPTION

IS31FL3199 is a 9-channel light effect LED driver which features two-dimensional auto breathing mode and an audio modulated display mode. It has One Shot Programming mode and PWM Control mode for RGB lighting effects. The maximum output current can be adjusted in 8 levels (5mA~40mA).

In PWM Control mode, the PWM duty cycle of each output can be independently programmed and controlled in 256 steps to simplify color mixing. In One Shot Programming mode, the timing characteristics for output current - current rising, holding, falling and off time, can be adjusted individually so that each output can independently maintain a pre-established pattern achieving mixing color breathing or a single color breathing without requiring any additional interface activity, thus saving valuable system resources.

The IS31FL3199 includes an audio modulated display mode, wherein the brightness of LED can be modulated by audio signal. There is a cascade pin for the synchronization of two chips.

IS31FL3199 is available in QFN-20 (3mm × 3mm). It operates from 2.7V to 5.5V over the temperature range of -40°C to +85°C.

FEATURES

- 2.7V to 5.5V supply voltage
- I2C interface, automatic address increment function
- Three groups RGB, single color LED breathing system-free pre-established pattern
- 9 independently controlled automatic and semiautomatic breathing system-free pre-established pattern
- 9 independently controlled outputs of 256 PWM steps
- 8 levels programmable output current
- Audio mode with AGC function
- Cascade for the synchronization of chips
- Over-temperature protection
- QFN-20 (3mm × 3mm) package

APPLICATIONS

- Mobile phones and other hand-held devices for LED display
- LED in home appliances

TYPICAL APPLICATION CIRCUIT

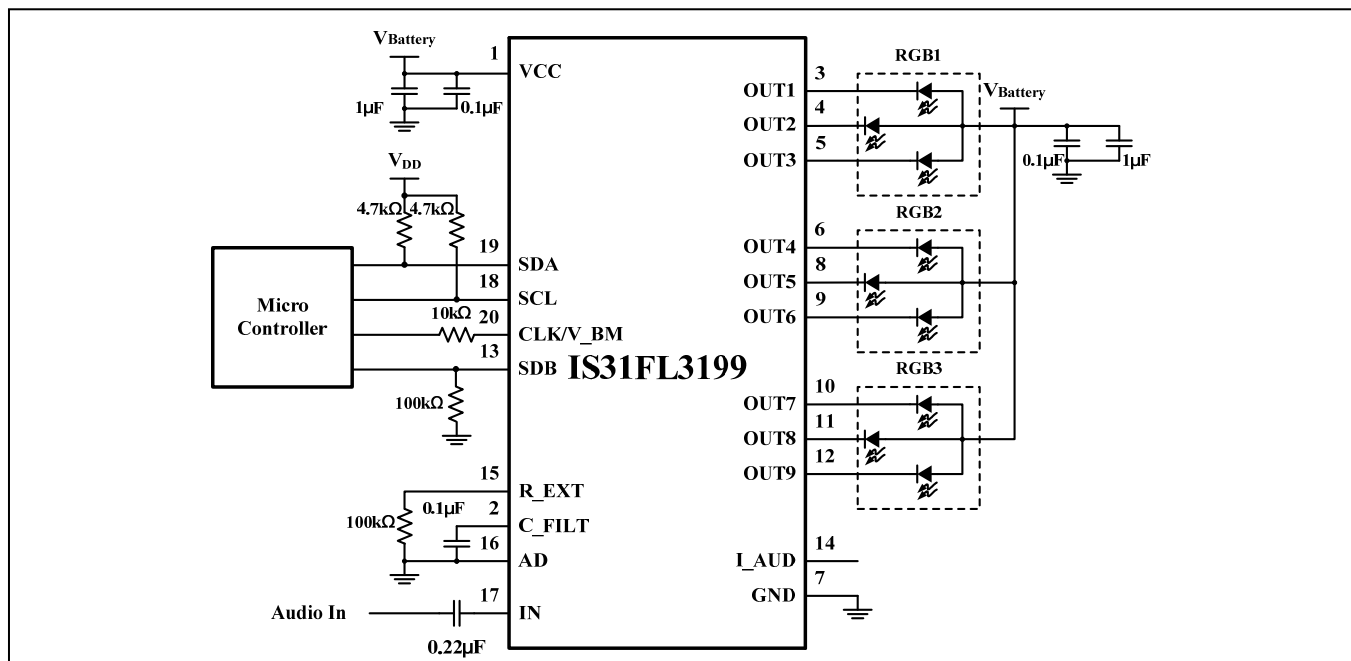

Figure 1 Typical Application Circuit

Note 1: IC should be placed far away from the antenna in order to prevent the EMI.

Note 2: The V_{IH} of I2C bus (V_{DD} as above) should be smaller than V_{CC} . And if V_{IH} is lower than 3.0V, it is recommended add a level shift circuit to avoid extra shutdown current.

IS31FL3199

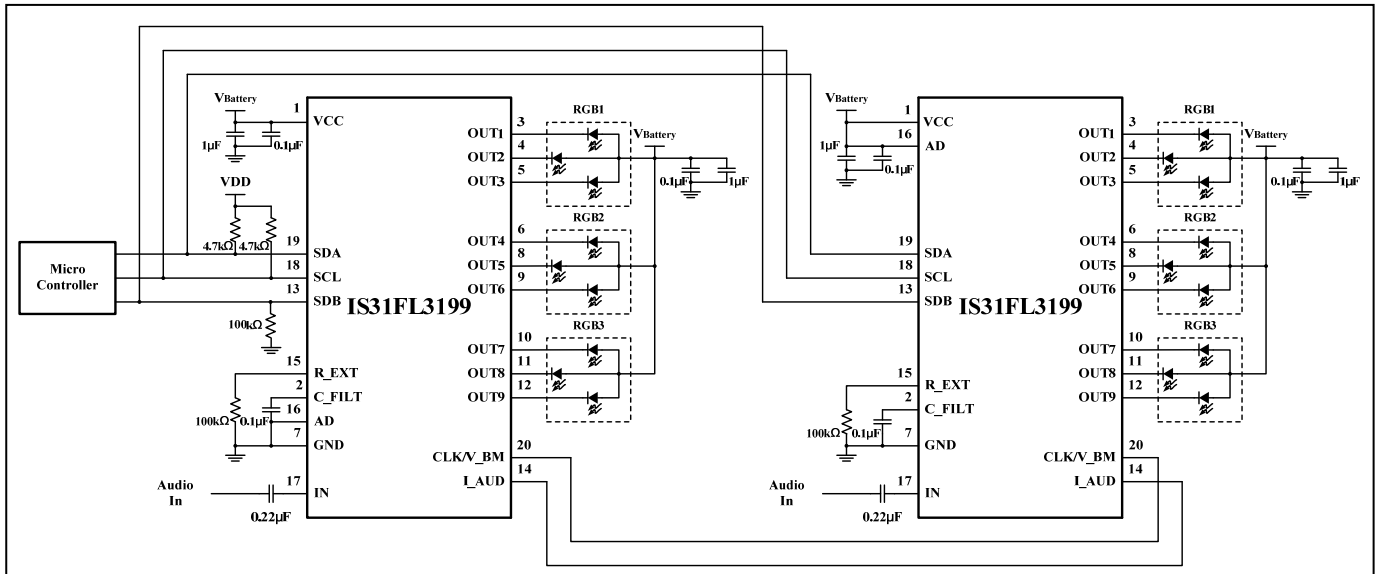
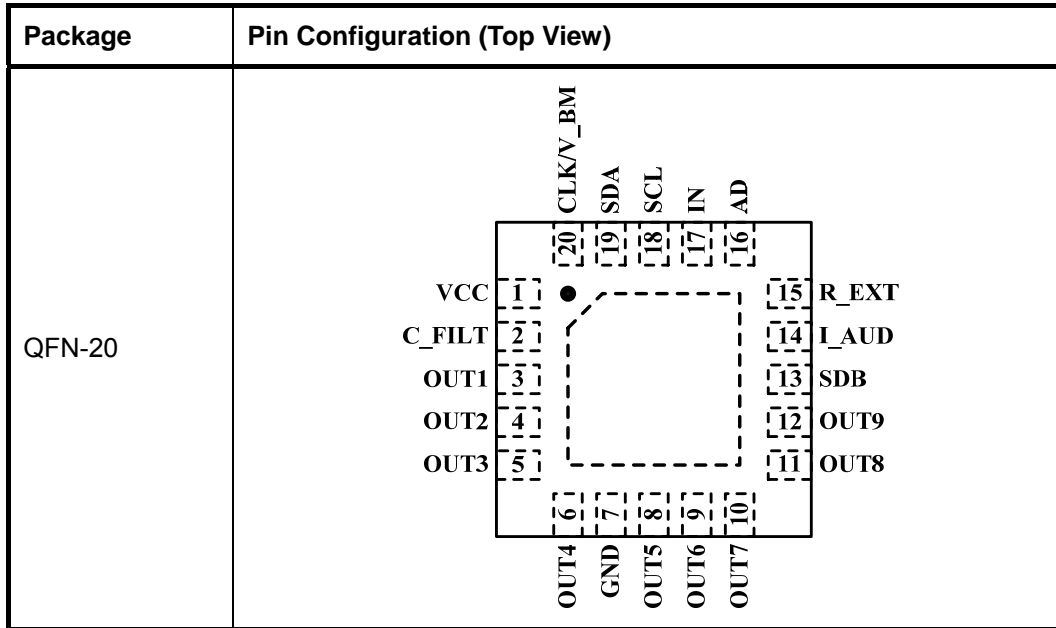

Figure 2 Typical Application Circuit (Cascade Mode)

Note 3: One system should contain only one clock master, all slave parts should be configured as slave mode before the master is configured as master mode. Work as master mode or slave mode specified by Configuration Register-2 (CM bit, register 04h). Master part output master clock, and all the other parts which work as slave input this master clock.

IS31FL3199

PIN CONFIGURATION



PIN DESCRIPTION

| No. | Pin | Description |
|------|-------------|---|
| 1 | VCC | Power supply. |
| 2 | C_FILT | Filter capacitor for audio control. |
| 3~6 | OUT1~OUT4 | Current source outputs. |
| 7 | GND | Ground. |
| 8~12 | OUT5~OUT9 | Current source outputs. |
| 13 | SDB | Shutdown the chip when pulled to low. |
| 14 | I_AUD | Audio current input or output for cascade. |
| 15 | R_EXT | Input terminal used to connect an external resistor. The value must be about 100kΩ. |
| 16 | AD | I2C address setting. |
| 17 | IN | Audio input. |
| 18 | SCL | I2C serial clock. |
| 19 | SDA | I2C serial data. |
| 20 | CLK/V_BM | CLK input or output for cascade. When breathing mark function enable, this pin is V_BM pin. |
| | Thermal Pad | Connect to GND. |

IS31FL3199

ORDERING INFORMATION

Industrial Range: -40°C to +85°C

| Order Part No. | Package | QTY/Reel |
|---------------------|-------------------|----------|
| IS31FL3199-QFLS2-TR | QFN-20, Lead-free | 2500 |

Copyright © 2018 Lumissil Microsystems. All rights reserved. Lumissil Microsystems reserves the right to make changes to this specification and its products at any time without notice. Lumissil Microsystems assumes no liability arising out of the application or use of any information, products or services described herein. Customers are advised to obtain the latest version of this device specification before relying on any published information and before placing orders for products.

Lumissil Microsystems does not recommend the use of any of its products in life support applications where the failure or malfunction of the product can reasonably be expected to cause failure of the life support system or to significantly affect its safety or effectiveness. Products are not authorized for use in such applications unless Lumissil Microsystems receives written assurance to its satisfaction, that:

- a.) the risk of injury or damage has been minimized;
- b.) the user assume all such risks; and
- c.) potential liability of Lumissil Microsystems is adequately protected under the circumstances

IS31FL3199

ABSOLUTE MAXIMUM RATINGS

| | |
|--|-----------------------|
| Supply voltage, V_{CC} | -0.3V ~ +6.0V |
| Voltage at any OUTx pins | -0.3V ~ $V_{CC}+0.3V$ |
| Voltage at any input pin | -0.3V ~ $V_{CC}+0.3V$ |
| GND terminal current | 400mA |
| Maximum junction temperature, T_{JMAX} | 150°C |
| Storage temperature range, T_{STG} | -65°C ~ +150°C |
| Operating temperature range, $T_A = T_J$ | -40°C ~ +85°C |
| Package thermal resistance, junction to ambient (4 layer standard test PCB based on JESD 51-2A), θ_{JA} | 58.1°C/W |
| ESD (HBM) | ±2kV |
| ESD (CDM) | ±1kV |

Note 4: Stresses beyond those listed under “Absolute Maximum Ratings” may cause permanent damage to the device. These are stress ratings only and functional operation of the device at these or any other condition beyond those indicated in the operational sections of the specifications is not implied. Exposure to absolute maximum rating conditions for extended periods may affect device reliability.

ELECTRICAL CHARACTERISTICS

$T_A = -40^\circ\text{C} \sim +85^\circ\text{C}$, unless otherwise noted. Typical value are $T_A = 25^\circ\text{C}$, $V_{CC} = 5V$.

| Symbol | Parameter | Condition | Min. | Typ. | Max. | Unit |
|-----------|--------------------------------|---|------|----------------|------|---------------|
| V_{CC} | Supply voltage | | 2.7 | | 5.5 | V |
| I_{CC} | Quiescent power supply current | $V_{SDB} = V_{CC}$ | | 3 | | mA |
| I_{SD} | Shutdown current | $V_{SDB} = 0V$ | | 1 | | μA |
| | | $V_{SDB} = V_{CC}$, software shutdown | | 2 | | |
| I_{OUT} | Output current | PWM Control Mode, $V_{DS} = 0.4V$ PWM Register(07h~0Fh) = 0xFF | | 20 (Note 5) | | mA |
| | | Audio Mode, Gain = 12dB $V_{IN} = 0.8V_{P-P}$, 1kHz square wave | | 18 (Note 5) | | |
| V_{HR} | Current sink headroom voltage | $I_{OUT} = 20\text{mA}$ | | 400 | | mV |

Logic Electrical Characteristics (SDA, SCL, SDB, AD)

| | | | | | | |
|----------|-------------------------|--------------------------------|-----|---------------|-----|----|
| V_{IL} | Logic “0” input voltage | $V_{CC} = 2.7V \sim 5.5V$ | | | 0.4 | V |
| V_{IH} | Logic “1” input voltage | $V_{CC} = 2.7V \sim 5.5V$ | 1.4 | | | V |
| I_{IL} | Logic “0” input current | SSD= “0”, $V_{INPUT} = 0V$ | | 5 (Note 6) | | nA |
| I_{IH} | Logic “1” input current | SSD= “0”, $V_{INPUT} = V_{CC}$ | | 5 (Note 6) | | nA |

IS31FL3199

DIGITAL INPUT SWITCHING CHARACTERISTICS (Note 6)

| Symbol | Parameter | Condition | Standard Mode | | | Fast Mode | | | Unit |
|---------------|---|-----------|---------------|------|------|-----------|-------------|------|---------|
| | | | Min. | Typ. | Max. | Min. | Typ. | Max. | |
| f_{SCL} | Serial-Clock frequency | | | | 100 | | | 400 | kHz |
| t_{BUF} | Bus free time between a STOP and a START condition | | 4.7 | | | 1.3 | | | μ s |
| $t_{HD, STA}$ | Hold time (repeated) START condition | | 4.0 | | | 0.6 | | | μ s |
| $t_{SU, STA}$ | Repeated START condition setup time | | 4.7 | | | 0.6 | | | μ s |
| $t_{SU, STO}$ | STOP condition setup time | | 4.0 | | | 0.6 | | | μ s |
| $t_{HD, DAT}$ | Data hold time (Note 7) | | 0 | | 3.45 | 0 | | 0.9 | μ s |
| $t_{SU, DAT}$ | Data setup time (Note 8) | | 250 | | | 100 | | | ns |
| t_{LOW} | SCL clock low period | | 4.7 | | | 1.3 | | | μ s |
| t_{HIGH} | SCL clock high period | | 4.0 | | | 0.7 | | | μ s |
| t_R | Rise time of both SDA and SCL signals, receiving (Note 9) | | | | 1000 | | $20+0.1C_b$ | 300 | ns |
| t_F | Fall time of both SDA and SCL signals, receiving (Note 9) | | | | 300 | | $20+0.1C_b$ | 300 | ns |

Note 5: The average current of each channel is I_{OUT} .

Note 6: Guaranteed by design.

Note 7: The minimum $t_{HD, DAT}$ measured start from $V_{IL(max)}$ of SCL signal. The maximum $t_{HD, DAT}$ has only to be met if the device does not stretch the LOW period (t_{LOW}) of the SCL signal. $V_{IL(max)}$

Note 8: A Fast-mode I2C-bus device can be used in a Standard-mode I2C-bus system, but the requirement $t_{SU, DAT} \geq 250$ ns must then be met. This will automatically be the case if the device does not stretch the LOW period of the SCL signal. If such a device does stretch the LOW period of the SCL signal, it must output the next data bit to the SDA line $t_R \max + t_{SU, DAT} = 1000 + 250 = 1250$ ns (according to the Standard-mode I2C-bus specification) before the SCL line is released.

Note 9: C_b = total capacitance of one bus line in pF. $I_{SINK} \leq 6$ mA. t_R and t_F measured between $0.3 \times V_{CC}$ and $0.7 \times V_{CC}$.

IS31FL3199

DETAILED DESCRIPTION

I2C INTERFACE

The IS31FL3199 uses a serial bus, which conforms to the I2C protocol, to control the chip's functions with two wires: SCL and SDA. The IS31FL3199 has a 7-bit slave address (A7:A1), followed by the R/W bit, A0. Since IS31FL3199 only supports write operations, A0 must always be "0". The value of bits A1 and A2 are decided by the connection of the AD pin.

The complete slave address is:

Table 1 Slave Address (Write Only):

| Bit | A7:A3 | A2:A1 | A0 |
|-------|-------|-------|----|
| Value | 11001 | AD | 0 |

- AD connected to GND, AD = 00;
- AD connected to VCC, AD = 11;
- AD connected to SCL, AD = 01;
- AD connected to SDA, AD = 10;

The SCL line is uni-directional. The SDA line is bi-directional (open-collector) with a pull-up resistor (typically 4.7kΩ). The maximum clock frequency specified by the I2C standard is 400kHz. In this discussion, the master is the microcontroller and the slave is the IS31FL3199.

The timing diagram for the I2C is shown in Figure 3. The SDA is latched in on the stable high level of the SCL. When there is no interface activity, the SDA line should be held high.

The "START" signal is generated by lowering the SDA signal while the SCL signal is high. The start signal will alert all devices attached to the I2C bus to check the incoming address against their own chip address.

The 8-bit chip address is sent next, most significant bit first. Each address bit must be stable while the SCL level is high.

After the last bit of the chip address is sent, the master checks for the IS31FL3199's acknowledge. The master releases the SDA line high (through a pull-up resistor). Then the master sends an SCL pulse. If the IS31FL3199 has received the address correctly, then it holds the SDA line low during the SCL pulse. If the SDA line is not low, then the master should send a "STOP" signal (discussed later) and abort the transfer.

Following acknowledge of IS31FL3199, the register address byte is sent, most significant bit first. IS31FL3199 must generate another acknowledge indicating that the register address has been received.

Then 8-bit of data byte are sent next, most significant bit first. Each data bit should be valid while the SCL level is stable high. After the data byte is sent, the IS31FL3199 must generate another acknowledge to indicate that the data was received.

The "STOP" signal ends the transfer. To signal "STOP", the SDA signal goes high while the SCL signal is high.

ADDRESS AUTO INCREMENT

To write multiple bytes of data into IS31FL3199, load the address of the data register that the first data byte is intended for. During the IS31FL3199 acknowledge of receiving the data byte, the internal address pointer will increment by one. The next data byte sent to IS31FL3199 will be placed in the new address, and so on (Figure 6).

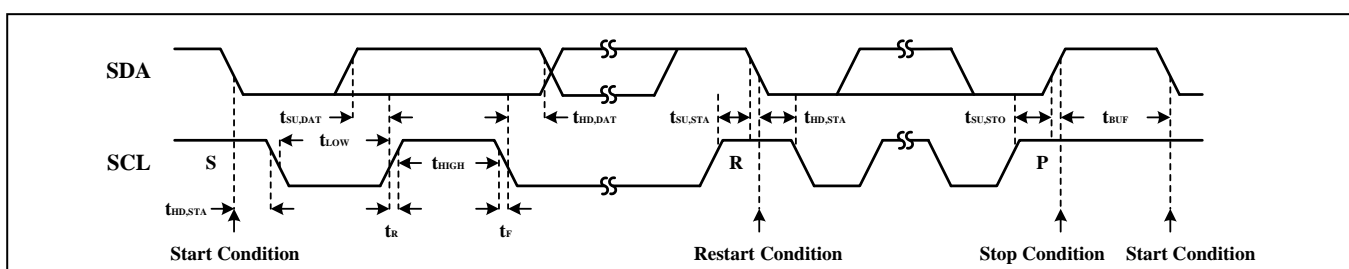

Figure 3 Interface Timing

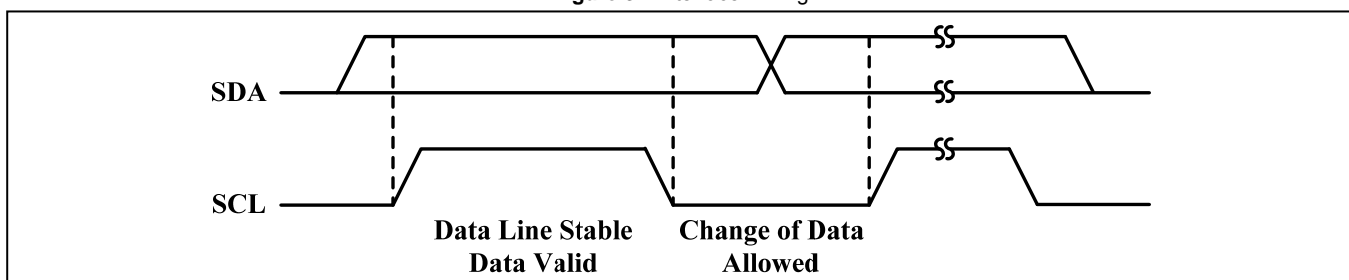

Figure 4 Bit Transfer

IS31FL3199

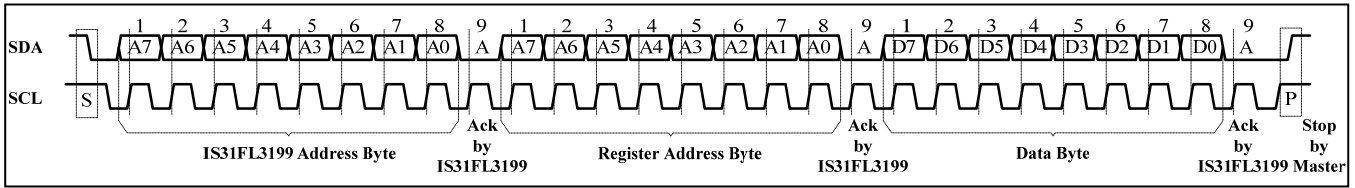

Figure 5 Writing to IS31FL3199(Typical)

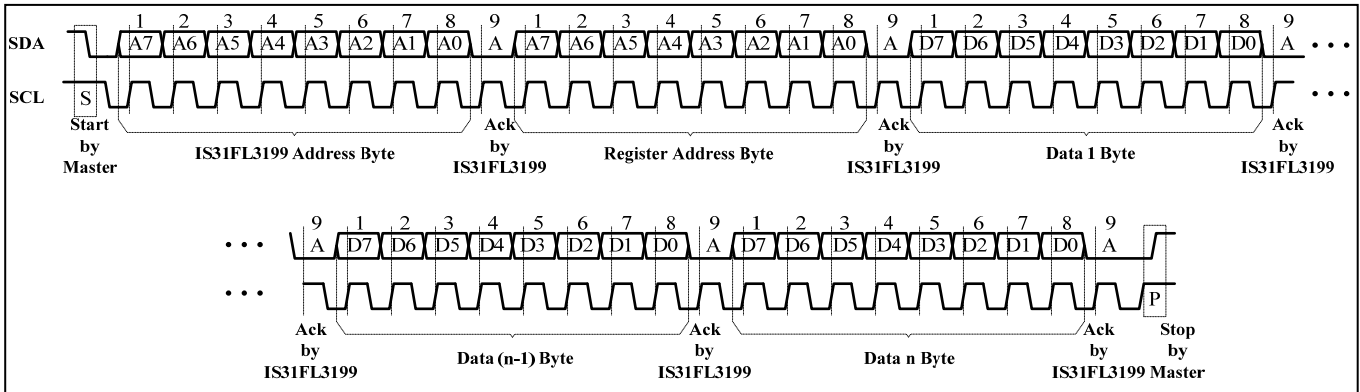

Figure 6 Writing to IS31FL3199(Automatic Address Increment)

REGISTERS DEFINITIONS

Table 2 Register Function

| Address | Name | Function | Table | Default |
|-----------|--------------------------|--|-------|-----------|
| 00h | Shutdown Register | Set software shutdown mode | 3 | 0000 0000 |
| 01h | LED Control Register 1 | OUT1~ OUT6 enable bit | 4 | 0111 0111 |
| 02h | LED Control Register 2 | OUT7~ OUT9 enable bit | 5 | 0000 0111 |
| 03h | Configuration Register 1 | Set operation mode | 6 | 0000 0000 |
| 04h | Configuration Register 2 | Set output current and audio input gain | 7 | |
| 05h | Ramping Mode Register | Set the ramping function mode | 8 | |
| 06h | Breathing Mark Register | Set the breathing mark function | 9 | |
| 07h ~ 0Fh | PWM Register | 9 channels PWM duty cycle data registers | 10 | |
| 10h | Data Update Register | Load PWM Registers and LED Control Registers' data | - | xxxx xxxx |
| 11h ~ 19h | T0 Register | Set the T0 time | 11 | 0000 0000 |
| 1Ah ~ 1Ch | T1~T3 Register | Set the T1~T3 time | 12 | |
| 1Dh ~ 25h | T4 Register | Set the T4 time | 13 | |
| 26h | Time Update Register | Load time registers' data | - | xxxx xxxx |
| FFh | Reset Register | Reset all registers to default value | - | |

IS31FL3199

Table 3 00h Shutdown Register

| Bit | D7:D1 | D0 |
|---------|----------|-----|
| Name | - | SSD |
| Default | 0000 000 | 0 |

The Shutdown Register sets software shutdown mode of IS31FL3199.

SSD Software Shutdown Enable
 0 Software shutdown mode
 1 Normal operation

Table 4 01h LED Control Register 1(OUT1~OUT6)

| Bit | D7 | D6:D4 | D3 | D2:D0 |
|---------|----|-----------|----|-----------|
| Name | - | OUT6:OUT4 | - | OUT3:OUT1 |
| Default | 0 | 111 | 0 | 111 |

Table 5 02h LED Control Register 2(OUT7~OUT9)

| Bit | D7:D3 | D2:D0 |
|---------|--------|-----------|
| Name | - | OUT9:OUT7 |
| Default | 0000 0 | 111 |

The LED Control Registers store the on or off state of each channel LED.

OUTx LED State
 0 LED off
 1 LED on

Table 6 03h Configuration Register 1

| Bit | D7 | D6:D4 | D3 | D2 | D1 | D0 |
|---------|----|--------|----|----|------|------|
| Name | - | RGB3:1 | - | AE | AGCE | AGCM |
| Default | 0 | 000 | 0 | 0 | 0 | 0 |

The Configuration Register 1 sets operation mode.

RGBx RGB Mode Selection
 0 PWM Control Mode
 1 One Shot Programming Mode

AE Audio Modulate Enable
 0 Disable
 1 Enable

AGCE AGC Function Enable
 0 Enable
 1 Disable

AGCM AGC Mode Selection
 0 Mode1 (Fast Modulation)
 1 Mode2 (Slow Modulation)

Table 7 04h Configuration Register 2

| Bit | D7 | D6:D4 | D3 | D2:D0 |
|---------|----|-------|----|-------|
| Name | CM | CS | - | AGS |
| Default | 0 | 000 | 0 | 000 |

The Configuration Register 2 stores the intensity control settings for all of the LEDs and the control mode.

CM Control Mode
 0 Master
 1 Slave

CS Current Setting
 000 20mA
 001 15mA
 010 10mA
 011 5mA
 100 40mA
 101 35mA
 110 30mA
 111 25mA

AGS Audio Gain Selection
 000 Gain= 0dB
 001 Gain= 3dB
 010 Gain= 6dB
 011 Gain= 9dB
 100 Gain= 12dB
 101 Gain= 15dB
 110 Gain= 18dB
 111 Gain= 21dB

Table 8 05h Ramping Mode Register

| Bit | D7 | D6:D4 | D3 | D2:D0 |
|---------|----|------------|----|------------|
| Name | - | RM(RGB3:1) | - | HT(RGB3:1) |
| Default | 0 | 000 | 0 | 000 |

The Ramping Mode Register sets the ramping function.

RM Ramping Mode Enable
 0 Disable
 1 Enable

HT Hold Time Selection
 0 Breathing Hold on T2
 1 Breathing Hold on T4

IS31FL3199

Table 9 06h Breathing Mark Register

| Bit | D7:D5 | D4 | D3:D0 |
|---------|-------|-----|-------|
| Name | - | BME | CSS |
| Default | 000 | 0 | 0000 |

The Breathing Mark Register sets the breathing mark function (Detail information refers to Page 11).

BME Breathing Mark Enable
 0 Disable
 1 Enable

CSS Channel Selection
 0000 OUT1
 0001 OUT2
 0010 OUT3
 0011 OUT4
 0100 OUT5
 0101 OUT6
 0110 OUT7
 0111 OUT8
 1000 OUT9
 Others Not available

Table 10 07h~0Fh PWM Register(OUT1~OUT9)

| Bit | D7:D0 |
|---------|-----------|
| Name | PWM |
| Default | 0000 0000 |

The PWM Registers can modulate RGB light with 256 different items.

The value of PWM Registers decide the average output current of OUT1~OUT9. The average output current may be computed using the Formula (1):

$$I_{OUT} = \frac{I_{MAX}}{256} \cdot \sum_{n=0}^7 D[n] \cdot 2^n \quad (1)$$

Where “n” indicates the bit location in the respective PWM register.

For example: D7:D0 = 10110101,

$$I_{OUT} = I_{MAX} (2^0 + 2^2 + 2^4 + 2^5 + 2^7) / 256$$

I_{MAX} is set by Configuration Register2 (04h).

10h Data Update Register

The data sent to the PWM Registers and the LED Control Registers will be stored in temporary registers. A write operation of “0000 0000” data to the Data Update Register is required to update the registers (01h~02h, 07h~0Fh).

Table 11 11h~19h T0 Register (OUT1~OUT9)

| Bit | D7:D6 | D5:D4 | D3:D0 |
|---------|-------|-------|-------|
| Name | - | B | A |
| Default | 00 | 00 | 0000 |

The T0 Registers set the T0 time in One Shot Programming Mode.

$$T0 = \tau \times A \times 2^B$$

A = 0~15, B = 0~3 and $\tau = 260\text{ms}$ (Typ.)

For example, the max T0 is $260\text{ms} \times 15 \times 2^3 = 31.2\text{s}$

Table 12 1Ah~1Ch T1~T3 Register (RGB1~RGB3)

| Bit | D7 | D6:D4 | D3 | D2:D0 |
|---------|----|-------|----|-------|
| Name | DT | B | - | A |
| Default | 0 | 000 | 0 | 000 |

The T1~T3 Registers set the T1~T3 time in One Shot Programming Mode.

DT Double Time
 0 $T3 = T1$
 1 $T3 = 2T1$

If A = 0~4, $T1 = T3 = \tau \times 2^A$, $\tau = 260\text{ms}$ (Typ.)

If A = 5~6, the breathing function disable.

If A = 7, $T1 = T3 = 0.1\text{ms}$

If B = 1~7, $T2 = \tau \times 2^{B-1}$, $\tau = 260\text{ms}$ (Typ.)

If B = 0, $T2 = 0\text{s}$.

For example, the max T1&T3 is $260\text{ms} \times 2^4 = 4.16\text{s}$

The max T2 is $260\text{ms} \times 2^6 = 16.64\text{s}$

Table 13 1Dh~25h T4 Register (OUT1~OUT9)

| Bit | D7:D6 | D5:D4 | D3:D0 |
|---------|-------|-------|-------|
| Name | - | B | A |
| Default | 00 | 00 | 0000 |

The T4 Registers set the T4 time in One Shot Programming Mode.

$$T4 = \tau \times A \times 2^B$$

A = 0~15, B = 0~3 and $\tau = 260\text{ms}$ (Typ.)

For example, the max T4 is $260\text{ms} \times 15 \times 2^3 = 31.2\text{s}$

26h Time Update Register

The data sent to the time registers (11h~25h) will be stored in temporary registers. A write operation of “0000 0000” data to the Time Update Register is required to update the registers (11h~25h).

IS31FL3199

FFh Reset Register

Once user writes "0000 0000" data to the Reset Register, IS31FL3199 will reset all registers to default value. On initial power-up, the IS31FL3199 registers are reset to their default values for a blank display.

IS31FL3199

FUNCTIONAL BLOCK DIAGRAM

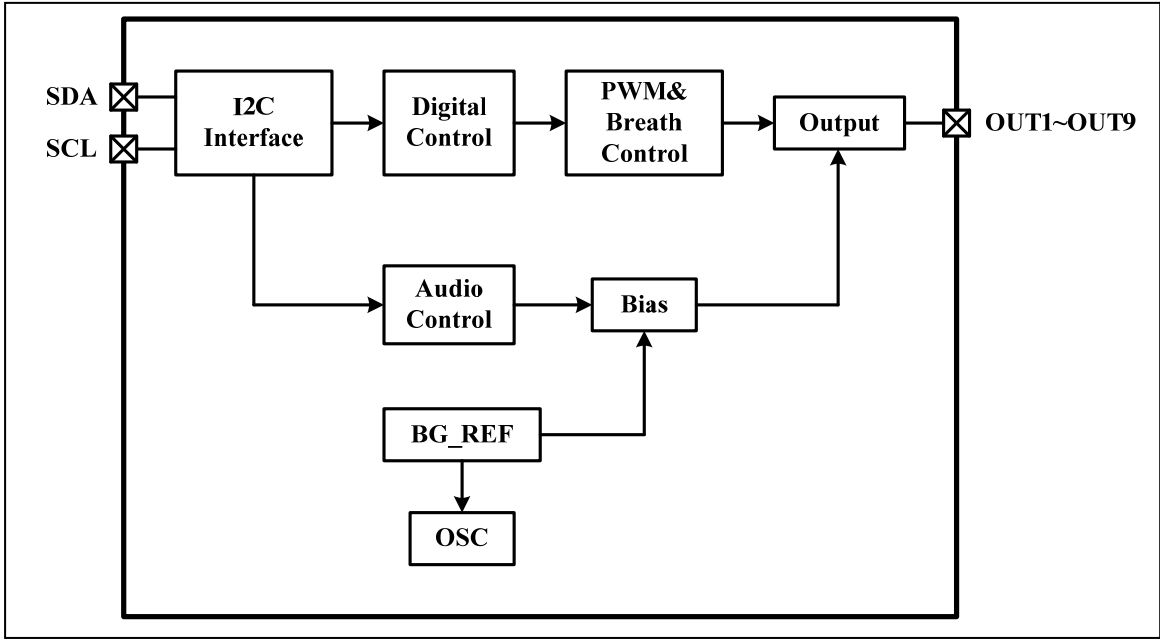

IS31FL3199

TYPICAL APPLICATION

GENERAL DESCRIPTION

IS31FL3199 is a 9-channel LED driver with two-dimensional auto breathing and PWM Control mode. It can drive nine LEDs or three groups RGB.

POWER ON SEQUENCE

IS31FL3199 provides a power-on reset feature that is controlled by V_{BAT} (voltage at pin1) supply voltage. When the V_{BAT} exceeds 2.0V (POR_H, Typ.), the internal circuit starts to work. The reset signal will be generated to perform a power-on reset (POR_H) operation, which will reset all control circuits and configuration registers until the internal power voltage become stable.

Before SDB pull high, the I2C operation is allowed. The SDB rising edge will reset the I2C bus.

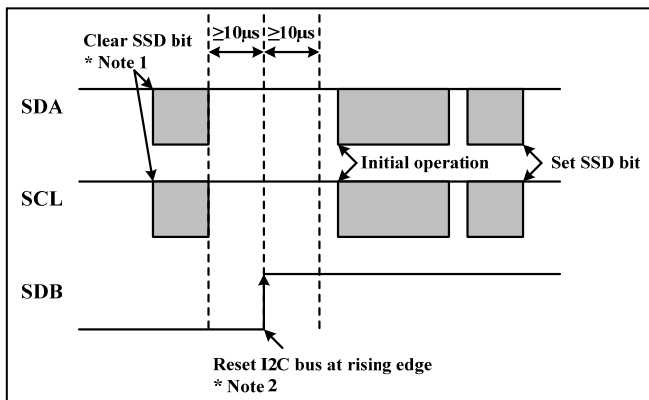

Figure 7 SDB Pin Sequence

Note 1: I2C operation is allowed when SDB is low.

Note 2: There should be no I2C operation 10µs before and after SDB rising edge.

In some case, like a mouse, when plug-out and quickly plug-in back the USB power, the LED will flash for a very short time. The reason is the power is not lower than the POR_L voltage point 1.92V (Typ.), and the device still stores the previous setting data, if user pull-up the SDB high when power up, following with the initial operation, the LED will be ON between SDB rising edge and PWM initial effective, to avoid this, as above figure, a writing to 00h is recommended to shutdown the chip before pull-high the SDB pin.

PWM CONTROL

By setting the RGBx bits of the Configuration Register1 (03h) to "0", the IS31FL3199 will operate in PWM Control mode. The PWM Registers (07h~0Fh) can modulate LED brightness of 9 channels with 256 steps. For example, if the data in PWM Register is "0000 0100", then the PWM is the fourth step.

Writing new data continuously to the registers can modulate the brightness of the LEDs to achieve a breathing effect.

RGB BREATHING CONTROL WITH AUTO COLOR CHANGING

By setting the RGBx bits of the Configuration Register1 (03h) to "1", the IS31FL3199 will operate in One Shot Programming mode. In this mode each group RGB can be modulated breathing cycle independently by T0~T4. The full cycle is T1 to T4 (Figure 8). Setting different T0~T4 can achieve RGB breathing with auto color changing. The maximum intensity of each RGB can be adjusted independently by the PWM Registers (07h~0Fh).

Note, if IS31FL3199 operates in the One Shot Programming mode and then enters into the shutdown mode, an 8-bit data write operation to the Time Update Register is required to restart the LED breathing effect after the IC is re-enabled.

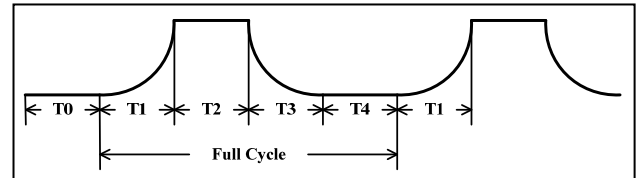

Figure 8 Breathing Timing

RGB AUTO BREATHING CONTROL WITH COLOR SETTING

IS31FL3199 can pre-establish pattern achieving mixing color breathing. There are three groups RGB. Each RGB consists of three channels. Every channel has an 8-bit PWM data register. The color can be set by the PWM data register. For example, there are three PWM data: 20h, 80h, C8h, so the three data will determine a kind of color.

After setting the color, T0~T4 time register will be set to control the LED breathing panel. And T0~T4 time should be same for one RGB or the pre-established color will change.

SEMIAUTOMATIC BREATHING

By setting the RGBx bits of the Configuration Register1 (03h) to "1" and the RM bit of the Ramping Mode Register (05h) to "1", the ramping function is enabled. HT is the time select bit. When HT bit is set to "0", T2 will be held forever, and the LED will remain at the programmed maximum intensity. When HT bit is set to "1", T3 will continue and T4 will be held, causing the LED to complete one breathing cycle and then remain off.

AUDIO MODULATE DISPLAY MODE WITH AGC FUNCTION

In audio modulate display mode the output current can be modulated by the audio input signal. An AGC automatically adjusts the audio input gain to improve the dynamic range of the LED current modulation, thus improving the visual effect. When the input signal is

IS31FL3199

large such that the amplifier output begins to clip, the gain goes down. If the input signal is small, the gain increases, adjusting the output to provide a good dynamic response to the input signal.

The AGC can be disabled and the audio gain can be set by programming Configuration Register 1 (03h).

BREATHING MARK FUNCTION

By setting the BME bit of the Breathing Mark Register (06h) to “1”, the breathing mark function is enabled. The CLK/V_{BM} pin is used as V_{BM}. If the BME bit sets to “0”, the breathing mark function disabled. The CLK/V_{BM} pin is used as CLK. V_{BM} is an output pin. The breathing mark function is useful as a signal to notify the MCU when to update the color data. At the end of time period T1, V_{BM} will induce a falling edge and hold logic low, so the new data can be sent by MCU at this time. At the end of T3, V_{BM} will induce a rising edge and the MCU can send an update command to update all data simultaneously (Figure 9). The marking channel (OUT1~OUT9) is selected by the CSS bits of the Breathing Mark Register (06h).

When IS31FL3199 operates as slave, the breathing mark function is unavailable.

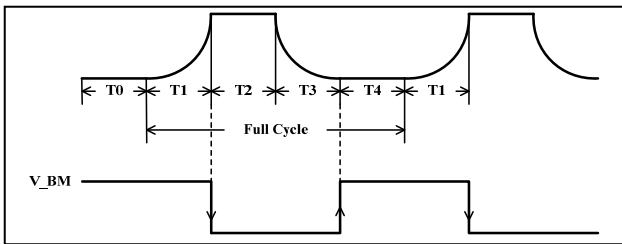

Figure 9 V_{BM} Signal

CASCADE FOR SYNCHRONIZATION OF CHIPS

Operating in the cascade mode can make two chips synchronize. By setting the CM bit of Configuration Register 2 (04h) to “0”, IS31FL3199 operates as a

master. There are two pins (CLK, I_{AUD}) for synchronization of chips. CLK pin can synchronize the breathing and I_{AUD} pin can synchronize the audio current.

SHUTDOWN MODE

Shutdown mode can either be used as a means of reducing power consumption or generating a flashing display (repeatedly entering and leaving shutdown mode). During shutdown mode all registers retain their data and can be accessed via the I2C bus interface. The only difference between Software and Hardware shutdown mode is the current consumption.

Software Shutdown

By setting SSD bit of the Shutdown Register (00h) to “0”, the IS31FL3199 will operate in software shutdown mode, wherein it consumes only 2μA (Typ.) current. When the IS31FL3199 is in software shutdown mode, all current sources are switched off.

Hardware Shutdown

The chip enters hardware shutdown mode when the SDB pin is pulled low, wherein it consumes only 1μA (Typ.) current. When the IS31FL3199 is in hardware shutdown mode, all current sources are switched off.

Register Access During Shutdown

All registers are accessible (read or write) while the IS31FL3199 is in either Software or Hardware shutdown. SDB turn on time is about 200μs, do not send I2C commands during a rising edge of the SDB pin as data will be corrupted. Data transfers during SDB falling edge, low or high steady state are permitted.

IS31FL3199

CLASSIFICATION REFLOW PROFILES

| Profile Feature | Pb-Free Assembly |
|--|----------------------------------|
| Preheat & Soak Temperature min (T _{smin}) Temperature max (T _{smax}) Time (T _{smin} to T _{smax}) (t _s) | 150°C 200°C 60-120 seconds |
| Average ramp-up rate (T _{smax} to T _p) | 3°C/second max. |
| Liquidous temperature (T _L) Time at liquidous (t _L) | 217°C 60-150 seconds |
| Peak package body temperature (T _p)* | Max 260°C |
| Time (t _p)** within 5°C of the specified classification temperature (T _c) | Max 30 seconds |
| Average ramp-down rate (T _p to T _{smax}) | 6°C/second max. |
| Time 25°C to peak temperature | 8 minutes max. |

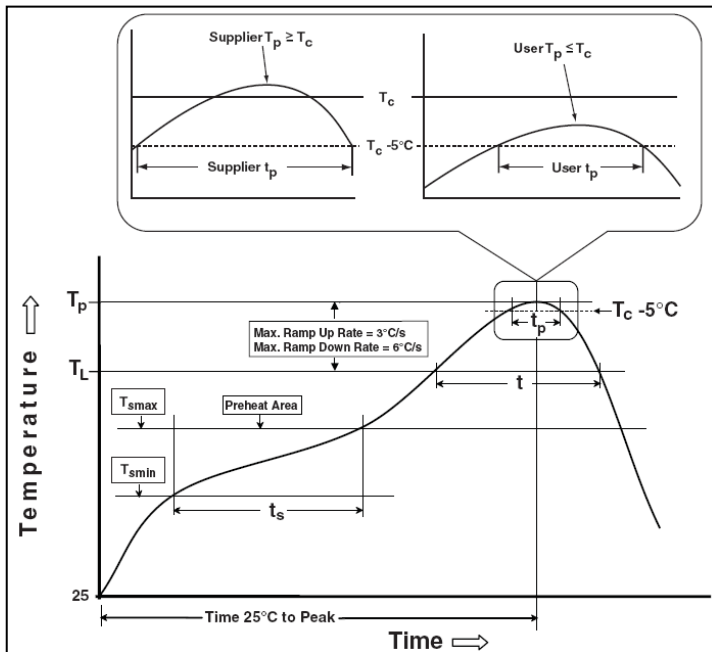
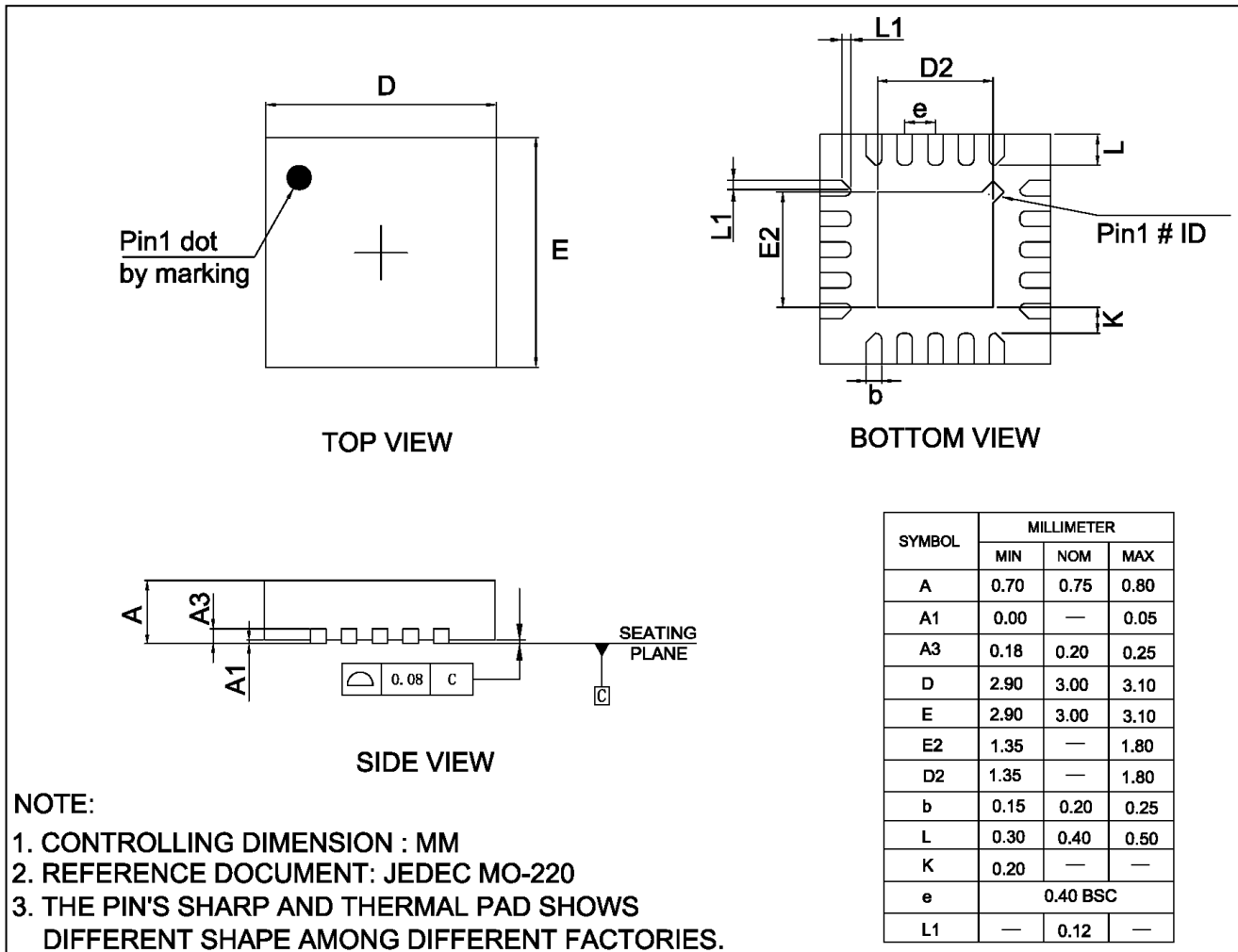

Figure 10 Classification Profile

IS31FL3199

PACKAGE INFORMATION

QFN-20



IS31FL3199

RECOMMENDED LAND PATTERN

QFN-20

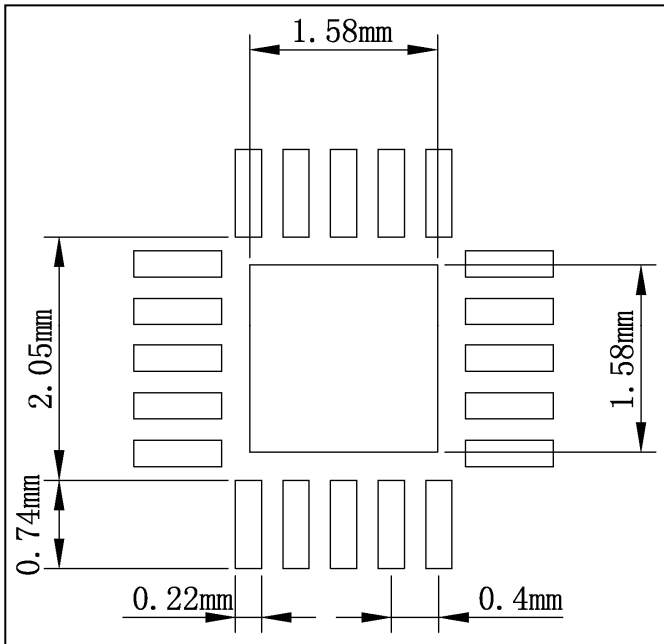

Note:

1. Land pattern complies to IPC-7351.
2. All dimensions in MM.
3. This document (including dimensions, notes & specs) is a recommendation based on typical circuit board manufacturing parameters. Since land pattern design depends on many factors unknown (eg. user's board manufacturing specs), user must determine suitability for use.

REVISION HISTORY

| Revision | Detail Information | Date |
|----------|---|------------|
| A | Initial release | 2011.12.26 |
| B | Add ESD(HBM/CDM) value | 2013.12.25 |
| C | <ol style="list-style-type: none">1. Update θ_{JA} value2. Update I_{IH}/I_{IIL} test condition3. V_{IH}, V_{IIL} condition revise to V_{CC}= 2.7V~5.5V4. Add STANDARD MODE in DIGITAL INPUT SWITCHING CHARACTERISTICS5. Add function block diagram6. Add POWER ON SEQUENCE section in APPLICATION INFORMATION7. Update POD8. Add land pattern | 2018.10.15 |

Looking for pricing, stock, or lifecycle information?

Click below to explore more details on WIN SOURCE:

- [View IS31FL3199-QFLS2-TR on WIN SOURCE](#)
- [Lumissil Microsystems Information](#)

Optimize Your Supply Chain with WIN SOURCE Solutions

- ✓ Global Sourcing Solution
- ✓ Obsolete Management
- ✓ Cost Control Management
- ✓ Shortage Management
- ✓ Alternative Solution
- ✓ Excess Inventory Management