



**THE DATASHEET OF
IRS25091STRPBF**



HALF-BRIDGE DRIVER

Features

- 600V half-bridge driver
- Tolerant to negative transient voltages
- Gate drive supply range from 10 V to 20 V
- Under-voltage lock-out for both channels
- 3.3 V, 5 V and 15 V input logic compatible
- Cross-conduction prevention logic
- Matched propagation delay for both channels
- High side output in phase with IN input
- Internal 530 ns dead-time, and programmable up to 5usec with external resistor.
- Lower di/dt gate driver for better noise immunity
- DT/SD input turns off both channels
- RoHS compliant

Packages



Product Summary

V_{OFFSET}	600 V max.
$I_{\text{O}+/-}$	120 mA / 250 mA
V_{OUT}	10 V – 20 V
$t_{\text{on/off (typ.)}}$	750 ns & 200 ns
Dead Time	530 ns

Description

The IRS25091 is a high-voltage, high-speed power MOSFET and IGBT half-bridge driver with independent high and low side referenced output channels. Proprietary HVIC and latch immune CMOS technologies enable a ruggedized monolithic construction. The logic input is compatible with standard CMOS or LSTTL output, down to 3.3 V. The output drivers feature a high pulse current buffer stage designed for minimum driver cross-conduction. The floating channel can be used to drive an N-channel power MOSFET or IGBT in the high side configuration which operates up to 600V.

Applications:

*HID Electronic Ballasts

Typical Connection

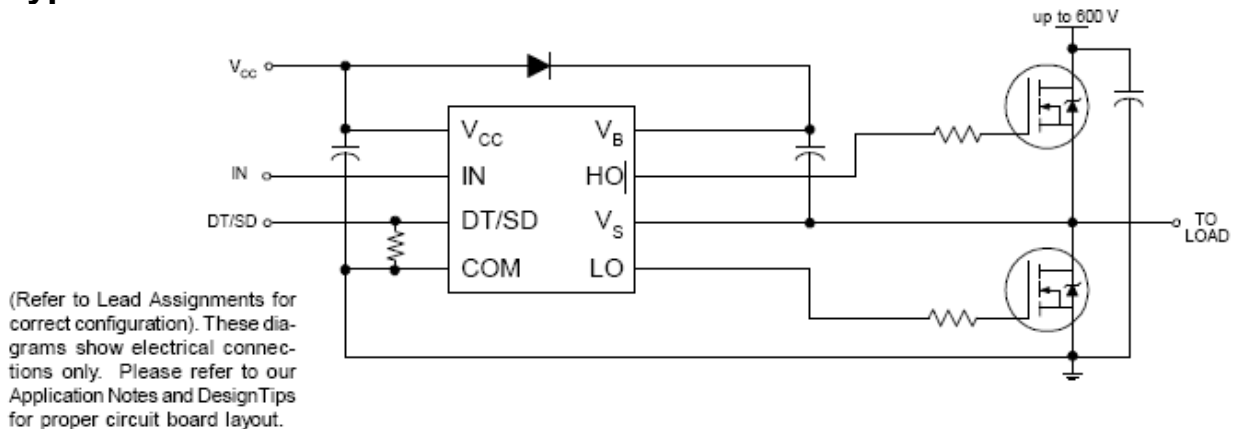

Qualification Information[†]

Qualification Level		Industrial ^{††} (per JEDEC JESD 47)	
		Comments: This IC has passed JEDEC's Industrial qualification. IR's Consumer qualification level is granted by extension of the higher Industrial level.	
Moisture Sensitivity Level		SOIC-8N	MSL2 ^{†††} (per IPC/JEDEC J-STD-020)
ESD	Machine Model	Class B (+/-200V) (per JEDEC standard JESD22-A115)	
	Human Body Model	Class 1C (+/-1000V) (per EIA/JEDEC standard EIA/JESD22-A114)	
IC Latch-Up Test		Class I, Level A (per JESD78A)	
RoHS Compliant		Yes	

† Qualification standards can be found at International Rectifier's web site <http://www.irf.com/>

†† Higher qualification ratings may be available should the user have such requirements. Please contact your International Rectifier sales representative for further information.

††† Higher MSL ratings may be available for the specific package types listed here. Please contact your International Rectifier sales representative for further information.

Absolute Maximum Ratings

Absolute Maximum Ratings indicate sustained limits beyond which damage to the device may occur. All voltage parameters are absolute voltages referenced to COM. The thermal resistance and power dissipation ratings are measured under board mounted and still air conditions.

Symbol	Definition	Min.	Max.	Units
V _B	High side floating absolute voltage	-0.3	620	V
V _S	High side floating supply offset voltage	V _B - 20	V _B + 0.3	
V _{HO}	High side floating output voltage	V _S - 0.3	V _B + 0.3	
V _{CC}	Low side and logic fixed supply voltage	-0.3	20	
V _{LO}	Low side output voltage	-0.3	V _{CC} + 0.3	
V _{IN}	Logic input voltage	COM -0.3	V _{CC} + 0.3	
V _{DT/SD}	Programmable deadtime and shutdown input voltage	COM -0.3	V _{CC} + 0.3	
COM	Logic ground	V _{CC} - 20	V _{CC} + 0.3	
dV _S /dt	Allowable offset supply voltage transient	—	50	V/ns
P _D	Package power dissipation @ TA ≤ +25 °C	—	0.625	W
R _{thJA}	Thermal resistance, junction to ambient	—	200	°C/W
T _J	Junction temperature	—	150	°C
T _S	Storage temperature	-50	150	
T _L	Lead temperature (soldering, 10 seconds)	—	300	

Recommended Operating Conditions

For proper operation the device should be used within the recommended conditions. The V_S and COM offset rating are tested with all supplies biased at 15 V differential.

Symbol	Definition	Min.	Max.	Units
V _B	High side floating supply absolute voltage	V _S +10	V _S +20	V
V _S	Static High side floating supply offset voltage	COM- 8(Note 1)	600	
V _{St}	Transient High side floating supply offset voltage	-50 (Note2)	600	
V _{HO}	High side floating output voltage	V _S	V _B	
V _{CC}	Low side and logic fixed supply voltage	10	20	
V _{LO}	Low side output voltage	0	V _{CC}	
V _{IN}	Logic input voltage (IN & DT/SD)	V _{SS}	V _{CC}	
V _{DT/SD}	Programmable dead-time and shutdown input voltage	V _{SS}	V _{CC}	
T _A	Ambient temperature	-40	125	°C

Note 1: Logic operational for V_S of -8 V to +600 V. Logic state held for V_S of -8 V to -V_{BS}.

Note 2: Operational for transient negative V_S of COM - 50 V with a 50 ns pulse width. Guaranteed by design. Refer to the Application Information section of this datasheet for more details.

Dynamic Electrical Characteristics

V_{BIAS} (V_{CC} , V_{BS}) = 15 V, COM = V_{CC} , C_L = 1000 pF, T_A = 25 °C, DT = V_{SS} unless otherwise specified.

Symbol	Definition	Min	Typ	Max	Units	Test Conditions
t_{on}	Turn-on propagation delay	—	750	1100	ns	$V_S = 0$ V or 600 V
t_{off}	Turn-off propagation delay	—	250	400		$V_S = 0$ V or 600 V
t_{sd}	Shut-down propagation delay	—	250	400		
MT	Delay matching, HS & LS turn-on/off	—	—	60		
t_r	Turn-on rise time	—	150	220		$V_S = 0$ V
t_f	Turn-off fall time	—	50	80		$V_S = 0$ V
DT	Deadtime: LO turn-off to HO turn-on(DT _{LO-HO}) & HO turn-off to LO turn-on (DT _{HO-LO})	350	530	800		
		3	4.5	6	us	RDT = 200K ohms
MDT	Deadtime matching = DT _{LO-HO} - DT _{HO-LO}	—	—	60	ns	RDT = 0 ohms
		—	—	1100		RDT = 200K ohms

Static Electrical Characteristics

V_{BIAS} (V_{CC} , V_{BS}) = 15 V, V_{CC} = COM and T_A = 25 °C unless otherwise specified. The V_{IL} , V_{IH} and I_{IN} parameters are referenced to V_{CC}/COM and are applicable to the respective input leads: IN and DT/SD. The V_O , I_O parameters are referenced to COM and are applicable to the respective output leads: HO and LO.

Symbol	Definition	Min	Typ	Max	Units	Test Conditions
V_{IH}	logic "1" input voltage for HO & logic "0" for LO	2.2	—	—	V	
V_{IL}	logic "0" input voltage for HO & logic "1" for LO	—	—	0.8		
V_{OH}	High level output voltage, $V_{BIAS} - V_O$	—	0.8	1.4		$I_O = 20$ mA
V_{OL}	Low level output voltage, V_O	—	0.3	0.6		$I_O = 20$ mA
I_{LK}	Offset supply leakage current	—	—	50	μ A	$V_B = V_S = 600$ V
I_{QBS}	Quiescent V_{BS} supply current	—	45	70		$V_{IN} = 0$ V or 4 V
I_{QCC}	Quiescent V_{CC} supply current	1000	2000	3000		$V_{IN} = 0$ V or 4 V
I_{IN+}	Logic "1" input bias current	—	5	20		$V_{IN} = 4$ V
I_{IN-}	Logic "0" input bias current	—	—	2	$V_{IN} = 0$ V	
$I_{SD, TH}$	DT/SD input threshold	11.5	13	14.5	V	
V_{CCUV+} V_{BSUV+}	V_{CC} and V_{BS} supply undervoltage positive going Threshold	8.0	8.9	9.8		
V_{CCUV-} V_{BSUV-}	V_{CC} and V_{BS} supply undervoltage negative going Threshold	7.4	8.2	9.0		
V_{CCUVH} V_{BSUVH}	Hysteresis	—	0.7	—		
I_{O+}	Output high short circuit pulsed current	120	200	—	mA	$V_O = 0$ V, PW ≤ 10 us
I_{O-}	Output low short circuit pulsed current	250	350	—		$V_O = 15$ V, PW ≤ 10 us

Functional Block Diagrams

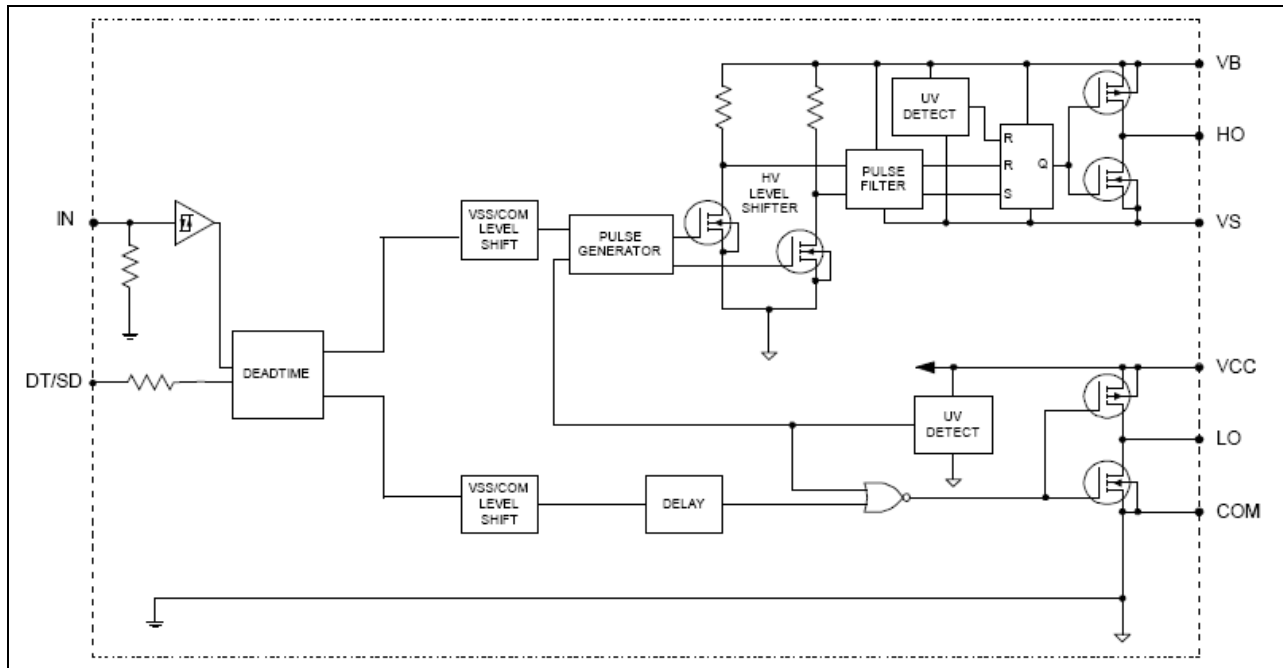

Lead Definitions

Symbol	Description
IN	Logic input for high and low side gate driver outputs (HO and LO), in phase with HO
DT/SD	Programmable deadtime, disables input/output logic when tied to VCC
V _B	High side floating supply
HO	High side gate drive output
V _S	High side floating supply return
V _{CC}	Low side and logic fixed supply
LO	Low side gate drive output
COM	Low side return

Lead Assignments

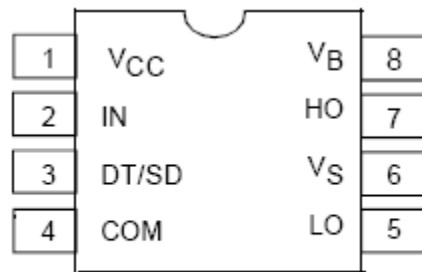

8 Lead SOIC

Application Information and Additional Details

Informations regarding the following topics are included as subsections within this section of the datasheet.

- IGBT/MOSFET Gate Drive
- Switching and Timing Relationships
- Deadtime
- Matched Propagation Delays
- Shut down Input
- Input Logic Compatibility
- Undervoltage Lockout Protection
- Shoot-Through Protection
- Negative V_S Transient SOA
- PCB Layout Tips
- Additional Documentation

IGBT/MOSFET Gate Drive

The IRS25091 HVIC is designed to drive MOSFET or IGBT power devices. Figures 1 and 2 illustrate several parameters associated with the gate drive functionality of the HVIC. The output current of the HVIC, used to drive the gate of the power switch, is defined as I_O . The voltage that drives the gate of the external power switch is defined as V_{HO} for the high-side power switch and V_{LO} for the low-side power switch; this parameter is sometimes generically called V_{OUT} and in this case does not differentiate between the high-side or low-side output voltage.

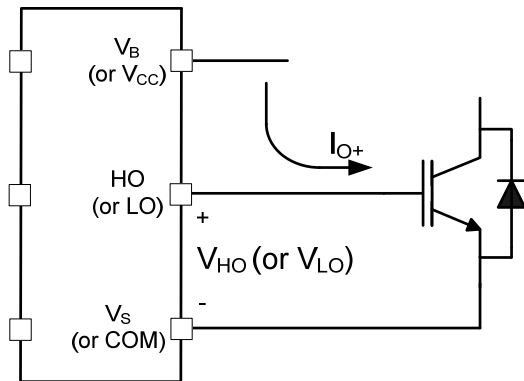

Figure 1: HVIC sourcing current

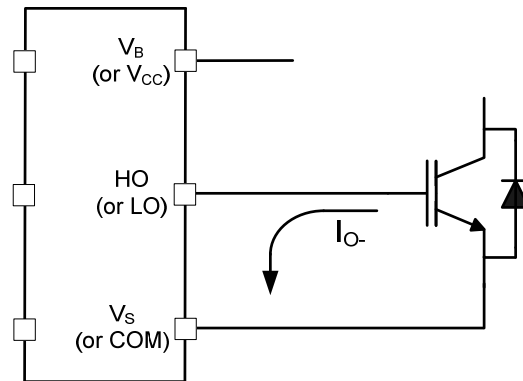

Figure 2: HVIC sinking current

Shut down Input

The IRS25091 is equipped with a shut down (DT/SD) input pin that is used to shutdown or enable the HVIC. When the DT/SD pin is in the low state the HVIC is able to operate normally. When the DT/SD pin is in the high state the HVIC is tri-stated.

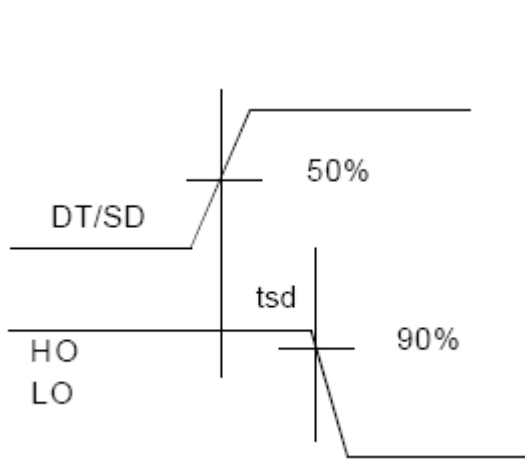

Figure 5: Shut down

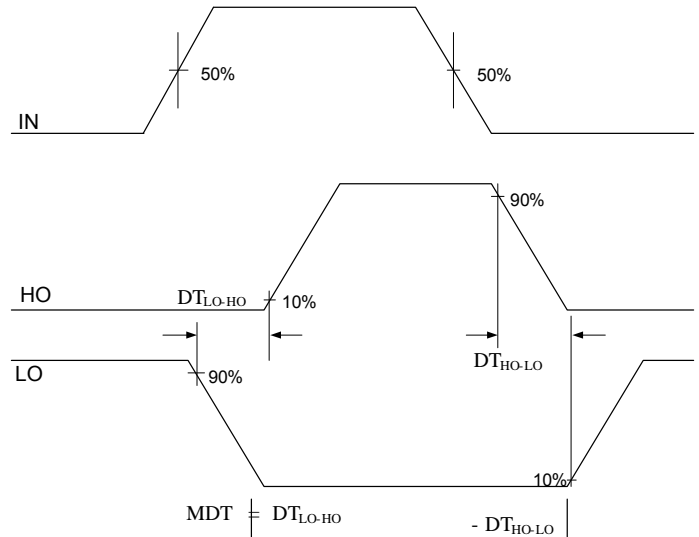

Figure 6: Dead time Definition

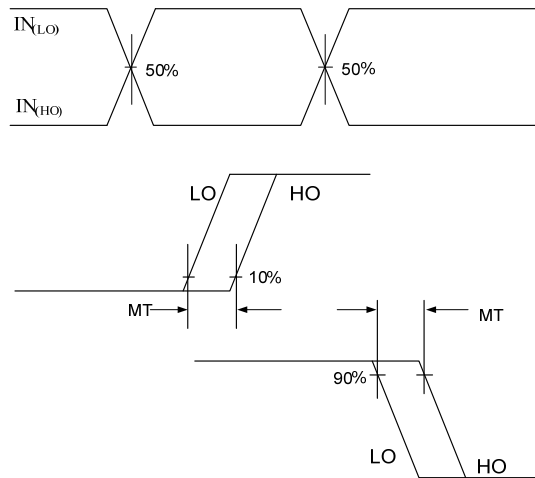

Figure 7: Delay Matching waveform Definition

Input Logic Compatibility

The inputs of this IC are compatible with standard CMOS and TTL outputs. The IRS25091 has been designed to be compatible with 3.3 V and 5 V logic-level signals. Figure 8 illustrates an input signal to the IRS25091, its input threshold values, and the logic state of the IC as a result of the input signal.

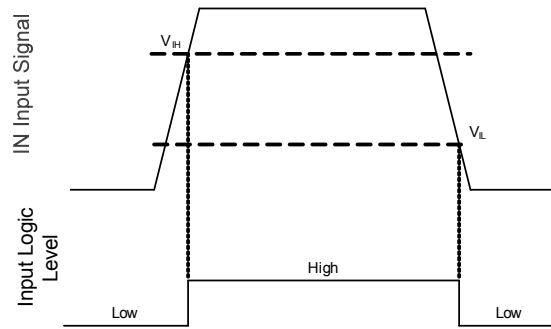

Figure 8: HIN & LIN input thresholds

Undervoltage Lockout Protection

This family of ICs provides undervoltage lockout protection on both the V_{CC} (logic and low-side circuitry) power supply and the V_{BS} (high-side circuitry) power supply. Figure 9 is used to illustrate this concept; V_{CC} (or V_{BS}) is plotted over time and as the waveform crosses the UVLO threshold ($V_{CCUV+/-}$ or $V_{BSUV+/-}$) the undervoltage protection is enabled or disabled.

Upon power-up, should the V_{CC} voltage fail to reach the V_{CCUV+} threshold, the IC will not turn-on. Additionally, if the V_{CC} voltage decreases below the V_{CCUV-} threshold during operation, the undervoltage lockout circuitry will recognize a fault condition and shutdown the high- and low-side gate drive outputs, and the FAULT pin will transition to the low state to inform the controller of the fault condition.

Upon power-up, should the V_{BS} voltage fail to reach the V_{BSUV} threshold, the IC will not turn-on. Additionally, if the V_{BS} voltage decreases below the V_{BSUV} threshold during operation, the undervoltage lockout circuitry will recognize a fault condition, and shutdown the high-side gate drive outputs of the IC.

The UVLO protection ensures that the IC drives the external power devices only when the gate supply voltage is sufficient to fully enhance the power devices. Without this feature, the gates of the external power switch could be driven with a low voltage, resulting in the power switch conducting current while the channel impedance is high; this could result in very high conduction losses within the power device and could lead to power device failure.

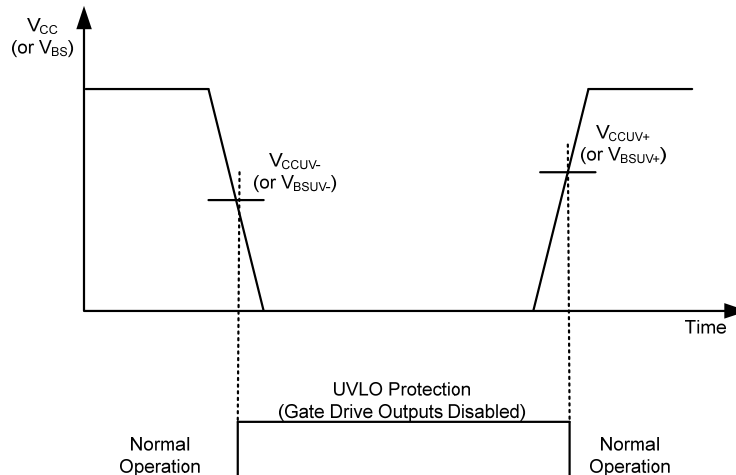

Figure 9: UVLO protection

Shoot-Through Protection

The IRS25091 high-voltage IC is equipped with shoot-through protection circuitry (also known as cross-conduction prevention circuitry).

Negative V_s Transient SOA

A common problem in today's high-power switching converters is the transient response of the switch node's voltage as the power switches transition on and off quickly while carrying a large current. A typical 3-phase inverter circuit is shown in Figure 11; here we define the power switches and diodes of the inverter.

If the high-side switch (e.g., the IGBT Q1 in Figures 12 and 13) switches off, while the U phase current is flowing to an inductive load, a current commutation occurs from high-side switch (Q1) to the diode (D2) in parallel with the low-side switch of the same inverter leg. At the same instance, the voltage node V_{s1} , swings from the positive DC bus voltage to the negative DC bus voltage.

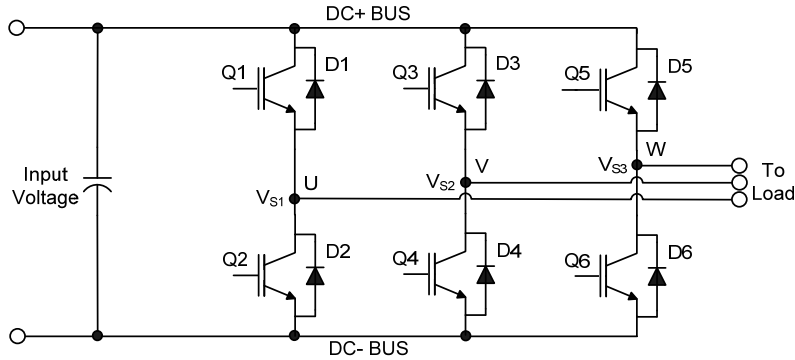

Figure 11: Three phase inverter

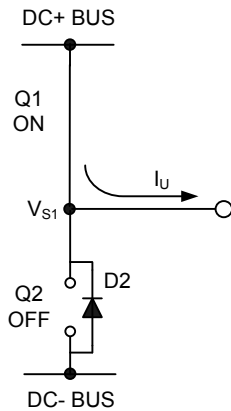

Figure 12: Q1 conducting

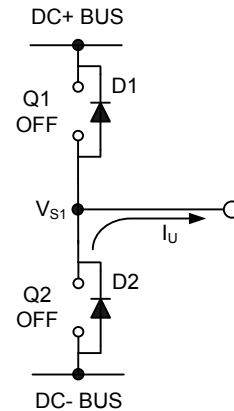

Figure 13: D2 conducting

Also when the V phase current flows from the inductive load back to the inverter (see Figures 14 and 15), and Q4 IGBT switches on, the current commutation occurs from D3 to Q4. At the same instance, the voltage node, V_{s2} , swings from the positive DC bus voltage to the negative DC bus voltage.

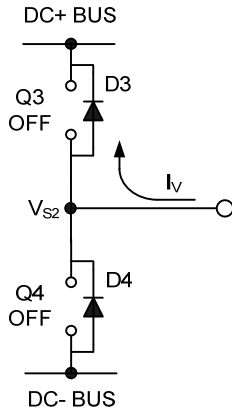

Figure 14: D3 conducting

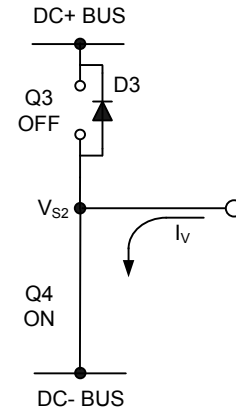

Figure 15: Q4 conducting

However, in a real inverter circuit, the V_S voltage swing does not stop at the level of the negative DC bus, rather it swings below the level of the negative DC bus. This undershoot voltage is called “negative V_S transient”.

The circuit shown in Figure 16 depicts one leg of the three phase inverter; Figures 17 and 18 show a simplified illustration of the commutation of the current between Q1 and D2. The parasitic inductances in the power circuit from the die bonding to the PCB tracks are lumped together in L_C and L_E for each IGBT. When the high-side switch is on, V_{S1} is below the DC+ voltage by the voltage drops associated with the power switch and the parasitic elements of the circuit. When the high-side power switch turns off, the load current momentarily flows in the low-side freewheeling diode due to the inductive load connected to V_{S1} (the load is not shown in these figures). This current flows from the DC- bus (which is connected to the COM pin of the HVIC) to the load and a negative voltage between V_{S1} and the DC- Bus is induced (i.e., the COM pin of the HVIC is at a higher potential than the V_S pin).

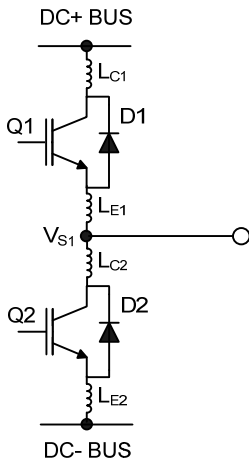

Figure 16: Parasitic Elements

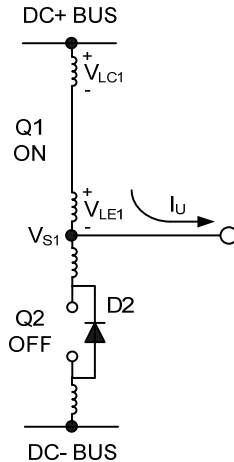

Figure 17: V_S positive

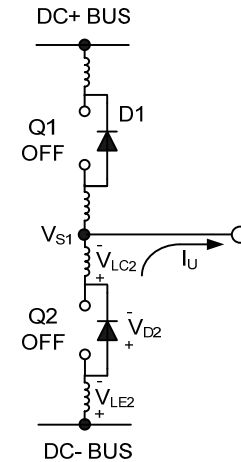

Figure 18: V_S negative

In a typical motor drive system, dV/dt is typically designed to be in the range of 3-5 V/ns. The negative V_S transient voltage can exceed this range during some events such as short circuit and over-current shutdown, when di/dt is greater than in normal operation.

International Rectifier’s HVICs have been designed for the robustness required in many of today’s demanding applications. An indication of the IRS25091’s robustness can be seen in Figure 19, where there is represented the IRS25091 Safe Operating Area at $V_{BS}=15V$ based on repetitive negative V_S spikes. A negative V_S transient voltage falling in the grey area (outside SOA) may lead to IC permanent damage; viceversa unwanted functional anomalies or permanent damage to the IC do not appear if negative V_S transients fall inside SOA.

At $V_{BS}=15V$ in case of $-V_S$ transients greater than $-16.5 V$ for a period of time greater than 50 ns; the HVIC will hold by design the high-side outputs in the off state for 4.5 μs .

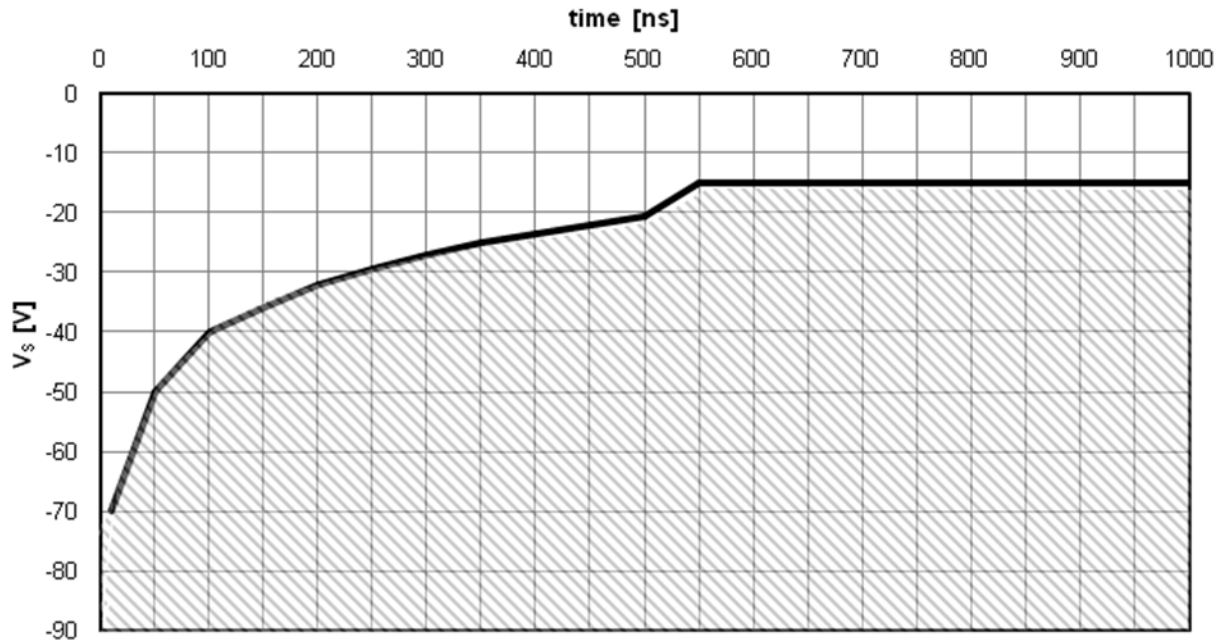

Figure 19: Negative V_S transient SOA for IRS25091 @ $V_{BS}=15V$

Even though the IRS25091 has been shown able to handle these large negative V_S transient conditions, it is highly recommended that the circuit designer always limit the negative V_S transients as much as possible by careful PCB layout and component use.

PCB Layout Tips

Distance between high and low voltage components: It's strongly recommended to place the components tied to the floating voltage pins (V_B and V_S) near the respective high voltage portions of the device. Please see the Case Outline information in this datasheet for the details.

Ground Plane: In order to minimize noise coupling, the ground plane should not be placed under or near the high voltage floating side.

Gate Drive Loops: Current loops behave like antennas and are able to receive and transmit EM noise (see Figure 20). In order to reduce the EM coupling and improve the power switch turn on/off performance, the gate drive loops must be reduced as much as possible. Moreover, current can be injected inside the gate drive loop via the IGBT collector-to-gate parasitic capacitance. The parasitic auto-inductance of the gate loop contributes to developing a voltage across the gate-emitter, thus increasing the possibility of a self turn-on effect.

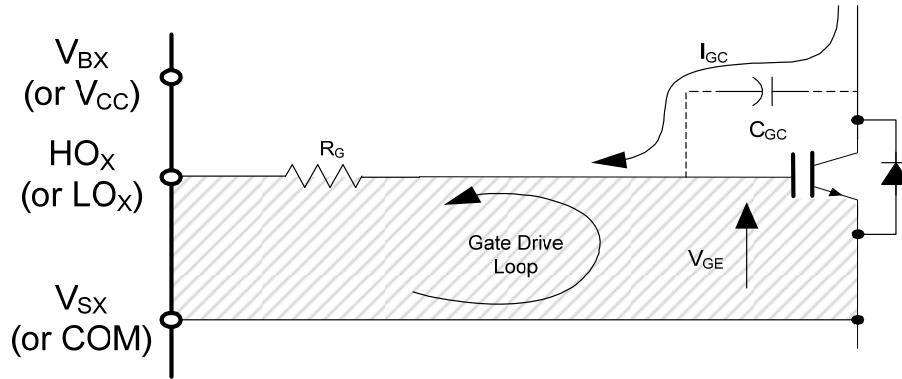

Figure 20: Antenna Loops

Supply Capacitor: It is recommended to place a bypass capacitor (C_{IN}) between the V_{CC} and COM pins. A ceramic $1\ \mu\text{F}$ ceramic capacitor is suitable for most applications. This component should be placed as close as possible to the pins in order to reduce parasitic elements.

Routing and Placement: Power stage PCB parasitic elements can contribute to large negative voltage transients at the switch node; it is recommended to limit the phase voltage negative transients. In order to avoid such conditions, it is recommended to 1) minimize the high-side emitter to low-side collector distance, and 2) minimize the low-side emitter to negative bus rail stray inductance. However, where negative V_S spikes remain excessive, further steps may be taken to reduce the spike. This includes placing a resistor ($5\ \Omega$ or less) between the V_S pin and the switch node (see Figure 21), and in some cases using a clamping diode between COM and V_S (see Figure 22). See DT04-4 at www.irf.com for more detailed information.

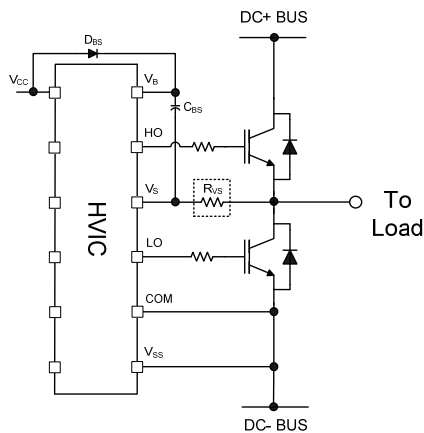

Figure 21: V_S resistor

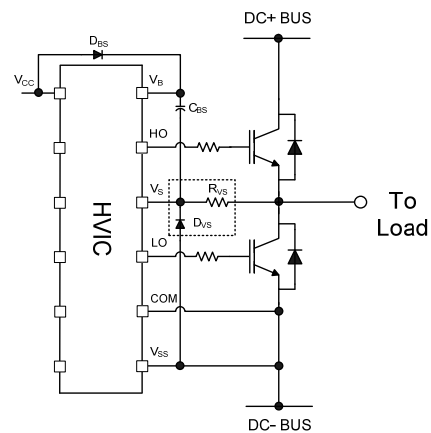

Figure 22: V_S clamping diode

Additional Documentation

Several technical documents related to the use of HVICs are available at www.irf.com; use the Site Search function and the document number to quickly locate them. Below is a short list of some of these documents.

- DT97-3: Managing Transients in Control IC Driven Power Stages
- AN-1123: Bootstrap Network Analysis: Focusing on the Integrated Bootstrap Functionality
- DT04-4: Using Monolithic High Voltage Gate Drivers
- AN-978: HV Floating MOS-Gate Driver ICs

Figures 23-46 provide information on the experimental performance of the IRS25091 HVIC. The line plotted in each figure is generated from actual lab data. A large number of individual samples from multiple wafer lots were tested at three temperatures (-40 °C, 25 °C, and 125 °C) in order to generate the experimental (Exp.) curve. The line labeled Exp. consist of three data points (one data point at each of the tested temperatures) that have been connected together to illustrate the understood trend. The individual data points on the curve were determined by calculating the averaged experimental value of the parameter (for a given temperature).

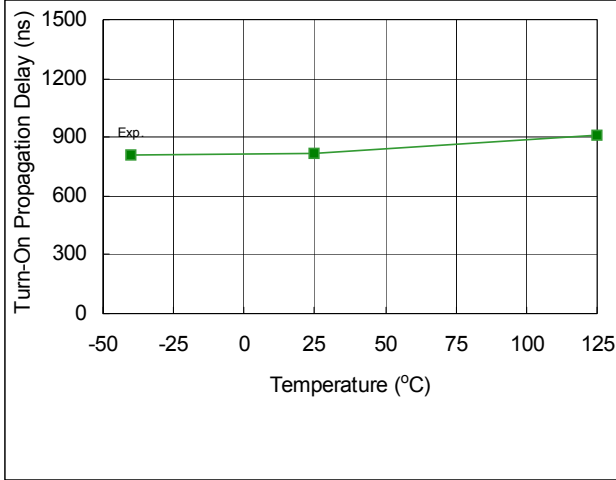

Fig. 23. Turn-on Propagation Delay vs. Temperature

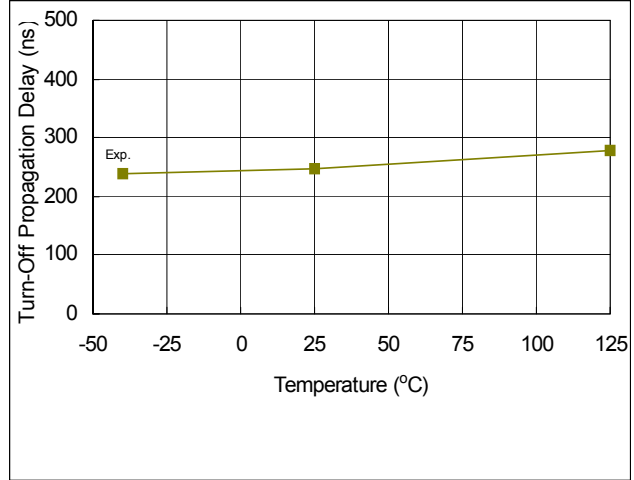

Fig. 24. Turn-off Propagation Delay vs. Temperature

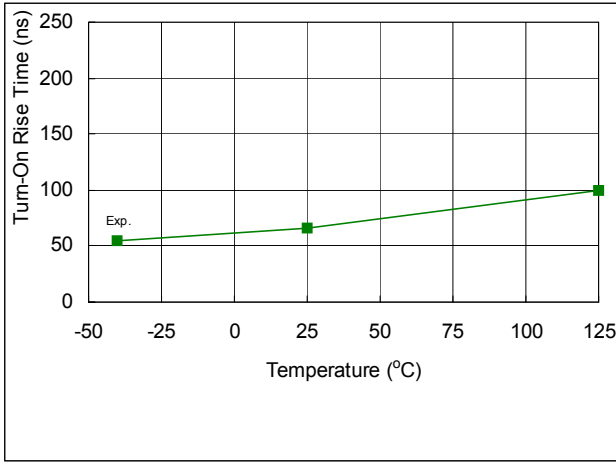

Fig. 25. Turn-on Rise Time vs. Temperature

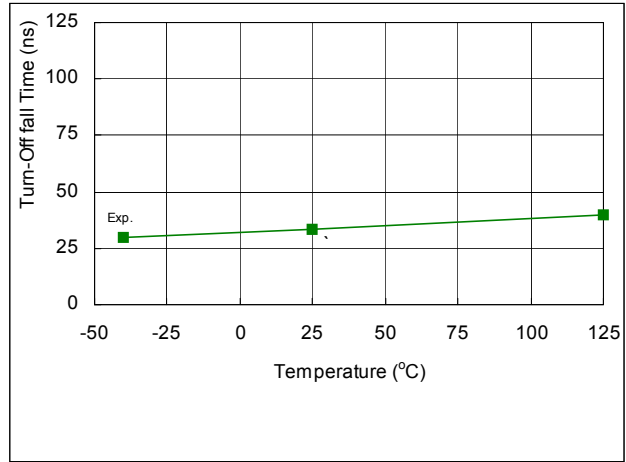

Fig. 26. Turn-off Rise Time vs. Temperature

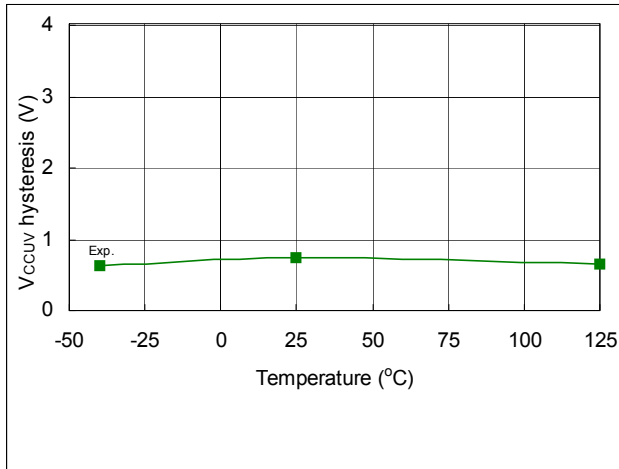

Fig. 27. V_{CC} Supply UV Hysteresis vs. Temperature

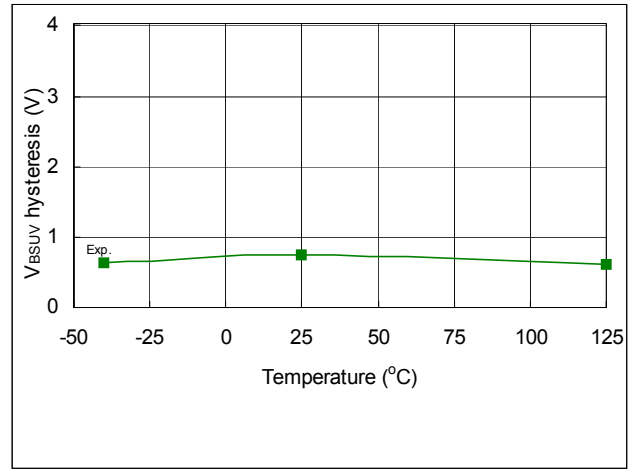

Fig. 28. V_{BS} Supply UV Hysteresis vs. Temperature

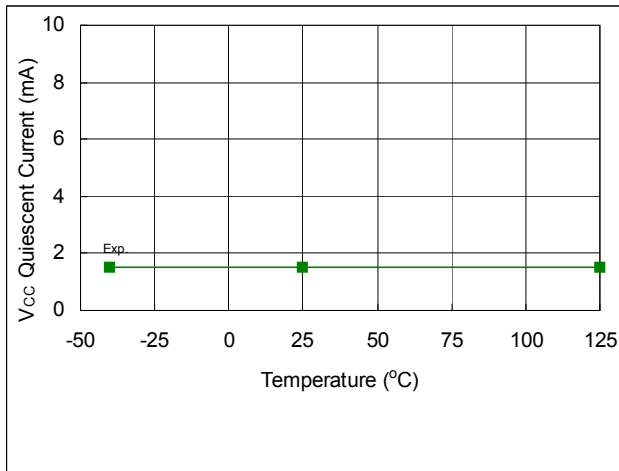

Fig. 29. V_{CC} Quiescent Supply Current vs. Temperature

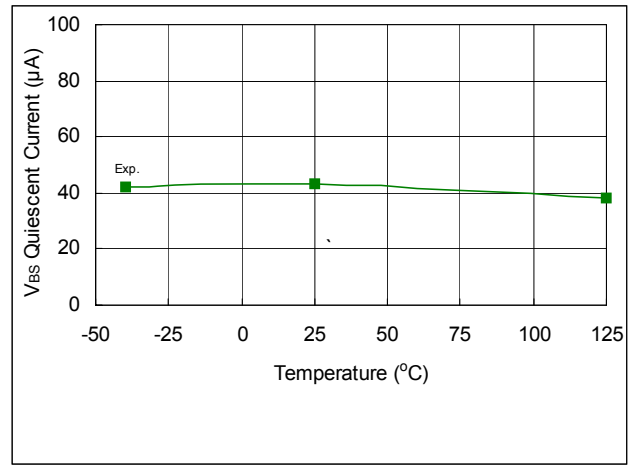

Fig. 30. V_{BS} Quiescent Supply Current vs. Temperature

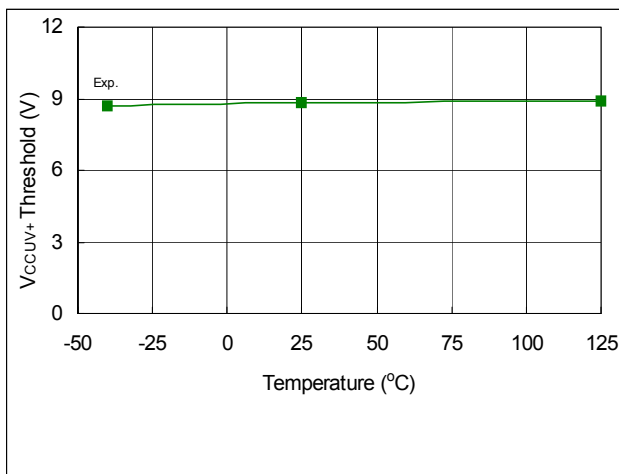

Fig. 31. V_{CCUV+} Threshold vs. Temperature

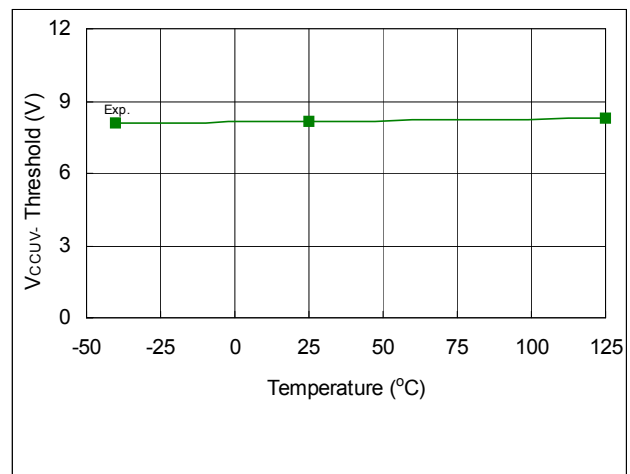

Fig. 32. V_{CCUV-} Threshold vs. Temperature

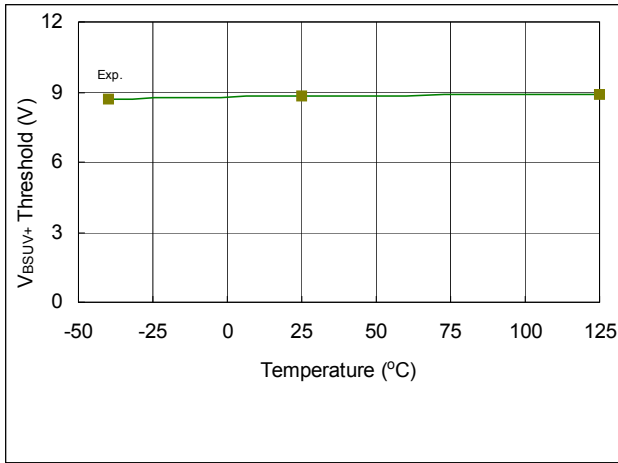

Fig. 33. V_{BSUV+} Threshold vs. Temperature

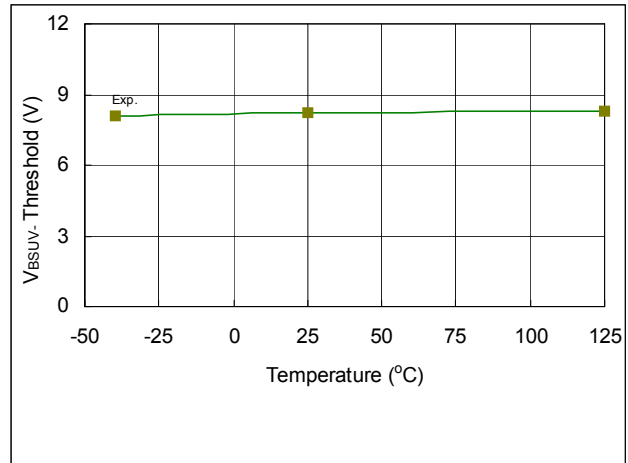

Fig. 34. V_{BSUV-} Threshold vs. Temperature

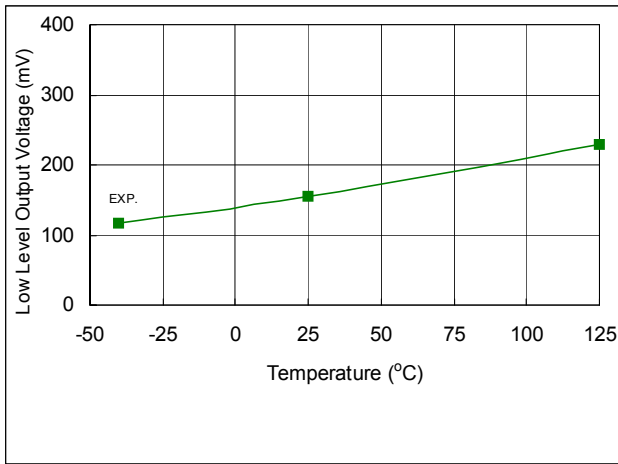

Fig. 35. Low Level Output Voltage vs. Temperature

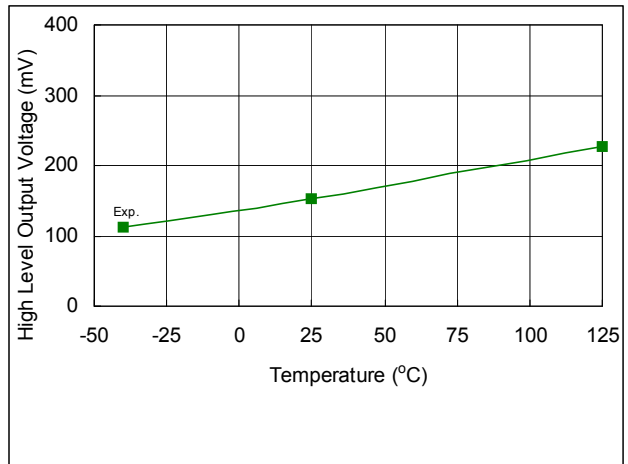

Fig. 36. High Level Output Voltage vs. Temperature

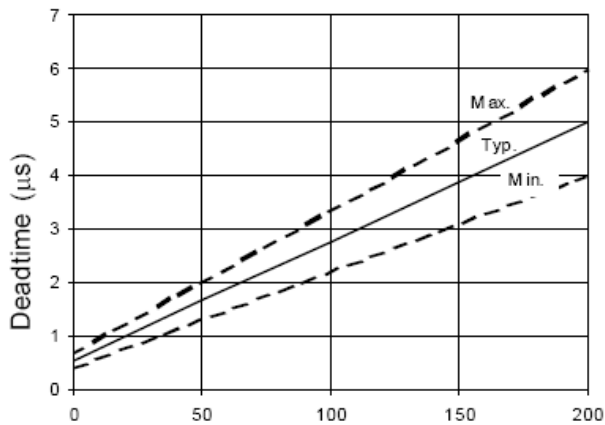

Fig. 37. Dead-time vs. RDT

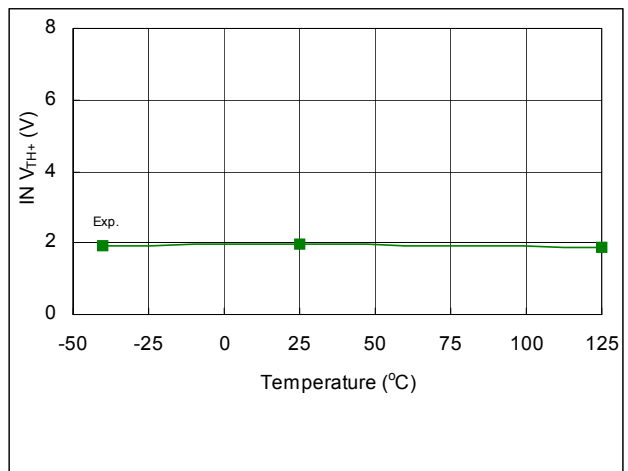

Fig. 38. IN V_{TH+} vs. Temperature

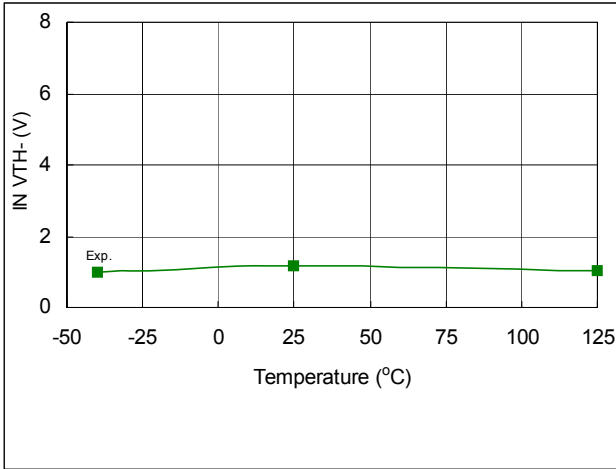

Fig. 39. LIN V_{TH-} vs. Temperature

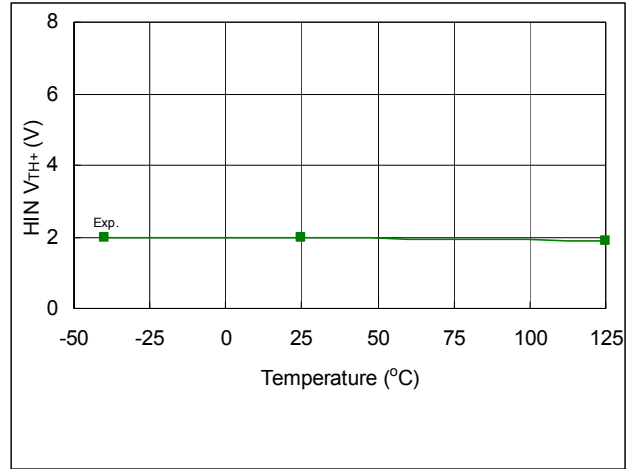

Fig. 40. HIN V_{TH+} vs. Temperature

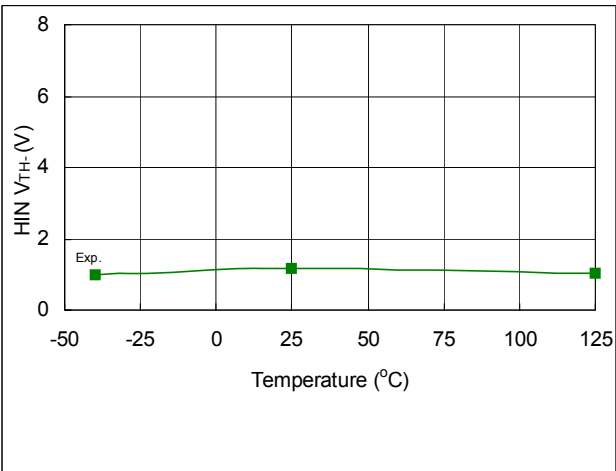

Fig. 41. HIN V_{TH-} vs. Temperature

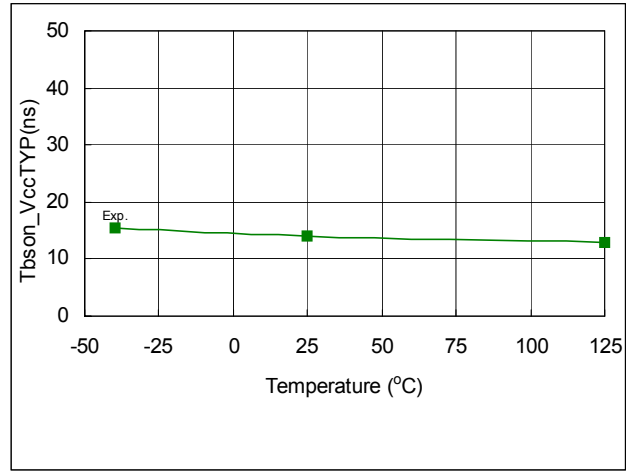

Fig. 42. T_{bson_VccTYP} vs. Temperature

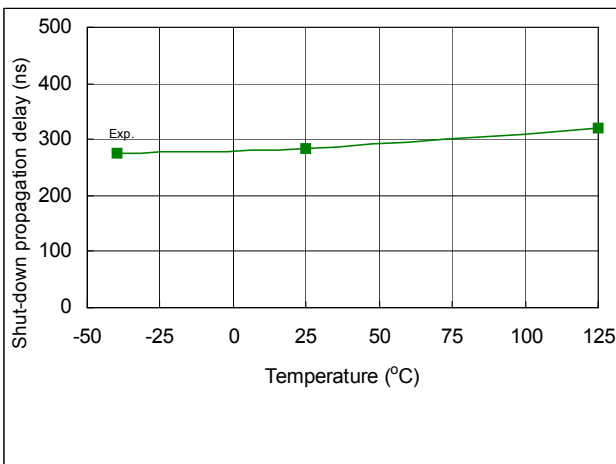

Fig. 43. Shut-down Propagation Delay vs. Temperature

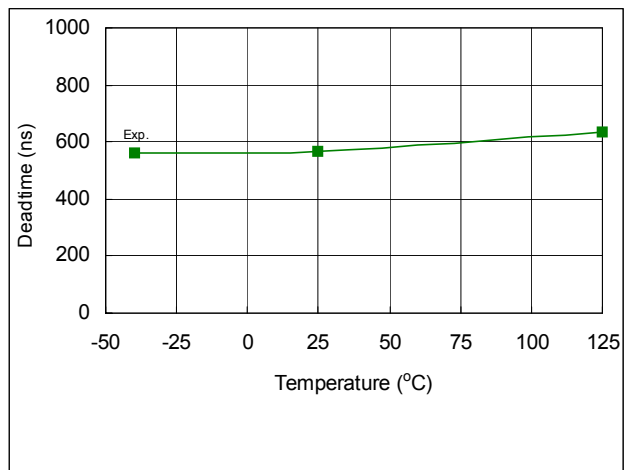

Fig. 44. Deadtime vs. Temperature

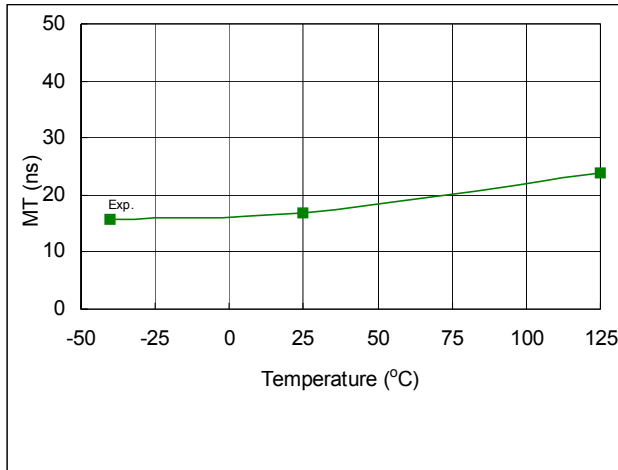

Fig. 45. Delay Matching vs. Temperature

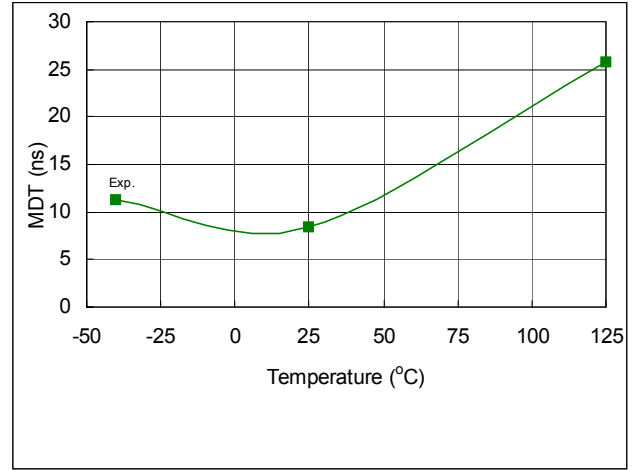
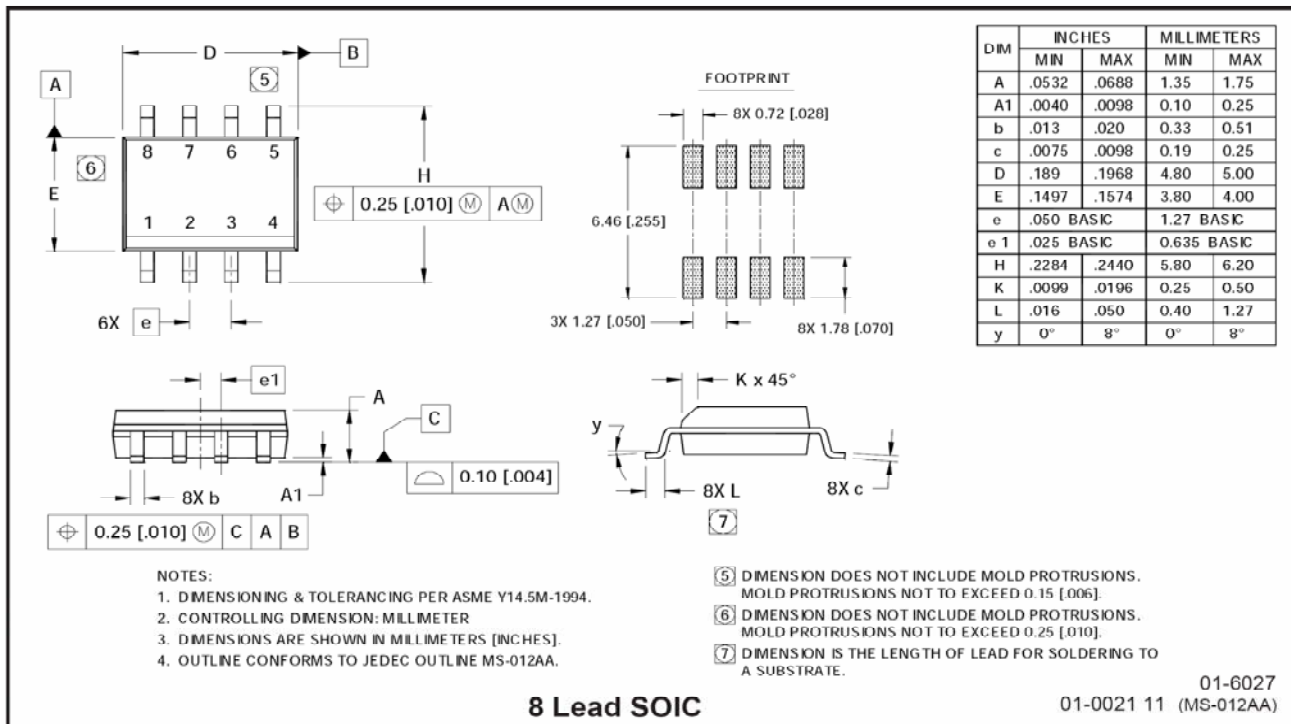
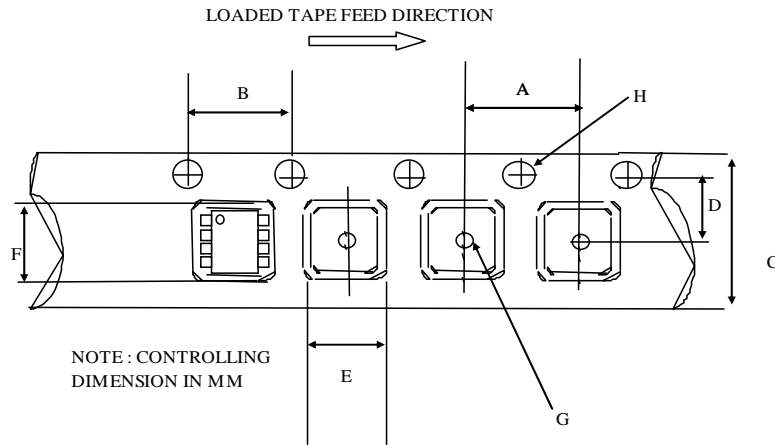

Fig. 46. Deadtime Matching vs. Temperature

Case Outlines



Tape and Reel Details: 8L-SOIC



CARRIER TAPE DIMENSION FOR 8SOICN

Code	Metric		Imperial	
	Min	Max	Min	Max
A	7.90	8.10	0.311	0.318
B	3.90	4.10	0.153	0.161
C	11.70	12.30	0.46	0.484
D	5.45	5.55	0.214	0.218
E	6.30	6.50	0.248	0.255
F	5.10	5.30	0.200	0.208
G	1.50	n/a	0.059	n/a
H	1.50	1.60	0.059	0.062

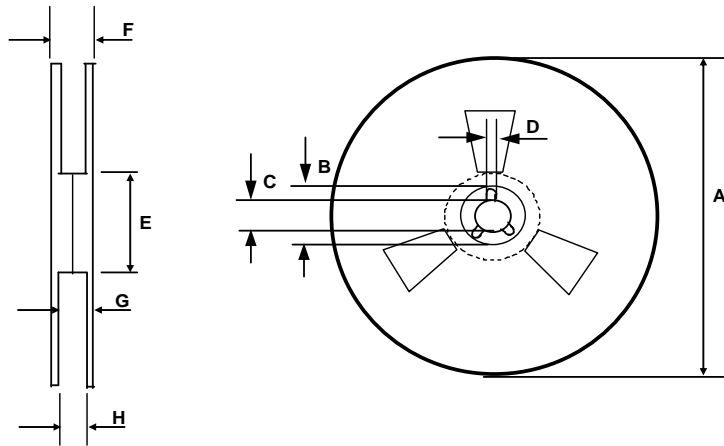

REEL DIMENSIONS FOR 8SOICN

Code	Metric		Imperial	
	Min	Max	Min	Max
A	329.60	330.25	12.976	13.001
B	20.95	21.45	0.824	0.844
C	12.80	13.20	0.503	0.519
D	1.95	2.45	0.767	0.096
E	98.00	102.00	3.858	4.015
F	n/a	18.40	n/a	0.724
G	14.50	17.10	0.570	0.673
H	12.40	14.40	0.488	0.566

LEAD-FREE PART MARKING INFORMATION

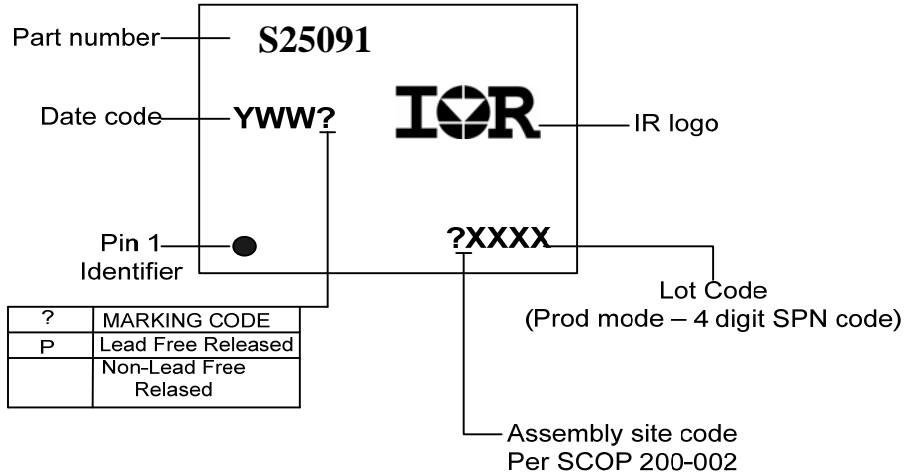

ORDER INFORMATION

8-Lead SOIC IRS25091SPbF

8-Lead SOIC Tape & Reel IRS25091STRPbF

The information provided in this document is believed to be accurate and reliable. However, International Rectifier assumes no responsibility for the consequences of the use of this information. International Rectifier assumes no responsibility for any infringement of patents or of other rights of third parties which may result from the use of this information. No license is granted by implication or otherwise under any patent or patent rights of International Rectifier. The specifications mentioned in this document are subject to change without notice. This document supersedes and replaces all information previously supplied.

For technical support, please contact IR's Technical Assistance Center

<http://www.irf.com/technical-info/>

WORLD HEADQUARTERS:

233 Kansas St., El Segundo, California 90245
Tel: (310) 252-7105

Looking for pricing, stock, or lifecycle information?

Click below to explore more details on WIN SOURCE:

- [View IRS25091STRPBF on WIN SOURCE](#)
- [Rochester Electronics Information](#)

Optimize Your Supply Chain with WIN SOURCE Solutions

- ✓ Global Sourcing Solution
- ✓ Obsolete Management
- ✓ Cost Control Management
- ✓ Shortage Management
- ✓ Alternative Solution
- ✓ Excess Inventory Management