



**THE DATASHEET OF
IR2131JTR**



IR2131(J)(S) & (PbF)

3 HIGH SIDE AND 3 LOW SIDE DRIVER

Features

- Floating channel designed for bootstrap operation Fully operational to +600V Tolerant to negative transient voltage dV/dt immune
- Gate drive supply range from 10 to 20V
- Undervoltage lockout for all channels
- Over-current shutdown turns off all six drivers
- Independent 3 high side & 3 low side drivers
- Matched propagation delay for all channels
- 2.5V logic compatible
- Outputs out of phase with inputs
- 28-Lead SOIC & 44-Lead PLCC are also available in Lead-Free.

Description

The IR2131(J)(S) is a high voltage, high speed power MOSFET and IGBT driver with three independent high and low side referenced output channels. Proprietary HVIC technology enables ruggedized monolithic construction. Logic inputs are compatible with CMOS or LSTTL outputs, down to 2.5V logic. A current trip function which terminates all six outputs can be derived from an external current sense resistor. A shutdown input is provided for a customized shutdown function. An open drain FAULT signal is provided to indicate that any of the shutdowns has occurred. The output drivers feature a high pulse current buffer stage designed for minimum driver cross-conduction. Propagation delays are matched to simplify use in high frequency applications. The floating channels can be used to drive N-channel power MOSFETs or IGBTs in the high side configuration which operate up to 600 volts.

Product Summary

V_{OFFSET}	600V max.
$I_{\text{O}+/-}$	160 mA / 360 mA
V_{OUT}	10 - 20V
$t_{\text{on/off}}$ (typ.)	1.3 & 0.6 μs

Packages

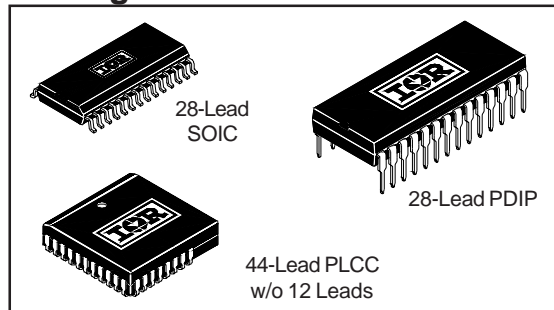

Typical Connection

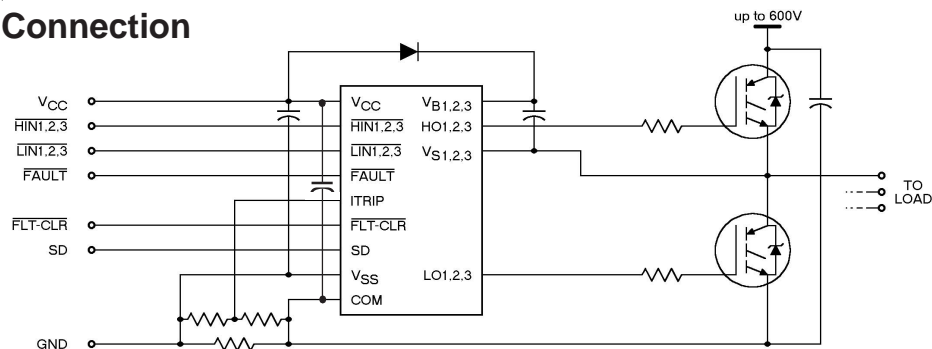

(Refer to Lead Assignments for correct pin configuration). This/These diagram(s) show electrical connections only. Please refer to our Application Notes and DesignTips for proper circuit board layout.

IR2131(J)(S) & (PbF)

Absolute Maximum Ratings

Absolute Maximum Ratings indicate sustained limits beyond which damage to the device may occur. All voltage parameters are absolute voltages referenced to COM. The Thermal Resistance and Power Dissipation ratings are measured under board mounted and still air conditions. Additional Information is shown in Figures 7 through 10.

Symbol	Definition	Min.	Max.	Units
$V_{B1,2,3}$	High Side Floating Supply Voltage	-0.3	625	
$V_{S1,2,3}$	High Side Floating Offset Voltage	$V_{B1,2,3} - 25$	$V_{B1,2,3} + 0.3$	V
$V_{HO1,2,3}$	High Side Floating Output Voltage	$V_{S1,2,3} - 0.3$	$V_{B1,2,3} + 0.3$	
V_{CC}	Low Side and Logic Fixed Supply Voltage	-0.3	25	
V_{SS}	Logic Ground	$V_{CC} - 25$	$V_{CC} + 0.3$	
$V_{LO1,2,3}$	Low Side Output Voltage	-0.3	$V_{CC} + 0.3$	
V_{IN}	Logic Input Voltage (HIN1,2,3, LIN1,2,3, FLT - CLR, SD & ITRIP)	$V_{SS} - 0.3$	($V_{SS} + 15$) or ($V_{CC} + 0.3$) whichever is lower	
V_{FLT}	FAULT Output Voltage	$V_{SS} - 0.3$	$V_{CC} + 0.3$	
dV_S/dt	Allowable Offset Supply Voltage Transient	—	50	V/ns
P_D	Package Power Dissipation @ $T_A \leq +25^\circ\text{C}$			W
	(28 Lead DIP)	—	1.5	
	(28 Lead SOIC)	—	1.6	
	(44 Lead PLCC)	—	2.0	
R_{thJA}	Thermal Resistance, Junction to Ambient			$^\circ\text{C/W}$
	(28 Lead DIP)	—	83	
	(28 Lead SOIC)	—	78	
	(44 Lead PLCC)	—	63	$^\circ\text{C}$
T_J	Junction Temperature	—	150	
T_S	Storage Temperature	-55	150	
T_L	Lead Temperature (Soldering, 10 seconds)	—	300	

Recommended Operating Conditions

The Input/Output logic timing diagram is shown in Figure 1. For proper operation the device should be used within the recommended conditions. All voltage parameters are absolute voltages referenced to COM. The V_S offset rating is tested with all supplies biased at 15V differential.

Symbol	Definition	Min.	Max.	Units
$V_{B1,2,3}$	High Side Floating Supply Voltage	$V_{S1,2,3} + 10$	$V_{S1,2,3} + 20$	V
$V_{S1,2,3}$	High Side Floating Offset Voltage	Note 1	600	
$V_{HO1,2,3}$	High Side Floating Output Voltage	$V_{S1,2,3}$	$V_{B1,2,3}$	
V_{CC}	Low Side and Logic Fixed Supply Voltage	10	20	
V_{SS}	Logic Ground	-5	5	
$V_{LO1,2,3}$	Low Side Output Voltage	0	V_{CC}	
V_{IN}	Logic Input Voltage (HIN1,2,3, LIN1,2,3, FLT - CLR, SD & ITRIP)	V_{SS}	$V_{SS} + 5$	
V_{FLT}	FAULT Output Voltage	V_{SS}	V_{CC}	
T_A	Ambient Temperature	-40	125	$^\circ\text{C}$

Note 1: Logic operational for V_S of -5V to +600V. Logic state held for V_S of -5V to $-V_{BS}$. (Please refer to the Design Tip DT97-3 for more details).

Note 2: All input pins, CA- and CAO pins are internally clamped with a 5.2V zener diode.

Dynamic Electrical Characteristics

$V_{BIAS} (V_{CC}, V_{BS1,2,3}) = 15V$, $V_{S1,2,3} = V_{SS} = COM$, $C_L = 1000$ pF and $T_A = 25^\circ C$ unless otherwise specified. The dynamic electrical characteristics are defined in Figures 4 through 5.

Symbol	Parameter Definition	Value			Units	Test Conditions	
		Min.	Typ.	Max.			
t_{on}	Turn-On Propagation Delay	0.6	1.3	2.0	μs	$V_{IN} = 0$ & $5V$ $V_{S1,2,3} = 0$ to $600V$	
t_{off}	Turn-Off Propagation Delay	0.2	0.6	1.0			
t_r	Turn-On Rise Time	—	80	150	ns		
t_f	Turn-Off Fall Time	—	40	100			
t_{itrip}	ITRIP to Output Shutdown Propagation Delay	400	700	1000			$V_{IN}, V_{ITRIP} = 0$ & $5V$
t_{bl}	ITRIP Blanking Time	—	400	—			$V_{ITRIP} = 1V$
t_{fit}	ITRIP to FAULT Indication Delay	400	700	1000		$V_{IN}, V_{ITRIP} = 0$ & $5V$	
$t_{fit,in}$	Input Filter Time (All Six Inputs)	—	310	—		$V_{IN} = 0$ & $5V$	
t_{fltclr}	FLT - CLR to FAULT Clear Time	400	800	1200		$V_{IN}, V_{IT}, V_{FC} = 0$ & $5V$	
t_{sd}	SD to Output Shutdown Propagation Delay	400	700	1000		$V_{IN}, V_{SD} = 0$ & $5V$	

NOTE: For high side PWM, HIN pulse width must be $\geq 1.5\mu sec$

Static Electrical Characteristics

$V_{BIAS} (V_{CC}, V_{BS1,2,3}) = 15V$, $V_{S1,2,3} = V_{SS} = COM$ and $T_A = 25^\circ C$ unless otherwise specified. The V_{IN} , V_{TH} and I_{IN} parameters are referenced to V_{SS} and are applicable to all six logic input leads: HIN1,2,3 & LIN1,2,3. The V_O and I_O parameters are referenced to COM and $V_{S1,2,3}$ and are applicable to the respective output leads: HO1,2,3 or LO1,2,3.

Symbol	Parameter Definition	Value			Units	Test Conditions
		Min.	Typ.	Max.		
V_{IH}	Logic "0" Input Voltage (OUT = LO)	2.2	—	—	V	
V_{IL}	Logic "1" Input Voltage (OUT = HI)	—	—	0.8		
$V_{FCLR,IH}$	Logic "0" Fault Clear Input Voltage	2.2	—	—		
$V_{FCLR,IL}$	Logic "1" Fault Clear Input Voltage	—	—	0.8		
$V_{SD,TH+}$	Shutdown Input Positive Going Threshold	1.2	1.8	2.1		
$V_{SD,TH-}$	Shutdown Input Negative Going Threshold	0.9	1.5	1.8		
$V_{IT,TH+}$	ITRIP Input Positive Going Threshold	250	485	600	mV	
$V_{IT,TH-}$	ITRIP Input Negative Going Threshold	200	400	550		
V_{OH}	High Level Output Voltage, $V_{BIAS} - V_O$	—	—	100	μA	$V_{IN} = 0V, I_O = 0A$
V_{OL}	Low Level Output Voltage, V_O	—	—	100		$V_{IN} = 5V, I_O = 0A$
I_{LK}	Offset Supply Leakage Current	—	—	50	mA	$V_B = V_S = 600V$
I_{QBS}	Quiescent V_{BS} Supply Current	—	30	100		$V_{IN} = 0V$ or $5V$
I_{QCC}	Quiescent V_{CC} Supply Current	—	3.0	4.5	μA	$V_{IN} = 0V$ or $5V$
I_{IN+}	Logic "1" Input Bias Current (OUT = HI)	—	190	300		$V_{IN} = 0V$
I_{IN-}	Logic "0" Input Bias Current (OUT = LO)	—	50	100	nA	$V_{IN} = 5V$
I_{ITRIP+}	"High" ITRIP Bias Current	—	75	150		ITRIP = 5V
I_{ITRIP-}	"Low" ITRIP Bias Current	—	—	100	ITRIP = 0V	
I_{FCLR+}	Logic "1" Fault Clear Bias Current	—	125	250	μA	FLT - CLR = 0V
I_{FCLR-}	Logic "0" Fault Clear Bias Current	—	75	150		FLT - CLR = 5V
I_{SD+}	Logic "1" Shutdown Bias Current	—	75	150		SD = 5V
I_{SD-}	Logic "0" Shutdown Bias Current	—	—	100		SD = 0V

IR2131(J)(S) & (PbF)

Static Electrical Characteristics -- Continued

V_{BIAS} (V_{CC} , $V_{BS1,2,3}$) = 15V, $V_{S1,2,3} = V_{SS} = COM$ and $T_A = 25^\circ C$ unless otherwise specified. The V_{IN} , V_{TH} and I_{IN} parameters are referenced to V_{SS} and are applicable to all six logic input leads: HIN1,2,3 & LIN1,2,3. The V_O and I_O parameters are referenced to COM and $V_{S1,2,3}$ and are applicable to the respective output leads: HO1,2,3 or LO1,2,3.

Symbol	Parameter Definition	Value			Units	Test Conditions
		Min.	Typ.	Max.		
V_{BSUV+}	V_{BS} Supply Undervoltage Positive Going Threshold	8.2	8.7	9.2	V	
V_{BSUV-}	V_{BS} Supply Undervoltage Negative Going Threshold	7.8	8.3	8.8		
V_{CCUV+}	V_{CC} Supply Undervoltage Positive Going Threshold	8.2	8.7	9.2		
V_{CCUV-}	V_{CC} Supply Undervoltage Negative Going Threshold	7.8	8.3	8.8		
$R_{on,FLT}$	\overline{FAULT} Low On-Resistance	—	55	75	Ω	
I_{O+}	Output High Short Circuit Pulsed Current	160	250	—	mA	$V_O = 0V, V_{IN} = 0V$ $PW \leq 10 \mu s$
I_{O-}	Output Low Short Circuit Pulsed Current	360	500	—		$V_O = 15V, V_{IN} = 5V$ $PW \leq 10 \mu s$

Functional Block Diagram

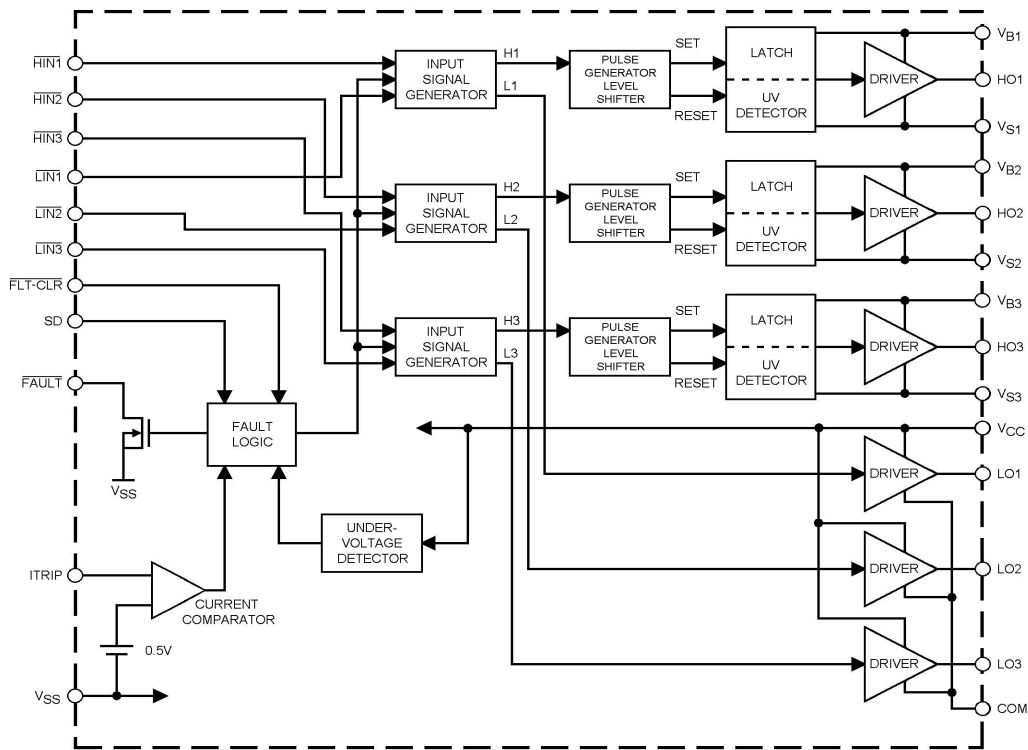

Lead Definitions

Lead	
Symbol	Description
HIN1,2,3	Logic inputs for high side gate driver outputs (HO1,2,3), out of phase
LIN1,2,3	Logic inputs for low side gate driver output (LO1,2,3), out of phase
FLT-CLR	Logic input for fault clear
SD	Logic input for shutdown
FAULT	Indicates over-current or undervoltage lockout (low side) has occurred, negative logic
VCC	Low side and logic fixed supply
ITRIP	Input for over-current shutdown
VSS	Logic ground
VB1,2,3	High side floating supplies
HO1,2,3	High side gate drive outputs
VS1,2,3	High side floating supply returns
LO1,2,3	Low side gate drive outputs
COM	Low side return

Lead Assignments

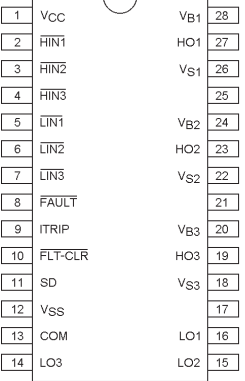
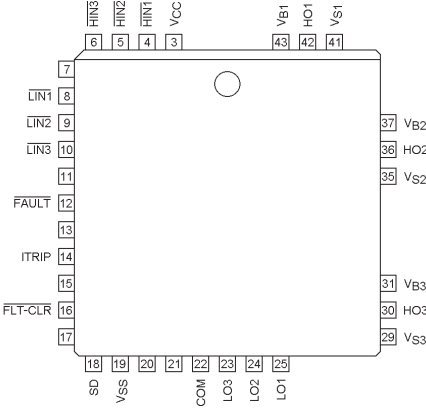
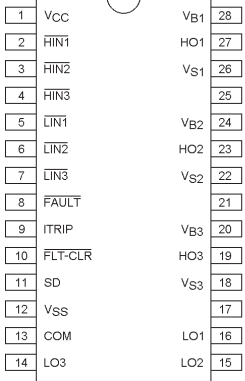
 <p>28 Lead DIP</p>	 <p>44 Lead PLCC w/o 12 Leads</p>	 <p>28 Lead SOIC (Wide Body)</p>
IR2131	IR2131J	IR2131S
Part Number		

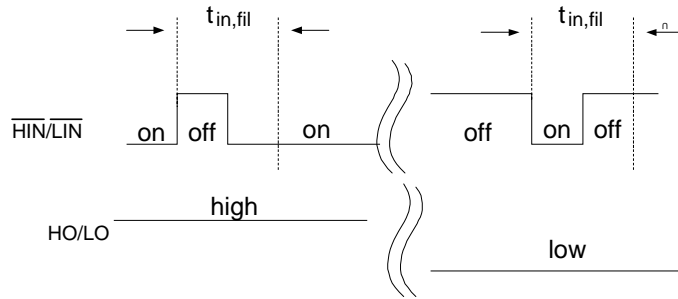

Figure 6.5 Input Filter Function

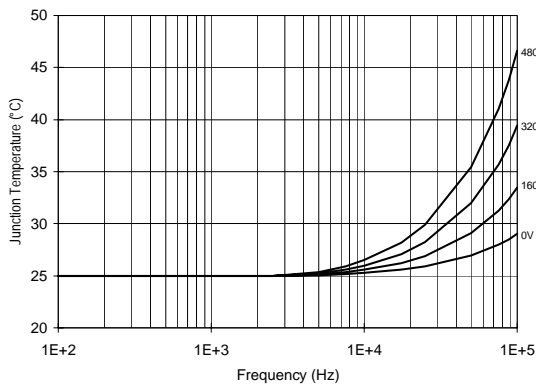

Figure 7. IR2131 T_J vs. Frequency (IRF820)
 $R_{GATE} = 33\Omega$, $V_{CC} = 15V$

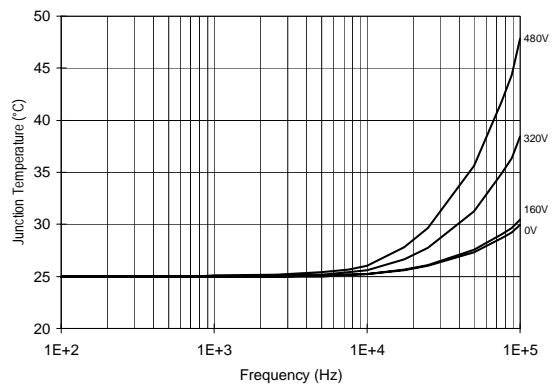

Figure 8. IR2131 T_J vs. Frequency (IRF830)
 $R_{GATE} = 20\Omega$, $V_{CC} = 15V$

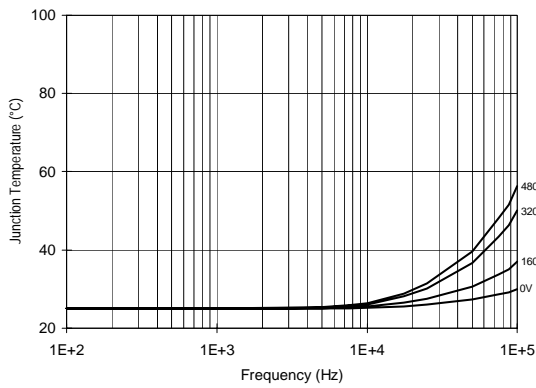

Figure 9. IR2131 T_J vs. Frequency (IRF840)
 $R_{GATE} = 15\Omega$, $V_{CC} = 15V$

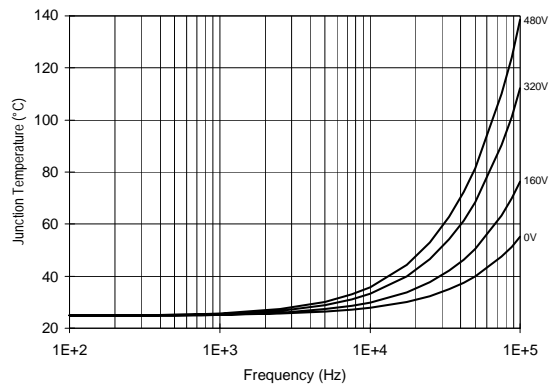
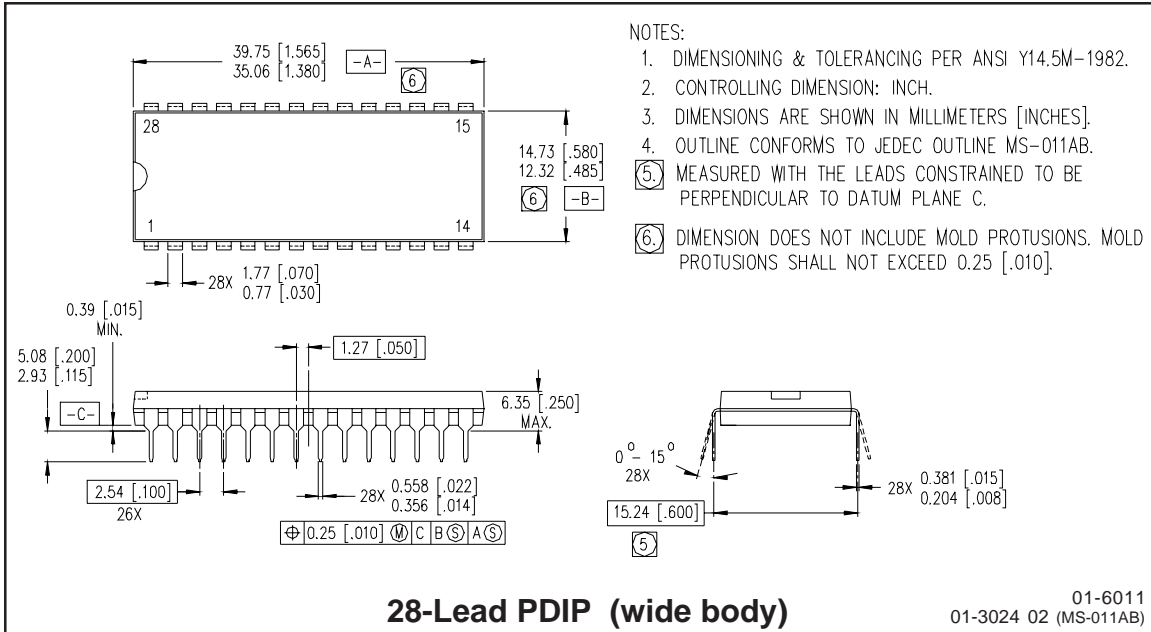

Figure 10. IR2131 T_J vs. Frequency (IRF450)
 $R_{GATE} = 10\Omega$, $V_{CC} = 15V$

IR2131(J)(S) & (PbF)

International
IR Rectifier

Case outlines



NOTES:

1. DIMENSIONING & TOLERANCING PER ANSI Y14.5M-1982.
2. CONTROLLING DIMENSION: INCH.
3. DIMENSIONS ARE SHOWN IN MILLIMETERS [INCHES].
4. OUTLINE CONFORMS TO JEDEC OUTLINE MS-011AB.
- ⑤ MEASURED WITH THE LEADS CONSTRAINED TO BE PERPENDICULAR TO DATUM PLANE C.
- ⑥ DIMENSION DOES NOT INCLUDE MOLD PROTUSIONS. MOLD PROTUSIONS SHALL NOT EXCEED 0.25 [.010].

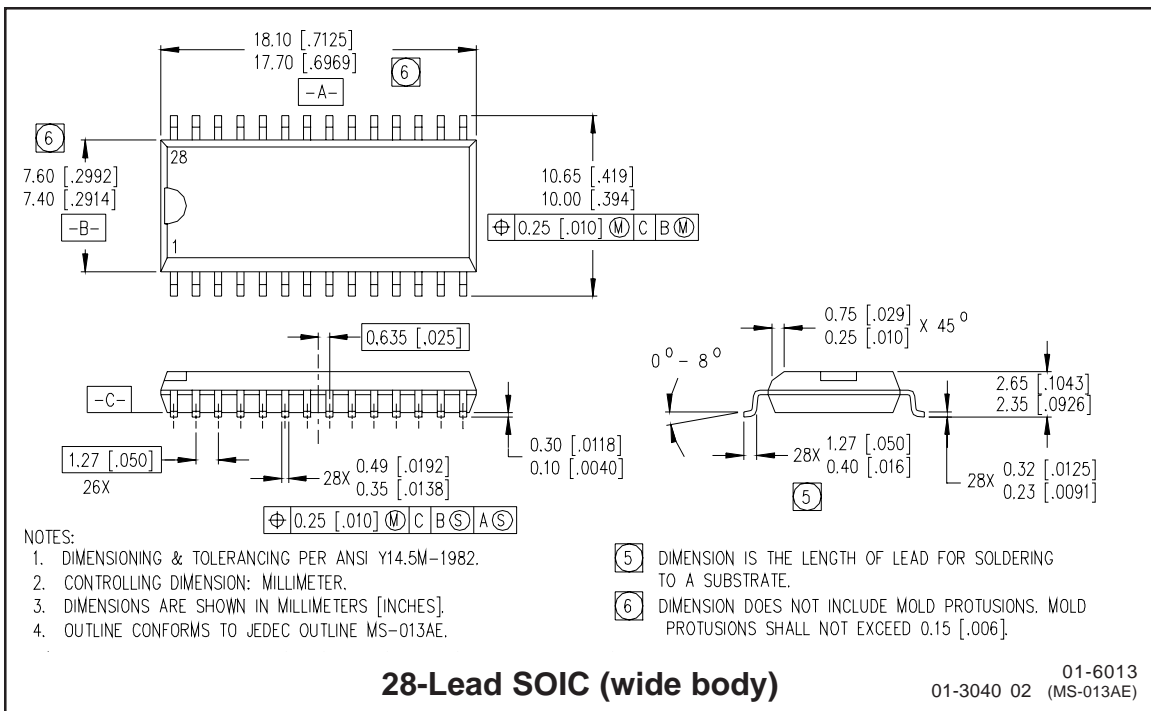

NOTES:

1. DIMENSIONING & TOLERANCING PER ANSI Y14.5M-1982.
2. CONTROLLING DIMENSION: MILLIMETER.
3. DIMENSIONS ARE SHOWN IN MILLIMETERS [INCHES].
4. OUTLINE CONFORMS TO JEDEC OUTLINE MS-013AE.
- ⑤ DIMENSION IS THE LENGTH OF LEAD FOR SOLDERING TO A SUBSTRATE.
- ⑥ DIMENSION DOES NOT INCLUDE MOLD PROTUSIONS. MOLD PROTUSIONS SHALL NOT EXCEED 0.15 [.006].

IR2131(J)(S) & (PbF)

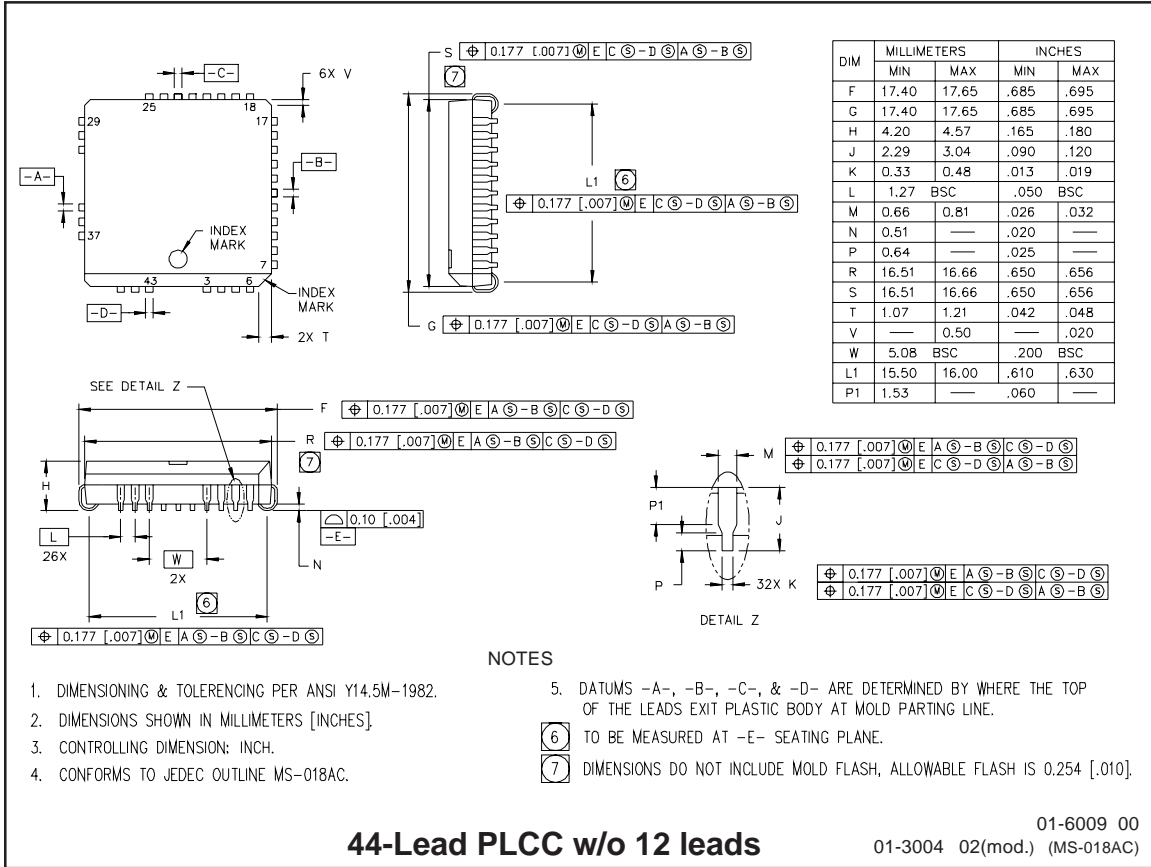

44-Lead PLCC w/o 12 leads

01-6009 00
01-3004 02(mod.) (MS-018AC)

IR2131(J)(S) & (PbF)

International
IR Rectifier

LEADFREE PART MARKING INFORMATION

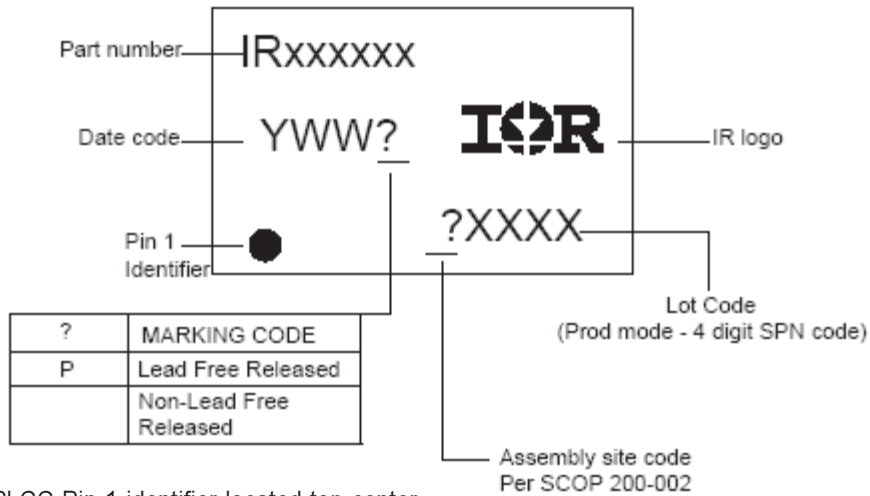

* PLCC Pin 1 identifier located top center

ORDER INFORMATION

Basic Part (Non-Lead Free)

28-Lead PDIP	IR2131	order	IR2131
28-Lead SOIC	IR2131S	order	IR2131S
44-Lead PLCC	IR2131J	order	IR2131J

Lead-Free Part

28-Lead PDIP	IR2131	order	Not available
28-Lead SOIC	IR2131S	order	IR2131SPbF
44-Lead PLCC	IR2131J	order	IR2131JPbF

International
IR Rectifier

This product has been designed and qualified for the Industrial market.
Qualification Standards can be found on IR's Web site.
Data and specifications subject to change without notice.

IR WORLD HEADQUARTERS: 233 Kansas St., El Segundo, California 90245, USA Tel: (310) 252-7105
TAC Fax: (310) 252-7903

Visit us at www.irf.com for sales contact information.

10/11/04

Looking for pricing, stock, or lifecycle information?

Click below to explore more details on WIN SOURCE:

 [View IR2131JTR on WIN SOURCE](#)

 [Infineon Technologies](#) Information

Optimize Your Supply Chain with WIN SOURCE Solutions

-  Global Sourcing Solution
-  Obsolete Management
-  Cost Control Management
-  Shortage Management
-  Alternative Solution
-  Excess Inventory Management