



**THE DATASHEET OF
IL 717ETR13**



High Speed Four-Channel Digital Isolators

Functional Diagrams

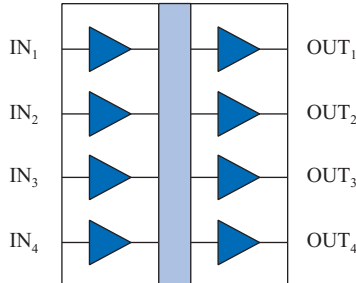

IL715

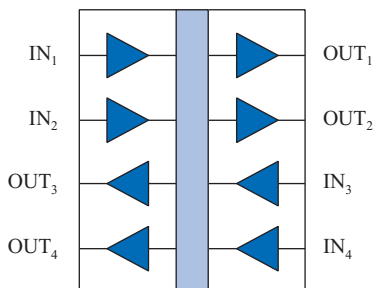

IL716

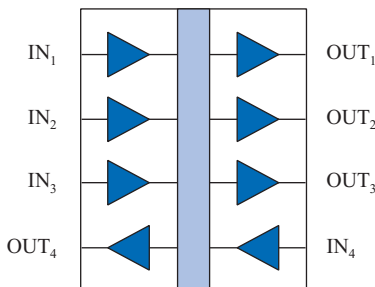

IL717

Features

- High speed: 110 Mbps
- High temperature: $-40\text{ }^{\circ}\text{C}$ to $+125\text{ }^{\circ}\text{C}$ (“T” and “V” Series)
- Very high isolation: 7 kV_{RMS} Reinforced Isolation (V-Series)
- 2.7 to 5.5 volt supply range
- 100 kV/ μs Common Mode Transient Immunity
- No carrier or clock for low EMI emissions and susceptibility
- 100 ps pulse jitter
- 2 ns channel-to-channel skew
- 10 ns typical propagation delay
- 1.2 mA/channel typical quiescent current
- 44000 year barrier life
- Excellent magnetic immunity
- IEC 60747-17 (VDE 0884-17):2021-10 certified; UL 1577 recognized
- 7 kV_{RMS} Reinforced Isolation; 1.2 kV_{RMS} Working Voltage (V-series)
- ATEX / IECEx certified for IS-to-IS intrinsically-safe applications
- 0.15" and 0.3" True 8TM mm 16-pin SOIC; 16-pin QSOP packages

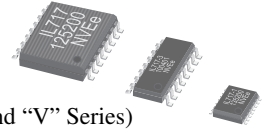

Applications

- ADCs and DACs
- Digital Fieldbus
- Multiplexed data transmission
- Board-to-board communication
- Ground loop elimination
- Parallel bus
- Logic level shifting
- Equipment covered under IEC 61010-1 Edition 3
- 5 kV_{RMS} rated IEC 60601-1 medical applications

Description

NVE’s IL715, IL716, and IL717 four-channel high-speed digital isolators are CMOS devices manufactured with NVE’s patented* spintronic Giant Magnetoresistive (GMR) technology.

A unique ceramic/polymer composite barrier provides excellent isolation and virtually unlimited barrier life.

All transmit and receive channels operate at 110 Mbps over the full temperature and supply voltage range. The symmetric magnetic coupling barrier provides typical propagation delay of only 10 ns, pulse width distortion of 2 ns, and 100 ps pulse jitter, which are best-in-class.

Minimum transient immunity of 100 kV/ μs is unsurpassed. High channel density makes these devices ideal for isolating ADCs and DACs, parallel buses and peripheral interfaces.

The IL715, IL716, and IL717 are available in 16-pin 0.3" and 0.15" SOIC, and ultraminiature QSOP packages.

V-Series versions have an extremely high isolation voltage of 7 kV_{RMS}.

“T” and “V” Series parts have a maximum operating temperature of 125 °C.

Absolute Maximum Ratings

Parameters	Symbol	Min.	Typ.	Max.	Units	Test Conditions
Storage Temperature	T_S	-55		150	°C	
Junction Temperature	T_J	-55		150	°C	
Ambient Operating Temperature ⁽¹⁾	T_A	-55		130	°C	
Supply Voltage	V_{DD1}, V_{DD2}	-0.5		7	V	
Input Voltage	V_I	-0.5		$V_{DD}+0.5$	V	
Output Voltage	V_O	-0.5		$V_{DD}+0.5$	V	
Output Current Drive	I_O			10	mA	
Lead Solder Temperature				260	°C	10 sec.
ESD			2		kV	HBM

Recommended Operating Conditions

Parameters	Symbol	Min.	Typ.	Max.	Units	Test Conditions
Ambient Operating Temperature “T” and “V” Versions All other part types	T_A	-40		125 100	°C	
Junction Temperature “T” and “V” Versions All other part types	T_J	-40		125 110	°C	
Supply Voltage “V” Versions All other part types	V_{DD1}, V_{DD2}	2.95 2.7		5.5 5.5	V	
Logic High Input Voltage	V_{IH}	2.4		V_{DD}	V	
Logic Low Input Voltage	V_{IL}	0		0.8	V	
Input Signal Rise and Fall Times	t_{IR}, t_{IF}			1	μs	

Safety and Approvals

IEC 60747-17 (VDE 0884-17):2021-10:

“VE” version (Reinforced Isolation; VDE File Number 5016933-4880-0002)

- Working Voltage (V_{IORM}): 1200 V_{RMS} (1700 V_{PK}) with 20% Safety Factor; pollution degree 2
- Isolation voltage (V_{ISO}):
6000 V_{RMS} (8485 V_{PK}), lot codes <240900
7000 V_{RMS} (9900 V_{PK}); pending, lot codes \geq 240900
- Surge immunity (V_{IOSM}): 12.8 kV $_{PK}$
- Surge rating: 8000 V
- Transient overvoltage (V_{IOTM}): 6000 V_{PK}
- Each part tested at 2387 V_{PK} for 1 second, 5 pC partial discharge limit
- Samples tested at 6000 V_{PK} for 60 sec.; then 2122 V_{PK} for 10 sec. with 5 pC partial discharge limit

Standard versions (Basic Isolation; VDE File Number 5016933-4880-0001)

- Isolation voltage (V_{ISO}): 2500 V_{RMS}
- Transient overvoltage (V_{IOTM}): 4000 V_{PK}
- Surge rating: 4000 V
- Each part tested at 1590 V_{PK} for 1 second, 5 pC partial discharge limit.
- Samples tested at 4000 V_{PK} for 60 sec.; then 1358 V_{PK} for 10 sec. with 5 pC partial discharge limit.
- Working Voltage (V_{IORM} ; pollution degree 2):

Package	Part No. Suffix	Working Voltage
QSOP16	-1	600 V_{RMS}
Narrow-body SOIC16	-3	700 V_{RMS}
Wide-body SOIC16/True 8™	None	600 V_{RMS}

Safety-Limiting Values	Symbol	Value	Units
Safety rating ambient temperature	T_S	180	°C
Safety rating power (180 °C)	P_S	270	mW
Supply current safety rating (total of supplies)	I_S	54	mA

UL 1577 (Component Recognition Program File Number E207481)

Standard isolation grade

2500 V rating; each part tested at 3000 V_{RMS} (4243 V_{PK}) for 1 second; each lot sample tested at 2500 V_{RMS} (3536 V_{PK}) for 1 minute.

V-Series isolation grade

7 kV rating; each part tested at 8.4 kV $_{RMS}$ (11.88 kV $_{PK}$) for 1 second; each lot sample tested at 7 kV $_{RMS}$ (9.9 kV $_{PK}$) for 1 minute.

IEC 62368-1:2023 (audio/video, information, and communication technology equipment)

Part 1: Safety requirements

Intrinsically Safe Certification

- “VE” versions are ATEX / IEC 60079-0 / 60079-11 certified Intrinsically Safe (IS) for use in IS to IS applications.
- 500 V_{RMS} rating.

Soldering Profile

Per JEDEC J-STD-020C, MSL 1

IL715 Pin Connections

1	V _{DD1}	Supply voltage
2	GND ₁	Ground return for V _{DD1} *
3	IN ₁	Data in, channel 1
4	IN ₂	Data in, channel 2
5	IN ₃	Data in, channel 3
6	IN ₄	Data in, channel 4
7	NC	No connection
8	GND ₁	Ground return for V _{DD1} *
9	GND ₂	Ground return for V _{DD2} *
10	NC	No connection
11	OUT ₄	Data out, channel 4
12	OUT ₃	Data out, channel 3
13	OUT ₂	Data out, channel 2
14	OUT ₁	Data out, channel 1
15	GND ₂	Ground return for V _{DD2} *
16	V _{DD2}	Supply voltage

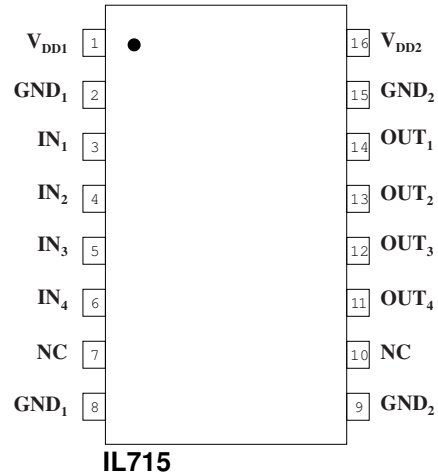

IL716 Pin Connections

1	V _{DD1}	Supply voltage
2	GND ₁	Ground Return for V _{DD1} *
3	IN ₁	Data in, channel 1
4	IN ₂	Data in, channel 2
5	OUT ₃	Data out, channel 3
6	OUT ₄	Data out, channel 4
7	NC	No connection
8	GND ₁	Ground Return for V _{DD1} *
9	GND ₂	Ground Return for V _{DD2} *
10	NC	No connection
11	IN ₄	Data in, channel 4
12	IN ₃	Data in, channel 3
13	OUT ₂	Data out, channel 2
14	OUT ₁	Data out, channel 1
15	GND ₂	Ground Return for V _{DD2} *
16	V _{DD2}	Supply voltage

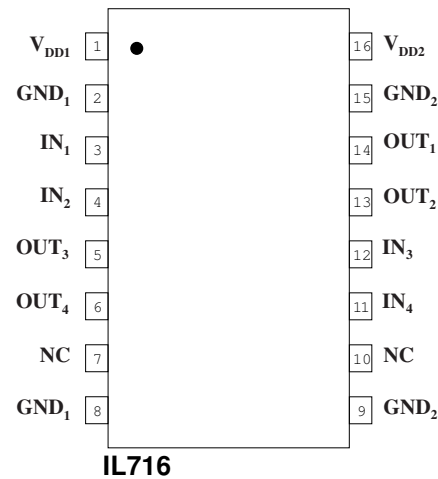

*NOTE: Pins 2 and 8 are internally connected, as are pins 9 and 15.

IL717 Pin Connections

1	V _{DD1}	Supply voltage
2	GND ₁	Ground return for V _{DD1} *
3	IN ₁	Data in, channel 1
4	IN ₂	Data in, channel 2
5	IN ₃	Data in, channel 3
6	OUT ₄	Data out, channel 4
7	NC	No connection
8	GND ₁	Ground return for V _{DD1} *
9	GND ₂	Ground return for V _{DD2} *
10	NC	No connection
11	IN ₄	Data in, channel 4
12	OUT ₃	Data out, channel 3
13	OUT ₂	Data out, channel 2
14	OUT ₁	Data out, channel 1
15	GND ₂	Ground return for V _{DD2} *
16	V _{DD2}	Supply voltage

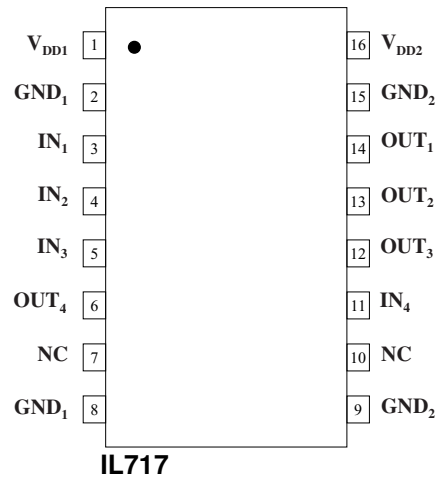

*NOTE: Pins 2 and 8 are internally connected, as are pins 9 and 15.

Timing Diagram

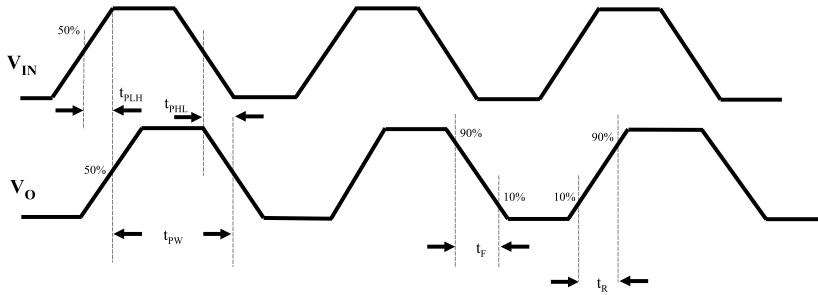

Legend

t _{PLH}	Propagation Delay, Low to High
t _{PHL}	Propagation Delay, High to Low
t _{PW}	Minimum Pulse Width
t _R	Rise Time
t _F	Fall Time

3.3 Volt Electrical Specifications (T _{min} to T _{max} unless otherwise stated)						
Parameters	Symbol	Min.	Typ.	Max.	Units	Test Conditions
Input Quiescent Supply Current						
IL715 and IL715-3	I _{DD1}		16	20	μA	
IL715-1			300	400	μA	
IL716			2.4	3.5	mA	
IL717			1.2	1.75	mA	
Output Quiescent Supply Current						
IL715	I _{DD2}		4.8	7	mA	
IL716			2.4	3.5	mA	
IL717			3.6	5.25	mA	
Logic Input Current	I _I	-10		10	μA	
Logic High Output Voltage	V _{OH}	$V_{DD} - 0.1$ $0.8 \times V_{DD}$	V_{DD} $0.9 \times V_{DD}$		V	I _O = -20 μA, V _I = V _{IH} I _O = -4 mA, V _I = V _{IH}
Logic Low Output Voltage	V _{OL}		0 0.5	0.1 0.8	V	I _O = 20 μA, V _I = V _{IL} I _O = 4 mA, V _I = V _{IL}

Switching Specifications (V _{DD} = 3.3 V)						
Maximum Data Rate		100	110		Mbps	C _L = 15 pF
Pulse Width ⁽⁷⁾	PW	10			ns	50% Points, V _O
Propagation Delay Input to Output (High to Low)	t _{PHL}		12	18	ns	C _L = 15 pF
Propagation Delay Input to Output (Low to High)	t _{PLH}		12	18	ns	C _L = 15 pF
Pulse Width Distortion ⁽²⁾	PWD		2	3	ns	C _L = 15 pF
Propagation Delay Skew ⁽³⁾	t _{PSK}		4	6	ns	C _L = 15 pF
Output Rise Time (10%–90%)	t _r		2	4	ns	C _L = 15 pF
Output Fall Time (10%–90%)	t _f		2	4	ns	C _L = 15 pF
Common Mode Transient Immunity (Output Logic High or Logic Low) ⁽⁴⁾	ICM _H ICM _L	100	150		kV/μs	Per IEC 60747
Channel-to-Channel Skew	t _{CSK}		2	3	ns	C _L = 15 pF
Dynamic Power Consumption ⁽⁶⁾						
Input side			140	240	μA/Mbps/ch	
Output side			20	40		

Magnetic Field Immunity ⁽⁸⁾ (V _{DD2} = 3.3 V, V _{DD1MIN} < V _{DD2} < V _{DD2MAX})						
Power Frequency Magnetic Immunity	H _{PF}		1500		A/m	50Hz/60Hz
Pulse Magnetic Field Immunity	H _{PM}		2000		A/m	t _p = 8μs
Damped Oscillatory Magnetic Field	H _{OSC}		2000		A/m	0.1Hz – 1MHz
Cross-axis Immunity Multiplier ⁽⁹⁾	K _X		2.5			

5 Volt Electrical Specifications (T _{min} to T _{max} unless otherwise stated)						
Parameters	Symbol	Min.	Typ.	Max.	Units	Test Conditions
Input Quiescent Supply Current						
IL715 and IL715-3	I _{DD1}		24	30	μA	
IL715-1			350	500	μA	
IL716			3.6	5	mA	
IL717			1.8	2.5	mA	
Output Quiescent Supply Current						
IL715	I _{DD2}		7.2	10	mA	
IL716			3.6	5	mA	
IL717			5.4	7.5	mA	
Logic Input Current	I _I	-10		10	μA	
Logic High Output Voltage	V _{OH}	$V_{DD} - 0.1$ $0.8 \times V_{DD}$	V_{DD} $0.9 \times V_{DD}$		V	I _O = -20 μA, V _I = V _{IH} I _O = -4 mA, V _I = V _{IH}
Logic Low Output Voltage	V _{OL}		0 0.5	0.1 0.8	V	I _O = 20 μA, V _I = V _{IL} I _O = 4 mA, V _I = V _{IL}

Switching Specifications ($V_{DD} = 5V$)						
Maximum Data Rate		100	110		Mbps	$C_L = 15\text{ pF}$
Pulse Width ⁽⁷⁾	PW	10			ns	50% Points, V_O
Propagation Delay Input to Output (High to Low)	t_{PHL}		10	15	ns	$C_L = 15\text{ pF}$
Propagation Delay Input to Output (Low to High)	t_{PLH}		10	15	ns	$C_L = 15\text{ pF}$
Pulse Width Distortion ⁽²⁾	PWD		2	3		$C_L = 15\text{ pF}$
Pulse Jitter ⁽¹⁰⁾	t_j		100		ps	$C_L = 15\text{ pF}$
Propagation Delay Skew ⁽³⁾	t_{PSK}		4	6	ns	$C_L = 15\text{ pF}$
Output Rise Time (10%–90%)	t_R		1	3	ns	$C_L = 15\text{ pF}$
Output Fall Time (10%–90%)	t_F		1	3	ns	$C_L = 15\text{ pF}$
Common Mode Transient Immunity (Output Logic High or Logic Low) ⁽⁴⁾	$ ICM_H , ICM_L $	100	150		kV/ μs	Per IEC 60747
Channel-to-Channel Skew	t_{CSK}		2	3	ns	$C_L = 15\text{ pF}$
Dynamic Power Consumption ⁽⁶⁾						
Output side			140	240	$\mu\text{A}/\text{Mbps}/\text{ch}$	
Input side			30	50		

Magnetic Field Immunity ⁽⁸⁾ ($V_{DD2} = 5\text{ V}$, $V_{DD1MIN} < V_{DD2} < V_{DD2MAX}$)						
Power Frequency Magnetic Immunity	H_{PF}		3500		A/m	50Hz/60Hz
Pulse Magnetic Field Immunity	H_{PM}		4500		A/m	$t_p = 8\mu\text{s}$
Damped Oscillatory Magnetic Field	H_{OSC}		4500		A/m	0.1Hz – 1MHz
Cross-axis Immunity Multiplier ⁽⁹⁾	K_X		2.5			

Insulation Specifications							
Parameter		Symbol	Min.	Typ.	Max.	Units	Test Conditions
Creepage Distance (external)	QSOP		4.03				Per IEC 60601
	0.15" SOIC		4.03			mm	
	0.3" SOIC		8.03	8.3			
Total Barrier Thickness (internal)			0.012	0.016		mm	
Leakage Current ⁽⁵⁾				0.2		μA	240 V _{RMS} , 60 Hz
Barrier Resistance ⁽⁵⁾				>10 ¹⁴		Ω	500 V
Barrier Capacitance ⁽⁵⁾				4		pF	f = 1 MHz
Comparative Tracking Index	QSOP	CTI	≥175			V _{RMS}	Per IEC 60112
	0.15" SOIC		≥175				
	0.3" SOIC		≥600				
High Voltage Endurance (Maximum Barrier Voltage for Indefinite Life)	AC	V _{IO}	1000			V _{RMS}	At maximum operating temperature
	DC		1500			V _{DC}	
Surge Immunity ("V" Versions)		V _{IOSM}	12.8			kV _{PK}	Per IEC 61000-4-5
Barrier Life				44000		Years	100°C, 1000 V _{RMS} , 60% CL activation energy

Thermal Characteristics								
Parameter		Symbol	Min.	Typ.	Max.	Units	Test Conditions	
Junction–Ambient Thermal Resistance	QSOP	θ _{JA}		100		°C/W	Double-sided PCB in free air	
	0.15" SOIC16			82				
	0.3" SOIC16			67				
Junction–Case (Top) Thermal Resistance	QSOP	θ _{JC}		9			°C/W	Double-sided PCB in free air
	0.15" SOIC16			8				
	0.3" SOIC16			12				
Junction–Ambient Thermal Resistance	0.3" SOIC	θ _{JA}		46		°C/W		2s2p PCB in free air per JESD51
			Junction–Case (Top) Thermal Resistance	θ _{JC}				
Power Dissipation	QSOP	P _D						
	0.15" SOIC16				675			
	0.3" SOIC16				1500			

Notes (apply to both 3.3 V and 5 V specifications):

1. Absolute maximum ambient operating temperature means the device will not be damaged if operated under these conditions. It does not guarantee performance.
2. PWD is defined as $t_{PHL} - t_{PLH}$. %PWD is equal to PWD divided by pulse width.
3. t_{PSK} is the magnitude of the worst-case difference in t_{PHL} and/or t_{PLH} between devices at 25 °C.
4. CM_H and CM_L are the maximum common mode voltage slew rates that can be applied with the outputs remaining stable and within V_{OL} and V_{OH} specifications.
5. Device is considered a two terminal device: pins 1–8 shorted and pins 9–16 shorted.
6. Dynamic power consumption is calculated per channel.
7. Minimum pulse width is the minimum value at which specified PWD is guaranteed.
8. The relevant test and measurement methods are given in the Electromagnetic Compatibility section on p. 10.
9. External magnetic field immunity is improved by this factor if the field direction is “end-to-end” rather than to “pin-to-pin” (see diagram on p. 10).
10. 66,535-bit pseudo-random binary signal (PRBS) NRZ bit pattern with no more than five consecutive 1s or 0s; 800 ps transition time.

Typical Performance Graphs

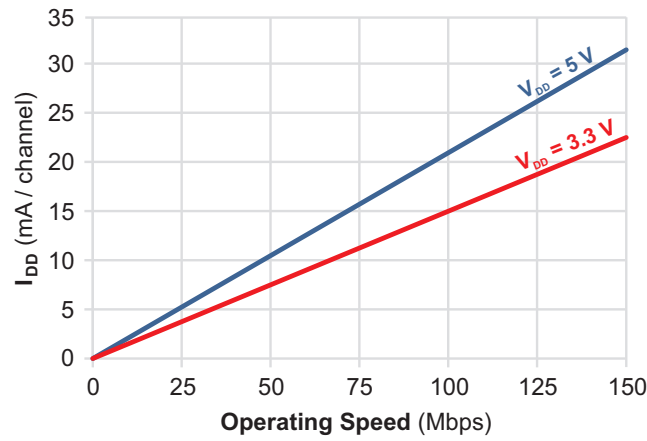

Figure 1. Supply current (per channel) vs. operating speed.

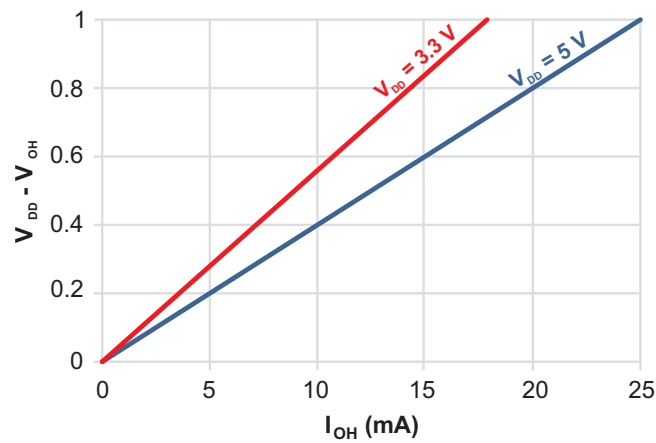

Figure 2. Typical high output voltage vs. load.

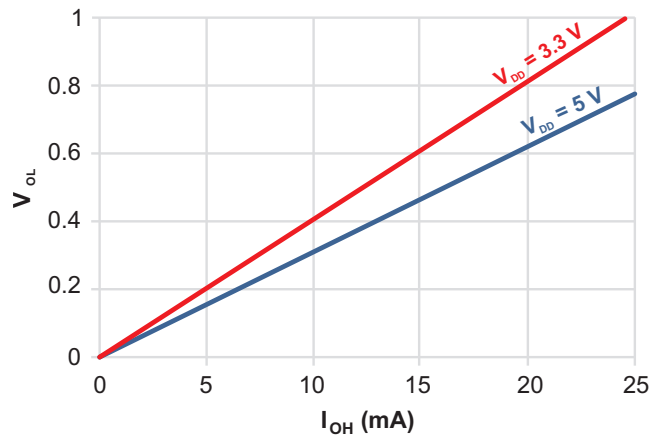

Figure 3. Typical low output voltage vs. load

Application Information

Isolator Operation

An equivalent circuit is shown below:

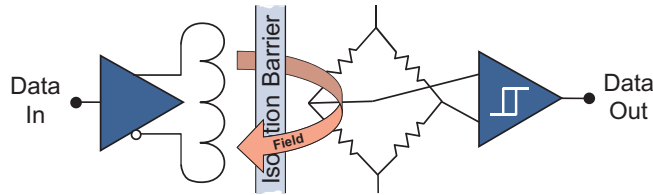

Figure 4. IL715/IL716/IL717 equivalent circuit (each channel).

Isolator Signal Path

The GMR isolator signal path starts with a buffered input signal that is driven through an ultraminiature coil. This generates a small magnetic field that changes the electron spin polarization of GMR resistors, which are configured as a Wheatstone bridge. The change in spin polarization of the resistors creates a bridge voltage which drives an output comparator to construct an isolated version of the input signal.

Small Size, High Speed, and Low EMI

The coil, GMR, and circuitry are integrated to allow small packages. GMR is inherently high speed and low distortion, and unlike transformers, does not rely on energy transfer, so power is low and EMI emissions are minimal.

High Magnetic Immunity

GMR provides large signals which improve magnetic immunity, and the Wheatstone bridge configuration cancels ambient common-mode magnetic fields, further enhancing immunity to external magnetic fields.

Electrostatic Discharge Sensitivity

This product has been tested for electrostatic sensitivity to the limits stated in the specifications. However, NVE recommends that all integrated circuits be handled with appropriate care to avoid damage. Damage caused by inappropriate handling or storage could range from performance degradation to complete failure.

Electromagnetic Compatibility

IsoLoop Isolators have the lowest EMC footprint of any isolation technology. IsoLoop Isolators' Wheatstone bridge configuration and differential magnetic field signaling ensure excellent EMC performance against all relevant standards.

These isolators are fully compliant with IEC 61000-6-1 and IEC 61000-6-2 standards for immunity, and IEC 61000-6-3, IEC 61000-6-4, CISPR, and FCC Class A standards for emissions.

Immunity to external magnetic fields is even higher if the field direction is "end-to-end" rather than to "pin-to-pin" as shown in the diagram below:

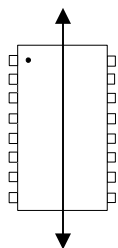

Cross-axis Field Direction

Dynamic Power Consumption

IsoLoop Isolators achieve their low power consumption from the way they transmit data across the isolation barrier. By detecting the edge transitions of the input logic signal and converting these to narrow current pulses, a magnetic field is created around the GMR Wheatstone bridge. Depending on the direction of the magnetic field, the bridge causes the output comparator to switch following the input logic signal. Since the current pulses are narrow, about 2.5 ns, the power consumption is independent of mark-to-space ratio and solely dependent on frequency. This has obvious advantages over optocouplers, which have power consumption heavily dependent on mark-to-space ratio.

Thermal Management

IsoLoop Isolators are designed for low power dissipation and thermal performance, providing unmatched channel density for high-performance isolators. Nevertheless, package temperature rise should be considered when running multiple channels at high speed. Power consumption is higher at 5 volt operation than at 3.3 volts, and dynamic supply current is higher on the input side of the isolators than the output side, so thermal management is more important with five-volt input-side power supplies.

Based on the specifications contained in this datasheet, the derating curve at typical operating conditions is as follows:

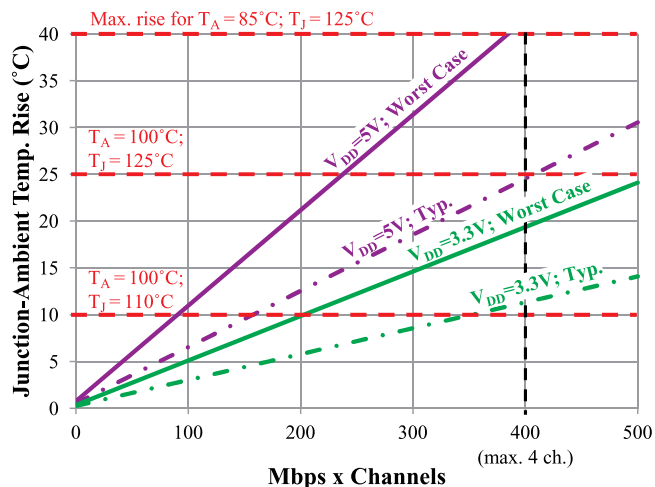

Standard-grade parts have a maximum junction temperature of 110°C. T-Series parts have a maximum operating junction temperature of 125°C for additional margin at extreme operating conditions.

Power Supply Decoupling

Both power supplies should be decoupled with 0.1 μF typical (0.047 μF minimum) capacitors as close as possible to the V_{DD} pins. Ground planes for both GND₁ and GND₂ are highly recommended for data rates above 10 Mbps.

Maintaining Creepage

Creepage distances are often critical in isolated circuits. In addition to meeting JEDEC standards, NVE isolator packages have unique creepage specifications. Standard pad libraries often extend under the package, compromising creepage and clearance. Similarly, ground planes, if used, should be spaced to avoid compromising clearance. Package drawings and recommended pad layouts are included in this datasheet.

Signal Status on Start-up and Shut Down

To minimize power dissipation, input signals are differentiated and then latched on the output side of the isolation barrier to reconstruct the signal. This could result in an ambiguous output state depending on power up, shutdown and power loss sequencing. Therefore, the designer should consider including an initialization signal in the start-up circuit. Initialization consists of toggling the input either high then low, or low then high.

Application Diagrams

Isolated Logic Level Shifters

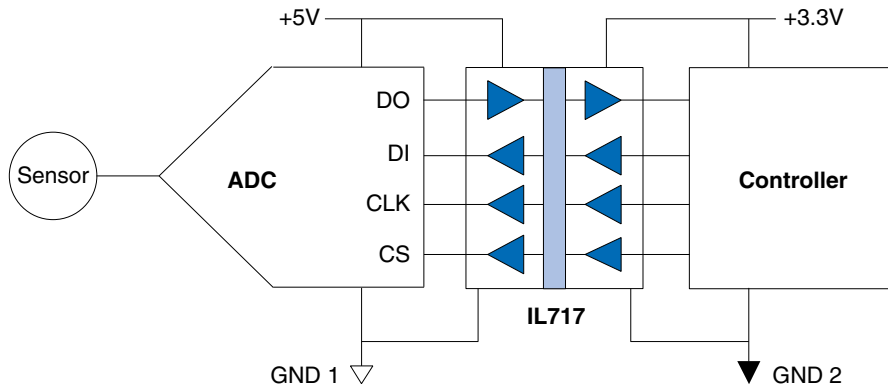

Single-Channel Isolated Delta-Sigma A/D Converter

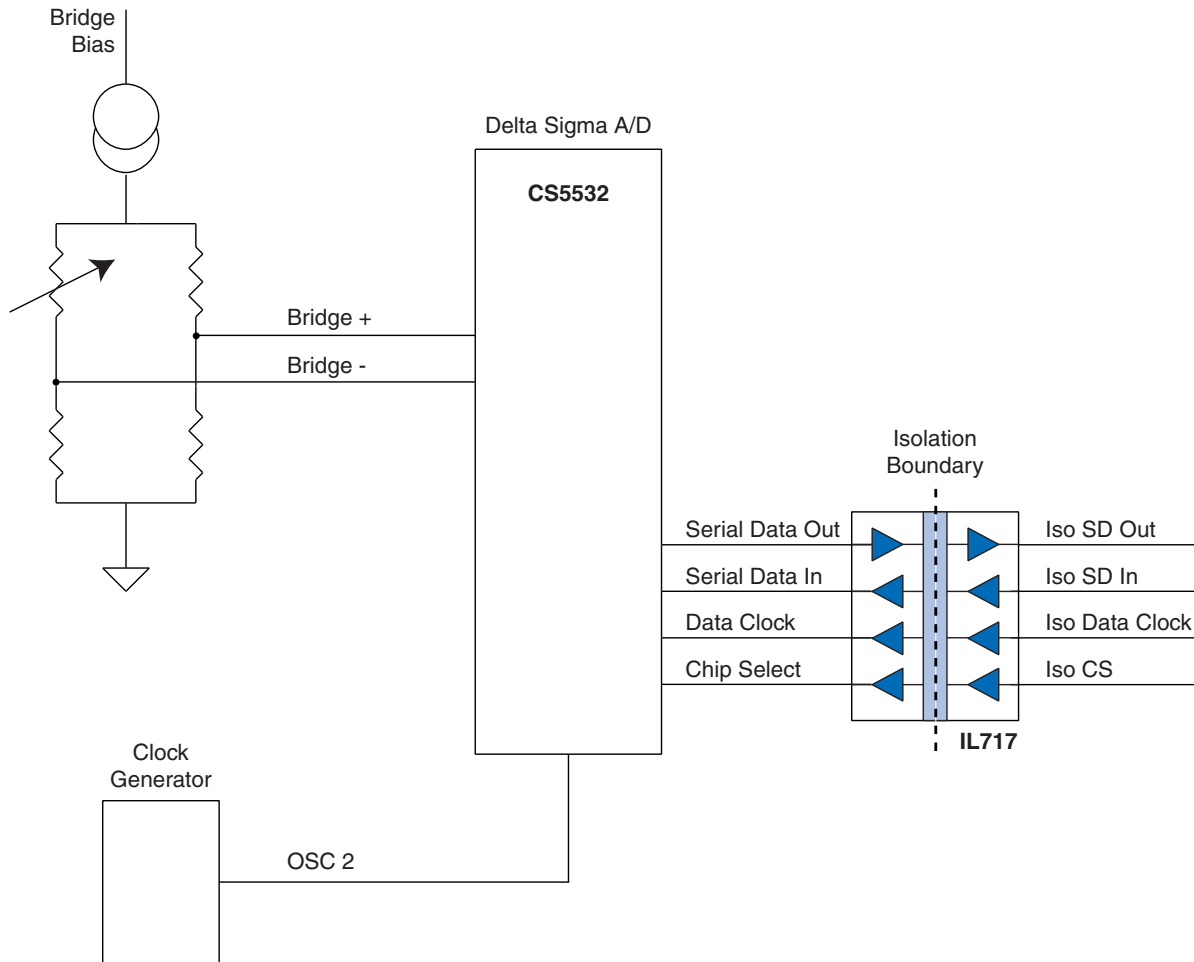

This circuit illustrates a typical single-channel delta-sigma ADC. The A/D is located on the bridge with no signal conditioning electronics between the bridge sensor and the ADC. In this case, the IL717 is the best choice for isolation. It isolates the control bus from the microcontroller. The system clock is located on the isolated side of the system.

Package Drawings

Ultraminiature 16-pin QSOP Package (-1 suffix)

Dimensions in inches (mm); scale = approx. 5X

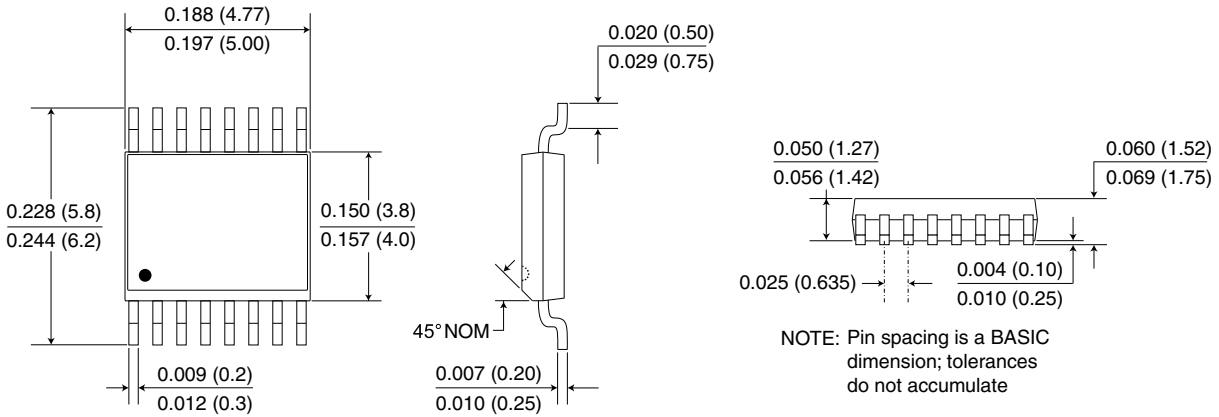

0.15" 16-pin SOIC Package (-3 suffix)

Dimensions in inches (mm); scale = approx. 5X

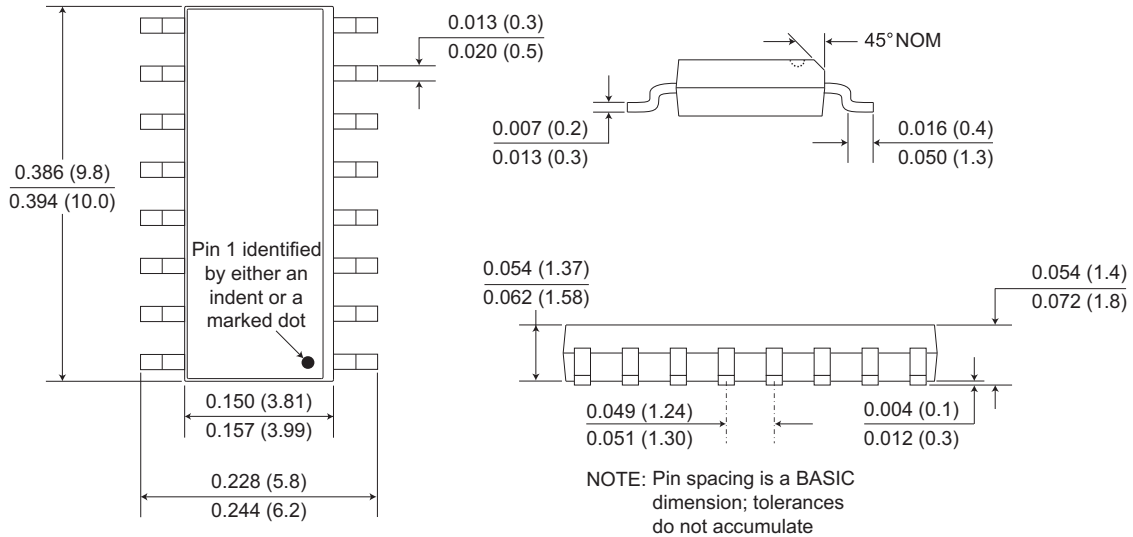

0.3" 16-pin SOIC Package (no suffix)

Dimensions in inches (mm); scale = approx. 5X

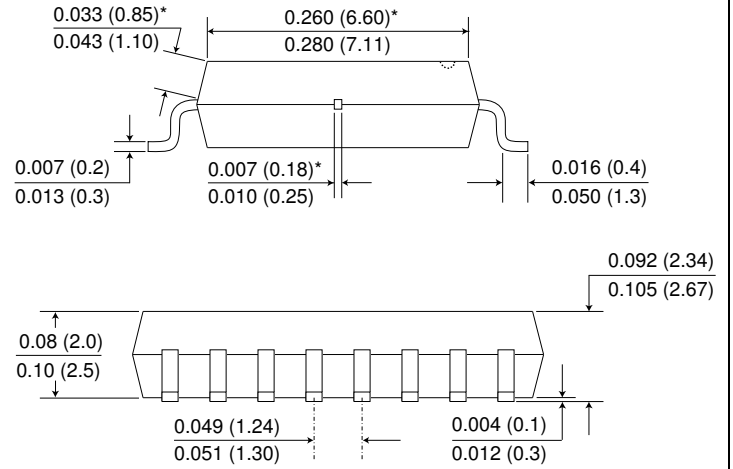
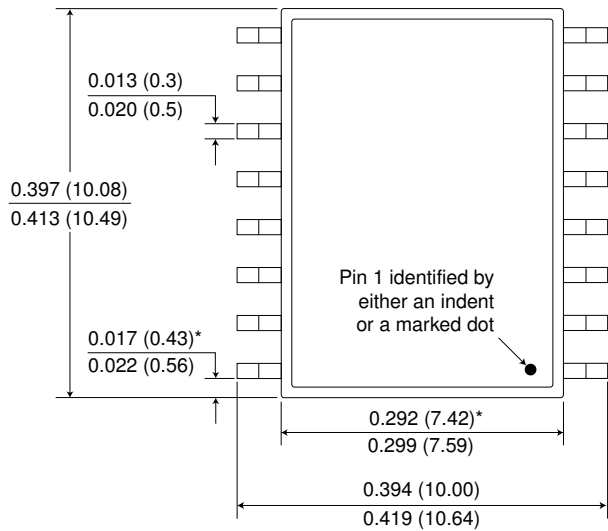

NOTE: Pin spacing is a BASIC dimension; tolerances do not accumulate

*Specified for True 8™ package to guarantee 8 mm creepage per IEC 60601.

Recommended Pad Layouts

4 mm x 5 mm 16-pin QSOP Pad Layout

Dimensions in inches (mm); scale = approx. 5X

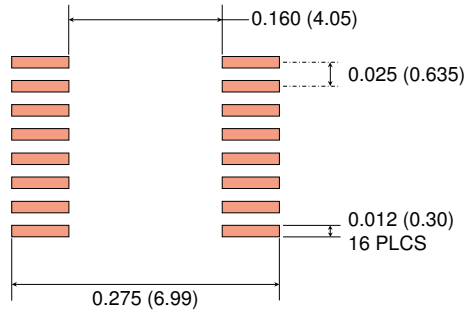

0.15" 16-pin SOIC Pad Layout

Dimensions in inches (mm); scale = approx. 5X

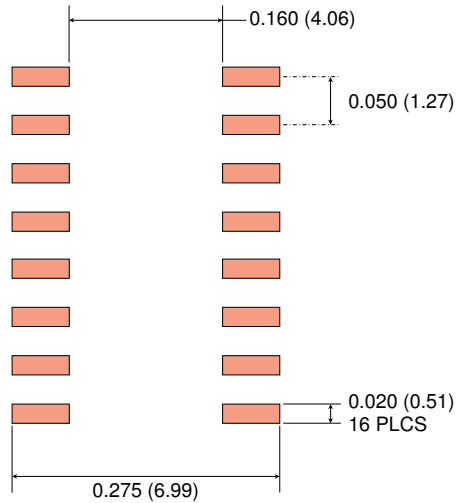

0.3" 16-pin SOIC Pad Layout

Dimensions in inches (mm); scale = approx. 5X

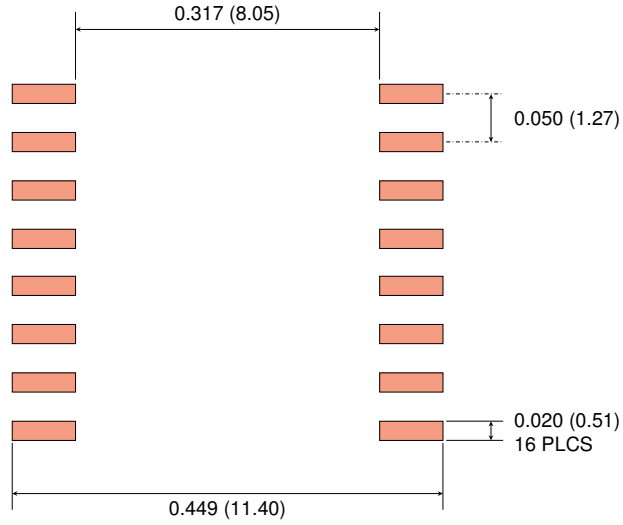

Ordering Information

IL 716 T - 3 E TR13

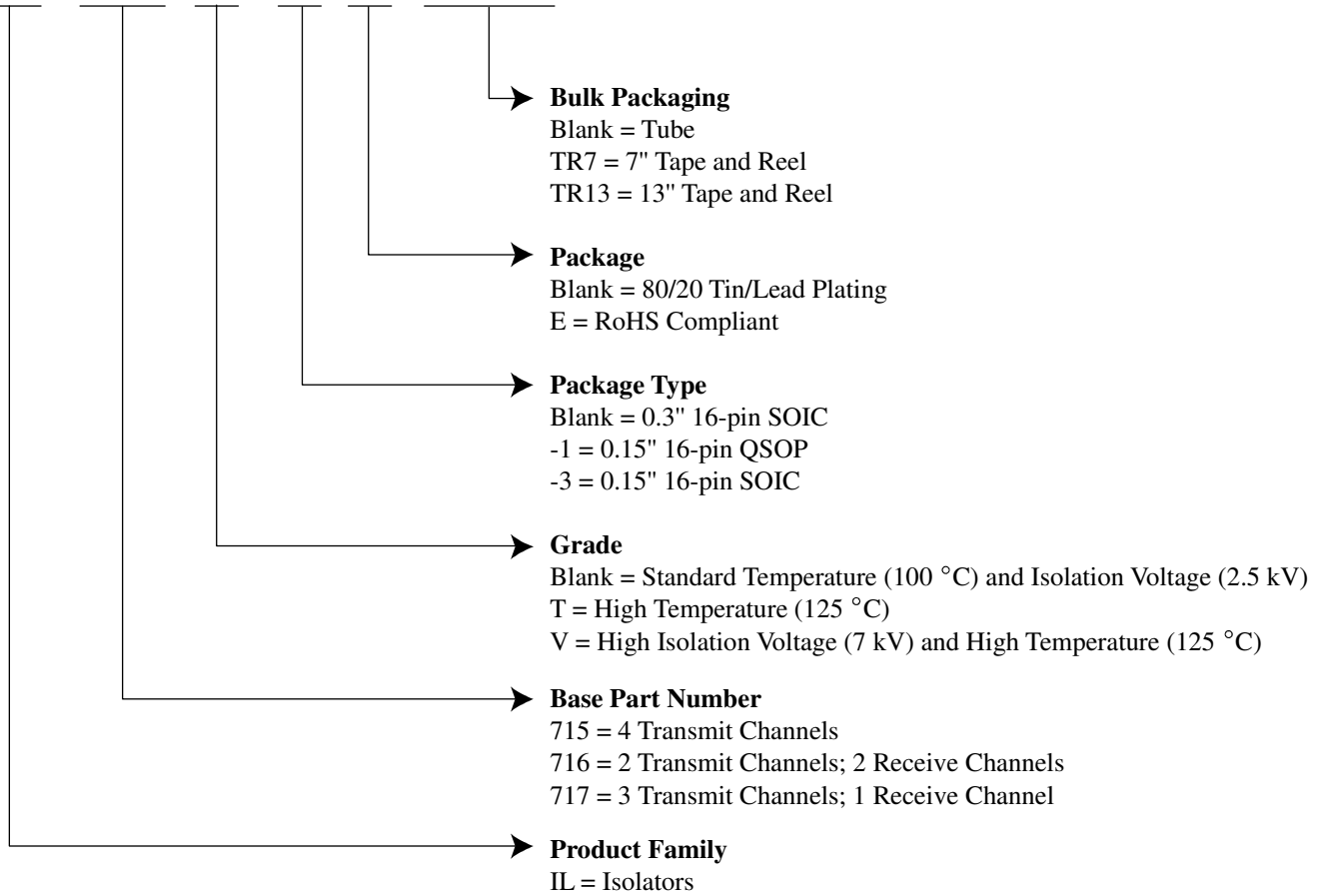

Available Parts

Available Parts	Transmit Channels	Receive Channels	Maximum Temperature	Isolation Voltage (RMS)	Package	RoHS
IL715-1E	4	0	100°C	2.5 kV	QSOP	Y
IL715-3	4	0	100°C	2.5 kV	Narrow SOIC	N
IL715-3E	4	0	100°C	2.5 kV	Narrow SOIC	Y
IL715	4	0	100°C	2.5 kV	Wide SOIC	N
IL715E	4	0	100°C	2.5 kV	Wide SOIC	Y
IL715T-3	4	0	125°C	2.5 kV	Narrow SOIC	N
IL715T-3E	4	0	125°C	2.5 kV	Narrow SOIC	Y
IL715T	4	0	125°C	2.5 kV	Wide SOIC	N
IL715TE	4	0	125°C	2.5 kV	Wide SOIC	Y
IL715VE	4	0	125°C	7 kV	Wide SOIC	Y
IL716-1E	2	2	100°C	2.5 kV	QSOP	Y
IL716-3	2	2	100°C	2.5 kV	Narrow SOIC	N
IL716-3E	2	2	100°C	2.5 kV	Narrow SOIC	Y
IL716	2	2	100°C	2.5 kV	Wide SOIC	N
IL716E	2	2	100°C	2.5 kV	Wide SOIC	Y
IL716T-3	2	2	125°C	2.5 kV	Narrow SOIC	N
IL716T-3E	2	2	125°C	2.5 kV	Narrow SOIC	Y
IL716T	2	2	125°C	2.5 kV	Wide SOIC	N
IL716TE	2	2	125°C	2.5 kV	Wide SOIC	Y
IL716VE	2	2	125°C	7 kV	Wide SOIC	Y
IL717-1E	3	1	100°C	2.5 kV	QSOP	Y
IL717-3	3	1	100°C	2.5 kV	Narrow SOIC	N
IL717-3E	3	1	100°C	2.5 kV	Narrow SOIC	Y
IL717	3	1	100°C	2.5 kV	Wide SOIC	N
IL717E	3	1	100°C	2.5 kV	Wide SOIC	Y
IL717T-3	3	1	125°C	2.5 kV	Narrow SOIC	N
IL717T-3E	3	1	125°C	2.5 kV	Narrow SOIC	Y
IL717T	3	1	125°C	2.5 kV	Wide SOIC	N
IL717TE	3	1	125°C	2.5 kV	Wide SOIC	Y
IL717VE	3	1	125°C	7 kV	Wide SOIC	Y

All part types are available on tape and reel.

ISB-DS-001-IL715/6/7-AL
April 2024

Change

- Changed V-Series minimum supply specification from 2.7 V to 2.95 V (p. 2), lot codes ≥ 240900 .

ISB-DS-001-IL715/6/7-AK

Change

- Upgraded to IEC 60747-17 (VDE 0884-17):2021-10 (p. 3).

ISB-DS-001-IL715/6/7-AJ

Change

- Increased V-Series isolation specification from 6 kVrms to 7 kVRMS (9.9 kVpk), lot codes ≥ 240900 .

ISB-DS-001-IL715/6/7-AI

Changes

- Upgraded to IEC 60747-17 (VDE 0884-17):2021-10 (p. 3).
- Increased Working Voltage ratings based on latest VDE testing (p. 3).
- Added “VE” version ATEX / IEC 60079 certification for intrinsically safe applications (p. 3).

ISB-DS-001-IL715/6/7-AH

Changes

- Upgraded CMTI specifications.
- Added ATEX / IEC 60079 Intrinsic Safety pending (p. 3).
- Added output-side dynamic current specifications (pp. 6 and 7).

ISB-DS-001-IL715/6/7-AG

Changes

- Added degree symbol to temperatures on p. 17.
- Deleted redundant parts list table on p. 17.
- Corrected three incorrect RoHS designations in table on p. 18.

ISB-DS-001-IL715/6/7-AF

Changes

- Extended minimum operating power supply to 2.7 volts.
- Explicitly listed part types for max. operating temperatures.
- Updated EMC standards.
- Deleted minimum magnetic field immunity specifications since it is not 100% tested.
- Revised thermal characteristics.
- Added Typical Performance Graphs.
- More detailed description of operation.

ISB-DS-001-IL715/6/7-AE

Change

- Updated VDE Reinforced Isolation file number and description.

ISB-DS-001-IL715/6/7-AD

Changes

- Clarified 600 V CTI specification is for 0.3" SOIC only (p. 2).
- Corrected typographical error in “Available Parts” table (p. 15).

ISB-DS-001-IL715/6/7-AC

Changes

- Updated VDE certification standard to VDE V 0884-10.
- Upgraded “V” Version Surge Immunity specification to 12.8 kV.
- Upgraded “V” Version VDE 0884-10 rating to reinforced insulation.
- Corrected QSOP pin width dimension (p. 10).

ISB-DS-001-IL715/6/7-AB

Changes

- Increased V-Series isolation voltage to 6 kVrms.
- Increased typ. Total Barrier Thickness specification to 0.016 mm.
- Increased CTI min. specification to ≥ 600 Vrms.

ISB-DS-001-IL715/6/7-AA

Changes

- Added V-Series 5 kV isolation voltage versions.
- More detailed “Available Parts” table.

Datasheet Limitations

The information and data provided in datasheets shall define the specification of the product as agreed between NVE and its customer, unless NVE and customer have explicitly agreed otherwise in writing. All specifications are based on NVE test protocols. In no event however, shall an agreement be valid in which the NVE product is deemed to offer functions and qualities beyond those described in the datasheet.

Limited Warranty and Liability

Information in this document is believed to be accurate and reliable. However, NVE does not give any representations or warranties, expressed or implied, as to the accuracy or completeness of such information and shall have no liability for the consequences of use of such information.

In no event shall NVE be liable for any indirect, incidental, punitive, special or consequential damages (including, without limitation, lost profits, lost savings, business interruption, costs related to the removal or replacement of any products or rework charges) whether or not such damages are based on tort (including negligence), warranty, breach of contract or any other legal theory.

Right to Make Changes

NVE reserves the right to make changes to information published in this document including, without limitation, specifications and product descriptions at any time and without notice. This document supersedes and replaces all information supplied prior to its publication.

Use in Life-Critical or Safety-Critical Applications

Unless NVE and a customer explicitly agree otherwise in writing, NVE products are not designed, authorized or warranted to be suitable for use in life support, life-critical or safety-critical devices or equipment. NVE accepts no liability for inclusion or use of NVE products in such applications and such inclusion or use is at the customer's own risk. Should the customer use NVE products for such application whether authorized by NVE or not, the customer shall indemnify and hold NVE harmless against all claims and damages.

Applications

Applications described in this datasheet are illustrative only. NVE makes no representation or warranty that such applications will be suitable for the specified use without further testing or modification.

Customers are responsible for the design and operation of their applications and products using NVE products, and NVE accepts no liability for any assistance with applications or customer product design. It is customer's sole responsibility to determine whether the NVE product is suitable and fit for the customer's applications and products planned, as well as for the planned application and use of customer's third party customers. Customers should provide appropriate design and operating safeguards to minimize the risks associated with their applications and products.

NVE does not accept any liability related to any default, damage, costs or problem which is based on any weakness or default in the customer's applications or products, or the application or use by customer's third party customers. The customer is responsible for all necessary testing for the customer's applications and products using NVE products in order to avoid a default of the applications and the products or of the application or use by customer's third party customers. NVE accepts no liability in this respect.

Limiting Values

Stress above one or more limiting values (as defined in the Absolute Maximum Ratings System of IEC 60134) will cause permanent damage to the device. Limiting values are stress ratings only and operation of the device at these or any other conditions above those given in the recommended operating conditions of the datasheet is not warranted. Constant or repeated exposure to limiting values will permanently and irreversibly affect the quality and reliability of the device.

Terms and Conditions of Sale

In case an individual agreement is concluded only the terms and conditions of the respective agreement shall apply. NVE hereby expressly objects to applying the customer's general terms and conditions with regard to the purchase of NVE products by customer.

No Offer to Sell or License

Nothing in this document may be interpreted or construed as an offer to sell products that is open for acceptance or the grant, conveyance or implication of any license under any copyrights, patents or other industrial or intellectual property rights.

Export Control

This document as well as the items described herein may be subject to export control regulations. Export might require a prior authorization from national authorities.

Automotive Qualified Products

Unless the datasheet expressly states that a specific NVE product is automotive qualified, the product is not suitable for automotive use. It is neither qualified nor tested in accordance with automotive testing or application requirements. NVE accepts no liability for inclusion or use of non-automotive qualified products in automotive equipment or applications.

In the event that customer uses the product for design-in and use in automotive applications to automotive specifications and standards, customer (a) shall use the product without NVE's warranty of the product for such automotive applications, use and specifications, and (b) whenever customer uses the product for automotive applications beyond NVE's specifications such use shall be solely at customer's own risk, and (c) customer fully indemnifies NVE for any liability, damages or failed product claims resulting from customer design and use of the product for automotive applications beyond NVE's standard warranty and NVE's product specifications.

An ISO 9001 Certified Company

NVE Corporation
11409 Valley View Road
Eden Prairie, MN 55344-3617 USA
Telephone: (952) 829-9217

www.nve.com
e-mail: iso-info@nve.com

©NVE Corporation
All rights are reserved. Reproduction in whole or in part is prohibited without the prior written consent of the copyright owner.

ISB-DS-001-IL715/6/7-AL

April 2024

Looking for pricing, stock, or lifecycle information?

Click below to explore more details on WIN SOURCE:

 [View IL 717ETR13 on WIN SOURCE](#)

 [NVE Corp Information](#)

Optimize Your Supply Chain with WIN SOURCE Solutions

-  Global Sourcing Solution
-  Obsolete Management
-  Cost Control Management
-  Shortage Management
-  Alternative Solution
-  Excess Inventory Management