



THE DATASHEET OF CSPT855PGGI8



FEATURES:

- PLL clock driver for DDR (Double Data Rate) synchronous DRAM applications
- Spread spectrum clock compatible
- Operating frequency: 60MHz to 220MHz
- Low jitter (cycle-to-cycle): $\pm 50\text{ps}$
- Distributes one differential clock input to four differential clock outputs
- Enters low power mode and 3-state outputs when input CLK signal is less than 20MHz or PWRDWN is low
- Operates from a 2.5V supply
- Consumes $<200\mu\text{A}$ quiescent current
- External feedback pins (FBIN, $\overline{\text{FBIN}}$) are used to synchronize outputs to input clocks
- Available in TSSOP package

APPLICATIONS:

- For all DDR1 speeds: PC1600 (DDR200), PC2100 (DDR266), PC2700 (DDR333), PC3200 (DDR400)

DESCRIPTION:

The CSPT855 is a high-performance, low-skew, low-jitter zero delay buffer that distributes one differential clock input pair (CLK, $\overline{\text{CLK}}$) to four differential output pairs (Y[0:3], $\overline{\text{Y[0:3]}}$) and one differential pair of feedback clock outputs (FBOUT, $\overline{\text{FBOUT}}$). When $\overline{\text{PWRDWN}}$ is high, the outputs switch in phase and frequency with CLK. When $\overline{\text{PWRDWN}}$ is low, all outputs are disabled to a high-impedance state (3-state), and the PLL is shut down (low-power mode). The device also enters this low-power mode when the input frequency falls below a suggested detection frequency that is below 20MHz (typical 10MHz). An input frequency detection circuit detects the low-frequency condition, and after applying a $>20\text{MHz}$ input signal, this detection circuit reactivates the PLL and enables the outputs.

When AV_{DD} is tied to GND, the PLL is turned off and bypassed for test purposes. The CSPT855 is also able to track spread spectrum clocking for reduced EMI.

Since the CSPT855 is based on PLL circuitry, it requires a stabilization time to achieve phase-lock of the PLL. This stabilization time is required following power up.

FUNCTIONAL BLOCK DIAGRAM

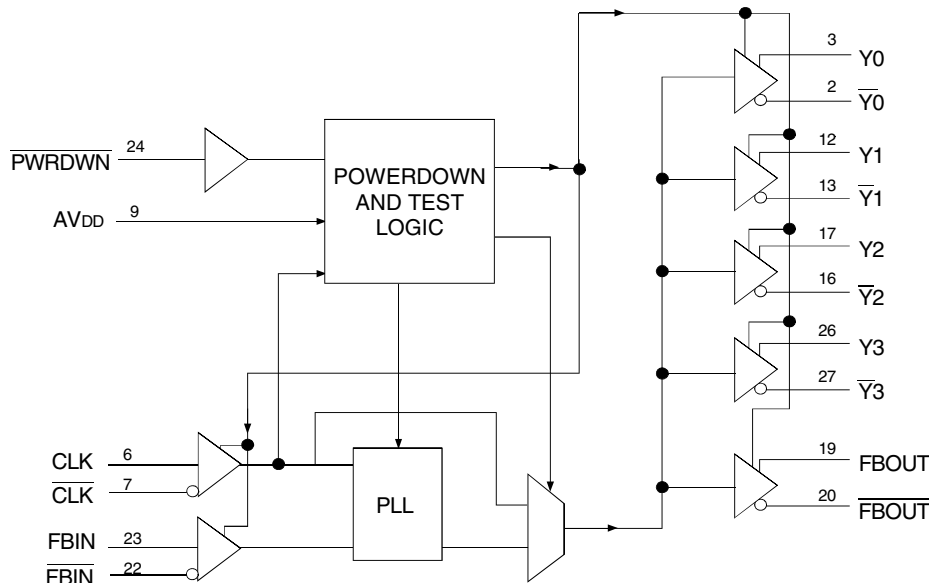

PIN CONFIGURATION

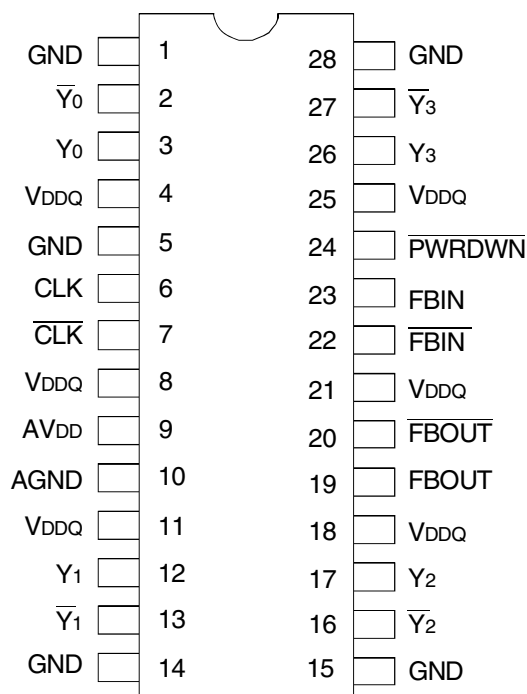

TSSOP
TOP VIEW

ABSOLUTE MAXIMUM RATINGS⁽¹⁾

Symbol	Rating	Max	Unit
V _{DDQ} , AV _{DD}	Supply Voltage Range	-0.5 to +3.6	V
V _I ⁽²⁾	Input Voltage Range	-0.5 to V _{DDQ} + 0.5	V
V _O ⁽²⁾	Output Voltage Range	-0.5 to V _{DDQ} + 0.5	V
I _{IK} (V _I < 0 or V _I < V _{DDQ})	Input Clamp Current	±50	mA
I _{OK} (V _O < 0 or V _O > V _{DDQ})	Output Clamp Current	±50	mA
I _O (V _O = 0 to V _{DDQ})	Continuous Output Current	±50	mA
V _{DDQ} or GND	Continuous Current	±100	mA
θ _{JA} ⁽³⁾	Package Thermal Impedance	105.8	°C/W
T _{STG}	Storage Temperature Range	-65 to +150	°C

NOTES:

- Stresses greater than those listed under ABSOLUTE MAXIMUM RATINGS may cause permanent damage to the device. This is a stress rating only and functional operation of the device at these or any other conditions above those indicated in the operational sections of this specification is not implied. Exposure to absolute maximum rating conditions for extended periods may affect reliability.
- The input and output negative-voltage ratings may be exceeded if the input and output clamp-current ratings are observed. This value is limited to 3.6V maximum.
- The package thermal impedance is calculated in accordance with JEDEC 51.

PIN DESCRIPTION

Pin Name	Pin Number	I/O	Description
AGND	10		Ground for analog supply
AV _{DD}	9		Analog supply
CLK, CLK-bar	6, 7	I	Differential clock input
FBIN-bar, FBIN	22, 23	I	Feedback differential clock input
FBOUT, FBOUT-bar	19, 20	O	Feedback differential clock output
GND	1, 5, 14, 15, 28		Ground
PWRDWN	24	I	Control input to turn device in the power-down mode
V _{DDQ}	4, 8, 11, 18, 21, 25		I/O supply
Y _[0:3]	3, 12, 17, 26	O	Buffered output copies of input clock, CLK
Y _[0:3] -bar	2, 13, 16, 27	O	Buffered output copies of input clock, CLK-bar

FUNCTION TABLE⁽¹⁾

INPUTS				OUTPUTS				
AVDD	PWRDWN	CLK	CLK	Y	Y	FBOU	FBOU	PLL
GND	H	L	H	L	H	L	H	Bypassed/OFF
GND	H	H	L	H	L	H	L	Bypassed/OFF
X	L	L	H	Z	Z	Z	Z	OFF
X	L	H	L	Z	Z	Z	Z	OFF
2.5V (nom)	H	L	H	L	H	L	H	ON
2.5V (nom)	H	H	L	H	L	H	L	ON
2.5V (nom)	X	<20MHz ⁽²⁾	<20MHz ⁽²⁾	Z	Z	Z	Z	OFF

NOTES:

- H = HIGH Voltage Level
L = LOW Voltage Level
Z = High-Impedance OFF-State
X = Don't Care
- Typically 10MHz.

RECOMMENDED OPERATING CONDITIONS⁽¹⁾

Symbol	Parameter		Min.	Typ.	Max.	Unit
AVDD, VDDQ	Supply Voltage		2.3	—	2.7	V
VIL	Input Voltage LOW	CLK, CLK, FBIN, FBIN	—	—	VDDQ/2 - 0.18	V
		PWRDWN	-0.3	—	0.7	
VIH	Input Voltage HIGH	CLK, CLK, FBIN, FBIN	VDDQ/2 + 0.18	—	—	V
		PWRDWN	1.7	—	VDDQ + 0.3	
	DC Input Signal Voltage ⁽²⁾		-0.3	—	VDDQ	V
VID	Differential Input Signal Voltage ⁽³⁾	CLK, FBIN	0.36	—	VDDQ + 0.6	V
VO(X)	Output Differential Cross-Voltage ⁽⁴⁾		VDDQ/2 - 0.2	VDDQ/2	VDDQ/2 + 0.2	V
VI(X)	Input Differential Pair Cross-Voltage ⁽⁴⁾		VDDQ/2 - 0.2	—	VDDQ/2 + 0.2	V
IOH	HIGH-Level Output Current		—	—	-12	mA
IoL	LOW-Level Output Current		—	—	12	mA
SR	Input Slew Rate, see figure 8		1	—	4	V/ns
TA	Operating Free-Air Temperature	Commercial	0	—	+70	°C
		Industrial	-40	—	+85	

NOTES:

- Unused inputs must be held HIGH or LOW to prevent them from floating.
- DC input signal voltage specifies the allowable DC execution of differential input.
- Differential input signal voltage specifies the differential voltage $|V_{TR} - V_{CP}|$ required for switching, where V_{TR} is the true input level and V_{CP} is the complementary input level.
- Differential cross-point voltage is expected to track variations of V_{DDQ} and is the voltage at which the differential signals must be crossing.

DC ELECTRICAL CHARACTERISTICS OVER OPERATING RANGE

Following Conditions Apply Unless Otherwise Specified:

Commercial: TA = 0°C to +70°C; Industrial: TA = -40°C to +85°C

Symbol	Parameter	Conditions	Min.	Typ. ⁽¹⁾	Max.	Unit	
V _{IK}	Input Voltage (All Inputs)	V _{DDQ} = 2.3V, I _I = -18mA	—	—	-1.2	V	
V _{OH}	HIGH-Level Output Voltage	V _{DDQ} = Min. to Max., I _{OH} = -1mA	V _{DDQ} - 0.1	—	—	V	
		V _{DDQ} = 2.3V, I _{OH} = -12mA	1.7	—	—		
V _{OL}	LOW-Level Output Voltage	V _{DDQ} = Min. to Max., I _{OL} = 1mA	—	—	0.1	V	
		V _{DDQ} = 2.3V, I _{OL} = 12mA	—	—	0.6		
I _{OH}	HIGH-Level Output Current	V _{DDQ} = 2.3V, V _O = 1V	-18	-32	—	mA	
I _{OL}	LOW-Level Output Current	V _{DDQ} = 2.3V, V _O = 1.2V	26	35	—	mA	
V _{OD}	Output Voltage Swing	Differential outputs are terminated with 120Ω	1.1	—	V _{DDQ} - 0.4	V	
V _{OX}	Output Differential Cross Voltage ⁽²⁾	Differential outputs are terminated with 120Ω	V _{DDQ} /2 - 0.2	V _{DDQ} /2	V _{DDQ} /2 + 0.2	V	
I _I	Input Current	V _{DDQ} = 2.7V, V _I = 0V to 2.7V	—	—	±10	μA	
I _{OZ}	High-Impedance State Output Current	V _{DDQ} = 2.7V, V _O = V _{DDQ} or GND	—	—	±10	μA	
I _{DD(PD)}	Power-Down Current on V _{DDQ} and AV _{DD}	CLK and $\overline{\text{CLK}}$ = 0MHz, $\overline{\text{PWRDWN}}$ = LOW, Σ of I _{DD} and I _{ALDD}	—	100	200	μA	
I _{DD}	Dynamic Current on V _{DDQ}	C _L = 14pF	f _o = 167MHz, Differential outputs terminated with 120Ω	—	150	180	mA
		C _L = 0pF	f _o = 167MHz, Differential outputs terminated with 120Ω	—	130	160	
I _{ALDD}	Supply Current on AV _{DD}	f _o = 167MHz	—	8	10	mA	
C _I	Input Capacitance	V _{DDQ} = 2.5V, V _I = V _{DDQ} or GND	2	2.5	3	pF	
C _O	Output Capacitance	V _{DDQ} = 2.5V, V _I = V _{DDQ} or GND	2.5	3	3.5	pF	

NOTES:

- All typical values are at respective nominal V_{DDQ}.
- Differential cross-point voltage is expected to track variation of V_{DDQ} and is the voltage at which the differential signals must be crossing.

TIMING REQUIREMENTS

Symbol	Parameter	Min.	Max.	Unit
f _{CLK}	Operating Clock Frequency	60	220	MHz
t _{DC}	Input Clock Duty Cycle	40	60	%
t _L	Stabilization Time (PLL Mode) ⁽¹⁾	—	10	μs
t _L	Stabilization Time (Bypass Mode) ⁽²⁾	—	30	ns

NOTES:

- Recovery time required when the device goes from power-down mode into bypass mode (test mode with AV_{DD} at GND).
- Time required for the integrated PLL circuit to obtain phase lock of its feedback signal to its reference signal. For phase lock to be obtained, a fixed-frequency, fixed-phase reference signal must be present at CLK. Until phase lock is obtained, the specifications for propagation delay, skew, and jitter parameters given in the switching characteristics table are not applicable. This parameter does not apply for input modulation under SSC application.

SWITCHING CHARACTERISTICS

Symbol	Description	Test Conditions	Min.	Typ. ⁽¹⁾	Max.	Unit	
$t_{PLH}^{(2)}$	LOW to HIGH Level Propagation Delay Time	Test mode, CLK to any output	—	4.5	—	ns	
$t_{PHL}^{(2)}$	HIGH to LOW Level Propagation Delay Time	Test mode, CLK to any output	—	4.5	—	ns	
$t_{JIT(PER)}^{(3)}$	Jitter (period), see figure 6	66MHz	-55	—	55	ps	
		100/ 133/ 167/ 200 MHz	-35	—	35		
$t_{JIT(CC)}^{(3)}$	Jitter (cycle-to-cycle), see figure 2	66MHz	-60	—	60	ps	
		100/ 133/ 167/ 200 MHz	-50	—	50		
$t_{JIT(HPER)}^{(3)}$	Half-Period Jitter, see figure 7	66MHz	-130	—	130	ps	
		100MHz	-90	—	90		
		133/ 167/ 200 MHz	-75	—	75		
$t_{SLR(O)}$	Output Clock Slew Rate (single-ended), see figure 8	Load: 120Ω / 14pF	1	—	2	V/ns	
		Load: 120Ω / 4pF	1	—	3		
$t_{D(\varnothing)}^{(3)}$	Dynamic Phase Offset (includes jitter) see figure 4	SSC Off	66MHz	-180	—	180	ps
			100/ 133 MHz	-130	—	130	
			167/ 200 MHz	-90	—	90	
		SSC On	66MHz	-230	—	230	
			100/ 133 MHz	-170	—	170	
			167/ 200 MHz	-100	—	100	
$t(\varnothing)$	Static Phase Offset, see figure 3	66MHz	-150	—	150	ps	
		100/ 133/ 167 MHz	-100	—	100		
		200MHz	-50	—	50		
$t_{SK(O)}^{(4)}$	Output Skew, see figure 5		—	—	50	ps	
t_R, t_F	Output Rise and Fall Times (20% to 80%)	Load: 120Ω / 14pF	650	—	900	ps	

NOTES:

1. All typical values are at respective nominal V_{DDO} .
2. Refers to transition of non-inverting output.
3. This parameter guaranteed by design but not production tested.
4. All differential output pins are terminated with 120Ω / 14pF.

TEST CIRCUIT AND SWITCHING WAVEFORMS

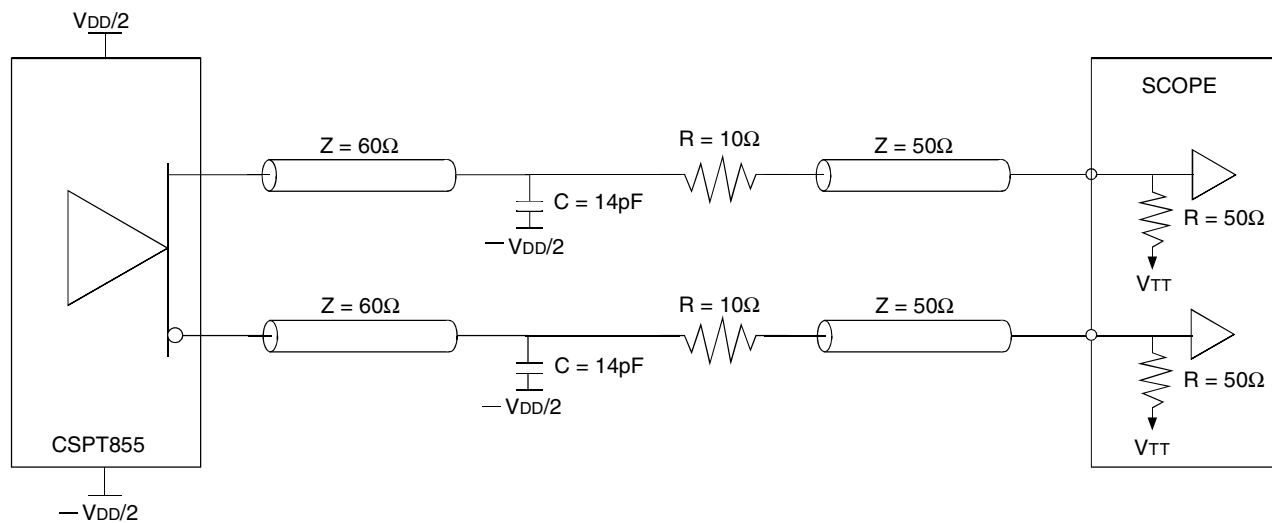

NOTE:
1. $V_{TT} = GND$

Figure 1. Output Load Test Circuit

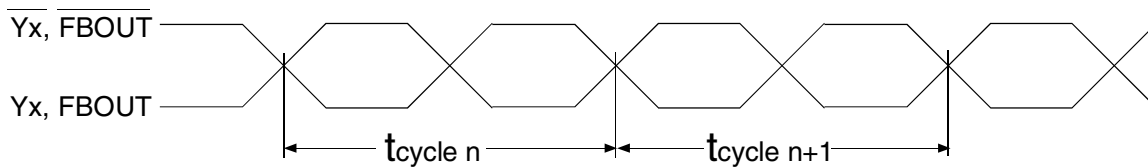

$$t_{jit(cc)} = t_{cycle\ n} - t_{cycle\ n+1}$$

Figure 2. Cycle-to-Cycle jitter

TEST CIRCUIT AND SWITCHING WAVEFORMS

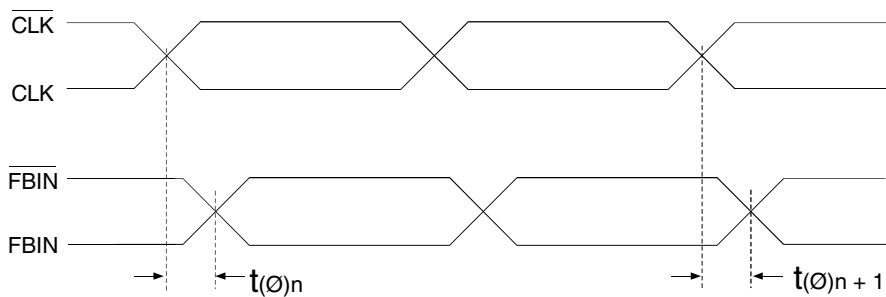

$$t(\phi) = \frac{\sum_{n=1}^{n=N} t(\phi)_n}{N}$$

(N is a large number of samples)

Figure 3. Static Phase Offset

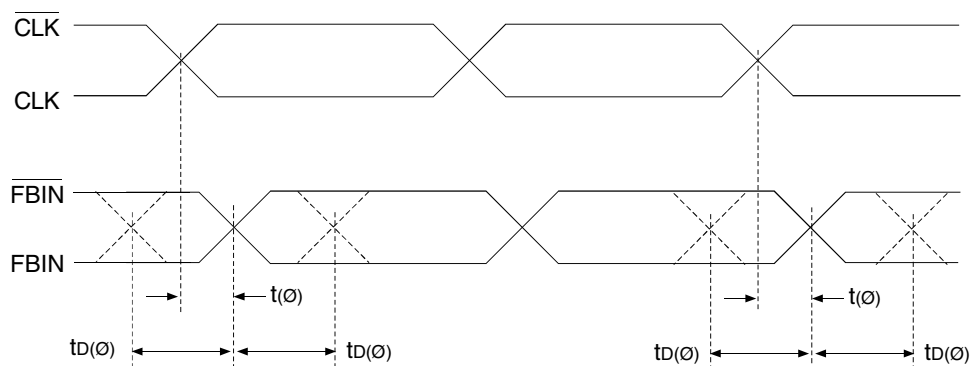

Figure 4. Dynamic Phase Offset

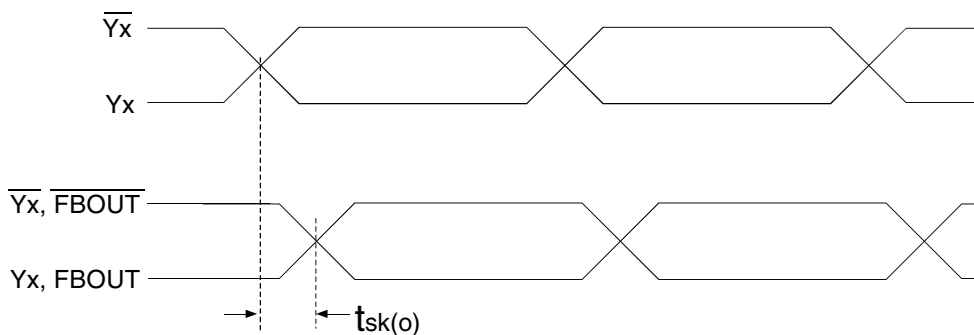
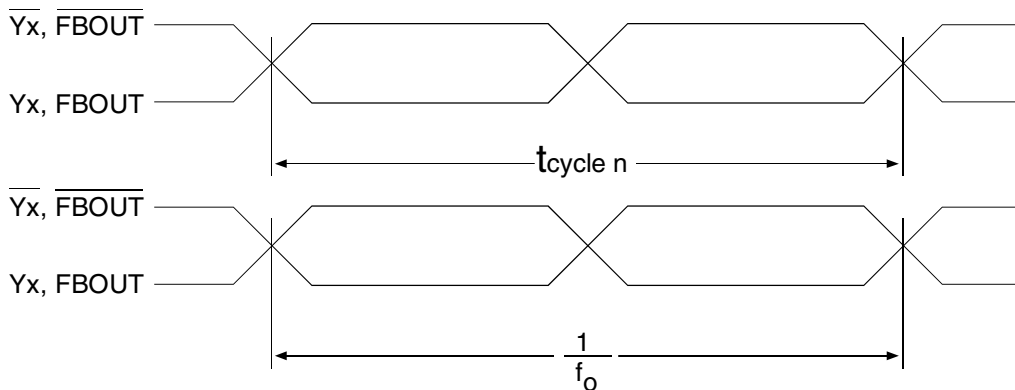

Figure 5. Output Skew

TEST CIRCUIT AND SWITCHING WAVEFORMS



$$t_{\text{jit(per)}} = t_{\text{cycle } n} - \frac{1}{f_0}$$

Figure 6. Period jitter

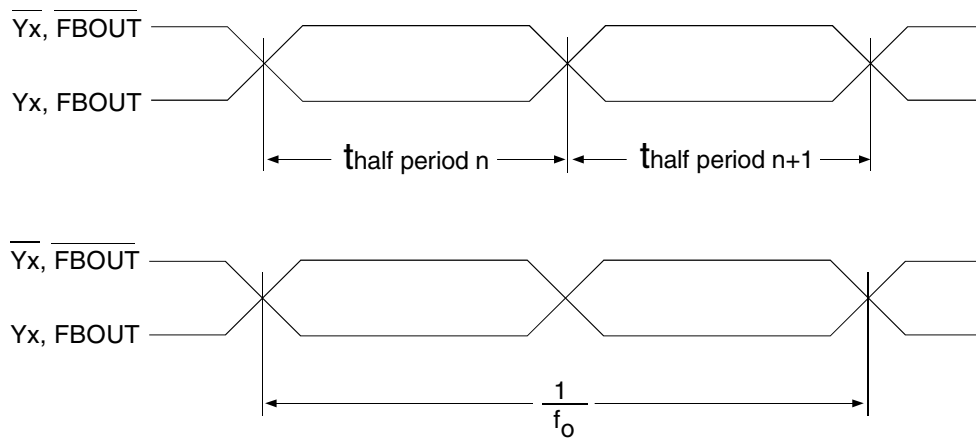

$$t_{\text{jit(hper)}} = t_{\text{half period } n} - \frac{1}{2 \cdot f_0}$$

Figure 7. Half-Period jitter

TEST CIRCUIT AND SWITCHING WAVEFORMS



Figure 8. Input and Output Slew Rates

ORDERING INFORMATION

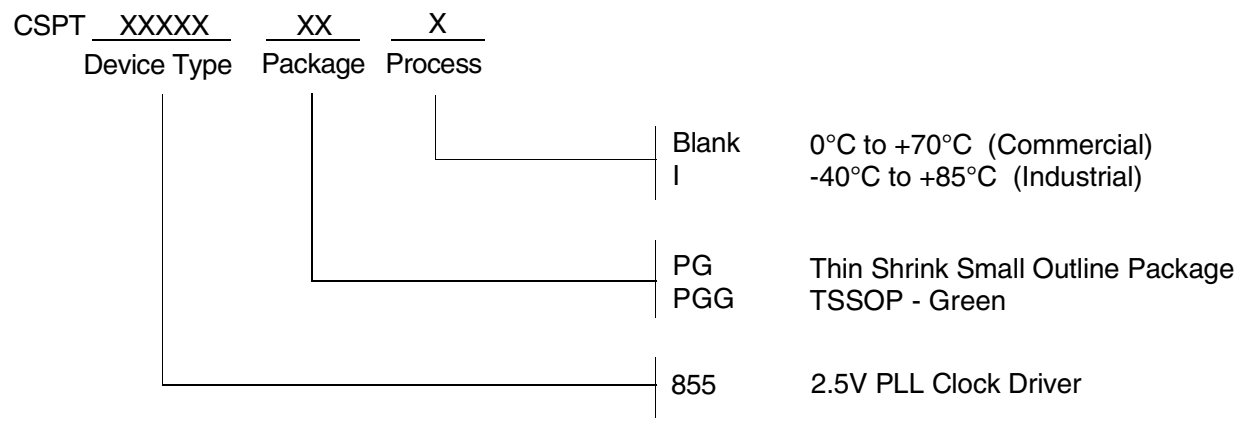

IMPORTANT NOTICE AND DISCLAIMER

RENESAS ELECTRONICS CORPORATION AND ITS SUBSIDIARIES (“RENESAS”) PROVIDES TECHNICAL SPECIFICATIONS AND RELIABILITY DATA (INCLUDING DATASHEETS), DESIGN RESOURCES (INCLUDING REFERENCE DESIGNS), APPLICATION OR OTHER DESIGN ADVICE, WEB TOOLS, SAFETY INFORMATION, AND OTHER RESOURCES “AS IS” AND WITH ALL FAULTS, AND DISCLAIMS ALL WARRANTIES, EXPRESS OR IMPLIED, INCLUDING, WITHOUT LIMITATION, ANY IMPLIED WARRANTIES OF MERCHANTABILITY, FITNESS FOR A PARTICULAR PURPOSE, OR NON-INFRINGEMENT OF THIRD-PARTY INTELLECTUAL PROPERTY RIGHTS.

These resources are intended for developers who are designing with Renesas products. You are solely responsible for (1) selecting the appropriate products for your application, (2) designing, validating, and testing your application, and (3) ensuring your application meets applicable standards, and any other safety, security, or other requirements. These resources are subject to change without notice. Renesas grants you permission to use these resources only to develop an application that uses Renesas products. Other reproduction or use of these resources is strictly prohibited. No license is granted to any other Renesas intellectual property or to any third-party intellectual property. Renesas disclaims responsibility for, and you will fully indemnify Renesas and its representatives against, any claims, damages, costs, losses, or liabilities arising from your use of these resources. Renesas' products are provided only subject to Renesas' Terms and Conditions of Sale or other applicable terms agreed to in writing. No use of any Renesas resources expands or otherwise alters any applicable warranties or warranty disclaimers for these products.

(Disclaimer Rev.1.01 Jan 2024)

Corporate Headquarters

TOYOSU FORESIA, 3-2-24 Toyosu,
Koto-ku, Tokyo 135-0061, Japan
www.renesas.com

Trademarks

Renesas and the Renesas logo are trademarks of Renesas Electronics Corporation. All trademarks and registered trademarks are the property of their respective owners.

Contact Information

For further information on a product, technology, the most up-to-date version of a document, or your nearest sales office, please visit www.renesas.com/contact-us/.

Looking for pricing, stock, or lifecycle information?

Click below to explore more details on WIN SOURCE:

- ⊖ [View CSPT855PGGI8 on WIN SOURCE](#)
- ⊖ [Renesas Electronics America](#) Information

Optimize Your Supply Chain with WIN SOURCE Solutions

- ✓ Global Sourcing Solution
- ✓ Obsolete Management
- ✓ Cost Control Management
- ✓ Shortage Management
- ✓ Alternative Solution
- ✓ Excess Inventory Management