



THE DATASHEET OF
5V41066PGGI8



Recommended Applications

4 Output synthesizer for PCIe Gen1/2

General Description

The IDT5V41066 is a PCIe Gen2 compliant spread-spectrum-capable clock generator. The device has 4 differential HCSL outputs and can be used in communication or embedded systems to substantially reduce electro-magnetic interference (EMI). The spread amount and output frequency are selectable via select pins.

Output Features

- 4 - 0.7V current mode differential HCSL output pairs

Features/Benefits

- 20-pin TSSOP package; small board footprint
- Spread-spectrum capable; reduces EMI
- Outputs can be terminated to LVDS; can drive a wider variety of devices
- Power down pin; greater system power management
- OE control pin; greater system power management
- Spread% and frequency pin selection; no software required to configure device
- Industrial temperature range available; supports demanding embedded applications
- **For PCIe Gen3 applications, see the 5V41236**

Key Specifications

- Cycle-to-cycle jitter < 100 ps
- Output-to-output skew < 50 ps
- PCIe Gen2 phase jitter < 3.0ps RMS

Block Diagram

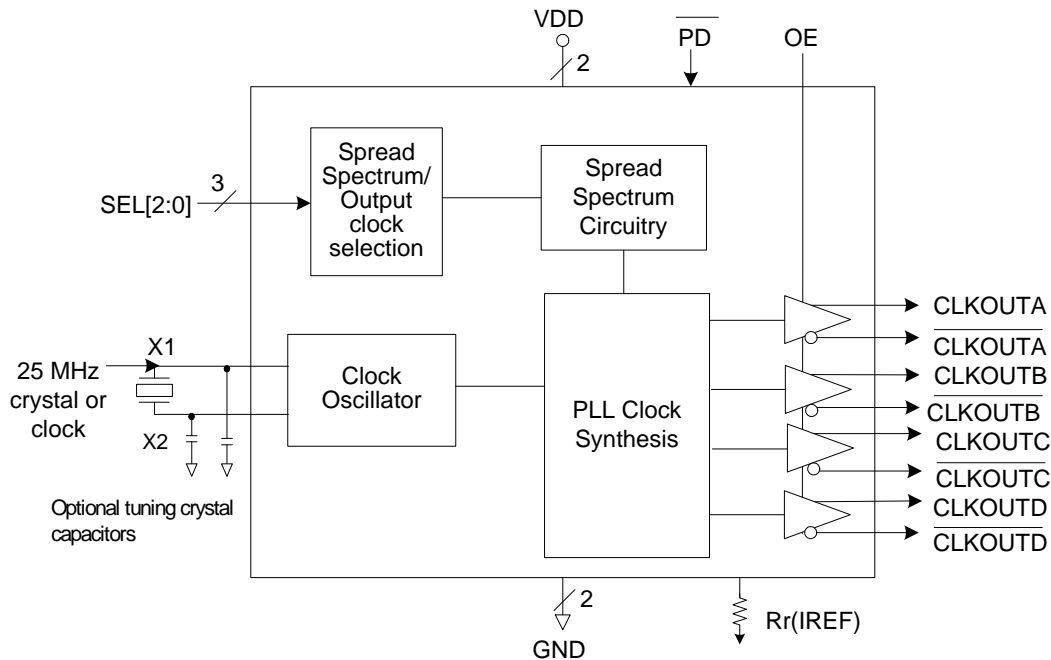

Pin Assignment

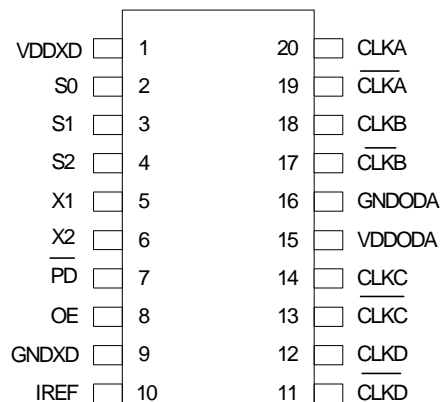

20-pin (173 mil) TSSOP

Spread Spectrum Selection Table

S2	S1	S0	Spread%	Spread Type	Output Frequency
0	0	0	-0.5	Down	100
0	0	1	-1.0	Down	100
0	1	0	-1.5	Down	100
0	1	1	No Spread	Not Applicable	100
1	0	0	-0.5	Down	200
1	0	1	-1.0	Down	200
1	1	0	-1.5	Down	200
1	1	1	No Spread	Not Applicable	200

Pin Descriptions

Pin	Pin Name	Pin Type	Pin Description
1	VDDXD	Power	Connect to +3.3 V digital supply.
2	S0	Input	Spread spectrum select pin #0. See table above. Internal pull-up resistor.
3	S1	Input	Spread spectrum select pin #1. See table above. Internal pull-up resistor.
4	S2	Input	Spread spectrum select pin #2. See table above. Internal pull-up resistor.
5	X1	Input	Crystal connection. Connect to a fundamental mode crystal or clock input.
6	X2	Output	Crystal connection. Connect to a fundamental mode crystal or leave open.
7	PD	Input	Powers down all PLL's and tri-states outputs when low. Internal pull-up resistor.
8	OE	Input	Provides output on, tri-states output (High = enable outputs; Low = disable outputs). Internal pull-up resistor.
9	GND	Power	Connect to digital ground.
10	IREF	Output	Precision resistor attached to this pin is connected to the internal current reference.
11	CLKD	Output	Selectable 100/200 MHz spread spectrum differential Complement output clock D.
12	CLKD	Output	Selectable 100/200 MHz spread spectrum differential True output clock D.
13	CLKC	Output	Selectable 100/200 MHz spread spectrum differential Complement output clock C.
14	CLKC	Output	Selectable 100/200 MHz spread spectrum differential True output clock C.
15	VDDODA	Power	Connect to +3.3 V analog supply.
16	GND	Power	Connect to analog ground.
17	CLKB	Output	Selectable 100/200 MHz spread spectrum differential Complement output clock B.
18	CLKB	Output	Selectable 100/200 MHz spread spectrum differential True output clock B.
19	CLKA	Output	Selectable 100/200 MHz spread spectrum differential Complement output clock A.
20	CLKA	Output	Selectable 100/200 MHz spread spectrum differential True output clock A.

Application Information

Decoupling Capacitors

As with any high-performance mixed-signal IC, the IDT5V41066 must be isolated from system power supply noise to perform optimally.

Decoupling capacitors of 0.01 μ F must be connected between each VDD and the PCB ground plane.

PCB Layout Recommendations

For optimum device performance and lowest output phase noise, the following guidelines should be observed.

Each 0.01 μ F decoupling capacitor should be mounted on the component side of the board as close to the VDD pin as possible. No vias should be used between decoupling capacitor and VDD pin. The PCB trace to VDD pin should be kept as short as possible, as should the PCB trace to the ground via. Distance of the ferrite bead and bulk decoupling from the device is less critical.

2) An optimum layout is one with all components on the same side of the board, minimizing vias through other signal layers (the ferrite bead and bulk decoupling capacitor can be mounted on the back). Other signal traces should be routed away from the IDT5V41066.

This includes signal traces just underneath the device, or on layers adjacent to the ground plane layer used by the device.

External Components

A minimum number of external components are required for proper operation. Decoupling capacitors of 0.01 μ F should be connected between VDD and GND pairs (1,9 and 15,16) as close to the device as possible.

On chip capacitors- Crystal capacitors should be connected from pins X1 to ground and X2 to ground to optimize the initial accuracy. The value (in pf) of these crystal caps equal $(C_L - 12) * 2$ in this equation, C_L = crystal load capacitance in pf. For example, for a crystal with a 16 pF load cap, each external crystal cap would be 8 pF. $[(16 - 12) * 2] = 8$.

Current Reference Source R_r (I_{ref})

If board target trace impedance (Z) is 50 Ω , then $R_r = 475\Omega$ (1%), providing IREF of 2.32 mA, output current (I_{OH}) is equal to 6*IREF.

Load Resistors R_L

Since the clock outputs are open source outputs, 50 ohm external resistors to ground are to be connected at each clock output.

Output Termination

The PCI-Express differential clock outputs of the IDT5V41066 are open source drivers and require an external series resistor and a resistor to ground. These resistor values and their allowable locations are shown in detail in the **PCI-Express Layout Guidelines** section.

The IDT5V41066 can also be configured for LVDS compatible voltage levels. See the **LVDS Compatible Layout Guidelines** section.

Output Structures

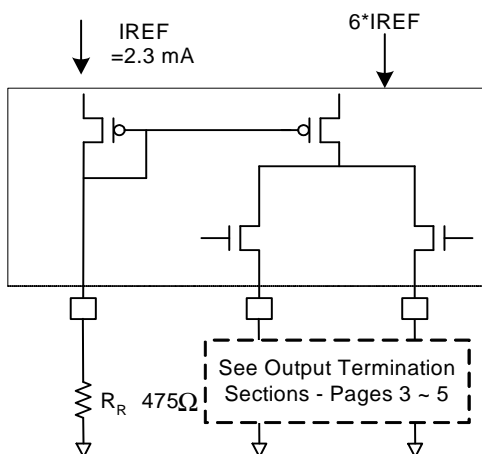

General PCB Layout Recommendations

For optimum device performance and lowest output phase noise, the following guidelines should be observed.

1. Each $0.01\mu\text{F}$ decoupling capacitor should be mounted on the component side of the board as close to the VDD pin as possible.
2. No vias should be used between decoupling capacitor and VDD pin.
3. The PCB trace to VDD pin should be kept as short as possible, as should the PCB trace to the ground via. Distance of the ferrite bead and bulk decoupling from the device is less critical.
4. An optimum layout is one with all components on the same side of the board, minimizing vias through other signal layers (any ferrite beads and bulk decoupling capacitors can be mounted on the back). Other signal traces should be routed away from the IDT5V41066. This includes signal traces just underneath the device, or on layers adjacent to the ground plane layer used by the device.

Layout Guidelines

SRC Reference Clock			
Common Recommendations for Differential Routing	Dimension or Value	Unit	Figure
L1 length, route as non-coupled 50ohm trace	0.5 max	inch	1
L2 length, route as non-coupled 50ohm trace	0.2 max	inch	1
L3 length, route as non-coupled 50ohm trace	0.2 max	inch	1
Rs	33	ohm	1
Rt	49.9	ohm	1

Down Device Differential Routing			
L4 length, route as coupled microstrip 100ohm differential trace	2 min to 16 max	inch	1
L4 length, route as coupled stripline 100ohm differential trace	1.8 min to 14.4 max	inch	1

Differential Routing to PCI Express Connector			
L4 length, route as coupled microstrip 100ohm differential trace	0.25 to 14 max	inch	2
L4 length, route as coupled stripline 100ohm differential trace	0.225 min to 12.6 max	inch	2

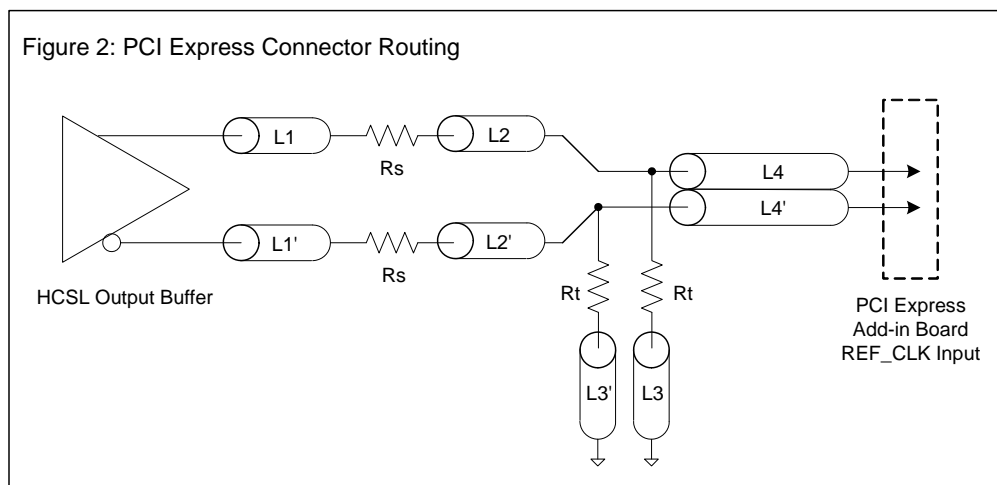
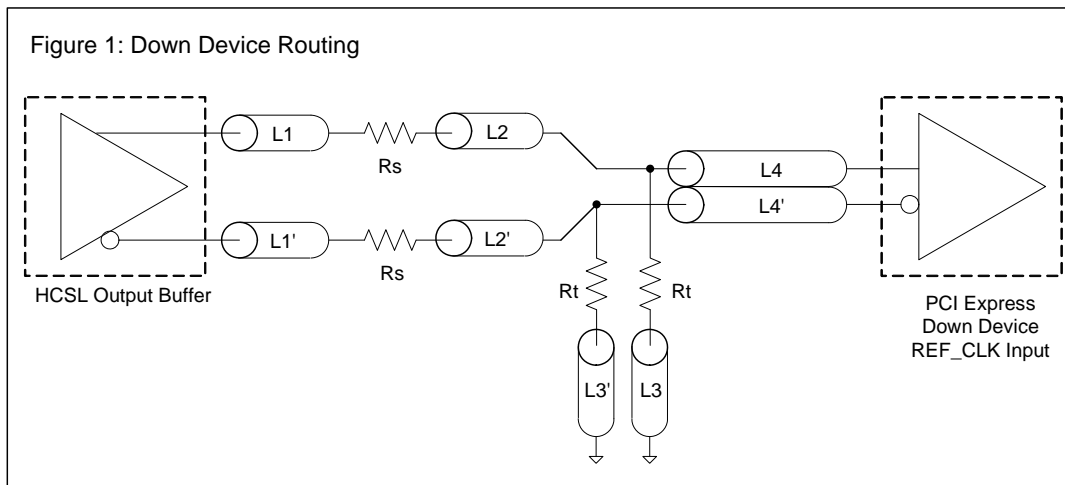

Alternative Termination for LVDS and other Common Differential Signals (figure 3)

Vdiff	Vp-p	Vcm	R1	R2	R3	R4	Note
0.45v	0.22v	1.08	33	150	100	100	
0.58	0.28	0.6	33	78.7	137	100	
0.80	0.40	0.6	33	78.7	none	100	ICS874003i-02 input compatible
0.60	0.3	1.2	33	174	140	100	Standard LVDS

R1a = R1b = R1

R2a = R2b = R2

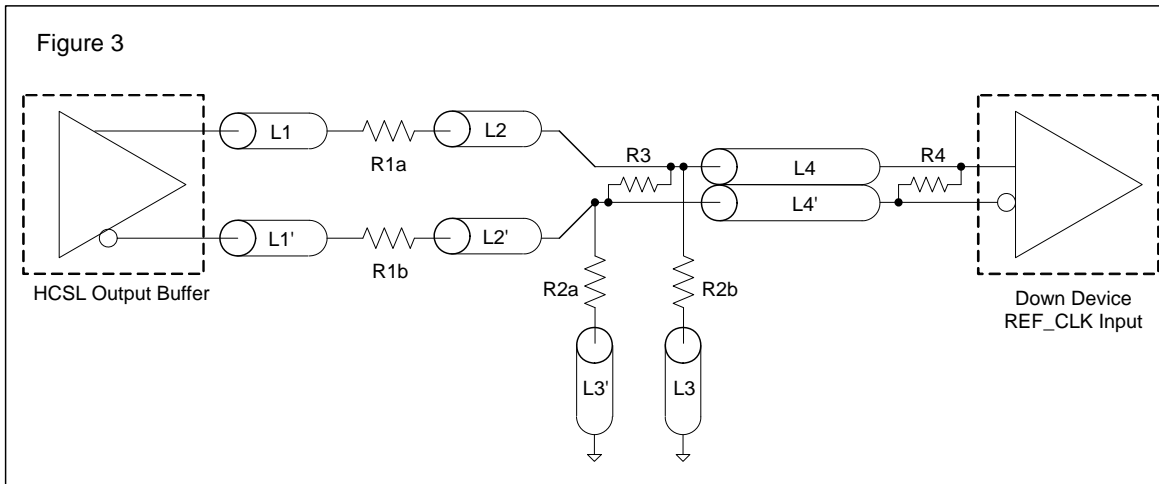

Cable Connected AC Coupled Application (figure 4)

Component	Value	Note
R5a, R5b	8.2K 5%	
R6a, R6b	1K 5%	
Cc	0.1 μ F	
Vcm	0.350 volts	

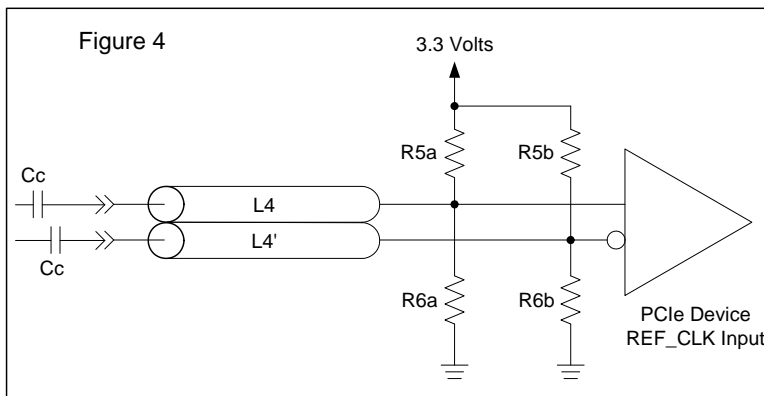

Typical PCI-Express (HCSL) Waveform

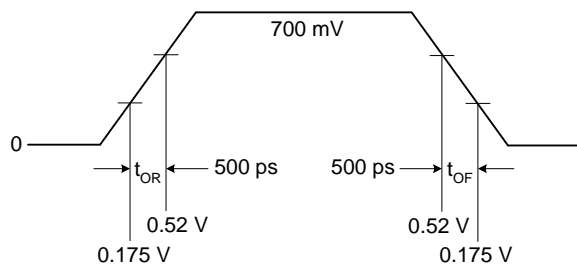

Typical LVDS Waveform

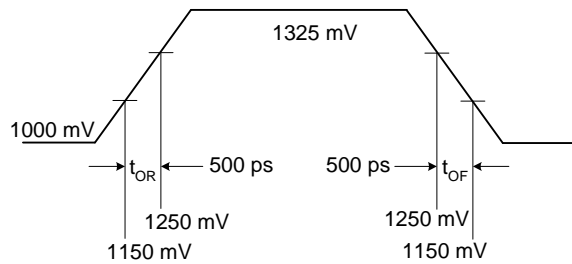

Absolute Maximum Ratings

Stresses above the ratings listed below can cause permanent damage to the IDT5V41066. These ratings are stress ratings only. Functional operation of the device at these or any other conditions above those indicated in the operational sections of the specifications is not implied. Exposure to absolute maximum rating conditions for extended periods can affect product reliability. Electrical parameters are guaranteed only over the recommended operating temperature range.

Item	Rating
Supply Voltage, VDD, VDDA	5.5 V
All Inputs and Outputs	-0.5 V to VDD+0.5 V
Ambient Operating Temperature (commercial)	0 to +70° C
Ambient Operating Temperature (industrial)	-40 to +85° C
Storage Temperature	-65 to +150° C
Junction Temperature	125° C
Soldering Temperature	260° C
ESD Protection (Input)	2000 V min. (HBM)

DC Electrical Characteristics

Unless stated otherwise, VDD = 3.3 V \pm 5%, Ambient Temperature -40 to +85° C

Parameter	Symbol	Conditions	Min.	Typ.	Max.	Units
Supply Voltage	V		3.135	3.3	3.465	
Input High Voltage ¹	V _{IH}		2.2		VDD +0.3	V
Input Low Voltage ¹	V _{IL}		VSS-0.3		0.8	V
Input Leakage Current ²	I _{IL}	0 < V _{in} < VDD	-5		5	μ A
Operating Supply Current @ 100 MHz	I _{DD}	R _S =33 Ω , R _P =50 Ω , C _L =2 pF		115	125	mA
	I _{DDOE}	OE =Low		42	48	mA
	I _{DDPD}	No load, \overline{PD} =Low		350	500	μ A
Input Capacitance	C _{IN}	Input pin capacitance			7	pF
Output Capacitance	C _{OUT}	Output pin capacitance			6	pF
X1, X2 Capacitance	C _{INX}				5	pF
Pin Inductance	L _{PIN}				5	nH
Output Impedance	Z _o	CLK outputs	3.0			k Ω
Pull-up Resistance	R _{PUP}	OE, SEL, \overline{PD} pins		110		k Ω

1. Single edge is monotonic when transitioning through region.
2. Inputs with pull-ups/-downs are not included.

AC Electrical Characteristics - CLKOUT (A:D)

Unless stated otherwise, $V_{DD}=3.3\text{ V} \pm 5\%$, Ambient Temperature -40 to +85° C

Parameter	Symbol	Conditions	Min.	Typ.	Max.	Units
Input Frequency				25		MHz
Output Frequency		HCSL termination	25		200	MHz
		LVDS termination	25		100	MHz
Output High Voltage ^{1,2}	V_{OH}	HCSL			850	mV
Output Low Voltage ^{1,2}	V_{OL}	HCSL	-150			mV
Crossing Point Voltage ^{1,2}		Absolute	250		550	mV
Crossing Point Voltage ^{1,2,4}		Variation over all edges			140	mV
Jitter, Cycle-to-Cycle ^{1,3}					100	ps
Frequency Synthesis Error		All outputs		0		ppm
Modulation Frequency		Spread spectrum	30	32.9	33	kHz
Rise Time ^{1,2}	t_{OR}	From 0.175 V to 0.525 V	175		700	ps
Fall Time ^{1,2}	t_{OF}	From 0.525 V to 0.175 V	175		700	ps
Rise/Fall Time Variation ^{1,2}					125	ps
Output to Output Skew					50	ps
Duty Cycle ^{1,3}			45		55	%
Output Enable Time ⁵		All outputs		50	100	ns
Output Disable Time ⁵		All outputs		50	100	ns
Stabilization Time	t_{STABLE}	From power-up $V_{DD}=3.3\text{ V}$			1.8	ms
Spread Spectrum Transition Time	t_{SPREAD}	Stabilization time after spread spectrum changes	7		30	ms

¹ Test setup is $R_S=33\Omega$, $R_P=50\Omega$ with $C_L=2\text{ pF}$, $R_r = 475\Omega$ (1%).

² Measurement taken from a single-ended waveform.

³ Measurement taken from a differential waveform.

⁴ Measured at the crossing point where instantaneous voltages of both CLKOUT and $\overline{\text{CLKOUT}}$ are equal.

⁵ CLKOUT pins are tri-stated when OE is asserted low. CLKOUT is driven differential when OE is high unless its $\overline{\text{PD}}$ is low.

Electrical Characteristics - Differential Phase Jitter

Parameter	Symbol	Conditions	Min	Typ	Max	Units	Notes
Jitter, Phase	$t_{j\text{phasePLL}}$	PCIe Gen1		30	86	ps (p-p)	1,2,3
	$t_{j\text{phaseLO}}$	PCIe Gen2, 10 kHz < f < 1.5 MHz		0.76	3	ps (RMS)	1,2,3
	$t_{j\text{phaseHIGH}}$	PCIe Gen2, 1.5 MHz < f < Nyquist (50 MHz)		2.0	3.1	ps (RMS)	1,2,3

Note 1. Guaranteed by design and characterization, not 100% tested in production.

Note 2. See <http://www.pcisig.com> for complete specs.

Note 3: Applies to 100MHz, spread off and 0.5% down spread only.

Thermal Characteristics

Parameter	Symbol	Conditions	Min.	Typ.	Max.	Units
Thermal Resistance Junction to Ambient	θ_{JA}	Still air		93		°C/W
	θ_{JA}	1 m/s air flow		78		°C/W
	θ_{JA}	3 m/s air flow		65		°C/W
Thermal Resistance Junction to Case	θ_{JC}			20		°C/W

Marking Diagram (5V41066PGG)

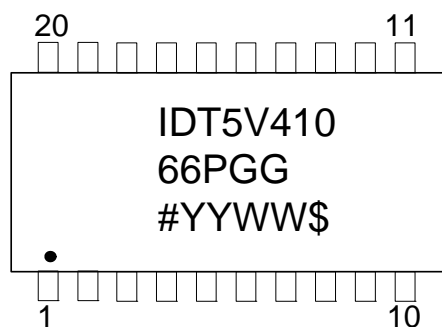

Marking Diagram (5V41066PGGI)

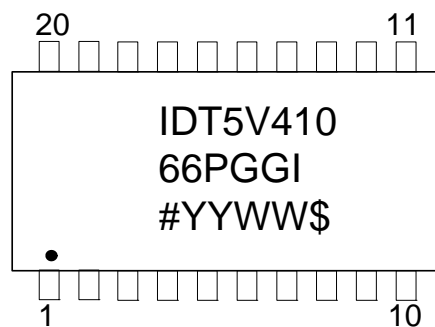

Notes:

1. Line 1 and 2: IDT part number.
2. Line 3: # – Die revision; YYWW – Date code; \$ – Assembly location.
3. “G” after the two-letter package code designates RoHS compliant package.
4. “I” at the end of part number indicates industrial temperature range.
5. Bottom marking: country of origin if not USA.

Package Outline and Package Dimensions (20-pin TSSOP, 173 mil Body)

Package dimensions are kept current with JEDEC Publication No. 95, MO-153

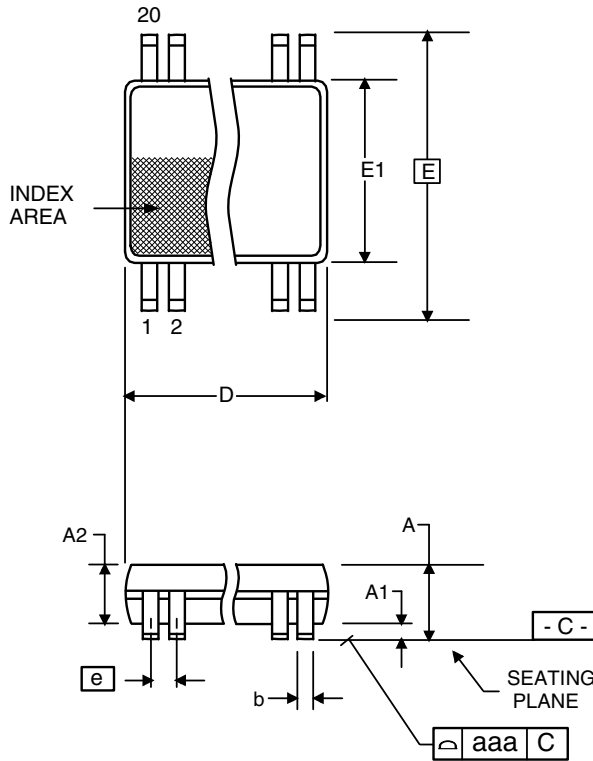

Symbol	Millimeters		Inches*	
	Min	Max	Min	Max
A		1.20		0.047
A1	0.05	0.15	0.002	0.006
A2	0.80	1.05	0.032	0.041
b	0.19	0.30	0.007	0.012
c	0.09	0.20	0.0035	0.008
D	6.40	6.60	0.252	0.260
E	6.40 BASIC		0.252 BASIC	
E1	4.30	4.50	0.169	0.177
e	0.65 Basic		0.0256 Basic	
L	0.45	0.75	0.018	0.030
a	0°	8°	0°	8°
aaa	--	0.10	--	0.004

Ordering Information

Part / Order Number	Marking	Shipping Packaging	Package	Temperature
5V41066PGG	see page 10	Tubes	20-pin TSSOP	0 to +70° C
5V41066PGG8		Tape and Reel	20-pin TSSOP	0 to +70° C
5V41066PGGI		Tubes	20-pin TSSOP	-40 to +85° C
5V41066PGGI8		Tape and Reel	20-pin TSSOP	-40 to +85° C

“G” after the two-letter package code are the Pb-Free configuration and are RoHS compliant.

While the information presented herein has been checked for both accuracy and reliability, Integrated Device Technology (IDT) assumes no responsibility for either its use or for the infringement of any patents or other rights of third parties, which would result from its use. No other circuits, patents, or licenses are implied. This product is intended for use in normal commercial applications. Any other applications such as those requiring extended temperature range, high reliability, or other extraordinary environmental requirements are not recommended without additional processing by IDT. IDT reserves the right to change any circuitry or specifications without notice. IDT does not authorize or warrant any IDT product for use in life support devices or critical medical instruments.

Revision History

Rev.	Originator	Date	Description of Change
A	RDW	01/20/10	New datasheet; Preliminary initial release.
B	RDW	04/27/10	Updated electrical tables per char; released to final.
C	RDW	07/19/10	1. Updated title and general description 2. Updated cycle-to-cycle jitter spec from 125 to 100 ps.
D	RDW	11/21/11	1. Changed title to "4 Output PCIe GEN1/2 Synthesizer" 2. Added note to Features section: "For PCIe Gen3 applications, see 5V41236" 3. Updated Differential Phase Jitter table.

IDT5V41066

4 OUTPUT PCIE GEN1/2 SYNTHESIZER

IMPORTANT NOTICE AND DISCLAIMER

RENESAS ELECTRONICS CORPORATION AND ITS SUBSIDIARIES (“RENESAS”) PROVIDES TECHNICAL SPECIFICATIONS AND RELIABILITY DATA (INCLUDING DATASHEETS), DESIGN RESOURCES (INCLUDING REFERENCE DESIGNS), APPLICATION OR OTHER DESIGN ADVICE, WEB TOOLS, SAFETY INFORMATION, AND OTHER RESOURCES “AS IS” AND WITH ALL FAULTS, AND DISCLAIMS ALL WARRANTIES, EXPRESS OR IMPLIED, INCLUDING, WITHOUT LIMITATION, ANY IMPLIED WARRANTIES OF MERCHANTABILITY, FITNESS FOR A PARTICULAR PURPOSE, OR NON-INFRINGEMENT OF THIRD-PARTY INTELLECTUAL PROPERTY RIGHTS.

These resources are intended for developers who are designing with Renesas products. You are solely responsible for (1) selecting the appropriate products for your application, (2) designing, validating, and testing your application, and (3) ensuring your application meets applicable standards, and any other safety, security, or other requirements. These resources are subject to change without notice. Renesas grants you permission to use these resources only to develop an application that uses Renesas products. Other reproduction or use of these resources is strictly prohibited. No license is granted to any other Renesas intellectual property or to any third-party intellectual property. Renesas disclaims responsibility for, and you will fully indemnify Renesas and its representatives against, any claims, damages, costs, losses, or liabilities arising from your use of these resources. Renesas' products are provided only subject to Renesas' Terms and Conditions of Sale or other applicable terms agreed to in writing. No use of any Renesas resources expands or otherwise alters any applicable warranties or warranty disclaimers for these products.

(Disclaimer Rev.1.01 Jan 2024)

Corporate Headquarters

TOYOSU FORESIA, 3-2-24 Toyosu,
Koto-ku, Tokyo 135-0061, Japan
www.renesas.com

Trademarks

Renesas and the Renesas logo are trademarks of Renesas Electronics Corporation. All trademarks and registered trademarks are the property of their respective owners.

Contact Information

For further information on a product, technology, the most up-to-date version of a document, or your nearest sales office, please visit www.renesas.com/contact-us/.

Looking for pricing, stock, or lifecycle information?

Click below to explore more details on WIN SOURCE:

-  [View 5V41066PGGI8 on WIN SOURCE](#)
-  [Renesas Electronics America](#) Information

Optimize Your Supply Chain with WIN SOURCE Solutions

-  Global Sourcing Solution
-  Obsolete Management
-  Cost Control Management
-  Shortage Management
-  Alternative Solution
-  Excess Inventory Management