



**THE DATASHEET OF
ICS950218AFLFT**



Programmable Timing Control Hub™ for P4™

Recommended Application:

Brookdale and Brookdale-G chipset with P4 processor.

Output Features:

- 3 - Pairs of differential CPU clocks (differential current mode)
- 3 - 3V66 @ 3.3V
- 10 - PCI @ 3.3V
- 1 - 48MHz @ 3.3V fixed
- 2 - REF @ 3.3V, 14.318MHz
- 1 - 48_66MHz selectable @ 3.3V fixed
- 1 - 24_48MHz selectable @ 3.3V

Features/Benefits:

- Programmable output frequency.
- Programmable output divider ratios.
- Programmable output rise/fall time.
- Programmable output skew.
- Programmable spread percentage for EMI control.
- Watchdog timer technology to reset system if system malfunctions.
- Programmable watch dog safe frequency.
- Support I²C Index read/write and block read/write operations.
- Uses external 14.318MHz crystal.

Key Specifications:

- CPU Output Jitter <150ps
- 3V66 Output Jitter <250ps
- CPU Output Skew <100ps

Frequency Table

Bit2	Bit7	Bit6	Bit5	Bit4	CPULCK MHz	3V66 MHz	PCICLK MHz
FS4	FS3	FS2	FS1	FS0			
0	0	0	0	0	102.00	68.00	34.00
0	0	0	0	1	105.00	70.00	35.00
0	0	0	1	0	108.00	72.00	36.00
0	0	0	1	1	111.00	74.00	37.00
0	0	1	0	0	114.00	76.00	38.00
0	0	1	0	1	117.00	78.00	39.00
0	0	1	1	0	120.00	80.00	40.00
0	0	1	1	1	123.00	82.00	41.00
0	1	0	0	0	126.00	72.00	36.00
0	1	0	0	1	130.00	74.30	37.10
0	1	0	1	0	136.00	68.00	34.00
0	1	0	1	1	140.00	70.00	35.00
0	1	1	0	0	144.00	72.00	36.00
0	1	1	0	1	148.00	74.00	37.00
0	1	1	1	0	152.00	76.00	38.00
0	1	1	1	1	156.00	78.00	39.00
1	0	0	0	0	160.00	80.00	40.00
1	0	0	0	1	164.00	82.00	41.00
1	0	0	1	0	166.60	66.60	33.30
1	0	0	1	1	170.00	68.00	34.00
1	0	1	0	0	175.00	70.00	35.00
1	0	1	0	1	180.00	72.00	36.00
1	0	1	1	0	185.00	74.00	37.00
1	0	1	1	1	190.00	76.00	38.00
1	1	0	0	0	66.80	66.80	33.40
1	1	0	0	1	100.20	66.80	33.40
1	1	0	1	0	133.60	66.80	33.40
1	1	0	1	1	200.40	66.80	33.40
1	1	1	0	0	66.60	66.60	33.30
1	1	1	0	1	100.00	66.60	33.30
1	1	1	1	0	200.00	66.60	33.30
1	1	1	1	1	133.33	66.60	33.30

Pin Configuration

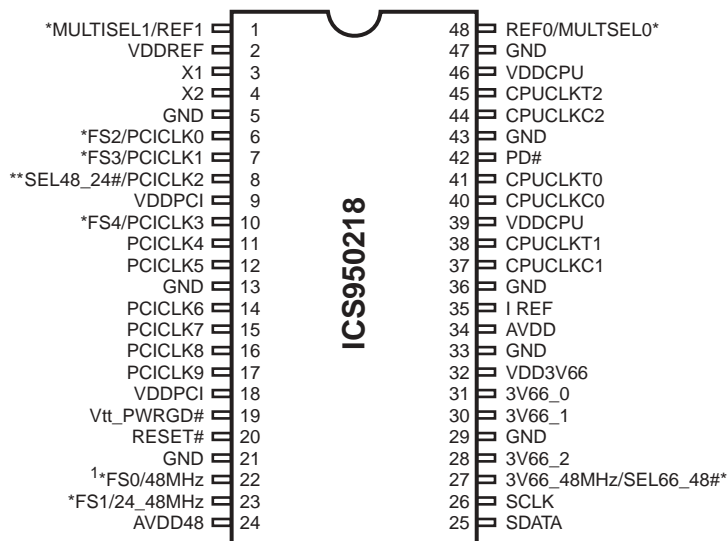

48-Pin 300-mil SSOP

1 This output has 2X drive

* Internal Pull-up resistor of 120K to VDD

** Internal Pull-down resistor of 120K to GND

General Description

The **ICS950218** is a single chip clock solution for desktop designs using the Intel Brookdale chipset with PC133 or DDR memory. It provides all necessary clock signals for such a system.

The **ICS950218** is part of a whole new line of ICS clock generators and buffers called TCH™ (Timing Control Hub). ICS is the first to introduce a whole product line which offers full programmability and flexibility on a single clock device. This part incorporates ICS's newest clock technology which offers more robust features and functionality. Employing the use of a serially programmable I²C interface, this device can adjust the output clocks by configuring the frequency setting, the output divider ratios, selecting the ideal spread percentage, the output skew, the output strength, and enabling/disabling each individual output clock. TCH also incorporates ICS's Watchdog Timer technology and a reset feature to provide a safe setting under unstable system conditions. M/N control can configure output frequency with resolution up to 0.1MHz increment. With all these programmable features ICS's, TCH makes mother board testing, tuning and improvement very simple.

Block Diagram

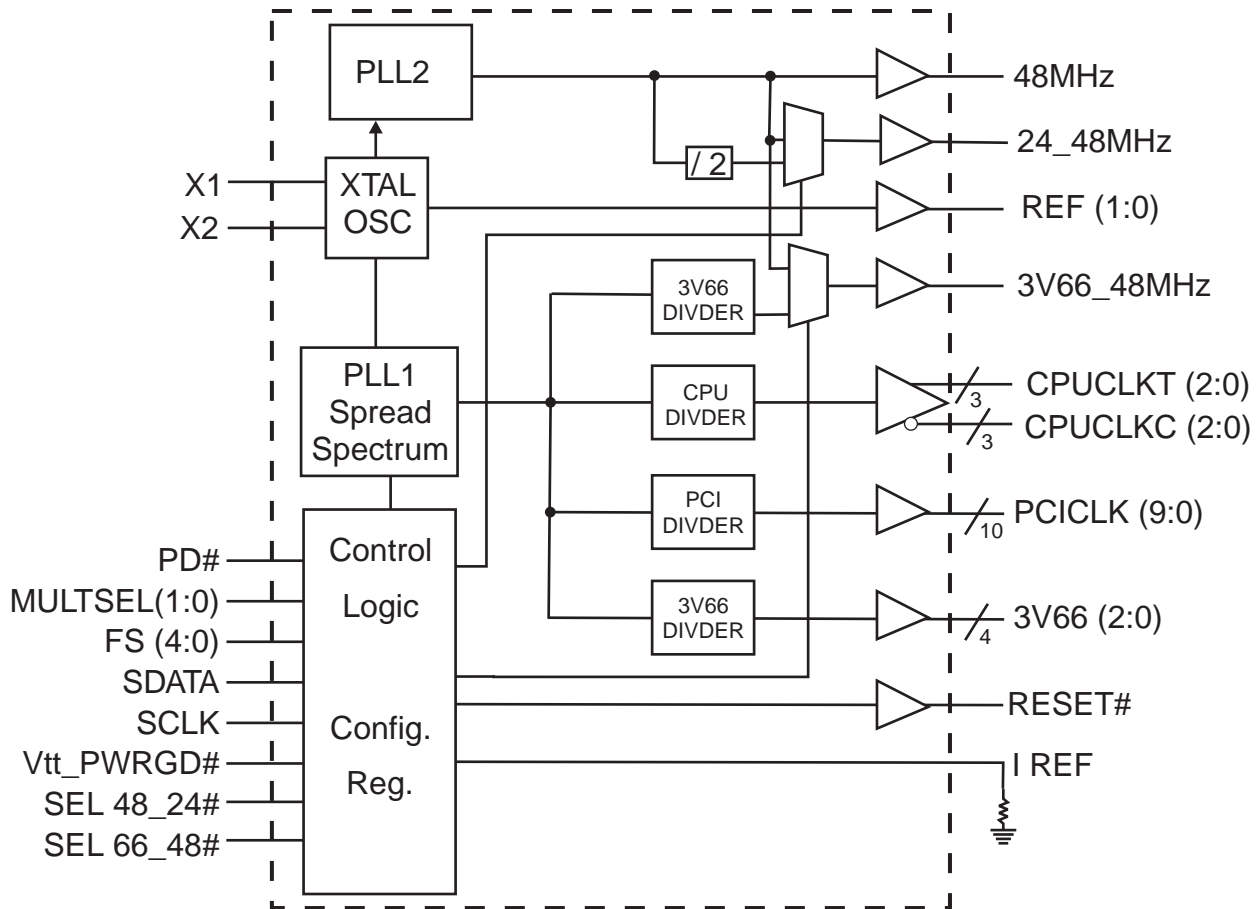

Pin Description

PIN NUMBER	PIN NAME	TYPE	DESCRIPTION
1	MULTSEL1	IN	3.3V LVTTTL input for selecting the current multiplier for CPU outputs.
	REF1	OUT	3.3V, 14.318MHz reference clock output.
2, 9, 18, 24, 32, 39, 46	VDD	PWR	3.3V power supply
3	X1	IN	Crystal input, has internal load cap (33pF) and feedback resistor from X2
4	X2	OUT	Crystal output, nominally 14.318MHz. Has internal load cap (33pF)
5, 13, 21, 29, 36, 43, 47	GND	PWR	Ground pins for 3.3V supply
6	FS2	IN	Logic input frequency select bit. Input latched at power on.
	PCICLK0	OUT	3.3V PCI clock output
7	FS3	IN	Logic input frequency select bit. Input latched at power on.
	PCICLK1	OUT	3.3V PCI clock output
8	SEL_48_24#	IN	This selects the frequency for the 24.48 MHz output. High = 48MHz, Low=24MHz
	PCICLK2	OUT	3.3V PCI clock output
10	FS4	IN	Logic input frequency select bit. Input latched at power on.
	PCICLK3	OUT	3.3V PCI clock output
17, 16, 15, 14, 12, 11	PCICLK (9:4)	OUT	3.3V PCI clock outputs
19	Vtt_PWRGD#	IN	This 5V tolerant LVTTTL input is a level sensitive strobe used to determine when FS (4:0) and MULTISEL inputs are valid and are ready to be sampled (active low)
20	RESET#	OUT	Real time system reset signal for frequency value or watchdog timer timeout. This signal is active low.
28, 30, 31	3V66 (2:0)	OUT	3.3V Fixed 66MHz clock outputs for HUB
22	FS0	IN	Logic input frequency select bit. Input latched at power on.
	48MHz	OUT	3.3V Fixed 48MHz clock output.
23	FS1	IN	Logic input frequency select bit. Input latched at power on.
	24_48MHz	OUT	Selectable 24 or 48MHz output.
25	SDATA	I/O	Data pin for I ² C circuitry 5V tolerant
26	SCLK	IN	Clock pin for I ² C circuitry 5V tolerant
27	SEL66_48#	IN	This selects the frequency for the 3V6_48 MHz output High = 66MHz, Low=48MHz
	3V66_48MHz	OUT	Selectable 66 or 48MHz output
33	GND	PWR	Ground for CORE PLL
34	AVDD	PWR	Power for CORE PLL 3.3V nominal
35	I REF	OUT	This pin establishes the reference current for the CPUCLK pairs. This pin requires a fixed precision resistor tied to ground in order to establish the appropriate current.
42	PD#	IN	Asynchronous active low input pin used to power down the device into a low power state. The internal clocks are disabled and the VCO and the crystal are stopped. The latency of the power down will not be greater than 3ms.
44, 40, 37	CPUCLKC (2:0)	OUT	"Complementary" clocks of differential pair CPU outputs. These are current outputs and external resistors are required for voltage bias.
45, 41, 38	CPUCLKT (2:0)	OUT	"True" clocks of differential pair CPU outputs. These are current outputs and external resistors are required for voltage bias.
48	MULTSELO	IN	3.3V LVTTTL input for selecting the current multiplier for CPU outputs.
	REF0	OUT	3.3V, 14.318MHz reference clock output.

Maximum Allowed Current

Condition	Max 3.3V supply consumption Max discrete cap loads, Vdd = 3.465V All static inputs = Vdd or GND
Powerdown Mode (PWRDWN# = 0)	40mA
Full Active	360mA

CPUCLK Swing Select Functions

MULTSEL0	MULTSEL1	Board Target Trace/Term Z	Reference R, $I_{ref} = \frac{V_{dd}}{3 \cdot R_r}$	Output Current	Voh @ Z, $I_{ref} = 2.32\text{mA}$
0	0	60 ohms	$R_r = 475 \cdot 1\%$ $I_{ref} = 2.32\text{mA}$	$I_{oh} = 5 \cdot I_{ref}$	0.71V @ 60
0	0	50 ohms	$R_r = 475 \cdot 1\%$ $I_{ref} = 2.32\text{mA}$	$I_{oh} = 5 \cdot I_{ref}$	0.59V @ 50
0	1	60 ohms	$R_r = 475 \cdot 1\%$ $I_{ref} = 2.32\text{mA}$	$I_{oh} = 6 \cdot I_{ref}$	0.85V /2 60
0	1	50 ohms	$R_r = 475 \cdot 1\%$ $I_{ref} = 2.32\text{mA}$	$I_{oh} = 6 \cdot I_{ref}$	0.71V @ 50
1	0	60 ohms	$R_r = 475 \cdot 1\%$ $I_{ref} = 2.32\text{mA}$	$I_{oh} = 4 \cdot I_{ref}$	0.56V @ 60
1	0	50 ohms	$R_r = 475 \cdot 1\%$ $I_{ref} = 2.32\text{mA}$	$I_{oh} = 4 \cdot I_{ref}$	0.47V @ 50
1	1	60 ohms	$R_r = 475 \cdot 1\%$ $I_{ref} = 2.32\text{mA}$	$I_{oh} = 7 \cdot I_{ref}$	0.99V @ 60
1	1	50 ohms	$R_r = 475 \cdot 1\%$ $I_{ref} = 2.32\text{mA}$	$I_{oh} = 7 \cdot I_{ref}$	0.82V @ 50
<hr/>					
0	0	30 (DC equiv)	$R_r = 221 \cdot 1\%$ $I_{ref} = 5\text{mA}$	$I_{oh} = 5 \cdot I_{ref}$	0.75V @ 30
0	0	25 (DC equiv)	$R_r = 221 \cdot 1\%$ $I_{ref} = 5\text{mA}$	$I_{oh} = 5 \cdot I_{ref}$	0.62V @ 20
0	1	30 (DC equiv)	$R_r = 221 \cdot 1\%$ $I_{ref} = 5\text{mA}$	$I_{oh} = 6 \cdot I_{ref}$	0.90V @ 30
0	1	25 (DC equiv)	$R_r = 221 \cdot 1\%$ $I_{ref} = 5\text{mA}$	$I_{oh} = 6 \cdot I_{ref}$	0.75V @ 20
1	0	30 (DC equiv)	$R_r = 221 \cdot 1\%$ $I_{ref} = 5\text{mA}$	$I_{oh} = 4 \cdot I_{ref}$	0.60 @ 20
1	0	25 (DC equiv)	$R_r = 221 \cdot 1\%$ $I_{ref} = 5\text{mA}$	$I_{oh} = 4 \cdot I_{ref}$	0.5V @ 20
1	1	30 (DC equiv)	$R_r = 221 \cdot 1\%$ $I_{ref} = 5\text{mA}$	$I_{oh} = 7 \cdot I_{ref}$	1.05V @ 30
1	1	25 (DC equiv)	$R_r = 221 \cdot 1\%$ $I_{ref} = 5\text{mA}$	$I_{oh} = 7 \cdot I_{ref}$	0.84V @ 20

General I²C serial interface information

How to Write:

- Controller (host) sends a start bit.
- Controller (host) sends the write address D2_(H)
- ICS clock will **acknowledge**
- Controller (host) sends the beginning byte location = N
- ICS clock will **acknowledge**
- Controller (host) sends the data byte count = X
- ICS clock will **acknowledge**
- Controller (host) starts sending **Byte N through Byte N + X - 1**
(see Note 2)
- ICS clock will **acknowledge** each byte **one at a time**
- Controller (host) sends a Stop bit

How to Read:

- Controller (host) will send start bit.
- Controller (host) sends the write address D2_(H)
- ICS clock will **acknowledge**
- Controller (host) sends the beginning byte location = N
- ICS clock will **acknowledge**
- Controller (host) will send a separate start bit.
- Controller (host) sends the read address D3_(H)
- ICS clock will **acknowledge**
- ICS clock will send the data byte count = X
- ICS clock sends **Byte N + X - 1**
- ICS clock sends **Byte 0 through byte X (if X_(H) was written to byte 8).**
- Controller (host) will need to acknowledge each byte
- Controller (host) will send a not acknowledge bit
- Controller (host) will send a stop bit

Index Block Write Operation		
Controller (Host)		ICS (Slave/Receiver)
T	starT bit	
Slave Address D2 _(H)		
WR	WRite	
		ACK
Beginning Byte = N		
		ACK
Data Byte Count = X		
		ACK
Beginning Byte N		X Byte
○		
○		
○		
Byte N + X - 1		
		ACK
P	stoP bit	

Index Block Read Operation		
Controller (Host)		ICS (Slave/Receiver)
T	starT bit	
Slave Address D2 _(H)		
WR	WRite	
		ACK
Beginning Byte = N		
		ACK
RT	Repeat starT	
Slave Address D3 _(H)		
RD	ReaD	
		ACK
		Data Byte Count = X
ACK		
ACK		X Byte
Beginning Byte N		
○		
○		
○		
		Byte N + X - 1
N	Not acknowledge	
P	stoP bit	

*See notes on the following page.

0466B—03/17/04

Byte 0: Functionality and frequency select register (Default=0)

Bit	Description									PWD	
Bit (2,7:4)	Bit2	Bit7	Bit6	Bit5	Bit4	CPUCLK MHz	3V66 MHz	PCICLK MHz	Spread %	Note 1	
	FS4	FS3	FS2	FS1	FS0						
	0	0	0	0	0	0	102.00	68.00	34.00		+/-0.25% Center spread
	0	0	0	0	1	1	105.00	70.00	35.00		+/-0.25% Center spread
	0	0	0	1	0	0	108.00	72.00	36.00		+/-0.25% Center spread
	0	0	0	1	1	1	111.00	74.00	37.00		+/-0.25% Center spread
	0	0	1	0	0	0	114.00	76.00	38.00		+/-0.25% Center spread
	0	0	1	0	1	1	117.00	78.00	39.00		+/-0.25% Center spread
	0	0	1	1	0	0	120.00	80.00	40.00		+/-0.25% Center spread
	0	0	1	1	1	1	123.00	82.00	41.00		+/-0.25% Center spread
	0	1	0	0	0	0	126.00	72.00	36.00		+/-0.25% Center spread
	0	1	0	0	1	1	130.00	74.30	37.10		+/-0.25% Center spread
	0	1	0	1	0	0	136.00	68.00	34.00		+/-0.25% Center spread
	0	1	0	1	1	1	140.00	70.00	35.00		+/-0.25% Center spread
	0	1	1	0	0	0	144.00	72.00	36.00		+/-0.25% Center spread
	0	1	1	0	1	1	148.00	74.00	37.00		+/-0.25% Center spread
	0	1	1	1	1	0	152.00	76.00	38.00		+/-0.25% Center spread
	0	1	1	1	1	1	156.00	78.00	39.00		+/-0.25% Center spread
	1	0	0	0	0	0	160.00	80.00	40.00		+/-0.25% Center spread
	1	0	0	0	1	1	164.00	82.00	41.00		+/-0.25% Center spread
	1	0	0	1	0	0	166.60	66.60	33.30		+/-0.25% Center spread
	1	0	0	1	1	1	170.00	68.00	34.00		+/-0.25% Center spread
	1	0	1	0	0	0	175.00	70.00	35.00		+/-0.25% Center spread
	1	0	1	0	1	1	180.00	72.00	36.00		+/-0.25% Center spread
	1	0	1	1	0	0	185.00	74.00	37.00		+/-0.25% Center spread
	1	0	1	1	1	1	190.00	76.00	38.00		+/-0.25% Center spread
	1	1	0	0	0	0	66.80	66.80	33.40		+/-0.25% Center spread
	1	1	0	0	1	1	100.20	66.80	33.40		+/-0.25% Center spread
	1	1	0	1	0	0	133.60	66.80	33.40		+/-0.25% Center spread
1	1	0	1	1	1	200.40	66.80	33.40	+/-0.25% Center spread		
1	1	1	0	0	0	66.60	66.60	33.30	0 to -0.5% Down spread		
1	1	1	0	1	1	100.00	66.60	33.30	0 to -0.5% Down spread		
1	1	1	1	0	0	200.00	66.60	33.30	0 to -0.5% Down spread		
1	1	1	1	1	1	133.33	66.60	33.30	0 to -0.5% Down spread		
Bit 3	0 - Frequency is selected by hardware select, latched inputs 1 - Frequency is selected by Bit 2,7:4									0	
Bit 1	0 - Normal 1 - Spread spectrum enable									0	
Bit 0	0 - Watch dog safe frequency will be selected by latch inputs 1 - Watch dog safe frequency will be programmed by Byte 10 bit (4:0)									0	

Notes:

1. Default at power-up will be for latched logic inputs to define frequency, as displayed by Bit 3.

Byte 1: Output Control Register
(1 = enable, 0 = disable)

Bit	Pin#	PWD	Description
Bit7	45,44	1	CPUT/C2
Bit6	38,37	1	CPUT/C1
Bit5	41,40	1	CPUT/C0
Bit4	-	X	FS4 Read back
Bit3	-	X	FS3 Read back
Bit2	-	X	FS2 Read back
Bit1	-	X	FS1 Read back
Bit0	-	X	FS0 Read back

Byte 2: Output Control Register
(1 = enable, 0 = disable)

Bit	Pin#	PWD	Description
Bit7	-	1	Reserved
Bit6	17	1	PCICLK_9
Bit5	16	1	PCICLK_8
Bit4	15	1	PCICLK_7
Bit3	14	1	PCICLK_6
Bit2	12	1	PCICLK_5
Bit1	11	1	PCICLK_4
Bit0	10	1	PCICLK_3

Byte 3: Output Control Register
(1 = enable, 0 = disable)

Bit	Pin#	PWD	Description
Bit7	23	1	24_48MHz
Bit6	22	1	48MHz
Bit5	-	1	Reset gear shift detect 1 = Enable, 0 = Disable
Bit4	-	0	0 = Sel 48_24# by hardware; 1 = I ² C
Bit3	-	0	Sel 48_24#, 0 = 24MHz, 1 = 48MHz
Bit2	8	1	PCICLK_2
Bit1	7	1	PCICLK_1
Bit0	6	1	PCICLK_0

Byte 4: Output Control Register
(1 = enable, 0 = disable)

Bit	Pin#	PWD	Description
Bit 7	-	X	MultiSEL0 (read back)
Bit 6	-	X	MultiSEL1 (Read back)
Bit 5	31	1	3V66_0
Bit 4	30	1	3V66_1
Bit 3	48	1	REF0
Bit 2	1	1	REF1
Bit 1	27	1	3V66_48MHz
Bit 0	28	1	3V66_2

Notes:

1. PWD = Power on Default
2. For disabled clocks, they stop low for single ended clocks. Differential CPU clocks stop with CPUCLKT at high, CPUCLKC off, and external resistor termination will bring CPUCLKC low.

Byte 5: Programming Edge Rate
(1 = enable, 0 = disable)

Bit	Pin#	PWD	Description
Bit 7	X	X	Sel 48_24# (Read back)
Bit 6	X	X	Sel 66_48# (Read back)
Bit 5	X	1	(Reserved)
Bit 4	X	1	(Reserved)
Bit 3	X	0	0 = Sel 66_48# by hardware; 1 = by I ² C
Bit 2	X	1	Sel 66_48#, 0 = 48MHz, 1 = 66MHz
Bit 1	X	1	Async. frequency control bit 1
Bit 0	X	0	Async. frequency control bit 0

Asynchronous Frequency Control Table

Byte 5 Bit 1	Byte 5 Bit 0	3V66 [3:0]	PCI [9:0]	Note
0	0	66.01 MHz	33.005 MHz	From Fix PLL (No spread)
0	1	75.44 MHz	37.72 MHz	From Fix PLL (No spread)
1	0	66.66 MHz	33.33 MHz	From main PLL (Default)
1	1	88.01 MHz	44.005 MHz	From Fix PLL (No spread)

Byte 6: Vendor ID Register
(1 = enable, 0 = disable)

Bit	Name	PWD	Description
Bit 7	Revision ID Bit3	X	Revision ID values will be based on individual device's revision
Bit 6	Revision ID Bit2	X	
Bit 5	Revision ID Bit1	X	
Bit 4	Revision ID Bit0	X	
Bit 3	Vendor ID Bit3	0	(Reserved)
Bit 2	Vendor ID Bit2	0	(Reserved)
Bit 1	Vendor ID Bit1	0	(Reserved)
Bit 0	Vendor ID Bit0	1	(Reserved)

Byte 7: Revision ID and Device ID Register

Bit	Name	PWD	Description
Bit 7	Device ID7	0	Device ID values will be based on individual device "28H" in this case.
Bit 6	Device ID6	0	
Bit 5	Device ID5	1	
Bit 4	Device ID4	0	
Bit 3	Device ID3	1	
Bit 2	Device ID2	0	
Bit 1	Device ID1	0	
Bit 0	Device ID0	0	

Byte 8: Byte Count Read Back Register

Bit	Name	PWD	Description
Bit 7	Byte7	0	Note: Writing to this register will configure byte count and how many bytes will be read back, default is $0F_H = 15$ bytes.
Bit 6	Byte6	0	
Bit 5	Byte5	0	
Bit 4	Byte4	0	
Bit 3	Byte3	1	
Bit 2	Byte2	1	
Bit 1	Byte1	1	
Bit 0	Byte0	1	

Byte 9: Watchdog Timer Count Register

Bit	Name	PWD	Description
Bit 7	WD7	0	The decimal representation of these 8 bits correspond to $X \cdot 290ms$ the watchdog timer will wait before it goes to alarm mode and reset the frequency to the safe setting. Default at power up is $8 \cdot 290ms = 2.3$ seconds.
Bit 6	WD6	0	
Bit 5	WD5	0	
Bit 4	WD4	0	
Bit 3	WD3	1	
Bit 2	WD2	0	
Bit 1	WD1	0	
Bit 0	WD0	0	

Byte 10: Programming Enable bit 8 Watchdog Control Register

Bit	Name	PWD	Description
Bit 7	Program Enable	0	Programming Enable bit 0 = no programming. Frequencies are selected by HW latches or Byte0 1 = enable all I ² C programming.
Bit 6	WD Enable	0	Watchdog Enable bit. This bit will over write WDEN latched value. 0 = disable, 1 = Enable.
Bit 5	WD Alarm	0	Watchdog Alarm Status 0 = normal 1= alarm status
Bit 4	SF4	0	Watchdog safe frequency bits. Writing to these bits will configure the safe frequency corresponding to Byte 0 Bit 2, 7:4 table
Bit 3	SF3	1	
Bit 2	SF2	1	
Bit 1	SF1	1	
Bit 0	SF0	1	

Byte 11: VCO Frequency M Divider (Reference divider) Control Register

Bit	Name	PWD	Description
Bit 7	Ndiv 8	X	N divider bit 8
Bit 6	Mdiv 6	X	The decimal representation of Mdiv (6:0) correspond to the reference divider value. Default at power up is equal to the latched inputs selection.
Bit 5	Mdiv 5	X	
Bit 4	Mdiv 4	X	
Bit 3	Mdiv 3	X	
Bit 2	Mdiv 2	X	
Bit 1	Mdiv 1	X	
Bit 0	Mdiv 0	X	

Byte 12: VCO Frequency N Divider (VCO divider) Control Register

Bit	Name	PWD	Description
Bit 7	Ndiv 7	X	The decimal representation of Ndiv (8:0) correspond to the VCO divider value. Default at power up is equal to the latched inputs selecton. Notice Ndiv 8 is located in Byte 11.
Bit 6	Ndiv 6	X	
Bit 5	Ndiv 5	X	
Bit 4	Ndiv 4	X	
Bit 3	Ndiv 3	X	
Bit 2	Ndiv 2	X	
Bit 1	Ndiv 1	X	
Bit 0	Ndiv 0	X	

Byte 13: Spread Spectrum Control Register

Bit	Name	PWD	Description
Bit 7	SS 7	X	The Spread Spectrum (12:0) bit will program the spread percentage. Spread percent needs to be calculated based on the VCO frequency, spreading profile, spreading amount and spread frequency. It is recommended to use ICS software for spread programming. Default power on is latched FS divider.
Bit 6	SS 6	X	
Bit 5	SS 5	X	
Bit 4	SS 4	X	
Bit 3	SS 3	X	
Bit 2	SS 2	X	
Bit 1	SS 1	X	
Bit 0	SS 0	X	

Byte 14: Spread Spectrum Control Register

Bit	Name	PWD	Description
Bit 7	Reserved	X	Reserved
Bit 6	Reserved	X	Reserved
Bit 5	Reserved	X	Reserved
Bit 4	SS 12	X	Spread Spectrum Bit 12
Bit 3	SS 11	X	Spread Spectrum Bit 11
Bit 2	SS 10	X	Spread Spectrum Bit 10
Bit 1	SS 9	X	Spread Spectrum Bit 9
Bit 0	SS 8	X	Spread Spectrum Bit 8

Byte 15: Output Divider Control Register

Bit	Name	PWD	Description
Bit 7	CPUDIV3	X	CPU2 clock divider ratio can be configured via these 4 bits individually. For divider selection table refer to Table 1. Default at power up is latched FS divider.
Bit 6	CPUDIV2	X	
Bit 5	CPUDIV1	X	
Bit 4	CPUDIV0	X	
Bit 3	CPU Div 3	X	CPU(1:0) clock divider ratio can be configured via these 4 bits individually. For divider selection table refer to Table 1. Default at power up is latched FS divider.
Bit 2	CPU Div 2	X	
Bit 1	CPU Div 1	X	
Bit 0	CPU Div 0	X	

Byte 16: Output Divider Control Register

Bit	Name	PWD	Description
Bit 7	3V66 Div 3	X	3V66(3:2) clock divider ratio can be configured via these 4 bits individually. For divider selection table refer to Table 1. Default at power up is latched FS divider.
Bit 6	3V66 Div 2	X	
Bit 5	3V66 Div 1	X	
Bit 4	3V66 Div 0	X	
Bit 3	3V66 Div 3	X	3V66(1:0) clock divider ratio can be configured via these 4 bits individually. For divider selection table refer to Table 1. Default at power up is latched FS divider.
Bit 2	3V66 Div 2	X	
Bit 1	3V66 Div 1	X	
Bit 0	3V66 Div 0	X	

Byte 17: Output Divider Control Register

Bit	Name	PWD	Description
Bit 7	3V66(3:2)_INV	X	3V66(3:2) Phase Inversion bit
Bit 6	3V66(1:0)_INV	X	3V66(1:0) Phase Inversion bit
Bit 5	CPU_INV	X	CPUCLK_2 Phase Inversion bit
Bit 4	CPU_INV	X	CPUCLK Phase Inversion bit
Bit 3	PCI Div 3	X	PCI clock divider ratio can be configured via these 4 bits individually. For divider selection table refer to Table 2. Default at power up is latched FS divider.
Bit 2	PCI Div 2	X	
Bit 1	PCI Div 1	X	
Bit 0	PCI Div 0	X	

Table 1

Div (3:2)	00	01	10	11
Div (1:0)				
00	/2	/4	/8	/16
01	/3	/6	/12	/24
10	/5	/10	/20	/40
11	/7	/14	/28	/56

Table 2

Div (3:2)	00	01	10	11
Div (1:0)				
00	/4	/8	/16	/32
01	/3	/6	/12	/24
10	/5	/10	/20	/40
11	/9	/18	/36	/72

Byte 18: Group Skew Control Register

Bit	Name	PWD	Description
Bit 7	CPU_Skew 1	0	These 2 bits delay the CPUCLKC/T2 with respect to CPUCLKC/T (1:0) 00 = 0ps 01 = 250ps 10 = 500ps 11 =750ps
Bit 6	CPU_Skew 0	1	
Bit 5	Reserved	0	Reserved
Bit 4	Reserved	0	Reserved
Bit 3	CPU_Skew 1	0	These 2 bits delay the CPUCLKC/T (1:0) clock with respect to CPUCLKC/T2 00 = 0ps 01 = 250ps 10 = 500ps 11 = 750ps
Bit 2	CPU_Skew 0	1	
Bit 1	Reserved	0	Reserved
Bit 0	Reserved	0	Reserved

Byte 19: Group Skew Control Register

Bit	Name	PWD	Programming Sequence					
Bit 7	These 4bits control CPU-3V66(3:2)	0	0	0	0	0	0ps	Reserved
Bit 6		1	0	1	0	0	150ps	Reserved
Bit 5		0	1	0	0	0	300ps	Reserved
Bit 4		0	1	1	0	0	450ps	Reserved
Bit 3	These 4 bits control CPU-3V66(1:0)	0	1	1	0	1	600ps	Reserved
Bit 2		1	1	1	1	0	750ps	Reserved
Bit 1		0	1	1	1	1	900ps	Reserved
Bit 0		0	Reserved				Reserved	

Byte 20: Group Skew Control Register

Bit	Name	PWD	Programming Sequence					
Bit 7	These 4bits control CPU-PCI(9:0)	1	0	0	0	0	0ps	Reserved
Bit 6		0	0	1	0	0	150ps	Reserved
Bit 5		0	1	0	0	0	300ps	Reserved
Bit 4		0	1	1	0	0	450ps	Reserved
Bit 3	Resreved	1	1	1	0	1	600ps	Reserved
Bit 2		0	1	1	1	0	750ps	Reserved
Bit 1		0	1	1	1	1	900ps	Reserved
Bit 0		0	Reserved				Reserved	

Byte 21: Slew Rate Control Register

Bit	Name	PWD	Description
Bit 7	PCICLK_2_Slew 1	1	PCICLK2 clock slew rate control bits. 01 = strong; 11 = normal; 10 = weak
Bit 6	PCICLK_2_Slew 0	0	
Bit 5	PCICLK (1:0)_Slew 0	1	PCICLK(1:0) clock slew rate control bits. 01 = strong; 11 = normal; 10 = weak
Bit 4	PCICLK (1:0)_Slew 0	0	
Bit 3	3V66 (3:2)_Slew 1	1	3V66 (2:1) clock slew rate control bits. 01 = strong; 11 = normal; 10 = weak
Bit 2	3V66 (3:2)_Slew 0	0	
Bit 1	3V66 (1:0)_Slew 1	1	3V66 (1:0) clock slew rate control bits. 01 = strong; 11 = normal; 10 = weak
Bit 0	3V66 (1:0)_Slew 0	0	

Byte 22: Slew Rate Control Register

Bit	Name	PWD	Description
Bit 7	REF Slew 1	1	REF clock slew rate control bits. 01 = strong; 11 = normal; 10 = weak
Bit 6	REF Slew 0	0	
Bit 5	PCI (9:7) Slew 1	1	PCI (9:7) clock slew rate control bits. 01 = strong; 11 = normal; 10 = weak
Bit 4	PCI (9:7) Slew 0	0	
Bit 3	PCI (6:5) Slew 1	1	PCI (6:5) clock slew rate control bits. 01 = strong; 11 = normal; 10 = weak
Bit 2	PCI (6:5) Slew 0	0	
Bit 1	PCI (4:3) Slew 1	1	PCI (4:3) clock slew rate control bits. 01 = strong; 11 = normal; 10 = weak
Bit 0	PCI (4:3) Slew 0	0	

Byte 23: Slew Rate Control Register

Bit	Name	PWD	Description
Bit 7	Reserved	X	Reserved
Bit 6	Reserved	X	
Bit 5	Reserved	1	
Bit 4	Reserved	0	
Bit 3	48MHz Slew 1	1	48MHz clock slew rate control bits. 01 = strong; 11 = normal; 10 = weak
Bit 2	48MHz Slew 0	0	
Bit 1	24_48MHz Slew 1	1	24_48MHz clock slew rate control bits. 01 = strong; 11 = normal; 10 = weak
Bit 0	24_48MHz Slew 0	0	

Absolute Maximum Ratings

Supply Voltage	5.5 V
Logic Inputs	GND -0.5 V to V _{DD} +0.5 V
Ambient Operating Temperature	0°C to +70°C
Case Temperature	115°C
Storage Temperature	-65°C to +150°C

Stresses above those listed under *Absolute Maximum Ratings* may cause permanent damage to the device. These ratings are stress specifications only and functional operation of the device at these or any other conditions above those listed in the operational sections of the specifications is not implied. Exposure to absolute maximum rating conditions for extended periods may affect product reliability.

Electrical Characteristics - Input/Supply/Common Output Parameters

T_A = 0 - 70°C; Supply Voltage V_{DD} = 3.3 V +/-5%

PARAMETER	SYMBOL	CONDITIONS	MIN	TYP	MAX	UNITS
Input High Voltage	V _{IH}		2		V _{DD} + 0.3	V
Input Low Voltage	V _{IL}		V _{SS} - 0.3		0.8	V
Input High Current	I _{IH}	V _{IN} = V _{DD}	-5		5	μA
Input Low Current	I _{IL1}	V _{IN} = 0 V; Inputs with no pull-up resistors	-5			
	I _{IL2}	V _{IN} = 0 V; Inputs with pull-up resistors	-200			
Operating Supply Current	I _{DD3.3OP1}	C _L = 0pF; Select @ 66 MHz		90	100	mA
	I _{DD3.3OP2}	C _L = Full load; Select @ 100 MHz		230	360	
	I _{DD3.3OP3}	C _L = Full load; Select @ 133 MHz		233	360	
Powerdown Current	I _{DD3.3PD}	I _{REF} = 5 mA		38.1	45	
Input Frequency	F _i	V _{DD} = 3.3 V		14.32		MHz
Pin Inductance	L _{pin}				7	nH
Input Capacitance ¹	C _{IN}	Logic Inputs			5	pF
	C _{OUT}	Output pin capacitance			6	pF
	C _{INX}	X1 & X2 pins	27	36	45	pF
Transition time ¹	T _{trans}	To 1st crossing of target frequency			3	ms
Settling time ¹	T _s	From 1st crossing to 1% target frequency			3	ms
Clk Stabilization ¹	T _{STAB}	From V _{DD} = 3.3 V to 1% target frequency		1	3	ms
Delay ¹	t _{PZH} , t _{PZL}	Output enable delay (all outputs)	1		10	ns
	t _{PHZ} , t _{PLZ}	Output disable delay (all outputs)	1		10	ns

¹Guaranteed by design, not 100% tested in production.

Electrical Characteristics - CPU 0.7V Current Mode Differential Pair

$T_A = 0 - 70^\circ\text{C}$; $V_{DD} = 3.3\text{ V} \pm 5\%$; $C_L = 2\text{pF}$

PARAMETER	SYMBOL	CONDITIONS	MIN	TYP	MAX	UNITS	NOTES
Current Source Output Impedance	Z_o^1	$V_o = V_x$	3000			Ω	1
Voltage High	VHigh	Statistical measurement on single ended signal using oscilloscope math function.	660	770	850	mV	1
Voltage Low	VLow		-150	5	150		1
Max Voltage	Vovs	Measurement on single ended signal using absolute value.		756	1150	mV	1
Min Voltage	Vuds		-300	-7			1
Crossing Voltage (abs)	Vcross(abs)		250	350	550	mV	1
Crossing Voltage (var)	d-Vcross	Variation of crossing over all edges		12	140	mV	1
Long Accuracy	ppm	see Tperiod min-max values	-300		300	ppm	1,2
Average period	Tperiod	200MHz nominal	4.9985		5.0015	ns	2
		200MHz spread	4.9985		5.0266	ns	2
		166.66MHz nominal	5.9982		6.0018	ns	2
		166.66MHz spread	5.9982		6.0320	ns	2
		133.33MHz nominal	7.4978		7.5023	ns	2
		133.33MHz spread	7.4978		5.4000	ns	2
		100.00MHz nominal	9.9970		10.0030	ns	2
		100.00MHz spread	9.9970		10.0533	ns	2
Absolute min period	T_{absmin}	200MHz nominal	4.8735			ns	1,2
		166.66MHz nominal/spread	5.8732			ns	1,2
		133.33MHz nominal/spread	7.3728			ns	1,2
		100.00MHz nominal/spread	9.8720			ns	1,2
Rise Time	t_r	$V_{OL} = 0.175\text{V}$, $V_{OH} = 0.525\text{V}$	175	332	700	ps	1
Fall Time	t_f	$V_{OH} = 0.525\text{V}$ $V_{OL} = 0.175\text{V}$	175	344	700	ps	1
Rise Time Variation	d- t_r			30	125	ps	1
Fall Time Variation	d- t_f			30	125	ps	1
Duty Cycle	d_{t3}	Measurement from differential waveform	45	49	55	%	1
Skew	t_{sk3}	$V_T = 50\%$		8	100	ps	1
Jitter, Cycle to cycle	$t_{jyc-cyc}$	Measurement from differential waveform		60	150	ps	1

¹Guaranteed by design, not 100% tested in production.

²All Long Term Accuracy and Clock Period specifications are guaranteed with the assumption that Ref output is at 14.31818MHz

Electrical Characteristics - 3V66

$T_A = 0 - 70^\circ\text{C}$; $V_{DD} = 3.3\text{V} \pm 5\%$; $C_L = 10\text{-}30\text{ pF}$ (unless otherwise specified)

PARAMETER	SYMBOL	CONDITIONS	MIN	TYP	MAX	UNITS
Output Frequency	F_{O1}			66.66		MHz
Output Impedance	R_{DSP1}^1	$V_O = V_{DD}^*(0.5)$	12	33	55	Ω
Output High Voltage	V_{OH}^1	$I_{OH} = -1\text{ mA}$	2.4			V
Output Low Voltage	V_{OL}^1	$I_{OL} = 1\text{ mA}$			0.55	V
Output High Current	I_{OH}^1	$V_{OH} = 1.0\text{ V}$	-33			
		$V_{OH} = 3.135\text{ V}$			-33	mA
Output Low Current	I_{OL}^1	$V_{OL} = 1.95\text{ V}$	30			
		$V_{OL} = 0.4\text{ V}$			38	mA
Rise Time	t_{r1}^1	$V_{OL} = 0.4\text{ V}, V_{OH} = 2.4\text{ V}$	0.5		2	ns
Fall Time	t_{f1}^1	$V_{OH} = 2.4\text{ V}, V_{OL} = 0.4\text{ V}$	0.5		2	ns
Duty Cycle	d_{t1}^1	$V_T = 1.5\text{ V}$	45		55	%
Skew	t_{sk1}^1	$V_T = 1.5\text{ V}$			250	ps
Jitter	$t_{j\text{cyc-cyc}}^1$	$V_T = 1.5\text{ V}$ 3V66			250	ps

¹Guaranteed by design, not 100% tested in production.

Electrical Characteristics - PCICLK Mode

$T_A = 0 - 70^\circ\text{C}$; $V_{DD} = 3.3\text{V} \pm 5\%$; $C_L = 10\text{-}30\text{ pF}$ (unless otherwise specified)

PARAMETER	SYMBOL	CONDITIONS	MIN	TYP	MAX	UNITS
Output Frequency	F_{O1}					MHz
Output Impedance	R_{DSP1}^1	$V_O = V_{DD}^*(0.5)$	12	33	55	Ω
Output High Voltage	V_{OH}^1	$I_{OH} = -1\text{ mA}$	2.4			V
Output Low Voltage	V_{OL}^1	$I_{OL} = 1\text{ mA}$			0.55	V
Output High Current	I_{OH}^1	$V_{OH} = 1.0\text{ V}$	-33			
		$V_{OH} = 3.135\text{ V}$			-33	mA
Output Low Current	I_{OL}^1	$V_{OL} = 1.95\text{ V}$	30			
		$V_{OL} = 0.4\text{ V}$			38	mA
Rise Time	t_{r1}^1	$V_{OL} = 0.4\text{ V}, V_{OH} = 2.4\text{ V}$	0.5		0.5 to 2	ns
Fall Time	t_{f1}^1	$V_{OH} = 2.4\text{ V}, V_{OL} = 0.4\text{ V}$	0.5		0.5 to 2	ns
Duty Cycle	d_{t1}^1	$V_T = 1.5\text{ V}$	45		55	%
Skew	t_{sk1}^1	$V_T = 1.5\text{ V}$			500	ps
Jitter, cycle to cyc	$t_{j\text{cyc-cyc}}^1$	$V_T = 1.5\text{ V}$			500	ps

¹Guaranteed by design, not 100% tested in production.

Electrical Characteristics - VCH, 48MHz DOT, 48MHz, USB

$T_A = 0 - 70^\circ\text{C}$; $V_{DD}=3.3\text{V} \pm 5\%$; $C_L = 10\text{-}20 \text{ pF}$ (unless otherwise specified)

PARAMETER	SYMBOL	CONDITIONS	MIN	TYP	MAX	UNITS
Output Frequency	F_{O1}			48		MHz
Output Impedance	R_{DSP1}^1	$V_O = V_{DD}^*(0.5)$	20	48	60	Ω
Output High Voltage	V_{OH}^1	$I_{OH} = -1 \text{ mA}$	2.4			V
Output Low Voltage	V_{OL}^1	$I_{OL} = 1 \text{ mA}$			0.4	V
Output High Current	I_{OH}^1	$V_{OH} = 1.0 \text{ V}$	-29			
		$V_{OH} = 3.135 \text{ V}$			-23	mA
Output Low Current	I_{OL}^1	$V_{OL} = 1.95 \text{ V}$	27			
		$V_{OL} = 0.4 \text{ V}$			29	mA
48DOT Rise Time	t_{r1}^1	$V_{OL} = 0.4 \text{ V}, V_{OH} = 2.4 \text{ V}$	0.5		1	ns
48DOT Fall Time	t_{f1}^1	$V_{OH} = 2.4 \text{ V}, V_{OL} = 0.4 \text{ V}$	0.5		1	ns
VCH 48 USB Rise Time	t_{r1}^1	$V_{OL} = 0.4 \text{ V}, V_{OH} = 2.4 \text{ V}$	1		2	ns
VCH 48 USB Fall Time	t_{f1}^1	$V_{OH} = 2.4 \text{ V}, V_{OL} = 0.4 \text{ V}$	1		2	ns
48 DOT Duty Cycle	d_{t1}^1	$V_T = 1.5 \text{ V}$	45		55	%
VCH 48 USB Duty Cycle	d_{t1}^1	$V_T = 1.5 \text{ V}$	45		55	%
48 DOT Jitter	$t_{jycyc-cyc}^1$	$V_T = 1.5 \text{ V}$			350	ps
VCH Jitter	$t_{jycyc-cyc}^1$	$V_T = 1.5 \text{ V}$			350	ps

¹Guaranteed by design, not 100% tested in production.

Electrical Characteristics - REF

$T_A = 0 - 70^\circ\text{C}$; $V_{DD}=3.3\text{V} \pm 5\%$; $C_L = 10\text{-}20 \text{ pF}$ (unless otherwise specified)

PARAMETER	SYMBOL	CONDITIONS	MIN	TYP	MAX	UNITS
Output Frequency	F_{O1}					MHz
Output Impedance	R_{DSP1}^1	$V_O = V_{DD}^*(0.5)$	20	48	60	Ω
Output High Voltage	V_{OH}^1	$I_{OH} = -1 \text{ mA}$	2.4			V
Output Low Voltage	V_{OL}^1	$I_{OL} = 1 \text{ mA}$			0.4	V
Output High Current	I_{OH}^1	$V_{OH@MIN} = 1.0 \text{ V}, V_{OH@MAX} = 3.135 \text{ V}$	-29		-23	mA
Output Low Current	I_{OL}^1	$V_{OL@MIN} = 1.95 \text{ V}, V_{OL@MAX} = 0.4 \text{ V}$	29		27	mA
Rise Time	t_{r1}^1	$V_{OL} = 0.4 \text{ V}, V_{OH} = 2.4 \text{ V}$	1		2	ns
Fall Time	t_{f1}^1	$V_{OH} = 2.4 \text{ V}, V_{OL} = 0.4 \text{ V}$	1		2	ns
Duty Cycle	d_{t1}^1	$V_T = 1.5 \text{ V}$	45		55	%
Jitter	$t_{jycyc-cyc}^1$	$V_T = 1.5 \text{ V}$			1000	ps

¹Guaranteed by design, not 100% tested in production.

Shared Pin Operation - Input/Output Pins

The I/O pins designated by (input/output) serve as dual signal functions to the device. During initial power-up, they act as input pins. The logic level (voltage) that is present on these pins at this time is read and stored into a 5-bit internal data latch. At the end of Power-On reset, (see AC characteristics for timing values), the device changes the mode of operations for these pins to an output function. In this mode the pins produce the specified buffered clocks to external loads.

To program (load) the internal configuration register for these pins, a resistor is connected to either the VDD (logic 1) power supply or the GND (logic 0) voltage potential. A 10 Kiloohm (10K) resistor is used to provide both the solid CMOS programming voltage needed during the power-up programming period and to provide an insignificant load on the output clock during the subsequent operating period.

Figure 1 shows a means of implementing this function when a switch or 2 pin header is used. With no jumper is installed the pin will be pulled high. With the jumper in place the pin will be pulled low. If programmability is not necessary, than only a single resistor is necessary. The programming resistors should be located close to the series termination resistor to minimize the current loop area. It is more important to locate the series termination resistor close to the driver than the programming resistor.

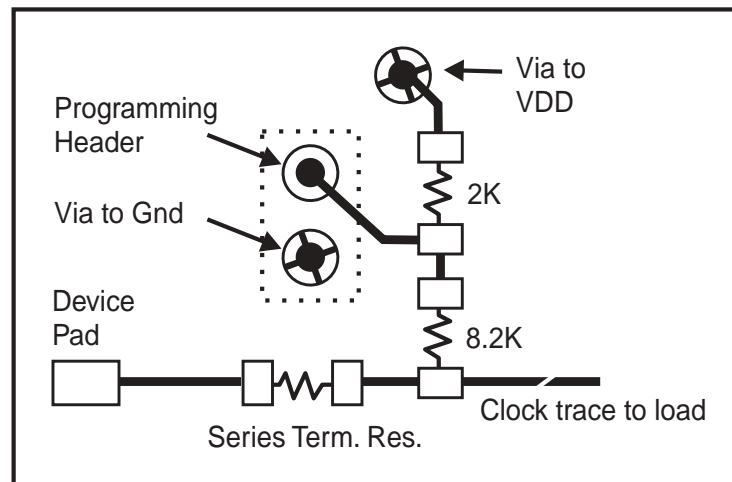
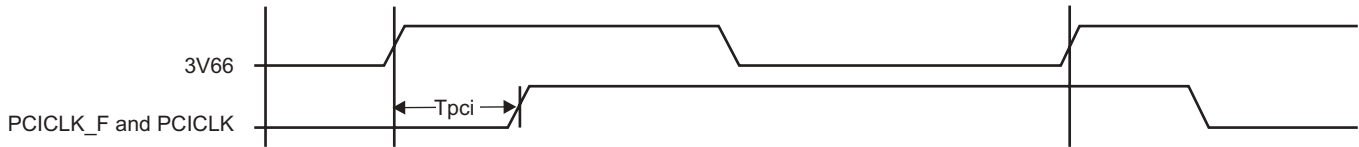

Fig. 1

Un-Buffered Mode 3V66 & PCI Phase Relationship

All 3V66 clocks are to be in pphase with each other. In the case where 3V66_1 is configured as 48MHz VCH clock, there is no defined phase relationship between 3V66_1/VCH and other 3V66 clocks. The PCI group should lag 3V66 by the standard skew described below as T_{pci} .



Group Skews at Common Transition Edges

GROUP	SYMBOL	CONDITIONS	MIN	TYP	MAX	UNITS
3V66	3V66	3V66 (5:0) pin to pin skew	0		250	ps
PCI	PCI	PCI_F (2:0) and PCI (6:0) pin to pin skew	0		500	ps
3V66 to PCI	$S_{3V66-PCI}$	3V66 (5:0) leads 33MHz PCI	1.5		3.5	ns

¹Guaranteed by design, not 100% tested in production.

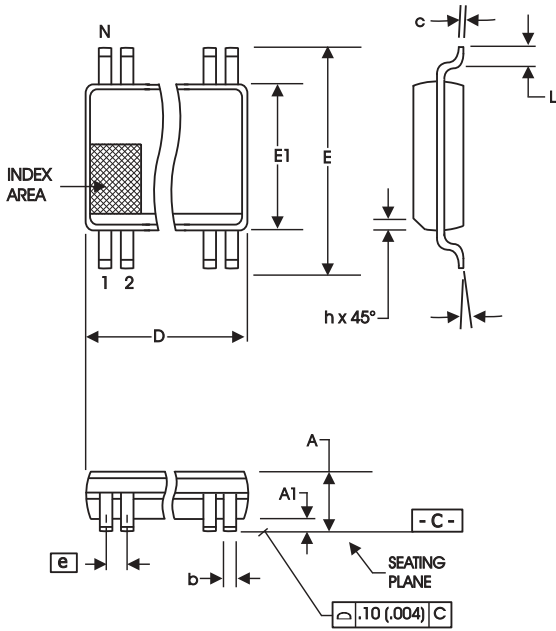

300 mil SSOP Package

SYMBOL	In Millimeters		In Inches	
	COMMON DIMENSIONS		COMMON DIMENSIONS	
	MIN	MAX	MIN	MAX
A	2.41	2.80	.095	.110
A1	0.20	0.40	.008	.016
b	0.20	0.34	.008	.0135
c	0.13	0.25	.005	.010
D	SEE VARIATIONS		SEE VARIATIONS	
E	10.03	10.68	.395	.420
E1	7.40	7.60	.291	.299
e	0.635 BASIC		0.025 BASIC	
h	0.38	0.64	.015	.025
L	0.50	1.02	.020	.040
N	SEE VARIATIONS		SEE VARIATIONS	
α	0°	8°	0°	8°

VARIATIONS

N	D mm.		D (inch)	
	MIN	MAX	MIN	MAX
48	15.75	16.00	.620	.630

Reference Doc.: JEDEC Publication 95, MO-118

10-0034

Ordering Information

ICS950218yFLF-T

Example:

ICS XXXX y F LF-T

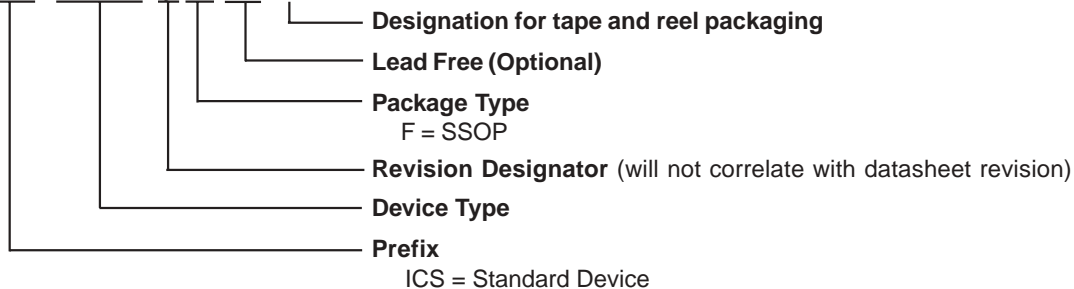

IMPORTANT NOTICE AND DISCLAIMER

RENESAS ELECTRONICS CORPORATION AND ITS SUBSIDIARIES (“RENESAS”) PROVIDES TECHNICAL SPECIFICATIONS AND RELIABILITY DATA (INCLUDING DATASHEETS), DESIGN RESOURCES (INCLUDING REFERENCE DESIGNS), APPLICATION OR OTHER DESIGN ADVICE, WEB TOOLS, SAFETY INFORMATION, AND OTHER RESOURCES “AS IS” AND WITH ALL FAULTS, AND DISCLAIMS ALL WARRANTIES, EXPRESS OR IMPLIED, INCLUDING, WITHOUT LIMITATION, ANY IMPLIED WARRANTIES OF MERCHANTABILITY, FITNESS FOR A PARTICULAR PURPOSE, OR NON-INFRINGEMENT OF THIRD-PARTY INTELLECTUAL PROPERTY RIGHTS.

These resources are intended for developers who are designing with Renesas products. You are solely responsible for (1) selecting the appropriate products for your application, (2) designing, validating, and testing your application, and (3) ensuring your application meets applicable standards, and any other safety, security, or other requirements. These resources are subject to change without notice. Renesas grants you permission to use these resources only to develop an application that uses Renesas products. Other reproduction or use of these resources is strictly prohibited. No license is granted to any other Renesas intellectual property or to any third-party intellectual property. Renesas disclaims responsibility for, and you will fully indemnify Renesas and its representatives against, any claims, damages, costs, losses, or liabilities arising from your use of these resources. Renesas' products are provided only subject to Renesas' Terms and Conditions of Sale or other applicable terms agreed to in writing. No use of any Renesas resources expands or otherwise alters any applicable warranties or warranty disclaimers for these products.

(Disclaimer Rev.1.01 Jan 2024)

Corporate Headquarters

TOYOSU FORESIA, 3-2-24 Toyosu,
Koto-ku, Tokyo 135-0061, Japan
www.renesas.com

Trademarks

Renesas and the Renesas logo are trademarks of Renesas Electronics Corporation. All trademarks and registered trademarks are the property of their respective owners.

Contact Information

For further information on a product, technology, the most up-to-date version of a document, or your nearest sales office, please visit www.renesas.com/contact-us/.

Looking for pricing, stock, or lifecycle information?

Click below to explore more details on WIN SOURCE:

-  [View ICS950218AFLFT on WIN SOURCE](#)
-  [Renesas Electronics America](#) Information

Optimize Your Supply Chain with WIN SOURCE Solutions

-  Global Sourcing Solution
-  Obsolete Management
-  Cost Control Management
-  Shortage Management
-  Alternative Solution
-  Excess Inventory Management