



**THE DATASHEET OF
ICL7631BCSE**



ICL761X–ICL764X

Single/Dual/Triple/Quad Operational Amplifiers

General Description

The ICL761X–ICL764X family of monolithic CMOS op amps combine ultra-low input current with low-power operation over a wide supply voltage range. With pin-selectable quiescent currents of 10µA, 100µA, or 1000µA per amplifier, these op amps will operate from ±1V to ±8V power supplies, or from single supplies from 2V to 16V. The CMOS outputs swing to within milli-volts of the supply voltages.

The ultra-low bias current of 1pA makes this family of op amps ideal for long time constant integrators, picoammeters, low droop rate sample/hold amplifiers and other applications where input bias and offset currents are critical. A low noise current of $0.01\text{pA}\sqrt{\text{Hz}}$ and an input impedance of $10^{12}\Omega$ ensure optimum performance with very high source impedances in such applications as pH meters and photodiode amplifiers.

Applications

- Battery-Powered Instruments
- Low-Leakage Amplifiers
- Long-Time Constant Integrators
- Low-Frequency Active Filters
- Hearing Aids and Microphone Amplifiers
- Low Droop Rate Sample/Hold Amplifiers
- Picoammeters

Pin Configuration

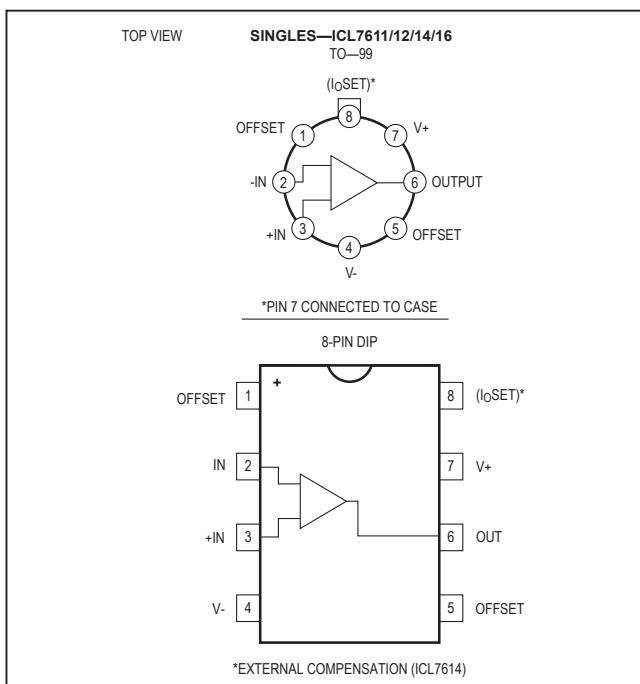

Features

- Pin-for-Pin Second Source
- 1pA Typical Bias Current—4nA (max) at +125°C
- ±1V to ±8V Wide Supply Voltage Range
- Industry-Standard Pinouts
- Programmable Quiescent Currents of 10µA, 100µA, and 1000µA
- Monolithic, Low-Power CMOS Design

Ordering Information

ICL76XX	M	N	OP
	V _{OS} SELECTION	TEMP RANGE	PKG CODE
	A = 2mV	C = 0°C to 70°C	TV= 8-Pin TO-99
	B = 5mV	E = -40°C to +85°C	PA = 8-Pin Plastic Dip
	C = 10mV	M = -55°C to +125°C	SA = 8-Pin Small SO
	D = 15mV		JD = 14-Pin Cerdip
	E = 20mV		PD = 14-Pin Plastic Dip
			SD = 14-Pin Small SO
			JE = 16-Pin Cerdip
			PE = 16-Pin Plastic Dip
			SE = 16-Pin Small SO
			WE = 16-Pin Wide SO

Typical Operating Circuit appears at end of data sheet.

ICL761X–ICL764X

Single/Dual/Triple/Quad Operational Amplifiers

Ordering Information (continued)

	ICL7611	ICL7612	ICL7614	ICL7616	ICL7621	ICL7622	ICL7631	ICL7632	ICL7641	ICL7642
Compensated	X	X		X	X	X	X		X	X
Externally Compensated			X							
Extended CMVR		X		X						
Offset null capability	X	X	X	X		X				
Programmable I_Q	X	X		X			X	X		
Fixed I_Q -10 μ A										X
Fixed I_Q -100 μ A			X		X	X				
Fixed I_Q -1mA										X

Ordering Information (Single/Dual)

PART	TEMP RANGE	PIN-PACKAGE
ICL761X ACPA	0°C to +70°C	8 Plastic Dip
ICL761XACSA	0°C to +70°C	8 Slim SO
ICL761XACTV	0°C to +70°C	TO-99 Metal Can
ICL761XAMTV	-55°C to +125°C	TO-99 Metal Can
ICL761XBCPA	0°C to +70°C	8 Plastic Dip
ICL761XBCSA	0°C to +70°C	8 Slim SO
ICL761XBCTV	0°C to +70°C	TO-99 Metal Can
ICL761XBESA	-40°C to +85°C	8 Slim SO
ICL761XBMTV	-55°C to +125°C	TO-99 Metal Can
ICL761XD CPA	0°C to +70°C	8 Plastic Dip
ICL761XD CSA	0°C to +70°C	8 Slim SO
ICL761XDCTV	0°C to +70°C	TO-99 Metal Can
ICL761XD ESA	-40°C to +85°C	8 Slim SO
ICL7621 ACPA	0°C to +70°C	8 Plastic Dip
ICL7621ACSA	0°C to +70°C	8 Slim SO
ICL7621ACTV	0°C to +70°C	TO-99 Metal Can
ICL7621AMTV	-55°C to +125°C	TO-99 Metal Can
ICL7621BCPA	0°C to +70°C	8 Plastic Dip

Note: X above is replaced by: 1, 2, 4, 8.

PART	TEMP RANGE	PIN-PACKAGE
ICL7621BCSA	0°C to +70°C	8 Slim SO
ICL7621BCTV	0°C to +70°C	TO-99 Metal Can
ICL7621BMTV	-55°C to +125°C	TO-99 Metal Can
ICL7621DCPA	0°C to +70°C	8 Plastic Dip
ICL7621DCSA	0°C to +70°C	8 Slim SO
ICL7621DCTV	0°C to +70°C	TO-99 Metal Can
ICL7621DESA+	-40°C to +85°C	8 Slim SO
ICL7622 ACPD	0°C to +70°C	14 Plastic Dip
ICL7622ACSD	0°C to +70°C	14 Slim SO
ICL7622ACJD	0°C to +70°C	14 CERDIP
ICL7622AMJD	-55°C to +125°C	14 CERDIP
ICL7622BCPD	0°C to +70°C	14 Plastic Dip
ICL7622BCSA	0°C to +70°C	14 Slim SO
ICL7622BCJD	0°C to +70°C	14 CERDIP
ICL7622BMJD	-55°C to +125°C	14 CERDIP
ICL7622DCPD	0°C to +70°C	14 Plastic Dip
ICL7622DCSD	0°C to +70°C	14 Slim SO
ICL7622DCJD	0°C to +70°C	14 CERDIP

Pin Configurations

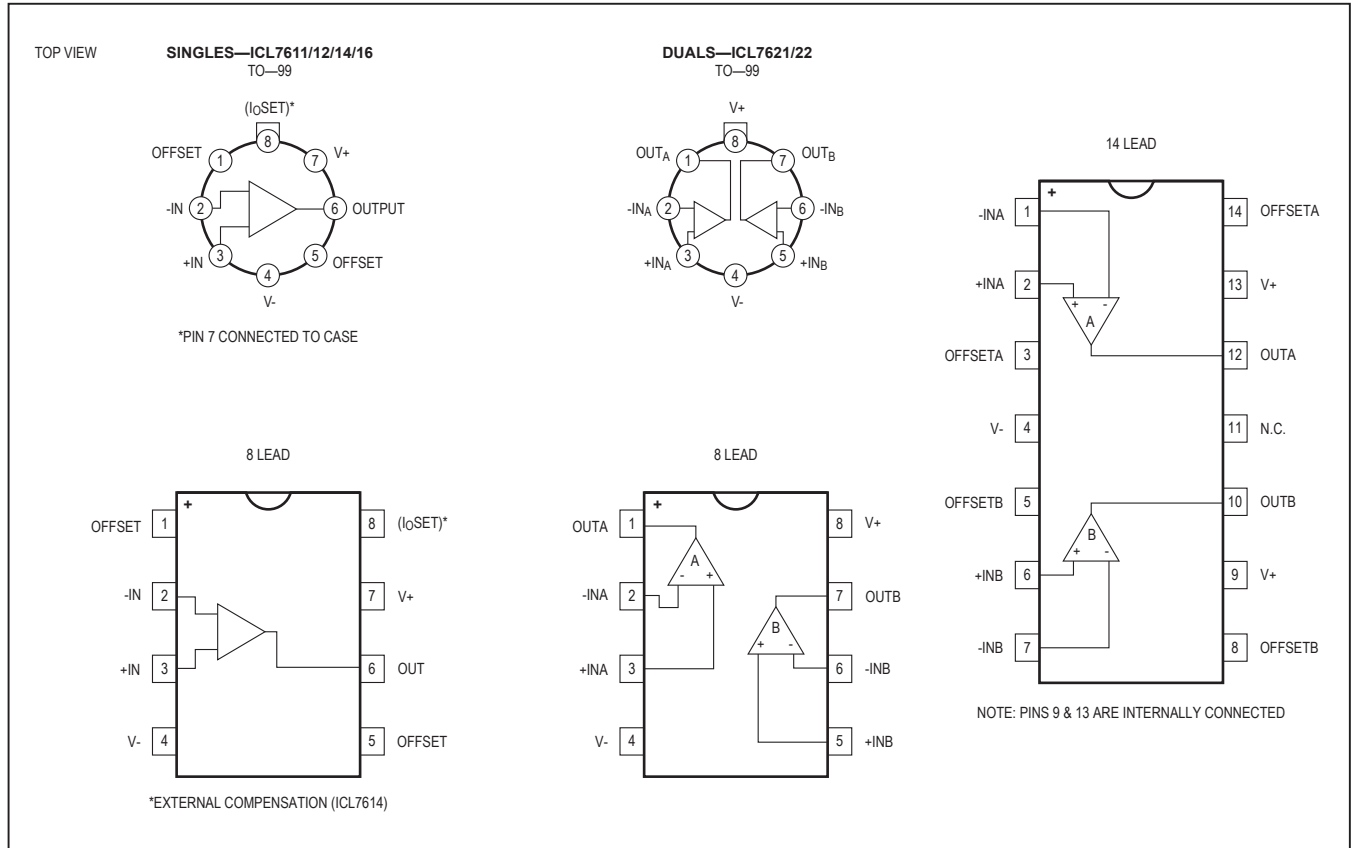

Absolute Maximum Ratings (Single/Dual)

Total Supply Voltage (V+ to V-)+18V
 Input Voltage(V+ + 0.3V) to (V- - 0.3V)
 Differential Input Voltage (Note 1)±(V+ + 0.3V) to (V- - 0.3V)
 Duration of Output Short Circuit (Note 2) Unlimited
 Continuous Power Dissipation (T_A = +25°C)
 TO-99 Metal Can (derate 2mW/°C above +25°C)250mW
 8-Pin Minidip (derate 2mW/°C above +25°C)250mW
 14-Pin Plastic (derate 3mW/°C above +25°C)375mW
 14-Pin CERDIP (derate 4mW/°C above +25°C)500mW
 16-Pin Plastic (derate 3mW/°C above +25°C)375mW
 16-Pin CERDIP (derate 4mW/°C above +25°C)500mW

Operating Temperature Ranges:

M Series -55°C to +125°C
 E Series -40°C to +85°C
 C Series -0°C to +70°C
 Storage Temperature Range -55°C to +150°C
 Lead Temperature (soldering, 10s) +300°C
 Soldering Temperature (reflow)
 Lead(Pb)-Free Packages +260°C
 Packages Containing Lead..... +240°C

Stresses beyond those listed under “Absolute Maximum Ratings” may cause permanent damage to the device. These are stress ratings only, and functional operation of the device at these or any other conditions beyond those indicated in the operational sections of the specifications is not implied. Exposure to absolute maximum rating conditions for extended periods may affect device reliability.

Note 1: Long-term offset voltage stability will be degraded if large input differential voltages are applied for long periods of time.

Note 2: The outputs may be shorted to ground or to either supply for V_{SUPP} ≤ 10V. Care must be taken to insure that the dissipation rating is not exceeded.

Electrical Characteristics (Single/Dual)

(V_{SUPP} = ±1.0V, I_Q = 10µA, T_A = +25°C, unless otherwise noted.)

PARAMETER	SYMBOL	CONDITIONS	ICL76XXA			ICL76XXB			UNITS	
			MIN	TYP	MAX	MIN	TYP	MAX		
Input Offset Voltage	V _{OS}	R _S ≤ 100kΩ, T _A = +25°C			2			5	mV	
		R _S ≤ 100kΩ, T _{MIN} ≤ T _A ≤ T _{MAX}			3			7		
Temperature Coefficient of V _{OS}	ΔV _{OS} /ΔT	R _S ≤ 100kΩ		10			15		µV/°C	
Input Offset Current	I _{OS}	T _A = +25°C		0.5	30		0.5	30	pA	
		0°C ≤ T _A ≤ +70°C			300			300		
Input Bias Current	I _{BIAS}	T _A = +25°C		1.0	50		1.0	50	pA	
		0°C ≤ T _A ≤ +70°C			500			500		
Common-Mode Voltage Range (Except ICL7612/ICL7616)	V _{CMR}		-0.4		+0.6	-0.4		+0.6	V	
Extended Common-Mode Voltage Range (ICL7612 Only)	V _{CMR}		-1.1		+0.6	-1.1		+0.6	V	
Extended Common-Mode Voltage Range (ICL7616 Only)	V _{CMR}	I _Q = 10µA	-1.3		-0.3	-1.3		-0.3	V	
Output Voltage Swing	V _{OUT}	R _L = 1MΩ, T _A = +25°C		±0.98				±0.98		V
		R _L = 1MΩ, 0°C ≤ T _A ≤ +70°C		±0.96				±0.96		

Electrical Characteristics (Single/Dual) (continued)

(V_{SUPP} = ±1.0V, I_Q = 10µA, T_A = +25°C, unless otherwise noted.)

PARAMETER	SYMBOL	CONDITIONS	ICL76XXA			ICL76XXB			UNITS
			MIN	TYP	MAX	MIN	TYP	MAX	
Large-Signal Voltage Gain	A _{VOL}	V _O = ±0.1V, R _L = 1MΩ, T _A = +25°C		90			90		dB
		V _O = ±0.1V, R _L = 1MΩ, 0°C ≤ T _A ≤ +70°C		80			80		
Unity-Gain Bandwidth	GBW			0.044			0.044		MHz
Input Resistance	R _{IN}			10 ¹²			10 ¹²		Ω
Common-Mode Rejection Ratio	CMRR	R _S ≤ 100kΩ		80			80		dB
Power-Supply Rejection Ratio	PSRR	R _S ≤ 100kΩ		80			80		dB
Input-Referred Noise Voltage	e _n	R _S = 100Ω, f = 1kHz		100			100		nV/√Hz
Input-Referred Noise Current	i _n	R _S = 100Ω, f = 1kHz		0.01			0.01		pA/√Hz
Supply Current (Per Amplifier)	I _{SUPP}	No signal, no load		6	15		6	15	µA
Slew Rate	SR	A _{VOL} = 1, C _L = 100pF, V _{IN} = 0.2V _{P-P} , R _L = 1MΩ		0.016			0.016		V/µs
Rise Time	t _r	V _{IN} = 50mV, C _L = 100pF, R _L = 1MΩ		20			20		µs
Overshoot Factor		V _{IN} = 50mV, C _L = 100pF, R _L = 1MΩ		5			5		%

Electrical Characteristics (Single/Dual)

(V_{SUPP} = ±5.0V, T_A = +25°C, unless otherwise noted.)

PARAMETER	SYMBOL	CONDITIONS	ICL76XXA			ICL76XXB			ICL76XXD			UNITS
			MIN	TYP	MAX	MIN	TYP	MAX	MIN	TYP	MAX	
Input Offset Voltage	V _{OS}	R _S ≤ 100kΩ, T _A = +25°C		2			5			15	mV	
		R _S ≤ 100kΩ, T _{MIN} ≤ T _A ≤ T _{MAX}		3			7			20		
Temperature Coefficient of V _{OS}	ΔV _{OS} /ΔT	R _S ≤ 100kΩ		10			15			25	µV/°C	
Input Offset Current	I _{OS}	T _A = +25°C		0.5	30		0.5	30		0.5	30	pA
		C: 0°C ≤ T _A ≤ +70°C		300			300			300		
		E: -40°C ≤ T _A ≤ +85°C		800			800			800		
		M: -55°C ≤ T _A ≤ +125°C		800			800			800		

Electrical Characteristics (Single/Dual) (continued)

(V_{SUPP} = ±5.0V, T_A = +25°C, unless otherwise noted.)

PARAMETER	SYMBOL	CONDITIONS	ICL76XXA			ICL76XXB			ICL76XXD			UNITS
			MIN	TYP	MAX	MIN	TYP	MAX	MIN	TYP	MAX	
Input Bias Current	I _{BIAS}	T _A = +25°C	1.0	50		1.0	50		1.0	50		pA
		C: 0°C ≤ T _A ≤ +70°C			400			400			400	
		E: -40°C ≤ T _A ≤ +85°C			4000			4000			4000	
		M: -55°C ≤ T _A ≤ +125°C			4000			4000			4000	
Common-Mode Voltage Range (Except ICL7612/ICL7616)	V _{CMR}	I _Q = 10µA (Note 3)	+4.4			+4.4			+4.4			V
			-4.0			-4.0			-4.0			
		I _Q = 100µA (Note 3)	+4.2			+4.2			+4.2			
			-4.0			-4.0			-4.0			
		I _Q = 1mA (Note 3)	+3.7			+3.7			+3.7			
			-3.7			-3.7			-3.7			
Extended Common-Mode Voltage Range (ICL7612 Only)	V _{CMR}	I _Q = 10µA	±5.3			±5.3			±5.3			V
			+5.3			+5.3			+5.3			
		I _Q = 100µA	-5.1			-5.1			-5.1			
			+5.3			+5.3			+5.3			
		I _Q = 1mA	-4.5			-4.5			-4.5			
			+5.3			+5.3			+5.3			
Extended Common-Mode Voltage Range (ICL7616 Only)	V _{CMR}	I _Q = 10µA	-5.3			-5.3			-5.3			V
			+3.7			+3.7			+3.5			
		I _Q = 100µA	-5.1			-5.1			-5.1			
			+3.0			+3.0			+2.7			
		I _Q = 1mA	-4.5			-4.5			-4.5			
			+2.0			+2.0			+1.7			

Electrical Characteristics (Single/Dual) (continued)

(V_{SUPP} = ±5.0V, T_A = +25°C, unless otherwise noted.)

PARAMETER	SYMBOL	CONDITIONS	ICL76XXA			ICL76XXB			ICL76XXD			UNITS	
			MIN	TYP	MAX	MIN	TYP	MAX	MIN	TYP	MAX		
Output Voltage Swing	V _{OUT}	I _Q = 10µA, R _L = 1MΩ (Note 3)	T _A = +25°C	±4.9			±4.9			±4.9			V
			C: 0°C ≤ T _A ≤ +70°C	±4.8			±4.8			±4.8			
			E: -40°C ≤ T _A ≤ +85°C	±4.7			±4.7			±4.7			
			M: -55°C ≤ T _A ≤ +125°C	±4.7			±4.7			±4.7			
		I _Q = 100µA, R _L = 100kΩ	T _A = +25°C	±4.9			±4.9			±4.9			
			C: 0°C ≤ T _A ≤ +70°C	±4.8			±4.8			±4.8			
			E: -40°C ≤ T _A ≤ +85°C	±4.5			±4.5			±4.5			
			M: -55°C ≤ T _A ≤ +125°C	±4.5			±4.5			±4.5			
		I _Q = 1mA, R _L = 10kΩ (Note 3)	T _A = +25°C	±4.5			±4.5			±4.5			
			C: 0°C ≤ T _A ≤ +70°C	±4.3			±4.3			±4.3			
			E: -40°C ≤ T _A ≤ +85°C	±4.0			±4.0			±4.0			
			M: -55°C ≤ T _A ≤ +125°C	±4.0			±4.0			±4.0			

Electrical Characteristics (Single/Dual) (continued)

($V_{SUPP} = \pm 5.0V$, $T_A = +25^\circ C$, unless otherwise noted.)

PARAMETER	SYMBOL	CONDITIONS	ICL76XXA			ICL76XXB			ICL76XXD			UNITS
			MIN	TYP	MAX	MIN	TYP	MAX	MIN	TYP	MAX	
Large-Signal Voltage Gain	A_{VOL}	$V_O = \pm 4.0V$ $R_L = 1M\Omega$, $I_Q = 10\mu A$	$T_A = +25^\circ C$	86	104		80	104		80	104	dB
			C: $0^\circ C \leq T_A \leq +70^\circ C$	80			75			75		
			E: $-40^\circ C \leq T_A \leq +85^\circ C$	74			68			68		
			M: $-55^\circ C \leq T_A \leq +125^\circ C$	74			68			68		
		$V_O = \pm 4.0V$, $R_L = 100k\Omega$, $I_Q = 100\mu A$	$T_A = +25^\circ C$	86	102		80	102		80	102	
			C: $0^\circ C \leq T_A \leq +70^\circ C$	80			75			75		
			E: $-40^\circ C \leq T_A \leq +85^\circ C$	74			68			68		
			M: $-55^\circ C \leq T_A \leq +125^\circ C$	74			68			68		
		$V_O = \pm 4.0V$, $R_L = 10k\Omega$, $I_Q = 1mA$ (Note 3)	$T_A = +25^\circ C$	80	83		76	83		76	83	
			C: $0^\circ C \leq T_A \leq +70^\circ C$	76			72			72		
			E: $-40^\circ C \leq T_A \leq +85^\circ C$	72			68			68		
			M: $-55^\circ C \leq T_A \leq +125^\circ C$	72			68			68		

Electrical Characteristics (Single/Dual) (continued)

(V_{SUPP} = ±5.0V, T_A = +25°C, unless otherwise noted.)

PARAMETER	SYMBOL	CONDITIONS	ICL76XXA			ICL76XXB			ICL76XXD			UNITS
			MIN	TYP	MAX	MIN	TYP	MAX	MIN	TYP	MAX	
Unity-Gain Bandwidth	GBW	I _Q = 10μA (Note 3)	0.044			0.044			0.044			MHz
		I _Q = 100μA	0.48			0.48			0.48			
		I _Q = 1mA (Note 3)	1.4			1.4			1.4			
Input Resistance	R _{IN}		1012			1012			1012			Ω
Common-Mode Rejection Ratio	CMRR	R _S ≤ 100kΩ, I _Q = 10μA (Note 3)	76	96		70	96		70	96		dB
		R _S ≤ 100kΩ, I _Q = 100μA	76	91		70	91		70	91		
		R _S ≤ 100kΩ, I _Q = 1mA (Note 3)	66	87		60	87		60	87		
Power-Supply Rejection Ratio	PSRR	R _S ≤ 100kΩ, I _Q = 10μA (Note 3)	80	94		80	94		80	94		dB
		R _S ≤ 100kΩ, I _Q = 100μA	80	86		80	86		80	86		
		R _S ≤ 100kΩ, I _Q = 1mA (Note 3)	70	77		70	77		70	77		
Input-Referred Noise Voltage	e _n	R _S = 100Ω, f = 1kHz	100			100			100			nV/√Hz
Input-Referred Noise Current	i _n	R _S = 100Ω, f = 1kHz	0.01			0.01			0.01			pA/√Hz
Supply Current (Per Amplifier)	I _{SUPP}	No signal, no load	I _Q = 10μA (Note 3)	0.01	0.02		0.01	0.02		0.01	0.02	mA
			I _Q = 100μA	0.1	0.25		0.1	0.25		0.1	0.25	
			I _Q = 1mA (Note 3)	1.0	2.5		1.0	2.5		1.0	2.5	
Channel Separation	V _{O1} / V _{O2}	AVOL = 100	120			120			120			dB

Electrical Characteristics (Single/Dual) (continued)

(V_{SUPP} = ±5.0V, T_A = +25°C, unless otherwise noted.)

PARAMETER	SYMBOL	CONDITIONS	ICL76XXA			ICL76XXB			ICL76XXD			UNITS	
			MIN	TYP	MAX	MIN	TYP	MAX	MIN	TYP	MAX		
Slew Rate (Note 4)	SR	A _{VOL} = 1, C _L = 100pF, V _{IN} = 8V _{P-P}	I _Q = 10μA (Note 3), R _L = 1MΩ	0.016			0.016			0.016			V/μs
			I _Q = 100μA, R _L = 100kΩ	0.16			0.16			0.16			
			I _Q = 1mA (Note 3), R _L = 10kΩ	1.6			1.6			1.6			
Rise Time (Note 4)	t _r	V _{IN} = 50mV, C _L = 100pF	I _Q = 10μA (Note 3), R _L = 1MΩ	20			20			20			μs
			I _Q = 100μA, R _L = 100kΩ	2			2			2			
			I _Q = 1mA (Note 3), R _L = 10kΩ	0.9			0.9			0.9			
Overshoot Factor (Note 4)		V _{IN} = 50mV, C _L = 100pF	I _Q = 10μA (Note 3), R _L = 1MΩ	5			5			5			%
			I _Q = 100μA, R _L = 100kΩ	10			10			10			
			I _Q = 1mA (Note 3), R _L = 10kΩ	40			40			40			

Note 3: AICL7611, ICL7612, ICL7616 only.

Note 4: ICL7814; 39pF from pin 6 to pin 8.

Ordering Information (Triple/Quad)

PART	TEMP RANGE	PIN-PACKAGE
ICL763XBCPE	0°C to +70°C	16 Plastic Dip
ICL763XBCSE	0°C to +70°C	16 Slim SO
ICL763XCCPE	0°C to +70°C	16 Plastic Dip
ICL763XCCSE	0°C to +70°C	16 Slim SO
ICL763XECPE	0°C to +70°C	16 Plastic Dip
ICL763XECSE	0°C to +70°C	16 Slim SO
ICL763XBCJE	0°C to +70°C	16 CERDIP
ICL763XCCJE	0°C to +70°C	16 CERDIP
ICL763XECJE	0°C to +70°C	16 CERDIP
ICL763XBMJE	-55°C to +125°C	16 CERDIP
ICL763XCMJE	-55°C to +125°C	16 CERDIP

PART	TEMP RANGE	PIN-PACKAGE
ICL764XBCPD	0°C to +70°C	14 Plastic Dip
ICL764XBCWE	0°C to +70°C	16 Wide SO
ICL764XCCPD	0°C to +70°C	14 Plastic Dip
ICL764XCCWE	0°C to +70°C	16 Wide SO
ICL764XECPD	0°C to +70°C	14 Plastic Dip
ICL764XECWE	0°C to +70°C	16 Wide SO
ICL764XBCJD	0°C to +70°C	14 CERDIP
ICL764XCCJD	0°C to +70°C	14 CERDIP
ICL764XECJD	0°C to +70°C	14 CERDIP
ICL764XBMJD	-55°C to +125°C	14 CERDIP
ICL764XCMJD	-55°C to +125°C	14 CERDIP

Note: X above is replaced by: 1, 2.

Pin Configurations

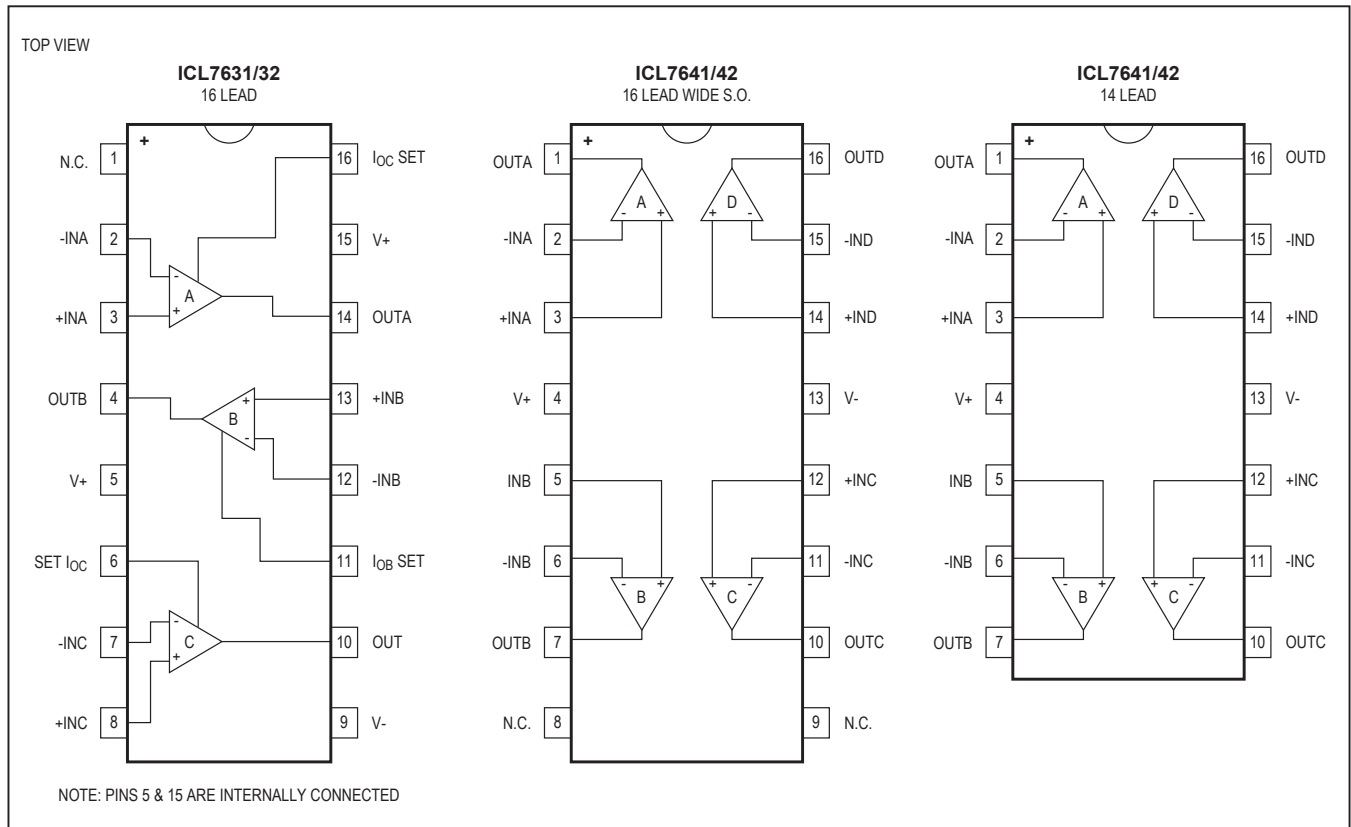

Absolute Maximum Ratings (Triple/Quad)

Total Supply Voltage (V+ to V-)	+18V	16-Pin Plastic (derate 3mW/°C above +25°C)	375mW
Input Voltage	(V+ + 0.3V) to (V- - 0.3V)	16-Pin CERDIP (derate 4mW/°C above +25°C)	500mW
Differential Input Voltage (Note 5)	$\pm[(V+ + 0.3V) - (V- - 0.3V)]$	Operating Temperature Ranges:	
Duration of Output Short Circuit (Note 6)	Unlimited	M Series	-55°C to +125°C
Continuous Power Dissipation (T _A = +25°C)		E Series	-40°C to +85°C
TO-99 Metal Can (derate 2mW/°C above +25°C)	250mW	C Series	-0°C to +70°C
8-Pin Minidip (derate 2mW/°C above +25°C)	250mW	Storage Temperature Range	-55°C to +150°C
14-Pin Plastic (derate 3mW/°C above +25°C)	375mW	Lead Temperature (soldering, 10s)	+300°C
14-Pin CERDIP (derate 4mW/°C above +25°C)	500mW		

Stresses beyond those listed under “Absolute Maximum Ratings” may cause permanent damage to the device. These are stress ratings only, and functional operation of the device at these or any other conditions beyond those indicated in the operational sections of the specifications is not implied. Exposure to absolute maximum rating conditions for extended periods may affect device reliability.

Note 5: Long-term offset voltage stability will be degraded if large input differential voltages are applied for long periods of time.

Note 6: The outputs may be shorted to ground or to either supply for V_{SUPP} ≤ 10V. Care must be taken to insure that the dissipation rating is not exceeded.

Electrical Characteristics (Triple/Quad)

(V_{SUPP} = ±1.0V, I_Q = 10μA, T_A = +25°C, unless otherwise noted.) (Specifications apply to ICL7631/7632/7642 only.)

PARAMETER	SYMBOL	CONDITIONS	ICL76XXB			ICL76XXC			UNITS
			MIN	TYP	MAX	MIN	TYP	MAX	
Input Offset Voltage	V _{OS}	R _S ≤ 100kΩ, T _A = +25°C			5			10	mV
		R _S ≤ 100kΩ, T _{MIN} ≤ T _A ≤ T _{MAX}			7			12	
Temperature Coefficient of V _{OS}	ΔV _{OS} /ΔT	R _S ≤ 100kΩ		15			20		μV/°C
Input Offset Current	I _{OS}	T _A = +25°C		0.5	30		0.5	30	pA
		0°C ≤ T _A ≤ +70°C			300			300	
Input Bias Current	I _{BIAS}	T _A = +25°C		1.0	50		1.0	50	pA
		0°C ≤ T _A ≤ +70°C			500			500	
Common-Mode Voltage Range	V _{CMR}		-0.4		+0.6	-0.4		+0.6	V
Output Voltage Swing	V _{OUT}	R _L = 1MΩ, T _A = +25°C		±0.98			±0.98		V
		R _L = 1MΩ, 0°C ≤ T _A ≤ +70°C		±0.96			±0.96		
Large-Signal Voltage Gain	A _{VOL}	V _O = ±0.1V, R _L = 1MΩ, T _A = +25°C		90			90		dB
		V _O = ±0.1V, R _L = 1MΩ, 0°C ≤ T _A ≤ +70°C		80			80		
Unity-Gain Bandwidth	GBW			0.044			0.044		MHz
Input Resistance	R _{IN}			10 ¹²			10 ¹²		Ω
Common-Mode Rejection Ratio	CMRR	R _S ≤ 100kΩ		80			80		dB

Electrical Characteristics (Triple/Quad) (continued)

($V_{SUPP} = \pm 1.0V$, $I_Q = 10\mu A$, $T_A = +25^\circ C$, unless otherwise noted.) (Specifications apply to ICL7631/7632/7642 only.)

PARAMETER	SYMBOL	CONDITIONS	ICL76XXB			ICL76XXC			UNITS
			MIN	TYP	MAX	MIN	TYP	MAX	
Power-Supply Rejection Ratio	PSRR			80			80		dB
Input-Referred Noise Voltage	e_n	$R_S = 100\Omega$, $f = 1kHz$		100			100		nV/\sqrt{Hz}
Input-Referred Noise Current	i_n	$R_S = 100\Omega$, $f = 1kHz$		0.01			0.01		pA/\sqrt{Hz}
Supply Current (Per Amplifier)	I_{SUPP}	No signal, no load		6	15		6	15	μA
Channel Separation	V_{O1} / V_{O2}	$A_{VOL} = 100$		120			120		dB
Slew Rate	SR	$A_{VOL} = 1$, $C_L = 100pF$, $V_{IN} = 0.2V_{P-P}$, $R_L = 1M\Omega$		0.016			0.016		$V/\mu s$
Rise Time	t_r	$V_{IN} = 50mV$, $C_L = 100pF$, $R_L = 1M\Omega$		20			20		μs
Overshoot Factor		$V_{IN} = 50mV$, $C_L = 100pF$, $R_L = 1M\Omega$		5			5		%

Electrical Characteristics (Triple/Quad)

($V_{SUPP} = \pm 5.0V$, $T_A = +25^\circ C$, unless otherwise noted.)

PARAMETER	SYMBOL	CONDITIONS	ICL76XXB			ICL76XXC			ICL76XXE			UNITS
			MIN	TYP	MAX	MIN	TYP	MAX	MIN	TYP	MAX	
Input Offset Voltage	V_{OS}	$R_S \leq 100k\Omega$, $T_A = +25^\circ C$		5			10			20	mV	
		$R_S \leq 100k\Omega$, $T_{MIN} \leq T_A \leq T_{MAX}$		7			15			25		
Temperature Coefficient of V_{OS}	$\Delta V_{OS}/\Delta T$	$R_S \leq 100k\Omega$		15			20			30	$\mu V/^\circ C$	
Input Offset Current	I_{OS}	$T_A = +25^\circ C$		0.5	30		0.5	30		0.5	30	pA
		C: $0^\circ C \leq T_A \leq +70^\circ C$		300			300			300		
		M: $-55^\circ C \leq T_A \leq +125^\circ C$		800			800			800		
Input Bias Current	I_{BIAS}	$T_A = +25^\circ C$		1.0	50		1.0	50		1.0	50	pA
		C: $0^\circ C \leq T_A \leq +70^\circ C$		500			500			500		
		M: $-55^\circ C \leq T_A \leq +125^\circ C$		4000			4000			4000		

Electrical Characteristics (Triple/Quad) (continued)

(V_{SUPP} = ±5.0V, T_A = +25°C, unless otherwise noted.)

PARAMETER	SYMBOL	CONDITIONS	ICL76XXB			ICL76XXC			ICL76XXE			UNITS	
			MIN	TYP	MAX	MIN	TYP	MAX	MIN	TYP	MAX		
Common-Mode Voltage Range	V _{CMR}	I _Q = 10µA (Note 7)	+4.4			+4.4			+4.4			V	
			-4.0			-4.0			-4.0				
		I _Q = 100µA (Note 9)	+4.2			+4.2			+4.2				
			-4.0			-4.0			-4.0				
		I _Q = 1mA (Note 8)	+3.7			+3.7			+3.7				
			-3.7			-3.7			-3.7				
Output Voltage Swing	V _{OUT}	I _Q = 10µA, R _L = 1MΩ (Note 7)	T _A = +25°C	±4.9			Q4.9			Q4.9			V
			C: 0°C ≤ T _A ≤ +70°C	±4.8			±4.8			±4.8			
			M: -55°C ≤ T _A ≤ +125°C	±4.7			±4.7			±4.7			
		I _Q = 100µA, R _L = 100kΩ (Note 9)	T _A = +25°C	±4.9			±4.9			±4.9			
			C: 0°C ≤ T _A ≤ +70°C	±4.8			±4.8			±4.8			
			M: -55°C ≤ T _A ≤ +125°C	±4.5			±4.5			±4.5			
		I _Q = 1mA, R _L = 10kΩ (Note 8)	T _A = +25°C	±4.5			±4.5			±4.5			
			C: 0°C ≤ T _A ≤ +70°C	±4.3			±4.3			±4.3			
			M: -55°C ≤ T _A ≤ +125°C	±4.0			±4.0			±4.0			

Electrical Characteristics (Triple/Quad) (continued)

($V_{SUPP} = \pm 5.0V$, $T_A = +25^\circ C$, unless otherwise noted.)

PARAMETER	SYMBOL	CONDITIONS	ICL76XXB			ICL76XXC			ICL76XXE			UNITS
			MIN	TYP	MAX	MIN	TYP	MAX	MIN	TYP	MAX	
Large-Signal Voltage Gain	A_{VOL}	$V_O = \pm 4.0V$, $R_L = 1M\Omega$, $I_Q = 10\mu A$ (Note 7)	$T_A = +25^\circ C$	86	104		80	104		80	104	dB
			C: $0^\circ C \leq T_A \leq +70^\circ C$	80			75			75		
			M: $-55^\circ C \leq T_A \leq +125^\circ C$	74			68			68		
		$V_O = \pm 4.0V$, $R_L = 100k\Omega$, $I_Q = 100\mu A$	$T_A = +25^\circ C$	86	102		80	102		80	102	
			C: $0^\circ C \leq T_A \leq +70^\circ C$	80			75			75		
			M: $-55^\circ C \leq T_A \leq +125^\circ C$	74			68			68		
		$V_O = \pm 4.0V$, $R_L = 10k\Omega$ (Note 8), $I_Q = 1mA$ (Note 7)	$T_A = +25^\circ C$	86	98		80	98		80	98	
			C: $0^\circ C \leq T_A \leq +70^\circ C$	80			75			75		
			M: $-55^\circ C \leq T_A \leq +125^\circ C$	74			68			68		

Electrical Characteristics (Triple/Quad) (continued)

($V_{SUPP} = \pm 5.0V$, $T_A = +25^\circ C$, unless otherwise noted.)

PARAMETER	SYMBOL	CONDITIONS	ICL76XXB			ICL76XXC			ICL76XXE			UNITS	
			MIN	TYP	MAX	MIN	TYP	MAX	MIN	TYP	MAX		
Unity-Gain Bandwidth	G_{BW}	$I_Q = 10\mu A$ (Note 7)	0.044			0.044			0.044			MHz	
		$I_Q = 100\mu A$ (Note 9)	0.48			0.48			0.48				
		$I_Q = 1mA$ (Note 8)	1.4			1.4			1.4				
Input Resistance	R_{IN}		10^{12}			10^{12}			10^{12}			Ω	
Common-Mode Rejection Ratio	CMRR	$R_S \leq 100k\Omega$, $I_Q = 10\mu A$ (Note 7)	76	96		70	96		70	96		dB	
		$R_S \leq 100k\Omega$, $I_Q = 100\mu A$	76	91		70	91		70	91			
		$R_S \leq 100k\Omega$, $I_Q = 1mA$ (Note 8)	66	87		60	87		60	87			
Power-Supply Rejection Ratio	PSRR	$R_S \leq 100k\Omega$, $I_Q = 10\mu A$ (Note 7)	80	94		80	94		80	94		dB	
		$R_S \leq 100k\Omega$, $I_Q = 100\mu A$	80	86		80	86		80	86			
		$R_S \leq 100k\Omega$, $I_Q = 1mA$ (Note 8)	70	77		70	77		70	77			
Input-Referred Noise Voltage	e_n	$R_S = 100\Omega$, $f = 1kHz$	100			100			100			nV/\sqrt{Hz}	
Input-Referred Noise Current	i_n	$R_S = 100\Omega$, $f = 1kHz$	0.01			0.01			0.01			pA/\sqrt{Hz}	
Supply Current (Per Amplifier)	I_{SUPP}	No signal, no load	$I_Q = 10\mu A$ (Note 7)	0.01	0.022		0.01	0.022		0.01	0.022	mA	
		$I_Q = 100\mu A$	0.1	0.25		0.1	0.25		0.1	0.25			
		$I_Q = 1mA$ (Note 8)	1.0	2.5		1.0	2.5		1.0	2.5			
Channel Separation	V_{O1} / V_{O2}	$A_{VOL} = 100$	120			120			120			dB	
Slew Rate (Note 10)	SR	$A_{VOL} = 1$, $C_L = 100pF$, $V_{IN} = 8V_{P-P}$	$I_Q = 10\mu A$ (Note 7), $R_L = 1M\Omega$	0.016			0.016			0.016			V/ μs
			$I_Q = 100\mu A$, $R_L = 100k\Omega$	0.16			0.16			0.16			
			$I_Q = 1mA$ (Note 7), $R_L = 10k\Omega$	1.6			1.6			1.6			

Electrical Characteristics (Triple/Quad) (continued)

($V_{SUPP} = \pm 5.0V$, $T_A = +25^\circ C$, unless otherwise noted.)

PARAMETER	SYMBOL	CONDITIONS	ICL76XXB			ICL76XXC			ICL76XXE			UNITS	
			MIN	TYP	MAX	MIN	TYP	MAX	MIN	TYP	MAX		
Rise Time (Note 10)	t_r	$V_{IN} = 50mV$, $C_L = 100pF$	$I_Q = 10\mu A$ (Note 7), $R_L = 1M\Omega$	20			20			20			μs
			$I_Q = 100\mu A$, $R_L = 100k\Omega$	2			2			2			
			$I_Q = 1mA$ (Note 8), $R_L = 10k\Omega$	0.9			0.9			0.9			
Overshoot Factor (Note 10)		$V_{IN} = 50mV$, $C_L = 100pF$	$I_Q = 10\mu A$ (Note 7), $R_L = 1M\Omega$	5			5			5			%
			$I_Q = 100\mu A$, $R_L = 100k\Omega$	10			10			10			
			$I_Q = 1mA$ (Note 8), $R_L = 10k\Omega$	40			40			40			

Note 7: Does not apply to ICL7641.

Note 8: Does not apply to ICL7642.

Note 9: ICL7631/ICL7632 only.

Note 10: Does not apply to ICL7632.

Typical Operating Characteristics

($T_A = +25^\circ C$, unless otherwise noted.)

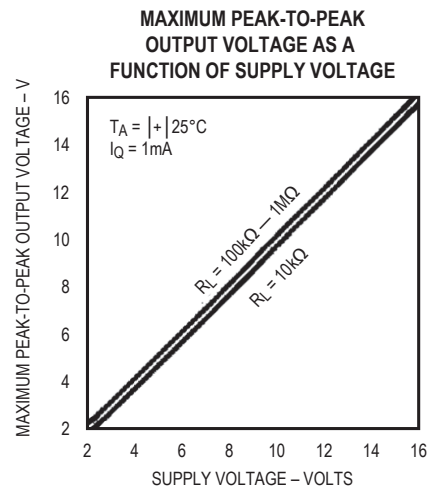
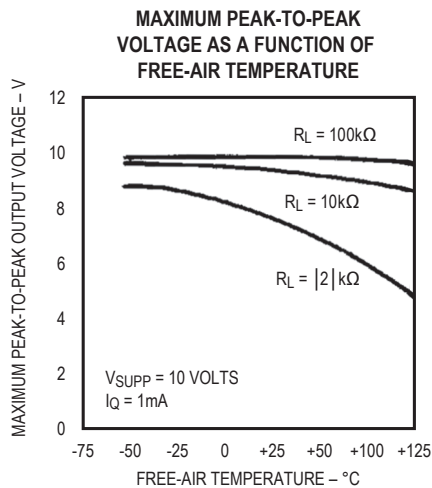

Typical Operating Characteristics (continued)

($T_A = +25^\circ\text{C}$, unless otherwise noted.)

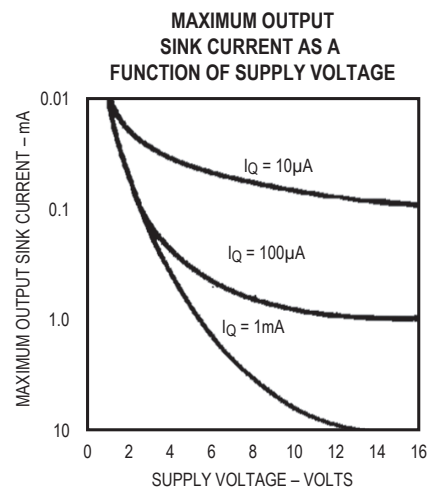
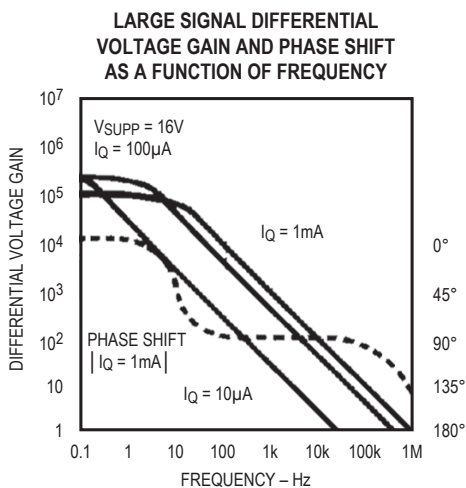
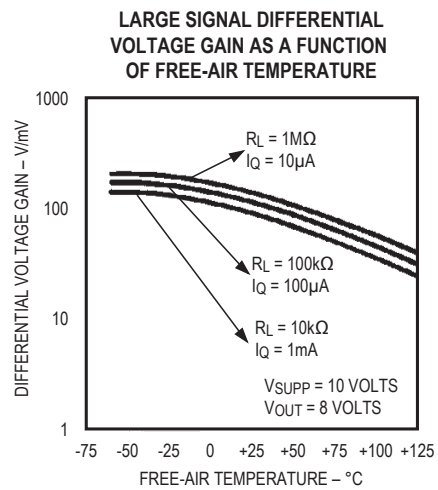
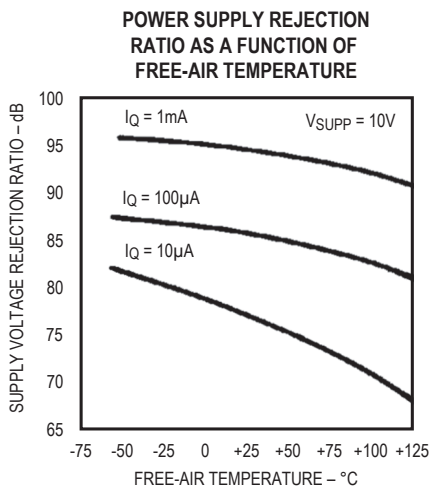
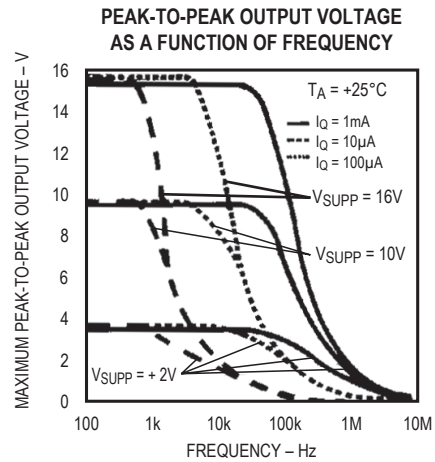
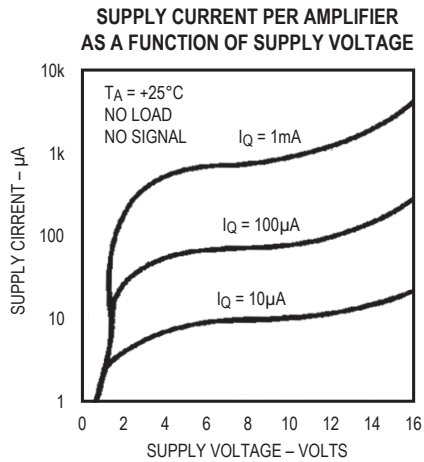

Typical Operating Characteristics (continued)

($T_A = +25^\circ\text{C}$, unless otherwise noted.)

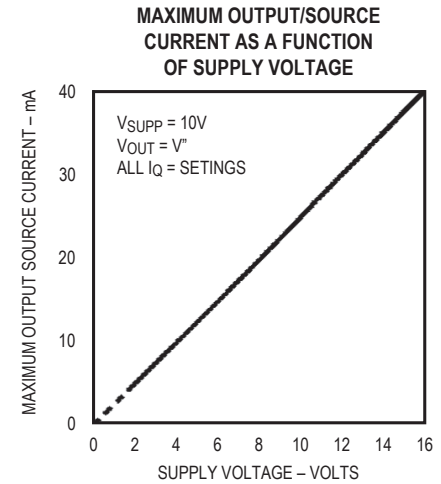
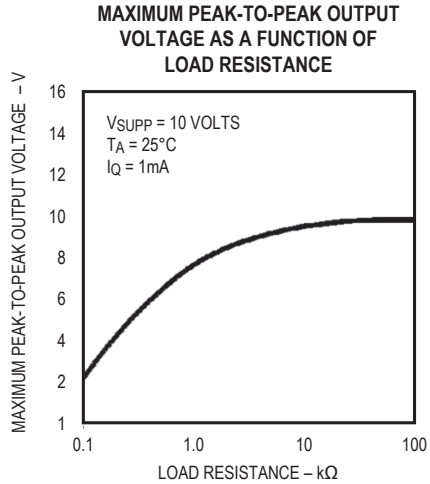
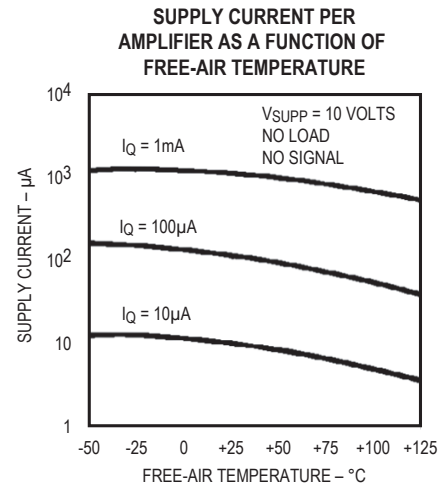
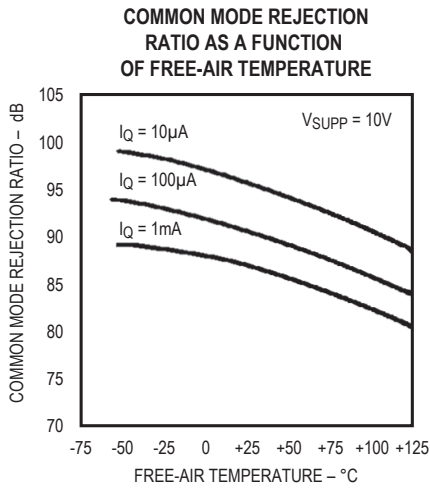
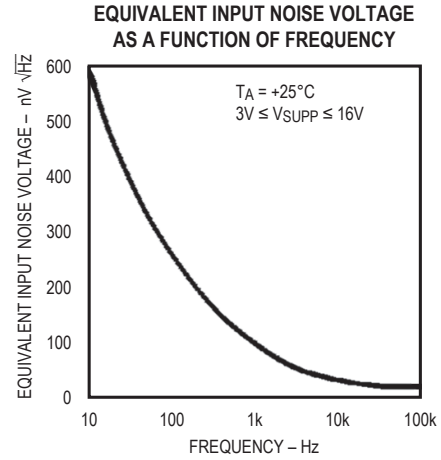
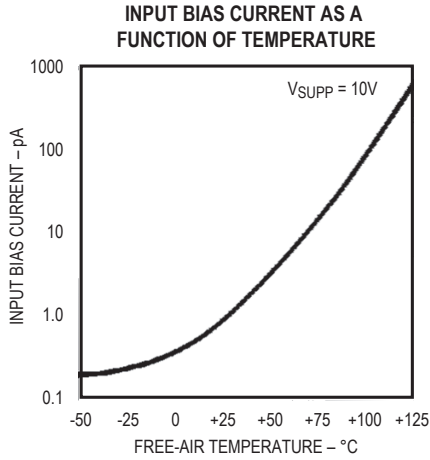

Typical Operating Characteristics (continued)

($T_A = +25^\circ\text{C}$, unless otherwise noted.)

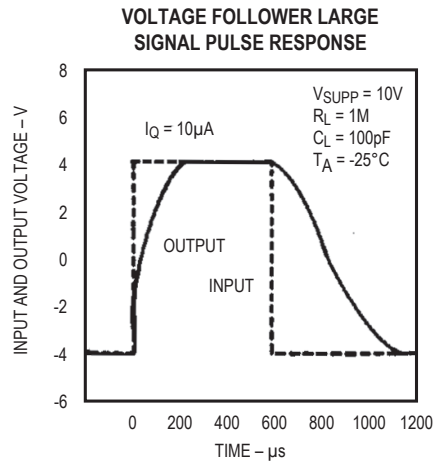
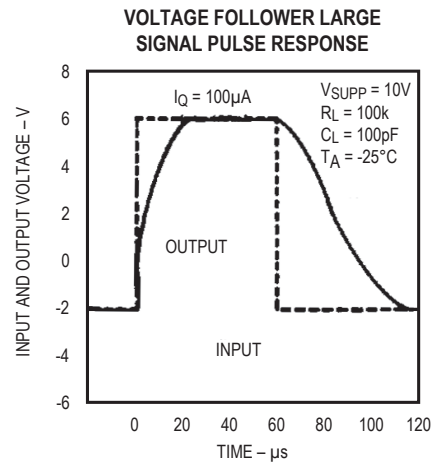
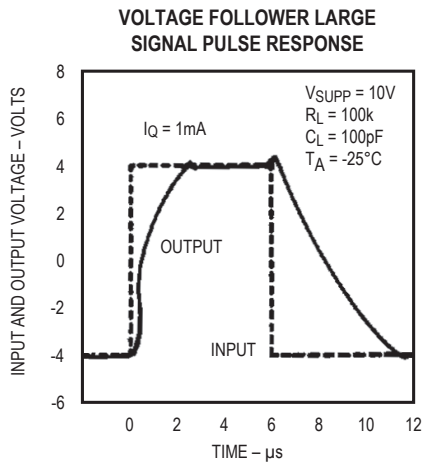

Detailed Description

Quiescent Current Selection

The voltage input to the I_Q pin of the single and triple amplifiers selects a quiescent current (I_Q) of 10 μ A, 100 μ A, or 1000 μ A. The dual and quad amplifiers have fixed quiescent current (I_Q) settings. Unity-gain bandwidth and slew-rate increase with increasing quiescent current, as does output sink current capability. The output source current capability is independent of quiescent current.

The lowest I_Q setting that results in sufficient bandwidth and slew rate should be selected for each specific application.

The I_Q pin of the single and triple amplifiers controls the quiescent current as follows:

$I_Q = 10\mu\text{A}$	I_Q pin to V+
$I_Q = 100\mu\text{A}$	I_Q pin between V- + 0.8V and V+ - 0.8V
$I_Q = 1\text{mA}$	I_Q pin to V

Input Offset Nulling

The input offset can be nulled by connecting a 25k Ω pot between the OFFSET terminals with the wiper connected to V+. At quiescent currents of 1mA and 100 μ A, the nulling range provided is adequate for all V_{OS} selections. However, with higher values of V_{OS} , and an I_Q of 10 μ A, nulling may not be possible.

Frequency Compensation

All of the ICL7611 and ICL7621 series except the ICL7614 are internally compensated for unity-gain operation. The ICL7614 is externally compensated by a capacitor connected between COMP and OUT pins, with 39pF being greater than unity. The compensation capacitor value may be reduced to increase the bandwidth and slew rate. The ICL7132 is not compensated and does not have frequency compensation pins. Use only at gains 20 at I_Q of 1mA; at gains > 10 at I_Q of 100 μ A; at gain > 5 at I_Q of 10 μ A.

Output Loading Considerations

Approximately 70% of the amplifier's quiescent current flows in the output stage. The output swing can approach the supply rails for output loads of 1M Ω , 100k Ω , and 10k Ω , using the output stage in a highly linear Class A mode. Crossover distortion is avoided and the voltage gain is maximized in this mode. The output

stage, however, can also be operated in Class AB, which supplies higher output currents (see the *Typical Operating Characteristics*). The voltage gain decreases and the output transfer characteristic is non-linear during the transition from Class A to Class B operation.

The output stage, with a gain that is directly proportional to load impedance, approximates a transconductance amplifier. Approximately the same open-loop gains are obtained at each of the I_Q settings if corresponding loads of 10k Ω , 100k Ω , and 1M Ω are used.

The maximum output source current is higher than the maximum sink current, and is independent of I_Q .

Like most amplifiers, there are output loads for which the amplifier stability is not guaranteed. In particular, avoid capacitive loads greater than 100pF; and while on the 1mA I_Q setting, avoid loads less than 5k Ω . Since the output stage is a transconductance output, very large (>10 μ F) capacitive loads will create a dominant pole and the output will be stable, even with loads that are less than 5k Ω .

Extended Common-Mode Voltage Range (ICL7612/ICL7616)

A common-mode voltage range that includes both V+ and V- is often desirable, especially in single-supply operation. The ICL7612/ICL7616 extended common-mode range op amps are designed specifically to meet this need. The ICL7612 input common-mode voltage range (CMVR) extends beyond both power-supply rails when operated with at least 3V total supply and an I_Q of 10 μ A or 100 μ A. The ICL7616 CMVR includes the negative supply voltage (or ground when operated with a single supply) at an I_Q of 10 μ A or 100 μ A.

PC Board Layout

Careful PC board layout techniques must be used to take full advantage of the very low bias current of the ICL7611 family. The inputs should be encircled with a low-impedance trace, or guard, that is at the same potential as the inputs. In an inverting amplifier, this is normally ground; in a unity-gain buffer connect the guard to the output. A convenient way of guarding the 8-pin TO-99 version of the ICL7611 is to use a 10-pin circle, with the two extra pads on either side of the input pins to provide space for a guard ring (see Figure 8). Assembled boards should be carefully cleaned, and if a high humidity environment is expected, conformally coated.

Single-Supply Operation

The ICL7611 family will operate from a single 2V to 16V power supply. The common-mode voltage range of the standard amplifier types when operated from a single supply is 1.0V to (V+ - 0.6V) at 10µA I_Q. At 100µA I_Q, the CMVR is 1.0V to (V+ - 0.8V), and at 1mA I_Q, the CMVR is 1.3V to (V+ - 1.3V). If this CMVR range is insufficient, use the ICL7612, whose CMVR includes both ground and V+, or the ICL7616, whose CMVR includes ground.

A convenient way to generate a psuedo-ground at V+/2 is to use one op amp of a quad to buffer a V+/2 voltage from a high-impedance resistive divider.

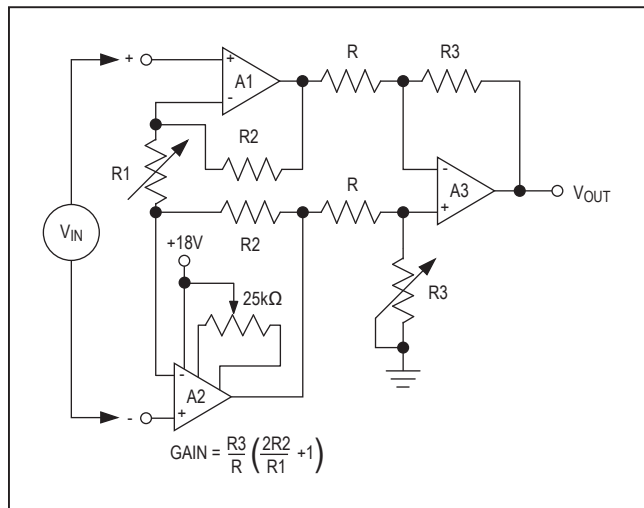

Figure 1. Instrumentation Amplifier—Adjust R3 to improve CMRR. The offset of all three amplifiers is nulled by the offset adjustment of A2.

Low-Voltage Operation

Operation at V_{SUPP} = ±1.0V is only guaranteed at I_Q = 10µA. Output swings to within a few millivolts of the supply rails are achievable for R_L (> or =) 1MΩ. Guaranteed input CMVR is ±0.6V minimum and typically +0.9V to -0.7V at V_{SUPP} = ±1.0V. For applications where greater common-mode range is desirable, see the description of ICL7612 and ICL7616 above.

Applications Information

Note that in no case is I_Q shown. The value of I_Q must be chosen by the designer with regard to frequency response and power dissipation.

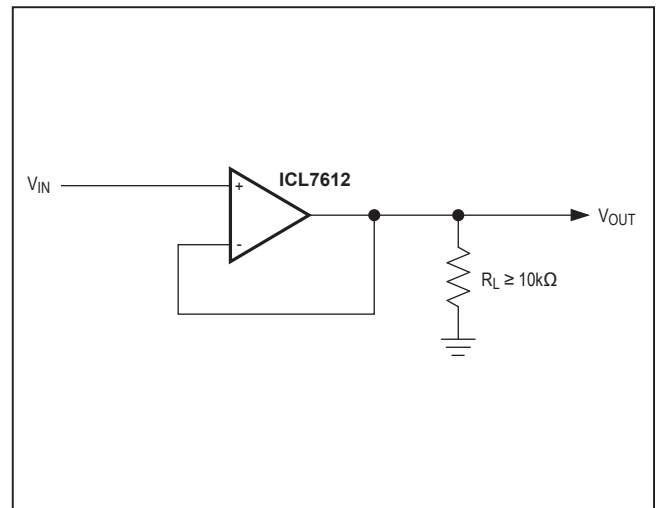

Figure 2. Simple Follower—By using the ICL7612 in these applications, the circuits will follow rail-to-rail inputs

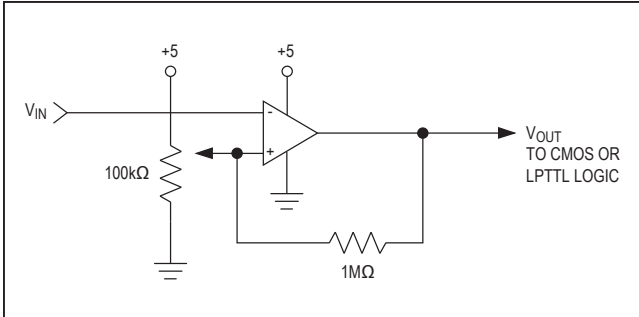

Figure 3. Level Detector—By using the ICL7612 in these applications, the circuits will follow rail-to-rail inputs.

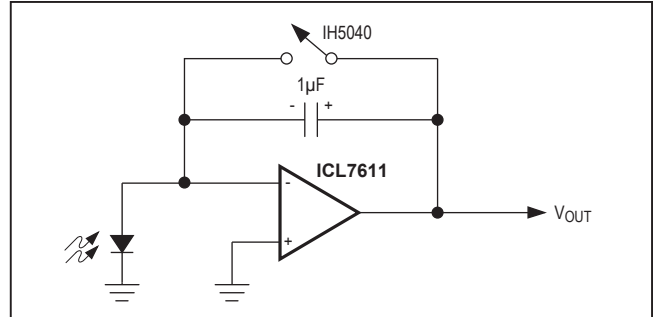

Figure 4. Photocurrent Integrator—Low-leakage currents allow integration times up to several hours.

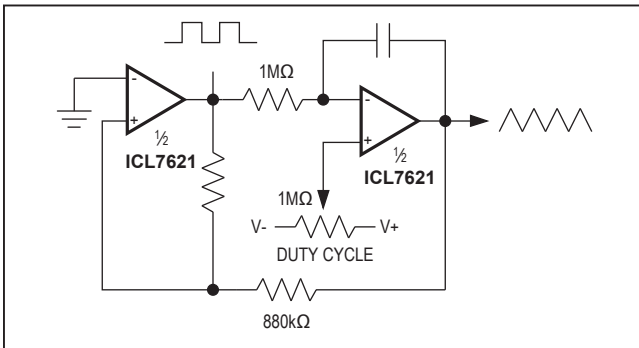

Figure 5. Precise Triangle/Square Wave Generator—The frequency and duty cycle are virtually independent of power supply.

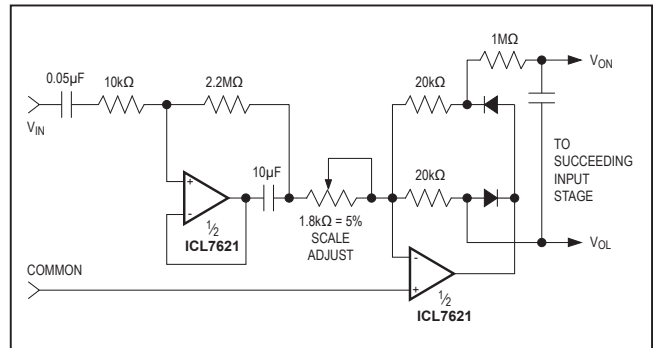

Figure 6. Averaging AC to DC Converter—Recommended for Maxim's ICL7106/ICL7107/ICL7109 A/D Converters.

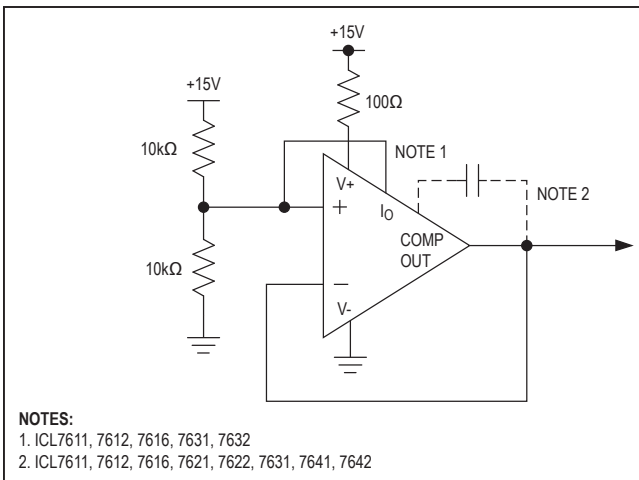

Figure 7. Burn-In and Life Test Circuit

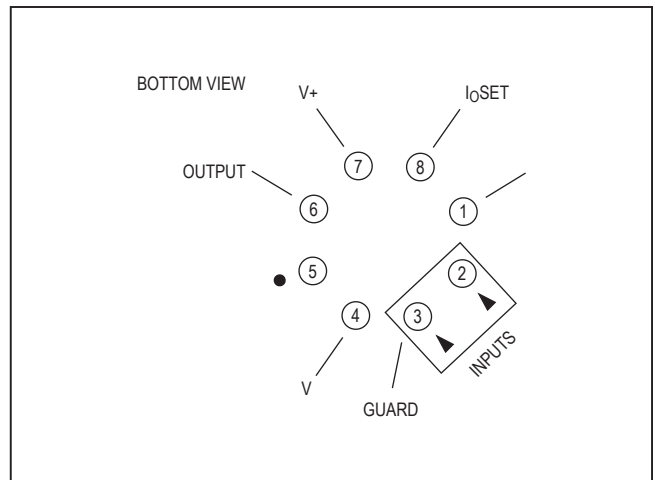

Figure 8. Input Guard for TO-99

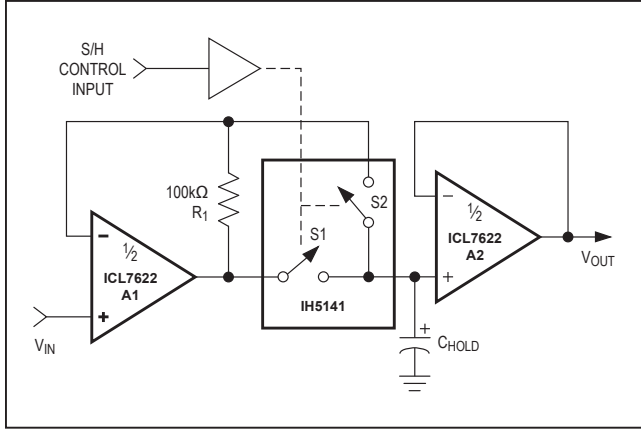

Figure 9. Low Droop Rate Sample and Hold—S2 improves accuracy and acquisition time by including the voltage drop across S1 inside the feedback loop of A1 during the hold phase. R1 closes the feedback loop of A1 during the hold phase. The droop rate is $[I_{BIAS(AZ)} + I_{LEAK(S1)} + I_{LEAK(S2)}]/C_{HOLD}$.

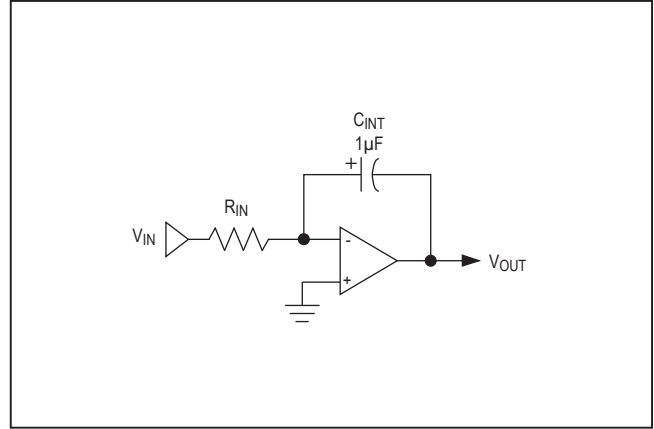

Figure 10. Long-Time Constant Integrator—With $R_{IN} = 1011\Omega$, the time constant of this integrator is 100,000s. Since the input voltage is converted to a current by R_{IN} , the input voltage can far exceed the power-supply range.

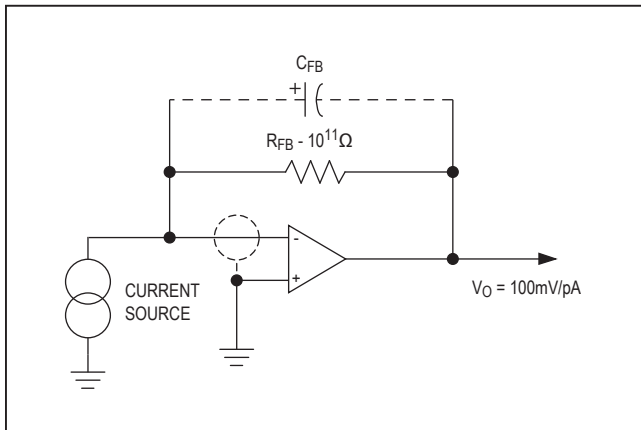

Figure 11. Pico Ammeter—The response time of this circuit is $R_{FB} \times C_{FB}$, where C_{FB} is the stray capacitance between the output and the inverting terminal of the amplifier.

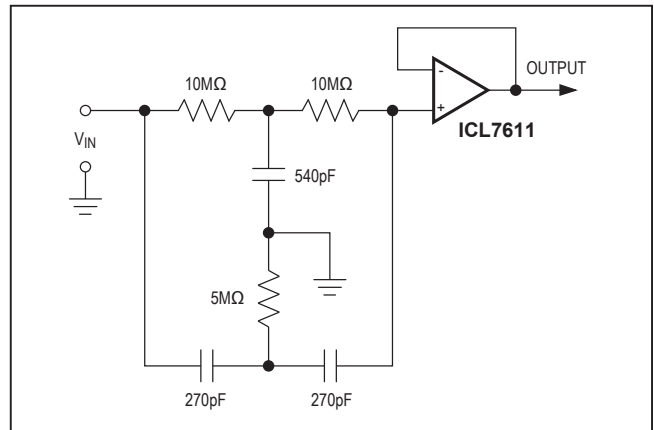
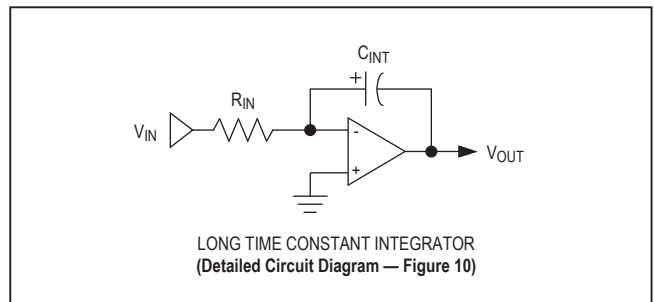
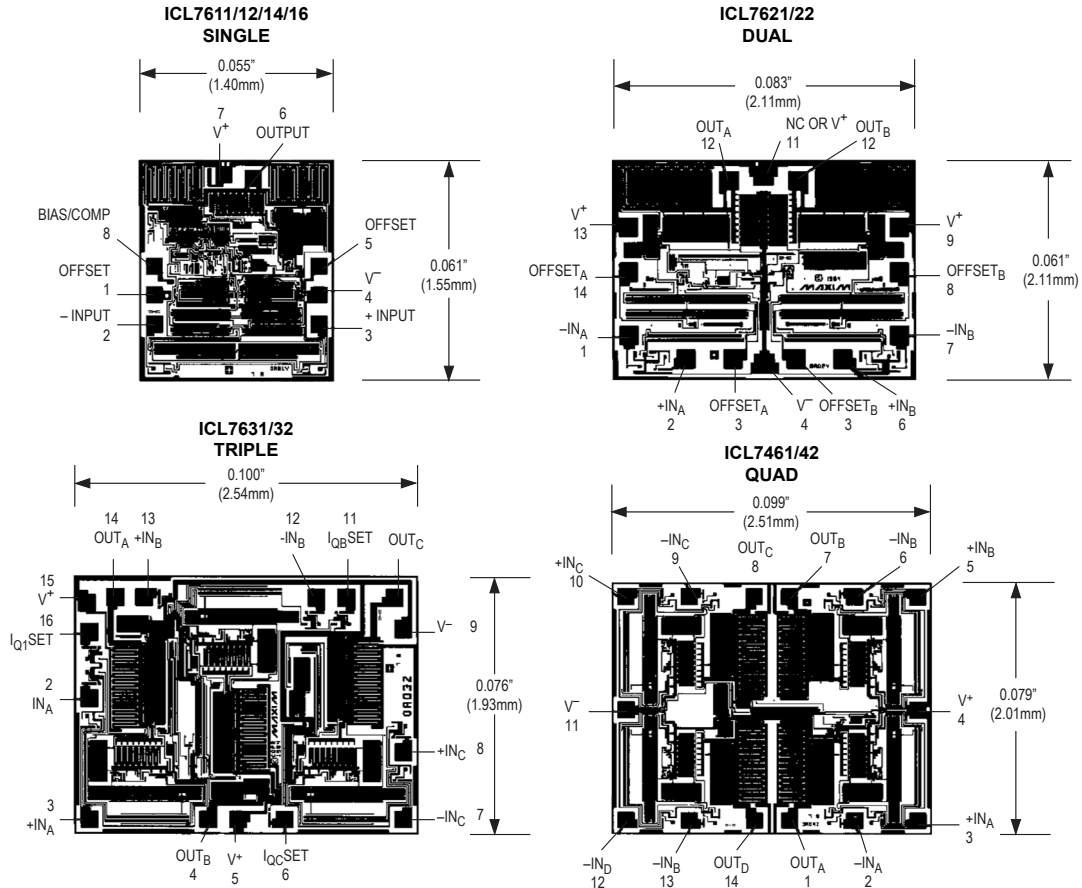

Figure 12. 60Hz Twin “T” Notch Filter—The low 1pA bias current of the ICL7611 allows use of small 540pF and 270pF capacitors, even with a notch frequency of 60Hz. The 60Hz rejection is approximately 40dB.

Typical Operating Circuit



Chip Topographies



Package Information

For the latest package outline information and land patterns (footprints), go to www.maximintegrated.com/packages. Note that a "+", "#", or "-" in the package code indicates RoHS status only. Package drawings may show a different suffix character, but the drawing pertains to the package regardless of RoHS status.

PACKAGE TYPE	PACKAGE CODE	OUTLINE NO.	LAND PATTERN NO.
TO99	T99-8	21-0022	—
8 PDIP	P8-1	21-0043	—
8 SO	S8-2	21-0041	90-0096
8 CDIP	J16-3	21-0045	—
14 PDIP	P14-3	21-0043	—
14 CDIP	J14-3	21-0045	—
16 PDIP	P16-1	21-0043	—
16 SO	S16-1	21-0041	90-0097
16 Wide SO	W16-2	21-0042	90-0107

Revision History

REVISION NUMBER	REVISION DATE	DESCRIPTION	PAGES CHANGED
2	4/08	Removed all part numbers offered in die form from the Ordering Information	2, 11
3	5/10	Corrected letter grades in EC table headings	13–17
4	7/21	Added ICL7621DESA+ part number, temperature range and pin-package to Ordering Information, updated Package Information table.	1, 2, 25, 26

For pricing, delivery, and ordering information, please visit Maxim Integrated's online storefront at <https://www.maximintegrated.com/en/storefront/storefront.html>.

Maxim Integrated cannot assume responsibility for use of any circuitry other than circuitry entirely embodied in a Maxim Integrated product. No circuit patent licenses are implied. Maxim Integrated reserves the right to change the circuitry and specifications without notice at any time. The parametric values (min and max limits) shown in the Electrical Characteristics table are guaranteed. Other parametric values quoted in this data sheet are provided for guidance.

Looking for pricing, stock, or lifecycle information?

Click below to explore more details on WIN SOURCE:

-  [View ICL7631BCSE on WIN SOURCE](#)
-  [Maxim Integrated Information](#)

Optimize Your Supply Chain with WIN SOURCE Solutions

-  Global Sourcing Solution
-  Obsolete Management
-  Cost Control Management
-  Shortage Management
-  Alternative Solution
-  Excess Inventory Management