



**THE DATASHEET OF  
HV528K6-G**



# 16-Channel Serial to Parallel Converter with High Voltage Backplane Driver and Push-Pull Outputs

## Features

- ▶ HVCMOS® technology
- ▶ Output voltage up to +200V
- ▶ Shift register speed 500kHz @  $V_{DD} = 1.7V$
- ▶ 16 high voltage outputs
- ▶ High voltage backplane driver
- ▶ CMOS input levels

## Applications

- ▶ Multiple segment EL display
- ▶ Piezoelectric transducer driver
- ▶ Braille driver

## General Description

The HV528 is a 200V, 16-channel serial to parallel converter. The high voltage outputs and the backplane driver are designed to source and sink  $\pm 1.0mA$ .

The high voltage outputs are controlled by a 16-bit serial shift register, followed by a 16-bit latch. Data is shifted through the shift registers during the low to high clock transition. A data output buffer is provided for cascading multiple devices. Data is transferred to the 16-bit latch when a logic level low is applied to the  $\overline{LE}$  input. Data is stored in the latch when  $\overline{LE}$  is high. Output states are controlled by the data in the latch and by the  $\overline{POL}$  pin.

## Typical Application Circuit

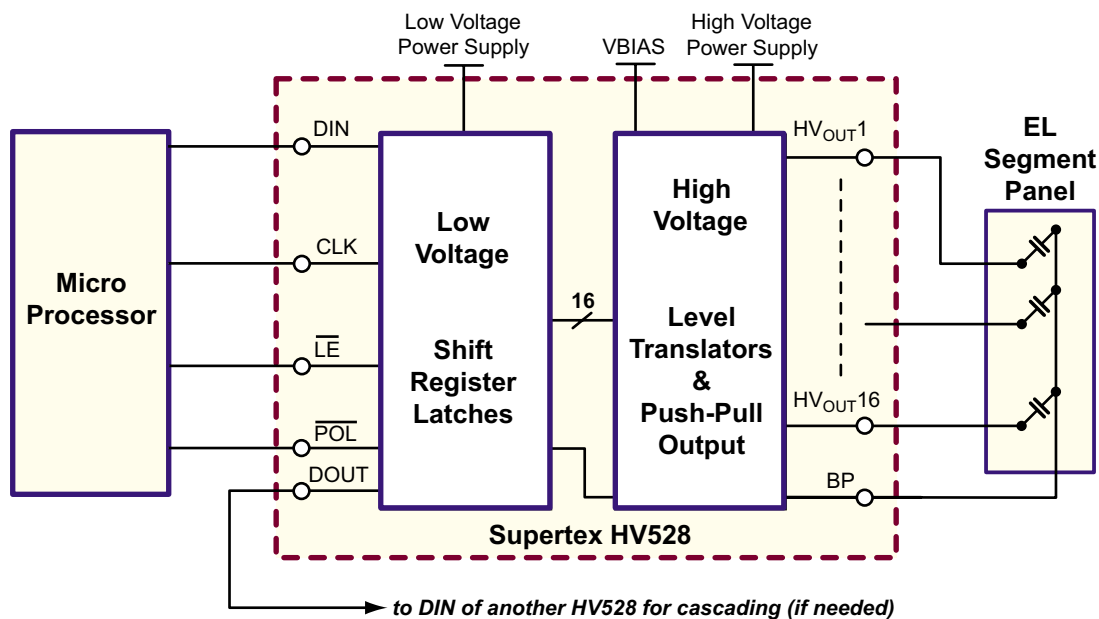

## Ordering Information

Device	Package Option
	<b>32-Lead QFN</b> 5.00x5.00mm body 1.00mm height (max) 0.50mm pitch
HV528	HV528K6-G

-G indicates package is RoHS compliant ('Green')



## Pin Configuration

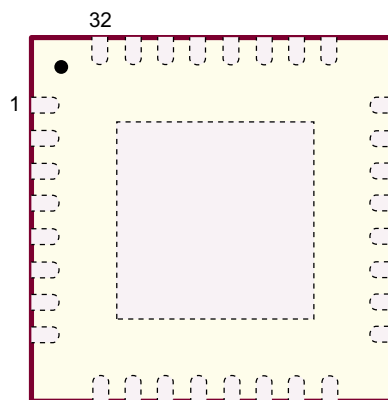

**32-Lead QFN (K6)**  
(top view)

(Bottom side exposed center pad is at  $V_{PP}$  potential)

## Absolute Maximum Ratings

Parameter	Value
Logic supply, $V_{DD}$	-0.5V to 7.0V
High voltage supply, $V_{PP}$	215V
Translator supply voltage, $V_{BIAS}$	-0.5V to 7.0V
Logic input levels	-0.5V to $V_{DD} + 0.5V$
Operating junction temperature	-40°C to +125°C
Storage temperature range	-65°C to +150°C

Absolute Maximum Ratings are those values beyond which damage to the device may occur. Functional operation under these conditions is not implied. Continuous operation of the device at the absolute rating level may affect device reliability. All voltages are referenced to device ground.

## Product Marking

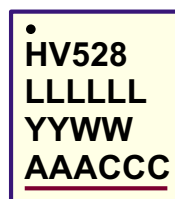

L = Lot Number  
 YY = Year Sealed  
 WW = Week Sealed  
 A = Assembler ID  
 C = Country of Origin  
 — = "Green" Packaging

**32-Lead QFN (K6)**

## Operating Supply Voltages and Conditions

Sym	Parameter	Min	Typ	Max	Units	Conditions
$V_{DD}$	Logic supply voltage	1.7	3.0	5.5	V	---
$V_{BIAS}$	Level translator supply voltage	5.4	-	6.6	V	---
$V_{PP}$	Positive high voltage supply	50	-	200	V	---
$V_{IH}$	High-level input voltage	$0.9V_{DD}$	-	$V_{DD}$	V	---
$V_{IL}$	Low-level input voltage	0	-		V	---
$T_A$	Operating temperature	0	-	+70	°C	---

### Notes:

- External ground noise reduction circuit will be provided by design upon characterization.

### Power-up sequence should be the following\*:

- Apply ground
- Apply  $V_{DD}$
- Set all inputs ( $D_{IN}$ , CLK,  $\overline{LE}$ ,  $\overline{POL}$ ) to a known state
- Apply  $V_{BIAS}$
- Apply  $V_{PP}$

### Power-down sequence should be the reverse of the above

\* This power up sequence requires an external high voltage diode between  $V_{DD}$  and  $V_{PP}$ . Without the diode, power up  $V_{PP}$  to a  $V_{DD}$  level first to bias the silicon substrate. After all other signals are powered, finish raising the  $V_{PP}$  to its final level.

## DC Electrical Characteristics (Over operating supply voltages and temperature, unless otherwise noted)

Sym	Parameter	Min	Typ	Max	Units	Conditions	
$I_{DD}$	$V_{DD}$ supply current	-	-	1.0	mA	$f_{CLK} = 500kHz$	
$I_{DDQ}$	Quiescent $V_{DD}$ supply current	-	-	10	$\mu A$	All logic inputs = $V_{DD}$ or 0V	
$I_{BIAS}$	$V_{BIAS}$ supply current	-	-	100	$\mu A$	All HV <sub>OUTS</sub> switching at 1.0kHz. Peak $I_{BIAS} = 200mA$ with all channels switching	
$I_{BIASQ}$	Quiescent $V_{BIAS}$ current	-	-	10	$\mu A$	No HV <sub>OUT</sub> switching	
$I_{PPQ}$	Quiescent $V_{PP}$ supply current	-	-	100	$\mu A$	$V_{PP} = 200V$ , outputs are static	
$I_{IH}$	High-level logic input current	-	-	10	$\mu A$	$V_{IH} = V_{DD}$	
$I_{IL}$	Low-level logic input current	-	-	-10	$\mu A$	$V_{IL} = 0V$	
$V_{OH}$	High level output	HV <sub>OUT</sub> & BP	$V_{PP} - 30V$	-	-	V	IHV <sub>OUT</sub> = -1.0mA, $50V \leq V_{PP} \leq 100V$
			$V_{PP} - 16V$	-	-	V	IHV <sub>OUT</sub> = -1.0mA, $100V < V_{PP} \leq 200V$
		D <sub>OUT</sub>	$V_{DD} - 1.0V$	-	-	V	ID <sub>OUT</sub> = -1.0mA
$V_{OL}$	Low level output	HV <sub>OUT</sub> & BP	-	-	6.0	V	IHV <sub>OUT</sub> = 1.0mA
		D <sub>OUT</sub>	-	-	1.0	V	ID <sub>OUT</sub> = 1.0mA
$C_{DIN}$	Logic input capacitance	-	-	10	pF	---	
$C_{DOUT}$	Logic output capacitance	-	-	10	pF	---	

## AC Electrical Characteristics (Over operating supply voltages and temperature, unless otherwise noted)

Sym	Parameter	Min	Typ	Max	Units	Conditions
$f_{CLK}$	Clock frequency	0	-	500	kHz	---
$t_C$	Clock high / low pulse width	1.0	-	-	$\mu s$	---
$t_{SU}$	Data setup time before clock rises	50	-	-	ns	---
$t_H$	Data hold time after clock rises	50	-	-	ns	---
$t_{CLE}$	$\overline{LE}$ from CLK setup time	15	-	-	ns	---
$t_{WLE}$	$\overline{LE}$ pulse width	100	-	-	ns	---
$t_{DD}$	Clock negative edge to D <sub>OUT</sub> delay	-	-	150	ns	$C_{LDOUT} = 50pF$ , ( $C_{LDOUT}$ includes $C_{DIN}$ and $C_{DOUT}$ )
$t_{PHV}$	Delay time from inputs for HV <sub>OUT</sub> / BP to start rise/fall	-	-	500	ns	$V_{PP} = 200V$ , $V_{BIAS} = 5.4V$
$t_{OR}$	HV <sub>OUTPUT</sub> / BP rise time	-	-	300	$\mu s$	$C_L = 1500pF$ , $V_{PP} = 200V$
$t_{OF}$	HV <sub>OUTPUT</sub> / BP fall time	-	-	300	$\mu s$	$C_L = 1500pF$ , $V_{BIAS} = 5.4V$ , $V_{PP} = 200V$
$t_{OC}$	Width of $\overline{POL}$ pulses	$t_{PHV} + t_{OR}/t_{OF}$	-	-	$\mu s$	---

**Input and Output Equivalent Circuits**

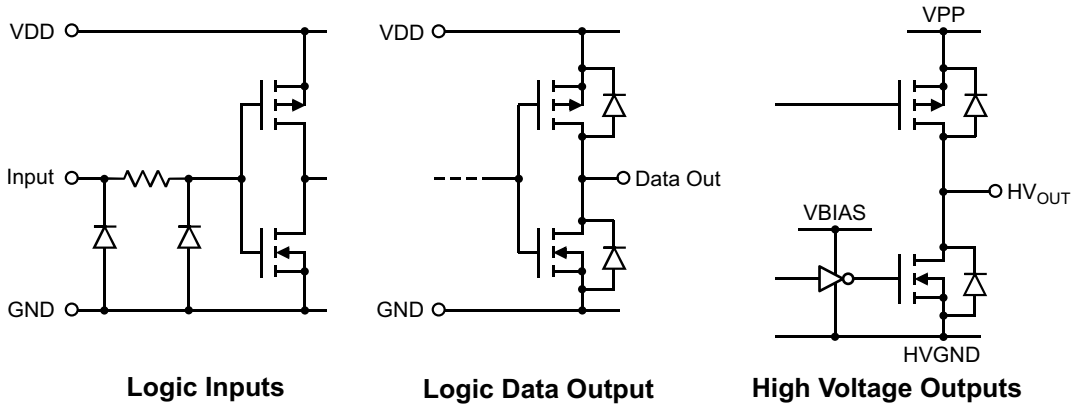

**V<sub>BIAS</sub> SUPPLY**

The V<sub>BIAS</sub> supply operates from 5.4 to 6.6V. It is the gate drive voltage for all of the output N-channel MOSFETs. This allows the output peak current sink to be set by varying the V<sub>BIAS</sub> voltage. A higher V<sub>BIAS</sub> voltage will increase the current sinking capability.

The operating V<sub>DD</sub> range is 1.7 to 5.5V. A plot showing the typical characteristics of I<sub>SINK</sub> vs V<sub>BIAS</sub> is shown below.

**Typical HV<sub>OUT</sub> I<sub>SINK</sub> vs V<sub>BIAS</sub>**

(V<sub>PP</sub> = 200V, C<sub>LOAD</sub> = 1.0nF)

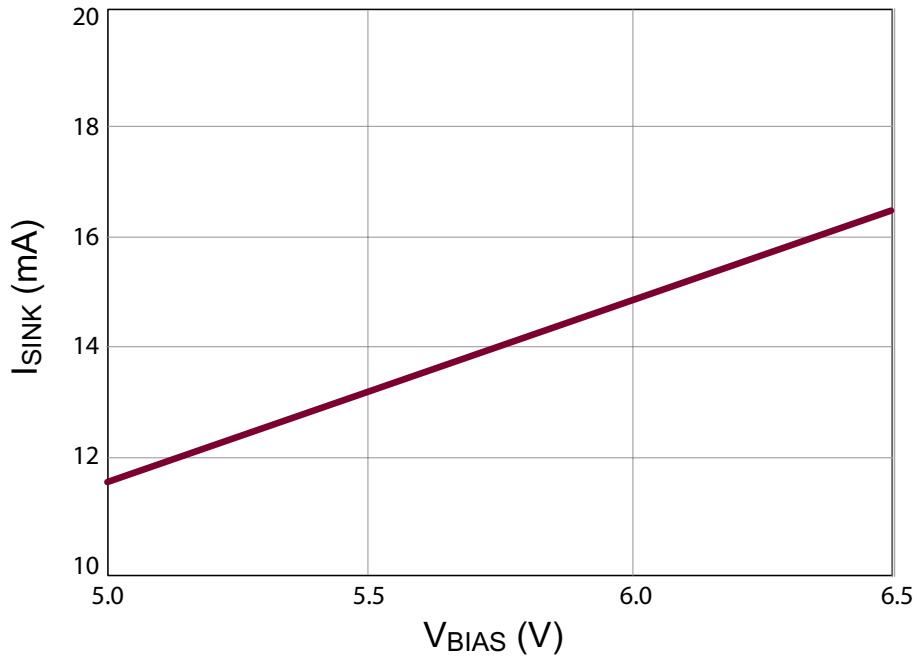

Switching Waveforms

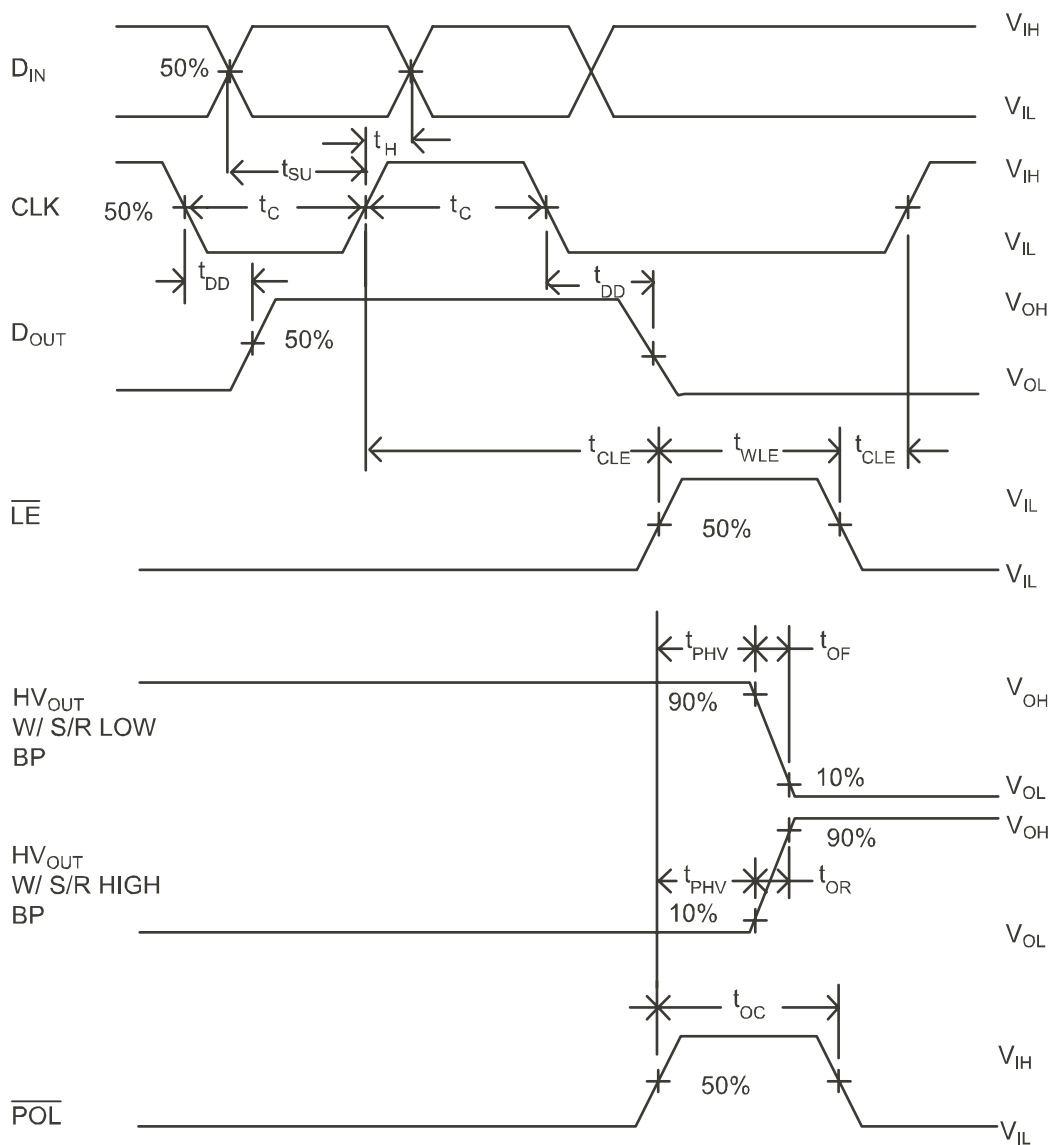

Functional Block Diagram

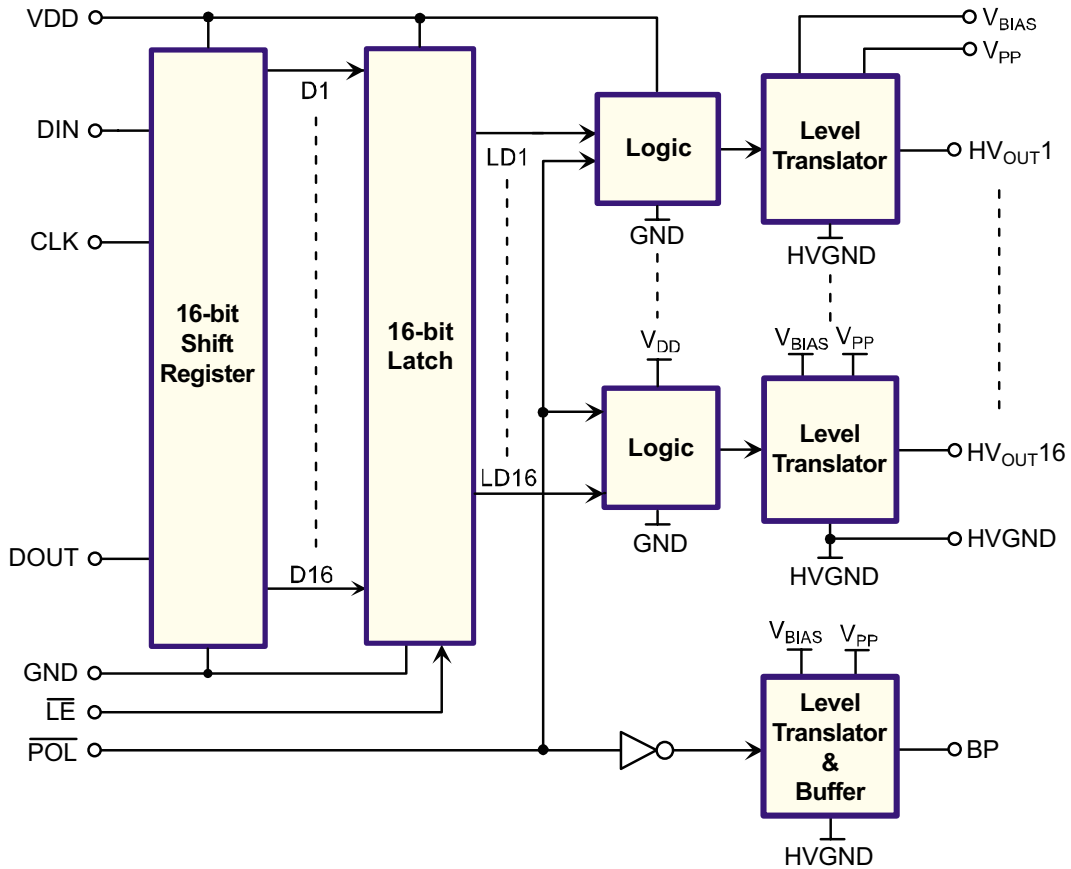

Function Table

Function	Inputs				Outputs			
	DIN	CLK	$\overline{LE}$	$\overline{POL}$	Shift Reg 1 2...16	HV Outputs 1 2...16	BP	DOUT
Load S/R	H OR L	↑	H	X	H or L ●...●	● ●...●	X	●
Transfer data in latch	X	L	L	H	* *...*	* *...*	L	●
	X	L	L	L	* *...*	* *...* (b)	H	●
Store data in latches	X	X	H	H	● ●...●	● ●...●	L	●
	X	X	H	L	● ●...●	● ●...● (b)	H	●
Transparent mode	L	↑	L	H	L ●...●	L ●...●	L	●
	H	↑	L	H	H ●...●	H ●...●	L	●
Invert mode	X	X	H	L	● ●...●	● ●...● (b)	H	X
	X	X	H	H	● ●...●	● ●...●	L	X

Notes:

- H = high level, L = low level, X = irrelevant, ↑ = low-to-high transition
- = dependent on previous stage's state before the last CLK or last  $\overline{LE}$  low
- \* = data at the last CLK ↑
- (b) = bar over all symbols

## Pin Description

Pin #	Function	Description
1	HV <sub>OUT</sub> 12	High voltage push-pull output
2	HV <sub>OUT</sub> 11	
3	HV <sub>OUT</sub> 10	
4	HV <sub>OUT</sub> 9	
5	HV <sub>OUT</sub> 8	
6	HV <sub>OUT</sub> 7	
7	HV <sub>OUT</sub> 6	
8	HV <sub>OUT</sub> 5	
9	HV <sub>OUT</sub> 4	
10	HV <sub>OUT</sub> 3	
11	HV <sub>OUT</sub> 2	
12	HV <sub>OUT</sub> 1	
13	NC	No connect
14	VPP	High voltage supply
15	GND	Logic ground
16	NC	No connect
17	DIN	Data in
18	NC	No connect
19	CLK	Clock input logic
20	VDD	Logic supply voltage
21	$\overline{\text{POL}}$	Polarity bar input logic
22	$\overline{\text{LE}}$	Latch enable bar input logic
23	NC	No connect
24	DOUT	Data out
25	NC	No connect
26	VBIAS	Level translator bias voltage
27	HVGND	High voltage ground
28	BP	High voltage backplane output
29	HV <sub>OUT</sub> 16	High voltage push-pull output
30	HV <sub>OUT</sub> 15	
31	HV <sub>OUT</sub> 14	
32	HV <sub>OUT</sub> 13	
Center Pad		The center pad is at VPP potential. Leave floating or connect to VPP. Do not ground.

# 32-Lead QFN Package Outline (K6)

5.00x5.00mm body, 1.00mm height (max), 0.50mm pitch

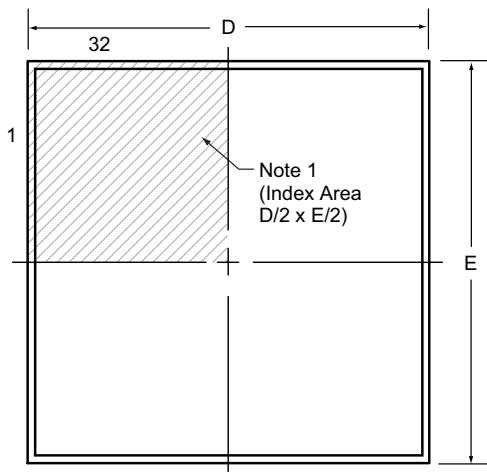

**Top View**

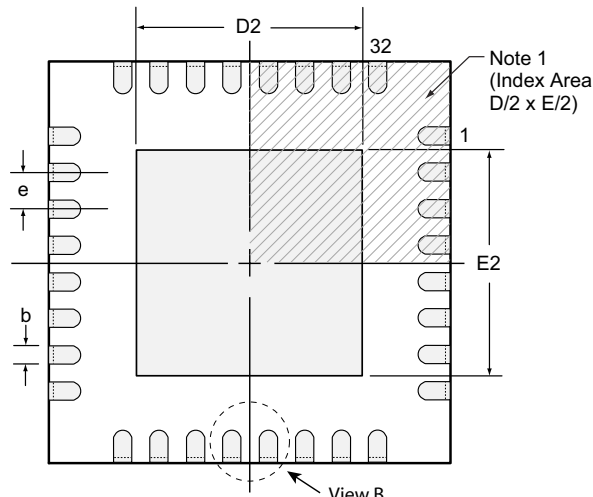

**Bottom View**

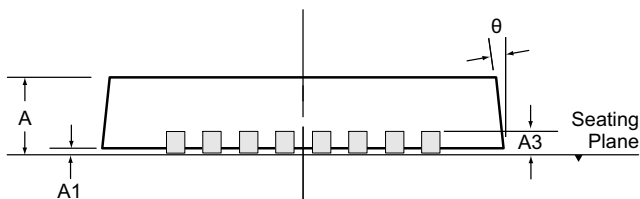

**Side View**

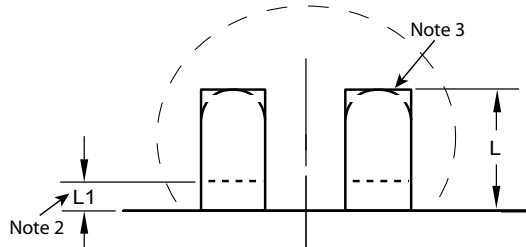

**View B**

**Notes:**

1. A Pin 1 identifier must be located in the index area indicated. The Pin 1 Identifier can be: a molded mark/identifier; an embedded metal marker; or a printed indicator.
2. Depending on the method of manufacturing, a maximum of 0.15mm pullback (L1) may be present.
3. The inner tip of the lead may be either rounded or square.

Symbol		A	A1	A3	b	D	D2	E	E2	e	L	L1	θ
Dimension (mm)	MIN	0.80	0.00	0.20 REF	0.18	4.85*	1.05	4.85*	1.05	0.50 BSC	0.30 <sup>†</sup>	0.00	0°
	NOM	0.90	0.02		0.25	5.00	-	5.00	-		0.40 <sup>†</sup>	-	-
	MAX	1.00	0.05		0.30	5.15*	3.55 <sup>†</sup>	5.15*	3.55 <sup>†</sup>		0.50 <sup>†</sup>	0.15	14°

JEDEC Registration MO-220, Variation VHHD-6, Issue K, June 2006.

\* This dimension is not specified in the original JEDEC drawing. The value listed is for reference only.

† This dimension is a non-JEDEC dimension.

**Drawings not to scale.**



**Supertex Doc. #:** DSPD-32QFNK65X5P050, Version B090808.

(The package drawing(s) in this data sheet may not reflect the most current specifications. For the latest package outline information go to <http://www.supertex.com/packaging.html>.)

Supertex inc. does not recommend the use of its products in life support applications, and will not knowingly sell them for use in such applications unless it receives an adequate "product liability indemnification insurance agreement." Supertex inc. does not assume responsibility for use of devices described, and limits its liability to the replacement of the devices determined defective due to workmanship. No responsibility is assumed for possible omissions and inaccuracies. Circuitry and specifications are subject to change without notice. For the latest product specifications refer to the **Supertex inc.** website: <http://www.supertex.com>.

## Looking for pricing, stock, or lifecycle information?

Click below to explore more details on WIN SOURCE:

-  [View HV528K6-G on WIN SOURCE](#)
-  [Microchip Technology](#) Information

## Optimize Your Supply Chain with WIN SOURCE Solutions

-  Global Sourcing Solution
-  Obsolete Management
-  Cost Control Management
-  Shortage Management
-  Alternative Solution
-  Excess Inventory Management