



THE DATASHEET OF HFM105W-W



**SURFACE MOUNT
HIGH EFFICIENCY SILICON RECTIFIER
VOLTAGE RANGE 50 to 1000 Volts CURRENT 1.0 Ampere**

FEATURES

- * Ideal for surface mounted applications
- * Low leakage current
- * Metallurgically bonded construction
- * Mounting position: Any
- * Weight: 0.078 gram

MECHANICAL DATA

- * Epoxy: Device has UL flammability classification 94V-0

MAXIMUM RATINGS AND ELECTRICAL CHARACTERISTICS

Ratings at 25 °C ambient temperature unless otherwise specified.
Single phase, half wave, 60 Hz, resistive or inductive load.
For capacitive load, derate current by 20%.

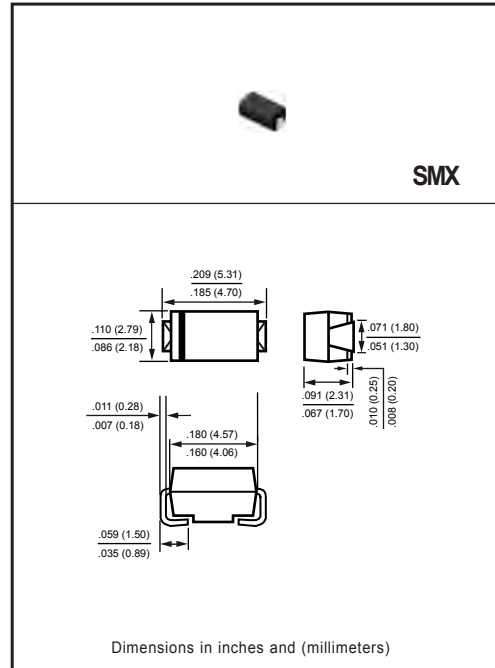

MAXIMUM RATINGS (@ TA=25 °C unless otherwise noted)

RATINGS	SYMBOL	HFM101W	HFM102W	HFM103W	HFM104W	HFM105W	HFM106W	HFM107W	HFM108W	UNITS	
Maximum Recurrent Peak Reverse Voltage	V_{RRM}	50	100	200	300	400	600	800	1000	Volts	
Maximum RMS Voltage	V_{RMS}	35	70	140	210	280	420	490	700	Volts	
Maximum DC Blocking Voltage	V_{DC}	50	100	200	300	400	600	800	1000	Volts	
Maximum Average Forward Rectified Current at $T_A = 50^\circ\text{C}$	I_O	1.0								Amps	
Peak Forward Surge Current 8.3 ms single half sine-wave superimposed on rated load (JEDEC method)	I_{FSM}	30								Amps	
Typical Current Squared Time	I^2t	3.74								A^2S	
Typical Thermal Resistance (Note 1)	$R_{\theta JL}$	27								$^\circ\text{C}/\text{W}$	
Typical Thermal Resistance (Note 1)	$R_{\theta JA}$	75								$^\circ\text{C}/\text{W}$	
Typical Junction Capacitance (Note 2)	C_J	15					12				pF
Operating Temperature Range	T_J	150								$^\circ\text{C}$	
Storage Temperature Range	T_{STG}	-55 to + 150								$^\circ\text{C}$	

ELECTRICAL CHARACTERISTICS (@TA=25 °C unless otherwise noted)

CHARACTERISTICS	SYMBOL	HFM101W	HFM102W	HFM103W	HFM104W	HFM105W	HFM106W	HFM107W	HFM108W	UNITS	
Maximum Instantaneous Forward Voltage at 1.0A DC	V_F	1.0		1.3		1.7				Volts	
Maximum Full Load Reverse Current, Full cycle Average $T_A = 55^\circ\text{C}$	I_R	50								μA	
Maximum Average Reverse Current at Rated DC Blocking Voltage		@ $T_A = 25^\circ\text{C}$	5								μA
	@ $T_A = 125^\circ\text{C}$	100								μA	
Maximum Reverse Recovery Time (Note 4)	t_{rr}	50					75				nSec

- NOTES : 1. Thermal Resistance : Mounted on PCB.
2. Measured at 1 MHz and applied reverse voltage of 4.0 volts.
3. "RoHS compliant"
4. Test Conditions: $I_F = 0.5\text{A}$, $I_R = -1.0\text{A}$, $I_{RR} = -0.25\text{A}$.

RATING AND CHARACTERISTICS CURVES (HFM101W THRU HFM108W)

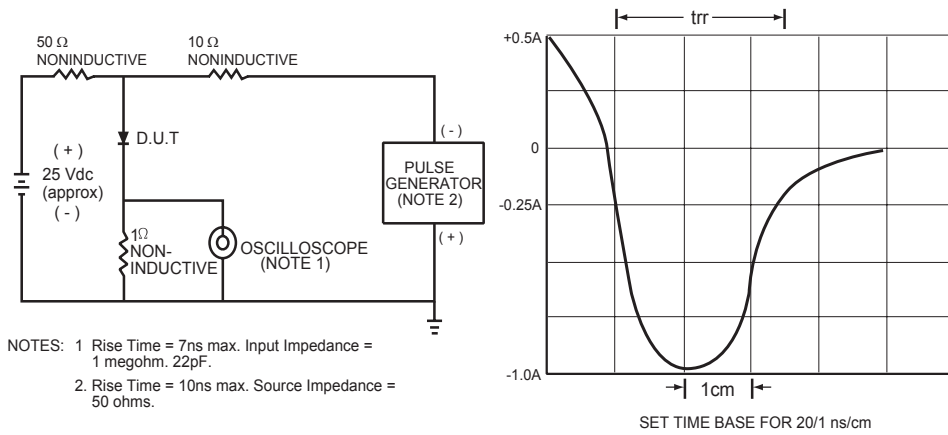

FIG.1 TEST CIRCUIT DIAGRAM AND REVERSE RECOVERY TIME CHARACTERISTIC

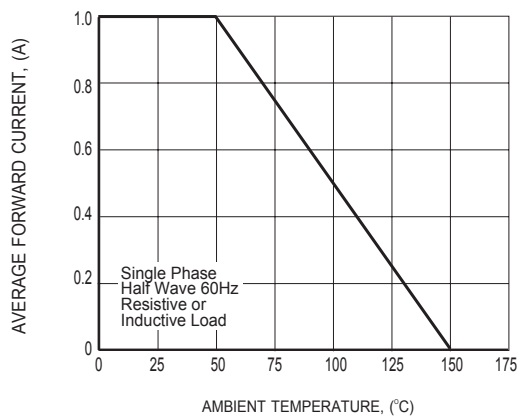

FIG.2 TYPICAL FORWARD CURRENT DERATING CURVE

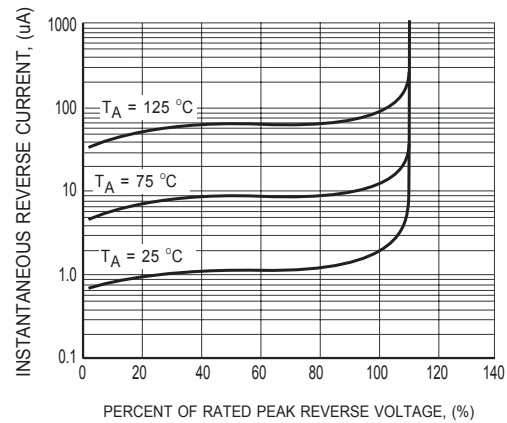

FIG.3 TYPICAL REVERSE CHARACTERISTICS

RATING AND CHARACTERISTICS CURVES (HFM101W THRU HFM108W)

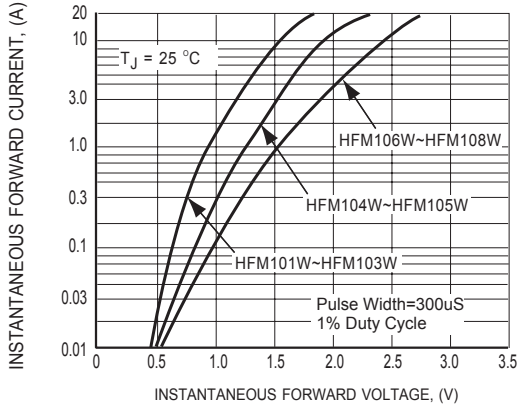

FIG.4 MAXIMUM INSTANTANEOUS FORWARD CHARACTERISTICS

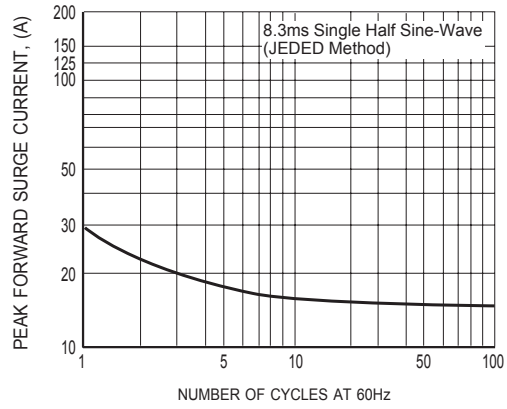

FIG.5 MAXIMUM NON-REPETITIVE FORWARD SURGE CURRENT

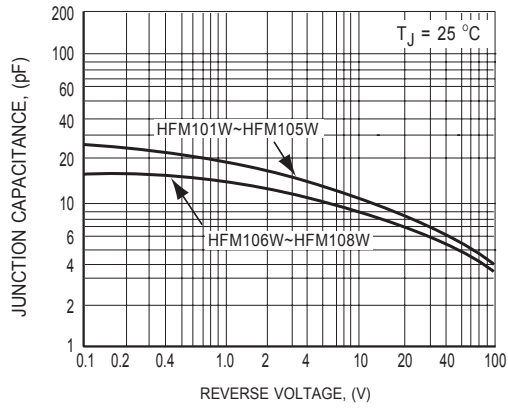
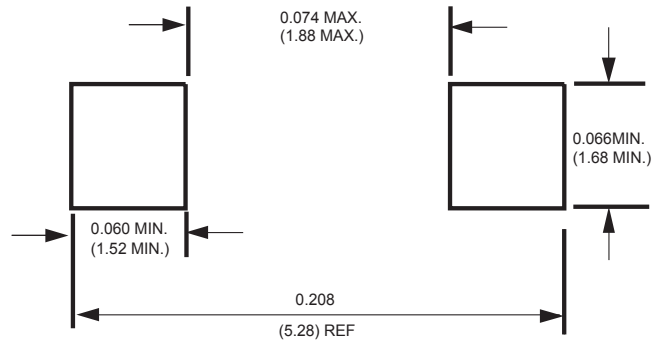

FIG.6 TYPICAL JUNCTION CAPACITANCE

Mounting Pad Layout



Dimensions in inches and (millimeters)

Marking Description

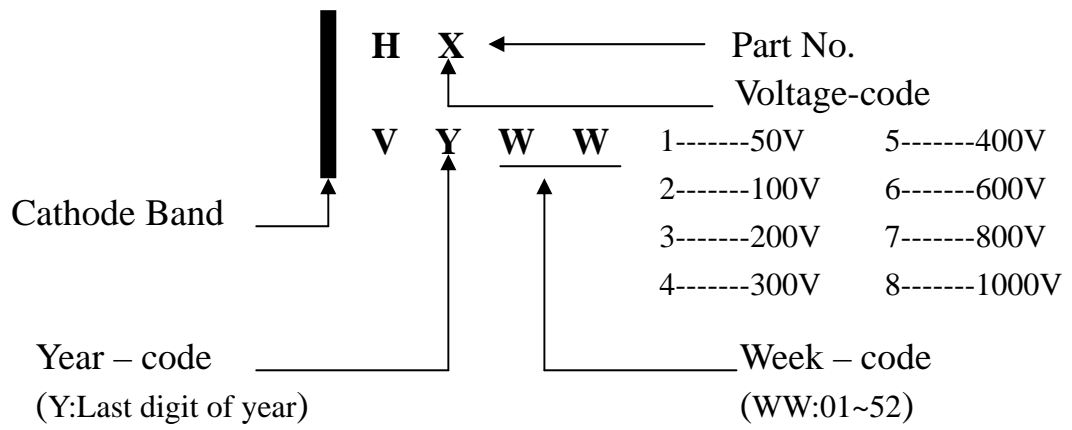

PACKAGING OF DIODE AND BRIDGE RECTIFIERS



REEL PACK

PACKAGE	PACKING CODE	EA PER REEL	EA PER INNER BOX	COMPONENT SPACE (mm)	TAPE SPACE (mm)	REEL DIA (mm)	CARTON SIZE (mm)	EA PER CARTON	GROSS WEIGHT(Kg)
SMX	-W	7,500	15,000	---	---	330	360*355*360	120,000	15.2

PACKAGE	PACKING CODE	EA PER REEL	EA PER INNER BOX	COMPONENT SPACE (mm)	TAPE SPACE (mm)	REEL DIA (mm)	CARTON SIZE (mm)	EA PER CARTON	GROSS WEIGHT(Kg)
SMX	-T	2,000	8,000	---	---	178	390*205*310	64,000	7.8

Looking for pricing, stock, or lifecycle information?

Click below to explore more details on WIN SOURCE:

-  [View HFM105W-W on WIN SOURCE](#)
-  [Rectron USA Information](#)

Optimize Your Supply Chain with WIN SOURCE Solutions

-  Global Sourcing Solution
-  Obsolete Management
-  Cost Control Management
-  Shortage Management
-  Alternative Solution
-  Excess Inventory Management