



THE DATASHEET OF H4001CG





Product Specification for Approval

WE ARE PLEASED IN SUBMITTING OUR SAMPLES WITH SPECIFICATION TO YOU FOR APPROVAL.

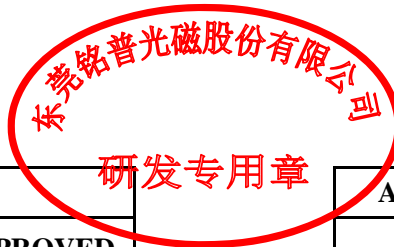
CUSTOMER	:	
DESCRIPTION	:	10/100 BASE-T TRANSFORMER
MNC P/N	:	H4001CG
VERSION	:	A0
CUSTOMER P/N	:	
ISSUED DATE	:	2020/04/27
PHOTO OF PRODUCT	:	
WEIGHT	:	2.58g
MADE IN	:	CHINA



APPROVED BY MNC			APPROVED BY CUSTOMER
PREPARED BY	CHECKED BY	APPROVED BY	SIGNATURE OR STAMP
 研发部 2020-04-27 符晶晶	 研发部 2020-04-27 肖明华	 研发部 2020-04-27 何校民	

1. PLEASE SEND BACK US A COPY OF THE SPECIFICATION WITH YOUR STAMP OR SIGNATURE ONCE THE SAMPLES APPROVED.
2. IT WILL BE DEEMED THE SAMPLES TO BE APPROVED IF NO FEEDBACK.

东莞铭普光磁股份有限公司
 Add: Shipai Town, Dongguan City, Guangdong Province, China

TEL: +86-769-86921000
 FAX: +86-769-81701563

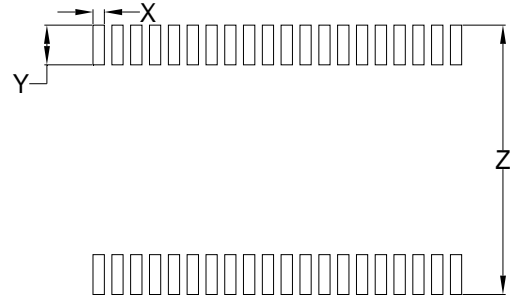
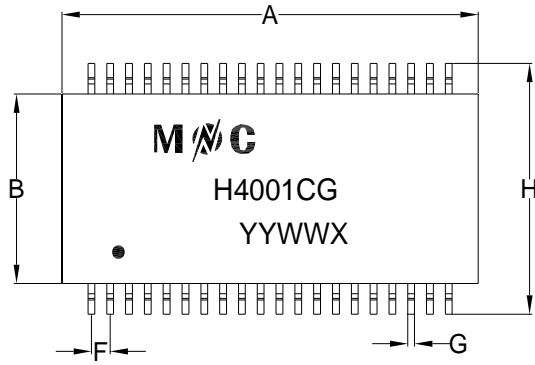
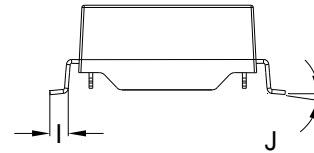
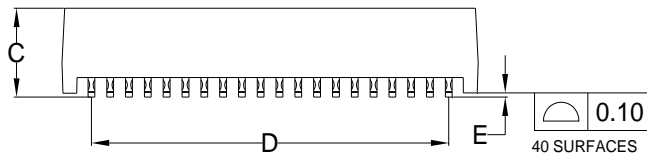
SPECIFICATION
Part No. H4001CG
A. MECHANICAL:

SUGGESTED PAD LAYOUT

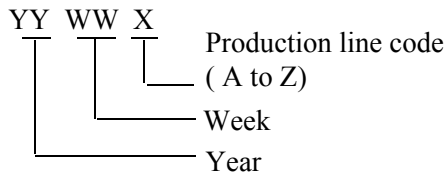
Note: Laser printing marking

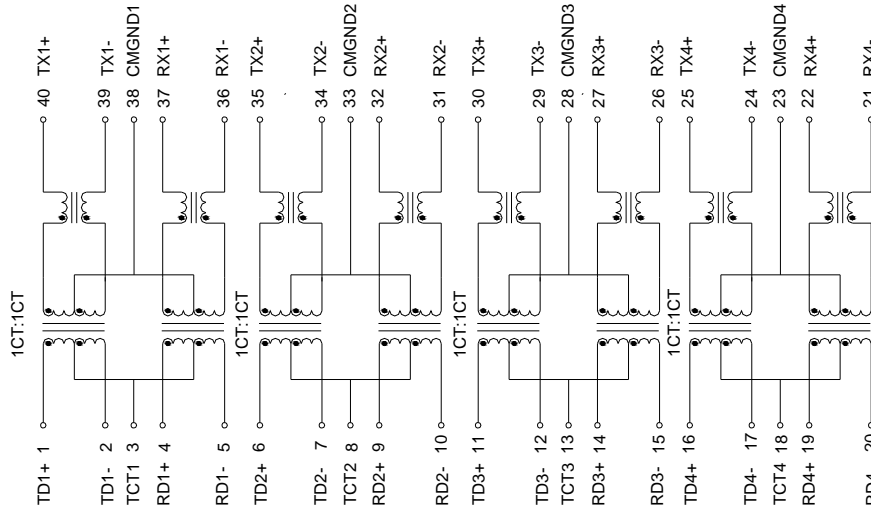

1. UNITS: mm/inch.
2. UNLESS OTHERWISE SPECIFIED ALL TOLERANCES ARE: TYPICAL
3. PIN LENGTH DON'T INCLUDE SOLDER POINT

DIM	MILLIMETERS			INCHES		
	MIN	NOM	MAX	MIN	NOM	MAX
A	27.60	28.10	28.60	1.087	1.106	1.126
B	11.60	12.10	12.60	0.457	0.476	0.496
C	/	/	6.40	/	/	0.252
D	23.63	24.13	24.63	0.930	0.950	0.970
E	0.15	0.30	0.45	0.006	0.012	0.018
F	/	1.27	/	/	0.050	/
G	/	0.46	/	/	0.018	/
H	15.50	16.00	16.50	0.610	0.630	0.650
I	/	0.90	/	/	0.035	/
J	0°	/	8°	0°	/	8°
X	/	0.76	/	/	0.030	/
Y	/	2.54	/	/	0.100	/
Z	/	17.20	/	/	0.677	/

SPECIFICATION
Part No. H4001CG
B. SCHEMATIC :

C. ELECTRICAL SPECIFICATION @25°C

ITEM	SPECIFICATION	TEST CONDITION	TEST EQUIPMENT
INDUCTANCE :	350uH MIN.	100KHz 0.2V 8mA DC Bias	TH2819XB OR EQU.
LEAKAGE INDUCTANCE :	0.50uH MAX.	100KHz 0.2V	TH2819XB OR EQU.
INTERWINDING CAPACITANCE :	50pF TYP.	100KHz 0.2V	TH2819XB OR EQU.
DC RESISTANCE ;	1.2Ω MAX.	AT 25 °C	TOS 8020 OR EQU.
TURNS RATIO :	1CT:1CT(TX)/1CT:1C T(RX)±2%		TH2819XB OR EQU.
POLARITY :	1-40,4-37,6-35,9-32,11- 30,14-27,16-25,19-22 IN-PHASE		
INSERTION LOSS :	-1.1dB MAX.	0.5-100 MHz	E5061A OR EQU.
RETURN LOSS :	-18dB MIN.	0.5-30 MHz	E5061A OR EQU.
	-18+20*log(f/30)dB MIN.	30.1-60MHz	
	-12dB MIN.	60.1-80MHz	
CROSS TALK :	-35dB MIN.	0.5-40 MHz	E5061A OR EQU.
	-33+20*log(f/50)dB MIN.	40.1-100 MHz	
DCMR :	-30dB MIN.	0.5-100 MHz	E5061A OR EQU.
CMRR :	-30dB MIN.	0.5-100 MHz	E5061A OR EQU.
ISOLATION HI-POT :PRI TO SEC	1500VAC	1mA,60S	7152AB OR EQU.
	1650VAC	1mA,6S	
OPERATING TEMPERATURE	0°C TO 70°C		

PACKAGE

Part No. H4001CG

D. PACKING:

a. PACKAGING AS BELOW (ONLY FOR A REFERENCE):

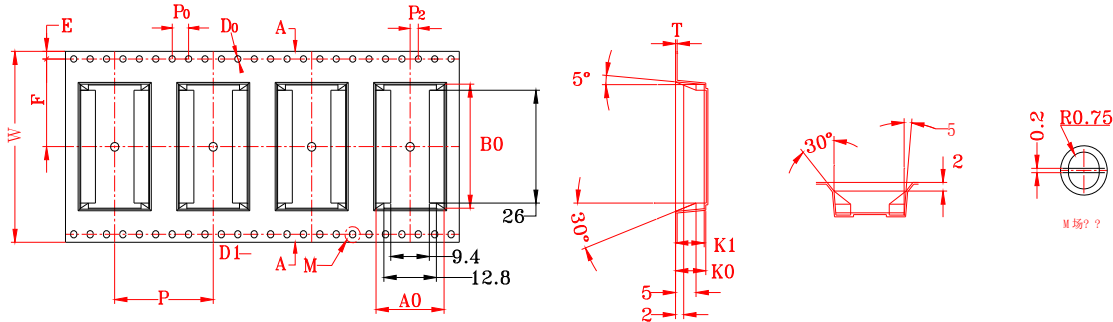

ITEM	W	A ₀	B ₀	K ₀	K ₁	P	F	E	D ₀	D ₁	P ₀	P ₂	T
DIM	44.0 ^{+0.30} _{-0.30}	16.60 ^{+0.10} _{-0.10}	28.40 ^{+0.10} _{-0.10}	7.50 ^{+0.10} _{-0.10}	7.00 ^{+0.10} _{-0.10}	24.00 ^{+0.10} _{-0.10}	20.2 ^{+0.10} _{-0.10}	1.75 ^{+0.10} _{-0.10}	1.50 ^{+0.10} _{-0.10}	2.00 ^{+0.10} _{-0.10}	4.00 ^{+0.10} _{-0.10}	2.00 ^{+0.10} _{-0.10}	0.40 ^{+0.05} _{-0.05}
ALTERNATE													

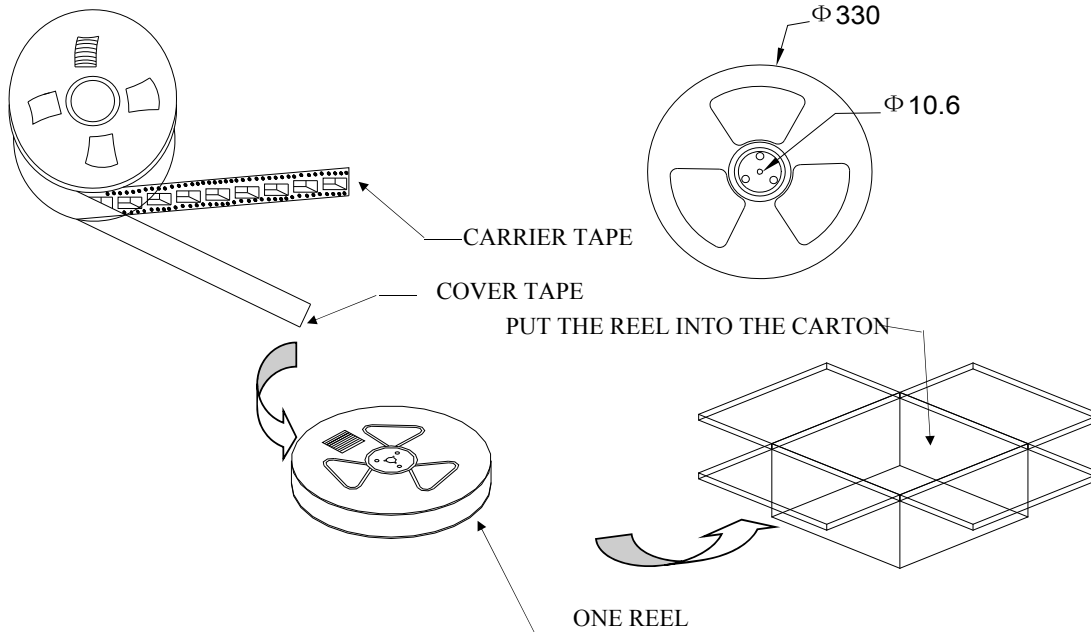

b. Q'TY:

400 PCS PER REEL
5 REELS PER CARTON
2000 PCS PER CARTON

c. LABEL:



REMARK:

ABOVE PACKING IS FOR YOUR REFERENCE ONLY, WHICH MIGHT BE CHANGED WITHOUT NOTICE.

MATERIAL LIST

Part No. H4001CG

E.BOM

MATERIAL LIST					
NO.	ITEM	MATERIAL	RATING	SUPPLIER OF MATERIAL	UL
1	CORE	Mn-Zn	-----	YEAN SHING	N/A
			-----	ZHONGSHAN CRC ELECTRONICS FACTORY	N/A
		Ni-Zn	-----	YEAN SHING	N/A
			-----	ZHONGSHAN CRC ELECTRONICS FACTORY	N/A
2	COPPER WIRE	QPN180	180°C	ZHUHAI SUNTEK WIRE CO.,LTD	E234867
		Polysol 180	180°C	ELEKTRISOLA(MALAYSIA) SDN.BHD.	E258243
3	CASE	WH-9100	V-0	WAH HONG INDUSTRIAL CORP	E150608
4	PIN	C5191	-----	SHENZHEN MINGSCHIN INDUSTRIAL MATERIAL CO.,LTD	N/A

RECOMMENDED REFLOW SOLDERING PROFILE

Part No. H4001CG

a. RECOMMENDED REFLOW SOLDERING PROFILE:

below content is only for your reference

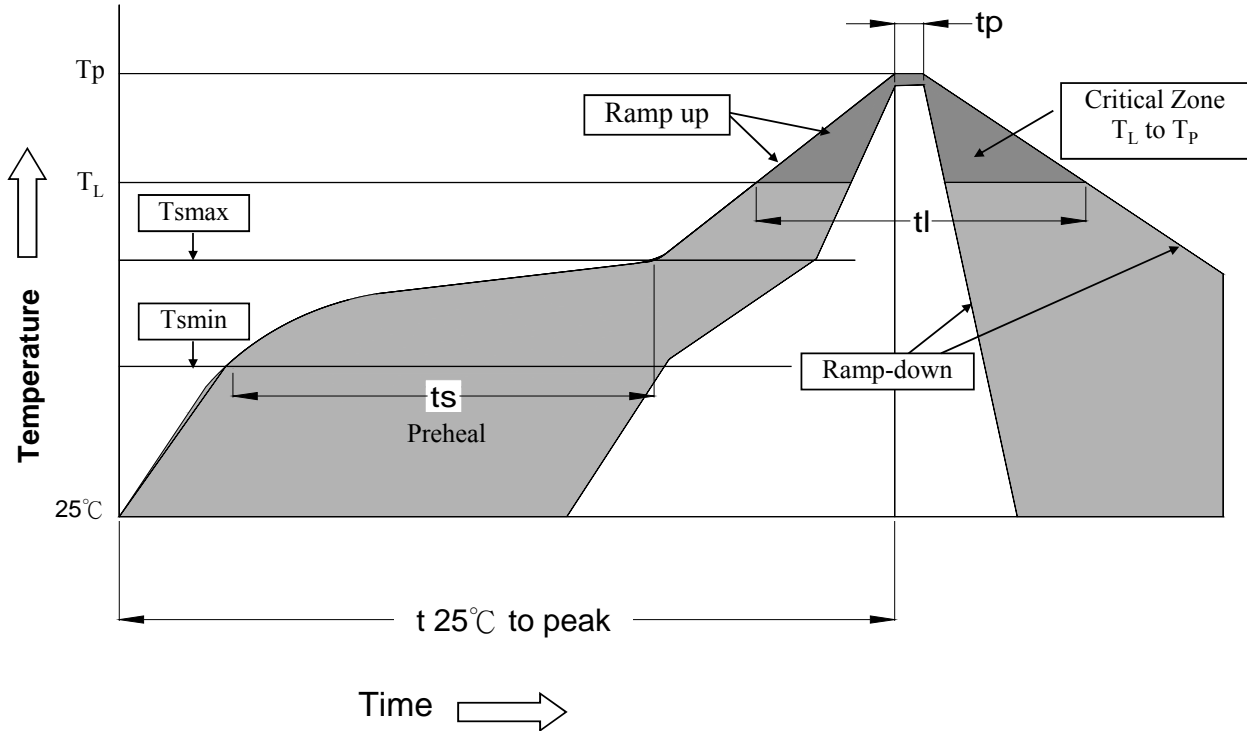

$T_L = 217^\circ\text{C}$

$T_p = 245^\circ\text{C}$

$t_s = 60-180\text{s}$ $T_s \text{ max} = 200^\circ\text{C}$ $T_s \text{ min} = 150^\circ\text{C}$

$t_L = 60-150\text{s}$ $t_p = 20-40\text{s}$ $T_{25^\circ\text{C to peak}} = 8\text{min max}$

Ramp up rate = 3°C/s max Ramp down rate = 6°C/s max

*RoHS Compliant

*Solder Paste SAC 305 Sn 96.5/Ag 3.0/Cu 0.5

*Silkscreen thickness: 0.15mm Min

b. MOISTURE SENSITIVE LEVEL:

b.1. LEVEL: 1

b.2. SHELF LIFE: UNLIMITED

b.3. STORAGE CONDITION: $\leq 30^\circ\text{C}/85\% \text{ RH}$

Looking for pricing, stock, or lifecycle information?

Click below to explore more details on WIN SOURCE:

- [View H4001CG on WIN SOURCE](#)
- [Mentech Technology USA Inc. Information](#)

Optimize Your Supply Chain with WIN SOURCE Solutions

- ✓ Global Sourcing Solution
- ✓ Obsolete Management
- ✓ Cost Control Management
- ✓ Shortage Management
- ✓ Alternative Solution
- ✓ Excess Inventory Management