



THE DATASHEET OF FUSB252UMX



Type-C CC with High Speed Digital (HSD) Port Protection Switch

FUSB252

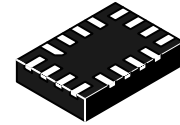

UQFN16 1.8 x 2.6, 0.4P
CASE 523BF

Description

The FUSB252 is an integrated port protection switch for USB Type-C[®] applications. This product will protect HSD+/- and CCx pins when stressed with voltages up to 20 V. Over-Voltage Protection (OVP) at 5.8 V typical will protect the system for Electrical Overstress (EOS) damage. With a fully integrated USB 2.0 switch for HSD+/-, this product can be easily integrated into existing solutions. The HSD switches can pass USB 2.0 signals with bandwidth 1 GHz to maintain signal integrity and eye compliance.

The CC switches have very low RON of 0.3 Ω to minimize signal attenuation. The FUSB252 also provides Dead Battery support per the Type-C specification. Additional features include Under-Voltage Lockout (UVLO) and thermal shutdown.

Features

- Fully Type-C Port Protection
- Supports USB Type-C Specification 1.2
- V_{CC} 0 V – 5.5 V
- 20 V DC Protection on V_{CC}
- 16 V DC Protection on HSD Port
- V_{DD} Operating Range, 2.7 V – 5.5 V
- Current Capability: 1 A
- CC R_{ON}: 0.3 Ω Typical
- HSD R_{ON}: 5 Ω Typical
- Wide -3 db Bandwidth: 1 GHz
- Low Power Operation: I_{CC} = 9 μA Typical
- Dead Battery Support (UFP Support when No Power Applied)
- CC Over-Voltage Protection: Typical = 5.6 V
- This is a Pb-Free Device

Applications

- Smartphones
- Tablets
- Laptops

MARKING DIAGRAM

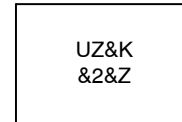

- UZ = Device Code
- &K = 2-Digit Lot Run Traceability Code
- &2 = 2-Digit Date Code
- &Z = Assembly Location

ORDERING INFORMATION

See detailed ordering and shipping information on page 2 of this data sheet.

FUSB252

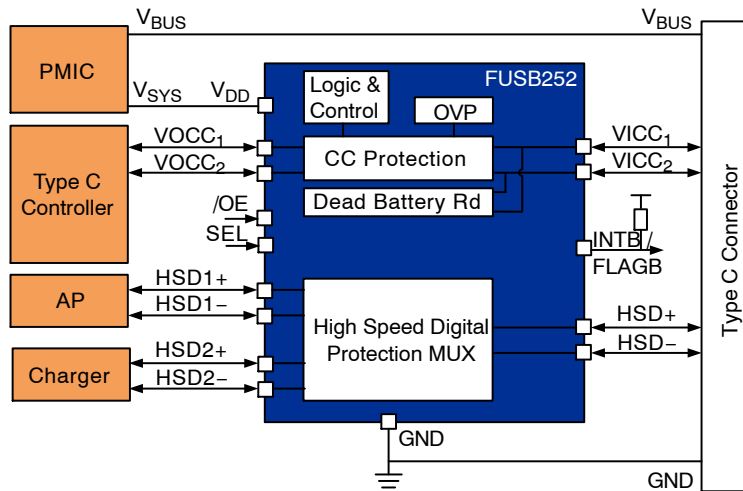

Figure 1. Typical Application

ORDERING INFORMATION

Part Number	Operating Temperature Range	Package	Top Mark	Shipping†
FUSB252UMX	-40 to 85°C	16-Lead Ultrathin Molded Leadless Package (UMLP) 1.8 x 2.6 mm	UZ	5000 / Tape and Reel

†For information on tape and reel specifications, including part orientation and tape sizes, please refer to our Tape and Reel Packaging Specification Brochure, BRD8011/D.

FUSB252

BLOCK DIAGRAM

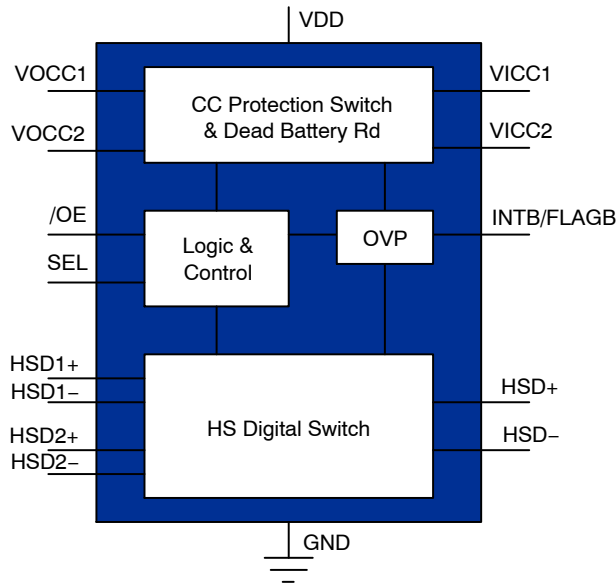

Figure 2. Block Diagram

REFERENCE SCHEMATIC

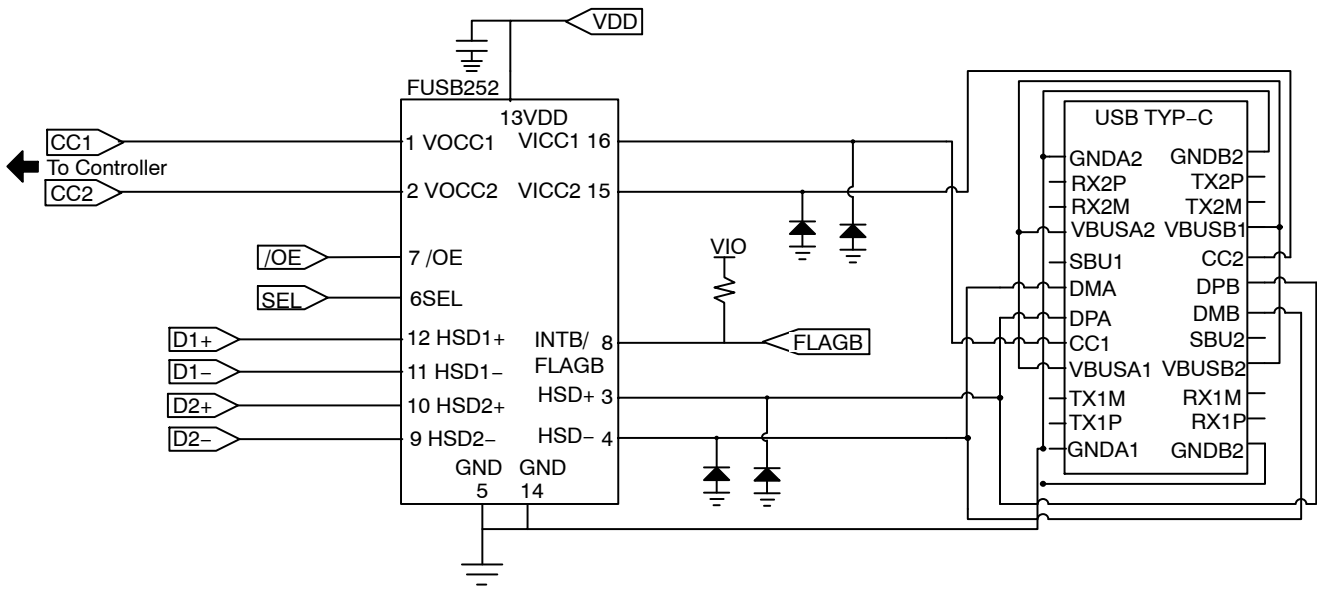

Figure 3. Reference Schematic

FUSB252

PIN CONFIGURATIONS

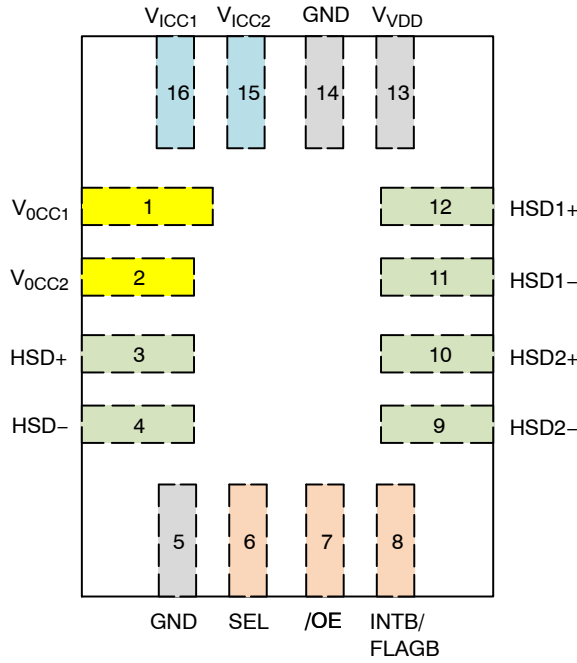

Figure 4. Pin Assignment (Top Through View)

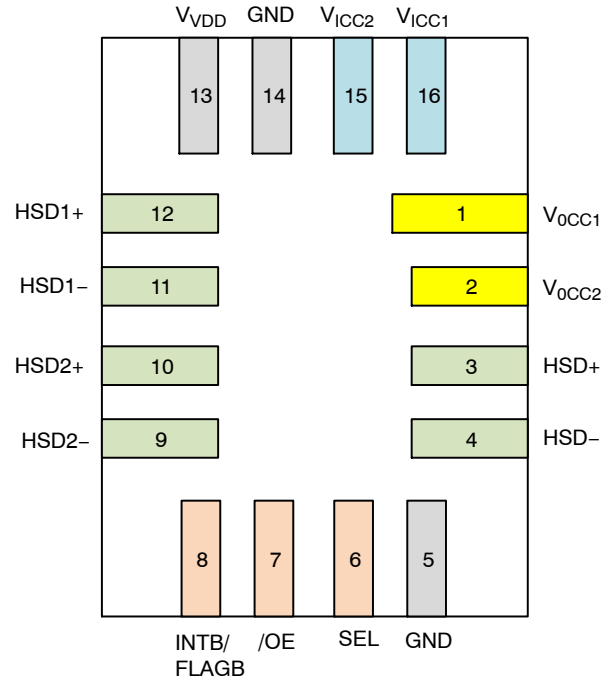

Figure 5. Pin Assignment (Bottom View)

PIN DESCRIPTION

Bump	Name	Type	Description
POWER INTERFACE			
13	VDD	Power	Power
5, 14	GND	Ground	Ground
USB TYPE-C CONNECTOR INTERFACE INPUT			
15, 16	VICC1, 2	Input	Type C CC Interface OVP protection input, Connect to connector
USB TYPE-C CONNECTOR INTERFACE OUTPUT			
1, 2	VOCC1, 2	Output	Type C CC Interface output. Connect to controller
USB HIGH SPEED DATA INTERFACE			
3	HSD+	I/O	Common High Speed Digital / USB Data Bus
4	HSD-	I/O	Common High Speed Digital / USB Data Bus
12	HSD1+	I/O	Multiplexed Source Input 1
11	HSD1-	I/O	Multiplexed Source Input 1
10	HSD2+	I/O	Multiplexed Source Input 2
9	HSD2-	I/O	Multiplexed Source Input 2
SIGNAL INTERFACE			
7	/OE	I/O	Switch Enable
6	SEL	I/O	Switch Select
8	INTB/FLAGB	Output	OVP Interrupt Flag

FUSB252

Table 1. CC SWITCH TRUTH TABLE CONFIGURATION

V _{DD}	V _{ICC} Voltage	CC Switch Configuration
0 V – UVLO (Not Valid)	0 V – 5.8 V	OFF Dead Battery Rd Inserted
	5.8 V to 20 V	OFF Dead Battery Rd Inserted
2.7 V – 5.5 V (Valid)	0 V – 5.8 V	On
	5.8 V to 20 V	OFF (OVP)

Table 2. CC SWITCH TRUTH TABLE CONFIGURATION

/OE	SEL	VDD	HSD+ / HSD-	CC
1	0	Not Valid	X (Open/High-Z)	Dead Battery
0	0	Not Valid	X (Open/High-Z)	Dead Battery
1	X	Valid	X (Open/High-Z)	On
0	0	Valid	HSD1+ / HSD1-	On
0	1	Valid	HSD2+ / HSD2-	On

FUSB252

ABSOLUTE MAXIMUM RATINGS

Symbol	Parameter		Min	Max	Unit	
V _{VDD}	Supply Voltage from V _{DD}		-0.5	12.0	V	
V _{VICC}	V _{ICCx} , to GND		-0.5	24	V	
V _{SW}	V _{HSD±} , to GND		-5	16	V	
V _{OCC} , V _{SW}	V _{OCCx} , V _{HSDx±} to GND		-0.5	6	V	
V _{CONTROL}	DC Input Voltage (S, /OE)		-0.5	V _{VDD}	V	
I _{CCSW}	DC CC Switch Current			1.25	A	
I _{USBSW}	DC Output Current			100	mA	
I _{IK}	DC Input Diode Current		-50		mA	
T _{STORAGE}	Storage Temperature Range		-65	+150	°C	
T _J	Maximum Junction Temperature			+150	°C	
T _L	Lead Temperature (Soldering, 10 seconds)			+260	°C	
ESD	IEC 61000-4-2 System ESD	Connector Pins (V _{VDD±} , V _{VICCx} , V _{HSD±})	Air Gap	15		kV
			Contact	8		
	IEC 61000-4-5 Surge ESD	V _{VICCx} to GND		-24	24	V
		V _{HSD±} to GND		-16	16	V
	Human Body Model, JEDEC JESD22-A114	Power to GND		4		kV
		External Pins to GND (V _{HSD±} , V _{VICCx})				
		System Side Pin (V _{HSDx±} , V _{OCCx} , S, /OE, FLAGB)		2		
	Charged Device Model, JEDEC LESD22-C101	All Pins		1		

Stresses exceeding those listed in the Maximum Ratings table may damage the device. If any of these limits are exceeded, device functionality should not be assumed, damage may occur and reliability may be affected.

RECOMMENDED OPERATING CONDITIONS

Symbol	Parameter	Min	Typ	Max	Unit
V _{VDD}	Supply Voltage	2.7	4.2	5.5	V
V _{VICC}	Type C Input Voltage	0		5.5	V
V _{OCC}	Type C Output Voltage	0		5.5	V
I _{CCSW}	Maximum CC Switch Current			1	A
V _{CTRL}	Control Input Voltage (SEL, /OE)	-0.5		V _{VDD}	V
V _{SW}	HSD/USB Switch I/O Voltage	-0.5		4.5	V
T _A	Operating Temperature	-40		+85	°C

Functional operation above the stresses listed in the Recommended Operating Ranges is not implied. Extended exposure to stresses beyond the Recommended Operating Ranges limits may affect device reliability.

FUSB252

DC CHARACTERISTICS (Unless otherwise specified: Recommended T_A and T_J temperature ranges. All typical values are at $T_A = 25^\circ\text{C}$ and $V_{DD} = 4.2\text{ V}$ unless otherwise specified.)

Symbol	Characteristic	V_{DD} (V)	Conditions	$T_A = -40^\circ\text{C to } +85^\circ\text{C}$ $T_J = -40^\circ\text{C to } +125^\circ\text{C}$			Unit
				Min	Typ	Max	

BASIC OPERATION DEVICE

I_{CC}	Quiescent Supply Current	2.7 to 5.5	/OE = L, $I_{OUT} = 0$		9		μA
			/OE = H, $I_{OUT} = 0$		9		
I_{OFF}	Power-Off Leakage Current	0			3		μA

BASIC OPERATION CC SWITCH

$I_{SD(DB)}$	Dead Battery Supply Current	0 to UVLO	Dead Battery State Supply Current		15		μA
R_{ON}	CC Path On Resistance	2.7 to 5.5	$I_{OUT} = 200\text{ mA}$		350	480	$\text{m}\Omega$
V_{OV_TRIP}	Input OVP Lockout	2.7 to 5.5	V_{ICC} Rising		5.65	6.20	V
			V_{ICC} Falling		5.3		
V_{OV_HYS}	Input OVP Hysteresis	2.7 to 5.5			0.35		V
V_{UVLO}	Under-Voltage Lockout	2.7 to 5.5	V_{DD} Rising		2.55	2.70	V
			V_{DD} Falling		2.5		
TSD	Thermal Shutdown (Note 1)		Shutdown Threshold		150		$^\circ\text{C}$
			Return from Shutdown		130		
			Hysteresis		20		
R_d	Dead Battery Pull-Down Resistance	0 to UVLO	Dead Battery Resistance	4.08	5.10	6.12	$\text{k}\Omega$
			Voltage on Pin	0.25		2.6	

BASIC OPERATION HSD SWITCH

V_{OV_TRIP}	Input OVP Lockout	2.7 to 5.5	$V_{HSD\pm}$ Rising		4.4	5.0	V
			$V_{HSD\pm}$ Falling		4.1		
V_{OV_HYS}	Input OVP Hysteresis	2.7 to 5.5			0.3		V
V_{UV_TRIP}	Input Under-Voltage Lockout	2.7 to 5.5			-1.2		V
V_{IH}	Input Voltage High	2.7 to 5.5		1.3			V
V_{IL}	Input Voltage Low	2.7 to 5.5				0.5	V
I_{IN}	Control Input Leakage	2.7 to 5.5	$V_{SW} = 0$ to V_{DD}		0.1		μA
I_{OZ}	Off State Leakage	4.2	$0 \leq \text{HSDn} \leq 3.6\text{ V}$		2		μA
		4.2	$0 \leq \text{HSD1n}_\pm, \text{HSD2n}_\pm \leq 3.6\text{ V}$		100		nA
R_{ON}	HS Switch On Resistance	4.2	$V_{SW} = 0.4\text{ V}, I_{ON} = -8\text{ mA}$		5		Ω
ΔR_{ON}	HS Delta R_{ON}	4.2	$V_{SW} = 0.4\text{ V}, I_{ON} = -8\text{ mA}$		0.1		Ω

1. Guaranteed by characterization, not production tested.

FUSB252

AC CHARACTERISTICS (Unless otherwise specified: Recommended T_A and T_J temperature ranges. All typical values are at $T_A = 25^\circ\text{C}$ and $V_{DD} = 3.8\text{ V}$ unless otherwise specified.)

Symbol	Characteristic	V_{DD} (V)	Conditions	$T_A = -40^\circ\text{C to } +85^\circ\text{C}$ $T_J = -40^\circ\text{C to } +125^\circ\text{C}$			Unit
				Min	Typ	Max	

CC SWITCH TIMING PARAMETER

t_{OVP}	Response Time (Note 2)	2.7 to 5.5	$I_{OUT} = 0.2\text{ A}$, $C_L = 200\text{ pF}$, $V_{ICCX} = 5\text{ V to } 6\text{ V}$		0.5	1.0	μs
t_{ON}	Turn-On Time		V_{DD} Rising 2 V to 3 V		25		ms
T_{MBS}	Make-Before-Break	2.7 to 5.5	V_{DD} Rising 2 V to 3 V		600		ns

CC SWITCH CAPACITANCE

C_{ON}	Switch Path On Capacitance (Note 2)	2.7 to 5.5			100		μF
----------	-------------------------------------	------------	--	--	-----	--	---------------

CC SWITCH BANDWIDTH

BW	PD Traffic Bandwidth (Note 2)	2.7 to 5.5	$R_L = 50\ \Omega$, $C_L = 200\text{ pF}$		25		MHz
----	-------------------------------	------------	--	--	----	--	-----

HSD SWITCH TIMING PARAMETER

t_{OVP}	Response Time (Note 2)	2.7 to 5.5	$I_{OUT} = 0.2\text{ A}$, $V_{D\pm} = 4\text{ V to } 5\text{ V}$		0.5	1.0	μs
t_{ON}	Turn-On Time, /OE to Output (Note 2)	2.7 to 5.5	$R_L = 50\ \Omega$, $C_L = 5\text{ pF}$, $V_{SW} = 0.8\text{ V}$		25		ms
t_{OFF}	Turn-Off Time, /OE to Output (Note 2)	2.7 to 5.5	$R_L = 50\ \Omega$, $C_L = 5\text{ pF}$, $V_{SW} = 0.8\text{ V}$		100	400	ns
t_{PD}	Propagation Delay (Note 2)	2.7 to 5.5	$R_L = 50\ \Omega$, $C_L = 5\text{ pF}$		0.25		ns
T_{BBS}	Break-Before-Make (Note 2)	2.7 to 5.5	$R_L = 50\ \Omega$, $C_L = 5\text{ pF}$, $V_{SWx} = 0.8\text{ V SEL} = H \leftrightarrow L$		100		μs
O_{IRR}	Off Isolation	2.7 to 5.5	$R_L = 50\ \Omega$, $f = 240\text{ MHz}$		-25		dB
Xtalk	Non-Adjacent Channel Crosstalk	2.7 to 5.5	$R_L = 50\ \Omega$, $f = 240\text{ MHz}$		-40		dB

HSD SWITCH CAPACITANCE

C_{IN}	Control Pin Input Capacitance (Note 2)	0			1.5		μF
C_{ON}	HSD+ / HSD- On Capacitance (Note 2)	2.7 to 5.5	/OE = L, $f = 240\text{ MHz}$		4		μF
C_{OFF}	HSD1x / HSD2x Off Capacitance (Note 2)	2.7 to 5.5	/OE = H		2.5		μF

USB SWITCH BANDWIDTH

BW	-3 db Bandwidth (Note 2)	2.7 to 5.5	$R_L = 50\ \Omega$, $C_L = 0\text{ pF}$		1400		MHz
		2.7 to 5.5	$R_L = 50\ \Omega$, $C_L = 5\text{ pF}$		560		

USB HIGH-SPEED-RELATED

$t_{SK(P)}$	Skew of Opposite Transitions of the Same Output (Note 2)		$R_L = 50\ \Omega$, $C_L = 5\text{ pF}$		25		ps
t_J	Total Jitter (Note 2)		$R_L = 50\ \Omega$, $C_L = 5\text{ pF}$, $t_R = t_F = 500\text{ ps}$ (10-90%) at 480 Mbps (PRBS = $2^{15} - 1$)		200		ps

2. Guaranteed by characterization, not production tested.

FUSB252

OPERATION AND APPLICATION DESCRIPTION

Out of Spec Surge/Spike Voltage due to Hot Plug

The FUSB252 protects end systems against 20 V DC on the CC pin, in cases where the FUSB252 is tested to mimic a hot plug event, a fully charged cable connected to a power supply set to 20 V is used to zap the VICC pins of the device. In these cases, the inductance of the cable causes voltage spikes that are higher than the absolute maximum ratings of the of the VICC pins. These voltages can cause damage to the VOCC pins. This scenario does not occur in normal usage. The Type-C specification prevents the plug from having 20 V on VBUS from a PD source prior to a PD contract being completed. When the 20 V potential is on VBUS and shorted to the CC pin, it causes a detach and the voltage spikes are less likely to occur. The following reference circuit is required when the application calls for additional protection to protect against such event as hot plug.

Application Specific Schematic

- Place a 5 V to 6 V rated Zener TVS diode such as (CZRF52C5V6 or CD1005-Z5V1) on the VOCC pin, and a 5 Ω resistor to device ground to prevent the FUSB252 from being damaged during these tests. With this additional protection if is also important to select the right external VICC IEC TVS for the best overall performance.
- Without the additional protection the device by itself can withstand up to 9 V under the same hot plug condition.

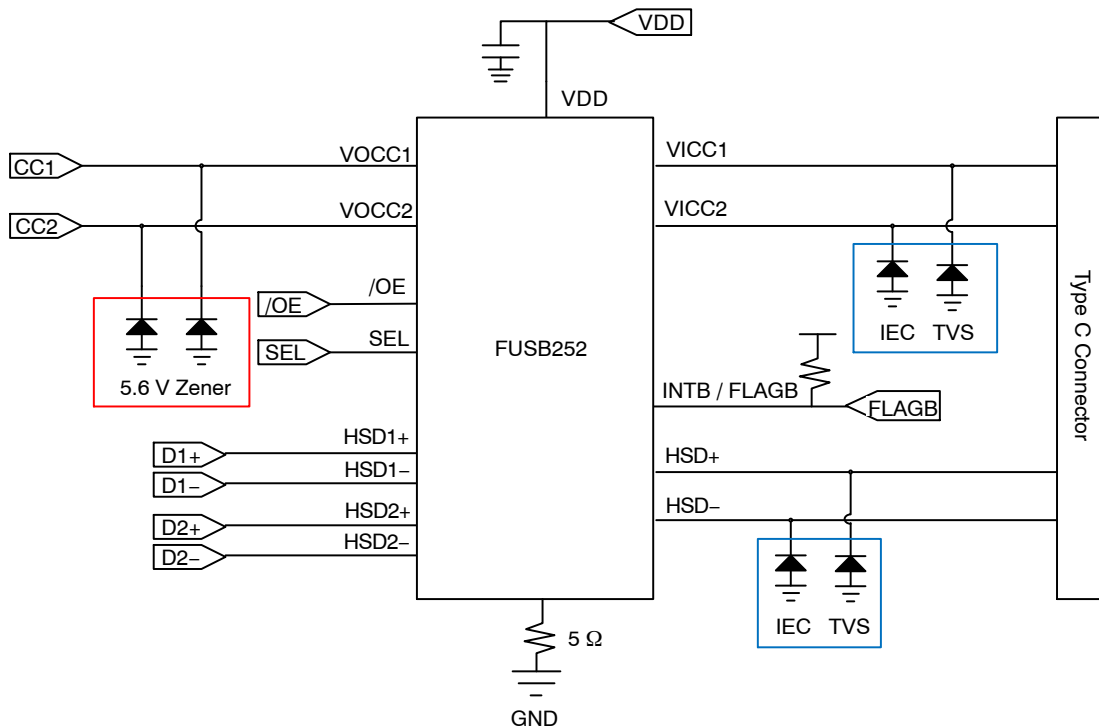

Figure 6. Reference Schematic

Over-Voltage Protection

When over-voltage event is detected, device will activate OVP to shutdown the switch within t_{OVB} as well as signal the FLAGB to indicate there is OV event to the system.

Fault Reporting

Upon the detection of an over-voltage event, the INTB/FLAGB signals the fault by activating LOW.

FUSB252

Type-C Solution Reference

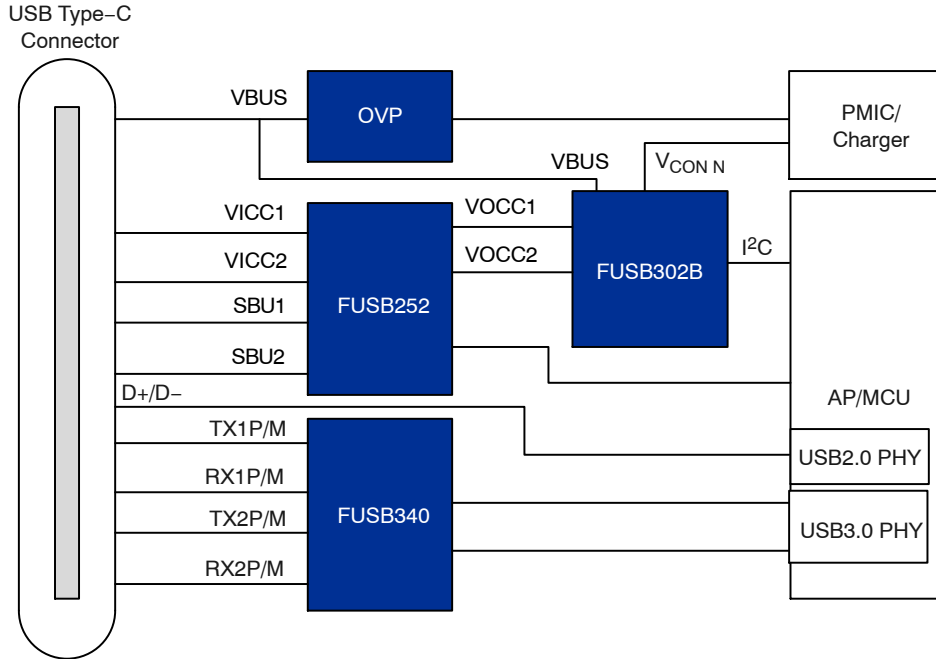

Figure 7. Example of Type-C Solution Reference (SBU)

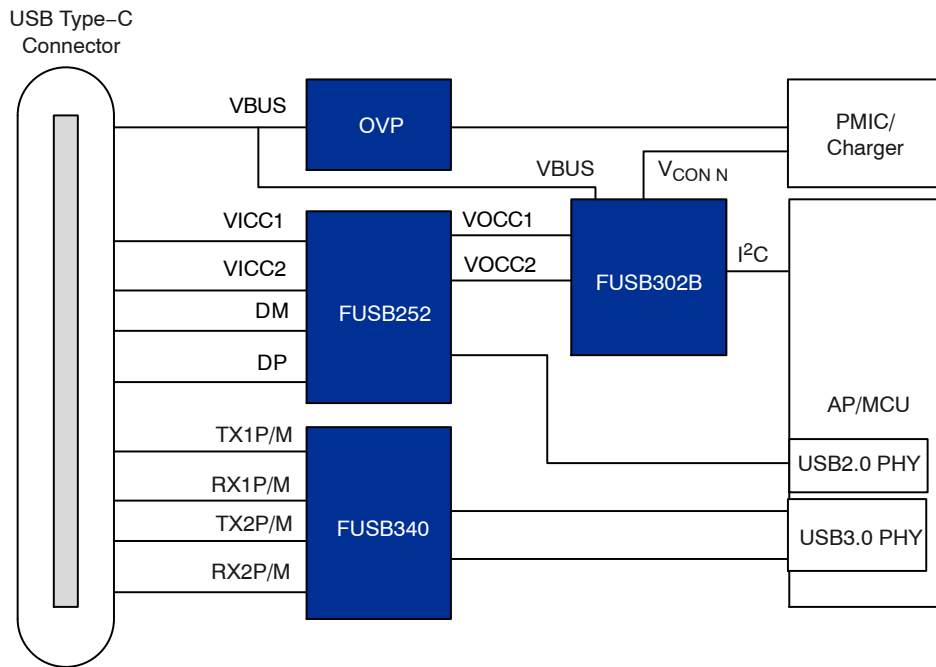

Figure 8. Example of Type-C Solution Reference (USB)

TEST DIAGRAMS

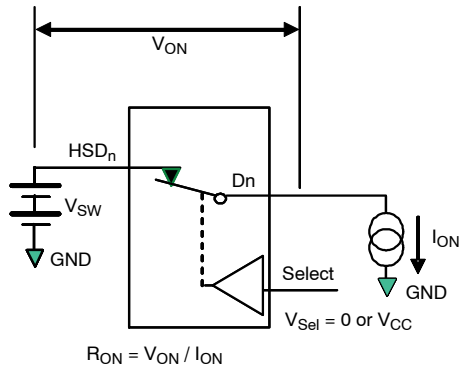
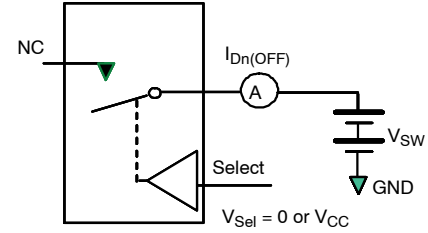
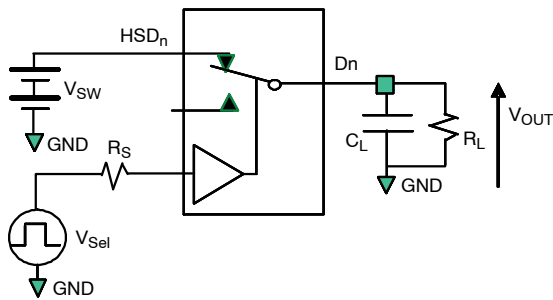

Figure 9. On Resistance



NOTE: Each switch port is tested separately.

Figure 10. Off Leakage



NOTE: R_L , R_S , and C_L are functions of the application environment (see AC Tables for specific values) C_L includes test fixture and stray capacitance.

Figure 11. AC Test Circuit Load

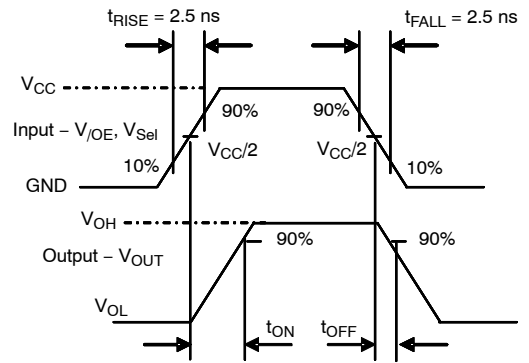

Figure 12. Turn-On / Turn-Off Waveforms

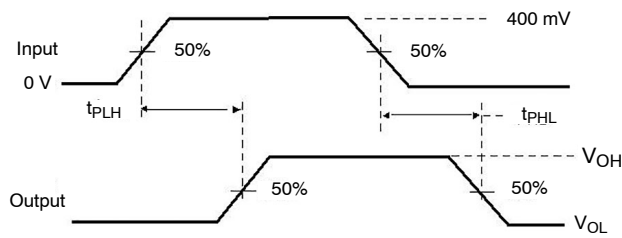

Figure 13. Propagation Delay ($t_{PLH} - 500$ ps)

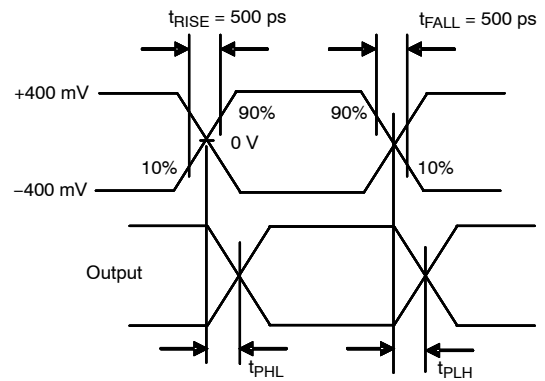

Figure 14. Intra-Pair Skew Test $t_{SK(P)}$

TEST DIAGRAMS (continued)

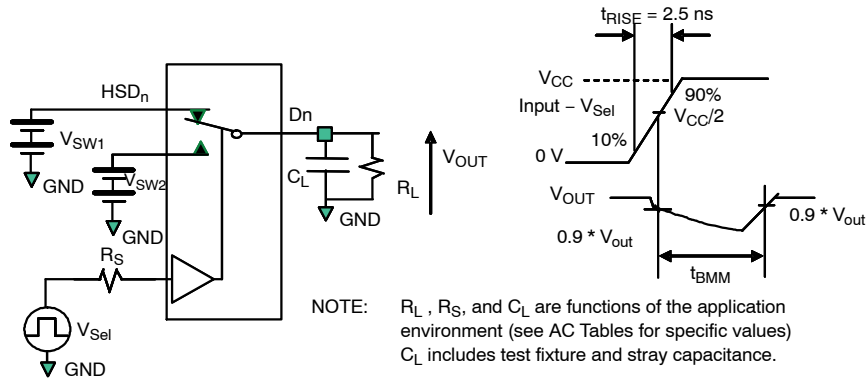

Figure 15. Break-Before-Make Interval Timing

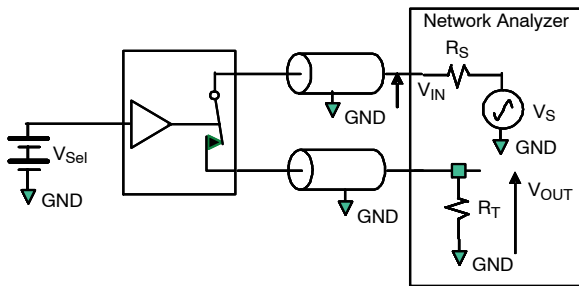
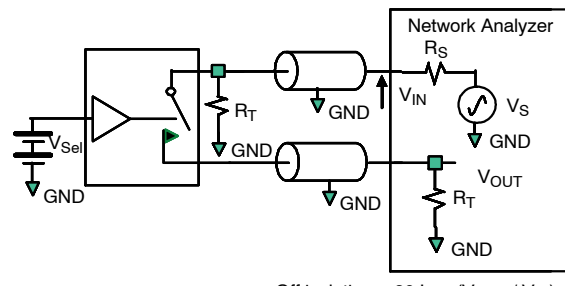

Figure 16. Bandwidth



Off isolation = $20 \text{ Log} (V_{OUT} / V_{IN})$

Figure 17. Channel Off Isolation

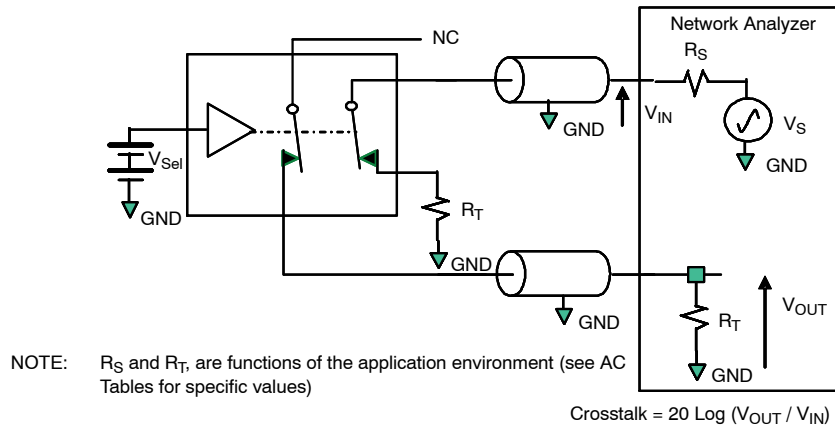

Figure 18. Non-Adjacent Channel-to-Channel Crosstalk

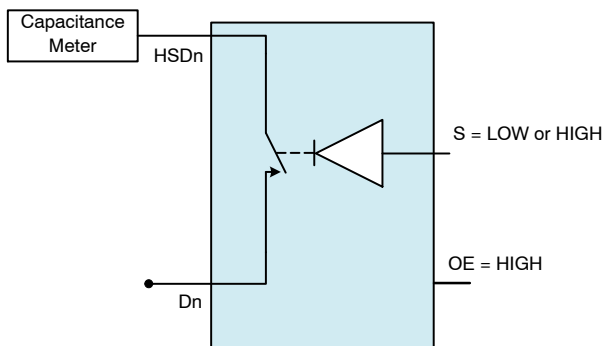

Figure 19. Channel Off Capacitance

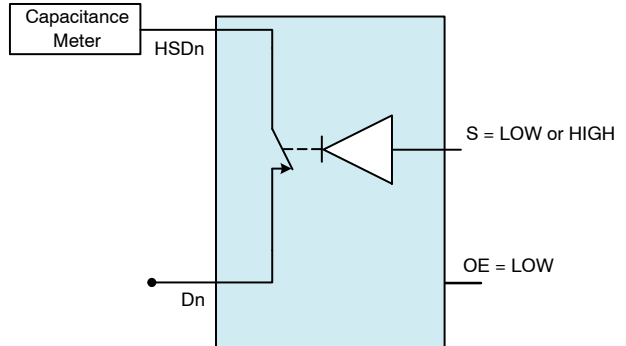
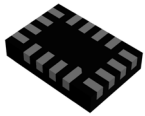

Figure 20. Channel On Capacitance

MECHANICAL CASE OUTLINE PACKAGE DIMENSIONS



UQFN16 1.80x2.60x0.50, 0.40P
CASE 523BF
ISSUE A

DATE 06 MAY 2024

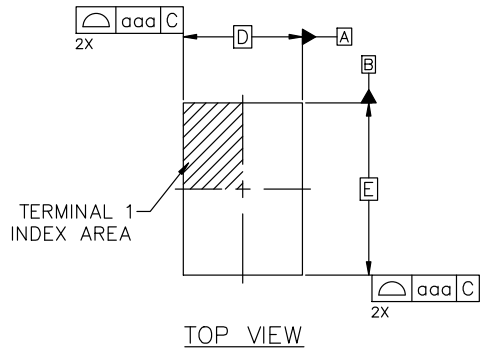

TOP VIEW

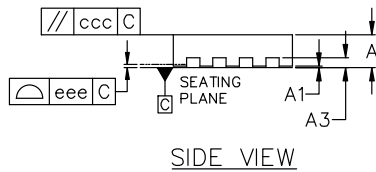

SIDE VIEW

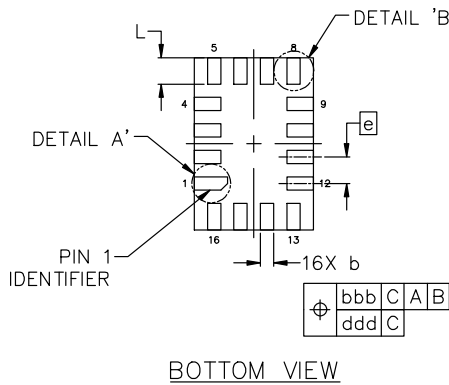

BOTTOM VIEW

NOTES:

1. DIMENSIONING AND TOLERANCING CONFORM TO ASME Y14.5M-2018.
2. ALL DIMENSIONS ARE IN MILLIMETERS, DEGREES IN ANGLE.
3. LAND PATTERN RECOMMENDATION IS EXISTING INDUSTRY LAND PATTERN.
4. TERMINAL SHAPE MAY VARY ACCORDING TO PACKAGE SUPPLIER, SEE TERMINAL SHAPE VARIANTS.

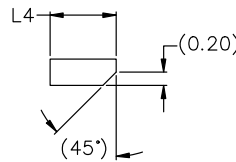

DETAIL 'A'
SCALE 2:1

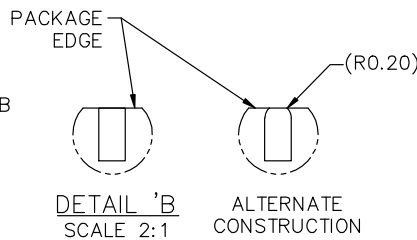

DETAIL 'B'
SCALE 2:1

DIM	MILLIMETERS		
	MIN	NOM	MAX
A	0.45	0.50	0.55
A1	0.00	---	0.05
A3	0.10	0.15	0.20
b	0.15	0.20	0.25
D	1.80 BSC		
E	2.60 BSC		
e	0.40 BSC		
L	0.35	0.40	0.45
L4	0.45	0.50	0.55
TOLERANCES FOR FEATURE CONTROL FRAME			
aaa	0.05		
bbb	0.10		
ccc	0.10		
ddd	0.05		
eee	0.05		

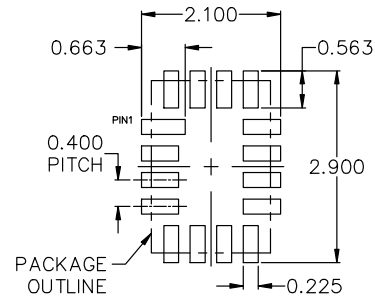

RECOMMENDED MOUNTING FOOTPRINT*

*FOR ADDITIONAL INFORMATION ON OUR Pb-FREE STRATEGY AND SOLDERING DETAILS, PLEASE DOWNLOAD THE ONSEMI SOLDERING AND MOUNTING TECHNIQUES REFERENCE MANUAL, SOLDERRM/D.

DOCUMENT NUMBER:	98AON13709G	Electronic versions are uncontrolled except when accessed directly from the Document Repository. Printed versions are uncontrolled except when stamped "CONTROLLED COPY" in red.
DESCRIPTION:	UQFN16 1.80x2.60x0.50, 0.40P	PAGE 1 OF 1

onsemi and ONSEMI are trademarks of Semiconductor Components Industries, LLC dba onsemi or its subsidiaries in the United States and/or other countries. onsemi reserves the right to make changes without further notice to any products herein. onsemi makes no warranty, representation or guarantee regarding the suitability of its products for any particular purpose, nor does onsemi assume any liability arising out of the application or use of any product or circuit, and specifically disclaims any and all liability, including without limitation special, consequential or incidental damages. onsemi does not convey any license under its patent rights nor the rights of others.

onsemi, **Onsemi**, and other names, marks, and brands are registered and/or common law trademarks of Semiconductor Components Industries, LLC dba "**onsemi**" or its affiliates and/or subsidiaries in the United States and/or other countries. **onsemi** owns the rights to a number of patents, trademarks, copyrights, trade secrets, and other intellectual property. A listing of **onsemi**'s product/patent coverage may be accessed at www.onsemi.com/site/pdf/Patent-Marking.pdf. **onsemi** reserves the right to make changes at any time to any products or information herein, without notice. The information herein is provided "as-is" and **onsemi** makes no warranty, representation or guarantee regarding the accuracy of the information, product features, availability, functionality, or suitability of its products for any particular purpose, nor does **onsemi** assume any liability arising out of the application or use of any product or circuit, and specifically disclaims any and all liability, including without limitation special, consequential or incidental damages. Buyer is responsible for its products and applications using **onsemi** products, including compliance with all laws, regulations and safety requirements or standards, regardless of any support or applications information provided by **onsemi**. "Typical" parameters which may be provided in **onsemi** data sheets and/or specifications can and do vary in different applications and actual performance may vary over time. All operating parameters, including "Typicals" must be validated for each customer application by customer's technical experts. **onsemi** does not convey any license under any of its intellectual property rights nor the rights of others. **onsemi** products are not designed, intended, or authorized for use as a critical component in life support systems or any FDA Class 3 medical devices or medical devices with a same or similar classification in a foreign jurisdiction or any devices intended for implantation in the human body. Should Buyer purchase or use **onsemi** products for any such unintended or unauthorized application, Buyer shall indemnify and hold **onsemi** and its officers, employees, subsidiaries, affiliates, and distributors harmless against all claims, costs, damages, and expenses, and reasonable attorney fees arising out of, directly or indirectly, any claim of personal injury or death associated with such unintended or unauthorized use, even if such claim alleges that **onsemi** was negligent regarding the design or manufacture of the part. **onsemi** is an Equal Opportunity/Affirmative Action Employer. This literature is subject to all applicable copyright laws and is not for resale in any manner.

ADDITIONAL INFORMATION

TECHNICAL PUBLICATIONS:

Technical Library: www.onsemi.com/design/resources/technical-documentation
onsemi Website: www.onsemi.com

ONLINE SUPPORT: www.onsemi.com/support

For additional information, please contact your local Sales Representative at www.onsemi.com/support/sales

Looking for pricing, stock, or lifecycle information?

Click below to explore more details on WIN SOURCE:

- ⊖ [View FUSB252UMX](#) on WIN SOURCE
- ⊖ [ON Semiconductor](#) Information

Optimize Your Supply Chain with WIN SOURCE Solutions

- ✓ Global Sourcing Solution
- ✓ Obsolete Management
- ✓ Cost Control Management
- ✓ Shortage Management
- ✓ Alternative Solution
- ✓ Excess Inventory Management