



**THE DATASHEET OF
FS32K146HRT0CLLT**



S32K1XX

S32K1xx Data Sheet

Caution

- S32K148, S32K142, S32K146, and S32K116 specific information is preliminary until these devices are qualified.

Key Features

- Operating characteristics
 - Voltage range: 2.7 V to 5.5 V
 - Ambient temperature range: -40 °C to 105 °C for HSRUN, -40 °C to 125 °C for RUN
- ARM™ Cortex-M4F/M0+ core, 32-bit CPU
 - Supports up to 112 MHz frequency (HSRUN) with 1.25 Dhrystone MIPS per MHz
 - ARM Core based on the ARMv7 Architecture and Thumb®-2 ISA
 - Integrated Digital Signal Processor (DSP)
 - Configurable Nested Vectored Interrupt Controller (NVIC)
 - Single Precision Floating Point Unit (FPU)
- Clock interfaces
 - 4 - 40 MHz fast external oscillator (SOSC)
 - 48 MHz Fast Internal RC oscillator (FIRC)
 - 8 MHz Slow Internal RC oscillator (SIRC)
 - 128 kHz Low Power Oscillator (LPO)
 - Up to 112 MHz (HSRUN) System Phased Lock Loop (SPLL)
 - Up to 50 MHz DC external square wave input clock
 - Real Time Counter (RTC)
- Power management
 - Low-power ARM Cortex-M4F/M0+ core with excellent energy efficiency
 - Power Management Controller (PMC) with multiple power modes: HSRUN, Run, Stop, VLPR, and VLPS
 - Supports peripheral specific clock gating. Only specific peripherals remain working in low power modes.
- Memory and memory interfaces
 - Up to 2 MB program flash memory with ECC
 - 64 KB FlexNVM for data flash memory with ECC and EEPROM emulation
 - Up to 256 KB SRAM with ECC
 - Up to 4 KB of FlexRAM for use as SRAM or EEPROM emulation
 - Up to 4 KB Code cache to minimize performance impact of memory access latencies
 - QuadSPI with HyperBus™ support
- Mixed-signal analog
 - Up to two 12-bit Analog-to-Digital Converter (ADC) with up to 32 channel analog inputs per module
 - One Analog Comparator (CMP) with internal 8-bit Digital to Analog Converter (DAC)
- Debug functionality
 - Serial Wire JTAG Debug Port (SWJ-DP) combines
 - Debug Watchpoint and Trace (DWT)
 - Instrumentation Trace Macrocell (ITM)
 - Test Port Interface Unit (TPIU)
 - Flash Patch and Breakpoint (FPB) Unit
- Human-machine interface (HMI)
 - Up to 156 GPIO pins with interrupt functionality
 - Non-Maskable Interrupt (NMI)
- Communications interfaces
 - Up to three Low Power Universal Asynchronous Receiver/Transmitter (LPUART) modules with DMA support and low power availability
 - Up to three Low Power Serial Peripheral Interface (LPSPI) modules with DMA support and low power availability
 - Up to two Low Power Inter-Integrated Circuit (LPI2C) modules with DMA support and low power availability
 - Up to three FlexCAN modules (with optional CAN-FD support)
 - FlexIO module for flexible and high performance serial interfaces

This document contains information on a product under development. NXP reserves the right to change or discontinue this product without notice.

Preliminary



- Reliability, safety and security
 - HW Security Engine (CSEc)
 - Internal watchdog (WDOG)
 - External Watchdog monitor (EWM) module
 - Error-Correcting Code (ECC) on flash and SRAM memories
 - Cyclic Redundancy Check (CRC) module
 - 128-bit Unique Identification (ID) number
 - System Memory Protection Unit (System MPU)
- Timing and control
 - Up eight independent 16-bit FlexTimers (FTM) module, offering up to 64 standard channels (IC/OC/PWM)
 - One 16-bit Low Power Timer (LPTMR) with flexible wake up control
 - Two Programmable Delay Blocks (PDB) with flexible trigger system
 - One 32-bit Low Power Interrupt Timer (LPIT) with 4 channels
 - 32-bit Real Time Counter (RTC)
- I/O and package
 - 32-pin QFN, 48-pin LQFP, 64-pin LQFP, 100-pin LQFP, MAPBGA-100, 144-pin LQFP, 176-pin LQFP package options
- 16 channel DMA with up to 63 request sources using DMAMUX

Table of Contents

| | | | | | |
|---------|--|----|---------|---|----|
| 1 | Block diagram..... | 4 | 6.2.5 | SPLL electrical specifications | 27 |
| 2 | Feature comparison..... | 5 | 6.3 | Memory and memory interfaces..... | 27 |
| 3 | Ordering parts..... | 7 | 6.3.1 | Flash memory module (FTFC) electrical specifications..... | 27 |
| 3.1 | Determining valid orderable parts | 7 | 6.3.1.1 | Flash timing specifications — commands..... | 27 |
| 3.2 | Ordering information | 8 | 6.3.1.2 | Reliability specifications..... | 29 |
| 4 | General..... | 9 | 6.3.2 | QuadSPI AC specifications..... | 30 |
| 4.1 | Absolute maximum ratings..... | 9 | 6.4 | Analog modules..... | 34 |
| 4.2 | Voltage and current operating requirements..... | 10 | 6.4.1 | ADC electrical specifications..... | 34 |
| 4.3 | Thermal operating characteristics..... | 11 | 6.4.1.1 | 12-bit ADC operating conditions..... | 34 |
| 4.4 | Power and ground pins..... | 12 | 6.4.1.2 | 12-bit ADC electrical characteristics..... | 36 |
| 4.5 | LVR, LVD and POR operating requirements..... | 13 | 6.4.2 | CMP with 8-bit DAC electrical specifications..... | 37 |
| 4.6 | Power mode transition operating behaviors..... | 14 | 6.5 | Communication modules..... | 41 |
| 4.7 | Power consumption..... | 15 | 6.5.1 | LPUART electrical specifications..... | 41 |
| 4.7.1 | Modes configuration..... | 18 | 6.5.2 | LPSPi electrical specifications..... | 41 |
| 4.8 | ESD handling ratings..... | 18 | 6.5.3 | LPI2C electrical specifications..... | 48 |
| 4.9 | EMC radiated emissions operating behaviors..... | 18 | 6.5.4 | FlexCAN electrical specifications..... | 49 |
| 5 | I/O parameters..... | 18 | 6.5.5 | SAI electrical specifications..... | 49 |
| 5.1 | AC electrical characteristics..... | 18 | 6.5.6 | Ethernet AC specifications..... | 51 |
| 5.2 | General AC specifications..... | 19 | 6.5.7 | Clockout frequency..... | 54 |
| 5.3 | DC electrical specifications at 3.3 V Range..... | 19 | 6.6 | Debug modules..... | 54 |
| 5.4 | DC electrical specifications at 5.0 V Range..... | 20 | 6.6.1 | SWD electrical specifications | 54 |
| 5.5 | AC electrical specifications at 3.3 V range | 21 | 6.6.2 | Trace electrical specifications..... | 56 |
| 5.6 | AC electrical specifications at 5 V range | 22 | 6.6.3 | JTAG electrical specifications..... | 57 |
| 5.7 | Standard input pin capacitance..... | 22 | 7 | Thermal attributes..... | 60 |
| 5.8 | Device clock specifications..... | 22 | 7.1 | Description..... | 60 |
| 6 | Peripheral operating requirements and behaviors..... | 23 | 7.2 | Thermal characteristics..... | 60 |
| 6.1 | System modules..... | 23 | 7.3 | General notes for specifications at maximum junction temperature..... | 64 |
| 6.2 | Clock interface modules..... | 23 | 8 | Dimensions..... | 65 |
| 6.2.1 | External System Oscillator electrical specifications.... | 23 | 8.1 | Obtaining package dimensions | 65 |
| 6.2.2 | External System Oscillator frequency specifications . | 25 | 9 | Pinouts..... | 66 |
| 6.2.3 | System Clock Generation (SCG) specifications..... | 26 | 9.1 | Package pinouts and signal descriptions..... | 66 |
| 6.2.3.1 | Fast internal RC Oscillator (FIRC) electrical specifications..... | 26 | 10 | Revision History..... | 66 |
| 6.2.3.2 | Slow internal RC oscillator (SIRC) electrical specifications | 26 | | | |
| 6.2.4 | Low Power Oscillator (LPO) electrical specifications | 27 | | | |

1 Block diagram

Following figures show superset high level architecture block diagrams of S32K14x series and S32K11x series respectively. Other devices within the family have a subset of the features. See [Feature comparison](#) for chip specific values.

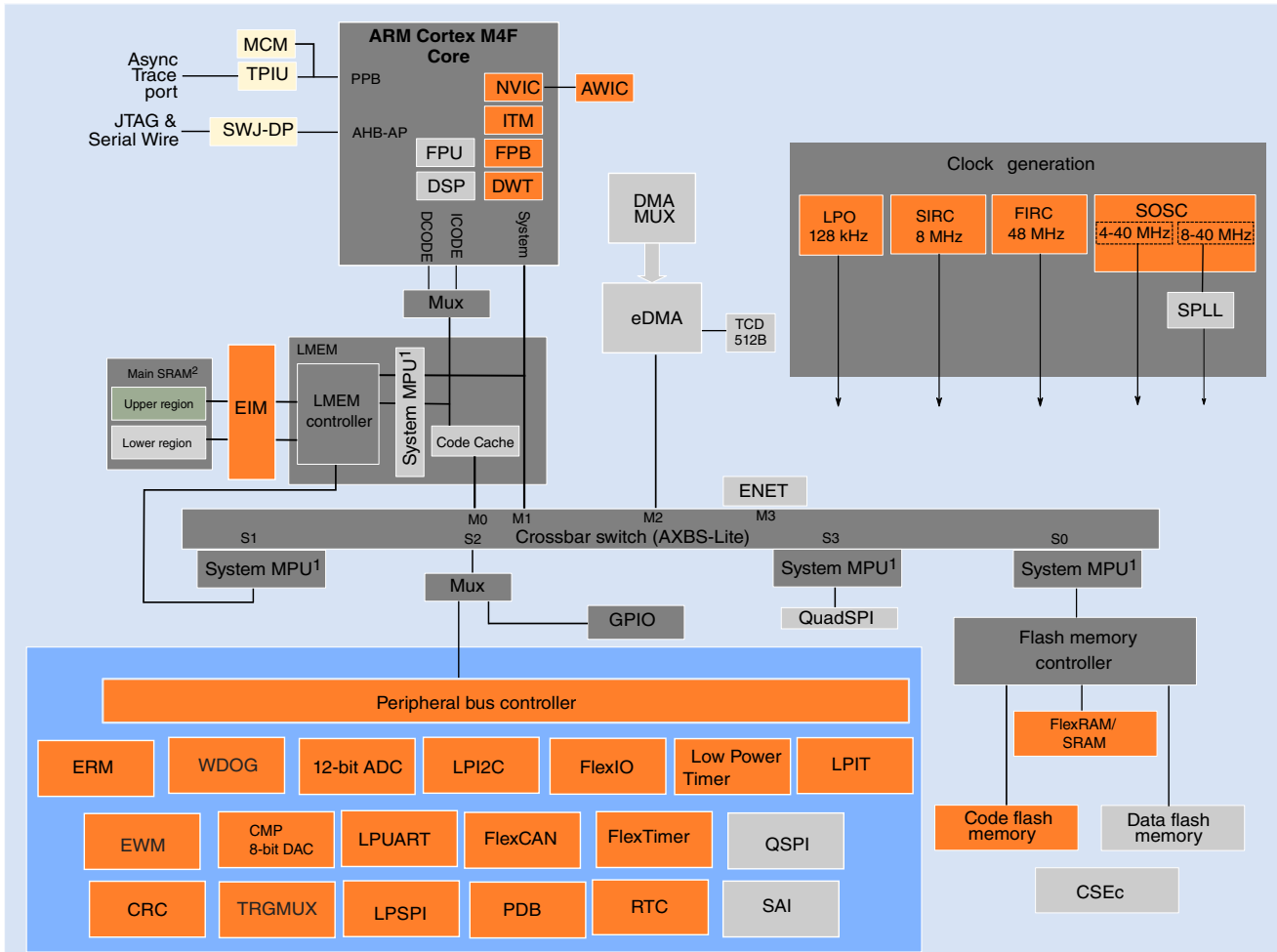

1: On this device, NXP's system MPU implements the safety mechanisms to prevent masters from accessing restricted memory regions. This system MPU provides memory protection at the level of the Crossbar Switch. Each Crossbar master (Core, DMA, Ethernet) can be assigned different access rights to each protected memory region. The ARM M4 core version in this family does not integrate the ARM Core MPU, which would concurrently monitor only core-initiated memory accesses. In this document, the term MPU refers to NXP's system MPU.

2: For the device-specific sizes, see the "On-chip SRAM sizes" table in the "Memories and Memory Interfaces" chapter of the S32K14x Series Reference Manual.

Key:

| |
|---|
| Device architectural IP on all S32K devices |
| Peripherals present on all S32K devices |
| Peripherals present on selected S32K devices (see the "Feature Comparison" section in the RM) |

Figure 1. High-level architecture diagram for the S32K14x family

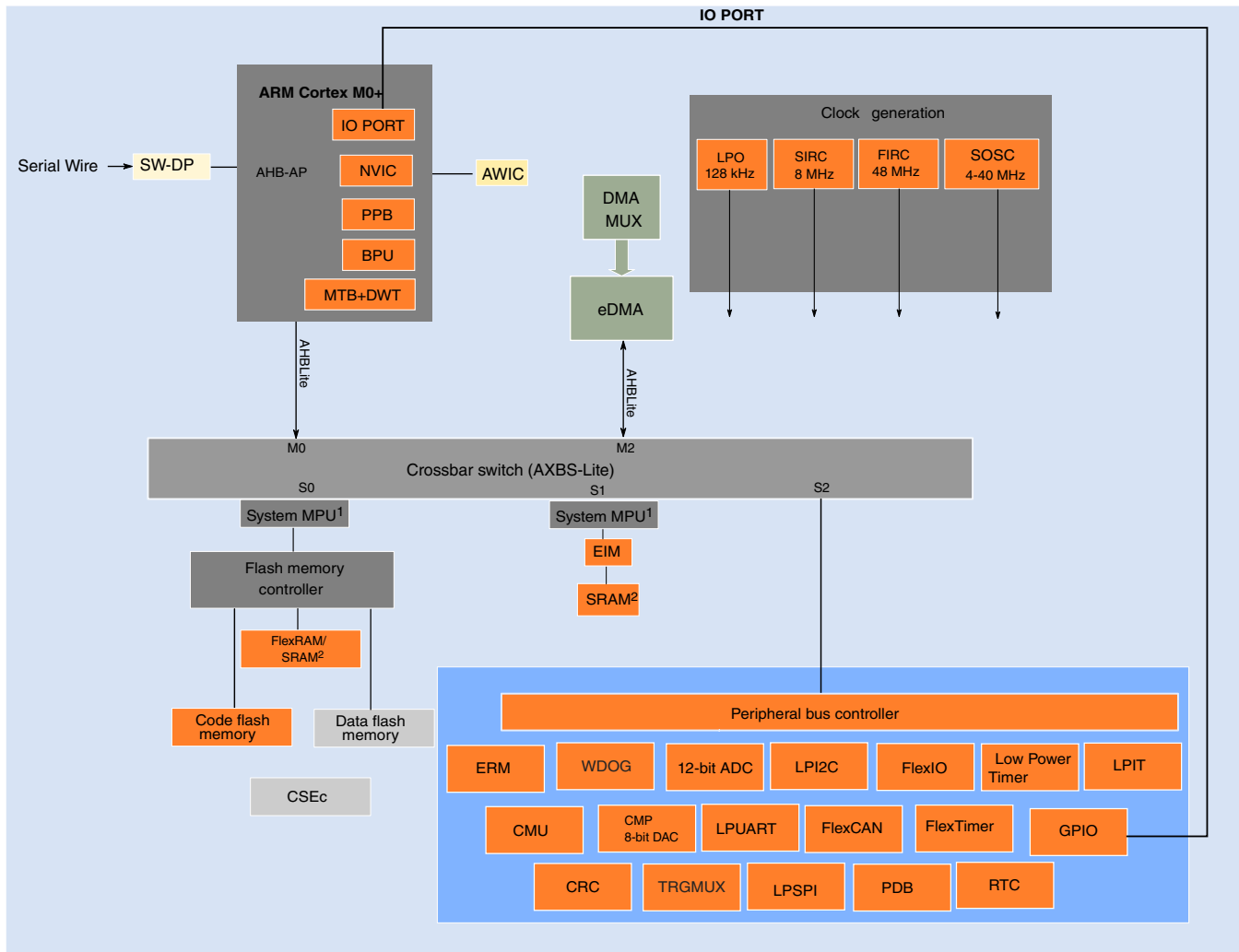

1: On this device, NXP's system MPU implements the safety mechanisms to prevent masters from accessing restricted memory regions. This system MPU provides memory protection at the level of the Crossbar Switch. Crossbar master (Core, DMA) can be assigned different access rights to each protected memory region. The ARM M0+ core version in this family does not integrate the ARM Core MPU, which would concurrently monitor only core-initiated memory accesses. In this document, the term MPU refers to NXP's system MPU.

2: For the device-specific sizes, see the "On-chip SRAM sizes" table in the "Memories and Memory Interfaces" chapter of the S32K1xx Series Reference Manual.

| |
|---|
| Device architectural IP on all S32K devices |
| Peripherals present on all S32K devices |
| Peripherals present on selected S32K devices (see the "Feature Comparison" section in the RM) |

Figure 2. High-level architecture diagram for the S32K11x family

2 Feature comparison

The following figure summarizes the memory and package options for the S32K product series and demonstrates where this device fits within the overall series. All devices which share a common package are pin-to-pin compatible.

Feature comparison

| | | S32K11x | | S32K14x | | | |
|---|--|---|--------------------------------|---|-----------------------------------|---|--|
| Parameter | | K116 | K118 | K142 | K144 | K146 | K148 |
| System | Core | ARM® Cortex™-M0+ | | ARM® Cortex™-M4F | | | |
| | Frequency | 48 MHz | | up to 112 MHz (HSRUN) | | | |
| | IEEE-754 FPU | ○ | | ● | | | |
| | HW security module (CSEc) ¹ | ● | | ● | | | |
| | CRC module | 1x | | 1x | | | |
| | ISO 26262 | capable up to ASIL-B | | capable up to ASIL-B | | | |
| | Peripheral speed | up to 48 MHz | | up to 112 MHz (HSRUN) | | | |
| | Crossbar | ● | | ● | | | |
| | DMA | ● | | ● | | | |
| | EWM | ○ | | ● | | | |
| | Memory protection unit | ● | | ● | | | |
| | FIRC CMU | ● | | ○ | | | |
| | Watchdog | 1x | | 1x | | | |
| | Low power modes | ● | | ● | | | |
| | HSRUN mode | ○ | | ● | | | |
| | Number of I/Os | up to 43 | up to 58 | up to 89 | up to 128 | up to 156 | |
| | Single supply voltage | 2.7 - 5.5 V | | 2.7 - 5.5 V | | | |
| Operating temperature (T _a) Temperature ambient | -40 to +85°C / +105°C / +125°C | | -40 to +85°C / +105°C / +125°C | | | | |
| Memory | Flash | 128 KB | 256 KB | 256 KB | 512 KB | 1 MB | 2 MB ² |
| | Error correction code (ECC) | ● | | ● | | | |
| | System RAM (including FlexRAM and MTB) | 17 KB | 25 KB | 32 KB | 64 KB | 128 KB | 256 KB |
| | FlexRAM (also available as system RAM) | 2 KB | | 4 KB | | | |
| | Cache | ○ | | 4 KB | | | |
| | EEPROM emulated by FlexRAM ¹ | 2 KB (up to 32 KB D-Flash) | | 4 KB (up to 64 KB D-Flash) | | | 4 KB (up to 512 KB D-Flash as a part of 2 MB Flash) ³ |
| | External memory interface | ○ | | ○ | | | QuadSPI incl. HyperBus™ |
| Timer | Low power interrupt timer | 1x | | 1x | | | |
| | FlexTimer (16-bit counter) 8 channels | 2x (16) | | 4x (32) | | 6x (48) | 8x (64) |
| | Low power timer (LPTMR) | 1x | | 1x | | | |
| | Real time counter (RTC) | 1x | | 1x | | | |
| | Programmable delay block (PDB) | 1x | | 2x | | | |
| Analog | Trigger mux (TRGMUX) | 1x (43) | 1x (45) | 1x (64) | 1x (73) | 1x (81) | |
| | 12-bit SAR ADC (1 MSPS each) | 1x (14) | 1x (16) | 2x (16) | 2x (24) | 2x (32) | |
| | Comparator with 8-bit DAC | 1x | | 1x | | | |
| Communication | 100 Mbit IEEE-1588 ethernet MAC | ○ | | ○ | | 1x | |
| | Serial audio interface (AC97, TDM, I2S) | ○ | | ○ | | 2x | |
| | Low power UART/LIN (Supports LIN protocol versions 1.3, 2.0, 2.1, and SAE J2602) | 2x | | 2x | 3x | | |
| | Low power SPI | 1x | 2x | 2x | 3x | | |
| | Low power I2C | 1x | | 1x | | | 2x |
| | FlexCAN (CAN-FD ISO/CD 11898-1) | 1x (1x with FD) | | 2x (1x with FD) | 3x (1x with FD) | 3x (2x with FD) | 3x (3x with FD) |
| IDEs | FlexIO (8 pins configurable as UART, SPI, I2C, I2S) | 1x | | 1x | | | |
| | Debug & trace | SWD, MTB (1 KB), JTAG ⁴ | | SWD, JTAG (ITM, SWV, SWO) | | | SWD, JTAG (ITM, SWV, SWO), ETM |
| Other | Ecosystem (IDE, compiler, debugger) | NXP S32 Design Studio (GCC) + SDK, IAR, GHS, COSMIC, Lauterbach, iSystems | | NXP S32 Design Studio (GCC) + SDK, IAR, GHS, COSMIC, Lauterbach, iSystems | | | |
| | Packages | QFN-32 LQFP-48 | LQFP-48 LQFP-64 | LQFP-64 LQFP-100 | LQFP-64 LQFP-100 MAPBGA-100 | LQFP-64 MAPBGA-100 LQFP-100 LQFP-144 | MAPBGA-100 LQFP-144 LQFP-176 |

LEGEND:

- Not implemented
- Available on the device
- ¹ No FTFC commands, including CSE commands (CSEc parts) are available when chip is in VLPR or HSRUN mode.
- ² Available when EEPROM, CSEc and Data Flash are not used. Else only up to 1,984 KB is available for Program Flash.
- ³ Up to 64 KB of flash is used as EEPROM backup and the remaining 448 KB of the last 512 KB block can be used as Data flash or Program flash. See chapter FTFC for details.
- ⁴ Only for BSR

Figure 3. S32K1xx product series comparison

3 Ordering parts

3.1 Determining valid orderable parts

To determine the orderable part numbers for this device, go to www.nxp.com and perform a part number search. Additionally see the attachment *S32K_Part_Numbers.xlsx* .

NOTE

Not all part number combinations exist

3.2 Ordering information

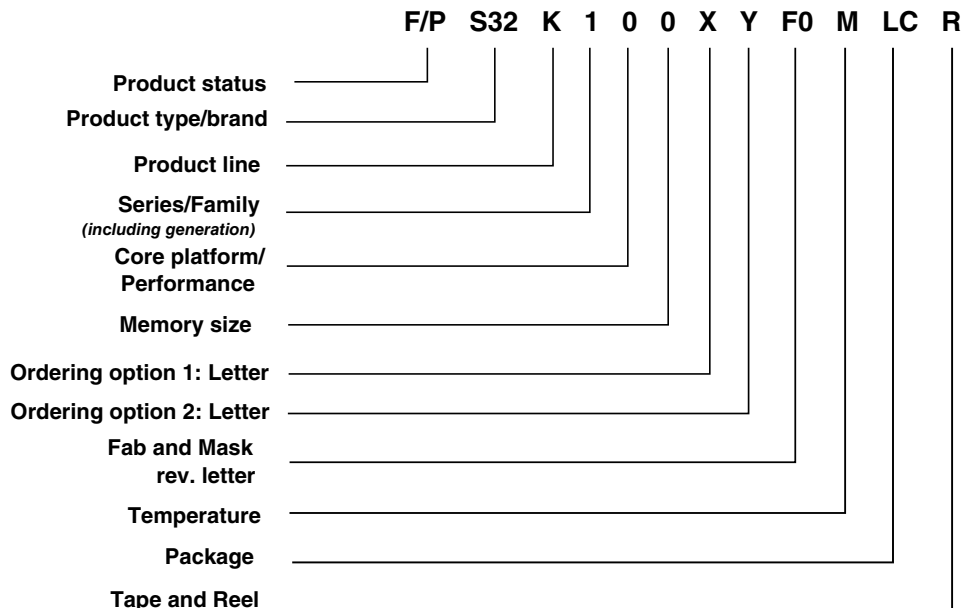

Product status

P: Prototype
F: Qualified ordering P/N

Product type/brand

S32: Automotive 32-bit MCU

Product line

K: ARM Cortex MCUs
M: MagniV/Mixed Signal

Series/Family

1: 1st product series
2: 2nd product series

Core platform/Performance

1: ARM Cortex M0+
4: ARM Cortex M4F

Memory size

| | | | | |
|-----|-------|-------|-------|-------|
| | 2 | 4 | 6 | 8 |
| M0+ | 32 K | 64 K | 128 K | 256 K |
| M4F | 256 K | 512 K | 1 M | 2 M |

Ordering option

X: Speed
B: 48 MHz without DMA (only for S32K11x)
L: 48 MHz with DMA (only for S32K11x)
M: 64 MHz
H: 80 MHz
U: 112 MHz

Y: Optional feature

N: No/None
R: Max. RAM
F: CAN-FD and FlexIO including max. RAM
S: Security including max. RAM
A: CAN-FD, FlexIO, and Security including max. RAM
E: Ethernet and audio including max. RAM
J: CAN FD, FlexIO, Security, Ethernet and audio including max. RAM

Fab and Mask rev. letter

Fx: ATMC
Tx: GF
XX: Flex #

x0: 1st fab revision
x1: 2nd fab revision

Temperature

C: -40C to 85C
V: -40C to 105C
M: -40C to 125C

Package

| Pins | LQFP | LQFP-EP | QFN | BGA |
|------|------|---------|-----|-----|
| 32 | LC | - | FM | - |
| 48 | LF | KF | FT | - |
| 64 | LH | KH | - | - |
| 100 | LL | - | - | MH |
| 144 | LQ | - | - | - |
| 176 | LU | - | - | - |

Tape and Reel

T: Trays and Tubes
R: Tape and Reel

Figure 4. Ordering information

4 General

4.1 Absolute maximum ratings

NOTE

Functional operating conditions appear in the DC electrical characteristics. Absolute maximum ratings are stress ratings only, and functional operation at the maximum values is not guaranteed. See footnotes in the following table for specific conditions.

Stress beyond the listed maximum values may affect device reliability or cause permanent damage to the device.

All the limits defined in the datasheet specification must be honored together and any violation to any one or more will not guarantee desired operation.

Table 1. Absolute maximum ratings

| Symbol | Parameter | Conditions ¹ | Min | Max | Unit |
|------------------------------------|--|-------------------------|-----------|------------------|------|
| V_{DD} ² | 2.7 V - 5V input supply voltage | — | -0.3 | 5.8 ³ | V |
| V_{REFH} | 3.3 V / 5.0 V ADC high reference voltage | — | -0.3 | 5.8 ³ | V |
| $I_{INJPAD_DC_ABS}$ ⁴ | Continuous DC input current (positive / negative) that can be injected into an I/O pin | — | -3 | +3 | mA |
| V_{IN_DC} | Continuous DC Voltage on any I/O pin with respect to V_{SS} | — | -0.8 | 5.8 ⁵ | V |
| $I_{INJSUM_DC_ABS}$ | Sum of absolute value of injected currents on all the pins (Continuous DC limit) | — | — | 30 | mA |
| T_{ramp} ⁶ | Supply ramp rate | — | 0.5 V/min | 500 V/ms | — |
| T_A ⁷ | Ambient temperature | — | -40 | 125 | °C |
| T_{STG} | Storage temperature | — | -55 | 165 | °C |
| $V_{IN_TRANSIENT}$ | Transient overshoot voltage allowed on I/O pin beyond V_{IN_DC} limit | — | — | 6.8 ⁸ | V |

- All voltages are referred to V_{SS} unless otherwise specified.
- As V_{DD} varies between the minimum value and the absolute maximum value the analog characteristics of the I/O and the ADC will both change. See section [I/O parameters](#) and [ADC electrical specifications](#) respectively for details.
- 60 s lifetime – No restrictions i.e. The part can switch.
10 hours lifetime – Device in reset i.e. The part cannot switch.
- When input pad voltage levels are close to V_{DD} or V_{SS} , practically no current injection is possible.
- While respecting the maximum current injection limit
- Limit applies to both maximum absolute maximum ramp rate and typical operating conditions.
- T_J (Junction temperature)=135 °C. Assumes T_A =125 °C for RUN mode

General

T_J (Junction temperature)=125 °C. Assumes T_A =105 °C for HSRUN mode

- Assumes maximum θ_{JA} for 2s2p board. See [Thermal characteristics](#)

8. 60 seconds lifetime; device in reset (no outputs enabled/toggling)

4.2 Voltage and current operating requirements

NOTE

Full functionality/specifications cannot be guaranteed when voltage drops below 2.7 V.

Table 2. Voltage and current operating requirements 1

| Symbol | Description | Min. | Max. | Unit | Notes |
|------------------------|---|------------------|-----------------|------|-------|
| V_{DD}^2 | Supply voltage | 2.7 ³ | 5.5 | V | 4 |
| V_{DD_OFF} | Voltage allowed to be developed on V_{DD} pin when it is not powered from any external power supply source. | 0 | 0.1 | V | |
| V_{DDA} | Analog supply voltage | 2.7 | 5.5 | V | 4 |
| $V_{DD} - V_{DDA}$ | V_{DD} -to- V_{DDA} differential voltage | -0.1 | 0.1 | V | |
| V_{REFH} | ADC reference voltage high | 2.7 | $V_{DDA} + 0.1$ | V | 5 |
| V_{REFL} | ADC reference voltage low | -0.1 | 0.1 | V | |
| V_{ODPU} | Open drain pullup voltage level | V_{DD} | V_{DD} | V | 6 |
| $I_{INJPAD_DC_OP}^7$ | Continuous DC input current (positive / negative) that can be injected into an I/O pin | -3 | +3 | mA | |
| $I_{INJSUM_DC_OP}$ | Continuous total DC input current that can be injected across all I/O pins such that there's no degradation in accuracy of analog modules: ADC and ACMP (See section Analog Modules) | — | 30 | mA | |

- Typical conditions assumes $V_{DD} = V_{DDA} = V_{REFH} = 5$ V, temperature = 25 °C and typical silicon process unless otherwise stated.
- As V_{DD} varies between the minimum value and the absolute maximum value the analog characteristics of the I/O and the ADC will both change. See section [I/O parameters](#) and [ADC electrical specifications](#) respectively for details.
- S32K148 will operate from 2.7 V when executing from internal FIRC. When the PLL is engaged S32K148 is guaranteed to operate from 2.97 V. All other S32K family devices operate from 2.7 V in all modes.
- V_{DD} and V_{DDA} must be shorted to a common source on PCB. Appropriate decoupling capacitors to be used to filter noise on the supplies. See application note [AN5032](#) for reference supply design for SAR ADC.
- V_{REFH} should always be equal to or less than $V_{DDA} + 0.1$ V and $V_{DD} + 0.1$ V
- Open drain outputs must be pulled to V_{DD} .
- When input pad voltage levels are close to V_{DD} or V_{SS} , practically no current injection is possible.

4.3 Thermal operating characteristics

Table 3. Thermal operating characteristics for 64 LQFP, 100 LQFP, and 100 MAP-BGA packages.

| Symbol | Parameter | Value | | | Unit |
|--------------------|---------------------------------|-------|------|------------------|------|
| | | Min. | Typ. | Max. | |
| T_A C-Grade Part | Ambient temperature under bias | -40 | — | 85 ¹ | °C |
| T_J C-Grade Part | Junction temperature under bias | -40 | — | 105 ¹ | °C |
| T_A V-Grade Part | Ambient temperature under bias | -40 | — | 105 ¹ | °C |
| T_J V-Grade Part | Junction temperature under bias | -40 | — | 125 ¹ | °C |
| T_A M-Grade Part | Ambient temperature under bias | -40 | — | 125 ² | °C |
| T_J M-Grade Part | Junction temperature under bias | -40 | — | 135 ² | °C |

1. Values mentioned are measured at ≤ 112 MHz in HSRUN mode.
2. Values mentioned are measured at ≤ 80 MHz in RUN mode.

4.4 Power and ground pins

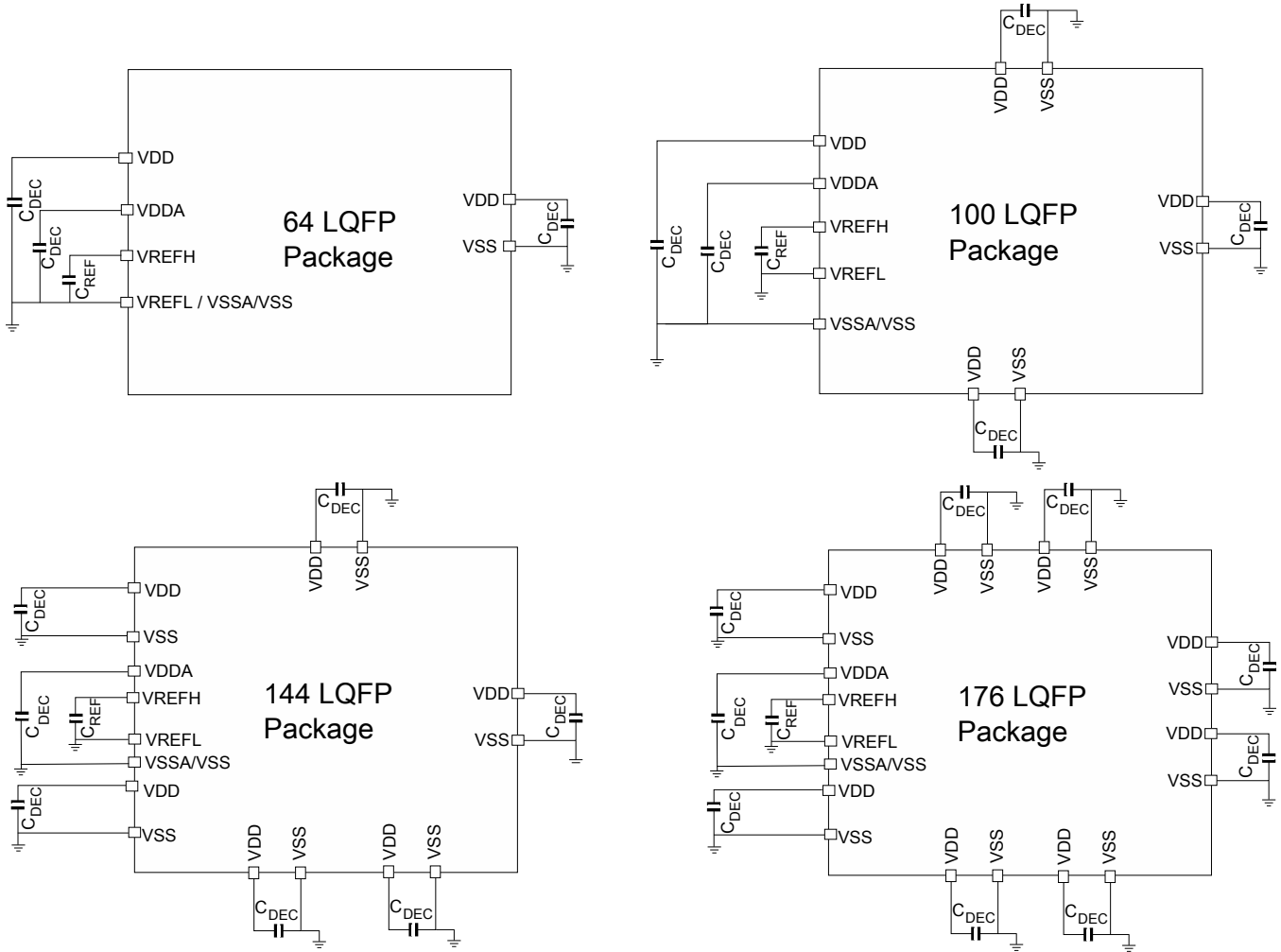

Figure 5. Pinout decoupling

Table 4. Supplies decoupling capacitors 1, 2

| Symbol | Description | Min. ³ | Typ. | Max. | Unit |
|---------------------|---|-------------------|------|------|------|
| $C_{REF}^{4, 5}$ | ADC reference high decoupling capacitance | 70 | 100 | — | nF |
| $C_{DEC}^{5, 6, 7}$ | Recommended decoupling capacitance | 70 | 100 | — | nF |

- V_{DD} and V_{DDA} must be shorted to a common source on PCB. Appropriate decoupling capacitors to be used to filter noise on the supplies. See application note AN5032 for reference supply design for SAR ADC. All V_{SS} pins should be connected to common ground at the PCB level.
- All decoupling capacitors must be low ESR ceramic capacitors (for example X7R type).
- Minimum recommendation is after considering component aging and tolerance.
- For improved performance, it is recommended to use 10 μ F, 0.1 μ F and 1 nF capacitors in parallel.
- All decoupling capacitors should be placed as close as possible to the corresponding supply and ground pins.
- Contact your local Field Applications Engineer for details on best analog routing practices.
- The filtering used for decoupling the device supplies must comply with the following best practices rules:
 - The protection/decoupling capacitors must be on the path of the trace connected to that component.

- No trace exceeding 1 mm from the protection to the trace or to the ground.
- The protection/decoupling capacitors must be as close as possible to the input pin of the device (maximum 2 mm).
- The ground of the protection is connected as short as possible to the ground plane under the integrated circuit.

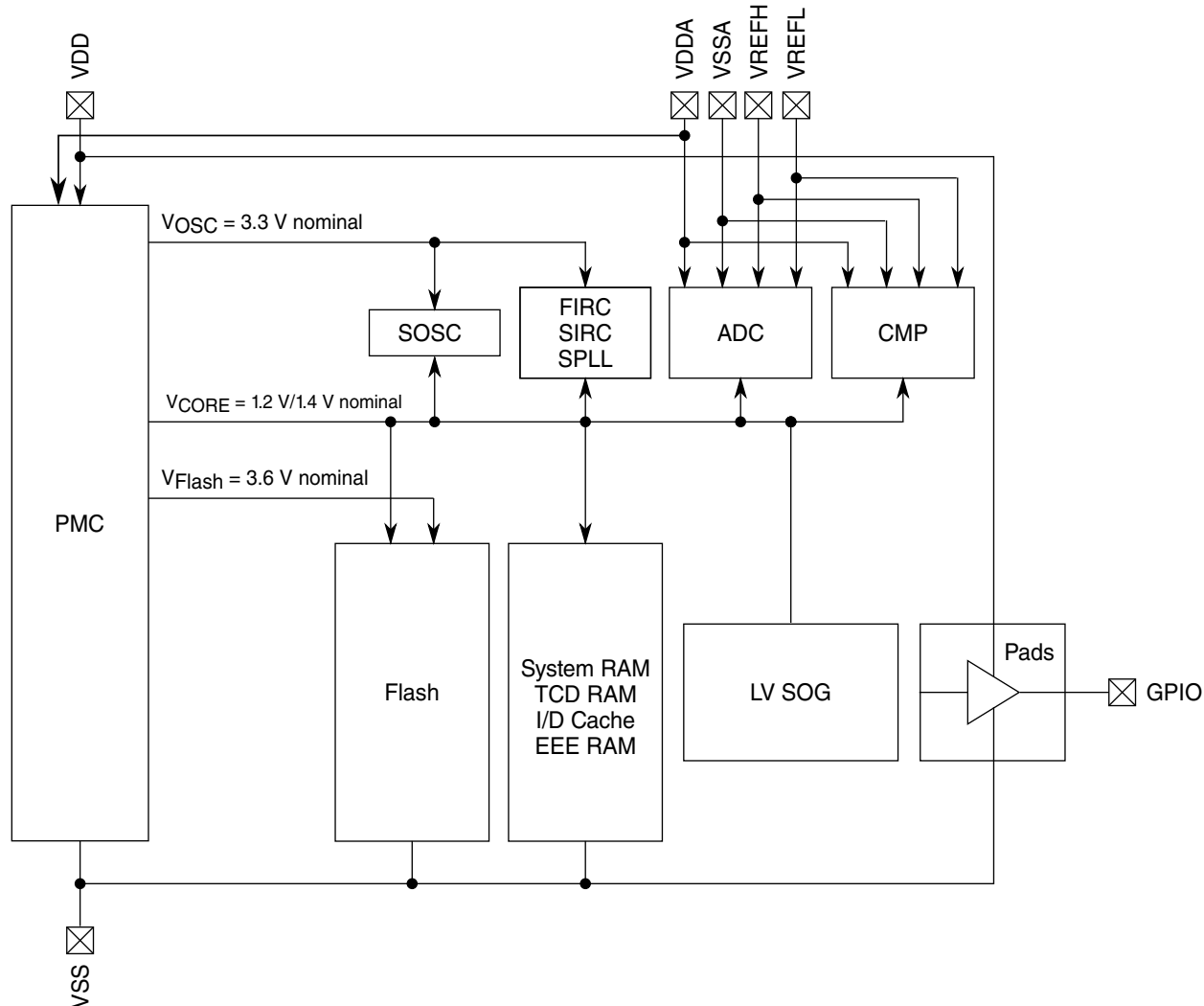

*Note: VSSA and VSS are shorted at package level

Figure 6. Power diagram

4.5 LVR, LVD and POR operating requirements

Table 5. V_{DD} supply LVR, LVD and POR operating requirements

| Symbol | Description | Min. | Typ. | Max. | Unit | Notes |
|-----------------------|---|------|------|------|------|-------|
| V _{POR} | Rising and falling V _{DD} POR detect voltage | 1.1 | 1.6 | 2.0 | V | |
| V _{LVR} | LVR falling threshold (RUN, HSRUN, and STOP modes) | 2.50 | 2.58 | 2.7 | V | |
| V _{LVR_HYST} | LVR hysteresis | — | 45 | — | mV | 1 |
| V _{LVR_LP} | LVR falling threshold (VLPS/VLPR modes) | 1.97 | 2.22 | 2.44 | V | |

Table continues on the next page...

Table 5. V_{DD} supply LVR, LVD and POR operating requirements (continued)

| Symbol | Description | Min. | Typ. | Max. | Unit | Notes |
|-----------------------|---------------------------------------|------|-------|------|------|-------|
| V _{LVD} | Falling low-voltage detect threshold | 2.8 | 2.875 | 3 | V | |
| V _{LVD_HYST} | LVD hysteresis | — | 50 | — | mV | 1 |
| V _{LVW} | Falling low-voltage warning threshold | 4.19 | 4.305 | 4.5 | V | |
| V _{LVW_HYST} | LVW hysteresis | — | 75 | — | mV | 1 |
| V _{BG} | Bandgap voltage reference | 0.97 | 1.00 | 1.03 | V | |

1. Rising threshold is the sum of falling threshold and hysteresis voltage.

4.6 Power mode transition operating behaviors

All specifications in the following table assume this clock configuration:

- RUN Mode:
 - Clock source: FIRC
 - SYS_CLK/CORE_CLK = 48 MHz
 - BUS_CLK = 48 MHz
 - FLASH_CLK = 24 MHz
- HSRUN Mode:
 - Clock source: SPLL
 - SYS_CLK/CORE_CLK = 112 MHz
 - BUS_CLK = 56 MHz
 - FLASH_CLK = 28 MHz
- VLPR Mode:
 - Clock source: SIRC
 - SYS_CLK/CORE_CLK = 4 MHz
 - BUS_CLK = 4 MHz
 - FLASH_CLK = 1 MHz
- STOP1/STOP2 Mode:
 - Clock source: FIRC
 - SYS_CLK/CORE_CLK = 48 MHz
 - BUS_CLK = 48 MHz
 - FLASH_CLK = 24 MHz
- VLPS Mode: All clock sources disabled.

Table 6. Power mode transition operating behaviors

| Symbol | Description | Min. | Typ. | Max. | Unit |
|------------------|--|------|------|------|------|
| t _{POR} | After a POR event, amount of time from the point V _{DD} reaches 2.7 V to execution of the first instruction across the operating temperature range of the chip. | — | 325 | — | μs |

Table continues on the next page...

Table 6. Power mode transition operating behaviors (continued)

| Symbol | Description | Min. | Typ. | Max. | Unit |
|--------|---------------------------------|------|-------|-------|------|
| | VLPS → RUN | 8 | — | 17 | μs |
| | STOP1 → RUN | 0.07 | 0.075 | 0.08 | μs |
| | STOP2 → RUN | 0.07 | 0.075 | 0.08 | μs |
| | VLPR → RUN | 19 | — | 26 | μs |
| | VLPR → VLPS | 5.75 | 6.25 | 6.5 | μs |
| | VLPS → VLPR | 26.5 | 27.25 | 27.75 | μs |
| | RUN → Compute operation | 0.35 | 0.38 | 0.4 | μs |
| | HSRUN → Compute operation | 0.3 | 0.31 | 0.35 | μs |
| | RUN → STOP1 | 0.35 | 0.38 | 0.4 | μs |
| | RUN → STOP2 | 0.2 | 0.23 | 0.25 | μs |
| | RUN → VLPS | 0.35 | 0.38 | 0.4 | μs |
| | RUN → VLPR | 4.4 | 4.7 | 5 | μs |
| | VLPS → Asynchronous DMA Wakeup | 105 | 110 | 125 | μs |
| | STOP1 → Asynchronous DMA Wakeup | 1 | 1.1 | 1.3 | μs |
| | STOP2 → Asynchronous DMA Wakeup | 1 | 1.1 | 1.3 | μs |
| | Pin reset → Code execution | — | 214 | — | μs |

NOTE

HSRUN should only be used when frequencies in excess of 80 MHz are required. When using 80 MHz and below, RUN mode is the recommended operating mode.

4.7 Power consumption

The following table shows the power consumption targets for the device in various mode of operations.

Table 7. Power consumption (Typicals unless stated otherwise) 1

| Ambient Temperature (°C) | | VLPS (µA) ^{2,3} | | VLPR (mA) | | STOP1 (mA) | STOP2 (mA) | RUN@48 MHz (mA) | | RUN@64 MHz (mA) | | RUN@80 MHz (mA) | | | |
|--------------------------|---------|-----------------------------------|---------------------|----------------------|---------------------|------------|------------|----------------------|---------------------|----------------------|---------------------|----------------------|---------------------|----------------------|-----|
| | | Peripherals disabled ⁶ | Peripherals enabled | Peripherals disabled | Peripherals enabled | | | Peripherals disabled | Peripherals enabled | Peripherals disabled | Peripherals enabled | Peripherals disabled | Peripherals enabled | Peripherals disabled | |
| 25 | S32K116 | Typ | 26 | 38 | 1.9 | 2.5 | 7 | 12 | TBD | TBD | TBD | TBD | TBD | TBD | |
| | | 105 | Typ | TBD | TBD | TBD | TBD | TBD | TBD | TBD | TBD | TBD | TBD | TBD | TBD |
| | | | Max | TBD | TBD | TBD | TBD | TBD | TBD | TBD | TBD | TBD | TBD | TBD | TBD |
| | | 125 | Max | TBD | TBD | TBD | TBD | TBD | TBD | TBD | TBD | TBD | TBD | TBD | 40 |
| 25 | S32K118 | Typ | 26 | 38 | 1.9 | 2.5 | 7 | 12 | TBD | TBD | TBD | TBD | TBD | TBD | |
| | | 105 | Typ | TBD | TBD | TBD | TBD | TBD | TBD | TBD | TBD | TBD | TBD | TBD | TBD |
| | | | Max | TBD | TBD | TBD | TBD | TBD | TBD | TBD | TBD | TBD | TBD | TBD | TBD |
| | | 125 | Max | TBD | TBD | TBD | TBD | TBD | TBD | TBD | TBD | TBD | TBD | TBD | 42 |
| 25 | S32K142 | Typ | 29 | 42 | 1.9 | 2.5 | 10 | 15 | TBD | TBD | TBD | TBD | TBD | TBD | |
| | | 105 | Typ | TBD | TBD | TBD | TBD | TBD | TBD | TBD | TBD | TBD | TBD | TBD | TBD |
| | | | Max | TBD | TBD | TBD | TBD | TBD | TBD | TBD | TBD | TBD | TBD | TBD | TBD |
| | | 125 | Max | TBD | TBD | TBD | TBD | TBD | TBD | TBD | TBD | TBD | TBD | TBD | TBD |
| 25 | S32K144 | Typ | 29.8 | 39.1 | 1.48 | 1.50 | 7 | 7.7 | 19.7 | 26.9 | 25.1 | 33.3 | 30.2 | 39.6 | |
| | | | | | | | | | | | | | | | |

Table continues on the next page...

Table 7. Power consumption (Typicals unless stated otherwise) 1 (continued)

| Ambient Temperature (°C) | VLPS (µA) ^{2,3} | | VLPR (mA) | STOP1 (mA) | STOP2 (mA) | RUN@48 MHz (mA) | | RUN@64 MHz (mA) | | RUN@80 MHz (mA) | | | |
|--------------------------|--------------------------|------|-----------|------------|------------|-----------------|------|-----------------|------|-----------------|------|------|------|
| | Typ | Max | | | | 20.4 | 27.1 | 26.1 | 33.5 | 30.5 | 40 | | |
| 85 | Typ | 150 | 1.72 | 1.85 | 7.2 | 8.1 | 20.4 | 27.1 | 26.1 | 33.5 | 30.5 | 40 | |
| | Max | 359 | 2.60 | 2.65 | 8.3 | 9.2 | 21.9 | 28.5 | 27.8 | 34.4 | 32.9 | 41.5 | |
| | 105 | Typ | 256 | 1.80 | 2.10 | 7.8 | 8.5 | 20.6 | 27.4 | 26.6 | 33.8 | 31.2 | 40.5 |
| Max | | 850 | 2.65 | 2.70 | 10.3 | 10.6 | 22.7 | 30 | 28.3 | 36.5 | 33.4 | 43.3 | |
| 125 | Max | 1960 | 3.18 | 3.25 | 12.2 | 13 | 25.3 | 32.7 | 35 | 39.8 | 37.1 | 46.5 | |
| | S32K146 | Typ | 40 | 5 | 6 | 15 | 20 | TBD | TBD | TBD | TBD | TBD | TBD |
| | | Typ | TBD | TBD | TBD | TBD | TBD | TBD | TBD | TBD | TBD | TBD | TBD |
| Max | | TBD | TBD | TBD | TBD | TBD | TBD | TBD | TBD | TBD | TBD | TBD | |
| 125 | Max | TBD | TBD | TBD | TBD | TBD | TBD | TBD | TBD | TBD | 70 | 80 | |
| | S32K148 ^{7,8} | Typ | 40 | 5 | 6 | 15 | 20 | TBD | TBD | TBD | TBD | TBD | TBD |
| | | Typ | TBD | TBD | TBD | TBD | TBD | TBD | TBD | TBD | TBD | TBD | TBD |
| Max | | TBD | TBD | TBD | TBD | TBD | TBD | TBD | TBD | TBD | TBD | TBD | |
| 125 | Max | TBD | TBD | TBD | TBD | TBD | TBD | TBD | TBD | TBD | 100 | 110 | |

1. Typical current numbers are indicative for typical silicon process and may vary based on the silicon distribution and user configuration.
2. This is an average based on the use case described in the Comparator section, whereby the analog sampling is taking place periodically enable the DAC as required. The numbers quoted assumes that only a single ANLCMP is active and the others are disabled
3. Current numbers are for reduced configuration and may vary based on user configuration and silicon process variation.
4. HSRUN mode must not be used at 125°C. Max ambient temperature for HSRUN mode is 105°C.
5. Values mentioned are measured at 25 °C at RUN@80 MHz with peripherals disabled.
6. With PMC_REGSC[CLKBIASDIS] set to 1. See Reference Manual for details.
7. Above S32K148 data is preliminary targets only
8. The S32K148 data points assume that ENET/QuadSPI/SAI etc. are active. If the same configuration is selected as per the S32K144, the very similar IDD.

4.7.1 Modes configuration

Attached *S32K1xx_Power_Modes_Configuration.xlsx* details the modes used in gathering the power consumption data stated in the above table [Table 7](#). For full functionality refer to table: Module operation in available low power modes of the *Reference Manual*.

4.8 ESD handling ratings

| Symbol | Description | Min. | Max. | Unit | Notes |
|------------------|---|--------|------|------|-------|
| V _{HBM} | Electrostatic discharge voltage, human body model | - 4000 | 4000 | V | 1 |
| V _{CDM} | Electrostatic discharge voltage, charged-device model | | | | 2 |
| | All pins except the corner pins | - 500 | 500 | V | |
| | Corner pins only | - 750 | 750 | V | |
| I _{LAT} | Latch-up current at ambient temperature of 125 °C | - 100 | 100 | mA | 3 |

1. Determined according to JEDEC Standard JESD22-A114, *Electrostatic Discharge (ESD) Sensitivity Testing Human Body Model (HBM)*.
2. Determined according to JEDEC Standard JESD22-C101, *Field-Induced Charged-Device Model Test Method for Electrostatic-Discharge-Withstand Thresholds of Microelectronic Components*.
3. Determined according to JEDEC Standard JESD78, *IC Latch-Up Test*.

4.9 EMC radiated emissions operating behaviors

EMC measurements to IC-level IEC standards are available from NXP on request.

5 I/O parameters

5.1 AC electrical characteristics

Unless otherwise specified, propagation delays are measured from the 50% to the 50% point, and rise and fall times are measured at the 20% and 80% points, as shown in the following figure.

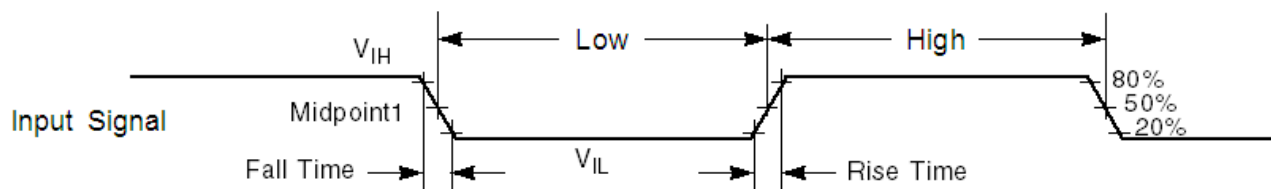

The midpoint is $V_{IL} + (V_{IH} - V_{IL})/2$.

Figure 7. Input signal measurement reference

5.2 General AC specifications

These general purpose specifications apply to all signals configured for GPIO, UART, and timers.

Table 8. General switching specifications

| Symbol | Description | Min. | Max. | Unit | Notes |
|--------|--|------|------|------------------|-------|
| | GPIO pin interrupt pulse width (digital glitch filter disabled) — Synchronous path | 1.5 | — | Bus clock cycles | 1, 2 |
| | GPIO pin interrupt pulse width (digital glitch filter disabled, passive filter disabled) — Asynchronous path | 50 | — | ns | 3 |
| WFRST | RESET input filtered pulse | — | 100 | ns | 4 |
| WFRST | RESET input not filtered pulse | 100 | — | ns | |

1. This is the minimum pulse width that is guaranteed to pass through the pin synchronization circuitry. Shorter pulses may or may not be recognized. In Stop and VLPS modes, the synchronizer is bypassed so shorter pulses can be recognized in that case.
2. The greater of synchronous and asynchronous timing must be met.
3. These pins do not have a passive filter on the inputs. This is the shortest pulse width that is guaranteed to be recognized.
4. Minimum length of $\overline{\text{RESET}}$ pulse, guaranteed not to be filtered by the internal filter.

5.3 DC electrical specifications at 3.3 V Range

Table 9. DC electrical specifications at 3.3 V Range

| Symbol | Parameter | Value | | | Unit | Notes |
|--------------|---|----------------------|------|---------------------|------|-------|
| | | Min. | Typ. | Max. | | |
| V_{DD} | I/O Supply Voltage | 2.7 | 3.3 | 4 | V | 1 |
| V_{ih} | Input Buffer High Voltage | $0.7 \times V_{DD}$ | — | $V_{DD} + 0.3$ | V | 2 |
| V_{il} | Input Buffer Low Voltage | $V_{SS} - 0.3$ | — | $0.3 \times V_{DD}$ | V | 3 |
| V_{hys} | Input Buffer Hysteresis | $0.06 \times V_{DD}$ | — | — | V | |
| Ioh_Standard | I/O current source capability measured when pad = $(V_{DDE} - 0.8 \text{ V})$ | 3.5 | — | — | mA | |

Table continues on the next page...

Table 9. DC electrical specifications at 3.3 V Range (continued)

| Symbol | Parameter | Value | | | Unit | Notes |
|-----------------|---|-------|-------|------|------|-------|
| | | Min. | Typ. | Max. | | |
| Iol_Standard | I/O current sink capability measured when pad = 0.8 V | 3 | — | — | mA | |
| Ioh_Strong | I/O current source capability measured when pad = (V _{DDE} - 0.8 V) | 14 | — | — | mA | 4 |
| Iol_Strong | I/O current sink capability measured when pad = 0.8 V | 12 | — | — | mA | 5 |
| IOHT | Output high current total for all ports | — | — | 100 | mA | |
| IIN | Input leakage current (per pin) for full temperature range at V _{DD} = 3.3 V | | | | | 6 |
| | All pins other than high drive port pins | | 0.005 | 0.5 | μA | |
| | High drive port pins ⁷ | | 0.010 | 0.5 | μA | |
| R _{PU} | Internal pullup resistors | 20 | | 60 | kΩ | 8 |
| R _{PD} | Internal pulldown resistors | 20 | | 60 | kΩ | 9 |

- S32K148 will operate from 2.7 V when executing from internal FIRC. When the PLL is engaged S32K148 is guaranteed to operate from 2.97 V. All other S32K family devices operate from 2.7 V in all modes.
- For reset pads, same V_{ih} levels are applicable
- For reset pads, same V_{il} levels are applicable
- The value given is measured at high drive strength mode. For value at low drive strength mode see the Ioh_Standard value given above.
- The value given is measured at high drive strength mode. For value at low drive strength mode see the Iol_Standard value given above.
- Several I/O have both high drive and normal drive capability selected by the associated Portx_PCRn[DSE] control bit. All other GPIOs are normal drive only. For details refer to *S32K144_IO_Signal_Description_Input_Multiplexing.xlsx* attached with the *Reference Manual*.
- When using ENET and SAI on S32K148, the overall device limits associated with high drive pin configurations must be respected i.e. On 144-pin LQFP the general purpose pins: PTA10, PTD0, and PTE4 must be set to low drive.
- Measured at input V = V_{SS}
- Measured at input V = V_{DD}

5.4 DC electrical specifications at 5.0 V Range

Table 10. DC electrical specifications at 5.0 V Range

| Symbol | Parameter | Value | | | Unit | Notes |
|------------------|--|------------------------|------|------------------------|------|-------|
| | | Min. | Typ. | Max. | | |
| V _{DD} | I/O Supply Voltage | 4 | — | 5.5 | V | |
| V _{ih} | Input Buffer High Voltage | 0.65 x V _{DD} | — | V _{DD} + 0.3 | V | 1 |
| V _{il} | Input Buffer Low Voltage | V _{SS} - 0.3 | — | 0.35 x V _{DD} | V | 2 |
| V _{hys} | Input Buffer Hysteresis | 0.06 x V _{DD} | — | — | V | |
| Ioh_Standard | I/O current source capability measured when pad = (V _{DDE} - 0.8 V) | 5 | — | — | mA | |
| Iol_Standard | I/O current sink capability measured when pad = 0.8 V | 5 | — | — | mA | |

Table continues on the next page...

Table 10. DC electrical specifications at 5.0 V Range (continued)

| Symbol | Parameter | Value | | | Unit | Notes |
|-----------------|---|-------|-------|------|---------------|-------|
| | | Min. | Typ. | Max. | | |
| Ioh_Strong | I/O current source capability measured when pad = $V_{DDE} - 0.8\text{ V}$ | 20 | — | — | mA | 3, 4 |
| Iol_Strong | I/O current sink capability measured when pad = 0.8 V | 20 | — | — | mA | 4, 5 |
| IOHT | Output high current total for all ports | — | — | 100 | mA | |
| IIN | Input leakage current (per pin) for full temperature range at $V_{DD} = 5.5\text{ V}$ | | | | | 6 |
| | All pins other than high drive port pins | | 0.005 | 0.5 | μA | |
| | High drive port pins | | 0.010 | 0.5 | μA | |
| R _{PU} | Internal pullup resistors | 20 | | 50 | k Ω | 7 |
| R _{PD} | Internal pulldown resistors | 20 | | 50 | k Ω | 8 |

- For reset pads, same V_{ih} levels are applicable
- For reset pads, same V_{il} levels are applicable
- The value given is measured at high drive strength mode. For value at low drive strength mode see the Ioh_Standard value given above.
- The strong pad I/O pin is capable of switching a 50 pF load at up to 40 MHz.
- The value given is measured at high drive strength mode. For value at low drive strength mode see the Iol_Standard value given above.
- Several I/O have both high drive and normal drive capability selected by the associated Portx_PCRn[DSE] control bit. All other GPIOs are normal drive only. For details refer to *SK3K144_IO_Signal_Description_Input_Multiplexing.xlsx* attached with the *Reference Manual*.
- Measured at input $V = V_{SS}$
- Measured at input $V = V_{DD}$

5.5 AC electrical specifications at 3.3 V range

Table 11. AC electrical specifications at 3.3 V Range

| Symbol | DSE | Rise time (nS) ¹ | | Fall time (nS) ¹ | | Capacitance (pF) ² |
|----------|-----|-----------------------------|------|-----------------------------|------|-------------------------------|
| | | Min. | Max. | Min. | Max. | |
| Standard | NA | 4.6 | 14.5 | 3.9 | 15.7 | 25 |
| | | 7.2 | 23.7 | 6.2 | 26.2 | 50 |
| | | 24.0 | 75.4 | 20.8 | 88.4 | 200 |
| Strong | 0 | 4.6 | 14.5 | 3.9 | 15.7 | 25 |
| | | 7.2 | 23.7 | 6.2 | 26.2 | 50 |
| | | 24.0 | 75.4 | 20.8 | 88.4 | 200 |
| | 1 | 2.0 | 5.8 | 1.8 | 6.1 | 25 |
| | | 2.8 | 8.0 | 2.6 | 8.3 | 50 |
| | | 7.0 | 20.7 | 6.0 | 22.4 | 200 |

- For reference only. Run simulations with the IBIS model and your custom board for accurate results.
- Maximum capacitances supported on Standard IOs. However interface or protocol specific specifications might be different, for example for ENET, QSPI etc. . For protocol specific AC specifications, see respective sections.

5.6 AC electrical specifications at 5 V range

Table 12. AC electrical specifications at 5 V Range

| Symbol | DSE | Rise time (nS) ¹ | | Fall time (nS) ¹ | | Capacitance (pF) ² |
|----------|-----|-----------------------------|-------|-----------------------------|------|-------------------------------|
| | | Min. | Max . | Min. | Max. | |
| Standard | NA | 3.2 | 9.4 | 3.6 | 10.7 | 25 |
| | | 5.4 | 15.7 | 5.1 | 17.4 | 50 |
| | | 18.5 | 52.6 | 17.6 | 59.7 | 200 |
| Strong | 0 | 4.0 | 9.4 | 3.6 | 10.7 | 25 |
| | | 5.8 | 15.7 | 5.1 | 17.4 | 50 |
| | | 18.1 | 52.6 | 17.6 | 59.7 | 200 |
| | 1 | 1.6 | 4.6 | 1.5 | 5.0 | 25 |
| | | 2.2 | 5.7 | 2.2 | 5.8 | 50 |
| | | 5.6 | 14.6 | 5.0 | 15.4 | 200 |

1. For reference only. Run simulations with the IBIS model and your custom board for accurate results.
2. Maximum capacitances supported on Standard IOs. However interface or protocol specific specifications might be different, for example for ENET, QSPI etc. . For protocol specific AC specifications, see respective sections.

5.7 Standard input pin capacitance

Table 13. Standard input pin capacitance

| Symbol | Description | Min. | Max. | Unit |
|-------------------|---------------------------------|------|------|------|
| C _{IN_D} | Input capacitance: digital pins | — | 7 | pF |

NOTE

Please refer to [External System Oscillator electrical specifications](#) for EXTAL/XTAL pins.

5.8 Device clock specifications

Table 14. Device clock specifications 1

| Symbol | Description | Min. | Max. | Unit |
|----------------------------------|-----------------------|------|------|------|
| High Speed run mode ² | | | | |
| f _{sys} | System and core clock | — | 112 | MHz |
| f _{bus} | Bus clock | — | 56 | MHz |
| f _{flash} | Flash clock | — | 28 | MHz |
| Normal run mode (S32K11x series) | | | | |

Table continues on the next page...

Table 14. Device clock specifications 1 (continued)

| Symbol | Description | Min. | Max. | Unit |
|---|--------------------------|------|-------|------|
| f_{SYS} | System and core clock | — | 48 | MHz |
| f_{BUS} | Bus clock | — | 24 | MHz |
| f_{FLASH} | Flash clock | — | 24 | MHz |
| Normal run mode (S32K14x series) ³ | | | | |
| f_{SYS} | System and core clock | — | 80 | MHz |
| f_{BUS} | Bus clock | — | 40 | MHz |
| f_{FLASH} | Flash clock | — | 26.67 | MHz |
| VLPR mode ⁴ | | | | |
| f_{SYS} | System and core clock | — | 4 | MHz |
| f_{BUS} | Bus clock | — | 4 | MHz |
| f_{FLASH} | Flash clock | — | 1 | MHz |
| f_{ERCLK} | External reference clock | — | 16 | MHz |

1. Refer to the section [Feature comparison](#) for the availability of modes and other specifications.
2. Only available on some devices. See section [Feature comparison](#).
3. With SPLL as system clock source.
4. The frequency limitations in VLPR mode here override any frequency specification listed in the timing specification for any other module.

6 Peripheral operating requirements and behaviors

6.1 System modules

There are no electrical specifications necessary for the device's system modules.

6.2 Clock interface modules

6.2.1 External System Oscillator electrical specifications

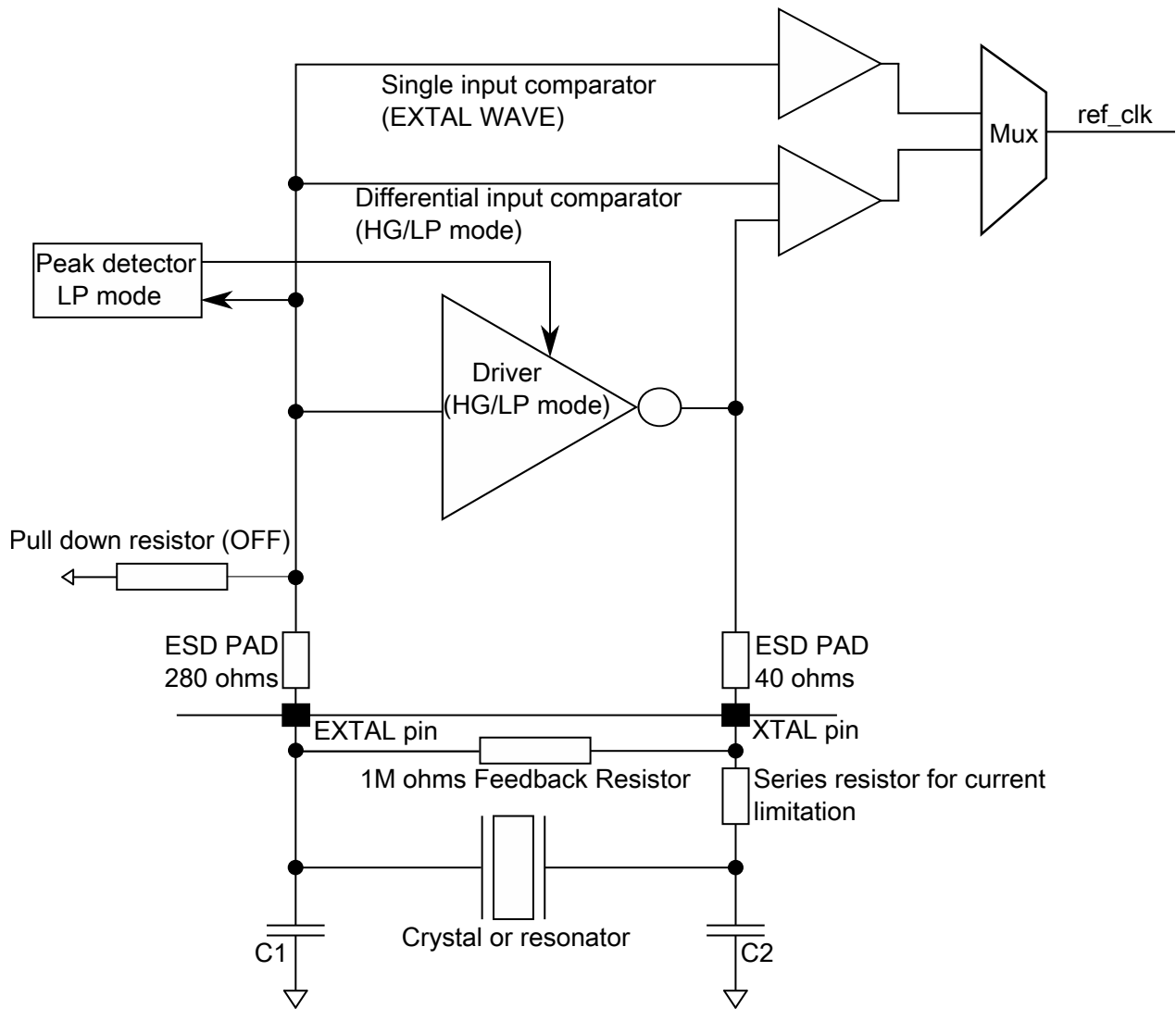

Figure 8. Oscillator connections scheme

Table 15. External System Oscillator electrical specifications

| Symbol | Description | Min. | Typ. | Max. | Unit | Notes |
|--------------------|---|-----------------------|------|------------------------|------|-------|
| g _{mXOSC} | Crystal oscillator transconductance | | | | | |
| | 4-8 MHz | 2.2 | — | 13.7 | mA/V | |
| | 8-40 MHz | 16 | — | 47 | mA/V | |
| V _{IL} | Input low voltage — EXTAL pin in external clock mode | V _{SS} | — | 0.35 * V _{DD} | V | |
| V _{IH} | Input high voltage — EXTAL pin in external clock mode | 0.7 * V _{DD} | — | V _{DD} | V | |
| C ₁ | EXTAL load capacitance | — | — | — | | 1 |
| C ₂ | XTAL load capacitance | — | — | — | | 1 |
| R _F | Feedback resistor | | | | | 2 |
| | Low-gain mode (HGO=0) | — | — | — | MΩ | |

Table continues on the next page...

Table 15. External System Oscillator electrical specifications (continued)

| Symbol | Description | Min. | Typ. | Max. | Unit | Notes |
|-----------------|---|------|------|------|------|-------|
| | High-gain mode (HGO=1) | — | 1 | — | MΩ | |
| R _S | Series resistor | | | | | |
| | Low-gain mode (HGO=0) | — | 0 | — | kΩ | |
| | High-gain mode (HGO=1) | — | 0 | — | kΩ | |
| V _{pp} | Peak-to-peak amplitude of oscillation (oscillator mode) | | | | | 3 |
| | Low-gain mode (HGO=0) | — | 1.0 | — | V | |
| | High-gain mode (HGO=1) | — | 3.3 | — | V | |

1. Crystal oscillator circuit provides stable oscillations when $g_{mXOSC} > 5 * gm_crit$. The gm_crit is defined as:

$$gm_crit = 4 * ESR * (2\pi F)^2 * (C_0 + C_L)^2$$

where:

- g_{mXOSC} is the transconductance of the internal oscillator circuit
- ESR is the equivalent series resistance of the external crystal
- F is the external crystal oscillation frequency
- C_0 is the shunt capacitance of the external crystal
- C_L is the external crystal total load capacitance. $C_L = C_s + [C_1 * C_2 / (C_1 + C_2)]$
- C_s is stray or parasitic capacitance on the pin due to any PCB traces
- C_1, C_2 external load capacitances on EXTAL and XTAL pins

See manufacture datasheet for external crystal component values

2. • When low-gain is selected, internal R_F will be selected and external R_F should not be attached.
• When high-gain is selected, external R_F (1 M Ohm) needs to be connected for proper operation of the crystal. For external resistor, up to 5% tolerance is allowed.
3. The EXTAL and XTAL pins should only be connected to required oscillator components and must not be connected to any other devices.

6.2.2 External System Oscillator frequency specifications

Table 16. External System Oscillator frequency specifications

| Symbol | Description | Min. | Typ. | Max. | Unit | Notes |
|-----------------------|--|------|------|------|------|-------|
| f _{osc_hi} | Oscillator crystal or resonator frequency | 4 | — | 40 | MHz | |
| f _{ec_extal} | Input clock frequency (external clock mode) | — | — | 50 | MHz | |
| t _{dc_extal} | Input clock duty cycle (external clock mode) | 40 | 50 | 60 | % | |
| t _{cst} | Crystal Start-up Time | | | | | 1 |
| | 8 MHz low-gain mode (HGO=0) | — | 1.5 | — | ms | |
| | 8 MHz high-gain mode (HGO=1) | — | 2.5 | — | | |
| | 40 MHz low-gain mode (HGO=0) | — | 2 | — | | |
| | 40 MHz high-gain mode (HGO=1) | — | 2 | — | | |

1. Proper PC board layout procedures must be followed to achieve specifications.

6.2.3 System Clock Generation (SCG) specifications

6.2.3.1 Fast internal RC Oscillator (FIRC) electrical specifications

Table 17. Fast internal RC Oscillator electrical specifications

| Symbol | Parameter ¹ | Value | | | Unit |
|-------------------------------|--|-------|------|------|--------------------|
| | | Min. | Typ. | Max. | |
| F _{FIRC} | FIRC target frequency | — | 48 | — | MHz |
| ΔF | Frequency deviation across process, voltage, and temperature < 105°C | — | ±0.5 | ±1 | %F _{FIRC} |
| ΔF125 | Frequency deviation across process, voltage, and temperature < 125°C | — | ±0.5 | ±1.1 | %F _{FIRC} |
| T _{Startup} | Startup time | | 3.4 | 5 | μs ² |
| T _{JIT} ³ | Cycle-to-Cycle jitter | — | 250 | 500 | ps |
| T _{JIT} ³ | Long term jitter over 1000 cycles | — | 0.04 | 0.1 | %F _{FIRC} |

1. With FIRC regulator enable
2. Startup time is defined as the time between clock enablement and clock availability for system use.
3. FIRC as system clock

NOTE

Fast internal RC Oscillator is compliant with CAN and LIN standards.

6.2.3.2 Slow internal RC oscillator (SIRC) electrical specifications

Table 18. Slow internal RC oscillator (SIRC) electrical specifications

| Symbol | Parameter | Value | | | Unit |
|----------------------|--|-------|------|------|--------------------|
| | | Min. | Typ. | Max. | |
| F _{SIRC} | SIRC target frequency | — | 8 | — | MHz |
| ΔF | Frequency deviation across process, voltage, and temperature < 105°C | — | — | ±3 | %F _{SIRC} |
| ΔF125 | Frequency deviation across process, voltage, and temperature < 125°C | — | — | ±3.3 | %F _{SIRC} |
| T _{Startup} | Startup time | — | 9 | 12.5 | μs ¹ |

1. Startup time is defined as the time between clock enablement and clock availability for system use.

6.2.4 Low Power Oscillator (LPO) electrical specifications

Table 19. Low Power Oscillator (LPO) electrical specifications

| Symbol | Parameter | Min. | Typ. | Max. | Unit |
|----------------------|---|------|------|------|------|
| F _{LPO} | Internal low power oscillator frequency | 113 | 128 | 139 | kHz |
| T _{startup} | Startup Time | — | — | 20 | μs |

6.2.5 SPLL electrical specifications

Table 20. SPLL electrical specifications

| Symbol | Parameter | Min. | Typ. | Max. | Unit |
|--------------------------------------|--|--------|------|--|------|
| F _{SPLL_REF} ¹ | PLL Reference Frequency Range | 8 | — | 16 | MHz |
| F _{SPLL_Input} ² | PLL Input Frequency | 8 | — | 40 | MHz |
| F _{VCO_CLK} | VCO output frequency | 180 | — | 320 | MHz |
| F _{SPLL_CLK} | PLL output frequency | 90 | — | 160 | MHz |
| J _{CYC_SPLL} | PLL Period Jitter (RMS) ³ | | | | |
| | at F _{VCO_CLK} 180 MHz | — | 120 | — | ps |
| | at F _{VCO_CLK} 320 MHz | — | 75 | — | ps |
| J _{ACC_SPLL} | PLL accumulated jitter over 1μs (RMS) ³ | | | | |
| | at F _{VCO_CLK} 180 MHz | — | 1350 | — | ps |
| | at F _{VCO_CLK} 320 MHz | — | 600 | — | ps |
| D _{UNL} | Lock exit frequency tolerance | ± 4.47 | — | ± 5.97 | % |
| T _{SPLL_LOCK} | Lock detector detection time ⁴ | — | — | 150 × 10 ⁻⁶ + 1075(1/F _{SPLL_REF}) | s |

1. F_{SPLL_REF} is PLL reference frequency range after the PREDIV. For PREDIV and MULT settings refer SCG_SPLL_CFG register of Reference Manual.
2. F_{SPLL_Input} is PLL input frequency range before the PREDIV must be limited to the range 8 MHz to 40 MHz. This input source could be derived from a crystal oscillator or some other external square wave clock source using OSC bypass mode. For external clock source settings refer SCG_SOSCCFG register of Reference Manual.
3. This specification was obtained using a NXP developed PCB. PLL jitter is dependent on the noise characteristics of each PCB and results will vary
4. Lock detector detection time is defined as the time between PLL enablement and clock availability for system use.

6.3 Memory and memory interfaces

6.3.1 Flash memory module (FTFC) electrical specifications

This section describes the electrical characteristics of the flash memory module.

6.3.1.1 Flash timing specifications — commands

Table 21. Flash command timing specifications

| Symbol | Description ¹ | Min. | Typ. | Max. | Unit | Notes |
|------------------|---|------|------|------|---------|-------|
| $t_{rd1blk64k}$ | Read 1s Block execution time | — | — | 0.5 | ms | |
| $t_{rd1blk512k}$ | • 64 KB data flash • 512 KB program flash | — | — | 1.8 | ms | |
| $t_{rd1sec2k}$ | Read 1s Section execution time (2 KB flash) | — | — | 75 | μ s | |
| $t_{rd1sec4k}$ | Read 1s Section execution time (4 KB flash) | — | — | 100 | μ s | |
| t_{pgmchk} | Program Check execution time | — | — | 95 | μ s | |
| t_{pgm8} | Program Phrase execution time | — | 90 | 150 | μ s | |
| $t_{ersblk64k}$ | Erase Flash Block execution time | — | 55 | 475 | ms | 2 |
| $t_{ersblk512k}$ | • 64 KB data flash • 512 KB program flash | — | 435 | 3700 | ms | |
| t_{ersscr} | Erase Flash Sector execution time | — | 15 | 115 | ms | 2 |
| $t_{pgmsec1k}$ | Program Section execution time (1KB flash) | — | 5 | — | ms | |
| $t_{rd1allx}$ | Read 1s All Blocks execution time | — | — | 2.2 | ms | |
| | | — | — | 4.4 | ms | |
| | | — | — | 6.6 | ms | |
| t_{rdonce} | Read Once execution time | — | — | 30 | μ s | |
| $t_{pgmonce}$ | Program Once execution time | — | 90 | — | μ s | |
| t_{ersall} | Erase All Blocks execution time | — | 500 | 4200 | ms | 2 |
| t_{vfykey} | Verify Backdoor Access Key execution time | — | — | 35 | μ s | |
| $t_{ersallu}$ | Erase All Blocks Unsecure execution time | — | 500 | 4200 | ms | 2 |
| $t_{pgmpart32k}$ | Program Partition for EEPROM execution time | — | 70 | — | ms | 3, 4 |
| $t_{pgmpart64k}$ | • 32 KB EEPROM backup • 64 KB EEPROM backup (Non-Interleaved DFlash) • 64 KB EEPROM backup (Interleaved DFlash) | — | 71 | — | ms | |
| | | — | 250 | — | ms | |
| $t_{setramff}$ | Set FlexRAM Function execution time: | — | 70 | — | μ s | 3, 4 |
| $t_{setram32k}$ | • Control Code 0xFF • 32 KB EEPROM backup | — | 0.8 | 1.2 | ms | |
| $t_{setram48k}$ | • 48 KB EEPROM backup | — | 1.0 | 1.5 | ms | |
| $t_{setram64k}$ | • 64 KB EEPROM backup | — | 1.3 | 1.9 | ms | |
| $t_{eewr8b32k}$ | Byte-write to FlexRAM execution time: | — | 385 | 1700 | μ s | 3, 4 |
| $t_{eewr8b48k}$ | • 32 KB EEPROM backup • 48 KB EEPROM backup | — | 430 | 1850 | μ s | |
| $t_{eewr8b64k}$ | • 64 KB EEPROM backup | — | 475 | 2000 | μ s | |
| $t_{eewr16b32k}$ | 16-bit write to FlexRAM execution time: | — | 385 | 1700 | μ s | 3, 4 |
| $t_{eewr16b48k}$ | • 32 KB EEPROM backup | — | 430 | 1850 | μ s | |

Table continues on the next page...

Table 21. Flash command timing specifications (continued)

| Symbol | Description ¹ | Min. | Typ. | Max. | Unit | Notes |
|---------------------------|---|------|------|--------------------------------|------|-------|
| t _{eevr16b64k} | <ul style="list-style-type: none"> 48 KB EEPROM backup 64 KB EEPROM backup | — | 475 | 2000 | μs | |
| t _{eevr32bers} | 32-bit write to erased FlexRAM location execution time | — | 360 | 2000 | μs | |
| t _{eevr32b32k} | 32-bit write to FlexRAM execution time: | — | 630 | 2000 | μs | 3, 4 |
| t _{eevr32b48k} | <ul style="list-style-type: none"> 32 KB EEPROM backup | — | 720 | 2125 | μs | |
| t _{eevr32b64k} | <ul style="list-style-type: none"> 48 KB EEPROM backup 64 KB EEPROM backup | — | 810 | 2250 | μs | |
| t _{quickwr} | 32-bit Quick Write execution time : Time from CCIF clearing (start the write) until CCIF setting (32-bit write complete, ready for next 32-bit write) | | | | | |
| | <ul style="list-style-type: none"> 1st 32-bit write | — | 200 | 550 | μs | 5, 6 |
| | <ul style="list-style-type: none"> 2nd through Next to Last (Nth-1) 32-bit write | — | 150 | 550 | μs | |
| | <ul style="list-style-type: none"> Last (Nth) 32-bit write (time for write only, not cleanup) | — | 200 | 550 | μs | |
| t _{quickwrCInup} | Quick Write Cleanup execution time | — | — | (Number of Quick Writes) * 2.0 | ms | 7 |

- All command times assumes 25 MHz or greater flash clock frequency (for synchronization time between internal/external clocks).
- Maximum times for erase parameters based on expectations at cycling end-of-life.
- For all EEPROM Emulation terms, the specified timing shown assumes previous record clean up has occurred. This may be verified by executing FCCOB Command 0x77, and checking FCCOB number 5 contents show 0x00 - No EEPROM issues detected.
- 'First time' EERAM writes after a Reset or SETRAM may incur additional overhead for EEE cleanup, resulting in up to 2x the times shown.
- For 'Typ.', only after the Nth write completes will any data will be valid. Emulated EEPROM record scheme cleanup overhead may occur after this point even after a brownout or reset. If power or reset occurs before the Nth write completes, the last valid record set will still be valid and the new records will be discarded.
- Quick Write may take up to 550 μs as additional cleanup may occur when crossing sector boundaries.
- Time for emulated EEPROM record scheme overhead cleanup. Automatically done after last (Nth) write completes, assuming still powered. Or via SETRAM cleanup execution command is requested at a later point.

NOTE

Under certain circumstances FlexMEM maximum times may be exceeded. In this case the user or application may wait, or assert reset to the FTFC macro to stop the operation.

6.3.1.2 Reliability specifications**Table 22. NVM reliability specifications**

| Symbol | Description | Min. | Typ. | Max. | Unit | Notes |
|--------------------------------------|-------------|------|------|------|------|-------|
| When using as Program and Data Flash | | | | | | |

Table continues on the next page...

Table 22. NVM reliability specifications (continued)

| Symbol | Description | Min. | Typ. | Max. | Unit | Notes |
|---|---|-------|------|------|--------|---------|
| $t_{nvmretp1k}$ | Data retention after up to 1 K cycles | 20 | — | — | years | |
| $n_{nvmcycp}$ | Cycling endurance | 1 K | — | — | cycles | 2, 1 |
| When using FlexMemory feature: FlexRAM as Emulated EEPROM | | | | | | |
| $t_{nvmretee}$ | Data retention | 5 | — | — | years | |
| $n_{nvmwree16}$ | Write endurance | 100 K | — | — | writes | 3, 4, 5 |
| $n_{nvmwree256}$ | <ul style="list-style-type: none"> EEPROM backup to FlexRAM ratio = 16 EEPROM backup to FlexRAM ratio = 256 | 1.6 M | — | — | writes | |

1. Program and Erase for PFlash and DFlash are supported across product temperature specification in Normal Mode (not supported in HSRUN mode).
2. Cycling endurance is per DFlash or PFlash Sector.
3. FlexMemory write endurance specified for 16-bit and/or 32-bit writes to FlexRAM and is supported across standard temperature specification in Normal Mode (not supported in HSRUN mode). Greater write endurance may be achieved with larger ratios of EEPROM backup to FlexRAM.
4. For usage of any other EEE driver other than the FlexMemory feature, the endurance specification will fall back to the specified endurance value of the D-Flash specification (1 K).
5. [EEE calculator tool](#) is available at NXP web site to help estimate the maximum write endurance achievable at specific EEPROM/FlexRAM ratio. The "In Spec" portions of the online calculator refer to the NVM reliability specifications section of data sheet. This calculator is only applies to the FlexMemory feature.

6.3.2 QuadSPI AC specifications

The following table describes the QuadSPI electrical characteristics.

- Measurements are with maximum output load of 25 pF, input transition of 1 ns and pad configured with fastest slew settings (DSE = 1'b1).
- I/O operating voltage ranges from 2.97 V to 3.6 V
- While doing the mode transition (RUN -> HSRUN or HSRUN -> RUN), the interface should be OFF.
- Add 50 ohm series termination on board in QuadSPI SCK for Flash A to avoid loop back reflection when using in Internal DQS (PAD Loopback) mode.
- For non-Quad mode of operation if external device doesn't have pull-up feature, external pull-up needs to be added at board level for non-used pads.
- With external pull-up, performance of the interface may degrade based on load associated with external pull-up.

Table 23. QuadSPI electrical specifications

| FLASH PORT | Sym | Unit | FLASH A | | | | | | | | | | | | | | | |
|---------------------|------------------|------|--------------------|------|--------------------|--------------|--------------------|------|--------------------|------|--------------------|--------------|--------------------|------|--------------------|------|--------------------|------|
| | | | RUN ¹ | | | | | | HSRUN ¹ | | | | | | | | | |
| | | | SDR | | | | | | SDR | | | | | | | | | |
| | | | Internal Sampling | | | Internal DQS | | | Internal Sampling | | | Internal DQS | | | | | | |
| N1 | | Min | PAD Loopback | | Max | N1 | | Min | PAD Loopback | | Max | N1 | | Min | PAD Loopback | | Max | |
| Register Settings | | | | | | | | | | | | | | | | | | |
| MCR[DDR_EN] | | - | 0 | 0 | 0 | 0 | 0 | 0 | 0 | 0 | 0 | 0 | 0 | 0 | 0 | 0 | 0 | 0 |
| MCR[DQS_EN] | | - | 0 | 1 | 1 | 1 | 0 | 0 | 0 | 1 | 1 | 0 | 1 | 1 | 0 | 1 | 1 | 0 |
| MCR[SCLKCFG[0]] | | - | - | 1 | 1 | 0 | 0 | - | - | 1 | 1 | 0 | 1 | 1 | 0 | 1 | 1 | 0 |
| MCR[SCLKCFG[1]] | | - | - | 1 | 1 | 0 | 0 | - | - | 1 | 1 | 0 | 1 | 1 | 0 | 1 | 1 | 0 |
| MCR[SCLKCFG[2]] | | - | - | - | - | - | - | - | - | - | - | - | - | - | - | - | - | - |
| MCR[SCLKCFG[3]] | | - | - | - | - | - | - | - | - | - | - | - | - | - | - | - | - | - |
| MCR[SCLKCFG[5]] | | - | - | - | - | - | - | - | - | - | - | - | - | - | - | - | - | - |
| SMPR[FSPHS] | | - | 0 | 1 | 0 | 0 | 0 | 0 | 0 | 1 | 1 | 0 | 1 | 1 | 0 | 1 | 1 | 0 |
| SMPR[FSPLY] | | - | 0 | 0 | 0 | 0 | 0 | 0 | 0 | 0 | 0 | 0 | 0 | 0 | 0 | 0 | 0 | 0 |
| SOCCR | | - | - | 0 | 23 | 23 | - | - | - | 0 | 0 | 30 | 30 | - | - | 0 | 0 | 30 |
| [SOCCFG[7:0]] | | - | - | - | - | - | - | - | - | - | - | - | - | - | - | - | - | - |
| SOCCR[SOCCFG[15:8]] | | - | - | - | - | - | - | - | - | - | - | - | - | - | - | - | - | - |
| FLSHCR[TDH] | | - | 0x00 | 0x00 | 0x00 | 0x00 | 0x00 | 0x00 | 0x00 | 0x00 | 0x00 | 0x00 | 0x00 | 0x00 | 0x00 | 0x00 | 0x00 | 0x00 |
| Timing Parameters | | | | | | | | | | | | | | | | | | |
| SCK Clock Frequency | f _{sck} | MHz | - | 38 | - | 48 | - | 40 | - | 80 | - | 50 | - | 50 | - | 50 | - | 50 |
| SCK Clock Period | t _{sck} | ns | 1/f _{sck} | - | 1/f _{sck} | - | 1/f _{sck} | - | 1/f _{sck} | - | 1/f _{sck} | - | 1/f _{sck} | - | 1/f _{sck} | - | 1/f _{sck} | - |

Table continues on the next page...

Table 23. QuadSPI electrical specifications (continued)

| FLASH PORT | Sym | Unit | FLASH A | | | | | | | | | | | | | |
|-----------------------------|--------------------|------|-------------------------|-------------------------|-------------------------|-------------------------|-------------------------|-------------------------|-------------------------|-------------------------|-------------------------|-------------------------|-------------------------|-------------------------|-------------------------|-------------------------|
| | | | RUN ¹ | | | | | | HSRUN ¹ | | | | | | | |
| | | | Internal Sampling | | | Internal DQS | | | Internal Sampling | | | Internal DQS | | | | |
| QuadSPI Mode | | | N1 | | | PAD Loopback | | | N1 | | | PAD Loopback | | | | |
| | | | Min | Max | | Min | Max | | Min | Max | | Min | Max | | Min | Max |
| SCK Duty Cycle | t _{SDC} | ns | t _{SK/2 - 1.5} | t _{SK/2 + 1.5} | t _{SK/2 - 1.5} | t _{SK/2 - 1.5} | t _{SK/2 + 1.5} | t _{SK/2 - 1.5} | t _{SK/2 - 1.5} | t _{SK/2 - 1.5} | t _{SK/2 - 1.5} | t _{SK/2 - 1.5} | t _{SK/2 - 1.5} | t _{SK/2 - 1.5} | t _{SK/2 - 1.5} | t _{SK/2 - 2.5} |
| Data Input Setup Time | t _{IS} | ns | 15 | - | 2.5 | - | 10 | - | 14 | - | 1.5 | - | 9 | - | 25 | - |
| Data Input Hold Time | t _{IH} | ns | 0 | - | 1 | - | 1 | - | 0 | - | 1 | - | 1 | - | 0 | - |
| Data Output Valid Time | t _{OV} | ns | - | 4.5 | - | 4.5 | - | 4.5 | - | 4.5 | - | 4 | - | 4 | - | - |
| Data Output In-Valid Time | t _{IV} | ns | 5 | - | 5 | - | 5 | - | 5 | - | 3 ⁵ | - | 5 | - | 5 | - |
| CS to SCK Time ⁶ | t _{CSCK} | ns | 5 | - | 5 | - | 5 | - | 5 | - | 5 | - | 5 | - | 10 | - |
| SCK to CS Time ⁷ | t _{CSCKS} | ns | 5 | - | 5 | - | 5 | - | 5 | - | 5 | - | 5 | - | 5 | - |
| Output Load | | pf | 25 | | 25 | | 25 | | 25 | | 25 | | 25 | | 25 | |

1. See Reference Manual for details on mode settings
2. See Reference Manual for details on mode settings
3. Valid for HyperRAM only
4. RWDS(External DQS CLK) frequency
5. For operating frequency ≤ 64 Mhz, Output invalid time is 5 ns.
6. Program register value QuadSPI_FLASHCR[TCSS] = 4'h2
7. Program register value QuadSPI_FLASHCR[TCSH] = 4'h1

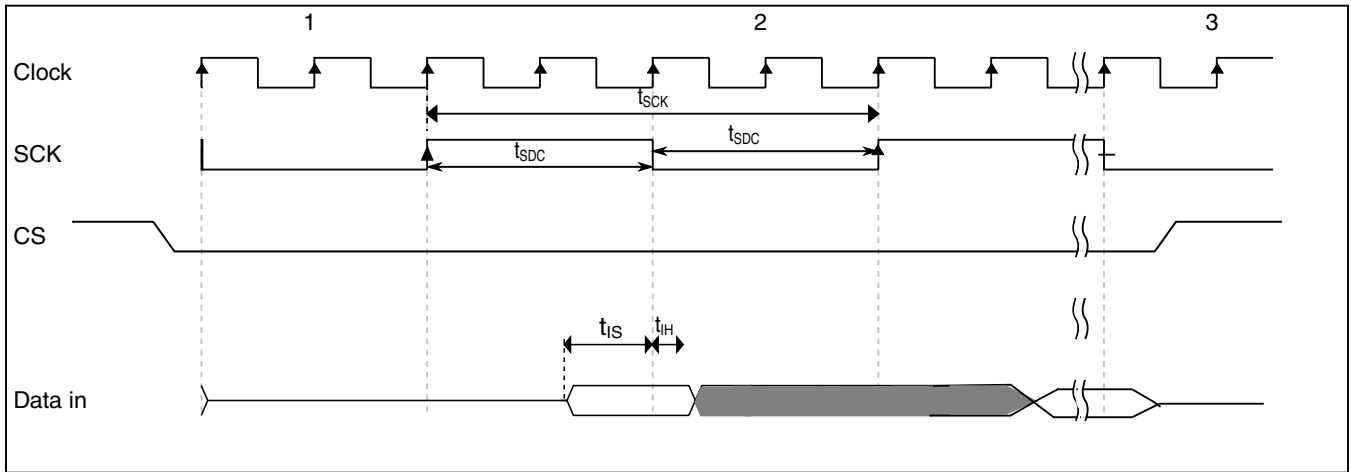

Figure 9. QuadSPI input timing (SDR mode) diagram

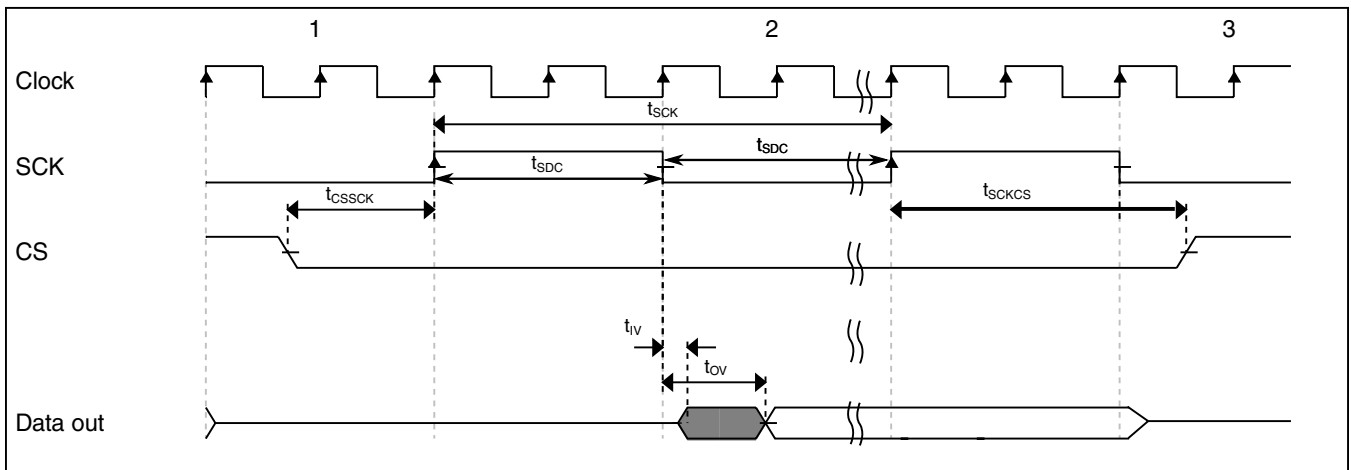

Figure 10. QuadSPI output timing (SDR mode) diagram

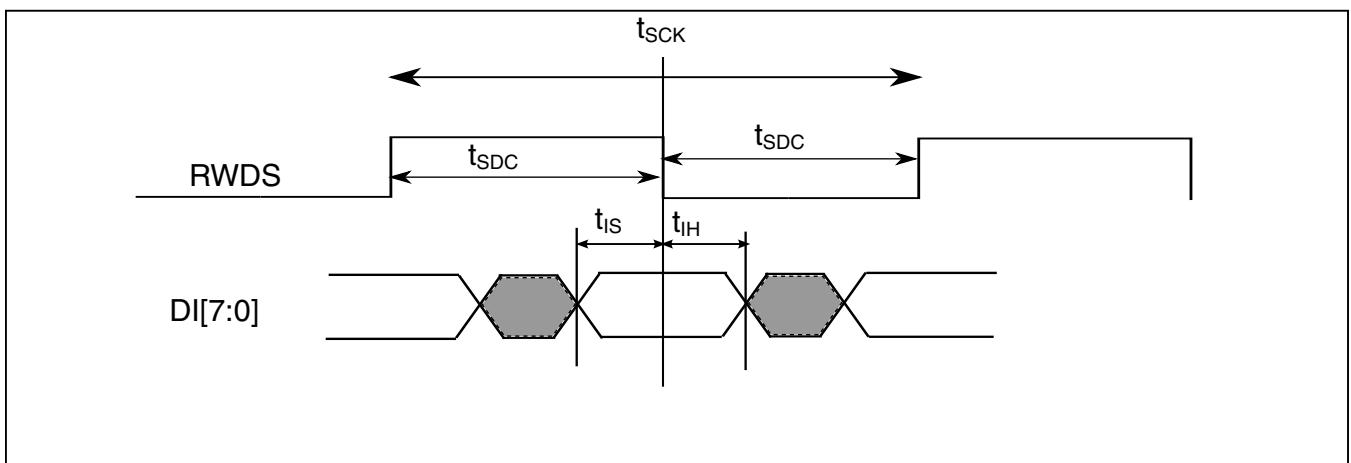

Figure 11. QuadSPI input timing (HyperRAM mode) diagram

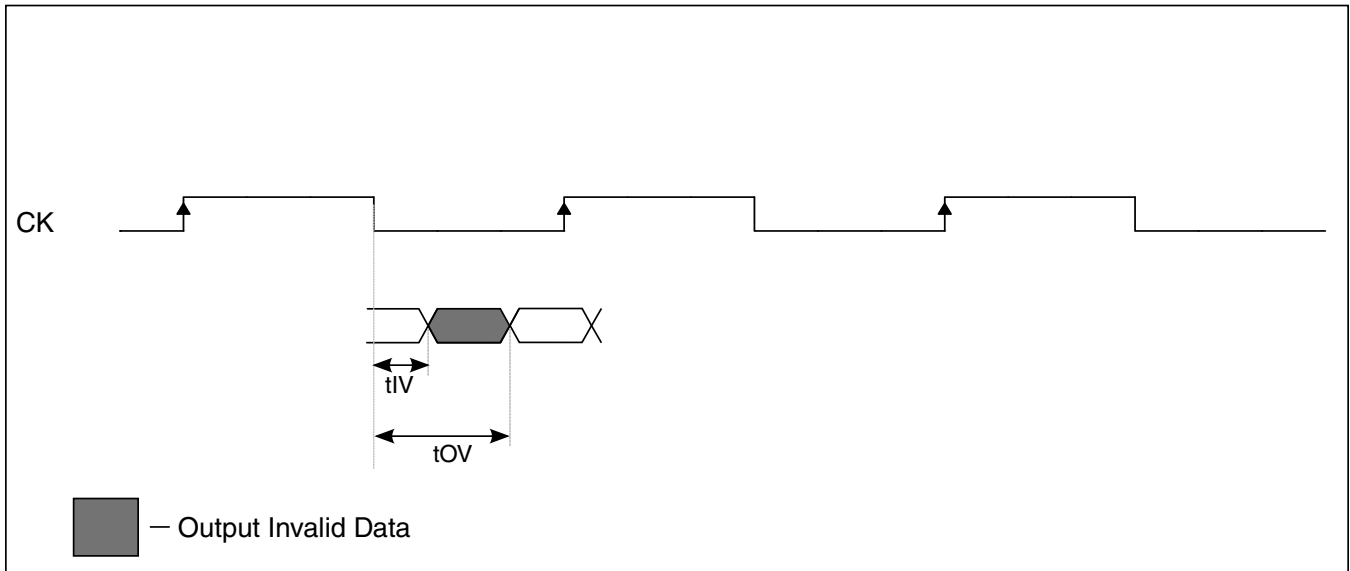

Figure 12. QuadSPI output timing (HyperRAM mode) diagram

6.4 Analog modules

6.4.1 ADC electrical specifications

6.4.1.1 12-bit ADC operating conditions

Table 24. 12-bit ADC operating conditions

| Symbol | Description | Conditions | Min. | Typ. ¹ | Max. | Unit | Notes |
|------------------|------------------------------------|--|---|-------------------|---|------------|-------|
| ΔV_{DDA} | Supply voltage | Delta to V_{DD} ($V_{DD} - V_{DDA}$) | -0.1 | 0 | +0.1 | V | 2 |
| V_{REFH} | ADC reference voltage high | | See Voltage and current operating requirements for values | V_{DDA} | See Voltage and current operating requirements for values | V | 3 |
| V_{REFL} | ADC reference voltage low | | See Voltage and current operating requirements for values | 0 | See Voltage and current operating requirements for values | mV | 3 |
| V_{ADIN} | Input voltage | | V_{REFL} | — | V_{REFH} | V | |
| R_S | Source impedence | $f_{ADCK} < 4$ MHz | — | — | 5 | k Ω | |
| R_{SW1} | Channel Selection Switch Impedance | | — | -0.75 | 1.2 | k Ω | |
| R_{AD} | Sampling Switch Impedance | | — | 2 | 5 | k Ω | |
| C_{P1} | Pin Capacitance | | — | 10 | — | pF | |

Table continues on the next page...

Table 24. 12-bit ADC operating conditions (continued)

| Symbol | Description | Conditions | Min. | Typ. ¹ | Max. | Unit | Notes |
|-------------------|--------------------------------|---|------|-------------------|-------|------|-------|
| C _{P2} | Analog Bus Capacitance | | — | — | 4 | pF | |
| C _S | Sampling capacitance | | — | 4 | 5 | pF | |
| f _{ADCK} | ADC conversion clock frequency | Normal usage | 2 | 40 | 50 | MHz | 4, 5 |
| f _{CONV} | ADC conversion frequency | No ADC hardware averaging. ⁶ Continuous conversions enabled, subsequent conversion time | 46.4 | 928 | 1160 | Ksps | 7, 8 |
| | | ADC hardware averaging set to 32. ⁶ Continuous conversions enabled, subsequent conversion time | 1.45 | 29 | 36.25 | Ksps | 7, 8 |

1. Typical values assume V_{DDA} = 5 V, Temp = 25 °C, f_{ADCK} = 40 MHz, R_{AS}=20 Ω, and C_{AS}=10 nF unless otherwise stated. Typical values are for reference only, and are not tested in production.
2. DC potential difference.
3. For packages without dedicated V_{REFH} and V_{REFL} pins, V_{REFH} is internally tied to V_{DDA}, and V_{REFL} is internally tied to V_{SS}. To get maximum performance, reference supply quality should be better than SAR ADC. See application note AN5032 for details.
4. Clock and compare cycle need to be set according to the guidelines mentioned in the *Reference Manual*.
5. ADC conversion will become less reliable above maximum frequency.
6. When using ADC hardware averaging, see the *Reference Manual* to determine the most appropriate setting for AVGS.
7. Numbers based on the minimum sampling time of 275 ns.
8. For guidelines and examples of conversion rate calculation, see the *Reference Manual* or download the ADC calculator tool.

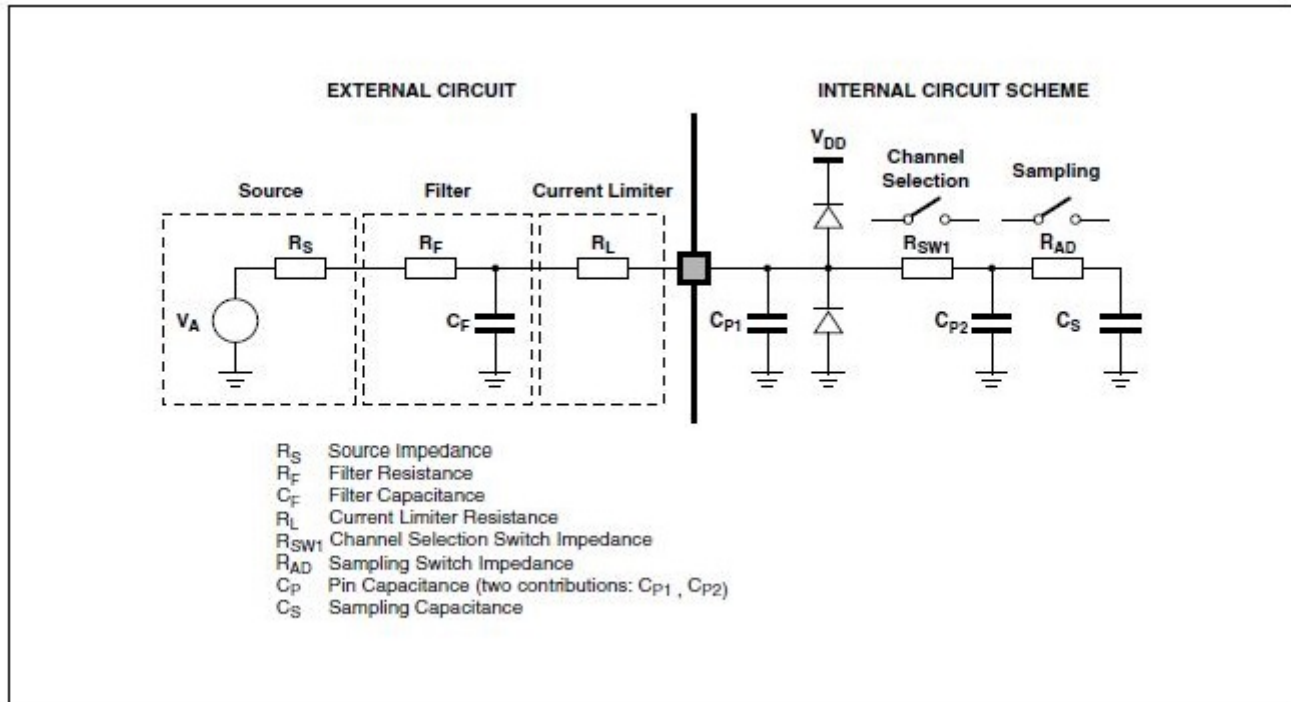

Figure 13. ADC input impedance equivalency diagram

6.4.1.2 12-bit ADC electrical characteristics

NOTE

ADC performance specifications are documented using a single ADC. For parallel/simultaneous operation of both ADCs, either for sampling the same channel by both ADCs or for sampling different channels by each ADC, some amount of decrease in performance can be expected. Care must be taken to stagger the two ADC conversions, in particular the sample phase, to minimize the impact of simultaneous conversions.

Table 25. 12-bit ADC characteristics (2.7 V to 3 V) ($V_{REFH} = V_{DDA}$, $V_{REFL} = V_{SS}$)

| Symbol | Description | Conditions ¹ | Min. | Typ. ² | Max. | Unit | Notes |
|------------------|----------------------------|-------------------------|------|-------------------|--------------------------------------|------------------|------------|
| V_{DDA} | Supply voltage | | 2.7 | — | 3 | V | |
| I_{DDA_ADC} | Supply current per ADC | | — | 0.6 | 1.5 | mA | 3 |
| SMPLTS | Sample Time | | 275 | — | Refer to the <i>Reference Manual</i> | ns | |
| TUE ⁴ | Total unadjusted error | | — | ±4 | ±8 | LSB ⁵ | 6, 7, 8, 9 |
| DNL | Differential non-linearity | | — | ±1.0 | — | LSB ⁵ | 6, 7, 8, 9 |
| INL | Integral non-linearity | | — | ±2.0 | — | LSB ⁵ | 6, 7, 8, 9 |

1. All accuracy numbers assume the ADC is calibrated with $V_{REFH}=V_{DDA}=V_{DD}$, with the calibration frequency set to half the ADC clock frequency.
2. Typical values assume $V_{DDA} = 3\text{ V}$, $\text{Temp} = 25\text{ }^\circ\text{C}$, $f_{ADCK} = 40\text{ MHz}$, $R_{AS}=20\text{ }\Omega$, and $C_{AS}=10\text{ nF}$, 100 LQFP package unless otherwise stated.
3. The ADC supply current depends on the ADC conversion rate.
4. Represents total static error, which includes offset and full scale error.
5. $1\text{ LSB} = (V_{REFH} - V_{REFL})/2^N$
6. The specifications are with averaging and in standalone mode only. Performance may degrade depending upon device use case scenario. When using ADC averaging, refer to the *Reference Manual* to determine the most appropriate settings for AVGS.
7. For ADC signals adjacent to V_{DD}/V_{SS} or XTAL/EXTAL or high frequency switching pins, some degradation in the ADC performance may be observed.
8. All values guarantee the performance of the ADC for multiple ADC input channel pins. When using ADC to monitor the internal analog parameters, assume minor degradation.
9. All the parameters in the table are given assuming system clock as the clocking source for ADC.

Table 26. 12-bit ADC characteristics (3 V to 5.5 V)($V_{REFH} = V_{DDA}$, $V_{REFL} = V_{SS}$)

| Symbol | Description | Conditions ¹ | Min. | Typ. ² | Max. | Unit | Notes |
|----------------|------------------------|-------------------------|------|-------------------|--------------------------------------|------|-------|
| V_{DDA} | Supply voltage | | 3 | — | 5.5 | V | |
| I_{DDA_ADC} | Supply current per ADC | | — | 1 | 2.1 | mA | 3 |
| SMPLTS | Sample Time | | 275 | — | Refer to the <i>Reference Manual</i> | ns | |

Table continues on the next page...

Table 26. 12-bit ADC characteristics (3 V to 5.5 V)($V_{REFH} = V_{DDA}$, $V_{REFL} = V_{SS}$) (continued)

| Symbol | Description | Conditions ¹ | Min. | Typ. ² | Max. | Unit | Notes |
|------------------|----------------------------|-------------------------|------|-------------------|------|------------------|------------|
| TUE ⁴ | Total unadjusted error | | — | ±4 | ±8 | LSB ⁵ | 6, 7, 8, 9 |
| DNL | Differential non-linearity | | — | ±0.7 | — | LSB ⁵ | 6, 7, 8, 9 |
| INL | Integral non-linearity | | — | ±1.0 | — | LSB ⁵ | 6, 7, 8, 9 |

- All accuracy numbers assume the ADC is calibrated with $V_{REFH}=V_{DDA}=V_{DD}$, with the calibration frequency set to half the ADC clock frequency.
- Typical values assume $V_{DDA} = 5.0$ V, Temp = 25 °C, $f_{ADCK} = 40$ MHz, $R_{AS}=20$ Ω, and $C_{AS}=10$ nF unless otherwise stated.
- The ADC supply current depends on the ADC conversion rate.
- Represents total static error, which includes offset and full scale error.
- 1 LSB = $(V_{REFH} - V_{REFL})/2^N$
- The specifications are with averaging and in standalone mode only. Performance may degrade depending upon device use case scenario. When using ADC averaging, refer to the *Reference Manual* to determine the most appropriate settings for AVGS.
- For ADC signals adjacent to V_{DD}/V_{SS} or XTAL/EXTAL or high frequency switching pins, some degradation in the ADC performance may be observed.
- All values guarantee the performance of the ADC for multiple ADC input channel pins. When using ADC to monitor the internal analog parameters, assume minor degradation.
- All the parameters in the table are given assuming system clock as the clocking source for ADC.

NOTE

When using high speed interfaces such as the QuadSPI, SAI0, SAI1 or ENET there may be some ADC degradation on the adjacent analog input paths. See following table for details.

| Pin name | TGATE purpose |
|----------|--------------------|
| PTE8 | CMP0_IN3 |
| PTC3 | ADC0_SE11/CMP0_IN4 |
| PTC2 | ADC0_SE10/CMP0_IN5 |
| PTD7 | CMP0_IN6 |
| PTD6 | CMP0_IN7 |
| PTD28 | ADC1_SE22 |
| PTD27 | ADC1_SE21 |

6.4.2 CMP with 8-bit DAC electrical specifications**Table 28. Comparator with 8-bit DAC electrical specifications**

| Symbol | Description | Min. | Typ. | Max. | Unit |
|-------------|--|------|------|------|------|
| I_{DDHS} | Supply current, High-speed mode ¹ | | | | μA |
| | -40 - 125 °C | — | 230 | 300 | |
| $I_{DDL S}$ | Supply current, Low-speed mode ¹ | | | | μA |
| | -40 - 105 °C | — | 5 | 10 | |
| | -40 - 125 °C | | 5 | 13 | |

Table continues on the next page...

Table 28. Comparator with 8-bit DAC electrical specifications (continued)

| Symbol | Description | Min. | Typ. | Max. | Unit |
|--------------------|---|------|----------------------|------------------|------|
| V _{AIN} | Analog input voltage | 0 | 0 - V _{DDA} | V _{DDA} | V |
| V _{AIO} | Analog input offset voltage, High-speed mode | | | | mV |
| | -40 - 125 °C | -25 | ±1 | 25 | |
| V _{AIO} | Analog input offset voltage, Low-speed mode | | | | mV |
| | -40 - 125 °C | -40 | ±4 | 40 | |
| t _{DHSB} | Propagation delay, High-speed mode ² | | | | ns |
| | -40 - 105 °C | — | 30 | 200 | |
| | -40 - 125 °C | | 30 | 300 | |
| t _{DLSB} | Propagation delay, Low-speed mode ² | | | | µs |
| | -40 - 105 °C | — | 0.5 | 2 | |
| | -40 - 125 °C | — | 0.5 | 3 | |
| t _{DHSS} | Propagation delay, High-speed mode ³ | | | | ns |
| | -40 - 105 °C | — | 70 | 400 | |
| | -40 - 125 °C | — | 70 | 500 | |
| t _{DLSS} | Propagation delay, Low-speed mode ³ | | | | µs |
| | -40 - 105 °C | — | 1 | 5 | |
| | -40 - 125 °C | — | 1 | 5 | |
| t _{IDHS} | Initialization delay, High-speed mode ⁴ | | | | µs |
| | -40 - 125 °C | — | 1.5 | 3 | |
| t _{IDLS} | Initialization delay, Low-speed mode ⁴ | | | | µs |
| | -40 - 125 °C | — | 10 | 30 | |
| V _{HYST0} | Analog comparator hysteresis, Hyst0 (V _{AIO}) | | | | mV |
| | -40 - 125 °C | — | 0 | — | |
| V _{HYST1} | Analog comparator hysteresis, Hyst1, High-speed mode | | | | mV |
| | -40 - 125 °C | — | 16 | 66 | |
| | Analog comparator hysteresis, Hyst1, Low-speed mode | | | | |
| | -40 - 125 °C | — | 11 | 40 | |
| V _{HYST2} | Analog comparator hysteresis, Hyst2, High-speed mode | | | | mV |
| | -40 - 125 °C | — | 32 | 133 | |
| | Analog comparator hysteresis, Hyst2, Low-speed mode | | | | |
| | -40 - 125 °C | — | 22 | 80 | |
| V _{HYST3} | Analog comparator hysteresis, Hyst3, High-speed mode | | | | mV |
| | -40 - 125 °C | — | 48 | 200 | |
| | Analog comparator hysteresis, Hyst3, Low-speed mode | | | | |
| | -40 - 125 °C | — | 33 | 120 | |

Table continues on the next page...

Table 28. Comparator with 8-bit DAC electrical specifications (continued)

| Symbol | Description | Min. | Typ. | Max. | Unit |
|--------------------|--|-------|------|------|------------------|
| I _{DAC8b} | 8-bit DAC current adder (enabled) | | | | |
| | 3.3V Reference Voltage | — | 6 | 9 | μA |
| | 5V Reference Voltage | — | 10 | 16 | μA |
| INL ⁵ | 8-bit DAC integral non-linearity | -0.75 | — | 0.75 | LSB ⁶ |
| DNL | 8-bit DAC differential non-linearity | -0.5 | — | 0.5 | LSB ⁶ |
| t _{DDAC} | Initialization and switching settling time | — | — | 30 | μs |

1. Difference at input > 200mV
2. Applied ± (100 mV + V_{HYST0/1/2/3}+ max. of V_{AIO}) around switch point.
3. Applied ± (30 mV + 2 × V_{HYST0/1/2/3}+ max. of V_{AIO}) around switch point.
4. Applied ± (100 mV + V_{HYST0/1/2/3}).
5. Calculation method used: Linear Regression Least Square Method
6. 1 LSB = V_{reference}/256

NOTE

For comparator IN signals adjacent to V_{DD}/V_{SS} or XTAL/EXTAL or switching pins cross coupling may happen and hence hysteresis settings can be used to obtain the desired comparator performance. Additionally, an external capacitor (1nF) should be used to filter noise on input signal. Also, source drive should not be weak (Signal with < 50 K pull up/down is recommended).

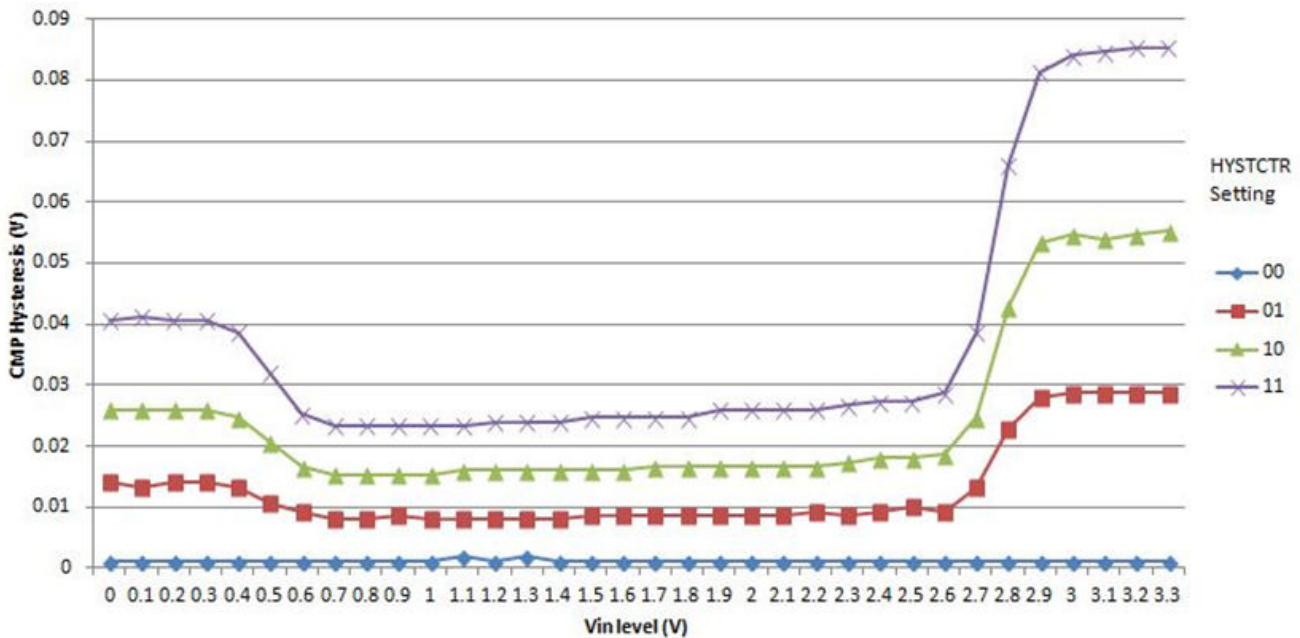

Figure 14. Typical hysteresis vs. Vin level (VDDA = 3.3 V, PMODE = 0)

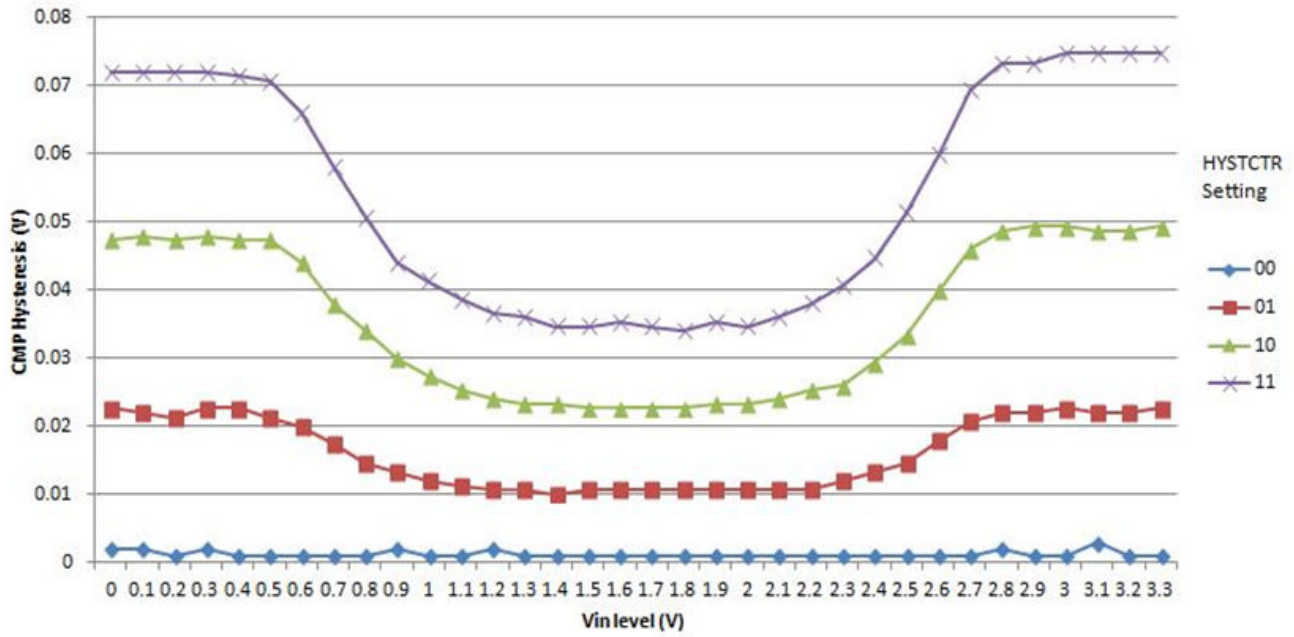

Figure 15. Typical hysteresis vs. Vin level (VDDA = 3.3 V, PMODE = 1)

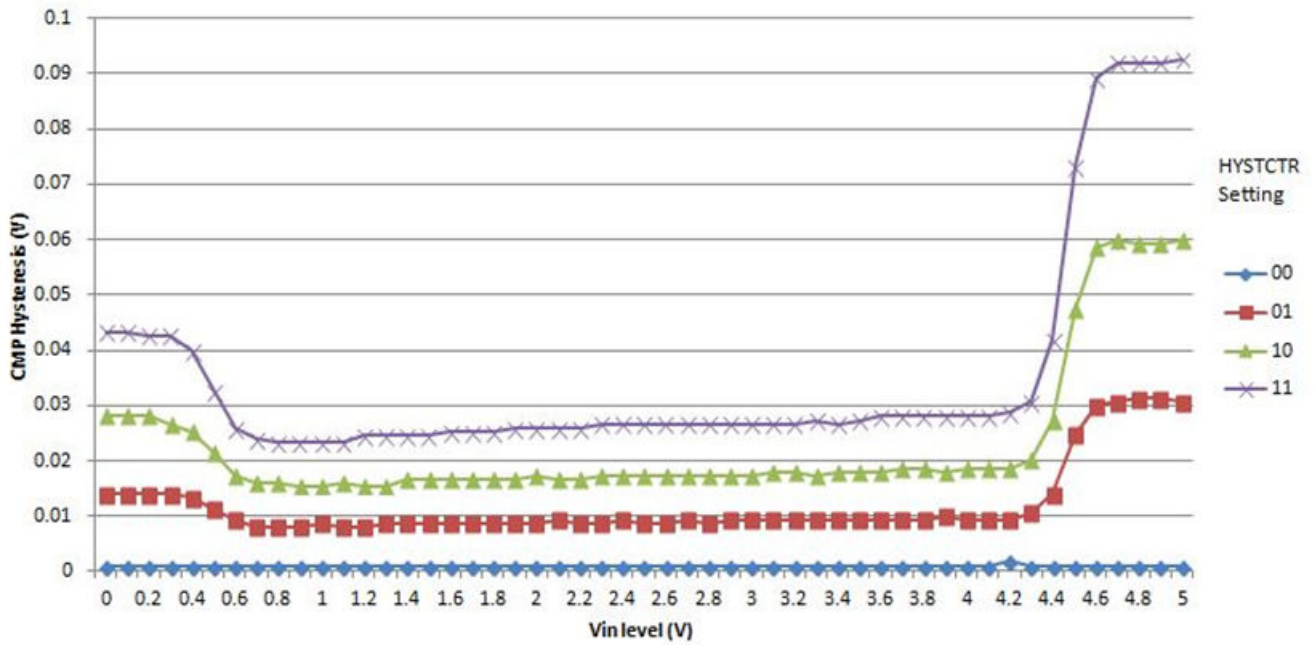

Figure 16. Typical hysteresis vs. Vin level (VDDA = 5 V, PMODE = 0)

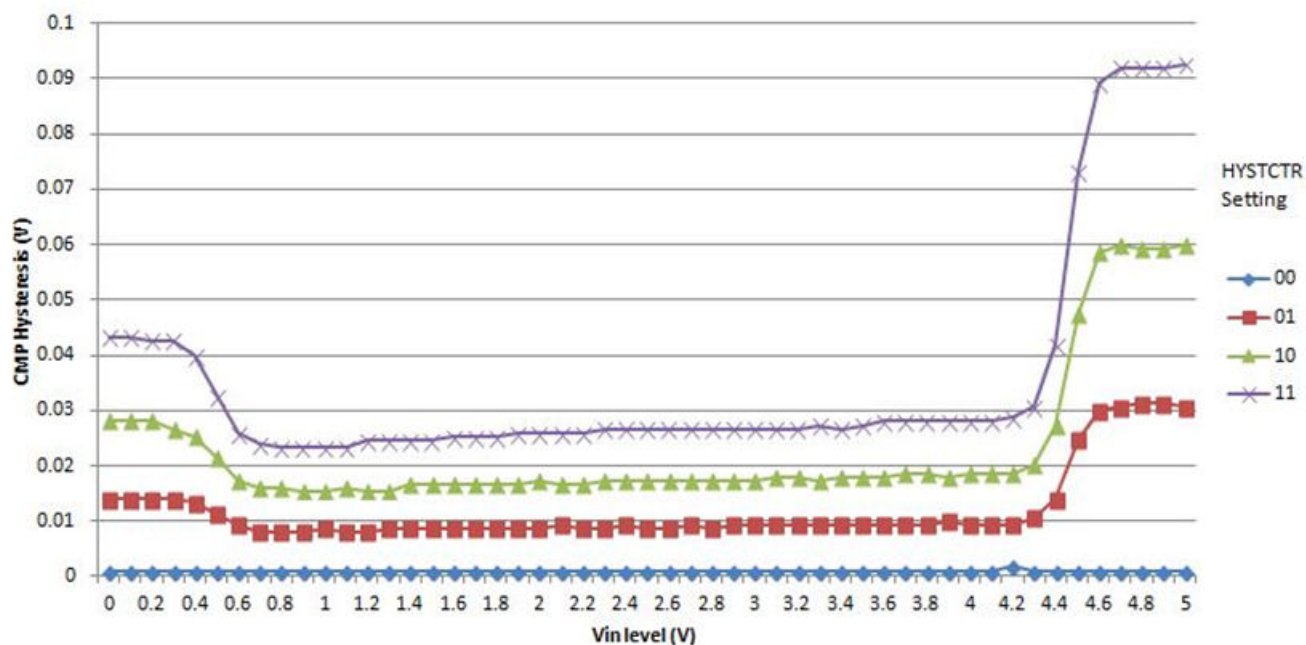

Figure 17. Typical hysteresis vs. Vin level (VDDA = 5 V, PMODE = 1)

6.5 Communication modules

6.5.1 LPUART electrical specifications

Refer to [General AC specifications](#) for LPUART specifications.

6.5.1.1 Supported baud rate

Baud rate = Baud clock / ((OSR+1) * SBR).

For details, see section: 'Baud rate generation' of the *Reference Manual*.

6.5.2 LPSPI electrical specifications

The Low Power Serial Peripheral Interface (LPSPI) provides a synchronous serial bus with master and slave operations. Many of the transfer attributes are programmable. The following tables provide timing characteristics for classic LPSPI timing modes.

- All timing is shown with respect to 20% V_{DD} and 80% V_{DD} thresholds.
- All measurements are with maximum output load of 50 pF, input transition of 1 ns and pad configured with fastest slew setting (DSE = 1).

Table 29. LPSPi electrical specifications 1

| Num | Symbol | Description | Conditions | Run Mode ² | | | | | | HSRUN Mode ² | | | | | | VL |
|-----|------------------------------------|---------------------------------------|------------------------------------|-----------------------|------|----------|------|----------|------|-------------------------|------|----------|------|----------|------|----|
| | | | | 5.0 V IO | | 3.3 V IO | | 5.0 V IO | | 3.3 V IO | | 5.0 V IO | | 3.3 V IO | | |
| | | | | Min. | Max. | Min. | Max. | Min. | Max. | Min. | Max. | Min. | Max. | Min. | Max. | |
| | f_{periph} ^{3,4} | Peripheral Frequency | Slave | - | 40 | - | 40 | - | 40 | - | 56 | - | 56 | - | 8 | |
| | | | Master | - | 40 | - | 40 | - | 56 | - | 56 | - | 56 | - | 8 | |
| | | | Master Loopback ⁵ | - | 40 | - | 48 | - | 48 | - | 48 | - | 48 | - | 8 | |
| | | | Master Loopback(Slow) ⁶ | - | 48 | - | 48 | - | 48 | - | 48 | - | 48 | - | 8 | |
| 1 | f_{op} | Frequency of operation | Slave | - | 10 | - | 10 | - | 14 | - | 14 | - | 14 | - | 4 | |
| | | | Master | - | 10 | - | 10 | - | 14 | - | 14 | - | 14 | - | 4 | |
| | | | Master Loopback ⁵ | - | 20 | - | 12 | - | 24 | - | 12 | - | 12 | - | 4 | |
| | | | Master Loopback(slow) ⁶ | - | 12 | - | 12 | - | 12 | - | 12 | - | 12 | - | 4 | |
| 2 | t_{SPSCK} | SPSCK period | Slave | 100 | - | 100 | - | 72 | - | 72 | - | 72 | - | 250 | | |
| | | | Master | 100 | - | 100 | - | 72 | - | 72 | - | 72 | - | 250 | | |
| | | | Master Loopback ⁵ | 50 | - | 83 | - | 42 | - | 83 | - | 83 | - | 250 | | |
| | | | Master Loopback(slow) ⁶ | 83 | - | 83 | - | 83 | - | 83 | - | 83 | - | 250 | | |
| 3 | t_{Lead} ⁷ | Enable lead time (PCS to SPSCK delay) | Slave | - | - | - | - | - | - | - | - | - | - | | | |

Table continues on the next page...

Table 29. LPSPi electrical specifications 1 (continued)

| Num | Symbol | Description | Conditions | Run Mode ² | | | | | | HSRUN Mode ² | | | | | | VL | | | | |
|-----|---------------------|---|------------------------------------|---------------------------|------|----------|------|---------------------------|------|-------------------------|------|---------------------------|------|---------------------------|------|---------------------------|---|----|---|---------------------------|
| | | | | 5.0 V IO | | 3.3 V IO | | 5.0 V IO | | 3.3 V IO | | 5.0 V IO | | 3.3 V IO | | | | | | |
| | | | | Min. | Max. | Min. | Max. | Min. | Max. | Min. | Max. | Min. | Max. | Min. | Max. | | | | | |
| 5 | t _{wSPSCK} | Clock(SPSC K) high or low time (SPSCK duty cycle) | Slave | t _{SPSCK} /2 - 3 | - | 5 | - | t _{SPSCK} /2 - 3 | - | 3 | - | t _{SPSCK} /2 + 3 | - | 5 | - | t _{SPSCK} /2 - 5 | - | 18 | - | t _{SPSCK} /2 + 5 |
| | | | Master | t _{SPSCK} /2 - 3 | - | 38 | - | 26 | - | 26 | - | 37 | - | t _{SPSCK} /2 + 3 | - | 72 | - | 72 | - | 72 |
| 6 | t _{SU} | Data setup time(inputs) | Master Loopback ⁵ | t _{SPSCK} /2 - 3 | - | 8 | - | 8 | - | 5 | - | t _{SPSCK} /2 + 3 | - | 7 | - | 20 | - | 20 | - | 20 |
| | | | Master Loopback(slow) ⁶ | t _{SPSCK} /2 - 3 | - | 10 | - | 7 | - | 7 | - | 9 | - | t _{SPSCK} /2 + 3 | - | 20 | - | 20 | - | 20 |
| 7 | t _{HI} | Data hold time(inputs) | Slave | t _{SPSCK} /2 - 3 | - | 3 | - | 3 | - | 3 | - | t _{SPSCK} /2 + 3 | - | 3 | - | 14 | - | 14 | - | 14 |
| | | | Master Loopback ⁵ | t _{SPSCK} /2 - 3 | - | 0 | - | 0 | - | 0 | - | 0 | - | t _{SPSCK} /2 + 3 | - | 0 | - | 0 | - | 0 |
| 8 | t _a | Slave access time | Master Loopback(slow) ⁶ | t _{SPSCK} /2 - 3 | - | 3 | - | 3 | - | 2 | - | t _{SPSCK} /2 + 3 | - | 3 | - | 11 | - | 11 | - | 11 |
| | | | Slave | t _{SPSCK} /2 - 3 | - | 3 | - | 3 | - | 3 | - | 3 | - | t _{SPSCK} /2 + 3 | - | 12 | - | 12 | - | 12 |
| 9 | t _{dis} | Slave MISO (SOUT) disable time | Slave | t _{SPSCK} /2 - 3 | - | 50 | - | 50 | - | 50 | - | t _{SPSCK} /2 + 3 | - | 50 | - | 50 | - | 50 | - | 50 |
| | | | Slave | t _{SPSCK} /2 - 3 | - | 50 | - | 50 | - | 50 | - | 50 | - | t _{SPSCK} /2 + 3 | - | 50 | - | 50 | - | 50 |

Table continues on the next page...

Table 29. LPSPi electrical specifications 1 (continued)

| Num | Symbol | Description | Conditions | Run Mode ² | | | | | | HSRUN Mode ² | | | | | | VL |
|-----|--------------------|--------------------------------|------------------------------------|-----------------------|------|----------|------|----------|------|-------------------------|------|----------|------|----------|------|----|
| | | | | 5.0 V IO | | 3.3 V IO | | 5.0 V IO | | 3.3 V IO | | 5.0 V IO | | 3.3 V IO | | |
| | | | | Min. | Max. | Min. | Max. | Min. | Max. | Min. | Max. | Min. | Max. | Min. | Max. | |
| 10 | t _v | Data valid (after SPSPCK edge) | Slave | - | 30 | - | 39 | - | 26 | - | 36 | - | 92 | 5.0 V IO | Ma | |
| | | | Master | - | 12 | - | 16 | - | 11 | - | 15 | - | 47 | | | |
| | | | Master Loopback ⁵ | - | 12 | - | 16 | - | 11 | - | 15 | - | 47 | | | |
| | | | Master Loopback(slow) ⁶ | - | 8 | - | 10 | - | 7 | - | 9 | - | 44 | | | |
| 11 | t _{HO} | Data hold time(outputs) | Slave | 4 | - | 4 | - | 4 | - | 4 | - | 4 | - | 4 | - | |
| | | | Master | -15 | - | -22 | - | -15 | - | -23 | - | -22 | - | -22 | - | |
| | | | Master Loopback ⁵ | -10 | - | -14 | - | -10 | - | -14 | - | -14 | - | -14 | - | |
| | | | Master Loopback(slow) ⁶ | -15 | - | -22 | - | -15 | - | -22 | - | -21 | - | -21 | - | |
| 12 | t _{RI/FI} | Rise/Fall time input | Slave | - | 1 | - | 1 | - | 1 | - | 1 | - | 1 | - | 1 | |
| | | | Master | - | - | - | - | - | - | - | - | - | - | - | - | |
| | | | Master Loopback ⁵ | - | - | - | - | - | - | - | - | - | - | - | - | |
| | | | Master Loopback(slow) ⁶ | - | - | - | - | - | - | - | - | - | - | - | - | |
| 13 | t _{RO/FO} | Rise/Fall time output | Slave | - | 25 | - | 25 | - | 25 | - | 25 | - | 25 | - | 25 | |
| | | | Master | - | - | - | - | - | - | - | - | - | - | - | - | |
| | | | Master Loopback ⁵ | - | - | - | - | - | - | - | - | - | - | - | - | |
| | | | Master Loopback(slow) ⁶ | - | - | - | - | - | - | - | - | - | - | - | - | |

- Trace length should not exceed 11 inches for SCK pad when used in Master loopback mode.
- While transitioning from HSRUN mode to RUN mode, LPSPi output clock should not be more than 14 MHz.
- f_{periph} = LPSPi peripheral clock

4. $t_{\text{periph}} = 1/f_{\text{periph}}$
5. Master Loopback mode - In this mode LPSPI_SCK clock is delayed for sampling the input data which is enabled by setting LPSPI_CFG0.Clock pads used are PTD15 and PTE0. Applicable only for LPSPI0.
6. Master Loopback (slow) - In this mode LPSPI_SCK clock is delayed for sampling the input data which is enabled by setting LPSPI_CFG0.Clock pad used is PTB2. Applicable only for LPSPI0.
7. Set the PCSSCK configuration bit as 0, for a minimum of 1 delay cycle of LPSPI baud rate clock, where PCSSCK ranges from 0 to 255.
8. Set the SCKPCS configuration bit as 0, for a minimum of 1 delay cycle of LPSPI baud rate clock, where SCKPCS ranges from 0 to 255.

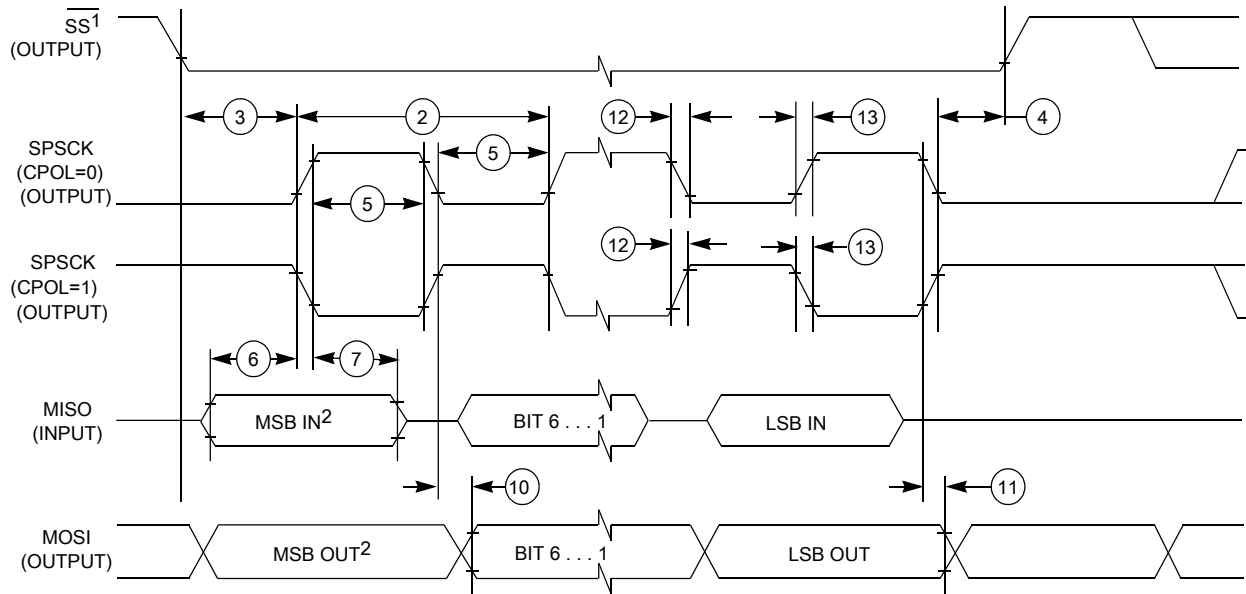

1. If configured as an output.
2. LSBF = 0. For LSBF = 1, bit order is LSB, bit 1, ..., bit 6, MSB.

Figure 18. LPSPI master mode timing (CPHA = 0)

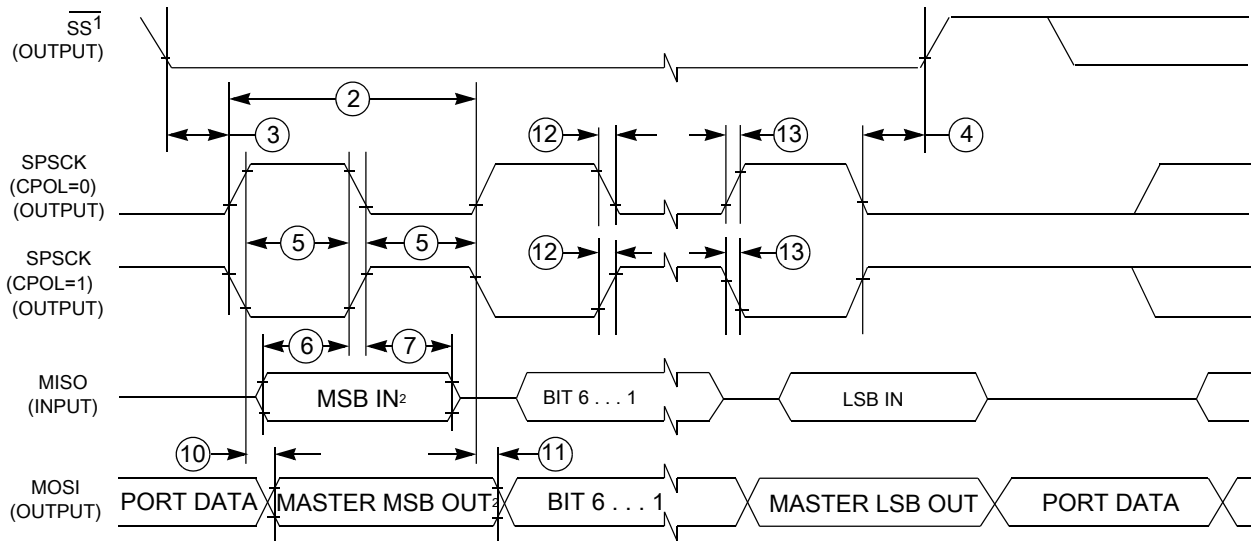

1. If configured as output
2. LSBF = 0. For LSBF = 1, bit order is LSB, bit 1, ..., bit 6, MSB.

Figure 19. LPSPI master mode timing (CPHA = 1)

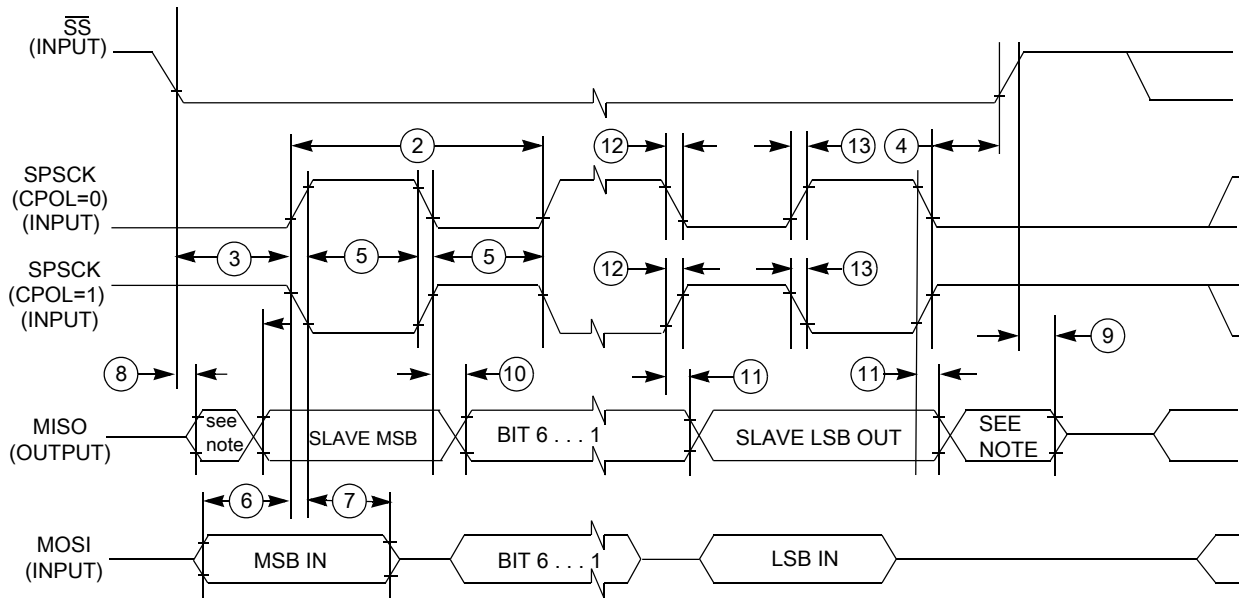

Figure 20. LPSPI slave mode timing (CPHA = 0)

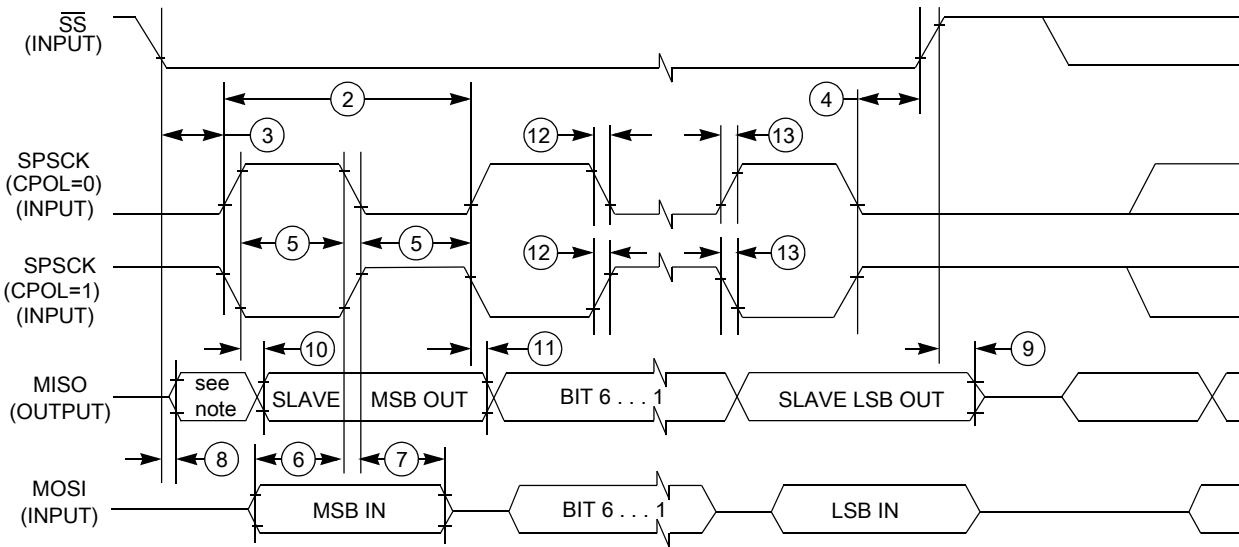

Figure 21. LPSPI slave mode timing (CPHA = 1)

6.5.3 LPI2C electrical specifications

See [General AC specifications](#) for LPI2C specifications.

For supported baud rate see section 'Chip-specific LPI2C information' of the *Reference Manual*.

6.5.4 FlexCAN electrical specifications

For supported baud rate, see section 'Protocol timing' of the *Reference Manual*.

6.5.5 SAI electrical specifications

The following table describes the SAI electrical characteristics.

- Measurements are with maximum output load of 50 pF, input transition of 1 ns and pad configured with fastest slew settings (DSE = 1'b1).
- I/O operating voltage ranges from 2.97 V to 3.6 V
- While doing the mode transition (RUN -> HSRUN or HSRUN -> RUN), the interface should be OFF.

Table 30. Master mode timing specifications

| Symbol | Description | Min. | Max. | Unit |
|--------|-------------------------------------|------|------|-------------|
| — | Operating voltage | 2.97 | 3.6 | V |
| S1 | SAI_MCLK cycle time | 40 | — | ns |
| S2 | SAI_MCLK pulse width high/low | 45% | 55% | MCLK period |
| S3 | SAI_BCLK cycle time | 80 | — | ns |
| S4 | SAI_BCLK pulse width high/low | 45% | 55% | BCLK period |
| S5 | SAI_RXD input setup before SAI_BCLK | 28 | — | ns |
| S6 | SAI_RXD input hold after SAI_BCLK | 0 | — | ns |
| S7 | SAI_BCLK to SAI_TXD output valid | — | 8 | ns |
| S8 | SAI_BCLK to SAI_TXD output invalid | -2 | — | ns |
| S9 | SAI_FS input setup before SAI_BCLK | 28 | — | ns |
| S10 | SAI_FS input hold after SAI_BCLK | 0 | — | ns |
| S11 | SAI_BCLK to SAI_FS output valid | — | 8 | ns |
| S12 | SAI_BCLK to SAI_FS output invalid | -2 | — | ns |

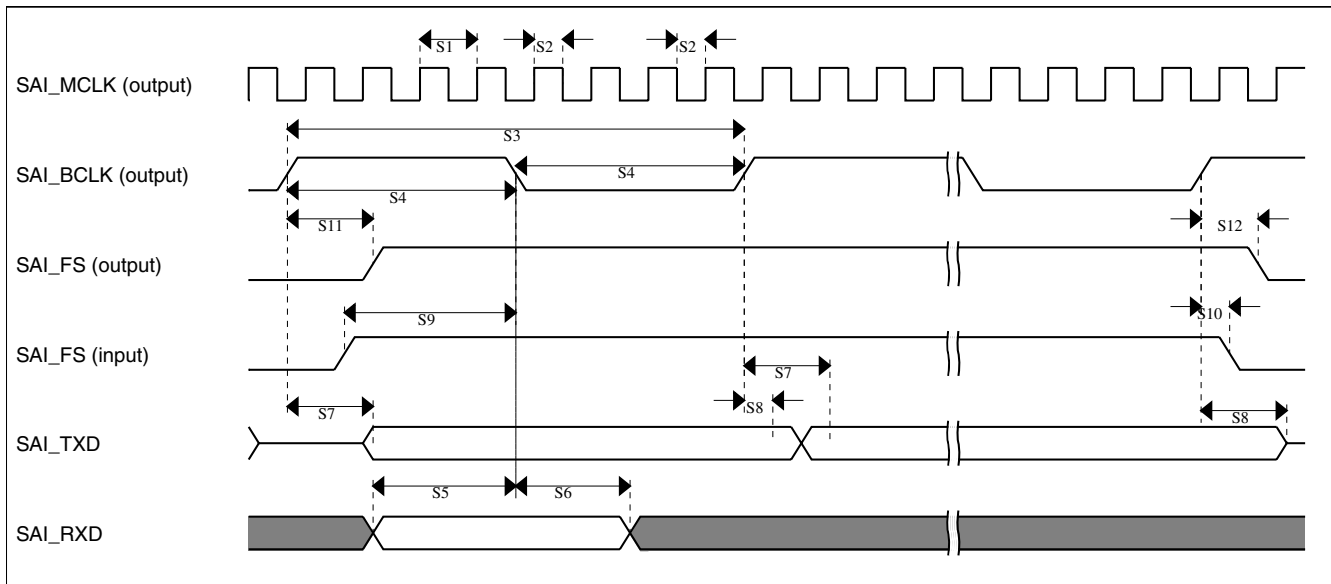

Figure 22. SAI Timing — Master modes

Table 31. Slave mode timing specifications

| Symbol | Description | Min. | Max. | Unit |
|------------------|---------------------------------------|------|------|-------------|
| — | Operating voltage | 2.97 | 3.6 | V |
| S13 | SAI_BCLK cycle time (input) | 80 | — | ns |
| S14 ¹ | SAI_BCLK pulse width high/low (input) | 45% | 55% | BCLK period |
| S15 | SAI_RXD input setup before SAI_BCLK | 8 | — | ns |
| S16 | SAI_RXD input hold after SAI_BCLK | 2 | — | ns |
| S17 | SAI_BCLK to SAI_TXD output valid | — | 28 | ns |
| S18 | SAI_BCLK to SAI_TXD output invalid | 0 | — | ns |
| S19 | SAI_FS input setup before SAI_BCLK | 8 | — | ns |
| S20 | SAI_FS input hold after SAI_BCLK | 2 | — | ns |
| S21 | SAI_BCLK to SAI_FS output valid | — | 28 | ns |
| S22 | SAI_BCLK to SAI_FS output invalid | 0 | — | ns |

1. The slave mode parameters (S15 - S22) assume 50% duty cycle on SAI_BCLK input. Any change in SAI_BCLK duty cycle input must be taken care during the board design or by the master timing.

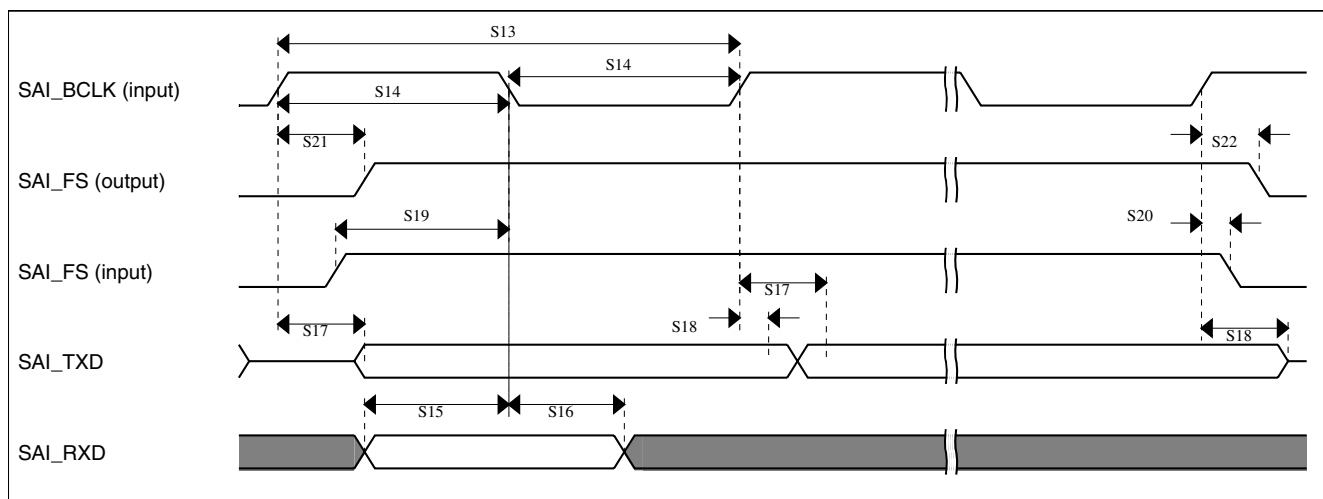

Figure 23. SAI Timing — Slave modes

6.5.6 Ethernet AC specifications

The following timing specs are defined at the chip I/O pin and must be translated appropriately to arrive at timing specs/constraints for the physical interface.

The following table describes the MII electrical characteristics.

- Measurements are with maximum output load of 25 pF, input transition of 1 ns and pad configured with fastest slew settings (DSE = 1'b1).
- I/O operating voltage ranges from 2.97 V to 3.6 V
- While doing the mode transition (RUN -> HSRUN or HSRUN -> RUN), the interface should be OFF.

Table 32. MII signal switching specifications

| Symbol | Description | Min. | Max. | Unit |
|--------|---------------------------------------|------|------|--------------|
| — | RXCLK frequency | — | 25 | MHz |
| MII1 | RXCLK pulse width high | 35% | 65% | RXCLK period |
| MII2 | RXCLK pulse width low | 35% | 65% | RXCLK period |
| MII3 | RXD[3:0], RXDV, RXER to RXCLK setup | 5 | — | ns |
| MII4 | RXCLK to RXD[3:0], RXDV, RXER hold | 5 | — | ns |
| — | TXCLK frequency | — | 25 | MHz |
| MII5 | TXCLK pulse width high | 35% | 65% | TXCLK period |
| MII6 | TXCLK pulse width low | 35% | 65% | TXCLK period |
| MII7 | TXCLK to TXD[3:0], TXEN, TXER invalid | 2 | — | ns |
| MII8 | TXCLK to TXD[3:0], TXEN, TXER valid | — | 25 | ns |

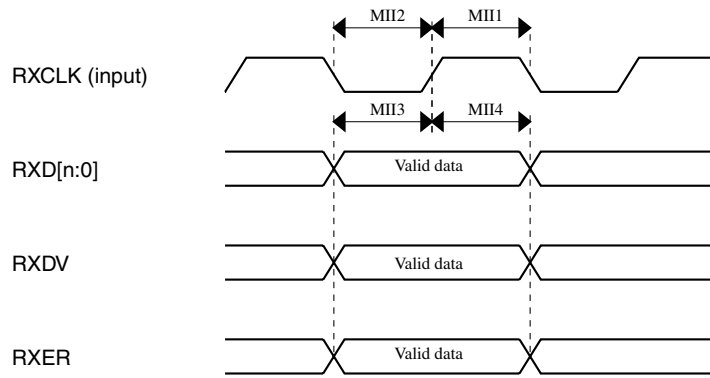

Figure 24. MII receive diagram

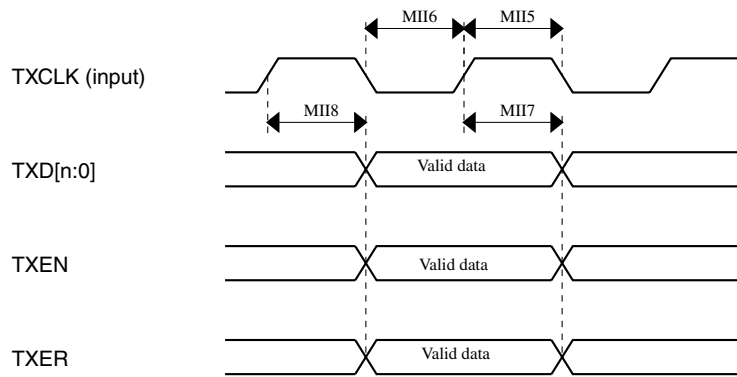

Figure 25. MII transmit signal diagram

The following table describes the RMII electrical characteristics.

- Measurements are with maximum output load of 25 pF, input transition of 1 ns and pad configured with fastest slew settings (DSE = 1'b1).
- I/O operating voltage ranges from 2.97 V to 3.6 V
- While doing the mode transition (RUN -> HSRUN or HSRUN -> RUN), the interface should be OFF.

Table 33. RMII signal switching specifications

| Symbol | Description | Min. | Max. | Unit |
|--------------|--|------|------|-----------------|
| — | RMII input clock RMII_CLK Frequency | — | 50 | MHz |
| RMII1, RMII5 | RMII_CLK pulse width high | 35% | 65% | RMII_CLK period |
| RMII2, RMII6 | RMII_CLK pulse width low | 35% | 65% | RMII_CLK period |
| RMII3 | RXD[1:0], CRS_DV, RXER to RMII_CLK setup | 4 | — | ns |
| RMII4 | RMII_CLK to RXD[1:0], CRS_DV, RXER hold | 2 | — | ns |

Table continues on the next page...

**Table 33. RMI signal switching specifications
(continued)**

| Symbol | Description | Min. | Max. | Unit |
|--------|-----------------------------------|------|------|------|
| RMI7 | RMI_CLK to TXD[1:0], TXEN invalid | 2 | — | ns |
| RMI8 | RMI_CLK to TXD[1:0], TXEN valid | — | 15 | ns |

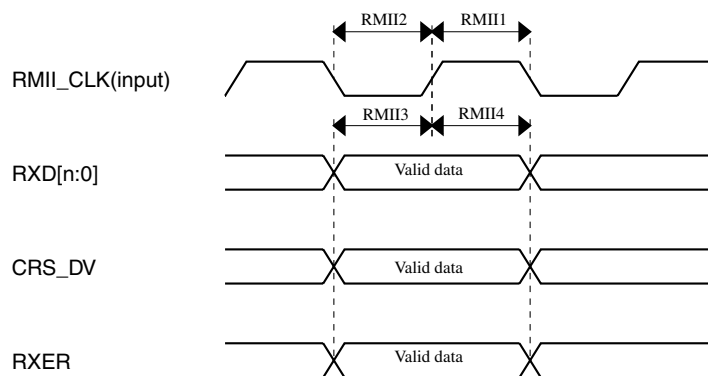
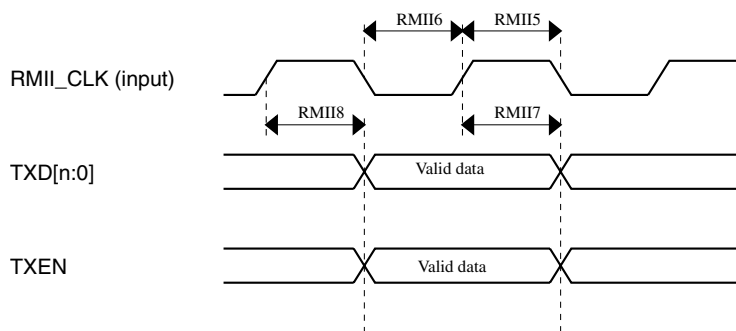
**Figure 26. RMI receive diagram****Figure 27. RMI transmit diagram**

The following table describes the MDIO electrical characteristics.

- Measurements are with maximum output load of 25 pF, input transition of 1 ns and pad configured with fastest slew settings (DSE = 1'b1).
- I/O operating voltage ranges from 2.97 V to 3.6 V
- While doing the mode transition (RUN -> HSRUN or HSRUN -> RUN), the interface should be OFF.
- MDIO pin must have external Pull-up.

Table 34. MDIO timing specifications

| Symbol | Description | Min. | Max. | Unit |
|--------|---------------------|------|------|------|
| — | MDC Clock Frequency | — | 2.5 | MHz |

Table continues on the next page...

Table 34. MDIO timing specifications (continued)

| Symbol | Description | Min. | Max. | Unit |
|--------|---|------|------|------------|
| MDC1 | MDC pulse width high | 40% | 60% | MDC period |
| MDC2 | MDC pulse width low | 40% | 60% | MDC period |
| MDC3 | MDIO (input) to MDC rising edge setup | 25 | — | ns |
| MDC4 | MDIO (input) to MDC rising edge hold | 0 | — | ns |
| MDC5 | MDC falling edge to MDIO output valid (maximum propagation delay) | — | 25 | ns |
| MDC6 | MDC falling edge to MDIO output invalid (minimum propagation delay) | -10 | — | ns |

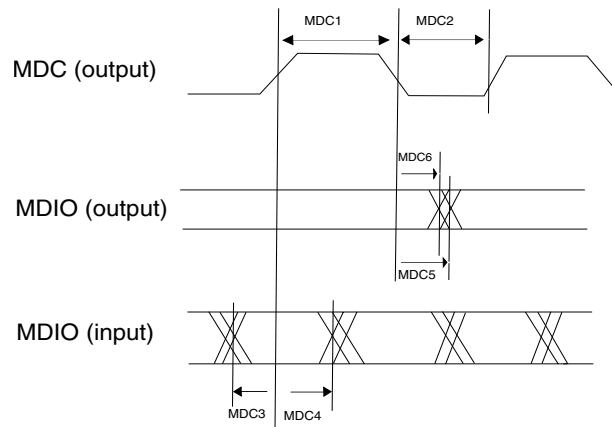

Figure 28. MII/RMII serial management channel timing diagram

6.5.7 Clockout frequency

Maximum supported clock out frequency for this device is 20 MHz

6.6 Debug modules

6.6.1 SWD electrical specifications

Table 35. SWD electrical specifications

| Symbol | Description | Run Mode | | | | | | HSRUN Mode | | | | | | VL | | | |
|--------|---|----------|----------|----------|----------|----------|----------|------------|----------|----------|----------|----------|----------|----------|----------|----------|----------|
| | | 5.0 V IO | | 3.3 V IO | | 5.0 V IO | | 3.3 V IO | | 5.0 V IO | | 3.3 V IO | | 5.0 V IO | Min. | Max. | |
| | | Min. | Max. | Min. | Max. | Min. | Max. | Min. | Max. | Min. | Max. | Min. | Max. | Min. | Max. | | |
| S1 | SWD_CLK frequency of operation | - | 25 | - | 25 | - | 25 | - | 25 | - | 25 | - | 25 | - | 25 | - | 10 |
| S2 | SWD_CLK cycle period | 1/S1 | - | 1/S1 | - | 1/S1 | - | 1/S1 | - | 1/S1 | - | 1/S1 | - | 1/S1 | - | - | - |
| S3 | SWD_CLK clock pulse width | S2/2 - 5 | S2/2 + 5 | S2/2 - 5 | S2/2 + 5 | S2/2 - 5 | S2/2 + 5 | S2/2 - 5 | S2/2 + 5 | S2/2 - 5 | S2/2 + 5 | S2/2 - 5 | S2/2 + 5 | S2/2 - 5 | S2/2 + 5 | S2/2 - 5 | S2/2 + 5 |
| S4 | SWD_CLK rise and fall times | - | 1 | - | 1 | - | 1 | - | 1 | - | 1 | - | 1 | - | 1 | - | 1 |
| S9 | SWD_DIO input data setup time to SWD_CLK rise | 4 | - | 4 | - | 4 | - | 4 | - | 4 | - | 4 | - | 4 | - | 16 | - |
| S10 | SWD_DIO input data hold time after SWD_CLK rise | 3 | - | 3 | - | 3 | - | 3 | - | 3 | - | 3 | - | 3 | - | 10 | - |
| S11 | SWD_CLK high to SWD_DIO data valid | - | 28 | - | 38 | - | 38 | - | 28 | - | 28 | - | 38 | - | 38 | - | 70 |
| S12 | SWD_CLK high to SWD_DIO high-Z | - | 28 | - | 38 | - | 38 | - | 28 | - | 28 | - | 38 | - | 38 | - | 70 |
| S13 | SWD_CLK high to SWD_DIO data invalid | 0 | - | 0 | - | 0 | - | 0 | - | 0 | - | 0 | - | 0 | - | 0 | - |

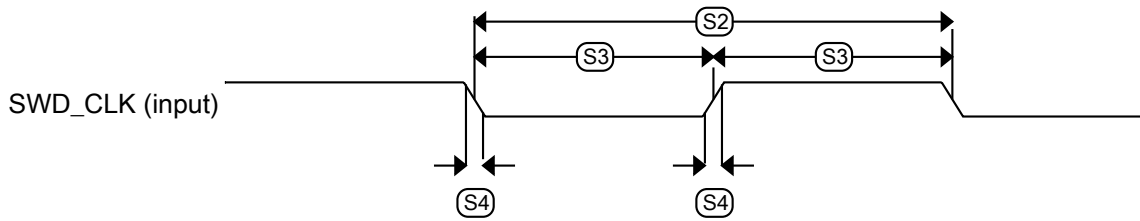

Figure 29. Serial wire clock input timing

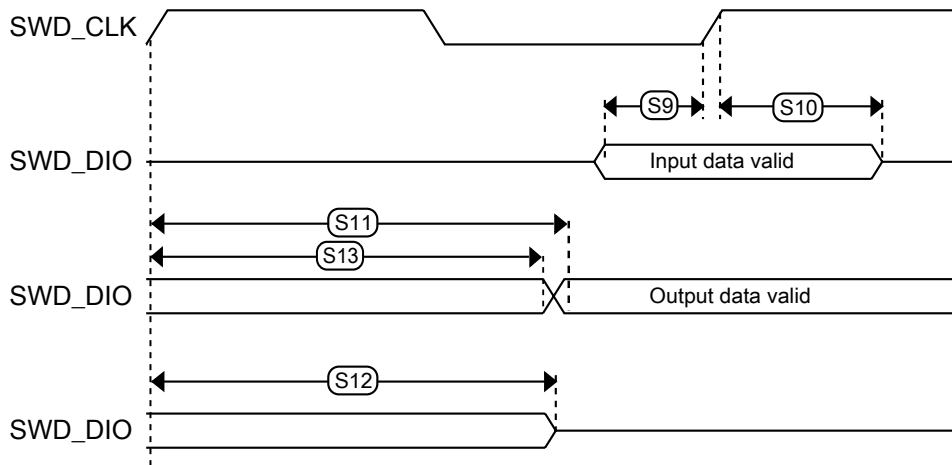

Figure 30. Serial wire data timing

6.6.2 Trace electrical specifications

The following table describes the Trace electrical characteristics.

- Measurements are with maximum output load of 50 pF, input transition of 1 ns and pad configured with fastest slew settings (DSE = 1'b1).
- While doing the mode transition (RUN -> HSRUN or HSRUN -> RUN), the interface should be OFF.

Table 36. Trace specifications

| | Symbol | Description | RUN Mode | | | HSRUN Mode | | VLPR Mode | Unit |
|---|--------|------------------|----------|----|----|------------|----|-----------|------|
| | | | 80 | 48 | 40 | 112 | 80 | | |
| — | Fsys | System frequency | 80 | 48 | 40 | 112 | 80 | 4 | MHz |

Table continues on the next page...

Table 36. Trace specifications (continued)

| | Symbol | Description | RUN Mode | | | HSRUN Mode | | VLPR Mode | Unit |
|--------------------|-------------|---------------------|----------|----|----|------------|-------|-----------|------|
| Trace on fast pads | f_{TRACE} | Max Trace frequency | 80 | 48 | 40 | 74.667 | 80 | 4 | MHz |
| | t_{DVO} | Data Output Valid | 4 | 4 | 4 | 4 | 4 | 20 | ns |
| | t_{DIV} | Data Output Invalid | -2 | -2 | -2 | -2 | -2 | -10 | ns |
| Trace on slow pads | f_{TRACE} | Max Trace frequency | 22.86 | 24 | 20 | 22.4 | 22.86 | 4 | MHz |
| | t_{DVO} | Data Output Valid | 8 | 8 | 8 | 8 | 8 | 20 | ns |
| | t_{DIV} | Data Output Invalid | -4 | -4 | -4 | -4 | -4 | -10 | ns |

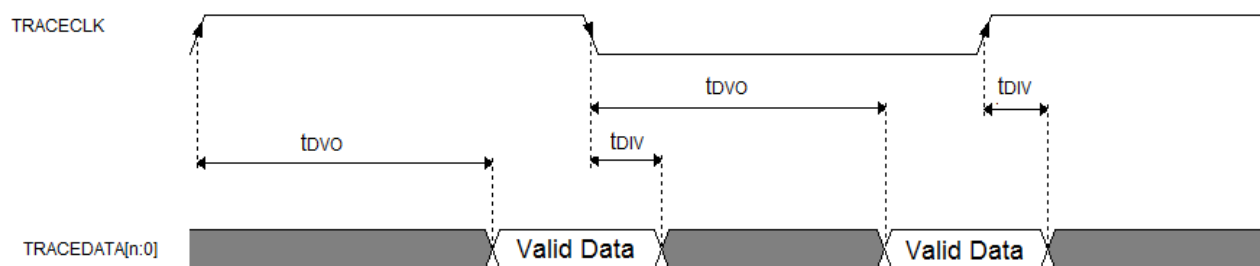

Figure 31. TRACE CLKOUT specifications

6.6.3 JTAG electrical specifications

Table 37. JTAG electrical specifications

| Symbol | Description | Run Mode | | | | HSRUN Mode | | | | VLPR | | | |
|--------|--|----------|----------|----------|----------|------------|----------|----------|----------|----------|----------|----------|----------|
| | | 5.0 V IO | | 3.3 V IO | | 5.0 V IO | | 3.3 V IO | | 5.0 V IO | | | |
| | | Min. | Max. | Min. | Max. | Min. | Max. | Min. | Max. | Min. | Max. | | |
| J1 | TCLK frequency of operation | | | | | | | | | | | | |
| | Boundary Scan | - | 20 | - | 20 | - | 20 | - | 20 | - | 20 | - | 10 |
| | JTAG | - | 20 | - | 20 | - | 20 | - | 20 | - | 20 | - | 10 |
| J2 | TCLK cycle period | 1/J1 | - | 1/J1 | - | 1/J1 | - | 1/J1 | - | 1/J1 | - | 1/J1 | - |
| J3 | TCLK clock pulse width | | | | | | | | | | | | |
| | Boundary Scan | J2/2 - 5 | J2/2 + 5 | J2/2 - 5 | J2/2 + 5 | J2/2 - 5 | J2/2 + 5 | J2/2 - 5 | J2/2 + 5 | J2/2 - 5 | J2/2 + 5 | J2/2 - 5 | J2/2 + 5 |
| | JTAG | J2/2 - 5 | J2/2 + 5 | J2/2 - 5 | J2/2 + 5 | J2/2 - 5 | J2/2 + 5 | J2/2 - 5 | J2/2 + 5 | J2/2 - 5 | J2/2 + 5 | J2/2 - 5 | J2/2 + 5 |
| J4 | TCLK rise and fall times | - | 1 | - | 1 | - | 1 | - | 1 | - | 1 | - | 1 |
| J5 | Boundary scan input data setup time to TCLK rise | 5 | - | 5 | - | 5 | - | 5 | - | 5 | - | 15 | - |
| J6 | Boundary scan input data hold time after TCLK rise | 5 | - | 5 | - | 5 | - | 5 | - | 5 | - | 8 | - |
| J7 | TCLK low to boundary scan output data valid | - | 28 | - | 32 | - | 28 | - | 32 | - | 28 | - | 80 |
| J8 | TCLK low to boundary scan output data invalid | 0 | - | 0 | - | 0 | - | 0 | - | 0 | - | 0 | - |
| J9 | TCLK low to boundary scan output high-Z | - | 28 | - | 32 | - | 28 | - | 32 | - | 28 | - | 80 |
| J10 | TMS, TDI input data setup time to TCLK rise | 3 | - | 3 | - | 3 | - | 3 | - | 3 | - | 15 | - |
| J11 | TMS, TDI input data hold time after TCLK rise | 2 | - | 2 | - | 2 | - | 2 | - | 2 | - | 8 | - |
| J12 | TCLK low to TDO data valid | - | 28 | - | 32 | - | 28 | - | 32 | - | 28 | - | 80 |
| J13 | TCLK low to TDO data invalid | 0 | - | 0 | - | 0 | - | 0 | - | 0 | - | 0 | - |
| J14 | TCLK low to TDO high-Z | - | 28 | - | 32 | - | 28 | - | 32 | - | 28 | - | 80 |

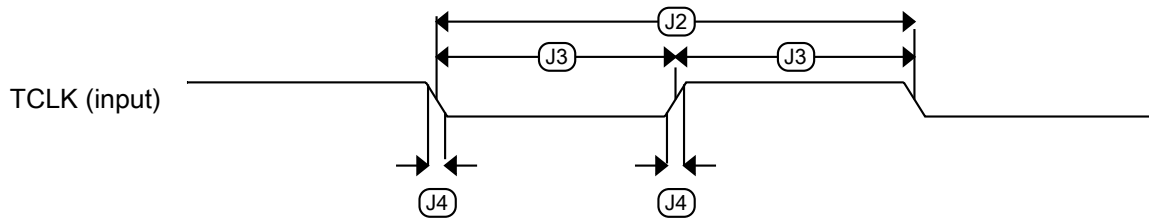

Figure 32. Test clock input timing

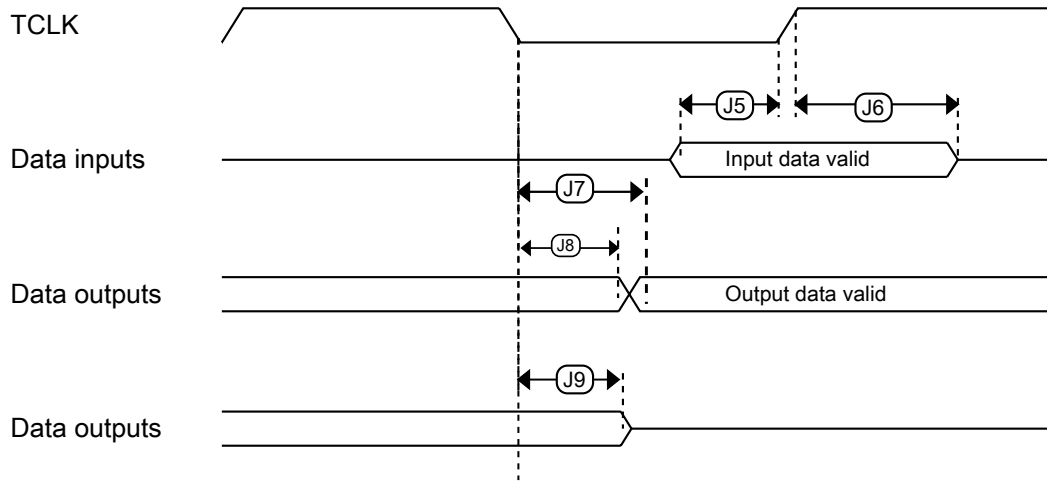

Figure 33. Boundary scan (JTAG) timing

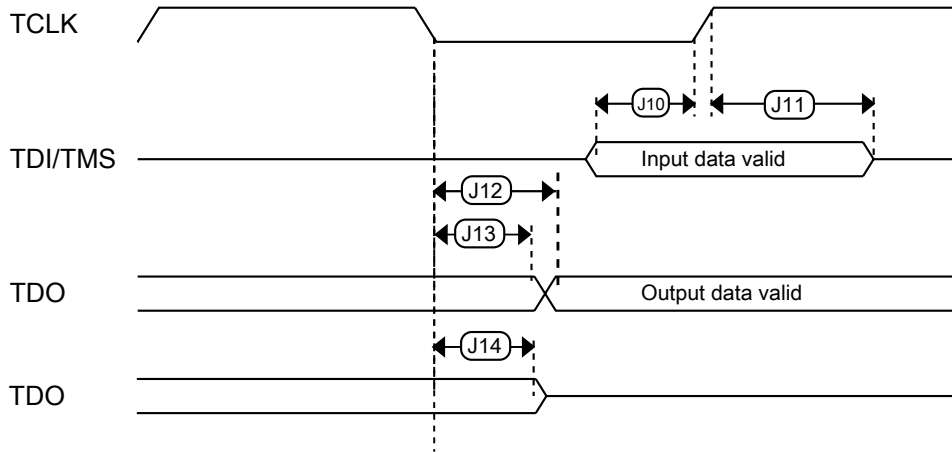

Figure 34. Test Access Port timing

7 Thermal attributes

7.1 Description

The tables in the following sections describe the thermal characteristics of the device.

NOTE

Junction temperature is a function of die size, on-chip power dissipation, package thermal resistance, mounting side (board) temperature, ambient temperature, air flow, power dissipation or other components on the board, and board thermal resistance.

7.2 Thermal characteristics

Table 38. Thermal characteristics for the 64/100/144/176-pin LQFP package

| Rating | Conditions | Symbol | Packages | Values | | | |
|--|----------------------------|-------------------|----------|---------|---------|---------|---------|
| | | | | S32K11x | S32K142 | S32K144 | S32K144 |
| Thermal resistance, Junction to Ambient (Natural Convection) ^{1,2} | Single layer board (1s) | R _{θJA} | 64 | TBD | 61 | 61 | 59 |
| | | | 100 | TBD | 53 | 52 | 21 |
| | | | 144 | TBD | NA | NA | 51 |
| | | | 176 | TBD | NA | NA | NA |
| Thermal resistance, Junction to Ambient (Natural Convection) ¹ | Two layer board (1s1p) | R _{θJA} | 64 | TBD | 45 | 45 | 44 |
| | | | 100 | TBD | 42 | 42 | 40 |
| | | | 144 | TBD | NA | NA | 44 |
| | | | 176 | TBD | NA | NA | NA |
| Thermal resistance, Junction to Ambient (Natural Convection) ^{1,2} | Four layer board (2s2p) | R _{θJA} | 64 | TBD | 43 | 43 | 41 |
| | | | 100 | TBD | 40 | 40 | 39 |
| | | | 144 | TBD | NA | NA | 42 |
| | | | 176 | TBD | NA | NA | NA |
| Thermal resistance, Junction to Ambient (@ 200 ft/min) ^{1,3} | Single layer board (1s) | R _{θJMA} | 64 | TBD | 49 | 49 | 48 |
| | | | 100 | TBD | 43 | 42 | 41 |
| | | | 144 | TBD | NA | NA | 42 |
| | | | 176 | TBD | NA | NA | NA |
| Thermal resistance, Junction to Ambient (@ 200 ft/min) ¹ | Two layer board (1s1p) | R _{θJMA} | 64 | TBD | 38 | 38 | 37 |
| | | | 100 | TBD | 35 | 35 | 34 |
| | | | 144 | TBD | NA | NA | 37 |
| | | | 176 | TBD | NA | NA | NA |
| Thermal resistance, Junction to Ambient (@ 200 ft/min) ^{1,3} | Four layer board (2s2p) | R _{θJMA} | 64 | TBD | 36 | 36 | 35 |
| | | | 100 | TBD | 34 | 34 | 33 |
| | | | 144 | TBD | NA | NA | 36 |
| | | | 176 | TBD | NA | NA | NA |
| Thermal resistance, Junction to Board ⁴ | — | R _{θJB} | 64 | TBD | 25 | 25 | 23 |
| | | | 100 | TBD | 25 | 25 | 24 |
| | | | 144 | TBD | NA | NA | 30 |
| | | | 176 | TBD | NA | NA | NA |

Table continues on the next page...

Table 38. Thermal characteristics for the 64/100/144/176-pin LQFP package (continued)

| Rating | Conditions | Symbol | Packages | Values | | | |
|--|--------------------|-----------------|----------|---------|---------|---------|---------|
| | | | | S32K11x | S32K142 | S32K144 | S32K144 |
| Thermal resistance, Junction to Case ⁵ | — | $R_{\theta JC}$ | 64 | TBD | 13 | 12 | 11 |
| | | | 100 | TBD | 13 | 12 | 11 |
| | | | 144 | TBD | NA | NA | 12 |
| | | | 176 | TBD | NA | NA | NA |
| Thermal resistance, Junction to Package Top ⁶ | Natural Convection | ψ_{JT} | 64 | TBD | 2 | 2 | 2 |
| | | | 100 | TBD | 2 | 2 | 2 |
| | | | 144 | TBD | NA | NA | 2 |
| | | | 176 | TBD | NA | NA | NA |

1. Junction temperature is a function of die size, on-chip power dissipation, package thermal resistance, mounting site (board) temperature, flow, power dissipation of other components on the board, and board thermal resistance.
2. Per JEDEC JESD51-2 with natural convection for horizontally oriented board. Board meets JESD51-9 specification for 1s or 2s2p board.
3. Per JEDEC JESD51-6 with forced convection for horizontally oriented board. Board meets JESD51-9 specification for 1s or 2s2p board.
4. Thermal resistance between the die and the printed circuit board per JEDEC JESD51-8. Board temperature is measured on the top surface of the package.
5. Thermal resistance between the die and the case top surface as measured by the cold plate method (MIL SPEC-883 Method 1012.1).
6. Thermal characterization parameter indicating the temperature difference between package top and the junction temperature per JEDEC. If letters are not available, the thermal characterization parameter is written as Psi-JT.

Table 39. Thermal characteristics for the 100 MAPBGA package

| Rating | Conditions | Symbol | Values | |
|---|-------------------------|-------------------|---------|---------|
| | | | S32K146 | S32K144 |
| Thermal resistance, Junction to Ambient (Natural Convection) ^{1, 2} | Single layer board (1s) | R _{θJA} | 57.2 | 61.0 |
| Thermal resistance, Junction to Ambient (Natural Convection) ^{1, 2, 3} | Four layer board (2s2p) | R _{θJA} | 32.1 | 35.6 |
| Thermal resistance, Junction to Ambient (@200 ft/min) ^{1, 2, 3} | Single layer board (1s) | R _{θJMA} | 44.1 | 46.6 |
| Thermal resistance, Junction to Ambient (@200 ft/min) ^{1, 3} | Two layer board (2s2p) | R _{θJMA} | 27.2 | 30.9 |
| Thermal resistance, Junction to Board ⁴ | — | R _{θJB} | 15.3 | 18.9 |
| Thermal resistance, Junction to Case ⁵ | — | R _{θJC} | 10.2 | 14.2 |
| Thermal resistance, Junction to Package Top outside center ⁶ | — | ψ _{JT} | 0.2 | 0.4 |
| Thermal resistance, Junction to Package Bottom outside center ⁷ | — | ψ _{JB} | 12.2 | 15.9 |

1. Junction temperature is a function of die size, on-chip power dissipation, package thermal resistance, mounting site (board) temperature, flow, power dissipation of other components on the board, and board thermal resistance.
2. Per SEMI G38-87 and JEDEC JESD51-2 with the single layer board horizontal.
3. Per JEDEC JESD51-6 with the board horizontal.
4. Thermal resistance between the die and the printed circuit board per JEDEC JESD51-8. Board temperature is measured on the top surface of the package.
5. Thermal resistance between the die and the case top surface as measured by the cold plate method (MIL SPEC-883 Method 1012.1).
6. Thermal characterization parameter indicating the temperature difference between package top and the junction temperature per JEDEC Method 1012.1. When Greek letters are not available, the thermal characterization parameter is written as Psi-JT.
7. Thermal characterization parameter indicating the temperature difference between package bottom center and the junction temperature per JEDEC Method 1012.1. When Greek letters are not available, the thermal characterization parameter is written as Psi-JB.

7.3 General notes for specifications at maximum junction temperature

An estimation of the chip junction temperature, T_J , can be obtained from this equation:

$$T_J = T_A + (R_{\theta JA} \times P_D)$$

where:

- T_A = ambient temperature for the package ($^{\circ}\text{C}$)
- $R_{\theta JA}$ = junction to ambient thermal resistance ($^{\circ}\text{C}/\text{W}$)
- P_D = power dissipation in the package (W)

The junction to ambient thermal resistance is an industry standard value that provides a quick and easy estimation of thermal performance. Unfortunately, there are two values in common usage: the value determined on a single layer board and the value obtained on a board with two planes. For packages such as the PBGA, these values can be different by a factor of two. Which value is closer to the application depends on the power dissipated by other components on the board. The value obtained on a single layer board is appropriate for the tightly packed printed circuit board. The value obtained on the board with the internal planes is usually appropriate if the board has low power dissipation and the components are well separated.

When a heat sink is used, the thermal resistance is expressed in the following equation as the sum of a junction-to-case thermal resistance and a case-to-ambient thermal resistance:

$$R_{\theta JA} = R_{\theta JC} + R_{\theta CA}$$

where:

- $R_{\theta JA}$ = junction to ambient thermal resistance ($^{\circ}\text{C}/\text{W}$)
- $R_{\theta JC}$ = junction to case thermal resistance ($^{\circ}\text{C}/\text{W}$)
- $R_{\theta CA}$ = case to ambient thermal resistance ($^{\circ}\text{C}/\text{W}$)

$R_{\theta JC}$ is device related and cannot be influenced by the user. The user controls the thermal environment to change the case to ambient thermal resistance, $R_{\theta CA}$. For instance, the user can change the size of the heat sink, the air flow around the device, the interface material, the mounting arrangement on printed circuit board, or change the thermal dissipation on the printed circuit board surrounding the device.

To determine the junction temperature of the device in the application when heat sinks are not used, the Thermal Characterization Parameter (Ψ_{JT}) can be used to determine the junction temperature with a measurement of the temperature at the top center of the package case using this equation:

$$T_J = T_T + (\Psi_{JT} \times P_D)$$

where:

- T_T = thermocouple temperature on top of the package ($^{\circ}\text{C}$)
- Ψ_{JT} = thermal characterization parameter ($^{\circ}\text{C}/\text{W}$)
- P_D = power dissipation in the package (W)

The thermal characterization parameter is measured per JESD51-2 specification using a 40 gauge type T thermocouple epoxied to the top center of the package case. The thermocouple should be positioned so that the thermocouple junction rests on the package. A small amount of epoxy is placed over the thermocouple junction and over about 1 mm of wire extending from the junction. The thermocouple wire is placed flat against the package case to avoid measurement errors caused by cooling effects of the thermocouple wire.

8 Dimensions

8.1 Obtaining package dimensions

Package dimensions are provided in the package drawings.

To find a package drawing, go to <http://www.nxp.com> and perform a keyword search for the drawing's document number:

| Package option | Document Number |
|----------------|-----------------------|
| 32-pin QFN | SOT617-3 ¹ |
| 48-pin LQFP | 98ASH00962A |
| 64-pin LQFP | 98ASS23234W |
| 100-pin LQFP | 98ASS23308W |
| 100 MAP BGA | 98ASA00802D |
| 144-pin LQFP | 98ASS23177W |
| 176-pin LQFP | 98ASS23479W |

1. 5x5 mm package

9 Pinouts

9.1 Package pinouts and signal descriptions

For package pinouts and signal descriptions, refer to the Reference Manual.

10 Revision History

The following table provides a revision history for this document.

Table 40. Revision History

| Rev. No. | Date | Substantial Changes |
|----------|---------------|---|
| 1 | 12 Aug 2016 | Initial release |
| 2 | 03 March 2017 | <ul style="list-style-type: none"> • Updated description of QSPI and Clock interfaces in Key Features section • Updated figure: High-level architecture diagram for the S32K1xx family • Updated figure: S32K1xx product series comparison • Added note in section Determining valid orderable parts • Updated figure: Ordering information • In table: Absolute maximum ratings : <ul style="list-style-type: none"> • Added footnote to I_{INJPAD_DC} • Updated min and max value of I_{INJPAD_DC} • Updated description, max and min values for I_{INJSUM} • Updated $V_{IN_TRANSIENT}$ • In table: Voltage and current operating requirements : <ul style="list-style-type: none"> • Renamed V_{SUP_OFF} • Updated max value of V_{DD_OFF} • Removed V_{INA} and V_{IN} • Added V_{REFH} and V_{REFL} • Updated footnote "Typical conditions assumes $V_{DD} = V_{DDA} = V_{REFH} = 5$ V ..." • Removed I_{NJSUM_AF} • Updated footnotes in table Table 4 • Updated section Power mode transition operating behaviors • In table: Power consumption <ul style="list-style-type: none"> • Added footnote "With PMC_REGSC[CLKBIASDIS] ... " • Updated conditions for VLPR • Removed Idd/MHz for S32K144 • Updated numbers for S32K142 and S32K148 • Removed use case footnotes • In section Modes configuration : <ul style="list-style-type: none"> • Replaced table "Modes configuration" with spreadsheet attachment: 'S32K1xx_Power_Modes_Master_configuration_sheet' • In table: DC electrical specifications at 3.3 V Range : <ul style="list-style-type: none"> • Added footnotes to V_{ih} Input Buffer High Voltage and V_{ih} Input Buffer Low Voltage • Added footnote to High drive port pins • In table: DC electrical specifications at 5.0 V Range : |

Table continues on the next page...

Table 40. Revision History

| Rev. No. | Date | Substantial Changes |
|----------|------|--|
| | | <ul style="list-style-type: none"> • Added footnotes V_{ih} Input Buffer High Voltage and V_{ih} Input Buffer Low Voltage • Updated table: AC electrical specifications at 3.3 V range • Updated table: AC electrical specifications at 5 V range • In table: Standard input pin capacitance <ul style="list-style-type: none"> • Added footnote to Normal run mode (S32K14x series) • Removed note from 1M ohms Feedback Resistor in figure Oscillator connections scheme • In table: External System Oscillator electrical specifications <ul style="list-style-type: none"> • Updated typical of I_{DDOSC} Supply current — low-gain mode (low-power mode) (HGO=0) 1 for 4 and 8 MHz • Removed rows for I_{lk_ext} EXTAL/XTAL impedance High-frequency, low-gain mode (low-power mode) and high-frequency, high-gain mode and V_{EXTAL} • Updated Typ. of R_S low-gain mode • Updated description of R_F, R_S, and V_{PP} • Removed footnote from R_F Feedback resistor • Updated footnote for C_1 C_2 and R_F • In table: Table 16 <ul style="list-style-type: none"> • Removed mention of high-frequency • Added HGO 0, 1 information • In table: Fast internal RC Oscillator electrical specifications <ul style="list-style-type: none"> • Updated F_{FIRC} • Updated description of ΔF • Updated typ and max values of T_{JIT} cycle-to-cycle jitter and T_{JIT} Long term jitter over 1000 cycles • Added footnotes to T_{JIT} cycle-to-cycle jitter and T_{JIT} Long term jitter over 1000 cycles • Updated naming convention of I_{DDFIRC} Supply current • Added footnote to I_{DDFIRC} Supply current • Added footnote to column Parameter • In table: Slow internal RC oscillator (SIRC) electrical specifications <ul style="list-style-type: none"> • Removed V_{DD} Supply current in 2 MHz Mode • Removed footnote and updated description of ΔF • Updated footnote to F_{SIRC} and I_{DSSIRC} • In table: SPLL electrical specifications <ul style="list-style-type: none"> • Added row for F_{SPLL_REF} PLL Reference • Updated naming convention throughout the table • Updated the max value of T_{SPLL_LOCK} Lock detector detection time • In table: Table 21 <ul style="list-style-type: none"> • Added footnotes: <ul style="list-style-type: none"> • All command times assumes ... • For all EEPROM Emulation terms ... • 'First time' EERAM writes after a POR ... • Removed footnote 'Assumes 25 MHz or ...' • Updated Max of $t_{eewr32bers}$ • Added parameters $t_{quickwr}$ and $t_{quickwrCinup}$ • In table: Table 22 <ul style="list-style-type: none"> • Removed Typ. values for all parameters • Removed footnote 'Typical values represent ...' • Added footnote 'Any other EEE driver usage ...' • Updated QuadSPI AC specifications • Removed topic: Reliability, Safety and Security modules • In table: 12-bit ADC operating conditions <ul style="list-style-type: none"> • Updated V_{DDA} |

Table continues on the next page...

Table 40. Revision History (continued)

| Rev. No. | Date | Substantial Changes |
|----------|---------------|---|
| | | <ul style="list-style-type: none"> • Updated values for V_{REFH} and V_{REFL} to add reference to the section "voltage and current operating requirements" for Min and Max values • Updated footnote to Typ. • Removed footnote from RAS Analog source resistance • Updated figure: ADC input impedance equivalency diagram • In table: 12-bit ADC characteristics (2.7 V to 3 V) ($V_{REFH} = V_{DDA}$, $V_{REFL} = V_{SS}$) <ul style="list-style-type: none"> • Removed rows for V_{TEMP_S} and V_{TEMP25} • Updated footnote to Typ. • In table: 12-bit ADC characteristics (3 V to 5.5 V) ($V_{REFH} = V_{DDA}$, $V_{REFL} = V_{SS}$) <ul style="list-style-type: none"> • Removed rows for V_{TEMP_S} and V_{TEMP25} • Removed number for TUE • Updated footnote to Typ. • In table: Comparator with 8-bit DAC electrical specifications <ul style="list-style-type: none"> • Updated Typ. of I_{DDL5} Supply current, Low-speed mode • Updated Typ. of t_{DL5B} Propagation delay, Low-speed mode • Updated Typ. of t_{DH5S} Propagation delay, High-speed mode • Updated t_{DL5S} Propagation delay • Added row for t_{DDAC} Initialization and switching settling time • Updated footnote • Updated section LPSPI electrical specifications • Added section: SAI electrical specifications • Updated section: Ethernet AC specifications • Added section: Clockout frequency • Added section: Trace electrical specifications • Updated table: Table 38 : Updated numbers for S32K142 and S32K148 • Updated table: Table 39 : Updated numbers for S32K148 • Updated Document number for 32-pin QFN in topic Obtaining package dimensions |
| 3 | 14 March 2017 | <ul style="list-style-type: none"> • In Table 2 <ul style="list-style-type: none"> • Updated min. value of V_{DD_OFF} • Added parameter $I_{INJ_SUM_AF}$ • Updated Power mode transition operating behaviors • Updated Power consumption • Updated footnote to T_{SPLL_LOCK} in SPLL electrical specifications • In 12-bit ADC electrical characteristics <ul style="list-style-type: none"> • Updated table: 12-bit ADC characteristics (2.7 V to 3 V) ($V_{REFH} = V_{DDA}$, $V_{REFL} = V_{SS}$) <ul style="list-style-type: none"> • Added typ. value to I_{DDA_ADC}, TUE, DNL, and INL • Added min. value to SMPLTS • Removed footnote 'All the parameters in this table ... ' • Updated table: 12-bit ADC characteristics (3 V to 5.5 V) ($V_{REFH} = V_{DDA}$, $V_{REFL} = V_{SS}$) <ul style="list-style-type: none"> • Added typ. value to I_{DDA_ADC} • Removed footnote 'All the parameters in this table ... ' • In Table 21 updated Max. value of t_{vfykey} to 33 μs |
| 4 | 02 June 2017 | <ul style="list-style-type: none"> • In section: Block diagram, added block diagram for S32K11x series. • Updated figure: S32K1xx product series comparison. • In section: Determining valid orderable parts , added reference to attachment S32K_Part_Numbers.xlsx. • In section: Ordering information <ul style="list-style-type: none"> • Updated figure: Ordering information. • In Table 1, |

Table 40. Revision History

| Rev. No. | Date | Substantial Changes |
|----------|------|--|
| | | <ul style="list-style-type: none"> • Updated note 'All the limits defined ...' • Updated parameter 'I_{INJPAD_DC_ABS}', 'V_{IN_DC}', I_{INJSUM_DC_ABS}. • In Table 2, <ul style="list-style-type: none"> • Updated parameter I_{INJPAD_DC_OP} and I_{INJSUM_DC_OP}. • In Table 5, updated TBDs for V_{LVR_HYST}, V_{LVD_HYST}, and V_{LVW_HYST} • In Table 6, <ul style="list-style-type: none"> • Added VLPR → VLPS • Added VLPS → VLPR • Updated TBDs for VLPS → Asynchronous DMA Wakeup, STOP1 → Asynchronous DMA Wakeup, and STOP2 → Asynchronous DMA Wakeup • In Table 7, updated the specifications for S32K144. • Updated the attachment <i>S32K1xx_Power_Modes_Configuration.xlsx</i>. • In Table 13, removed C_{IN_A}. • In Table 15, <ul style="list-style-type: none"> • Updated specificatins for g_{mXOSC}. • Removed I_{DDOSC} • In Table 17, <ul style="list-style-type: none"> • Added parameter ΔF125. • Removed I_{DDFIRC} • In Table 18, <ul style="list-style-type: none"> • Added parameter ΔF125. • Removed I_{DDSIRC} • In Table 19, removed I_{LPO} • Updated section: Flash memory module (FTFC) electrical specifications • In section: 12-bit ADC operating conditions, <ul style="list-style-type: none"> • Updated TBDs for I_{DDA_ADC} and TUE in Table 25 • Updated TBDs for I_{DDA_ADC} and TUE in Table 26 • In section: QuadSPI AC specifications, updated figure 'QuadSPI output timing (HyperRAM mode) diagram'. • In section: 12-bit ADC operating conditions, updated Table 24. • In section: CMP with 8-bit DAC electrical specifications, added note 'For comparator IN signals adjacent ...' • In table: Table 29, minor update in footnote 6. • In table: Table 38, updated specifications for S32K146. |

How to Reach Us:**Home Page:**nxp.com**Web Support:**nxp.com/support

Information in this document is provided solely to enable system and software implementers to use NXP products. There are no express or implied copyright licenses granted hereunder to design or fabricate any integrated circuits based on the information in this document. NXP reserves the right to make changes without further notice to any products herein.

NXP makes no warranty, representation, or guarantee regarding the suitability of its products for any particular purpose, nor does NXP assume any liability arising out of the application or use of any product or circuit, and specifically disclaims any and all liability, including without limitation consequential or incidental damages. "Typical" parameters that may be provided in NXP data sheets and/or specifications can and do vary in different applications, and actual performance may vary over time. All operating parameters, including "typicals," must be validated for each customer application by customer's technical experts. NXP does not convey any license under its patent rights nor the rights of others. NXP sells products pursuant to standard terms and conditions of sale, which can be found at the following address: nxp.com/SalesTermsandConditions.

NXP, the NXP logo, NXP SECURE CONNECTIONS FOR A SMARTER WORLD, COOLFLUX, EMBRACE, GREENCHIP, HITAG, I2C BUS, ICODE, JCOP, LIFE VIBES, MIFARE, MIFARE CLASSIC, MIFARE DESFire, MIFARE PLUS, MIFARE FLEX, MANTIS, MIFARE ULTRALIGHT, MIFARE4MOBILE, MIGLO, NTAG, ROADLINK, SMARTLX, SMARTMX, STARPLUG, TOPFET, TRENCHMOS, UCODE, Freescale, the Freescale logo, AltiVec, C-5, CodeTest, CodeWarrior, ColdFire, ColdFire+, C-Ware, the Energy Efficient Solutions logo, Kinetis, Layerscape, MagniV, mobileGT, PEG, PowerQUICC, Processor Expert, QorIQ, QorIQ Qonverge, Ready Play, SafeAssure, the SafeAssure logo, StarCore, Symphony, VortiQa, Vybrid, Airfast, BeeKit, BeeStack, CoreNet, Flexis, MXC, Platform in a Package, QUICC Engine, SMARTMOS, Tower, TurboLink, and UMEMS are trademarks of NXP B.V. All other product or service names are the property of their respective owners. ARM, AMBA, ARM Powered, Artisan, Cortex, Jazelle, Keil, SecurCore, Thumb, TrustZone, and μ Vision are registered trademarks of ARM Limited (or its subsidiaries) in the EU and/or elsewhere. ARM7, ARM9, ARM11, big.LITTLE, CoreLink, CoreSight, DesignStart, Mali, mbed, NEON, POP, Sensinode, Socrates, ULINK and Versatile are trademarks of ARM Limited (or its subsidiaries) in the EU and/or elsewhere. All rights reserved. Oracle and Java are registered trademarks of Oracle and/or its affiliates. The Power Architecture and Power.org word marks and the Power and Power.org logos and related marks are trademarks and service marks licensed by Power.org.

© 2015–2017 NXP B.V.

Document Number S32K1XX
Revision 4, 06/2017



Looking for pricing, stock, or lifecycle information?

Click below to explore more details on WIN SOURCE:

- ⊖ [View FS32K146HRT0CLLT on WIN SOURCE](#)
- ⊖ [NXP / Nexperia Information](#)

Optimize Your Supply Chain with WIN SOURCE Solutions

- ✓ Global Sourcing Solution
- ✓ Obsolete Management
- ✓ Cost Control Management
- ✓ Shortage Management
- ✓ Alternative Solution
- ✓ Excess Inventory Management