



**THE DATASHEET OF
FOD4216SV**



6-Pin DIP High dv/dt Random Phase Triac Drivers

FOD420, FOD4208, FOD4216, FOD4218

Description

The FOD420, FOD4208, FOD4216 and FOD4218 devices consist of an infrared emitting diode coupled to a hybrid random phase triac formed with two inverse parallel SCRs which form the triac function capable of driving discrete triacs. The FOD4216 and FOD4218 utilize a high efficiency infrared emitting diode which offers an improved trigger sensitivity. These devices are housed in a standard 6-pin dual in-line (DIP) package.

Features

- 300 mA_{peak} On-State Current
- High Blocking Voltage
 - ◆ 600 V (FOD420, FOD4216)
 - ◆ 800 V (FOD4208, FOD4218)
- High Trigger Sensitivity
 - ◆ 1.3 mA (FOD4216, FOD4218)
 - ◆ 2 mA (FOD420, FOD4208)
- High Static dv/dt (10,000 V/μs)
- Safety and Regulatory Approvals:
 - ◆ UL1577, 5,000 VAC_{RMS} for 1 Minute
 - ◆ DIN-EN/IEC60747-5-5
- These Devices are Pb-Free and are RoHS Compliant

Applications

- Solid-State Relays
- Industrial Controls
- Lighting Controls
- Static Power Switches
- AC Motor Starters



ON Semiconductor®

www.onsemi.com

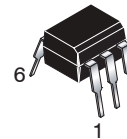

PDIP6 GW
CASE 709AG

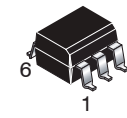

PDIP6 7.3x6.5, 2.54P
CASE 646CE

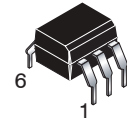

PDIP6 7.3x6.5, 2.54P
CASE 646CF

MARKING DIAGRAM

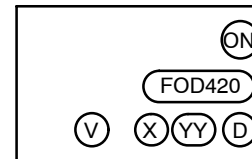

- ON = ON Semiconductor Logo
- FOD420 = Device Number
- V = VDE mark. DIN EN/IEC60747-5-5 Option (only appears on component ordered with this option)
- X = One-Digit Year Code
- YY = Digit Work Week
- D = Assembly Package Code

FUNCTIONAL SCHEMATIC

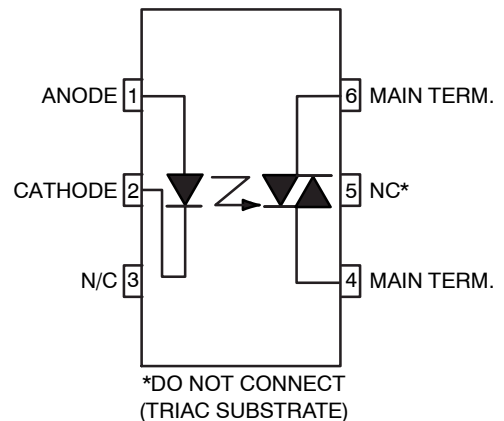

ORDERING INFORMATION

See detailed ordering and shipping information on page 8 of this data sheet.

SAFETY AND INSULATION RATINGS

Parameter		Characteristics
Installation Classifications per DIN VDE 0110/1.89 Table 1, For Rated Mains Voltage	< 150 V _{RMS}	I-IV
	< 300 V _{RMS}	I-IV
Climatic Classification		55/100/21
Pollution Degree (DIN VDE 0110/1.89)		2
Comparative Tracking Index		175

Symbol	Parameter	Value	Unit
V _{PR}	Input-to-Output Test Voltage, Method A, V _{IORM} × 1.6 = V _{PR} , Type and Sample Test with t _m = 10 s, Partial Discharge < 5 pC	1360	V _{peak}
	Input-to-Output Test Voltage, Method B, V _{IORM} × 1.875 = V _{PR} , 100% Production Test with t _m = 1 s, Partial Discharge < 5 pC	1594	V _{peak}
V _{IORM}	Maximum Working Insulation Voltage	850	V _{peak}
V _{IOTM}	Highest Allowable Over-Voltage	6000	V _{peak}
	External Creepage	≥7	mm
	External Clearance	≥7	mm
DTI	Distance Through Insulation (Insulation Thickness)	≥0.4	mm
T _S	Case Temperature (Note 1)	175	°C
I _{S,INPUT}	Input Current (Note 1)	400	mA
P _{S,OUTPUT}	Output Power (Note 1)	700	mW
R _{IO}	Insulation Resistance at T _S , V _{IO} = 500 V (Note 1)	>10 ⁹	Ω

As per DIN EN/IEC 60747-5-5, this optocoupler is suitable for “safe electrical insulation” only within the safety limit data. Compliance with the safety ratings shall be ensured by means of protective circuits.

1. Safety limit values – maximum values allowed in the event of a failure.

FOD420, FOD4208, FOD4216, FOD4218

ABSOLUTE MAXIMUM RATINGS (T_A = 25°C, unless otherwise specified)

Symbol	Parameter	Device	Value	Unit
T _{STG}	Storage Temperature	All	-55 to +150	°C
T _{OPR}	Operating Temperature	All	-55 to +100	°C
T _J	Junction Temperature	All	-55 to +125	°C
T _{SOL}	Lead Solder Temperature	All	260 for 10 sec	°C
P _{D(TOTAL)}	Total Device Power Dissipation @ 25°C	All	500	mW
	Derate Above 25°C	All	6.6	mW/°C

EMITTER

I _F	Continuous Forward Current	All	30	mA
V _R	Reverse Voltage	All	6	V
P _{D(EMITTER)}	Total Power Dissipation 25°C Ambient	All	50	mW
	Derate Above 25°C	All	0.71	mW/°C

DETECTOR

V _{DRM}	Off-State Output Terminal Voltage	FOD420, FOD4216	600	V
		FOD4208, FOD4218	800	
I _{TSM}	Peak Non-Repetitive Surge Current (single cycle 60 Hz sine wave)	All	3	A _{peak}
I _{TM}	Peak On-State Current	All	300	mA _{peak}
P _{D(DETECTOR)}	Total Power Dissipation @ 25°C Ambient	All	450	mW
P _{D(DETECTOR)}	Derate Above 25°C	All	5.9	mW/°C

Stresses exceeding those listed in the Maximum Ratings table may damage the device. If any of these limits are exceeded, device functionality should not be assumed, damage may occur and reliability may be affected.

FOD420, FOD4208, FOD4216, FOD4218

ELECTRICAL CHARACTERISTICS (T_A = 25°C unless otherwise specified)

Symbol	Parameter	Test Condition	Device	Min	Typ	Max	Unit
--------	-----------	----------------	--------	-----	-----	-----	------

INDIVIDUAL COMPONENT CHARACTERISTICS

Emitter								
V _F	Input Forward Voltage	I _F = 20 mA	All	–	1.28	1.50	V	
I _R	Reverse Leakage Current	V _R = 6 V	All	–	0.01	10	μA	
Detector								
I _{D(RMS)}	Peak Blocking Current, Either Direction	I _F = 0, T _A = 100°C (Note 2)	V _D = 600 V	FOD420, FOD4216	–	3	100	μA
			V _D = 800 V	FOD4208, FOD4218				
I _{R(RMS)}	Reverse Current	T _A = 100°C	V _D = 600 V	FOD420, FOD4216	–	3	100	μA
			V _D = 800 V	FOD4208, FOD4218				
dv/dt	Critical Rate of Rise of Off-State Voltage	I _F = 0 A (Note 3)	V _D = V _{DRM}	All	10,000	–	–	V/μs

TRANSFER CHARACTERISTICS

I _{FT}	LED Trigger Current	Main Terminal Voltage = 5 V (Note 4)		FOD420, FOD4208	–	0.75	2.0	mA
				FOD4216, FOD4218	–	0.75	1.3	
V _{TM}	Peak On-State Voltage, Either Direction	I _{TM} = 300 mA peak, I _F = Rated I _{FT}		All	–	2.2	3	V
I _H	Holding Current, Either Direction	V _T = 3 V		All	–	200	500	μA
I _L	Latching Current	V _T = 2.2 V		All	–	5	–	mA
t _{ON}	Turn-On Time	PF = 1.0, I _T = 300 mA	V _{RM} = V _{DM} = 424 VAC	FOD420, FOD4216, FOD4218	–	60	–	μs
			V _{RM} = V _{DM} = 565 VAC	FOD4208				
t _{OFF}	Turn-Off Time		V _{RM} = V _{DM} = 424 VAC	FOD420, FOD4216, FOD4218	–	52	–	μs
			V _{RM} = V _{DM} = 565 VAC	FOD4208				
dv/dt _C	Critical Rate of Rise of Voltage at Current Commutation	V _D = 230 V _{RMS} , I _D = 300 mA _{PK}		All	–	10	–	V/μs
di/dt _C	Critical Rate of Rise of On-State Current Commutation	V _D = 230 V _{RMS} , I _D = 300 mA _{PK}		All	–	9	–	A/ms
dv(I _O)/dt	Critical Rate of Rise of Coupled Input / Output Voltage	I _T = 0 A, V _{RM} = V _{DM} = 424 VAC		All	10,000	–	–	V/μs

ISOLATION CHARACTERISTICS

V _{ISO}	Steady State Isolation Voltage	f = 60 Hz, t = 1 Minute (Note 5)	All	5,000	–	–	VAC _{RMS}
------------------	--------------------------------	----------------------------------	-----	-------	---	---	--------------------

Product parametric performance is indicated in the Electrical Characteristics for the listed test conditions, unless otherwise noted. Product performance may not be indicated by the Electrical Characteristics if operated under different conditions.

- Test voltage must be applied within dv/dt rating.
- This is static dv/dt. Commutating dv/dt is a function of the load-driving thyristor(s) only.
- All devices are guaranteed to trigger at an I_F value less than or equal to max I_{FT}. Therefore, recommended operating I_F lies between max I_{FT} (2 mA for FOD420 and FOD4208 and 1.3 mA for FOD4216 and FOD4218) and the absolute max I_F (30 mA).
- Isolation voltage, V_{ISO}, is an internal device dielectric breakdown rating. For this test, pins 1, 2 and 3 are common, and pins 4, 5 and 6 are common. 5,000 VAC_{RMS} for 1 minute duration is equivalent to 6,000 VAC_{RMS} for 1 second duration.

FOD420, FOD4208, FOD4216, FOD4218

TYPICAL APPLICATION

Figure 1 shows a typical circuit for when hot line switching is required. In this circuit the “hot” side of the line is switched and the load connected to the cold or neutral side. The load may be connected to either the neutral or hot line.

R_{in} is calculated so that IF is equal to the rated IFT of the

part, 2 mA for FOD420 and FOD4208, 1.3 mA for FOD4216 and FOD4218. The 39 Ω resistor and 0.01 μ F capacitor are for snubbing of the triac and may or may not be necessary depending upon the particular triac and load use.

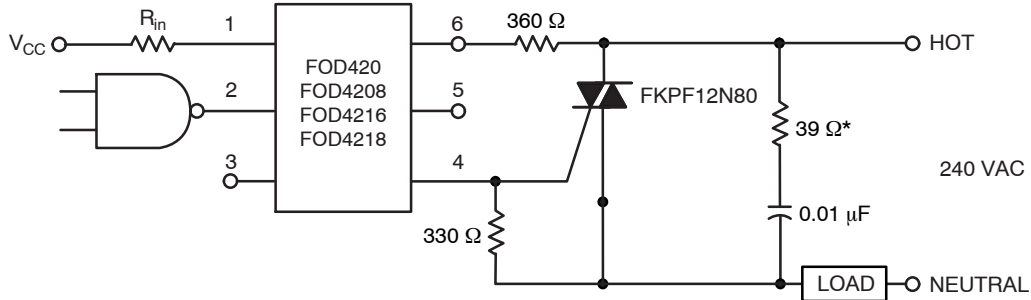

*For highly inductive loads (power factor < 0.5), change this value to 360 Ω .

Figure 1. Hot-Line Switching Application Circuit

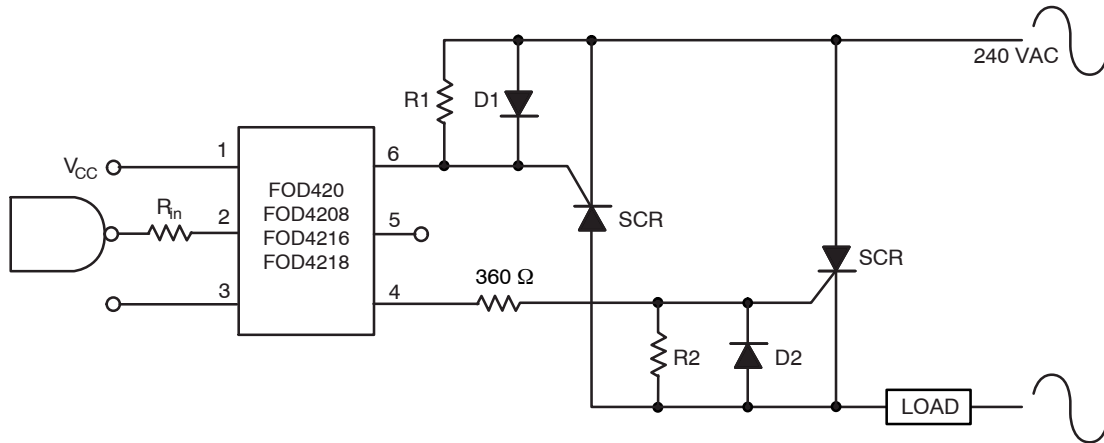

Figure 2. Inverse-Parallel SCR Driver Circuit

Suggested method of firing two, back-to-back SCR's with On Semiconductor triac driver. Diodes can be 1N4001; resistors, R1 and R2, are optional 330 Ω .

NOTE: This optoisolator should not be used to drive a load directly. It is intended to be a discrete triac driver device only.

TYPICAL CHARACTERISTICS

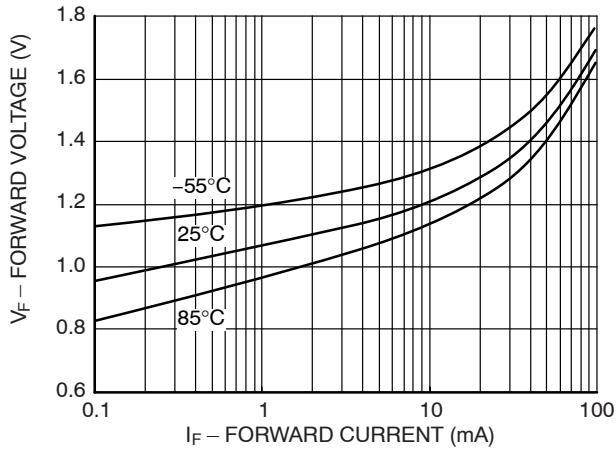

Figure 3. Forward Voltage (V_F) vs. Forward Current (I_F)

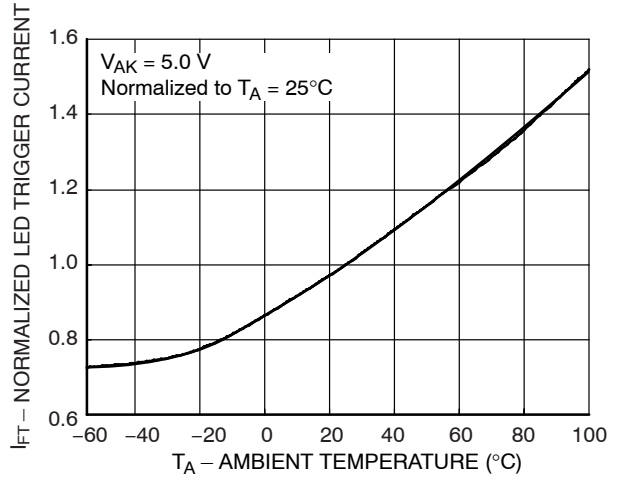

Figure 4. Normalized LED Trigger Current (I_{FT}) vs. Ambient Temperature (T_A)

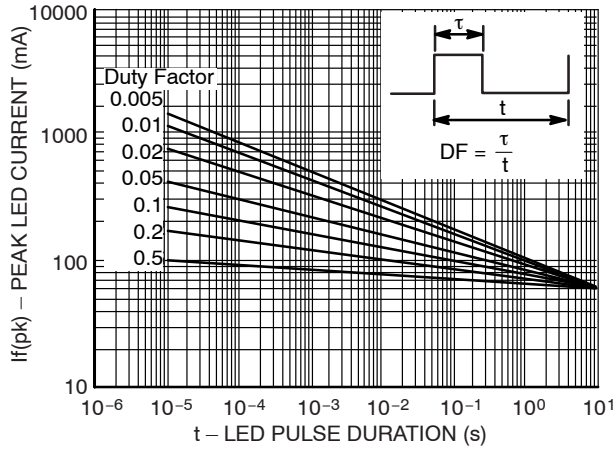

Figure 5. Peak LED Current vs. Duty Factor, Tau

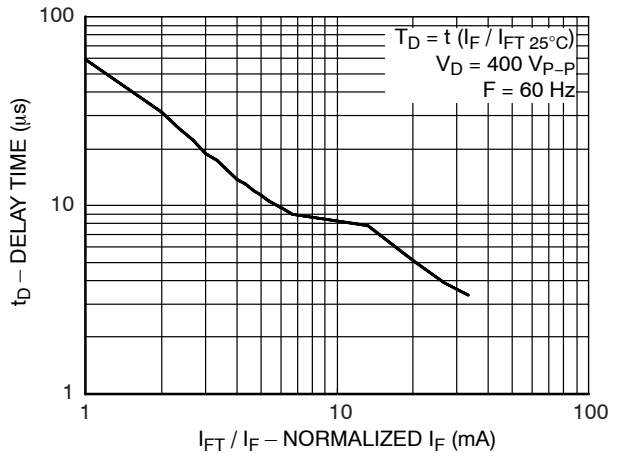

Figure 6. Trigger Delay Time

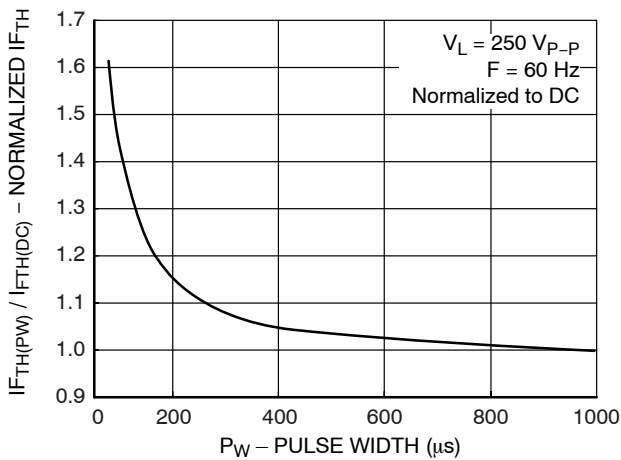

Figure 7. Pulse Trigger Current

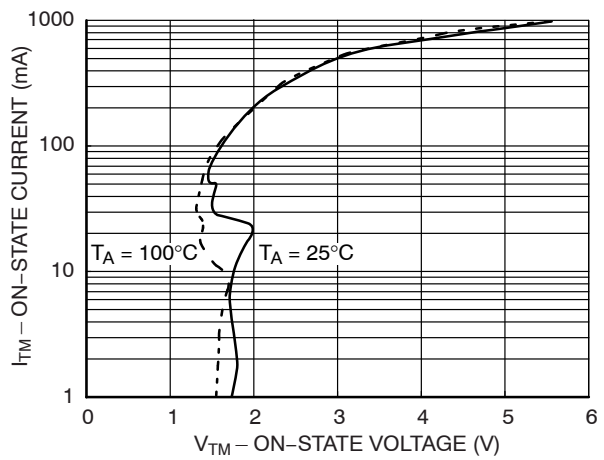

Figure 8. On-State Voltage (V_{TM}) vs. On-State Current (I_{TM})

TYPICAL CHARACTERISTICS (continued)

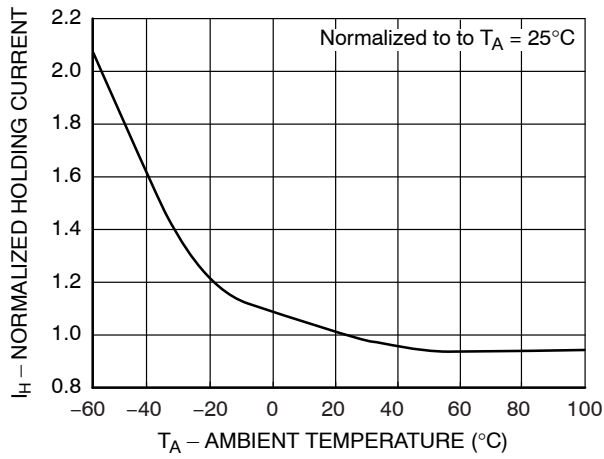

Figure 9. Normalized Holding Current (I_H) vs. Ambient Temperature (T_A)

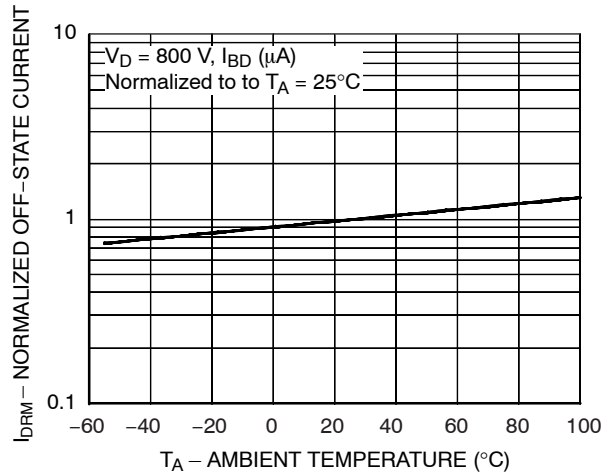

Figure 10. Normalized Off-State Current (I_{DRM}) vs. Ambient Temperature (T_A)

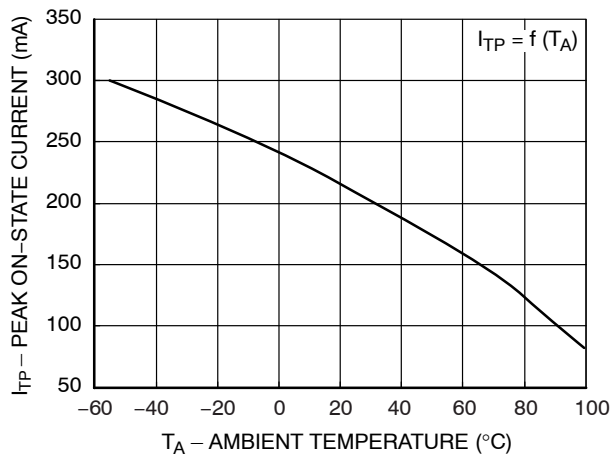
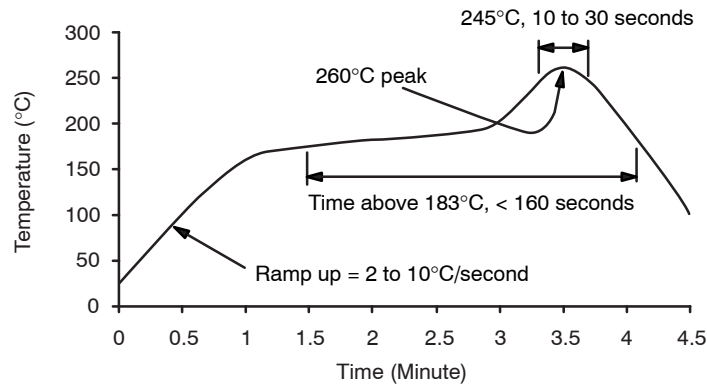

Figure 11. Current Reduction

REFLOW PROFILE



- Peak reflow temperature: 262°C (package surface temperature)
- Time of temperature higher than 183°C for 160 seconds or less
- One time soldering reflow is recommended

Figure 12. Reflow Profile

ORDERING INFORMATION

Part Number	Package	Shipping†
FOD420	DIP 6-Pin	50 Units / Tube
FOD420S	SMT 6-Pin (Lead Bend)	50 Units / Tube
FOD420SD	SMT 6-Pin (Lead Bend)	1000 / Tape & Reel
FOD420V	DIP 6-Pin, DIN EN/IEC60747-5-5 Option	50 Units / Tube
FOD420SV	SMT 6-Pin (Lead Bend), DIN EN/IEC60747-5-5 Option	50 Units / Tube
FOD420SDV	SMT 6-Pin (Lead Bend), DIN EN/IEC60747-5-5 Option	1000 / Tape & Reel
FOD420TV	DIP 6-Pin, 0.4" Lead Spacing, DIN EN/IEC60747-5-5 Option	50 Units / Tube

†For information on tape and reel specifications, including part orientation and tape sizes, please refer to our Tape and Reel Packaging Specifications Brochure, BRD8011/D.

6. The product orderable part number system listed in this table also applies to the FOD4208, FOD4216, and FOD4218 product families.

MECHANICAL CASE OUTLINE
PACKAGE DIMENSIONS

ON Semiconductor®



PDIP6 7.3x6.5, 2.54P
CASE 646CE
ISSUE O

DATE 31 JUL 2016

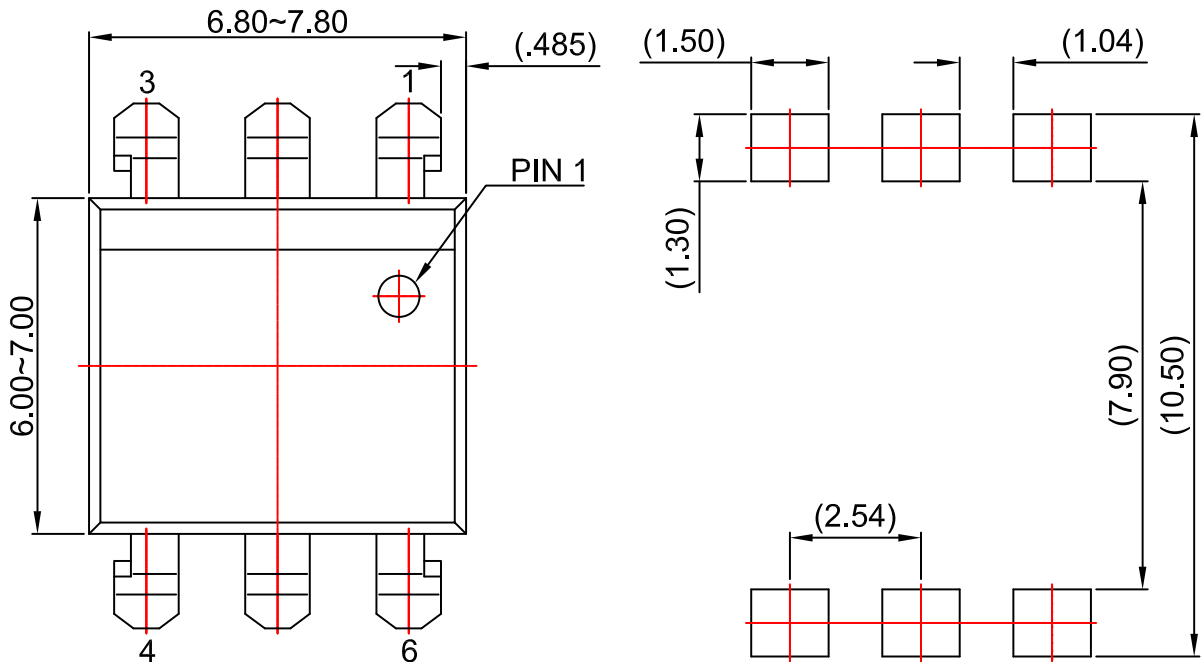

LAND PATTERN RECOMMENDATION

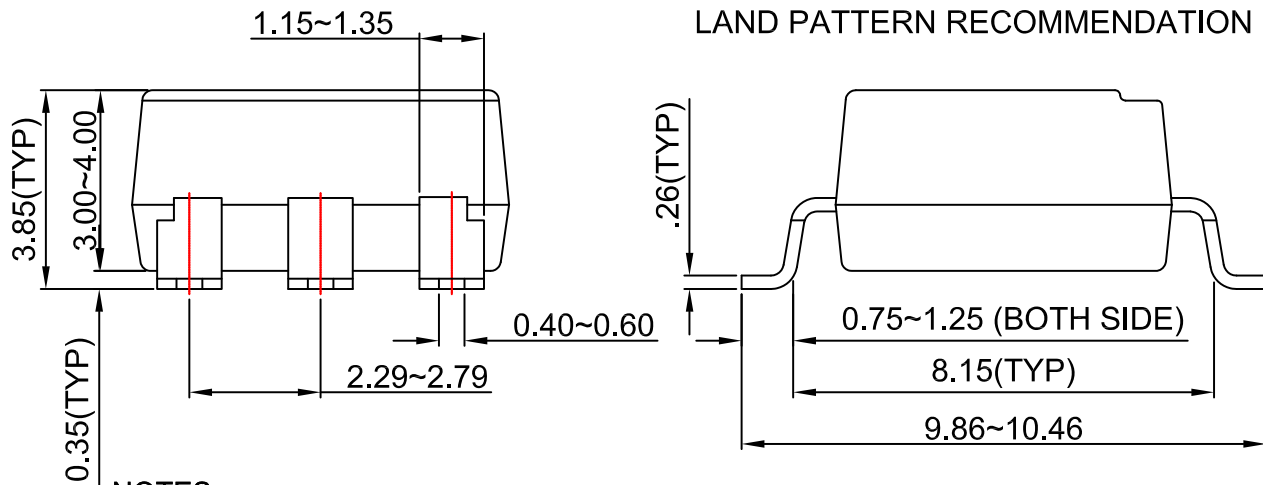

NOTES:

- A) NO STANDARD APPLIES TO THIS PACKAGE.
- B) ALL DIMENSIONS ARE IN MILLIMETERS.
- C) DIMENSIONS ARE EXCLUSIVE OF BURRS, MOLD FLASH, AND TIE BAR EXTRUSION

DOCUMENT NUMBER:	98AON13456G	Electronic versions are uncontrolled except when accessed directly from the Document Repository. Printed versions are uncontrolled except when stamped "CONTROLLED COPY" in red.
DESCRIPTION:	PDIP6 7.3X6.5, 2.54P	PAGE 1 OF 1

ON Semiconductor and are trademarks of Semiconductor Components Industries, LLC dba ON Semiconductor or its subsidiaries in the United States and/or other countries. ON Semiconductor reserves the right to make changes without further notice to any products herein. ON Semiconductor makes no warranty, representation or guarantee regarding the suitability of its products for any particular purpose, nor does ON Semiconductor assume any liability arising out of the application or use of any product or circuit, and specifically disclaims any and all liability, including without limitation special, consequential or incidental damages. ON Semiconductor does not convey any license under its patent rights nor the rights of others.

MECHANICAL CASE OUTLINE
PACKAGE DIMENSIONS



PDIP6 7.3x6.5, 2.54P
CASE 646CF
ISSUE O

DATE 31 JUL 2016

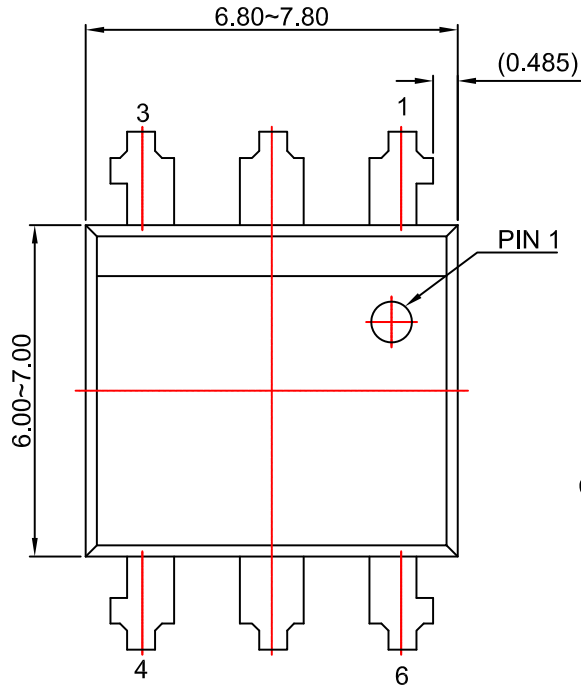

NOTES:

- A) NO STANDARD APPLIES TO THIS PACKAGE.
- B) ALL DIMENSIONS ARE IN MILLIMETERS.
- C) DIMENSIONS ARE EXCLUSIVE OF BURRS, MOLD FLASH, AND TIE BAR EXTRUSION

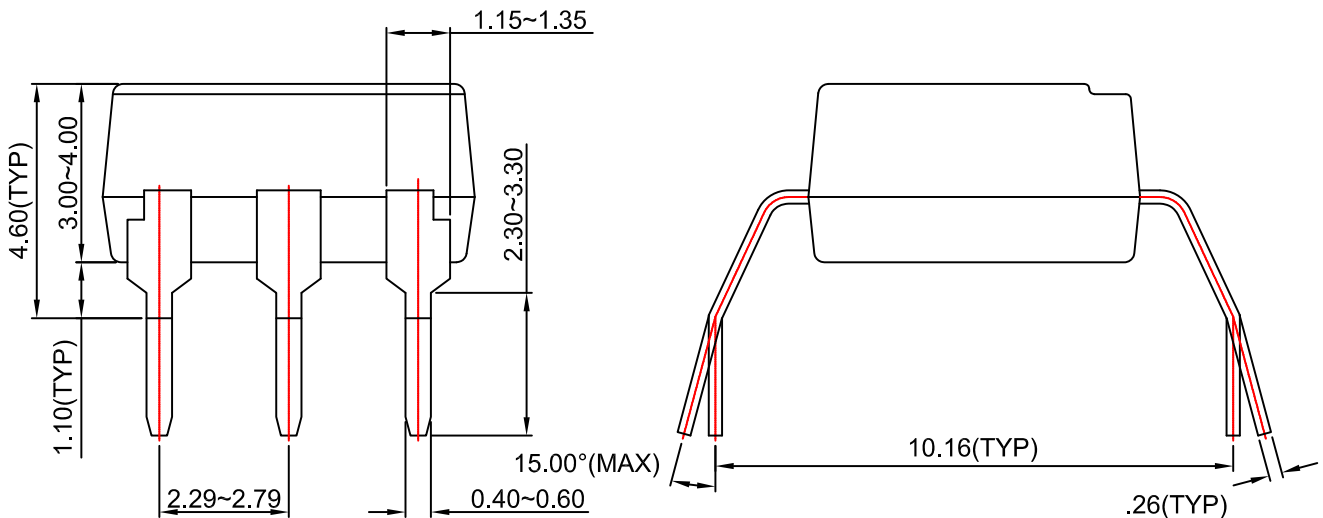

DOCUMENT NUMBER:	98AON13457G	Electronic versions are uncontrolled except when accessed directly from the Document Repository. Printed versions are uncontrolled except when stamped "CONTROLLED COPY" in red.
DESCRIPTION:	PDIP6 7.3X6.5, 2.54P	PAGE 1 OF 1

ON Semiconductor and are trademarks of Semiconductor Components Industries, LLC dba ON Semiconductor or its subsidiaries in the United States and/or other countries. ON Semiconductor reserves the right to make changes without further notice to any products herein. ON Semiconductor makes no warranty, representation or guarantee regarding the suitability of its products for any particular purpose, nor does ON Semiconductor assume any liability arising out of the application or use of any product or circuit, and specifically disclaims any and all liability, including without limitation special, consequential or incidental damages. ON Semiconductor does not convey any license under its patent rights nor the rights of others.

MECHANICAL CASE OUTLINE

PACKAGE DIMENSIONS

ON Semiconductor®



PDIP6 GW
CASE 709AG
ISSUE A

DATE 31 JUL 2016

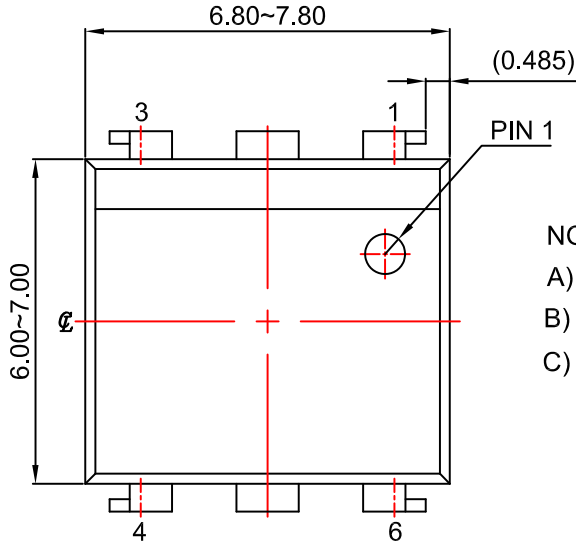

NOTES:

- A) NO STANDARD APPLIES TO THIS PACKAGE.
- B) ALL DIMENSIONS ARE IN MILLIMETERS.
- C) DIMENSIONS ARE EXCLUSIVE OF BURRS, MOLD FLASH, AND TIE BAR EXTRUSION

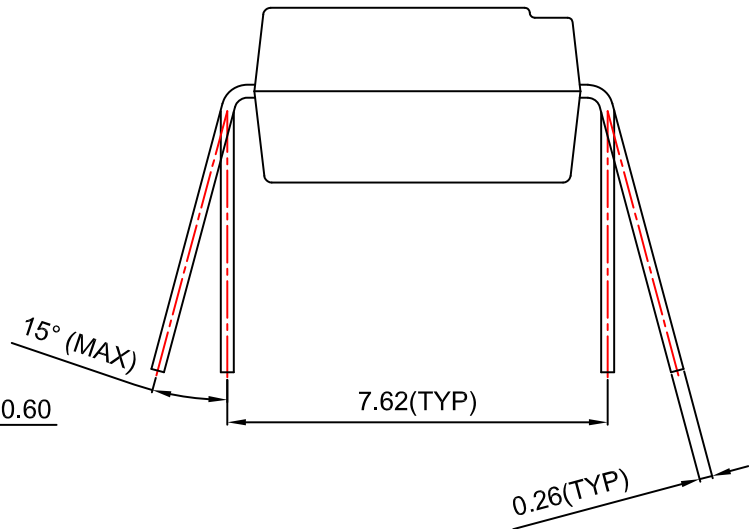
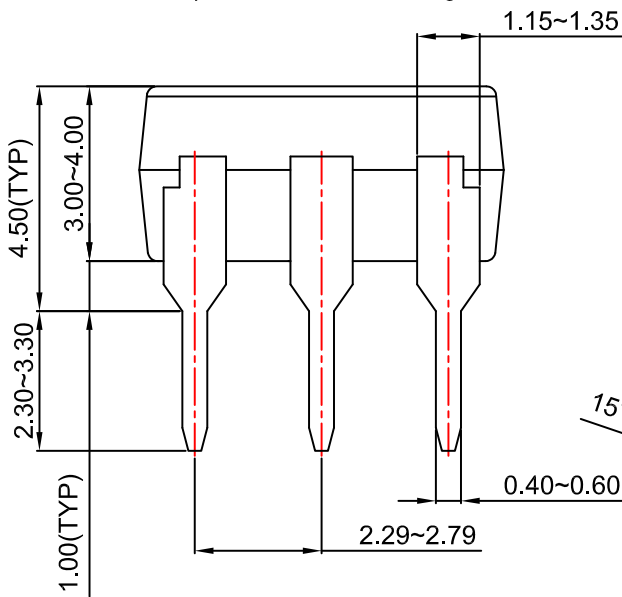

DOCUMENT NUMBER:	98AON13455G	Electronic versions are uncontrolled except when accessed directly from the Document Repository. Printed versions are uncontrolled except when stamped "CONTROLLED COPY" in red.
DESCRIPTION:	PDIP6 GW	PAGE 1 OF 1

ON Semiconductor and are trademarks of Semiconductor Components Industries, LLC dba ON Semiconductor or its subsidiaries in the United States and/or other countries. ON Semiconductor reserves the right to make changes without further notice to any products herein. ON Semiconductor makes no warranty, representation or guarantee regarding the suitability of its products for any particular purpose, nor does ON Semiconductor assume any liability arising out of the application or use of any product or circuit, and specifically disclaims any and all liability, including without limitation special, consequential or incidental damages. ON Semiconductor does not convey any license under its patent rights nor the rights of others.

onsemi, **Onsemi**, and other names, marks, and brands are registered and/or common law trademarks of Semiconductor Components Industries, LLC dba "**onsemi**" or its affiliates and/or subsidiaries in the United States and/or other countries. **onsemi** owns the rights to a number of patents, trademarks, copyrights, trade secrets, and other intellectual property. A listing of **onsemi**'s product/patent coverage may be accessed at www.onsemi.com/site/pdf/Patent-Marking.pdf. **onsemi** reserves the right to make changes at any time to any products or information herein, without notice. The information herein is provided "as-is" and **onsemi** makes no warranty, representation or guarantee regarding the accuracy of the information, product features, availability, functionality, or suitability of its products for any particular purpose, nor does **onsemi** assume any liability arising out of the application or use of any product or circuit, and specifically disclaims any and all liability, including without limitation special, consequential or incidental damages. Buyer is responsible for its products and applications using **onsemi** products, including compliance with all laws, regulations and safety requirements or standards, regardless of any support or applications information provided by **onsemi**. "Typical" parameters which may be provided in **onsemi** data sheets and/or specifications can and do vary in different applications and actual performance may vary over time. All operating parameters, including "Typicals" must be validated for each customer application by customer's technical experts. **onsemi** does not convey any license under any of its intellectual property rights nor the rights of others. **onsemi** products are not designed, intended, or authorized for use as a critical component in life support systems or any FDA Class 3 medical devices or medical devices with a same or similar classification in a foreign jurisdiction or any devices intended for implantation in the human body. Should Buyer purchase or use **onsemi** products for any such unintended or unauthorized application, Buyer shall indemnify and hold **onsemi** and its officers, employees, subsidiaries, affiliates, and distributors harmless against all claims, costs, damages, and expenses, and reasonable attorney fees arising out of, directly or indirectly, any claim of personal injury or death associated with such unintended or unauthorized use, even if such claim alleges that **onsemi** was negligent regarding the design or manufacture of the part. **onsemi** is an Equal Opportunity/Affirmative Action Employer. This literature is subject to all applicable copyright laws and is not for resale in any manner.

ADDITIONAL INFORMATION

TECHNICAL PUBLICATIONS:

Technical Library: www.onsemi.com/design/resources/technical-documentation
onsemi Website: www.onsemi.com

ONLINE SUPPORT: www.onsemi.com/support

For additional information, please contact your local Sales Representative at www.onsemi.com/support/sales

Looking for pricing, stock, or lifecycle information?

Click below to explore more details on WIN SOURCE:

 [View FOD4216SV](#) on WIN SOURCE

 [ON Semiconductor](#) Information

Optimize Your Supply Chain with WIN SOURCE Solutions

-  Global Sourcing Solution
-  Obsolete Management
-  Cost Control Management
-  Shortage Management
-  Alternative Solution
-  Excess Inventory Management