

3 A Output Current, High Speed MOSFET Gate Driver Optocoupler

FOD3182

Description

The FOD3182 is a 3 A Output Current, High Speed MOSFET Gate Drive Optocoupler. It consists of a aluminium gallium arsenide (AlGaAs) light emitting diode optically coupled to a CMOS detector with PMOS and NMOS output power transistors integrated circuit power stage. It is ideally suited for high frequency driving of power MOSFETS used in Plasma Display Panels (PDPs), motor control inverter applications and high performance DC/DC converters.

The device is packaged in an 8-pin dual in-line housing compatible with 260°C reflow processes for lead free solder compliance.

Features

- High Noise Immunity Characterized by 50 kV/μs (Typ.) Common Mode Rejection @ $V_{CM} = 2,000$ V
 - Guaranteed Operating Temperature Range of -40°C to +100°C
 - 3 A Peak Output Current
 - Fast Switching Speed
 - ◆ 210 ns Max. Propagation Delay
 - ◆ 65 ns Max. Pulse Width Distortion
 - Fast Output Rise/Fall Time
 - Offers Lower Dynamic Power Dissipation
 - 250 kHz Maximum Switching Speed
 - Wide V_{DD} operating Range: 10 V to 30 V
 - Use of P-Channel MOSFETs at Output Stage Enables Output Voltage Swing Close to the Supply Rail (Rail-to-Rail Output)
 - 5000 Vrms, 1 Minute Isolation
 - Under Voltage Lockout Protection (UVLO) with Hysteresis – Optimized for Driving MOSFETs
 - Minimum Creepage Distance of 8.0 mm
 - Minimum Clearance Distance of 10 mm to 16 mm (Option TV or TSV)
 - Minimum Insulation Thickness of 0.5 mm
 - UL and VDE*
 - 1,414 Peak Working Insulation Voltage (V_{IORM})
- *Requires “V” Ordering Option

Applications

- Plasma Display Panel
- High Performance DC/DC Converter
- High Performance Switch Mode Power Supply
- High Performance Uninterruptible Power Supply
- Isolated Power MOSFET Gate Drive

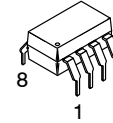

PDIP8 6.6x3.81, 2.54P
CASE 646BW

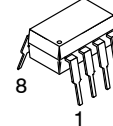

PDIP8 9.655x6.61, 2.54P
CASE 646CQ

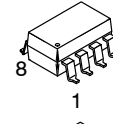

PDIP8 GW
CASE 709AC

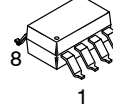

PDIP8 GW
CASE 709AD

MARKING DIAGRAM

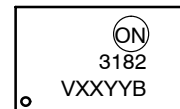

3182 = Device Number
V = VDE Mark (Note: Only appears on parts ordered with DIN EN/IEC 60747-5-2 option – See ordering table)
XX = Two Digit Year Code, e.g., “11”
YY = Digit Work Week Ranging from “01” to “53”
B = Assembly Package Code

FUNCTIONAL BLOCK DIAGRAM

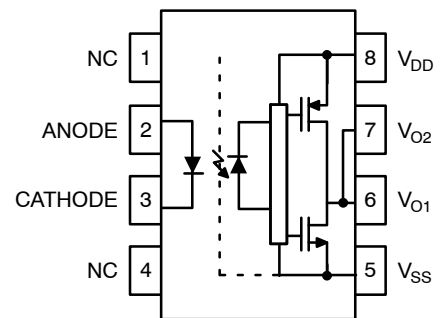

NOTE: A 0.1 μF bypass capacitor must be connected between pins 5 and 8.

ORDERING INFORMATION

See detailed ordering and shipping information on page 16 of this data sheet.

FOD3182

TRUTH TABLE

LED	V _{DD} – V _{SS} “Positive Going” (Turn-on)	V _{DD} – V _{SS} “Negative Going” (Turn-off)	V _O
Off	0 V to 30 V	0 V to 30 V	Low
On	0 V to 7.4 V	0 V to 7 V	Low
On	7.4 V to 9 V	7 V to 8.5 V	Transition
On	9 V to 30 V	8.5 V to 30 V	High

PIN DEFINITIONS

Pin No.	Name	Description
1	NC	Not Connected
2	Anode	LED Anode
3	Cathode	LED Cathode
4	NC	Not Connected
5	V _{SS}	Negative Supply Voltage
6	V _{O2}	Output Voltage 2 (internally connected to V _{O1})
7	V _{O1}	Output Voltage 1
8	V _{DD}	Positive Supply Voltage

SAFETY AND INSULATION RATINGS (As per DIN EN/IEC 60747–5–2. This optocoupler is suitable for “safe electrical insulation” only within the safety limit data. Compliance with the safety ratings shall be ensured by means of protective circuits.)

Symbol	Parameter	Min.	Typ.	Max.	Unit
	Installation Classifications per DIN VDE 0110/1.89 Table 1	–	I–IV	–	
	For Rated Mains Voltage < 150 Vrms				
	For Rated Mains Voltage < 300 Vrms				
	For Rated Mains Voltage < 450 Vrms				
	For Rated Mains Voltage < 600 Vrms				
	For Rated Mains Voltage < 1000 Vrms (Option T, TS)	–	I–III	–	
	Climatic Classification	–	40/100/21	–	
	Pollution Degree (DIN VDE 0110/1.89)	–	2	–	
CTI	Comparative Tracking Index	175	–	–	
V _{PR}	Input to Output Test Voltage, Method b, V _{IORM} × 1.875 = V _{PR} , 100% Production Test with t _m = 1 second, Partial Discharge < 5 pC	2651	–	–	
	Input to Output Test Voltage, Method a, V _{IORM} × 1.5 = V _{PR} , Type and Sample Test with t _m = 60 seconds, Partial Discharge < 5 pC	2121	–	–	
V _{IORM}	Max Working Insulation Voltage	1,414	–	–	V _{peak}
V _{IOTM}	Highest Allowable Over Voltage	6000	–	–	V _{peak}
	External Creepage	8	–	–	mm
	External Clearance	7.4	–	–	mm
	External Clearance (for Option T or TS – 0.4” Lead Spacing)	10.16	–	–	mm
	Insulation Thickness	0.5	–	–	mm
T _{Case}	Safety Limit Values – Maximum Values Allowed in the Event of a Failure Case Temperature	150	–	–	°C
I _{S,INPUT}	Input Current	25	–	–	mA
P _{S,OUTPUT}	Output Power (Duty Factor ≤ 2.7%)	250	–	–	mW
R _{IO}	Insulation Resistance at T _S , V _{IO} = 500 V	10 ⁹	–	–	Ω

FOD3182

ABSOLUTE MAXIMUM RATINGS (T_A = 25°C unless otherwise specified)

Symbol	Parameter	Value	Unit
T _{STG}	Storage Temperature	-40 to +125	°C
T _{OPR}	Operating Temperature	-40 to +100	°C
T _J	Junction Temperature	-40 to +125	°C
T _{SOL}	Lead Solder Temperature – Wave Solder (Refer to Reflow Temperature Profile, page 15)	260 for 10 seconds	°C
I _{F(AVG)}	Average Input Current (Note 1)	25	mA
I _{F(tr, tf)}	LED Current Minimum Rate of Rise/Fall	250	ns
V _R	Reverse Input Voltage	5	V
I _{OH(PEAK)}	“High” Peak Output Current (Note 2)	3	A
I _{OL(PEAK)}	“Low” Peak Output Current (Note 2)	3	A
V _{DD} – V _{SS}	Supply Voltage	-0.5 to 35	V
V _{O(PEAK)}	Output Voltage	0 to V _{DD}	V
P _O	Output Power Dissipation (Note 3)	250	mW
P _D	Total Power Dissipation (Note 4)	295	mW

Stresses exceeding those listed in the Maximum Ratings table may damage the device. If any of these limits are exceeded, device functionality should not be assumed, damage may occur and reliability may be affected.

1. Derate linearly above +79°C free air temperature at a rate of 0.37mA/°C.
2. Maximum pulse width = 10 μs, maximum duty cycle = 11%.
3. Derate linearly above +79°C, free air temperature at the rate of 5.73 mW/°C.
4. No derating required across operating temperature range.

RECOMMENDED OPERATING CONDITIONS

Symbol	Parameter	Value	Unit
V _{DD} – V _{SS}	Power Supply	10 to 30	V
I _{F(ON)}	Input Current (ON)	10 to 16	mA
V _{F(OFF)}	Input Voltage (OFF)	-3.0 to 0.8	V

Functional operation above the stresses listed in the Recommended Operating Ranges is not implied. Extended exposure to stresses beyond the Recommended Operating Ranges limits may affect device reliability.

FOD3182

ELECTRICAL–OPTICAL CHARACTERISTICS (DC) (Apply over all recommended conditions, typical value is measured at $V_{DD} = 30\text{ V}$, $V_{SS} = 0\text{ V}$, $T_A = 25^\circ\text{C}$, unless otherwise specified.)

Symbol	Parameter	Test Conditions	Min	Typ	Max	Unit
I_{OH}	High Level Output Current	$V_{OH} = (V_{DD} - V_{SS} - 1\text{ V})$	0.5	0.9	–	A
		$V_{OH} = (V_{DD} - V_{SS} - 6\text{ V})$	2.5	–	–	
I_{OL}	Low Level Output Current	$V_{OL} = (V_{DD} - V_{SS} + 1\text{ V})$	0.5	1	–	A
		$V_{OL} = (V_{DD} - V_{SS} + 6\text{ V})$	2.5	–	–	
V_{OH}	High Level Output Voltage (Note 5, 6)	$I_O = -100\text{ mA}$	$V_{DD} - 0.5$	–	–	V
V_{OL}	Low Level Output Voltage (Note 5, 6)	$I_O = 100\text{ mA}$	–	–	$V_{SS} + 0.5$	V
I_{DDH}	High Level Supply Current	Output Open, $I_F = 10\text{ to }16\text{ mA}$	–	2.6	4.0	mA
I_{DDL}	Low Level Supply Current	Output Open, $V_F = -3.0\text{ to }0.8\text{ V}$	–	2.5	4.0	mA
I_{FLH}	Threshold Input Current Low to High	$I_O = 0\text{ mA}$, $V_O > 5\text{ V}$	–	3.0	7.5	mA
V_{FHL}	Threshold Input Voltage High to Low	$I_O = 0\text{ mA}$, $V_O < 5\text{ V}$	0.8	–	–	V
V_F	Input Forward Voltage	$I_F = 10\text{ mA}$	1.1	1.43	1.8	V
$\Delta V_F / T_A$	Temperature Coefficient of Forward Voltage	$I_F = 10\text{ mA}$	–	–1.5	–	mV/ $^\circ\text{C}$
V_{UVLO+}	UVLO Threshold	$V_O > 5\text{ V}$, $I_F = 10\text{ mA}$	7	8.3	9	V
V_{UVLO-}		$V_O < 5\text{ V}$, $I_F = 10\text{ mA}$	6.5	7.7	8.5	V
$UVLO_{HYST}$	UVLO Hysteresis		–	0.6	–	V
BV_R	Input Reverse Breakdown Voltage	$I_R = 10\ \mu\text{A}$	5	–	–	V
C_{IN}	Input Capacitance	$f = 1\text{ MHz}$, $V_F = 0\text{ V}$	–	25	–	pF

5. In this test, V_{OH} is measured with a dc load current of 100 mA. When driving capacitive load V_{OH} will approach V_{DD} as I_{OH} approaches zero amps.
6. Maximum pulse width = 1 ms, maximum duty cycle = 20%.

FOD3182

SWITCHING CHARACTERISTICS (Apply over all recommended conditions, typical value is measured at $V_{DD} = 30\text{ V}$, $V_{SS} = 0\text{ V}$, $T_A = 25^\circ\text{C}$, unless otherwise specified.)

Symbol	Parameter	Test Conditions	Min	Typ	Max	Unit
t_{PLH}	Propagation Delay Time to High Output Level (Note 7)	$I_F = 10\text{ mA}$, $R_g = 10\ \Omega$, $f = 250\text{ kHz}$, Duty Cycle = 50%, $C_g = 10\text{ nF}$	50	120	210	ns
t_{PHL}	Propagation Delay Time to Low Output Level (Note 7)		50	145	210	ns
P_{WD}	Pulse Width Distortion (Note 8)		–	35	65	ns
P_{DD} ($t_{PHL} - t_{PLH}$)	Propagation Delay Difference Between Any Two Parts (Note 9)		–90	–	90	ns
t_r	Rise Time	$C_L = 10\text{ nF}$, $R_g = 10\ \Omega$	–	38	–	ns
t_f	Fall Time		–	24	–	ns
$t_{UVLO\ ON}$	UVLO Turn On Delay		–	2.0	–	μs
$t_{UVLO\ OFF}$	UVLO Turn Off Delay		–	0.3	–	μs
$ CM_H $	Output High Level Common Mode Transient Immunity (Note 10, 11)	$T_A = +25^\circ\text{C}$, $I_f = 7\text{ mA}$ to 16 mA , $V_{CM} = 2\text{ kV}$, $V_{DD} = 30\text{ V}$	35	50	–	$\text{kV}/\mu\text{s}$
$ CM_L $	Output Low Level Common Mode Transient Immunity (Note 10, 12)	$T_A = +25^\circ\text{C}$, $V_f = 0\text{ V}$, $V_{CM} = 2\text{ kV}$, $V_{DD} = 30\text{ V}$	35	50	–	$\text{kV}/\mu\text{s}$

7. t_{PHL} propagation delay is measured from the 50% level on the falling edge of the input pulse to the 50% level of the falling edge of the V_O signal. t_{PLH} propagation delay is measured from the 50% level on the rising edge of the input pulse to the 50% level of the rising edge of the V_O signal.
8. PWD is defined as $|t_{PHL} - t_{PLH}|$ for any given device.
9. The difference between t_{PHL} and t_{PLH} between any two FOD3182 parts under same operating conditions, with equal loads.
10. Pin 1 and 4 need to be connected to LED common.
11. Common mode transient immunity in the high state is the maximum tolerable dV_{CM}/dt of the common mode pulse V_{CM} to assure that the output will remain in the high state (i.e. $V_O > 15\text{ V}$).
12. Common mode transient immunity in a low state is the maximum tolerable dV_{CM}/dt of the common mode pulse, V_{CM} , to assure that the output will remain in a low state (i.e. $V_O < 1.0\text{ V}$).

INSULATION CHARACTERISTICS

Symbol	Parameter	Test Conditions	Min	Typ*	Max	Unit
V_{ISO}	Withstand Isolation Voltage (Note 13, 14)	$T_A = 25^\circ\text{C}$, R.H. < 50%, $t = 1\text{ minute}$, $I_{I-O} \leq 10\ \mu\text{A}$	5000	–	–	V_{rms}
R_{I-O}	Resistance (Input to Output) (Note 14)	$V_{I-O} = 500\text{ V}$	–	10^{11}	–	Ω
C_{I-O}	Capacitance (Input to Output)	Freq. = 1 MHz	–	1	–	pF

*Typical values at $T_A = 25^\circ\text{C}$

13. In accordance with UL 1577, each optocoupler is proof tested by applying an insulation test voltage $> 6000\text{ V}_{rms}$, 60 Hz for 1 second (leakage detection current limit $I_{I-O} < 10\ \mu\text{A}$).
14. Device considered a two-terminal device: pins on input side shorted together and pins on output side shorted together.

TYPICAL PERFORMANCE CURVES

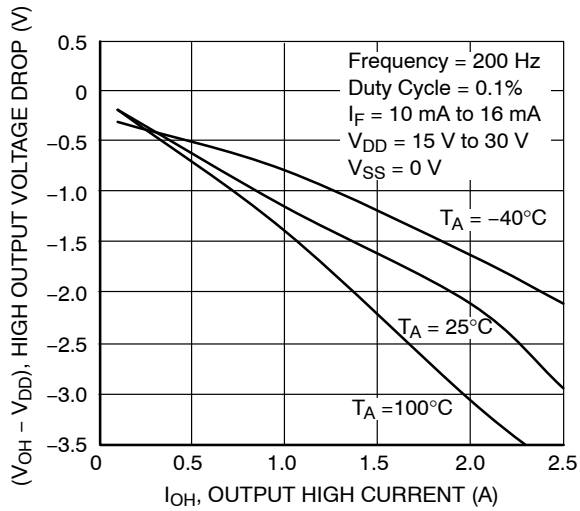

Figure 1. Output High Voltage Drop vs. Output High Current

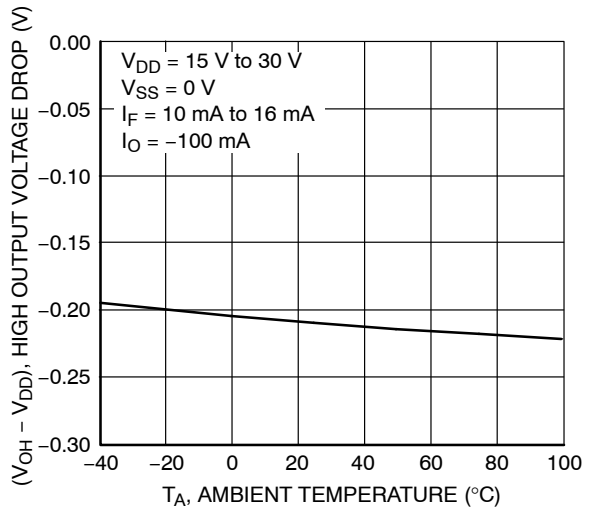

Figure 2. Output High Voltage Drop vs. Ambient Temperature

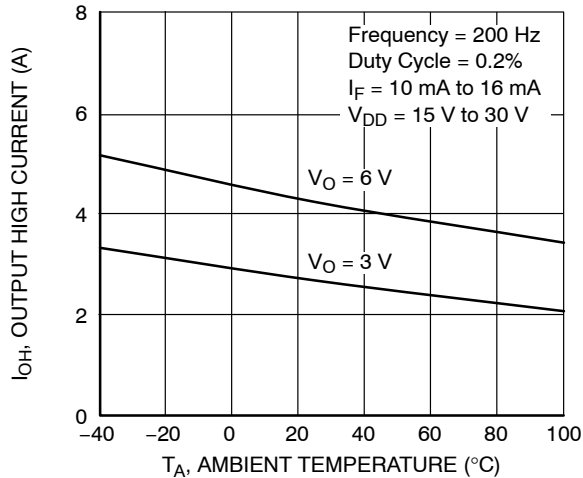

Figure 3. Output High Current vs. Ambient Temperature

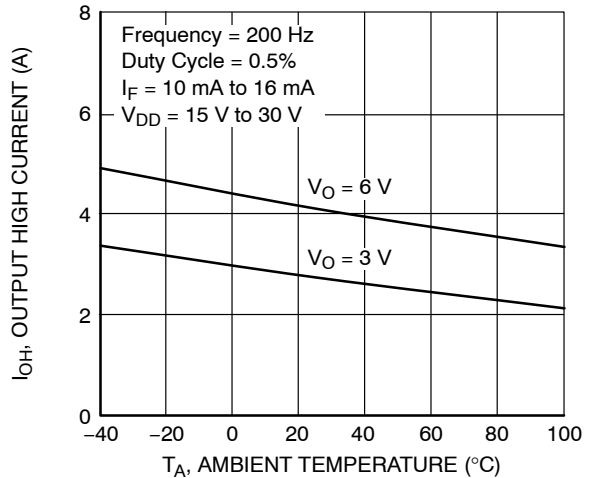

Figure 4. Output High Current vs. Ambient Temperature

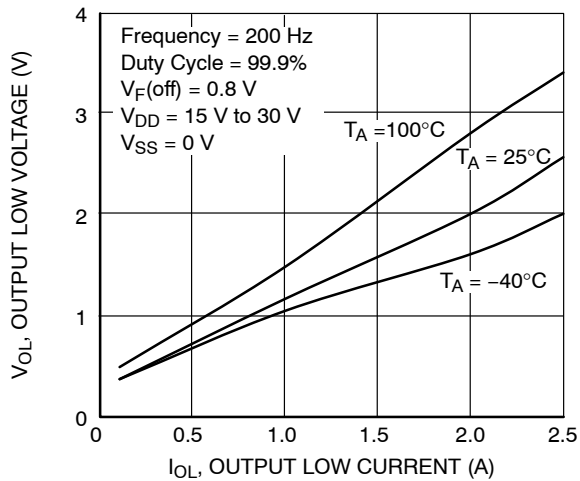

Figure 5. Output Low Voltage vs. Output Low Current

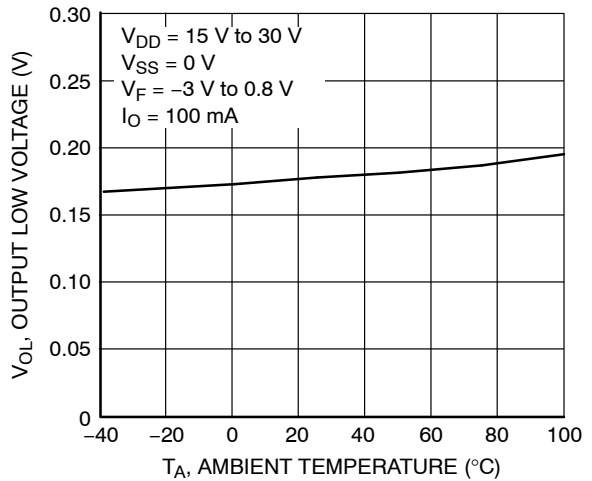

Figure 6. Output Low Voltage vs. Ambient Temperature

TYPICAL PERFORMANCE CURVES (Continued)

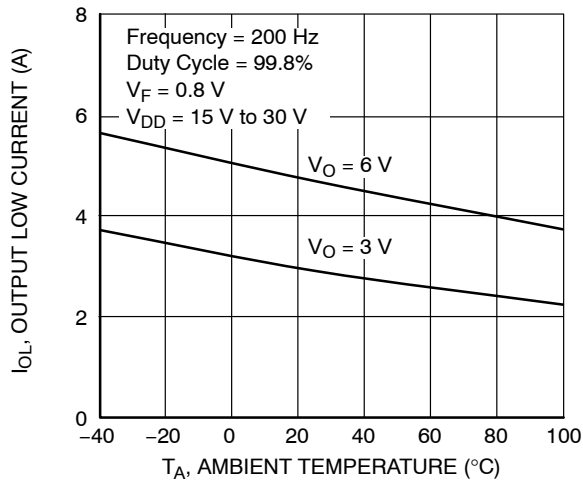

Figure 7. Output Low Current vs. Ambient Temperature

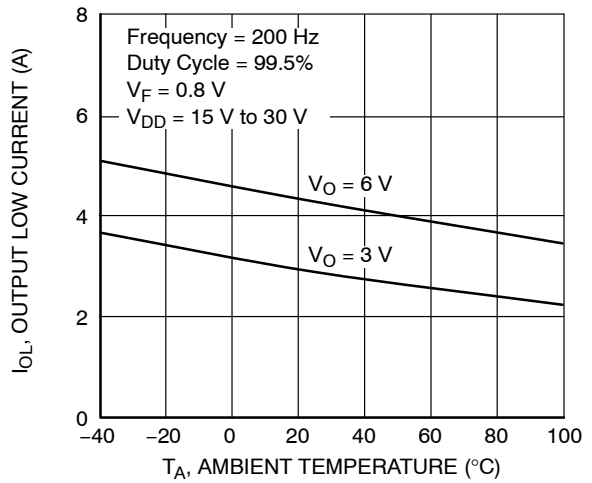

Figure 8. Output Low Current vs. Ambient Temperature

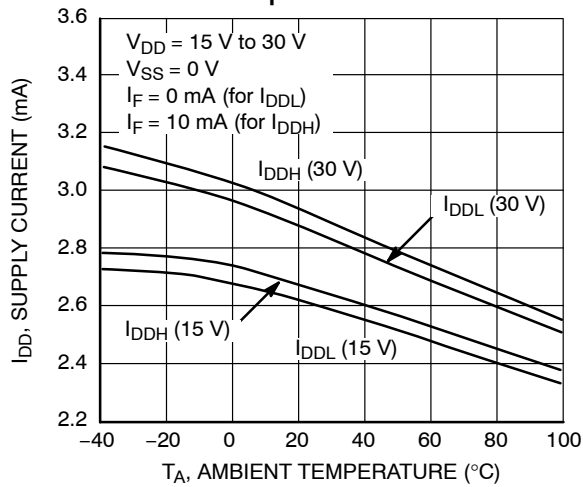

Figure 9. Supply Current vs. Ambient Temperature

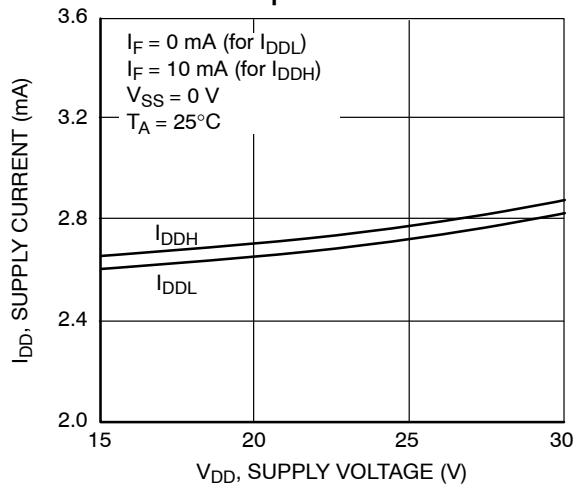

Figure 10. Supply Current vs. Supply Voltage

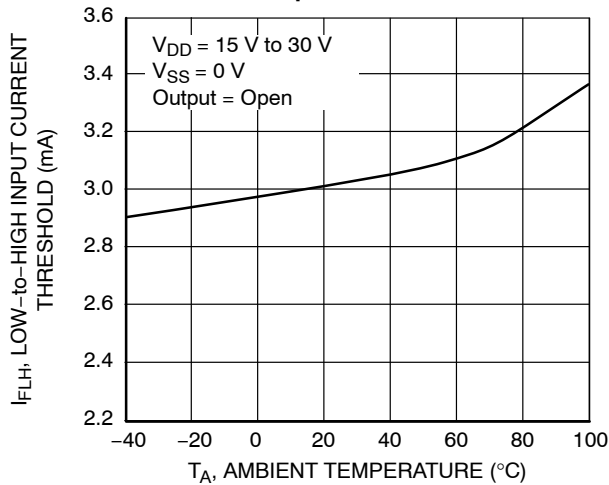

Figure 11. Low-to-High Input Current Threshold vs. Ambient Temperature

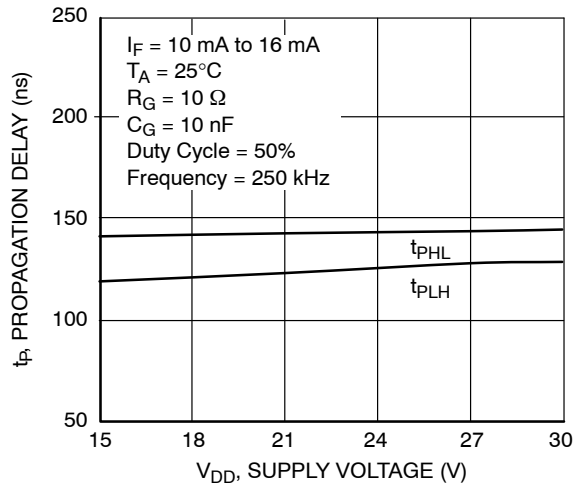

Figure 12. Propagation Delay vs. Supply Voltage

TYPICAL PERFORMANCE CURVES (Continued)

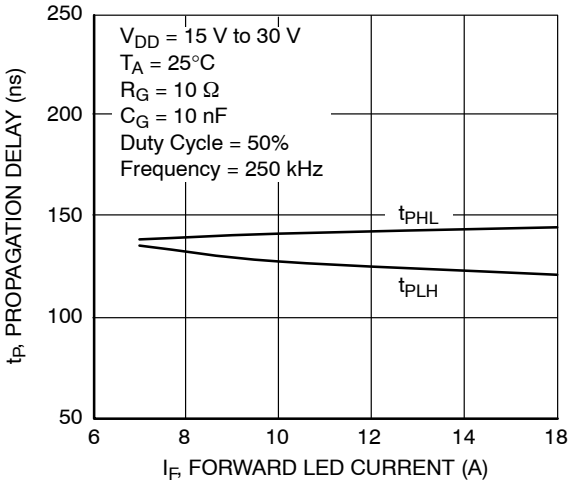

Figure 13. Propagation Delay vs. LED Forward Current

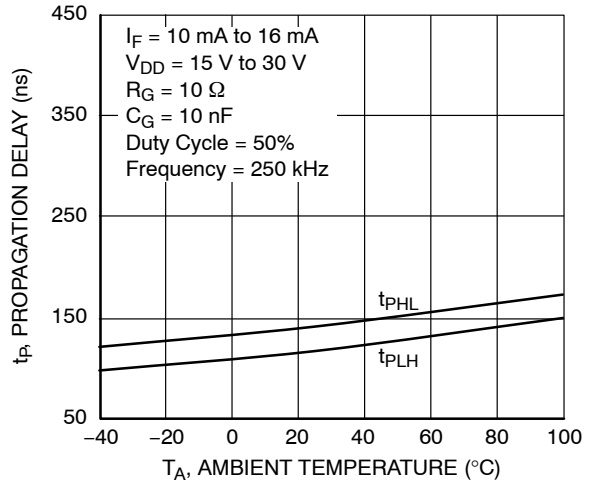

Figure 14. Propagation Delay vs. Ambient Temperature

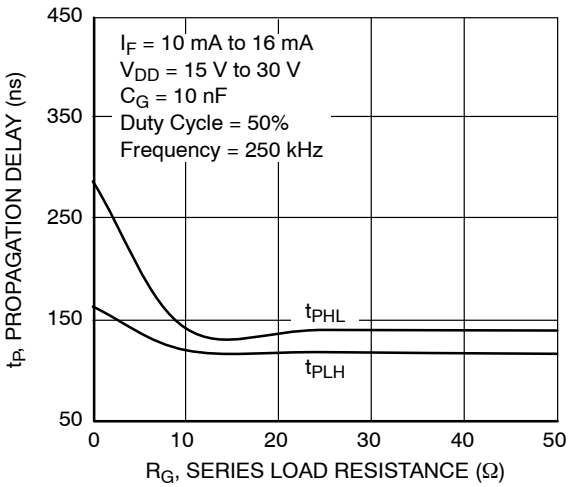

Figure 15. Propagation Delay vs. Series Load Resistance

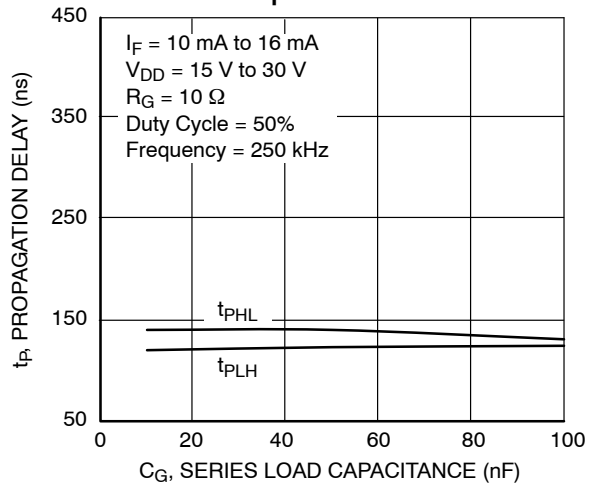

Figure 16. Propagation Delay vs. Series Load Capacitance

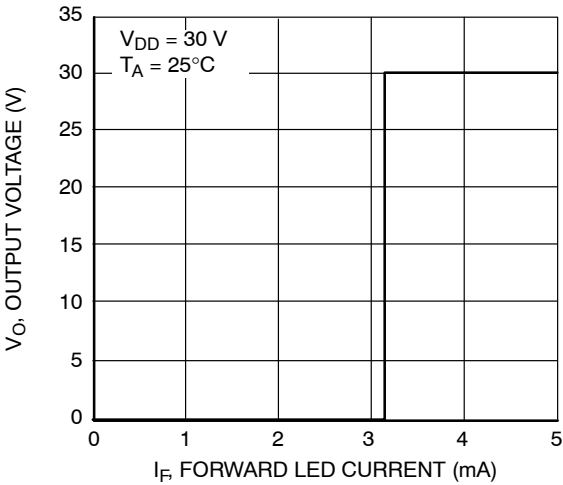

Figure 17. Transfer Characteristics

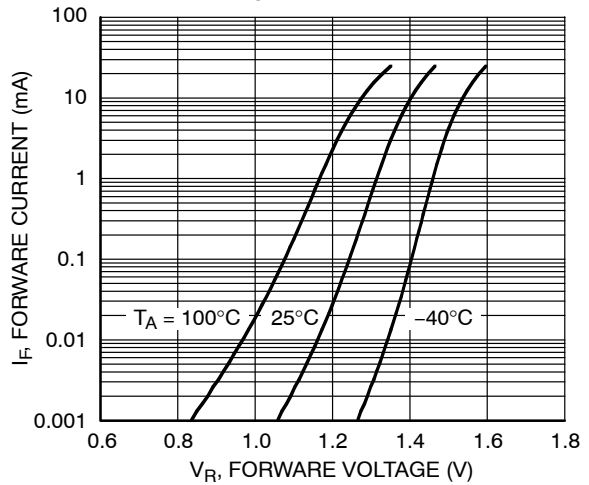

Figure 18. Input Forward Current vs. Forward Voltage

TYPICAL PERFORMANCE CURVES (Continued)

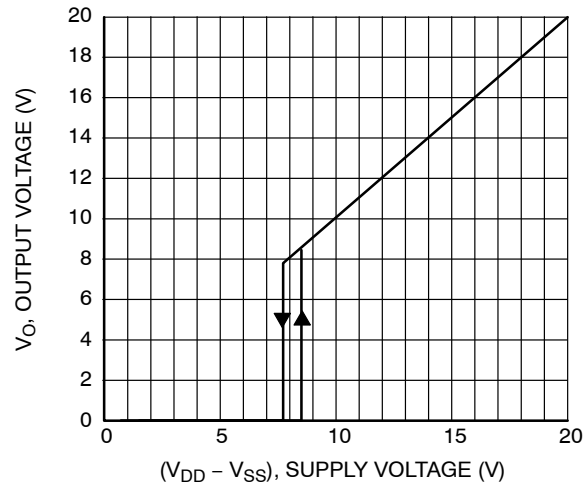

Figure 19. Under Voltage Lockout

FOD3182

TEST CIRCUIT

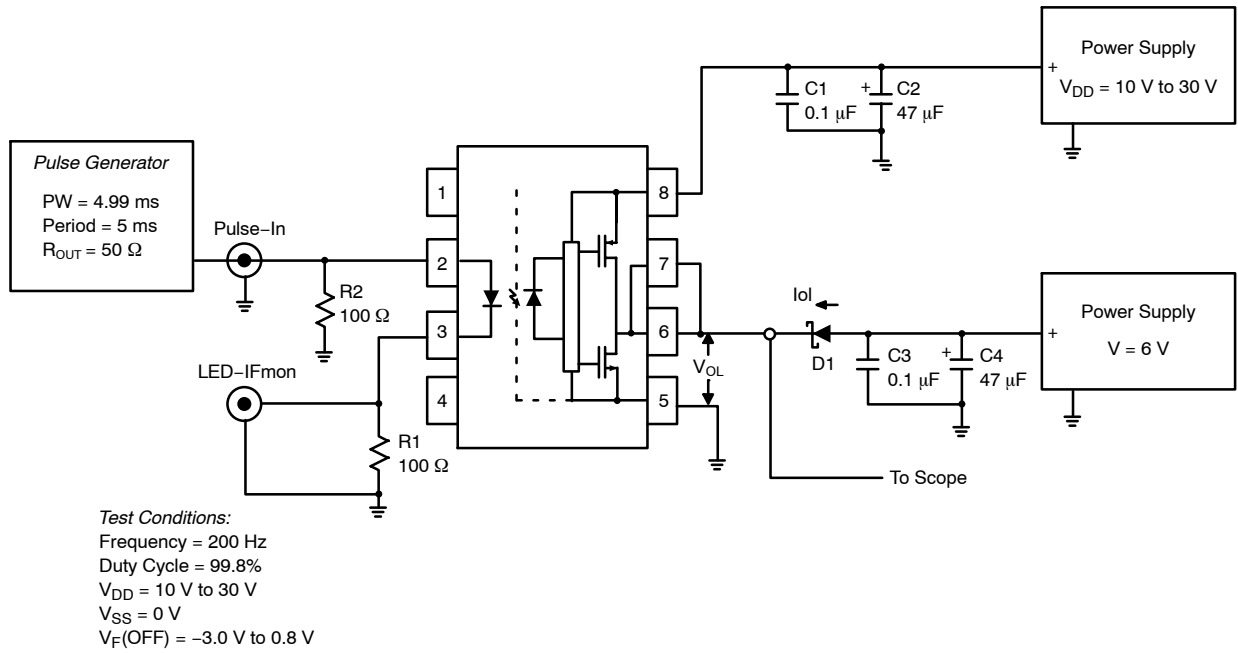

Figure 20. I_{OL} Test Circuit

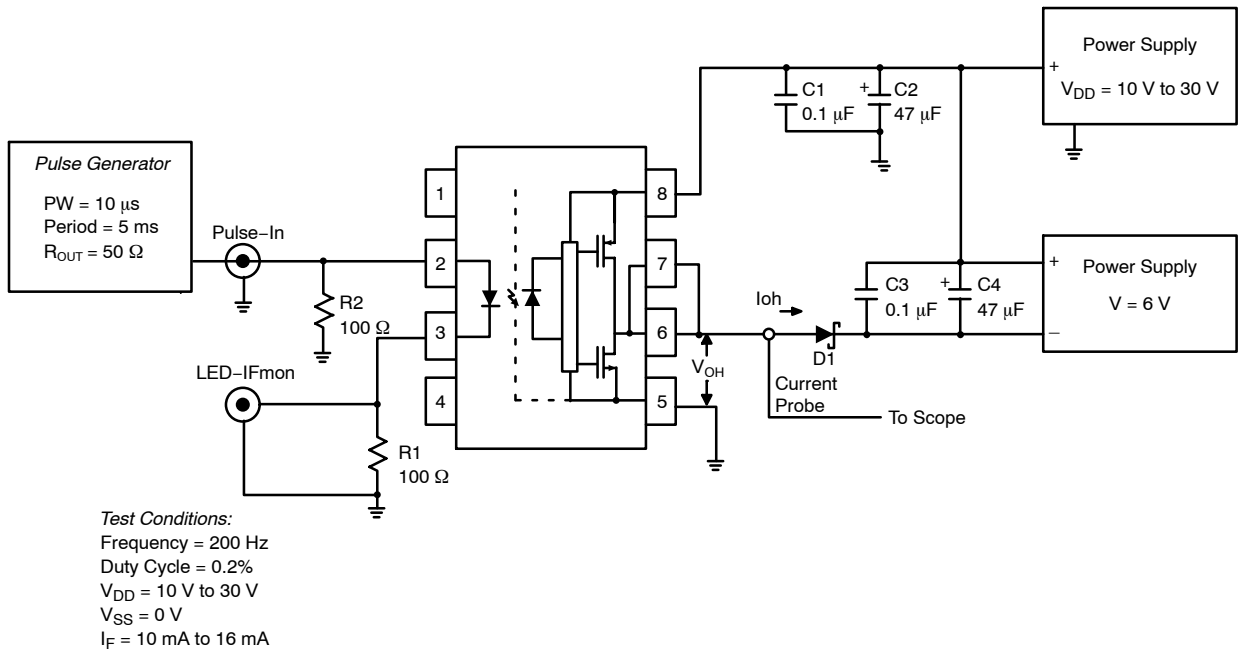

Figure 21. I_{OH} Test Circuit

FOD3182

TEST CIRCUIT (Continued)

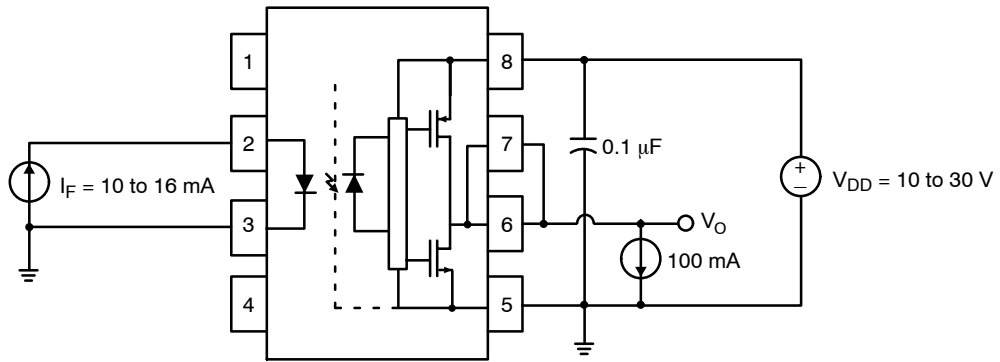

Figure 22. V_{OH} Test Circuit

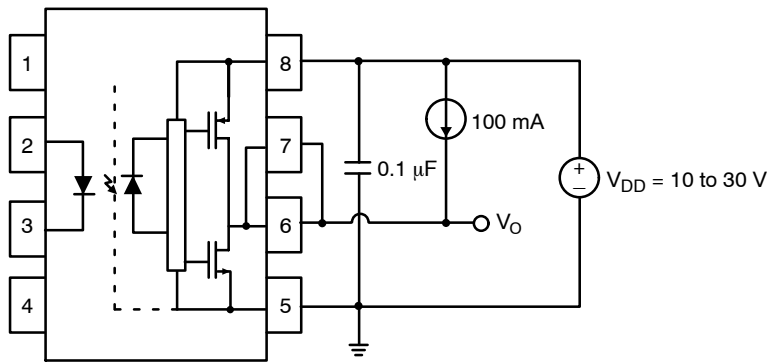

Figure 23. V_{OL} Test Circuit

FOD3182

TEST CIRCUIT (Continued)

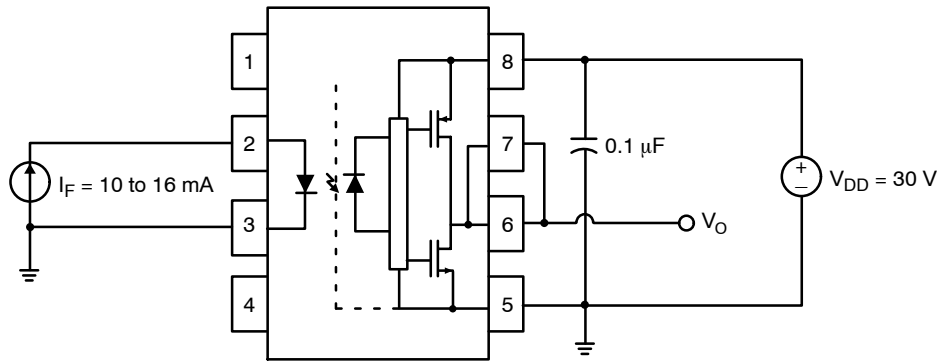

Figure 24. I_{DDH} Test Circuit

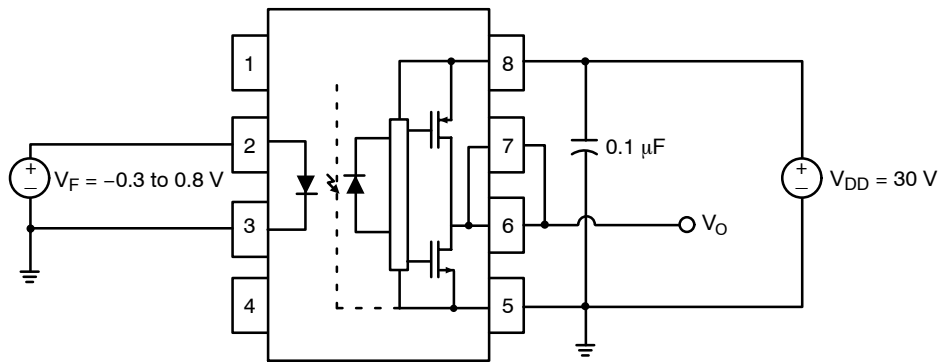

Figure 25. I_{DDL} Test Circuit

FOD3182

TEST CIRCUIT (Continued)

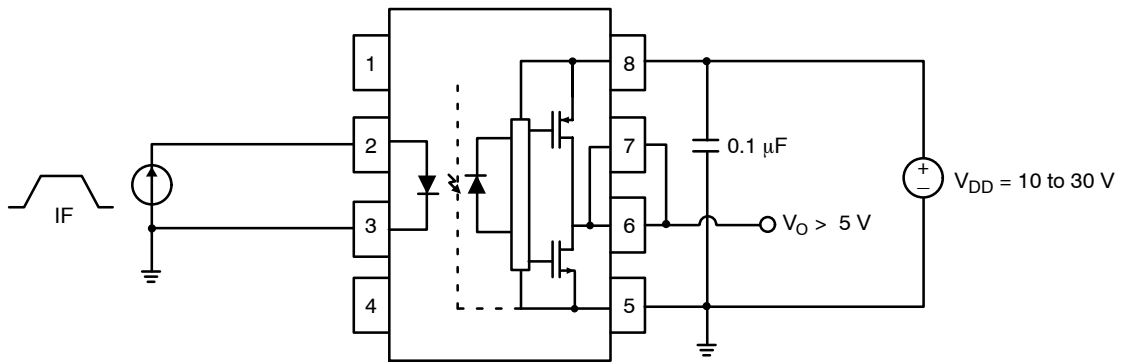

Figure 26. I_{FLH} Test Circuit

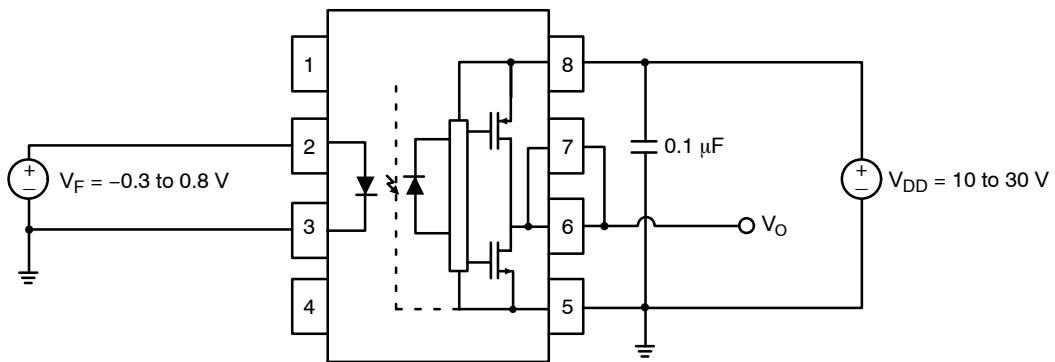

Figure 27. I_{FHL} Test Circuit

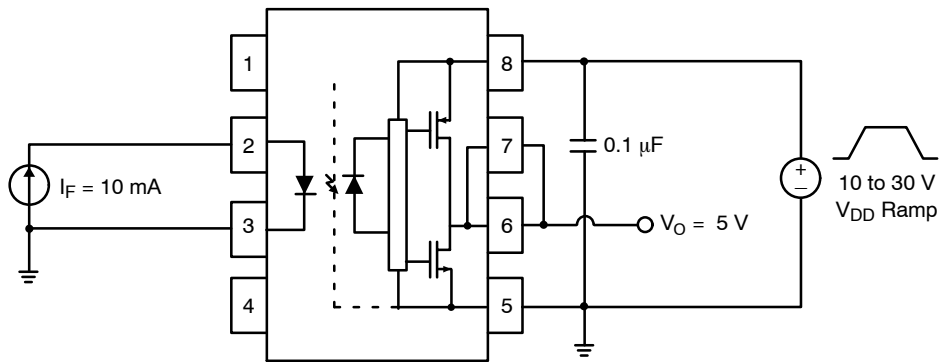

Figure 28. UVLO Test Circuit

FOD3182

TEST CIRCUIT (Continued)

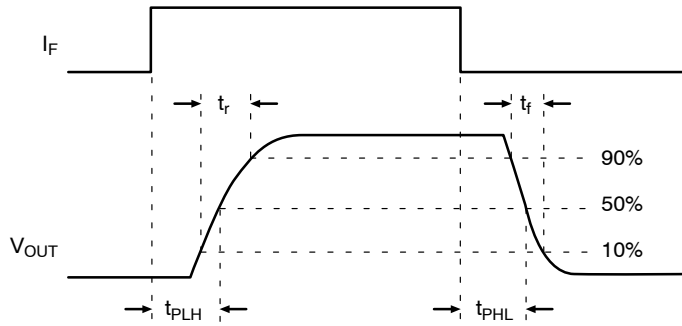
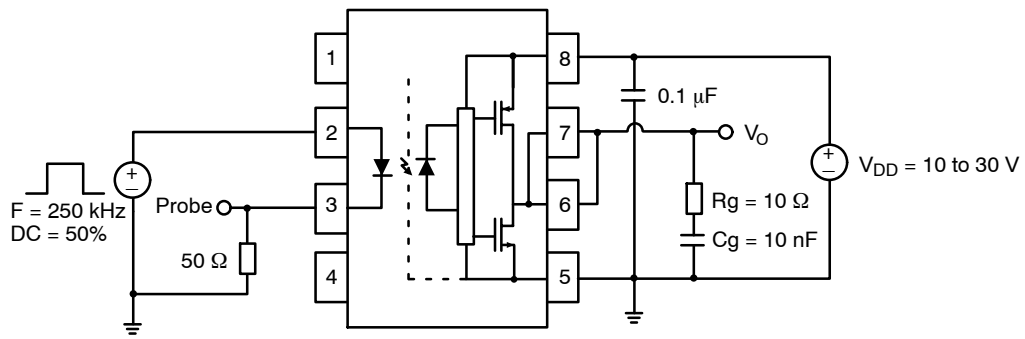

Figure 29. t_{PHL} , t_{PLH} , t_r and t_f Test Circuit and Waveforms

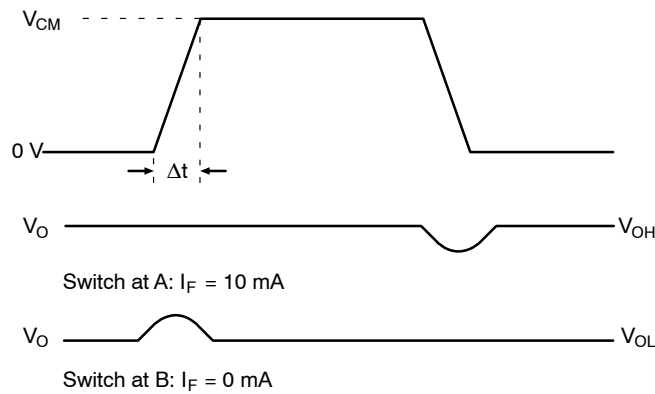
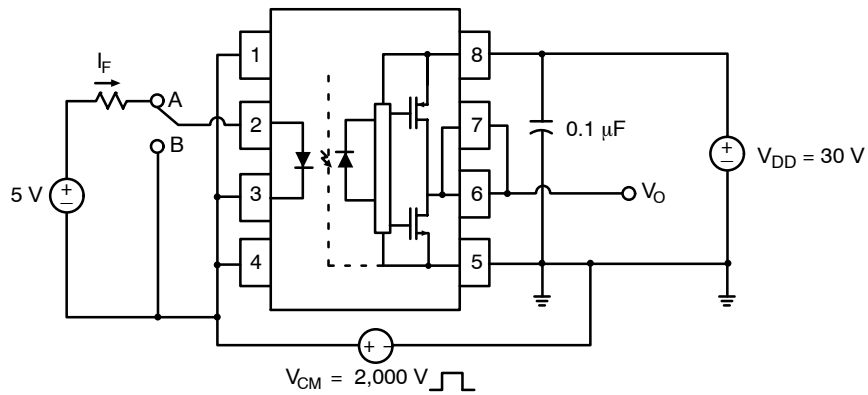

Figure 30. CMR Test Circuit and Waveforms

REFLOW PROFILE

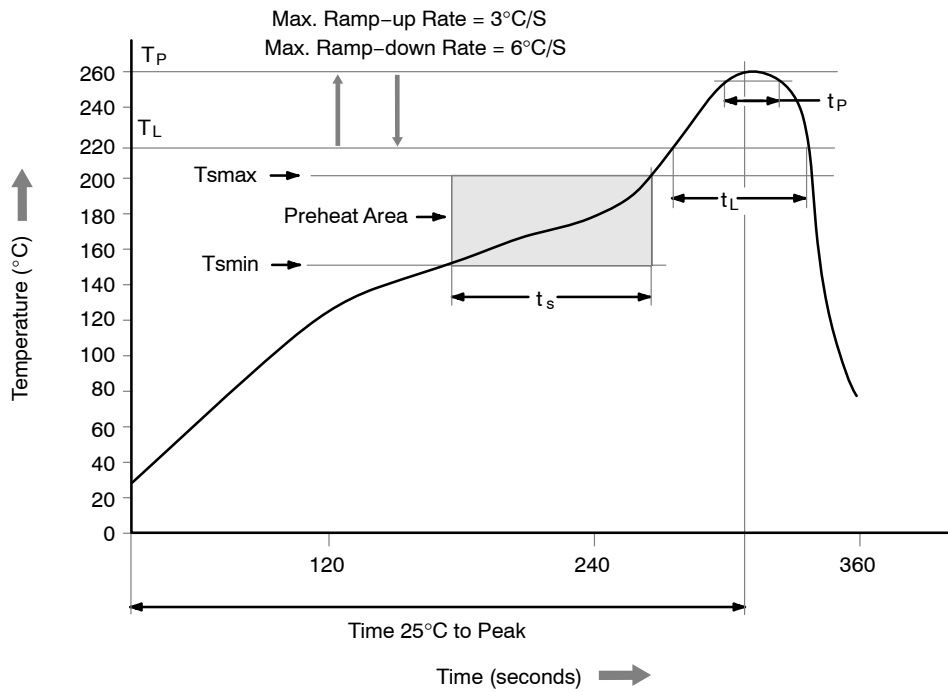

Figure 31. Reflow Profile

Table 1.

Profile Feature	Pb-Free Assembly Profile
Temperature Min. (Tsmmin)	150°C
Temperature Max. (Tsmmax)	200°C
Time (ts) from (Tsmmin to Tsmmax)	60–120 seconds
Ramp-up Rate (tL to tp)	3°C/second max.
Liquidous Temperature (TL)	217°C
Time (tL) Maintained Above (TL)	60–150 seconds
Peak Body Package Temperature	260°C +0°C / -5°C
Time (tp) within 5°C of 260°C	30 seconds
Ramp-down Rate (TP to TL)	6°C/second max.
Time 25°C to Peak Temperature	8 minutes max.

FOD3182

ORDERING INFORMATION

Part Number	Package	Shipping [†]
FOD3182	PDIP8 9.655x6.61, 2.54P DIP 8-Pin	50 Units / Tube
FOD3182S	PDIP8 GW SMT 8-Pin (Lead Bend)	50 Units / Tube
FOD3182SD	PDIP8 GW SMT 8-Pin (Lead Bend)	1,000 / Tape and Reel
FOD3182V	PDIP8 9.655x6.61, 2.54P DIP 8-Pin, IEC60747-5-2 option	50 Units / Tube
FOD3182SV	PDIP8 GW SMT 8-Pin (Lead Bend), DIN EN/IEC 60747-5-2 option	50 Units / Tube
FOD3182SDV	PDIP8 GW SMT 8-Pin (Lead Bend), DIN EN/IEC 60747-5-2 option	1,000 / Tape and Reel
FOD3182TV	PDIP8 6.6x3.81, 2.54P DIP 8-Pin, 0.4" Lead Spacing, DIN EN/IEC 60747-5-2 option	50 Units / Tube
FOD3182TSV	PDIP8 GW SMT 8-Pin, 0.4" Lead Spacing, DIN EN/IEC 60747-5-2 option	50 Units / Tube
FOD3182TSR2	PDIP8 GW SMT 8-Pin, 0.4" Lead Spacing	700 / Tape and Reel
FOD3182TSR2V	PDIP8 GW SMT 8-Pin, 0.4" Lead Spacing, DIN EN/IEC 60747-5-2 option	700 / Tape and Reel

[†]For information on tape and reel specifications, including part orientation and tape sizes, please refer to our Tape and Reel Packaging Specifications Brochure, BRD8011/D.

MECHANICAL CASE OUTLINE
PACKAGE DIMENSIONS

PDIP8 6.6x3.81, 2.54P
CASE 646BW
ISSUE O

DATE 31 JUL 2016

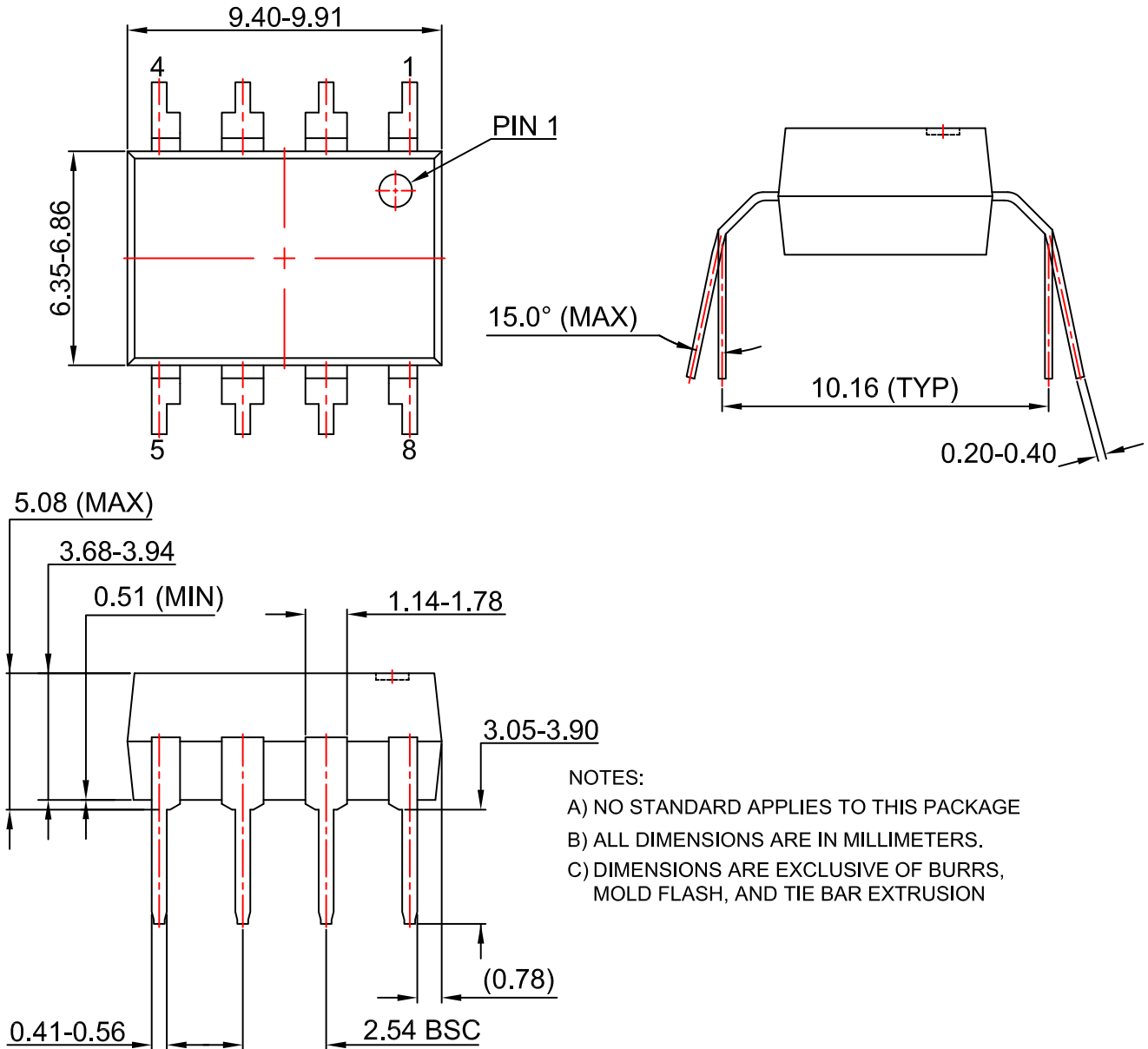

- NOTES:
A) NO STANDARD APPLIES TO THIS PACKAGE
B) ALL DIMENSIONS ARE IN MILLIMETERS.
C) DIMENSIONS ARE EXCLUSIVE OF BURRS, MOLD FLASH, AND TIE BAR EXTRUSION

DOCUMENT NUMBER:	98AON13445G	Electronic versions are uncontrolled except when accessed directly from the Document Repository. Printed versions are uncontrolled except when stamped "CONTROLLED COPY" in red.
DESCRIPTION:	PDIP8 6.6X3.81, 2.54P	PAGE 1 OF 1

ON Semiconductor and **ON** are trademarks of Semiconductor Components Industries, LLC dba ON Semiconductor or its subsidiaries in the United States and/or other countries. ON Semiconductor reserves the right to make changes without further notice to any products herein. ON Semiconductor makes no warranty, representation or guarantee regarding the suitability of its products for any particular purpose, nor does ON Semiconductor assume any liability arising out of the application or use of any product or circuit, and specifically disclaims any and all liability, including without limitation special, consequential or incidental damages. ON Semiconductor does not convey any license under its patent rights nor the rights of others.

MECHANICAL CASE OUTLINE

PACKAGE DIMENSIONS

ON Semiconductor®



PDIP8 9.655x6.6, 2.54P
CASE 646CQ
ISSUE O

DATE 18 SEP 2017

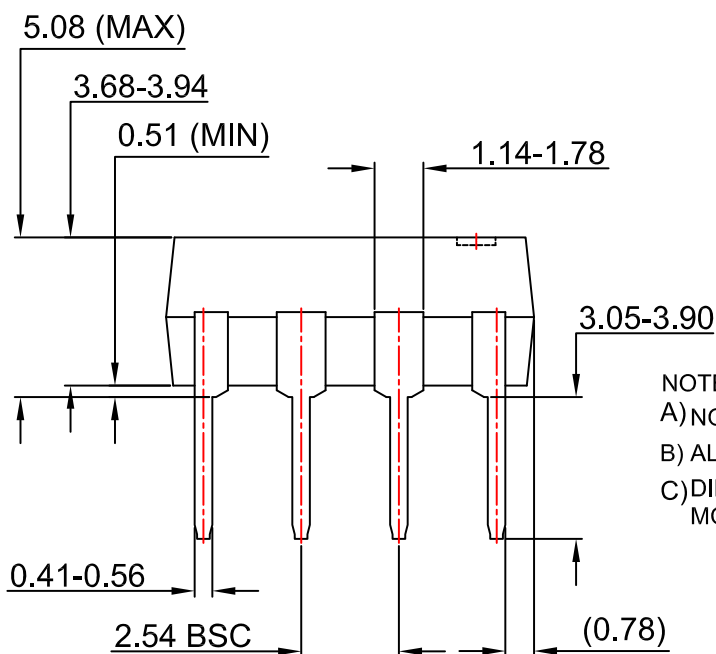
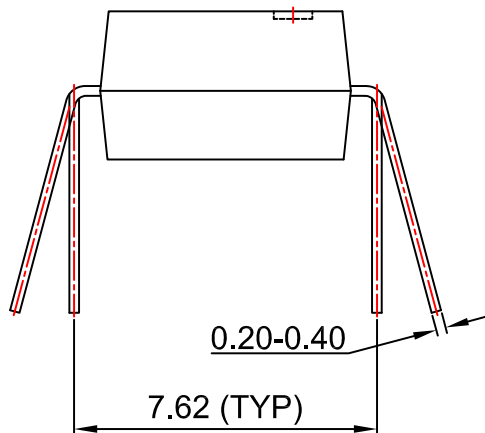
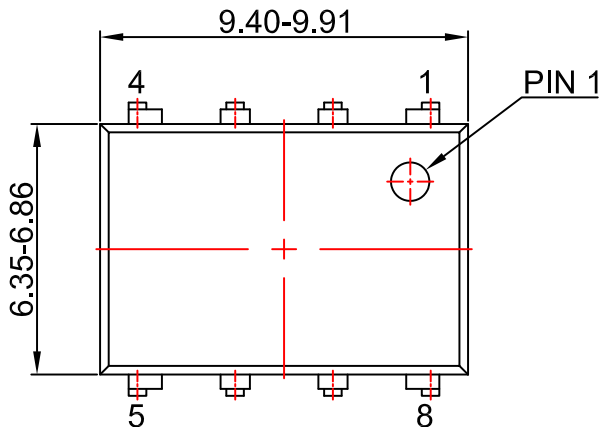

NOTES:
A) NO STANDARD APPLIES TO THIS PACKAGE
B) ALL DIMENSIONS ARE IN MILLIMETERS.
C) DIMENSIONS ARE EXCLUSIVE OF BURRS, MOLD FLASH, AND TIE BAR EXTRUSION

DOCUMENT NUMBER:	98AON13446G	Electronic versions are uncontrolled except when accessed directly from the Document Repository. Printed versions are uncontrolled except when stamped "CONTROLLED COPY" in red.
DESCRIPTION:	PDIP8 9.655X6.6, 2.54P	PAGE 1 OF 1

ON Semiconductor and are trademarks of Semiconductor Components Industries, LLC dba ON Semiconductor or its subsidiaries in the United States and/or other countries. ON Semiconductor reserves the right to make changes without further notice to any products herein. ON Semiconductor makes no warranty, representation or guarantee regarding the suitability of its products for any particular purpose, nor does ON Semiconductor assume any liability arising out of the application or use of any product or circuit, and specifically disclaims any and all liability, including without limitation special, consequential or incidental damages. ON Semiconductor does not convey any license under its patent rights nor the rights of others.

MECHANICAL CASE OUTLINE

PACKAGE DIMENSIONS

ON Semiconductor®



PDIP8 GW
CASE 709AC
ISSUE O

DATE 31 JUL 2016

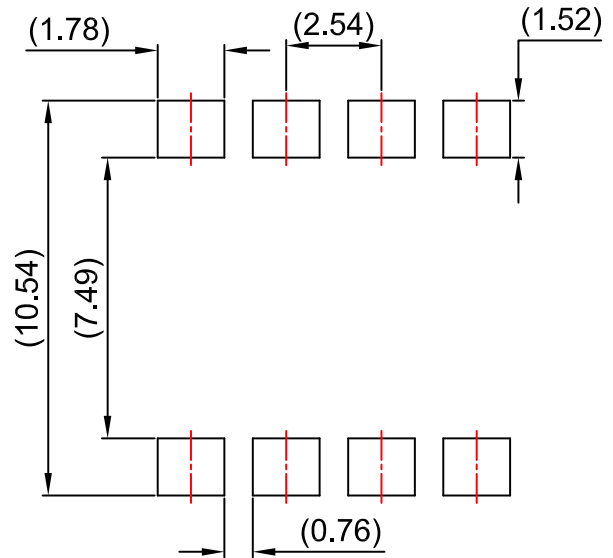
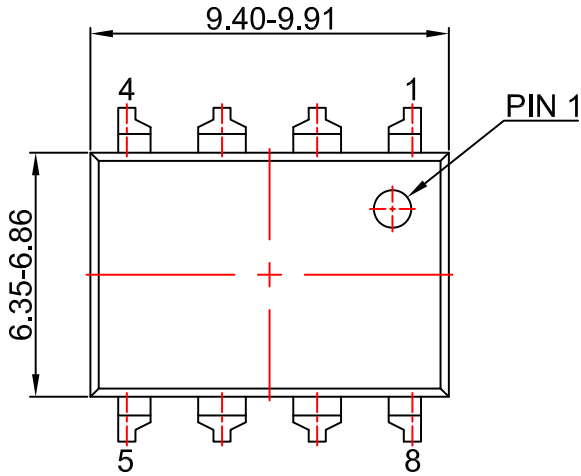

LAND PATTERN RECOMMENDATION

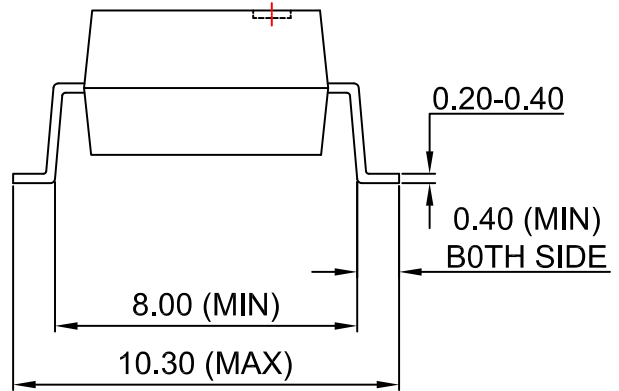
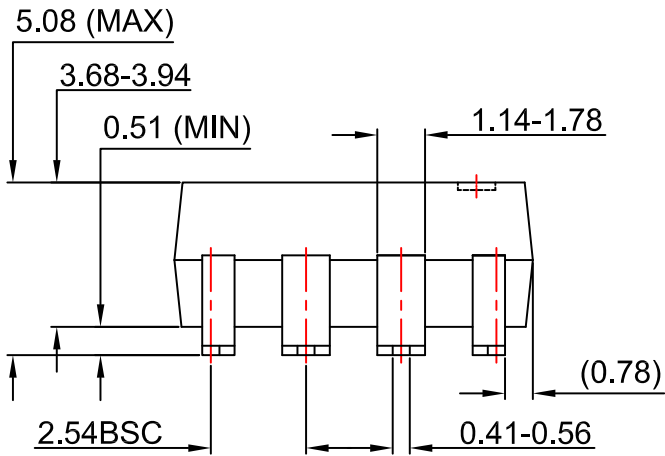

NOTES:

- A) NO STANDARD APPLIES TO THIS PACKAGE
- B) ALL DIMENSIONS ARE IN MILLIMETERS.
- C) DIMENSIONS ARE EXCLUSIVE OF BURRS, MOLD FLASH, AND TIE BAR EXTRUSION

DOCUMENT NUMBER:	98AON13447G	Electronic versions are uncontrolled except when accessed directly from the Document Repository. Printed versions are uncontrolled except when stamped "CONTROLLED COPY" in red.
DESCRIPTION:	PDIP8 GW	PAGE 1 OF 1

ON Semiconductor and are trademarks of Semiconductor Components Industries, LLC dba ON Semiconductor or its subsidiaries in the United States and/or other countries. ON Semiconductor reserves the right to make changes without further notice to any products herein. ON Semiconductor makes no warranty, representation or guarantee regarding the suitability of its products for any particular purpose, nor does ON Semiconductor assume any liability arising out of the application or use of any product or circuit, and specifically disclaims any and all liability, including without limitation special, consequential or incidental damages. ON Semiconductor does not convey any license under its patent rights nor the rights of others.

MECHANICAL CASE OUTLINE

PACKAGE DIMENSIONS

ON Semiconductor®



PDIP8 GW
CASE 709AD
ISSUE O

DATE 31 JUL 2016

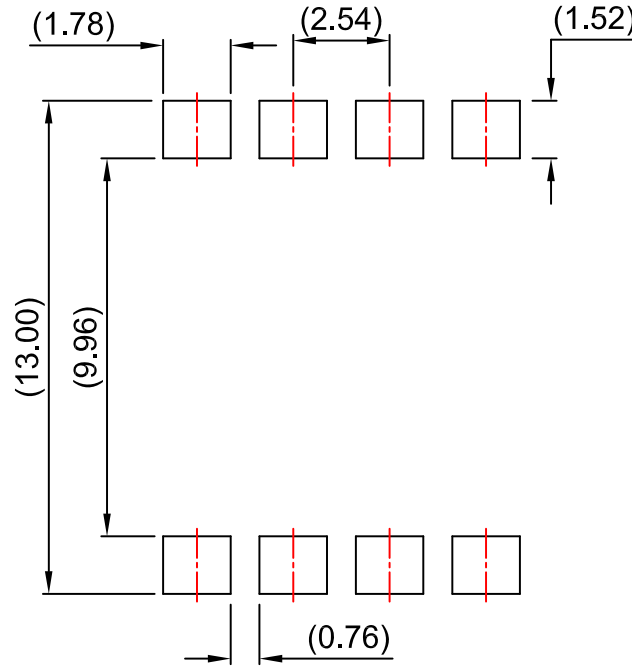
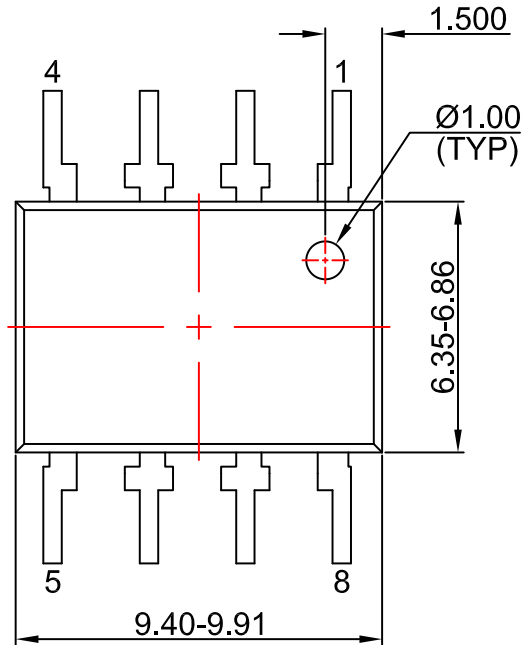

LAND PATTERN RECOMMENDATION

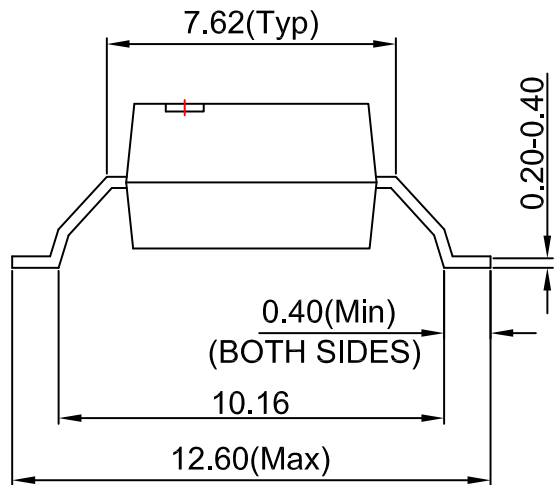
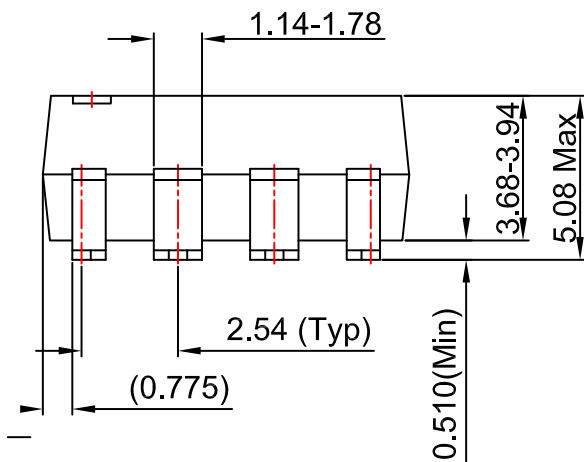

NOTES:

- A) NO STANDARD APPLIES TO THIS PACKAGE
- B) ALL DIMENSIONS ARE IN MILLIMETERS.
- C) DIMENSIONS ARE EXCLUSIVE OF BURRS, MOLD FLASH, AND TIE BAR EXTRUSION

DOCUMENT NUMBER:	98AON13448G	Electronic versions are uncontrolled except when accessed directly from the Document Repository. Printed versions are uncontrolled except when stamped "CONTROLLED COPY" in red.
DESCRIPTION:	PDIP8 GW	PAGE 1 OF 1

ON Semiconductor and are trademarks of Semiconductor Components Industries, LLC dba ON Semiconductor or its subsidiaries in the United States and/or other countries. ON Semiconductor reserves the right to make changes without further notice to any products herein. ON Semiconductor makes no warranty, representation or guarantee regarding the suitability of its products for any particular purpose, nor does ON Semiconductor assume any liability arising out of the application or use of any product or circuit, and specifically disclaims any and all liability, including without limitation special, consequential or incidental damages. ON Semiconductor does not convey any license under its patent rights nor the rights of others.

onsemi, **Onsemi**, and other names, marks, and brands are registered and/or common law trademarks of Semiconductor Components Industries, LLC dba "**onsemi**" or its affiliates and/or subsidiaries in the United States and/or other countries. **onsemi** owns the rights to a number of patents, trademarks, copyrights, trade secrets, and other intellectual property. A listing of **onsemi**'s product/patent coverage may be accessed at www.onsemi.com/site/pdf/Patent-Marking.pdf. **onsemi** reserves the right to make changes at any time to any products or information herein, without notice. The information herein is provided "as-is" and **onsemi** makes no warranty, representation or guarantee regarding the accuracy of the information, product features, availability, functionality, or suitability of its products for any particular purpose, nor does **onsemi** assume any liability arising out of the application or use of any product or circuit, and specifically disclaims any and all liability, including without limitation special, consequential or incidental damages. Buyer is responsible for its products and applications using **onsemi** products, including compliance with all laws, regulations and safety requirements or standards, regardless of any support or applications information provided by **onsemi**. "Typical" parameters which may be provided in **onsemi** data sheets and/or specifications can and do vary in different applications and actual performance may vary over time. All operating parameters, including "Typicals" must be validated for each customer application by customer's technical experts. **onsemi** does not convey any license under any of its intellectual property rights nor the rights of others. **onsemi** products are not designed, intended, or authorized for use as a critical component in life support systems or any FDA Class 3 medical devices or medical devices with a same or similar classification in a foreign jurisdiction or any devices intended for implantation in the human body. Should Buyer purchase or use **onsemi** products for any such unintended or unauthorized application, Buyer shall indemnify and hold **onsemi** and its officers, employees, subsidiaries, affiliates, and distributors harmless against all claims, costs, damages, and expenses, and reasonable attorney fees arising out of, directly or indirectly, any claim of personal injury or death associated with such unintended or unauthorized use, even if such claim alleges that **onsemi** was negligent regarding the design or manufacture of the part. **onsemi** is an Equal Opportunity/Affirmative Action Employer. This literature is subject to all applicable copyright laws and is not for resale in any manner.

ADDITIONAL INFORMATION

TECHNICAL PUBLICATIONS:



Technical Library: www.onsemi.com/design/resources/technical-documentation
onsemi Website: www.onsemi.com

ONLINE SUPPORT: www.onsemi.com/support

For additional information, please contact your local Sales Representative at www.onsemi.com/support/sales

Looking for pricing, stock, or lifecycle information?

Click below to explore more details on WIN SOURCE:

-  [View FOD3182V on WIN SOURCE](#)
-  [ON Semiconductor](#) Information

Optimize Your Supply Chain with WIN SOURCE Solutions

-  Global Sourcing Solution
-  Obsolete Management
-  Cost Control Management
-  Shortage Management
-  Alternative Solution
-  Excess Inventory Management