



**THE DATASHEET OF
FN9222R-20-06**



DS91M125 125 MHz 1:4 M-LVDS Repeater with LVDS Input

Check for Samples: [DS91M125](#)

FEATURES

- **DC - 125 MHz / 250 Mbps Low Jitter, Low Skew, Low Power Operation**
- **Independent Driver Enable Pins**
- **Outputs Conform to TIA/EIA-899 M-LVDS Standard**
- **Controlled Transition Times Minimize Reflections**
- **Inputs Conform to TIA/EIA-644-A LVDS Standard**
- **8 kV ESD on M-LVDS Output Pins Protects Adjoining Components**
- **Flow-Through Pinout Simplifies PCB Layout**
- **Industrial Operating Temperature Range (-40°C to +85°C)**
- **Available in a Space Saving SOIC-16 Package**

APPLICATIONS

- **Multidrop / Multipoint Clock and Data Distribution**
- **High-Speed, Low Power, Short-Reach Alternative to TIA/EIA-485/422**
- **Clock Distribution in AdvancedTCA (ATCA) and MicroTCA (μ TCA, uTCA) Backplanes**

DESCRIPTION

The DS91M125 is a 1:4 M-LVDS repeater designed for driving and distributing clock or data signals to up to four multipoint networks.

M-LVDS (Multipoint LVDS) is a new family of bus interface devices based on LVDS technology specifically designed for multipoint and multidrop cable and backplane applications. It differs from standard LVDS in providing increased drive current to handle double terminations that are required in multipoint applications. Controlled transition times minimize reflections that are common in multipoint configurations due to unterminated stubs.

A single DS91M125 channel is a 1:4 repeater that accepts M-LVDS/LVDS/CML/LVPECL signals and converts them to M-LVDS signal levels. Each output has an associated independent driver enable pin. The DS91M125 input conforms to the LVDS standard.

The DS91M125 has a flow-through pinout for easy PCB layout. It provides a new alternative for high speed multipoint interface applications. It is packaged in a space saving SOIC-16 package.



Please be aware that an important notice concerning availability, standard warranty, and use in critical applications of Texas Instruments semiconductor products and disclaimers thereto appears at the end of this data sheet.

All trademarks are the property of their respective owners.

PRODUCTION DATA information is current as of publication date. Products conform to specifications per the terms of the Texas Instruments standard warranty. Production processing does not necessarily include testing of all parameters.

Copyright © 2008–2013, Texas Instruments Incorporated

Typical Application

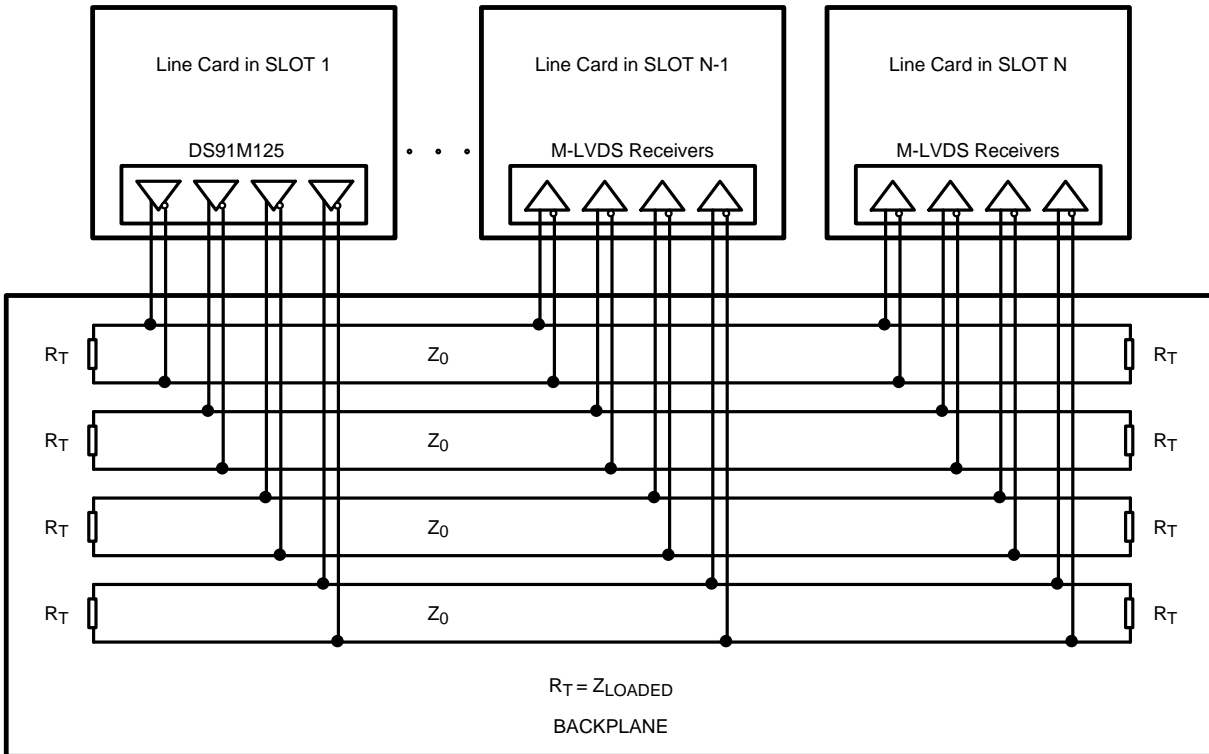

Connection Diagram

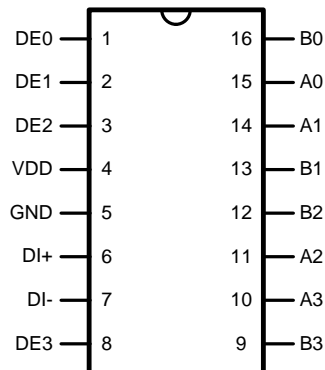
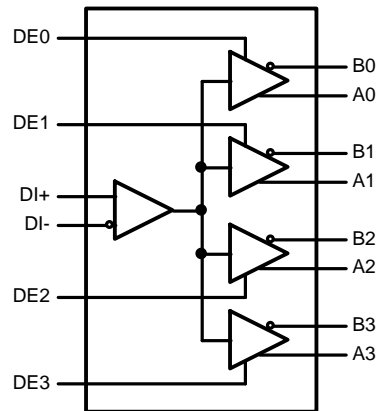

Figure 1. 16-Lead (0.150" Wide) Molded Small Outline Package, JEDEC See Package Number D

Logic Diagram



PIN DESCRIPTIONS

| Number | Name | I/O, Type | Description |
|----------------|-----------------|-----------|--|
| 1, 2, 3, 8 | DE | I, LVCMOS | Driver enable pins: When DE is low, the driver is disabled. When DE is high, the driver is enabled. There is a 300 k Ω pulldown resistor on each pin. |
| 6 | DI+ | I, LVDS | Non-inverting receiver input pin. |
| 7 | DI- | I, LVDS | Inverting receiver input pin. |
| 5 | GND | Power | Ground pin. |
| 10, 11, 14, 15 | A | O, M-LVDS | Non-inverting driver output pin. |
| 9, 12, 13, 16 | B | O, M-LVDS | Inverting driver output pin. |
| 4 | V _{DD} | Power | Power supply pin, +3.3V \pm 0.3V |



These devices have limited built-in ESD protection. The leads should be shorted together or the device placed in conductive foam during storage or handling to prevent electrostatic damage to the MOS gates.

ABSOLUTE MAXIMUM RATINGS⁽¹⁾⁽²⁾

| | | |
|---|---------------------|------------------------------|
| Supply Voltage | | -0.3V to +4V |
| LVCMOS Input Voltages | | -0.3V to ($V_{DD} + 0.3V$) |
| M-LVDS Output Voltages | | -1.9V to +5.5V |
| LVDS Input Voltages | | -0.3V to ($V_{DD} + 0.3V$) |
| Maximum Package Power Dissipation at +25°C | SOIC Package | 2.21W |
| | Derate SOIC Package | 19.2 mW/°C above +25°C |
| Thermal Resistance (4-Layer, 2 oz. Cu, JEDEC) | θ_{JA} | 52°C/W |
| | θ_{JC} | 19°C/W |
| Maximum Junction Temperature | | 140°C |
| Storage Temperature Range | | -65°C to +150°C |
| Lead Temperature (Soldering, 4 seconds) | | 260°C |
| ESD Susceptibility | HBM ⁽³⁾ | ≥ 8 kV |
| | MM ⁽⁴⁾ | ≥ 250V |
| | CDM ⁽⁵⁾ | ≥ 1250V |

- (1) Absolute Maximum Ratings indicate limits beyond which damage to the device may occur, including inoperability and degradation of device reliability and/or performance. Functional operation of the device and/or non-degradation at the Absolute Maximum Ratings or other conditions beyond those indicated in the Recommended Operating Conditions is not implied. The Recommended Operating Conditions indicate conditions at which the device is functional and the device should not be operated beyond such conditions.
- (2) If Military/Aerospace specified devices are required, please contact the TI Sales Office/ Distributors for availability and specifications.
- (3) Human Body Model, applicable std. JESD22-A114C
- (4) Machine Model, applicable std. JESD22-A115-A
- (5) Field Induced Charge Device Model, applicable std. JESD22-C101-C

RECOMMENDED OPERATING CONDITIONS

| | Min | Typ | Max | Units |
|--------------------------------------|------|-----|----------|-------|
| Supply Voltage, V_{DD} | 3.0 | 3.3 | 3.6 | V |
| Voltage at M-LVDS Outputs | -1.4 | | +3.8 | V |
| Voltage at LVDS Inputs | 0 | | V_{DD} | V |
| LVCMOS Input Voltage High V_{IH} | 2.0 | | V_{DD} | V |
| LVCMOS Input Voltage Low V_{IL} | 0 | | 0.8 | V |
| Operating Free Air Temperature T_A | -40 | +25 | +85 | °C |

ELECTRICAL CHARACTERISTICS

 Over recommended operating supply and temperature ranges unless otherwise specified. ⁽¹⁾⁽²⁾⁽³⁾⁽⁴⁾

| Symbol | Parameter | Conditions | Min | Typ | Max | Units |
|--|--|---|---------------------|-----|--------------------|-------|
| LVCMOS DC Specifications | | | | | | |
| V _{IH} | High-Level Input Voltage | | 2.0 | | V _{DD} | V |
| V _{IL} | Low-Level Input Voltage | | GND | | 0.8 | V |
| I _{IH} | High-Level Input Current | V _{IH} = 3.6V | -15 | ±1 | 15 | μA |
| I _{IL} | Low-Level Input Current | V _{IL} = 0V | -15 | ±1 | 15 | μA |
| V _{CL} | Input Clamp Voltage | I _{IN} = -18 mA | -1.5 | | | V |
| M-LVDS Driver DC Specifications | | | | | | |
| V _{AB} | Differential output voltage magnitude | R _L = 50Ω, C _L = 5pF | 480 | | 650 | mV |
| ΔV _{AB} | Change in differential output voltage magnitude between logic states | See Figure 2 and Figure 4 | -50 | 0 | +50 | mV |
| V _{OS(SS)} | Steady-state common-mode output voltage | R _L = 50Ω, C _L = 5pF | 0.3 | 1.6 | 2.1 | V |
| ΔV _{OS(SS)} | Change in steady-state common-mode output voltage between logic states | See Figure 2 and Figure 3 | 0 | | +50 | mV |
| V _{A(OC)} | Maximum steady-state open-circuit output voltage | See Figure 5 | 0 | | 2.4 | V |
| V _{B(OC)} | Maximum steady-state open-circuit output voltage | | 0 | | 2.4 | V |
| V _{P(H)} | Voltage overshoot, low-to-high level output | R _L = 50Ω, C _L = 5pF, C _D = 0.5pF See Figure 7 and Figure 8 ⁽⁵⁾ | | | 1.2V _{SS} | V |
| V _{P(L)} | Voltage overshoot, high-to-low level output | | -0.2V _{SS} | | | V |
| I _{OS} | Differential short-circuit output current | See Figure 6 ⁽⁶⁾ | -43 | | 43 | mA |
| I _A | Driver output current | V _A = 3.8V, V _B = 1.2V | | | 32 | μA |
| | | V _A = 0V or 2.4V, V _B = 1.2V | -20 | | +20 | μA |
| | | V _A = -1.4V, V _B = 1.2V | -32 | | | μA |
| I _B | Driver output current | V _B = 3.8V, V _A = 1.2V | | | 32 | μA |
| | | V _B = 0V or 2.4V, V _A = 1.2V | -20 | | +20 | μA |
| | | V _B = -1.4V, V _A = 1.2V | -32 | | | μA |
| I _{AB} | Driver output differential current (I _A - I _B) | V _A = V _B , -1.4V ≤ V ≤ 3.8V | -4 | | +4 | μA |
| I _{A(OFF)} | Driver output power-off current | V _A = 3.8V, V _B = 1.2V, DE = 0V 0V ≤ V _{DD} ≤ 1.5V | | | 32 | μA |
| | | V _A = 0V or 2.4V, V _B = 1.2V, DE = 0V 0V ≤ V _{DD} ≤ 1.5V | -20 | | +20 | μA |
| | | V _A = -1.4V, V _B = 1.2V, DE = 0V 0V ≤ V _{DD} ≤ 1.5V | -32 | | | μA |

- (1) The Electrical Characteristics tables list ensured specifications under the listed Recommended Operating Conditions except as otherwise modified or specified by the Electrical Characteristics Conditions and/or Notes. Typical specifications are estimations only and are not ensured.
- (2) Current into device pins is defined as positive. Current out of device pins is defined as negative. All voltages are referenced to ground except V_{OD} and ΔV_{OD}.
- (3) Typical values represent most likely parametric norms for V_{DD} = +3.3V and T_A = +25°C, and at the Recommended Operation Conditions at the time of product characterization and are not ensured.
- (4) C_L includes fixture capacitance and C_D includes probe capacitance.
- (5) Specification is ensured by characterization and is not tested in production.
- (6) Output short circuit current (I_{OS}) is specified as magnitude only, minus sign indicates direction only.

ELECTRICAL CHARACTERISTICS (continued)

Over recommended operating supply and temperature ranges unless otherwise specified.⁽¹⁾⁽²⁾⁽³⁾⁽⁴⁾

| Symbol | Parameter | Conditions | Min | Typ | Max | Units |
|--|--|---|------|---------|-----------------|---------|
| $I_{B(OFF)}$ | Driver output power-off current | $V_B = 3.8V, V_A = 1.2V,$ $DE = 0V$ $0V \leq V_{DD} \leq 1.5V$ | | | 32 | μA |
| | | $V_B = 0V$ or $2.4V, V_A = 1.2V,$ $DE = 0V$ $0V \leq V_{DD} \leq 1.5V$ | -20 | | +20 | μA |
| | | $V_B = -1.4V, V_A = 1.2V,$ $DE = 0V$ $0V \leq V_{DD} \leq 1.5V$ | -32 | | | μA |
| $I_{AB(OFF)}$ | Driver output power-off differential current ($I_{A(OFF)} - I_{B(OFF)}$) | $V_A = V_B, -1.4V \leq V \leq 3.8V,$ $DE = 0V$ $0V \leq V_{DD} \leq 1.5V$ | -4 | | +4 | μA |
| C_A | Driver output capacitance | $V_{DD} = OPEN$ | | 7.8 | | pF |
| C_B | Driver output capacitance | | | 7.8 | | pF |
| C_{AB} | Driver output differential capacitance | | | 3 | | pF |
| $C_{A/B}$ | Driver output capacitance balance (C_A/C_B) | | | 1 | | |
| LVDS Receiver DC Specifications | | | | | | |
| V_{IT+} | Positive-going differential input voltage threshold | | | -5 | 100 | mV |
| V_{IT-} | Negative-going differential input voltage threshold | | -100 | -5 | | mV |
| V_{CMR} | Common mode voltage range | $VID = 100 mV$ | 0.05 | | $V_{DD} - 0.05$ | V |
| I_{IN} | Input current | $V_{IN} = 3.6V, V_{DD} = 3.6V$ | | ± 1 | ± 10 | μA |
| | | $V_{IN} = 0V, V_{DD} = 3.6V$ | | ± 1 | ± 10 | μA |
| C_{IN} | Input capacitance | $V_{DD} = OPEN$ | | 5 | | pF |
| POWER SUPPLY CURRENT | | | | | | |
| I_{CCD} | Driver Supply Current | $R_L = 50\Omega, DE = V_{DD}$ | | 67 | 78 | mA |
| I_{CCZ} | TRI-STATE Supply Current | $DE = GND$ | | 21 | 26 | mA |

SWITCHING CHARACTERISTICS

Over recommended operating supply and temperature ranges unless otherwise specified. ⁽¹⁾ ⁽²⁾ ⁽³⁾

| Symbol | Parameter | Conditions | Min | Typ | Max | Units |
|--------------------------------|--|--|-----|-----|-----|-------|
| DRIVER AC SPECIFICATION | | | | | | |
| t_{PLH} | Differential Propagation Delay Low to High | $R_L = 50\Omega$, $C_L = 5\text{ pF}$, | 3.0 | 5.5 | 8.5 | ns |
| t_{PHL} | Differential Propagation Delay High to Low | $C_D = 0.5\text{ pF}$ | 3.0 | 5.5 | 8.5 | ns |
| t_{SKD1} ($t_{sk(p)}$) | Pulse Skew $ t_{PLHD} - t_{PHLD} $ ⁽⁴⁾ ⁽⁵⁾ | See Figure 7 and Figure 8 | | 65 | 350 | ps |
| t_{SKD2} | Channel-to-Channel Skew ⁽⁶⁾ ⁽⁵⁾ | | | 65 | 400 | ps |
| t_{SKD3} | Part-to-Part Skew ⁽⁷⁾ ⁽⁵⁾ | | | 2.2 | 2.5 | ns |
| t_{SKD4} | Part-to-Part Skew ⁽⁸⁾ | | | | 5.5 | ns |
| t_{TLH} (t_r) | Rise Time ⁽⁵⁾ | | 1.1 | 2.0 | 3.0 | ns |
| t_{THL} (t_f) | Fall Time ⁽⁵⁾ | | 1.1 | 2.0 | 3.0 | ns |
| t_{PZH} | Enable Time (Z to Active High) | $R_L = 50\Omega$, $C_L = 5\text{ pF}$, | | 6 | 11 | ns |
| t_{PZL} | Enable Time (Z to Active Low) | $C_D = 0.5\text{ pF}$ | | 6 | 11 | ns |
| t_{PLZ} | Disable Time (Active Low to Z) | See Figure 9 and Figure 10 | | 6 | 11 | ns |
| t_{PHZ} | Disable Time (Active High to Z) | | | 6 | 11 | ns |
| f_{MAX} | Maximum Operating Frequency ⁽⁵⁾ | | 125 | | | MHz |

- (1) The [ELECTRICAL CHARACTERISTICS](#) tables list ensured specifications under the listed Recommended Operating Conditions except as otherwise modified or specified by the Electrical Characteristics Conditions and/or Notes.
- (2) Typical values represent most likely parametric norms for $V_{DD} = +3.3V$ and $T_A = +25^\circ C$, and at the Recommended Operation Conditions at the time of product characterization and are not ensured.
- (3) C_L includes fixture capacitance and C_D includes probe capacitance.
- (4) t_{SKD1} , $|t_{PLHD} - t_{PHLD}|$, is the magnitude difference in differential propagation delay time between the positive going edge and the negative going edge of the same channel.
- (5) Specification is ensured by characterization and is not tested in production.
- (6) t_{SKD2} , Channel-to-Channel Skew, is the difference in propagation delay (t_{PLHD} or t_{PHLD}) among all output channels.
- (7) t_{SKD3} , Part-to-Part Skew, is defined as the difference between the minimum and maximum specified differential propagation delays. This specification applies to devices at the same V_{DD} and within $5^\circ C$ of each other within the operating temperature range.
- (8) t_{SKD4} , Part-to-Part Skew, is the differential channel-to-channel skew of any event between devices. This specification applies to devices over recommended operating temperature and voltage ranges, and across process distribution. t_{SKD4} is defined as $|Max - Min|$ differential propagation delay.

TEST CIRCUITS AND WAVEFORMS

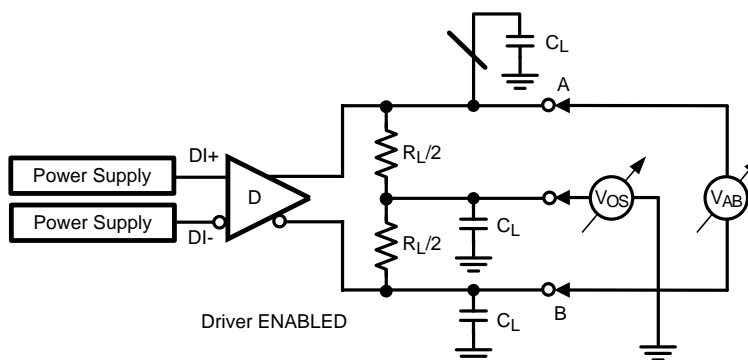

Figure 2. Differential Driver Test Circuit

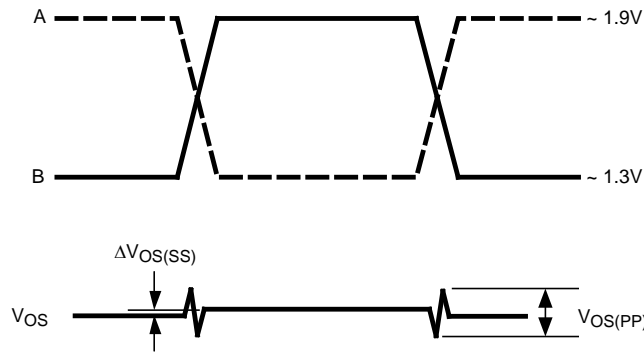

Figure 3. Differential Driver Waveforms

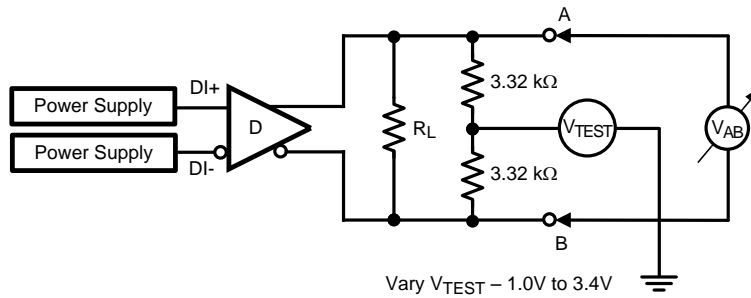

Figure 4. Differential Driver Full Load Test Circuit

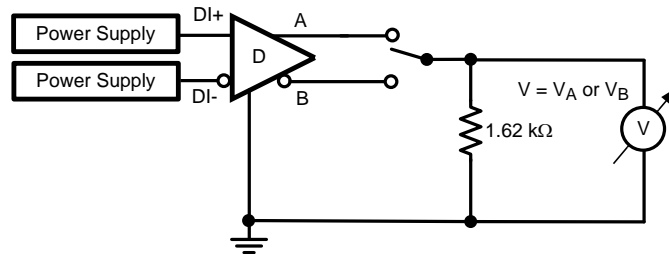

Figure 5. Differential Driver DC Open Test Circuit

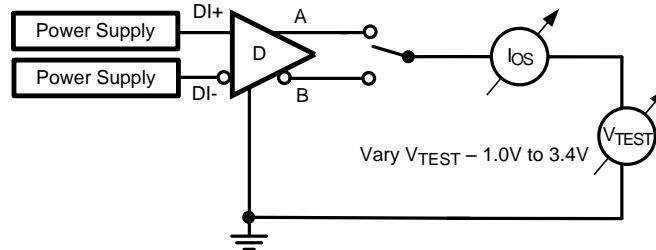

Figure 6. Differential Driver Short-Circuit Test Circuit

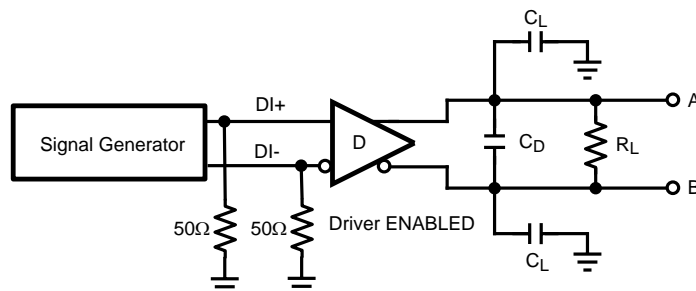

Figure 7. Driver Propagation Delay and Transition Time Test Circuit

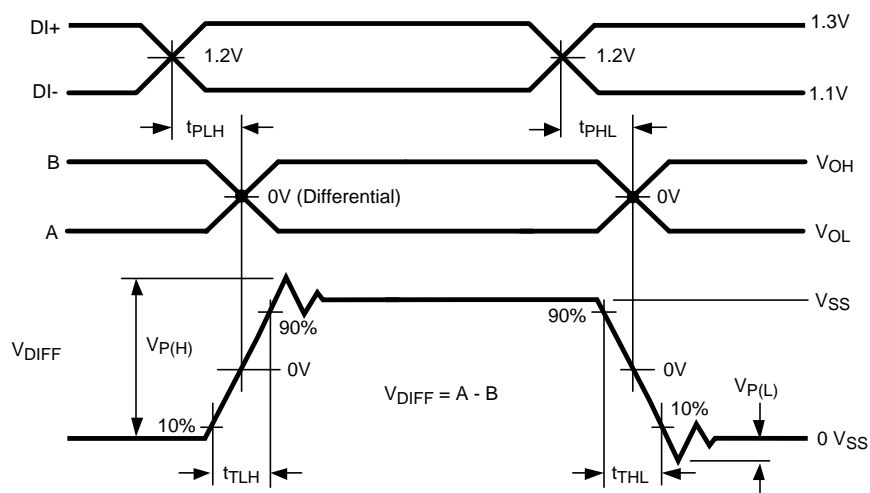

Figure 8. Driver Propagation Delays and Transition Time Waveforms

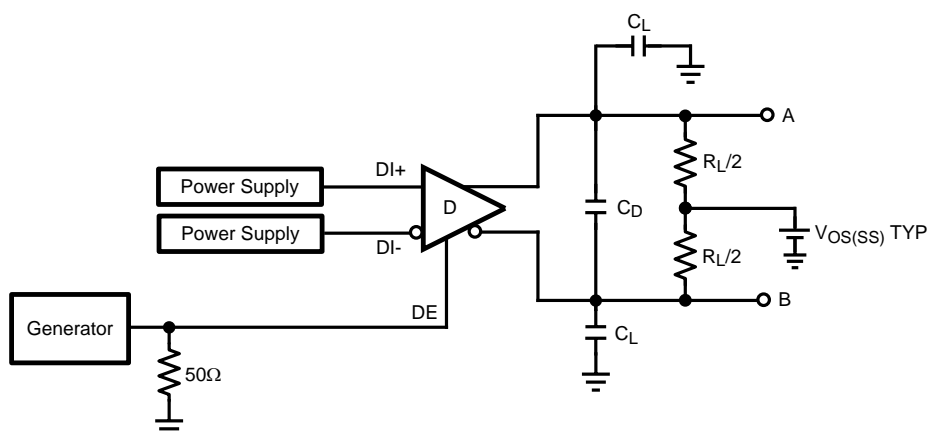

Figure 9. Driver TRI-STATE Delay Test Circuit

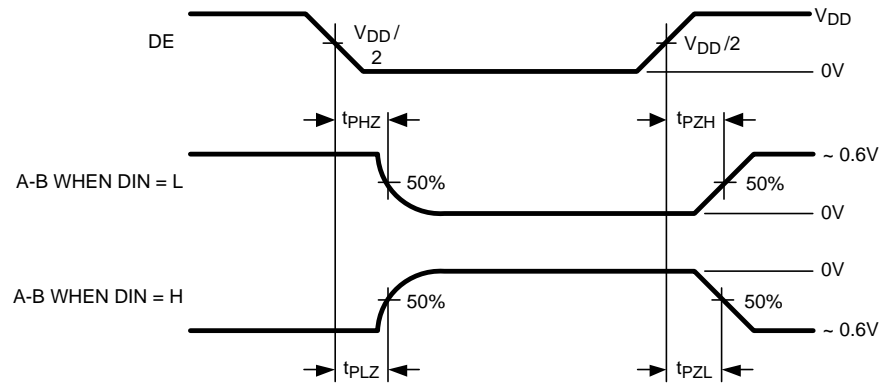

Figure 10. Driver TRI-STATE Delay Waveforms

TYPICAL PERFORMANCE CHARACTERISTICS

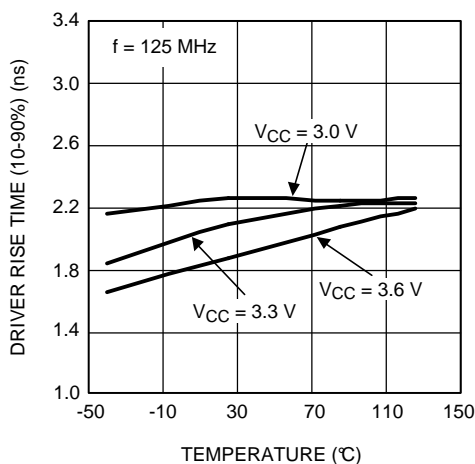

Figure 11. Driver Rise Time as a Function of Temperature

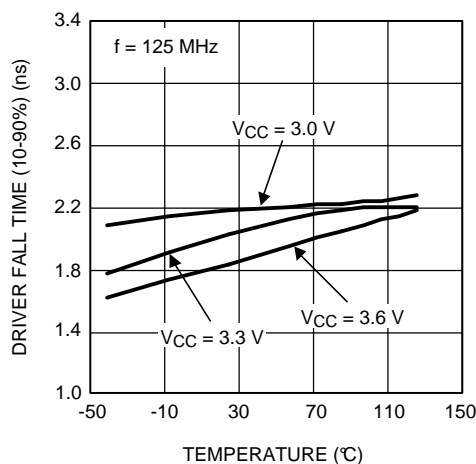

Figure 12. Driver Fall Time as a Function of Temperature

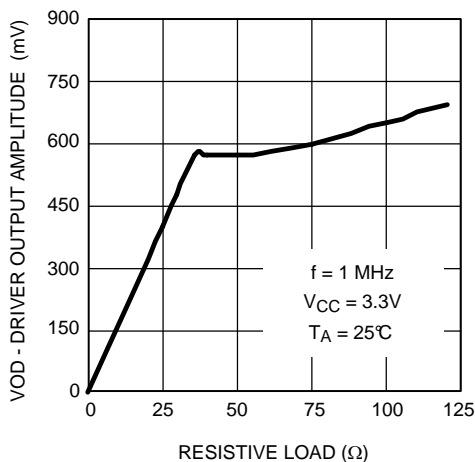

Figure 13. Driver Output Signal Amplitude as a Function of Resistive Load

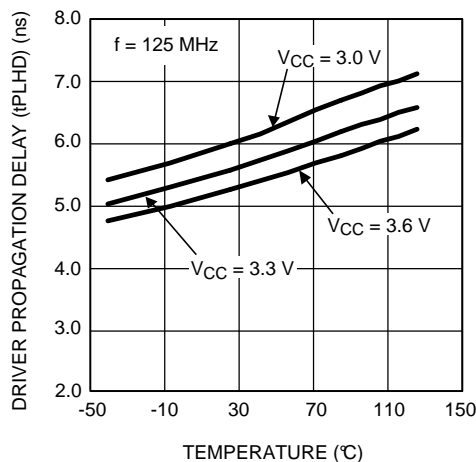

Figure 14. Driver Propagation Delay (tPLHD) as a Function of Temperature

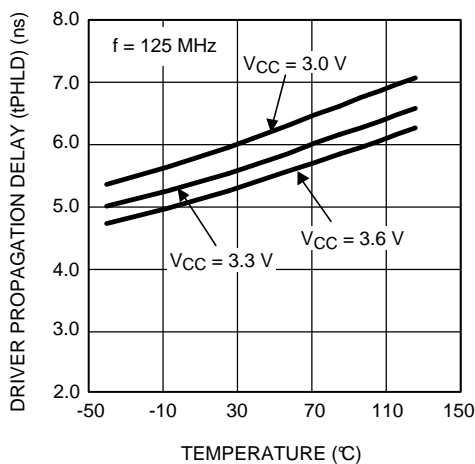

Figure 15. Driver Propagation Delay (tPHLD) as a Function of Temperature

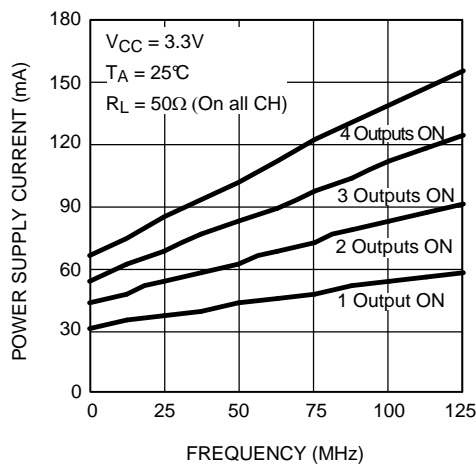



Figure 16. Driver Power Supply Current as a Function of Frequency

REVISION HISTORY

| Changes from Revision B (April 2013) to Revision C | Page |
|--|--------------------|
| • Changed layout of National Data Sheet to TI format | 11 |

PACKAGING INFORMATION

| Orderable Device | Status (1) | Package Type | Package Drawing | Pins | Package Qty | Eco Plan (2) | Lead finish/ Ball material (6) | MSL Peak Temp (3) | Op Temp (°C) | Device Marking (4/5) | Samples |
|-------------------|---------------|--------------|-----------------|------|-------------|-----------------|--------------------------------------|----------------------|--------------|-------------------------|---|
| DS91M125TMA/NOPB | ACTIVE | SOIC | D | 16 | 48 | RoHS & Green | SN | Level-1-260C-UNLIM | -40 to 85 | DS91M125 TMA |  |
| DS91M125TMAX/NOPB | ACTIVE | SOIC | D | 16 | 2500 | RoHS & Green | SN | Level-1-260C-UNLIM | -40 to 85 | DS91M125 TMA |  |

(1) The marketing status values are defined as follows:

ACTIVE: Product device recommended for new designs.

LIFEBUY: TI has announced that the device will be discontinued, and a lifetime-buy period is in effect.

NRND: Not recommended for new designs. Device is in production to support existing customers, but TI does not recommend using this part in a new design.

PREVIEW: Device has been announced but is not in production. Samples may or may not be available.

OBSOLETE: TI has discontinued the production of the device.

(2) **RoHS:** TI defines "RoHS" to mean semiconductor products that are compliant with the current EU RoHS requirements for all 10 RoHS substances, including the requirement that RoHS substance do not exceed 0.1% by weight in homogeneous materials. Where designed to be soldered at high temperatures, "RoHS" products are suitable for use in specified lead-free processes. TI may reference these types of products as "Pb-Free".

RoHS Exempt: TI defines "RoHS Exempt" to mean products that contain lead but are compliant with EU RoHS pursuant to a specific EU RoHS exemption.

Green: TI defines "Green" to mean the content of Chlorine (Cl) and Bromine (Br) based flame retardants meet JS709B low halogen requirements of <=1000ppm threshold. Antimony trioxide based flame retardants must also meet the <=1000ppm threshold requirement.

(3) MSL, Peak Temp. - The Moisture Sensitivity Level rating according to the JEDEC industry standard classifications, and peak solder temperature.

(4) There may be additional marking, which relates to the logo, the lot trace code information, or the environmental category on the device.

(5) Multiple Device Markings will be inside parentheses. Only one Device Marking contained in parentheses and separated by a "~" will appear on a device. If a line is indented then it is a continuation of the previous line and the two combined represent the entire Device Marking for that device.

(6) Lead finish/Ball material - Orderable Devices may have multiple material finish options. Finish options are separated by a vertical ruled line. Lead finish/Ball material values may wrap to two lines if the finish value exceeds the maximum column width.

Important Information and Disclaimer:The information provided on this page represents TI's knowledge and belief as of the date that it is provided. TI bases its knowledge and belief on information provided by third parties, and makes no representation or warranty as to the accuracy of such information. Efforts are underway to better integrate information from third parties. TI has taken and continues to take reasonable steps to provide representative and accurate information but may not have conducted destructive testing or chemical analysis on incoming materials and chemicals. TI and TI suppliers consider certain information to be proprietary, and thus CAS numbers and other limited information may not be available for release.

In no event shall TI's liability arising out of such information exceed the total purchase price of the TI part(s) at issue in this document sold by TI to Customer on an annual basis.

TAPE AND REEL INFORMATION

QUADRANT ASSIGNMENTS FOR PIN 1 ORIENTATION IN TAPE

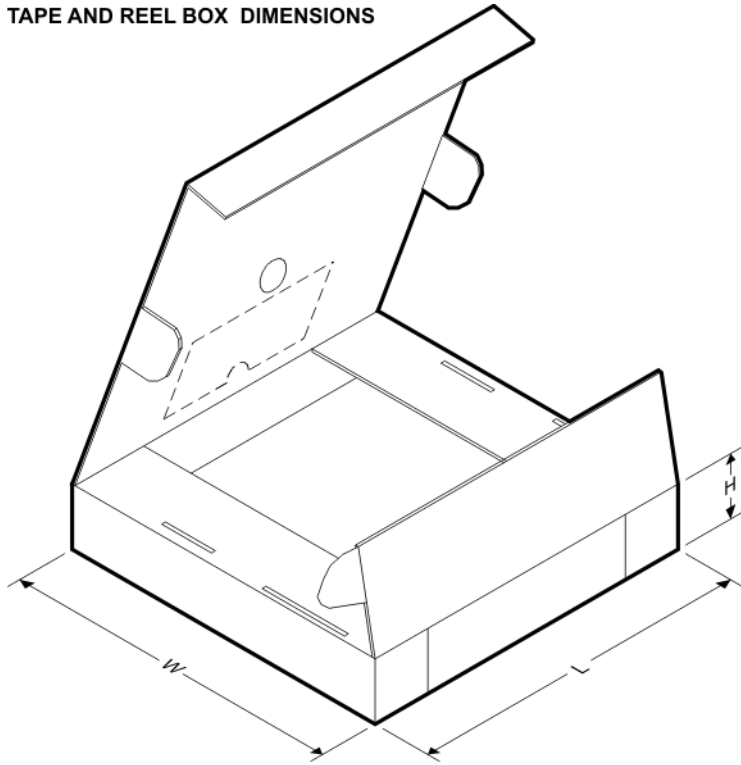

*All dimensions are nominal

| Device | Package Type | Package Drawing | Pins | SPQ | Reel Diameter (mm) | Reel Width W1 (mm) | A0 (mm) | B0 (mm) | K0 (mm) | P1 (mm) | W (mm) | Pin1 Quadrant |
|-------------------|--------------|-----------------|------|------|--------------------|--------------------|---------|---------|---------|---------|--------|---------------|
| DS91M125TMAX/NOPB | SOIC | D | 16 | 2500 | 330.0 | 16.4 | 6.5 | 10.3 | 2.3 | 8.0 | 16.0 | Q1 |

TAPE AND REEL BOX DIMENSIONS

*All dimensions are nominal

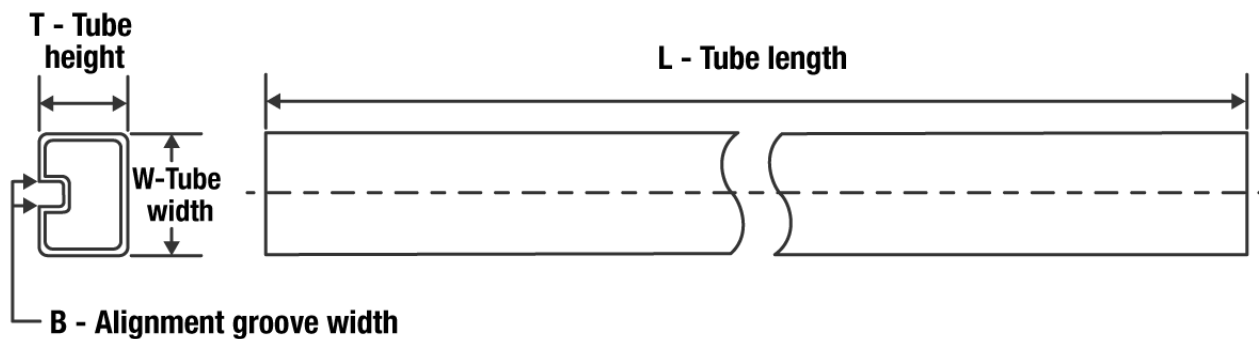
| Device | Package Type | Package Drawing | Pins | SPQ | Length (mm) | Width (mm) | Height (mm) |
|-------------------|--------------|-----------------|------|------|-------------|------------|-------------|
| DS91M125TMAX/NOPB | SOIC | D | 16 | 2500 | 367.0 | 367.0 | 35.0 |

TUBE

*All dimensions are nominal

| Device | Package Name | Package Type | Pins | SPQ | L (mm) | W (mm) | T (μm) | B (mm) |
|------------------|--------------|--------------|------|-----|--------|--------|--------|--------|
| DS91M125TMA/NOPB | D | SOIC | 16 | 48 | 495 | 8 | 4064 | 3.05 |

D (R-PDSO-G16)

PLASTIC SMALL OUTLINE



4040047-6/M 06/11

- NOTES:
- A. All linear dimensions are in inches (millimeters).
 - B. This drawing is subject to change without notice.
 -  Body length does not include mold flash, protrusions, or gate burrs. Mold flash, protrusions, or gate burrs shall not exceed 0.006 (0,15) each side.
 -  Body width does not include interlead flash. Interlead flash shall not exceed 0.017 (0,43) each side.
 - E. Reference JEDEC MS-012 variation AC.

IMPORTANT NOTICE AND DISCLAIMER

TI PROVIDES TECHNICAL AND RELIABILITY DATA (INCLUDING DATA SHEETS), DESIGN RESOURCES (INCLUDING REFERENCE DESIGNS), APPLICATION OR OTHER DESIGN ADVICE, WEB TOOLS, SAFETY INFORMATION, AND OTHER RESOURCES "AS IS" AND WITH ALL FAULTS, AND DISCLAIMS ALL WARRANTIES, EXPRESS AND IMPLIED, INCLUDING WITHOUT LIMITATION ANY IMPLIED WARRANTIES OF MERCHANTABILITY, FITNESS FOR A PARTICULAR PURPOSE OR NON-INFRINGEMENT OF THIRD PARTY INTELLECTUAL PROPERTY RIGHTS.

These resources are intended for skilled developers designing with TI products. You are solely responsible for (1) selecting the appropriate TI products for your application, (2) designing, validating and testing your application, and (3) ensuring your application meets applicable standards, and any other safety, security, regulatory or other requirements.

These resources are subject to change without notice. TI grants you permission to use these resources only for development of an application that uses the TI products described in the resource. Other reproduction and display of these resources is prohibited. No license is granted to any other TI intellectual property right or to any third party intellectual property right. TI disclaims responsibility for, and you will fully indemnify TI and its representatives against, any claims, damages, costs, losses, and liabilities arising out of your use of these resources.



TI's products are provided subject to [TI's Terms of Sale](#) or other applicable terms available either on ti.com or provided in conjunction with such TI products. TI's provision of these resources does not expand or otherwise alter TI's applicable warranties or warranty disclaimers for TI products.

TI objects to and rejects any additional or different terms you may have proposed.

Mailing Address: Texas Instruments, Post Office Box 655303, Dallas, Texas 75265
Copyright © 2022, Texas Instruments Incorporated

Looking for pricing, stock, or lifecycle information?

Click below to explore more details on WIN SOURCE:

-  [View FN9222R-20-06 on WIN SOURCE](#)
-  [Schaffner EMC Inc. Information](#)

Optimize Your Supply Chain with WIN SOURCE Solutions

-  Global Sourcing Solution
-  Obsolete Management
-  Cost Control Management
-  Shortage Management
-  Alternative Solution
-  Excess Inventory Management